

TOMASZ HUŚCIO, ROMAN TROCHIMCZUK*

ROPE-FREE MULTI-CABIN ELEVATOR SYSTEM FOR VERTICAL AND HORIZONTAL TRANSPORT AND SIMULTANEOUS INTEGRATION OF MOVEMENT IN TWO DIRECTIONS

SYSTEM WIELOKABINOWEJ BEZLINOWEJ WINDY DO TRANSPORTU PIONOWEGO I POZIOMEGO ORAZ W DWÓCH KIERUNKACH JEDNOCZEŚNIE

Abstract

This article presents a novel rope-free multi-cabin elevator system for vertical and horizontal transport and simultaneous integration of movement in two directions. Using the patent applications to the Patent Office of the Republic of Poland, the structure and the principle of operation of the rope-free elevator is presented. The advantages of using the mechatronic rope-free multi-cabin elevator in novel, multi-area high rise buildings are presented. The directions of further studies are outlined.

Keywords: elevator; rope-free elevator; vertical and horizontal elevator; multi-cabin elevator

Streszczenie

W artykule przedstawiono nowatorskie rozwiązanie systemu wielokabinowej bezlinowej windy do transportu pionowego i poziomego oraz w dwóch kierunkach jednocześnie. W oparciu o dokonane autorskie zgłoszenia patentowe do Urzędu Patentowego Rzeczypospolitej Polskiej opisano budowę i zasadę działania bezlinowej windy. Wskazano zalety zastosowania proponowanego rozwiązania w nowoczesnych, wielkopowierzchniowych, wielokondygnacyjnych budynkach. W podsumowaniu wskazano kierunki dalszych badań nad prototypowym rozwiązaniem.

Słowa kluczowe: winda, bezlinowa winda, winda do transportu pionowego i poziomego, system windy wielokabinowej

* Ph.D. Eng. Tomasz Huścio, Ph.D. Eng. Roman Trochimczuk, Department of Automatic Control and Robotics, Faculty of Mechanical Engineering, Białystok University of Technology.

1. Introduction

In large urban agglomerations, due to limited areas of construction lots, developers are investing into the construction of very tall, multi-storey buildings intended as residential, office, or commercial buildings. Solutions of this type pose a very big engineering and logistical challenge. The materials and techniques of raising such buildings require the application of technologically advanced methods and construction techniques as well as modern, strong, and light materials from designing teams. Modern skyscraper designs account for factors, such as: increased action of atmospheric factors (e.g. wind, rain, snow, variable temperature dependent on height), disrupted equilibrium of the building due to tectonic movements, or even a potential terrorist attack, which is being taken very seriously after the events at the World Trade Center in 2001.

The only element of skyscraper design and construction that has remained practically unchanged since its inception is the elevator. Of course, modern elevators differ in terms of appearance, applied structural materials, drives, equipment, speed, and noise level during movement compared to the first designs invented and used in the 19th century. However, the principle of their operation remains essentially unchanged. This principle is the movement of cabins between storeys of buildings on the vertical plane (in a shaft) with the application of load-bearing tension members (lines, chains) [1, 2].

To increase transportation capabilities in high-rises, complexes of multiple shafts are usually built, in which even several cabins may move simultaneously in more recent solutions. In the case of very tall, multi-storey, large-area buildings, the systems available on the market may prove insufficient. In particular, this may pertain to the situation of elevator operation during hours of increased operation (morning or afternoon load arising from the beginning or end of the workday, holiday, etc.) or emergency situations (e.g. fire on a given storey of a building).

In relation to the above, it seems purposeful to develop modern elevator designs that simultaneously serve for vertical and horizontal transport, with cabins, and whose movement within the building is not limited by the design of individual shafts.

This article presents an innovative solution of an elevator for transportation of persons and objects in the vertical and horizontal direction as well as in both directions simultaneously, with the capability of moving cabins over a track of arbitrary shape. Depending on the actual needs, surface area, and number of storeys of the building, as well as the number of rooms to which cabins may travel, an elevator can have a single cabin or multiple cabins.

2. Selected modern elevator solution

The main engineering problem facing designers of modern tower blocks is the distribution and number of communication routes, transportation channels, and potential evacuation routes. Arrival at a given storey of a building must be as fast as possible. Currently applied elevator solutions with an engine room and traditional vertical shaft are becoming increasingly inefficient and insufficient, particularly with regard to high-rises.

By analyzing selected works in the scope of de-signing new multi-cabin solutions for elevator systems [3–10], the primary sources of problems that may appear during elevator operation can be defined. Such problems include, among others: types and lengths of ropes used, vibrations during movement, the problem of cabin rocking during movement at high speeds, the types of drives used in the design, as well as very important issues related to safety of elevator use. These problems can be eliminated by applying rope-free elevator systems.

In most studies, the authors mainly focus on researching new algorithms for controlling elevator systems currently applied in multi-storey buildings. However, in the presented innovative solutions, direct drive linear motors are used as the drive source. Published results of studies confirm the hypothesis that drives of this type may contribute to solving problems arising from application of a rope as the tension member drawing the elevator cabin. However, cabin movement remains restricted by the shaft walls, and it can only be horizontal or vertical.

Information concerning an innovative elevator design by the ThyssenKrupp company from Germany appeared in the media at the end of 2014. Its trade name is MULTI [11, 12]. In the proposed solution, the cabin moves on both the horizontal and the vertical plane. The solution is based on linear motors and utilizes the phenomenon of magnetic levitation. According to reports, the proposed solution may revolutionize the elevator system used until now. The same company also developed an innovative solution based on placing two cabins in a single shaft [13], which is intended to increase transportation capabilities.

Neither of these solutions provides a single cabin with the capability of simultaneous movement in two directions. Moreover, it is not possible to arbitrarily shape the form of the shaft in which cabins travel. This may be of great importance when designing multi-storey buildings with imaginative shapes.

3. Design and principle of operation of the original rope-free elevator

Fig. 1 presents the general concept of the rope-free elevator with cabins moving vertically, horizontally and in two directions at once. The elevator consists of cabins (1) moving over the wall of a shaft (2) situated inside of a building (3). Cabins (1) may be: single-door – with one entrance; double-door – with two opposite entrances; angular – with two entrances at an angle of 90° relative to one another; three-sided – with three entrances on neighboring walls; four-sided – with four entrances – one on each wall. Cabins may move in a closed or partially open shaft.

The elevator's drive utilizes a planar positioning system with Hall sensors. A detailed description of the design and principle of operation of planar positioners can be found in works [14–22], among others.

Fig. 2 presents components of the rope-free elevator for transport in the vertical and horizontal direction as well as in both directions simultaneously in the example configuration with one cabin and two opposite entrances.

The main components of the cabin's planar positioning system are immobile planar stators (4) installed on the shaft surface (2) and mobile planar forcings (6) installed on the

exterior side surfaces of the cabin (1). Electromagnetic drive modules installed on the bearing surfaces of planar forcers (6) are responsible for moving the cabin (1) over the track comprising planar stators (4) and for attraction of the cabin (1) to the stators (4). Planar stators (4) serving for movement of the cabin (1) can form a track of any shape or can be distributed over the entire surface of the shaft's (2) walls. This solution allows for movement of the cabin (1) in the horizontal and vertical direction as well as in both directions at the same time, enabling travel to any door (7) of a room or door leading to a corridor.

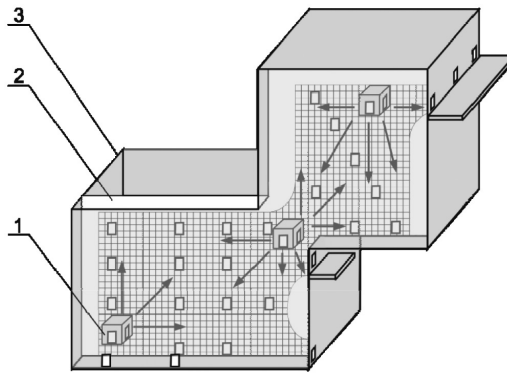

Fig. 1. Rope-free multi-cabin elevator system for vertical and horizontal transport and simultaneous integration of movement in two directions [23]

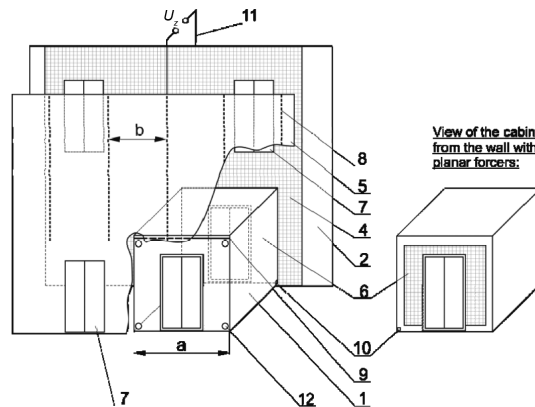

Fig. 2. The main elements of rope-free elevator system [23]

The cabin (1) moves over the shaft (2) without coming into contact with it thanks to the application of aerostatic bearings. A layer of air with pressure greater than atmospheric pressure is generated between forcers (6) and stators (4), forming an air cushion that balances the forces of electromagnetic attraction of forcers (6) to stators (4), among others. The above necessitates equipping every cabin with its own source of compressed air, which is indispensable for generating the air cushion between the planar stators (4) and the planar forcers (6). A compressor with a pressure vessel or a pressure vessel by itself can be installed

on the elevator cabin. Another option is to install a station generating compressed air in the shaft, to which the cabin (1) would have to travel and connect to (dock) in order to replenish air in the pressure vessel.

In order to ensure a constant height of the air gap over the entire area of stator/forcer inter-operation, a system of supporting elements (12) made up of kinematic pairs with three degrees of freedom, all rotating.

Electrical supply to the cabin (1) is carried out by means of a contact system (Fig. 2). A contact system (8) for power supply is distributed on the wall (5). Electricity flows from power supply cables (8) through the current collector (9) to the cabin's (1) electrical system powering individual forcers (6), the compressor, which is required for generating the air cushion, and the control system along with the operator's panel and cabin lighting. From receivers in the cabin (1), electrical current flows through the return current collector (10), stators (4) and the cables connected to them (11). Electrical power supply to the cabin necessitates the distribution of individual power supply cables (8) at a distance b less than distance a of the current collector (9) placed on the cabin's wall (1). This solution ensures uninterrupted contact of current collectors (9) with the network of power supply cables (8) during movement of the cabin (1) over a track of any shape made up of stators (4).

4. Advantages of application of the innovative solution

The rope-free elevator can be applied in multi-storey buildings in which the distribution and number of rooms to which the cabin is to travel necessitates the application of an arbitrary shape of transportation routes in the shaft. The proposed system has indisputable advantages that may bring new quality to intra-building transport of persons and objects. Among them, the following deserve special attention [23–25]:

- the elevator is rope-free – there is no need to install a machine room or lines on which cabins would be suspended in shafts,
- transport can take place vertically and horizontally as well as in two directions of movement simultaneously,
- a track of any shape can be formed over the entire surface of the shaft's walls for movement of cabins in the vertical and horizontal directions as well as in both directions at once,
- the ability to arbitrarily shape the track on the surface of the shaft allows for the application of the proposed solution in buildings with imaginative shapes,
- the application of aerostatic bearings in the drive system eliminates wear between inter-operating surfaces of stators and forcers; there is no need for periodical lubrication of guides, which translates to limitation of activities related to maintenance of the transportation system and reduction of operating costs,
- in the case of an emergency situation related to e.g. loss of electrical power or pneumatic supply required for generation of the air cushion, because electromagnetic drive modules contain strong rare earth magnets, the cabin will not fall, but rather be drawn to the shaft wall, where it will remain safely until the problem is solved by technical teams or the emergency power supply system is activated,

- the multi-cabin system enables optimal configuration of the number of cabins moving in the shaft over a track of arbitrary shape, which allows for rapid and flexible reaction to actual transportation needs within a given large-area building,
- capability of achieving greater cabin movement speeds compared to typical solutions due to the lack of the air cushion effect, resulting in resistance during vertical movement of a cabin in a standard shaft.

5. Summary

The original solution of a rope-free elevator with cabins moving vertically, horizontally and in two directions at once was presented in this article. Single- or multi-cabin passenger, freight, passenger and freight, car, etc. elevators can be installed in newly built or existing buildings based on the proposed solution.

The drive of the rope-free elevator, made on the basis of planar positioner units with Hall sensors, allows for designing of an elevator with a shaft of any shape as well as a multi-walled shaft enabling movement of cabins from one wall to a neighboring wall of the shaft. In the basic configuration, such a shaft can consist of two walls sharing an edge, positioned at a right angle relative to one another. Based on this solution, elevator shafts consisting of multiple walls over which cabins can travel can be built.

Within the framework of further work on the design of the rope-free elevator, expansion of the research laboratory station to an extent enabling testing of the programs responsible for collision-free control of the system, studying the behavior of cabins under varying loads in dynamic conditions, and assessment of vibration damping by the air cushion separating stators from inductors, is planned. The results will be used to elaborate the rope-free multi-cabin elevator system and for quick and flexible reaction to actual transport needs within a given large-area building, as well as for fast and safe arrival of passengers to individual rooms of the building. The development algorithms will be implemented in the laboratory station and used in the mechatronic rope-free multi-car elevator system after being verified.

This research has been done as a part of a statutory research of Department of Automatic Control and Robotics, Faculty of Mechanical Engineering which is funded by Białystok's University of Technology, Poland.

References

- [1] McCain Z., *Elevators 101*, Elevator World, 2004.
- [2] Strakosch G.R. (Editor), *The Vertical Transportation Handbook*, Wiley Online Library, 2007.
- [3] Ishii T., *Elevators for skyscrapers*, IEEE Spectrum, 31 (9), September 1994, 42–46.
- [4] Hong Sun Lim, Krishnan R., *Ropeless elevator with linear switched reluctance motor drive actuation systems*, IEEE Transactions on Industrial Electronics – IEEE Trans Ind Electron, vol. 54, no. 4, 2007, 2209–2218.

- [5] Sakamoto T., Noma Y., *Guidelines for VSS Controller Design of LSM-Driven Ropeless Elevator*, IEEE International Symposium on Industrial Electronics, Seoul, 5–8 July 2009, 1564–1568.
- [6] Schmulling B., Effing O., Hameyer K., *State Control of an Electromagnetic Guiding System for Ropeless Elevators*, European Conference on Power Electronics and Applications, Aalborg, 2–5 September 2007, 1–10.
- [7] Toida K., Honda T., Hounng-Joong K., Watada M., Torii S., Ebihara D., *The positioning control with velocity feed-forward for the rope-less elevator using linear synchronous motor*, Conference: Electric Machines and Drives IEEE International Conference – IEMDC, 1997.
- [8] Yamaguchi H., Osawa H., Watanabe T., Yamada H., *Brake control characteristics of a linear synchronous motor for ropeless elevator*, Advanced Motion Control, 1996. AMC '96-MIE. Proceedings, 1996 4th International Workshop on, Vol. 2, 1996, 441–446.
- [9] <http://www.elevatorworld.com> (access: 20.12.2015).
- [10] Liu J., Wu Y., Dai J., Liu M., Wu Ch., Gao E., *Overstep Control Analysis for Multi-car Elevator*, Proceedings of 2012 International Conference on Modelling, Identification and Control, ICMIC, IEEE, Wuhan, Hubei, China 2012, 24–26 June, 254–259.
- [11] www.designboom.com/technology/worlds-first-rope-free-elevator-multi-12-05-2014 (access: 20.12.2015).
- [12] www.dezeen.com/2014/12/01/thyssenkrupp-multi-elevator-uses-magnets-to-move-vertically-and-horizontally (access: 20.12.2015).
- [13] ThyssenKrupp Elevator 2015, *Two elevator cabs have always meant two shafts. Until now. TWIN – A singular revolution in elevator design*, www.thyssenkruppelevator.com/downloads/TWIN.pdf. (access: 20.12.2015).
- [14] Huścio T., *Modelowanie płaskich podpór pneumatycznych z napędem elektromagnetycznych*, Doctoral thesis, Politechnika Białostocka, Białystok 2009.
- [15] Trochimeczuk R., *Mechatroniczne pozycjonowanie wiązki lasera impulsowego w urządzeniach do formowania obiektów trójwymiarowych w szkle*, Doctoral thesis, Kraków, Akademia Górniczo-Hutnicza, 2009.
- [16] Kuźmierowski T., Trochimeczuk R., *Application of planar positioning system in selected mechatronic structure*, International Journal of Applied Mechanics and Engineering, Vol. 17, No. 4, 2012, 1377–1384.
- [17] Kallenbach E., Kireev V., Volkert R., Zentner J., Bertram T., *Configuration and Control Aspects of High-Precision Planar Multi-Coordinate Drive Systems*, ASPE 19th Annual Meeting, Orlando, Florida 2004, 185–188.
- [18] Huścio T., Trochimeczuk R., *Mechatroniczne urządzenie rehabilitacyjne zbudowane na bazie pozycjonera planarnego*, Mechanik Nr 10/2015, DOI: 10.17814/mechanik.2015.10.519, 808–811.
- [19] Quaid A.E., Hollis R.L., *Cooperative 2-DOF Robots for Precision Assembly*, International Conference on Robotics and Automation, Minneapolis, April 22–28, 1996.
- [20] Lauwers T.B., Edmondson Z.K., Hollis R.L., *Progress in agile assembly: minifactory couriers based on free-roaming planar motors*, 4th Int'l. Workshop on Microfactories, Oct. 15–17, Shanghai, P. R. China 2004, 7–10.

- [21] Hollis R.L., Gowdy J., *Miniature Factories for Precision Assembly*, Proc Int'l Workshop on Micro-Factories, December 7–8, Japan, Tsukuba 1998.
- [22] Hollis R.L., Gowdy J., Rizzi A.A., *Design and Development of a Tabletop Precision Assembly System*, Mechatronics and Robotics, (MechRob'04), September 13–15, Germany, Aachen 2004, 1619–1623.
- [23] Huścio T., Trochimczuk R., *Mechatroniczna bezlinowa winda do transportu pionowego i poziomego z możliwością przemieszczania kabin w zamkniętym lub w częściowo otwartym szybie*, Patent Application nr P.415251, Patent Office of the Republic of Poland.
- [24] Trochimczuk R., Huścio T., *System przemieszczania kabiny do mechatronicznej bezlinowej windy do transportu pionowego i poziomego oraz w dwóch kierunkach jednocześnie w zamkniętym lub w częściowo otwartym szybie*, Patent Application nr P.415270, Patent Office of the Republic of Poland.
- [25] Huścio T., Trochimczuk R., *System przemieszczania kabiny do mechatronicznej bezlinowej windy do transportu pionowego i poziomego oraz w dwóch kierunkach jednocześnie w zamkniętym lub w częściowo otwartym szybie*, Patent Application nr P.415269, Patent Office of the Republic of Poland.