

MAXIMILIAN FECHTER, MATTHIAS KRAUME\*

## DIGESTATE TREATMENT TECHNIQUES

---

### PRZETWARZANIE POZOSTAŁOŚCI POFERMENTACYJNYCH

#### Abstract

Even though digestate is rich in plant nutrients, its value as a fertiliser is low due to its high water content of 90 to 95%. Therefore, the main objective of digestate treatment is to extract clean water in order to concentrate the plant nutrients. These are either in solution or attached to organic particles. Roughly, more than 70% of the digestate's solid particles are smaller than 1 mm and are not easily separated, because of particle size, charge and density. This is one of the reasons why a simple screen separation provides no solution to the problem; however, it is an important step in the treatment chain. During the research project, many different digestate treatment techniques were considered – all of these are recorded in Figure 10.

This article provides an overview of the possible techniques for digestate treatment, how they work, and their central research parameters.

*Keywords: digestate, proces engineering*

#### Streszczenie

Pozostałości pofermentacyjne są bogate w roślinne składniki pokarmowe roślin, jednak ich wartość jako nawóz jest niska z powodu dużej zawartości wody od 90 do 95%. Głównym celem przetwarzania pozostałości jest oddzielenie czystej wody w celu koncentracji składników pokarmowych, które znajdują się w postaci roztworu lub są dołączone do cząstek organicznych, co sprawia, że separacja na pojedynczej membranie jest niewystarczająca. W pracy przedstawiono różne techniki przetwarzania pozostałości pofermentacyjnych.

*Słowa kluczowe: pozostałości pofermentacyjne, inżynieria procesowa*

#### DOI:

---

\* MSc. Eng. Maximilian Fechter, Prof. PhD. DSc. Eng. Matthias Kraume, Chair of Chemical & Process Engineering, Faculty of Process Sciences, Technical University of Berlin.

## 1. Introduction

Digestate treatment has become a major challenge since the latest amendment of the EEG in Germany. The EEG from 2014 states a minimum storage capacity for digestate of 150 days and applies to all fermenters built after 2012 [5]. *The Federal Ministry for the Environment, Nature Conservation, Building and Nuclear Safety* plans to increase the storage time to nine months for biogas plants that cannot apply the digestate on their own fields [7]. Those biogas plants are in urgent need of either digestate treatment or a costly digestate storage tank. The advantages of digestate treatment as opposed to the use of a storage tank are the reduced space requirement, lower transportation costs, and lower fuel and time requirements when applying the digestate onto land due to the reduction in volume. However, even though di-gestate treatment offers many advantages, it also causes many problems. Digestate from a regular mesophilic bio fermenter that is fed with energy-crops and manure, consists of over 90% water. The remainder is biomass, which is rich in plant nutrients and is usually no longer digestible for the majority of bacteria. Around 50% of its particles are smaller than one millimetre and perfectly suspended in the water due to their negatively charged surface. This makes it difficult to separate them. The digestate’s high chemical oxygen demand (COD), which takes values between 50 and 120 kg/t [11], rules out the possibility of treating it in the classical method of waste water treatment – nitrification and de-nitrification. This would require a class IV sewage plant, with the capacity to treat the volume of waste water produced by 10,000 to 100,000 people. With the hope for a simple solution to the digestate treatment problem dismissed for the above reason, only more complicated ways of treating contaminated water remain such as evaporation, stripping, flocculation and membrane techniques.

## 2. Basic Procedure

The first step in digestate treatment is usually the separation of the large particle fraction with a diameter greater 1 mm. This reduces the mass flow by around 10% when using a screw press. Further solid removal can be achieved through the use of vibrating screens,

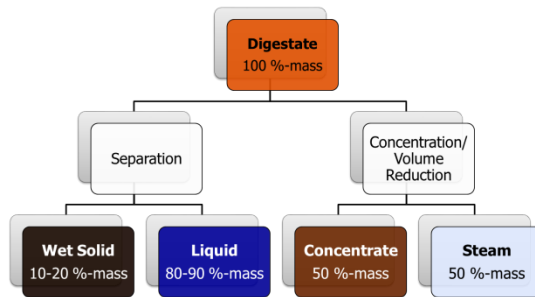

Fig. 1. Basic procedure for digestate treatment. Separation reduces the mass by 10 to 20% by solid removal, concentration leads to higher volume reduction; however, this incurs at higher costs and energy demands. Separation is usually a pre-treatment for more advanced processes

decanters, belt filter presses or flotation. Separation using these techniques can be enhanced by flocculation. The disadvantages of flocculation are the costs for the flocculant and the limitation of synthetic flocculants in fertilisers [6]. When separation is not the first step, an alternative, which is shown in Figure 1, is the volume reduction by the evaporation of water. This technique works well, even without solid removal. In this process, the digestate is concentrated by a factor of two. A maximum dry matter content of 15% can be achieved, this is true for all liquid digestates obtained from mesophilic digesters, as above this level, the digestate loses its ability to be pumped. This technique reaches an efficiency of  $0.6\div 1.0$  l/kWh [20].

### 3. Concentration

Concentration is performed using the CHP plant's water cooling system which is connected to a water-air heat exchanger. The dryer is either installed between the last digester and the digestate storage tank or parallel to the digestate storage tank as shown in Figure 2. Liquid digestate is pumped into the dryer and dried by the air that is taken from the environment and heated by the waste heat of the CHP plant. The air evaporates water from the digestate and simultaneously extracts some ammonium – this is removed from the exhaust air by a scrubber working with sulphuric acid.

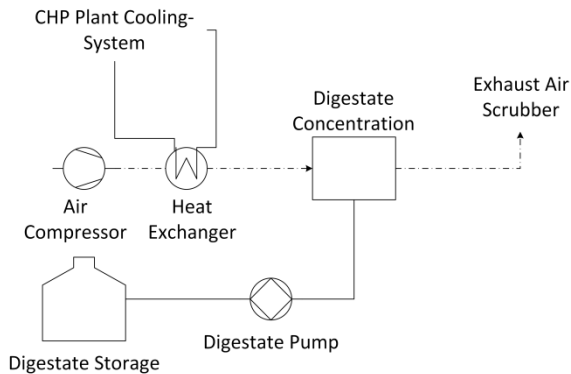

Fig. 2. Digestate dryer used as liquid digestate concentrator, installation parallel to the digestate storage

Such a concentrator device can be constructed with a tank containing the digestate and a drum, belt or disc that dips into the digestate and conveys it to the hot air for evaporation to occur. A large surface area ensures a high water extraction efficiency – the exhaust air should have at least 80% relative humidity. Another method is to use a belt dryer. In order to prevent liquid digestate leaking through the belt dryer's belt it is applied to dried solid digestate at the start. This results in a wet solid digestate which can then be dried. The product of this process cannot be pumped.

## 4. Separation

The main objective in separation is to achieve a high selectivity, meaning the solid fraction should have a high dry matter content, the liquid fraction should be particle free. Achieving both of these features at the same time is unfortunately impossible; however, with the right combination of separation techniques, it is possible to get a solid with a dry matter content of up to 35÷40% and a liquid phase with less than 2% dry matter content. Generally, it is observed that phosphate tends to stay with the solid fraction, while nitrogen – usually dissolved as ammonium – remains in the liquid phase [11].

As mentioned in Section 2, the first separation step is usually performed by a screw press. This is due to its energy efficiency of around 0.45 kWh/m<sup>3</sup> digestate and its durability. Its' products are a solid with a dry matter content of about 25÷35% and a liquid phase with a reduced dry matter content of between 0.5 and 2 %, depending on the dry matter content of the original digestate and the particle size distribution [11]. In case a particle sensitive treatment techniques follows downstream, the liquid phase needs further solid removal. All separation techniques are shown in Figure 3, the devices for further solid removal usually require an upstream flocculation. For further information about flocculation, see Section 5.

**Screw Press** In this device, digestate is introduced into a drum screen by a conveyor screw. The screen width varies between 0.5 and 1.0 mm; therefore, particles greater than this size are held back by it while the liquid phase and smaller particles pass through. The remaining solid is compressed towards the end of the drum screen by the conveyor screw, driving out more water. Flaps at the output support the accumulation of solids – these are used to adjust the compression pressure and thus, the dry matter content of the solid phase. A diagram of the screw press is shown in Figure 3(a). For enhanced solid removal, self-cleaning wire wedge filters can be supplemented to the separation system. These work similar to a vertically installed screw press, only with a finer screen and without resulting in the compression of the solid output.

**Decanter Centrifuge** This device is shown in Figure 3(b). The separation principle is based on gravity and the density difference of particles and liquid. The decanter consists of a fast rotating encasing drum and a slightly faster rotating conveyor screw, resulting in a relative rotational speed of the screw against the drum. The digestate is introduced through the drive shaft into the middle of the encasing drum. Due to their higher density, particles gather on the encasing drum's surface and are driven towards the output by the conveyor screw. The liquid squeezes through the slits between the drum and the screw to exit the decanter through the liquid's output. An overflow weir prevents particles from exiting at the liquid output. The process can be influenced by the rotational speed of drum and screw, the difference in rotational speed between drum and screw, the over flow weirs position and the mass flow through the centrifuge. The decanter centrifuge produces a very clear liquid fraction; however, the solid fraction still has a relatively high water content. Compared to the screw press, this is more sensitive to mechanical malfunction and its energy consumption is between 3 and 5 kWh/m<sup>3</sup> of digestate [11].

**Belt Filter Press** A diagram of the belt filter press operating principle is shown in Figure 3(c). The digestate is fed onto the belt filter, pre-dewatering is accomplished by gravity. Optionally, a vacuum can be applied in this zone to enhance the water extraction.

After the initial drainage, sludge is compressed between two filter belts that run between several rollers. The increased pressure drives out water as does the slight relative movement of the two filter belts. At the output, the belts separate and the solids are scraped off. Afterwards, the filter belts are spray washed. The solids output has a high dry matter content, the liquid phase quality depends on the belt filter and on flocculation. It consumes around  $0.88 \text{ kWh/m}^3$  of sludge.

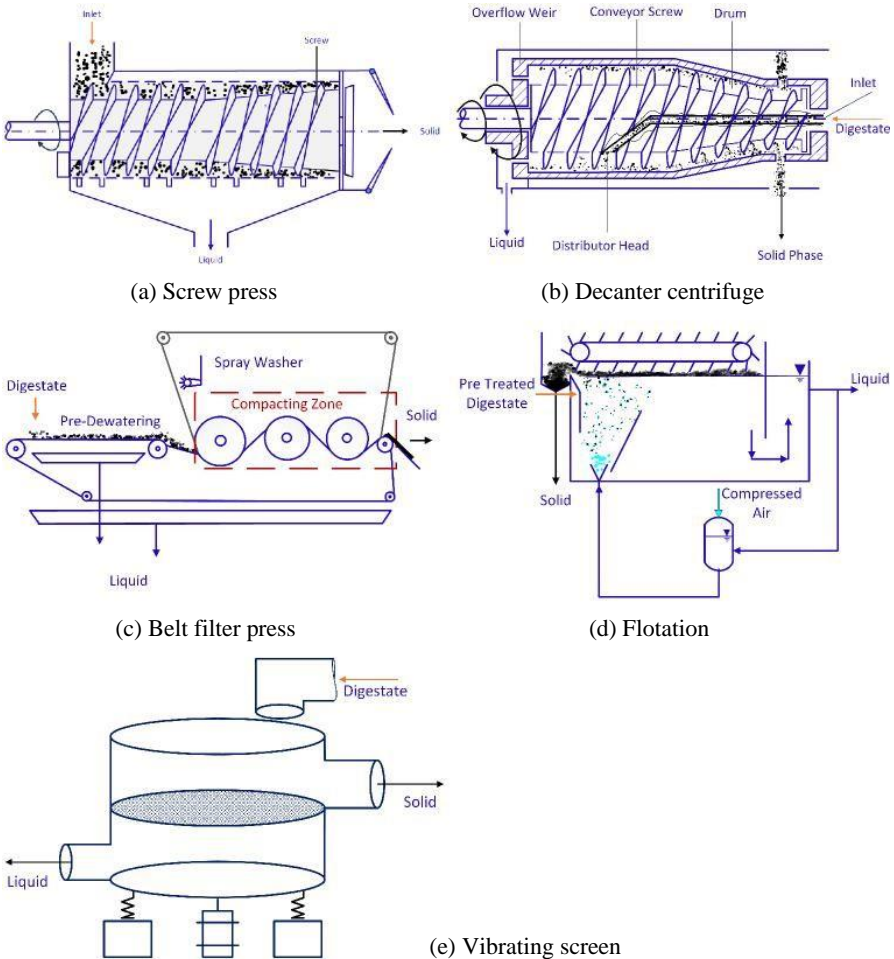

Fig. 3. Devices used for separation and further solid removal

**Flotation** The flotation separates particles by taking advantage of bubble formation on particle surfaces and hence, the density difference between liquid and the agglomerate of particle and bubble. Figure 3(d) illustrates the method of operation of this device. Air is diluted in liquid digester under pressure, the air-saturated liquid is then fed into the flotation tank through a relaxing valve. The diluted air changes state to gas and small bubbles form on

the particles' surface. The bubble-particle agglomerate is elevated by buoyancy and floating sludge builds up at the surface. This is scraped towards the overflow weir for the flotation sludge. For a cleaner liquid fraction, the output is partly recycled into flotation. The advantage of flotation is a very clean, near particle free liquid fraction. The flotation sludge still has a very high water content. This technique is only used for solid removal from liquids that already have a low dry

**Vibrating Screen** A vibrating screen is normally used for further solid removal after using a screw press or a decanter centrifuge, because even though a decanter produces very clean very high water content. This technique is only used for solid removal from liquids that already have a low dry matter content. Flotation takes around  $0.2 \text{ kWh/m}^3$  treated liquid, particles with a density lower than water can get through the gravitational field of a decanter. Figure 3(e) shows the application of a vibrating screen. Digestate is introduced onto the screen, liquid and small particles pass through whilst the remaining solid particles stay on top of the screen and move towards the solid outlet due to screen vibration. The typical width of a screen slit width is  $150\div 250 \mu\text{m}$  [11].

## 5. Flocculation

In order to enhance the separation processes, flocculation is often used in industrial applications. The trouble with digestate and its particles that won't sediment is that the particles repel each other because of their negatively charged surfaces. This prevents their agglomeration to bigger particles that are easier to remove [11]. Flocculation becomes important when a particle free liquid needs to be provided for membrane technologies. A reverse osmosis membrane is very sensitive to particles and requires pre-treatment by ultra-filtration – this involves high energy consumption when the concentration of solids is high. Therefore, whilst a well-performed flocculation reduces energy consumption, it requires extra operating resources such as the flocculant and the flocculant aid polymer.

Flocculation of digestate is carried out in two steps. Firstly, the flocculant – usually a water soluble metal salt such as iron-III-chloride – is added to the digestate. The highly-charged cations formed by the metal salt effect that the negatively charged particles suspended in the digestate agglomerate to slightly bigger particles, see Figure 4 on the left. Since these particles are still too small for separation, a flocculant aid polymer is added. This can be imagined as a long chain with negatively charged arms where the particle loaded metal cations connect to form a huge particle that can be easily separated.

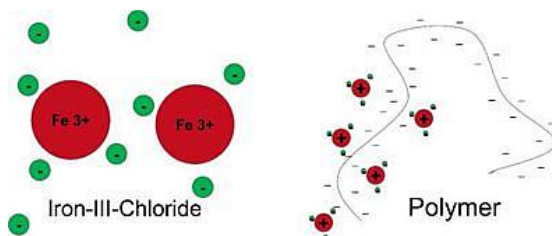

Fig. 4. Principle of flocculation

## 6. Further Treatment

After separation, a solid phase with a dry matter content of 25÷35% and a liquid phase with 1÷8% are obtained. Both can individually be treated further in order to remove more water, isolate certain plant nutrients and produce highly concentrated fertilisers as well as clean water.

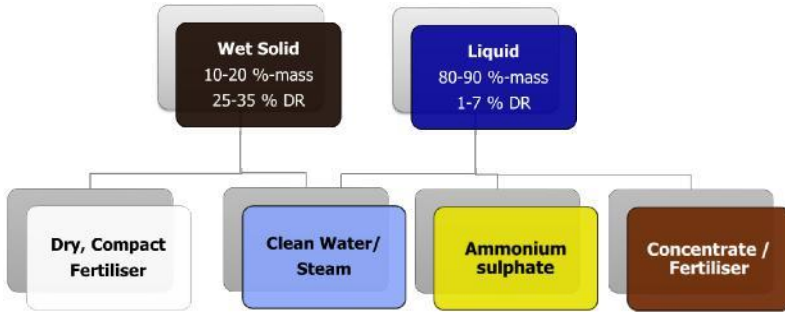

Fig. 5. Products of further treatment

### 6.1. Solid Phase

The further treatment of the solids amounts to further water removal and compaction. The devices used for these two steps work in similar ways. For the drying process the belt dryer is shown as an example, other constructions of dryers, such as drum dryer, feed-and-turn-dryer etc. follow the same working principle. Drying the solid phase of a digestate is only appropriate when there is enough heat available from the CHP plant. For pelleting the solid phase, its dry matter content should be between 86 and 90%; thus, if pellets are desired as a final product, drying is inevitable. The working principle of drying solids is the same as described for concentration in section 3. Using steam instead of air as a drying medium is more efficient due to the enhanced energy recovery [23]. However, steam dryers are not in standard usage for digestate drying – they are seldom used and expensive.

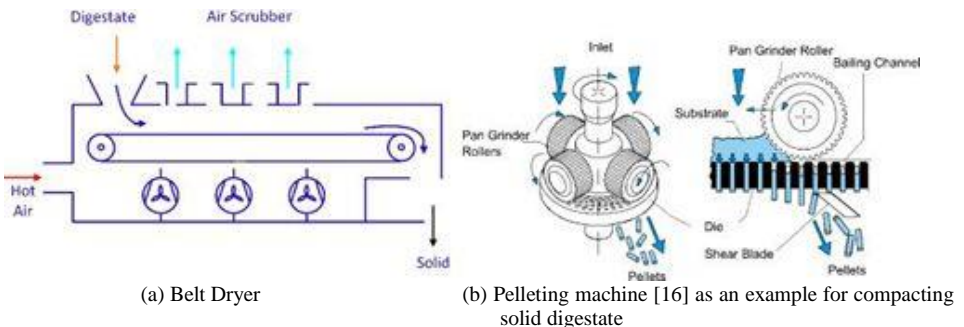

Fig. 6. Devices for further solid treatment

Dried solids have a bulk density of 250÷350 kg/m<sup>3</sup> whereas pellets bulk density ranges from 700÷750 kg/m<sup>3</sup>. This is a great advantage when the solids are supposed to be sold as a

commercial fertiliser since it improves the handling considerably. The compacting generally works by applying pressure to the solid material and forcing it through a tight die. This can be achieved either with a conveyor screw like in an extruder or by grinder rollers, that are used in a pelleting machine. Inside the bailing channels, the material is homogeneously compressed. The pellets' surface is coated with a thin shiny layer, which is the result of the effect of high pressure and temperature on lignin and cellulose. Figures 6(a) and 6(b) illustrate how both processes operate.

## 6.2. Vacuum Evaporation

The liquid digestate from the separation can be further concentrated through the use of vacuum evaporation. The benefit of using vacuum evaporation is that the boiling point of water is reduced to  $40\div 70^{\circ}\text{C}$ , depending on the absolute pressure. This enables the use of cooling water from the CHP plant that has a temperature of approximately  $85^{\circ}\text{C}$ . Furthermore, it reduces the amount of thermal energy needed to heat the digestate to its boiling point. In Figure 7, a flow chart for a single-step vacuum evaporator is presented to demonstrate the working principle. Liquid digestate enters the evaporator, which is connected to the CHP plant's cooling system. The applied vacuum reduces the boiling point to around  $60^{\circ}\text{C}$ , water is evaporated and dissolved gases like carbon dioxide and ammonia escape the liquid. Since digestate contains a lot of ammonium, the produced steam is rich in ammonia; this needs to be removed in order to obtain clean water. This is done by an acidic scrubber using sulphuric acid to turn the ammonia into ammonium sulphate. Afterwards, the steam is condensed and stored in a water tank. In order to remove all heat from the system, this water is used in an evaporative cooler. The energy demand of such a plant is around 13kWh electricity per cubic meter of digestate while 1.4 litres of water are removed with one kilowatt hour of thermal energy [21].

If evaporation takes place in more than one evaporator, it is possible to reuse the thermal energy. This is done by applying different pressures in the evaporation tanks and hence, achieve different boiling temperatures. The steam from the hottest evaporator is cooled and condensed in the first condenser while digestate from the second evaporator, working at lower temperatures, is heated and evaporated. Commercial systems use up to three evaporation steps, reaching a very high level of thermal energy efficiency.

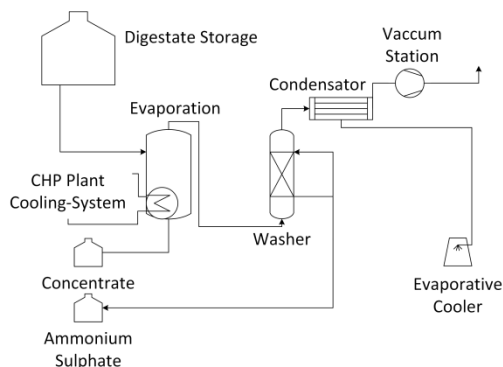

Fig. 7. Working principle of a single-step vacuum evaporation system



### 6.3. Ultra-Filtration and Reverse Osmosis

The membrane process is the most sensitive of the three described further treatment techniques. Even though ultra-filtration is used for the express purpose of removing particles, it can only cope with a maximum sludge concentration of 25 mg/l which is about equal to a dry matter content of 2.5%. [3] Therefore, an elaborate separation technique should be installed upstream. Therefore, the energy demand of ultra-filtration is increased by higher solid concentrations because this thickens the liquid and results in higher pressure loss. Another issue is the cleaning interval which also depends on the solid concentration in the input liquid. It is important that the ultra-filtration step reliably removes all particles from the liquid. This is because of the small liquid channels inside the reverse osmosis modules that are blocked by particles very easily.

The way the membrane system as shown in Figure 8 works is, that the ultra-filtration removes all solids from the liquid digestate. Usually, a feed and bleed circuit is used in these kind of systems. This means that a small pump ensures the required transmembrane pressure difference in the ultra-filtration cycle and a large pump circulates the fluid through the membrane. The retentate is rich in organic matter and usually recycled to the fermenter. The permeate is introduced into the reverse osmosis process. This works in two steps: firstly, most salts and dissolved substances are removed. Since ammonium always stays in a state of dynamic equilibrium with ammonia, the permeate of the first step still contains a major fraction of it. Ammonia is not held back by membranes; therefore, sulphuric acid is added to the permeate of the first reverse osmosis step turning ammonia into ammonium, which can be held back by the membrane in the second reverse osmosis step. The permeate of the second step is clean water, that can be introduced into the environment<sup>1</sup>. The retentate is reintroduced to the first step of reverse osmosis. The first step retentate is therefore rich in ammonium sulphate.

The operation costs are dominated by the use of electrical energy. Processing one cubic meter of digestate with a membrane process requires approximately 21 kWh of electricity. This also includes digestate separation prior to the membrane process [27].

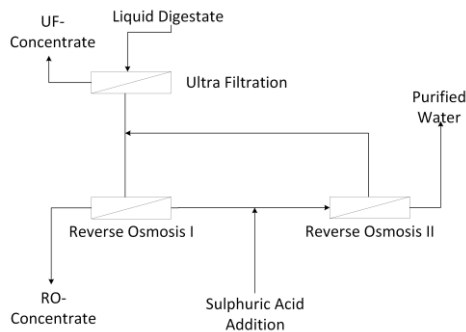

Fig. 8. Membrane process for total digestate treatment

<sup>1</sup> The permeates concentration of pollutants is very low and should not cause a problem for the environment; however, there is no mention of waste water from bio-digesters in the German waste water decree, making it hard to achieve permission for waste water discharge.

## 6.4. Stripping

The stripping process is used to remove ammonium from the digestate and fermentation process. It involves the separation of solids before stripping, which however, is not as complicated as for the membrane process. Unlike vacuum evaporation and membrane treatment, clean water is not obtained through this process. Figure 9 shows a flow chart of an ammonia stripping process connected to a digester.

For this process, the coarse solid fraction is removed from the digestate. The liquid phase is heated and sodium hydroxide is added to increase the pH and hence, move the ammonia/ammonium equilibrium toward the ammonia side to increase its volatility.

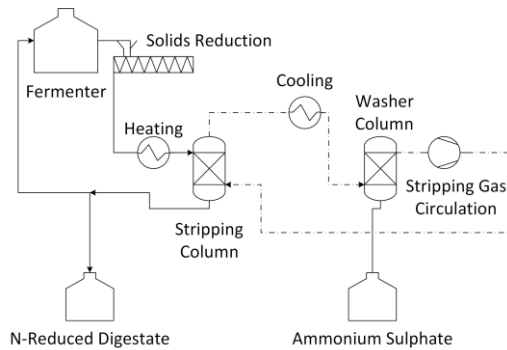

Fig. 9. Stripping process to reduce the ammonium concentration in the digestate and inside the fermenter

Afterwards, the liquid is introduced into a column, where a stripping gas (mostly steam) is used to extract the ammonia from the liquid. After this stage, the nitrogen-reduced liquid digestate either flows back into the digester or to a storage tank. The stripping gas needs to be recovered. Thus the stripping gas is introduced in a washer column where the ammonia is removed with the aid of sulphuric acid, forming ammonium sulphate – the second product of ammonia stripping.

The advantage of ammonia stripping is high flexibility in the choice of substrate for the digester, enabling the use of dry chicken faeces in large proportions. The energy demand of a stripping system is 90 kWh thermal energy and 7 kWh electrical energy per cubic meter of digestate [12].

## 7. Summary

All described steps of digestate treatment can be summarised in a digestate treatment flow chart shown in Figure 10. Each step involves a greater effort but simultaneously, a higher value product. The only exception in this chart is the stripping, which is a process that not only treats the digestate but also influences the behaviour of the fermenter. The actual effort for stripping equals a three-step treatment such as vacuum evaporation or membrane treatment.

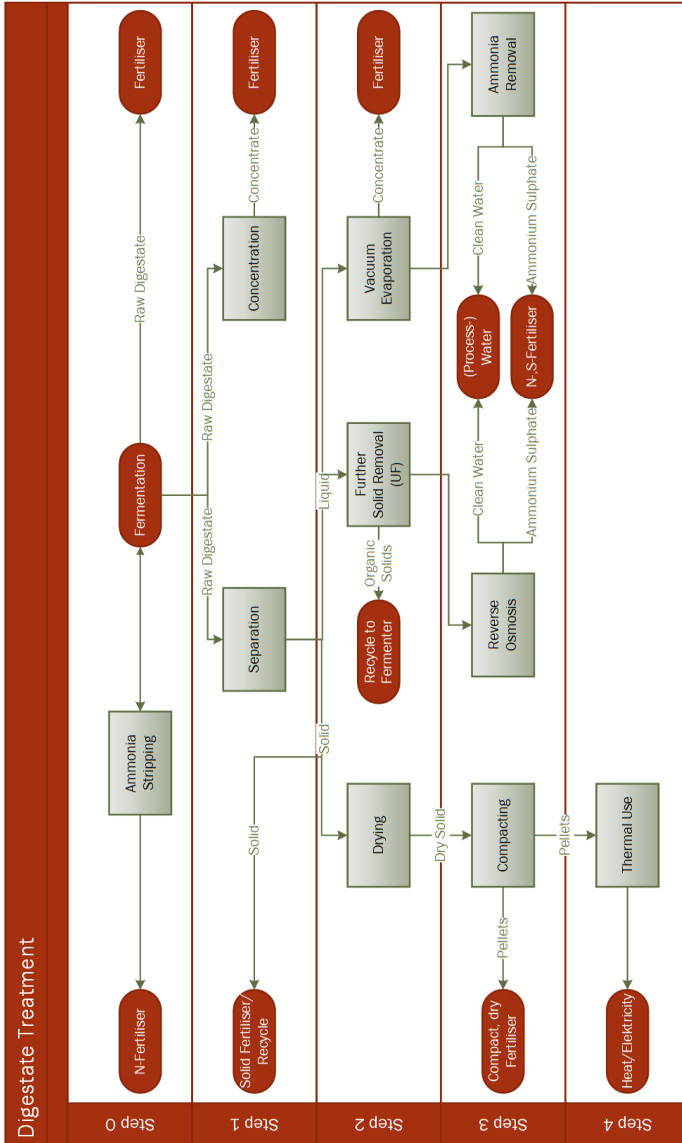

Fig. 10. Digestate treatment techniques flow chart

### References

[1] Amlinger F., Peyr S., Hildebrandt U., Müssen J., Cuhls C., Clemens J., *Stand der technik der kompostierung*, Bundesministerium für Land- und Forstwirtschaft, Umwelt und Wasserwirtschaft, 2005.

- [2] Bauermeister U., *Erzeugung von konzentriertem Stickstoffdünger aus Gärprodukten – Einsatzmöglichkeiten und Praxiserfahrungen des ANAStrip-Verfahrens*, 2013.
- [3] Berghof Membrane Technology GmbH & Co. KG., *Bioflow Membrane Manual*, <http://adurna.in/documents/Bioflow.pdf>.
- [4] BIGATEC – Ingenieurbüro für Bioenergie. <http://www.bigatec.de>.
- [5] Bundesministerium der Justiz und für Verbraucherschutz. Gesetz für den Ausbau erneuerbarer Energien (Erneuerbare-Energien-Gesetz-EEG 2014): EEG2014.
- [6] Bundesministerium der Justiz und für Verbraucherschutz. Verordnung über das Inverkehrbringen von Düngemitteln, Bodenhilfsstoffen, Kultursubstraten und Pflanzenhilfsmitteln (Düngemittelverordnung - DüMV), 2012.
- [7] Bundesministerium für Umwelt, Naturschutz, Bau und Reaktorsicherheit. Verordnung über Anlagen zum Umgang mit wassergefährdenden Stoffen (AwSV). [http://www.bmub.bund.de/fileadmin/Daten\\_BMU/Download\\_PDF/Binnengewasser/awsv\\_bf.pdf](http://www.bmub.bund.de/fileadmin/Daten_BMU/Download_PDF/Binnengewasser/awsv_bf.pdf).
- [8] Dorset Agrar- und Umwelttechnik GmbH.
- [9] Fachverband Biogas e.V., editor. *23. Jahrestagung und Fachmesse: Aufbereitung und Vermarktung von Gärprodukten*, 2014.
- [10] Förstner U., *Umweltschutztechnik* (German Edition), Springer, 8. Aufl. 2012.
- [11] Fuchs W., Drosig B., Peter H., Klumpp H., *Technologiebewertung von Gärrestbehandlungs- und Verwertungskonzepten*, Eigenverlag der Universität für Bodenkultur, Wien 2010.
- [12] GNS – Gesellschaft für Nachhaltige Stoffnutzung [mbH. www.gns-halle.de](http://www.gns-halle.de).
- [13] Hornung A., *Konzept der Biobatterie*, 2013.
- [14] HUNING Umwelttechnik GmbH & Co. KG.
- [15] Jung R., *Effizienzsteigerung von Biogasanlagen durch Pyrolyse von Gärresten*, 2014.
- [16] Kaltschmitt M., Streicher W., *Energie aus Biomasse*, Springer, 2. edition, 2009.
- [17] Köhnlechner M., *Volumenreduktion und Veredelung von Gärprodukten* [in] *Fachverband Biogas e.V.*, editor, 23. Jahrestagung und Fachmesse, 2014, 28-36.
- [18] Lehmann T., *Aufbereitung von Gärresten zur stofflichen und energetischen Nutzung*, 2013.
- [19] Lehmann Maschinenbau GmbH.
- [20] Burkhard Meiners, 2014.
- [21] MKR Metzger GmbH.
- [22] Röhren- und Pumpwerk BAUER GmbH.
- [23] Seefeldt F., Berewinkel J., Lubetzki Ch., *Energieeffizienz in der Industrie*, Springer, 2009.
- [24] Sommer K., *CULTAN-Düngung: physiologisch, ökologisch, ökonomisch optimiertes Düngungsverfahren für Ackerkulturen, Grünland, Gemüse, Zierpflanzen und Obstgehölze*, Mann 2005.
- [25] Steros GmbH.
- [26] Thermo-System GmbH.
- [27] Brüß U., *MPS Verfahren zur Totalaufbereitung von Gärresten* [in] *Fachverband Biogas e.V.*, 23. Jahrestagung und Fachmesse, 2014, 13-27.
- [28] Drasden Venturi GmbH Energieanlagen and GMBU e.V., Halle, *Untersuchung zur Rohstoffseparation aus Gärresten*, 2013.