

MAREK KRYNKE\*

## NUMERICAL ANALYSIS OF BOLTS LOADING IN SLEWING BEARING

---

## ANALIZA NUMERYCZNA OBCIĄŻENIA ŚRUB W ŁOŻYSKU WIEŃCOWYM

### Abstract

This article analyzes screw connection of slewing bearings to various structures of support elements. The susceptibility of support elements to the load distribution in particular bearing screws was examined by means of the Finite Element Method. The load values of screws and their distribution around the perimeter of the combined bearing rings were also specified.

*Keywords: slewing bearings, bolt connections, load capacity bearings*

### Streszczenie

W niniejszym artykule dokonano analizy połączenia śrubowego mocującego łożysko wieńcowe do różnych struktur jego zabudowy. Korzystając z metody elementów skończonych, zbadano wpływ podatności podzespołów wsporczych na rozkład sił przypadających na poszczególne śruby mocujące łożysko. Określono wartości obciążenia śrub i ich rozkład po obwodzie łączonych pierścieni łożyska.

*Słowa kluczowe: łożyska wieńcowe, połączenia śrubowe, nośność łożysk*

**DOI: 10.4467/2353737XCT.16.237.5986**

---

\* Ph.D. Eng. Marek Krynke, Institute of Production Engineering, Faculty of Management, Czestochowa University of Technology.

## 1. Introduction

In the construction of heavy machinery, large-size bearings called slewing bearings are used to embed the body performing the rotation motion on the chassis. These bearings are connected to the seats of a work machine with a pre-tight bolted joints. Fastening the screws of slewing bearing rings to supporting structures is an important piece of the entire mechanism of rotation which to a large extent affects the rigidity of bearing rings, while bolts strength often determines the carrying capacity of the entire working system [8, 10].

Methods which are available in the literature for determining the slewing bearings load capacity often do not include the impact of susceptibility of supporting components and the bearing mounting bolts [1, 6]. These factors can only be taken into account by using numerical methods.

The main cause of screw connections failure during the life of slewing bearings is believed to be, besides material cause, insufficient rigidity of load-bearing elements in substantial warping of the contact surface of the flange. In fact, a lot of devices, because of the limitation of the height of the rotary node, fails to construct a sufficiently rigid framework stiffness which does not change by leaps and bounds, which is the cause of the distribution forces occurrence in the bearings considerably different from the projected. This is confirmed by a series of experimental and simulative research presented in the works [2, 3, 5, 9].

In this chapter, distributions of forces in each slewing bearing fastening screws which are built in different support components have been presented and compared (Fig. 1). Also, points of excessive load carried by bearing which is working in components that do not provide adequate support for the slewing bearing have been indicated.

## 2. Subassembly support and slewing bearing

There are several constructions of support subassemblies which have a differentiated structure, shaped by reason of the load carried, type of installation, etc. This analysis focuses on three different support components (Fig. 1). The supporting structures are different from each other in the fitting of slewing bearing. The first and second support component consists of a plate mounted on stringers which are made of plates welded together to form a closed cross section box (Fig. 1a, b). In the third subassembly, a ring girder in the form of a thick-walled sleeve with a flange for mounting the bearing is used instead of a plate. All the three support frame substructures have two planes of symmetry.

For the calculation, a catalog of single row slewing ball bearing of four-point contact is assumed (Fig. 2) [7]. In this bearing, there is one row of balls and each ball cooperates with two pairs of raceways.

The study analyzed bearings with the following parameters:

- rolling diameter  $d_t = 1400$  mm,
- balls diameter  $d = 40$  mm,
- balls number  $z = 84$ ,
- coefficient of balls to the raceway adhesion  $k_p = 0,96$ ,
- nominal contact angle  $\alpha_0 = 45^\circ$ ,

- raceway hardness – 54 HRC,
- number of fastening screws – 36 screws M24-10.9 in each ring.

In addition, it was assumed that:

- raceway surfaces and the rolling elements have an ideal shape, and all parts of the roller have the same diameter,
- materials of rings and rolling elements are homogeneous and isotropic.

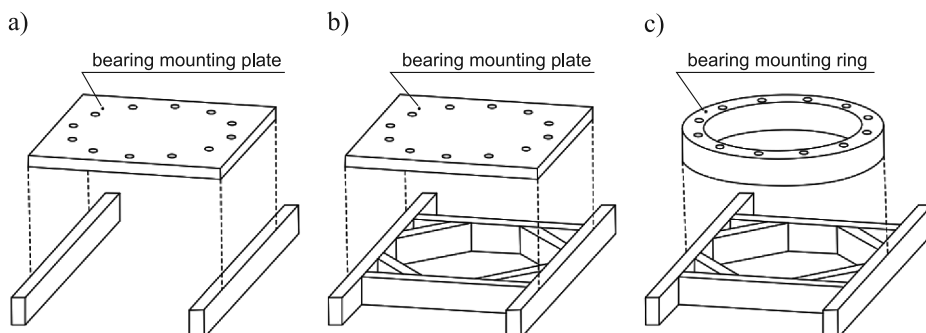

Fig. 1. Frame without gussets near mounting holes requires thicker plate1 – model (a), Gussets added near bearing mounting holes increase rigidity – model V2 (b), Gussets added near mounting holes and ring replace plate for additional rigidity – model V3 (c)

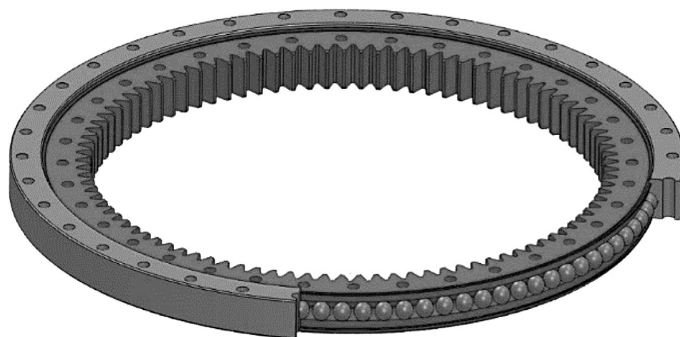

Fig. 2. Four-point contact ball slewing bearing

### 3. Numerical computations

Slewing bearing is a complex structure. The computational model of the bearing was made by means of the Finite Element Method (Fig. 3) [4]. The slewing bearing uses a large number of contact zones (sometimes hundreds). To avoid an undesired increase in the size of the numerical model, a part of the rolling bearing is replaced by the so-called super-elements introduced, among others, in [8]. The main portion of the super-element is a rod element with a nonlinear characteristic which is determined on the basis of a substitute characteristics of contact zone [2].

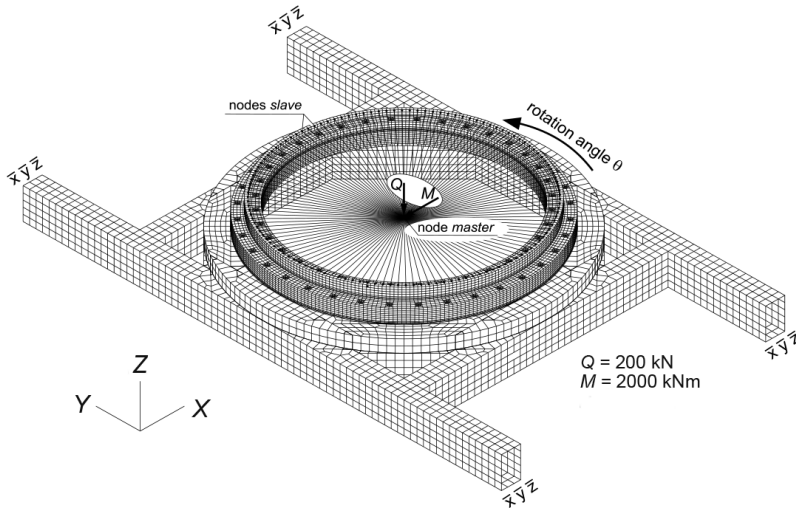

Fig. 3. FEM model of the subassembly support and slewing bearing with boundary conditions marked

For the discretization of bearing rings, plate and girder ring gear, 8-node type components 3D-SOLID were used. The discretization of stringers components in subassembly support was made by means of shell elements such as SHELL. In the geometric models, only the most important elements that affect the rigidity of load-bearing frames were included. In this study, it was assumed that the bolts are modeled by means of special beam elements, which can be attributed to founded preload [4]. In addition, the following simplifications were introduced:

- all walls and ribs were decided to be considered as the surfaces,
- gear of bearing rings was omitted,
- minor construction details, such as sealing grooves, lubricants holes, etc. were omitted.

One of the bearing construction girders, which is associated with the support component, is called the support girder. The load is applied to the second girder called the load girder. Conditions were defined between the respective surfaces of the bearing rings and the surfaces of his mounting contact.

#### 4. Analysis of the obtained results

Calculations were performed for all the three computational models designated as V1, V2 and V3. The purpose of the calculations was to determine the forces acting on individual parts of rolling bearing and bolts that attach the bearing to the support structures. This chapter focuses on the analysis of the screw connection, while the load range of the rolling elements was addressed in work [4]. In the analyzed types of supporting structures (V1, V2, V3), different positions of the body during its rotation angle  $\theta$  are included. With the use of the symmetry of tested models, analyzes were performed for the angle  $\theta = 0 - 90^\circ$ . The load

which was adopted for the calculation was the axial force  $Q = 200$  kN, and a cranky moment amounted to  $M = 2000$  kNm. This is the limit load resulting from the sheet characteristic of load ratings [7].

Figure 4 shows the maximum load of the bearing mounting screws as a function of the position of the load girder.

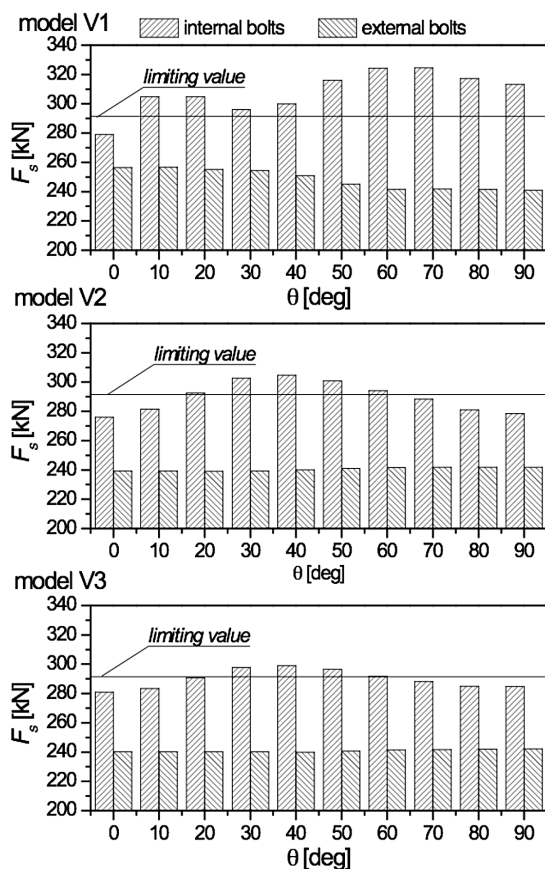

Fig. 4. The maximum force in the bearing fixing bolts for the different positions of the support subassembly ( $\theta = 0 - 90^\circ$ )

The presented results show that in the case of all the types of analyzed support structures, the limit bolt load was exceeded (Fig. 4), which could result in damage of the bearing raceway. In the accompanying drawings it can also be seen that in the case of models V2 and V3, the largest load of bearing raceways exists for the body position of angle of approximately  $40^\circ$ .

## 5. Conclusions

The study indicates how important in the design of slewing bearings is the appropriate design of bolted joints. It has been shown that in the analyzed screw connection, significant changes occur in the load of each bolt connecting the bearing rings with the supporting structures. This is important because often a carrying capacity of the whole unit determines the strength of the bolts. The results of the mentioned analyzes indicate that the screw connections of slewing bearing rings carry uneven loads, particularly in cases where it does not have a sufficient rigidity of the supporting structure. If the limit values are exceeded in any of the mounting screws, we need to change the design of the connection, i.e. select bolts of a larger diameter or higher strength class, increase the number of screws or change the design of the connection (to increase rigidity). Breaking of even one bolt in the connection quickly leads to severing of the remaining screws, which ends with a serious failure of the whole unit.

The analysis demonstrates the validity of numerical methods in practical engineering calculations. It allows for the precise distribution of forces transmitted by each bearing rolling elements. Such modeling allows for the quick verification of all technological design changes introduced to both bearing geometry and building structure.

## References

- [1] Kania L., Krynke M., *Computation of the general carrying capacity of slewing bearings*, Engineering Computations, vol. **30** (7), 2013, 1011-1028.
- [2] Kania L., Krynke M., Mazanek E., *A catalogue capacity of slewing bearings*, Mechanism and machine theory, vol. **58**, 2012, 29-45.
- [3] Kania L., Śpiewak S., *Influence of radial forces on change of friction torque in twin slewing bearing*, Machine Dynamics Research, vol. **38**, 2014, 121-131.
- [4] Krynke M., Borkowski S., *Wpływ postaci konstrukcyjnej podzespołu wsporczego na dystrybucję obciążeń w łożysku wieńcowym*, Przegląd Mechaniczny, vol. **7-8**, 2014, 23-29 [in Polish].
- [5] Krynke M., *The dynamic state monitoring of bearings system*, Production Engineering Archives, vol. **6** (1), 2015, 35-38.
- [6] Mazanek E., Krynke M., *Możliwości modelowania śrub mocujących łożysko wieńcowe*, Transport Przemysłowy i Maszyny Robocze, vol. **2** (8), 2010, 53-57 [in Polish].
- [7] ROTHER ERDE – Slewing Bering, Catalog 2008.
- [8] Smolnicki T., *Wielkogabarytowe toczne węzły obrotowe. Zagadnienia globalne i lokalne*, Oficyna Wydawnicza Politechniki Wrocławskiej, Wrocław 2013 [in Polish].
- [9] Szataniak P., Mazur M., Ulewicz R., Novy F., *Fractographic analysis of hardox steels research in the field of high-cycle fatigue regime*, Communications Scientific Letters of the University of Žilina, vol. **18**, 2016, 89-92.
- [10] Ulewicz R., Jelonek D., Mazur M., *Implementation of logic flow in planning and production control*, Management and Production Engineering Review, vol. **7** (1), 2016, 89-94.