

MICHAŁ KLUZIEWICZ\*

## EXPERIMENTAL VERIFICATION OF KINETOSTATIC MODEL OF STRUT SUSPENSION MECHANISM

---

### EKSPERYMENTALNA WERYFIKACJA KINETOSTATYCZNEGO MODELU MECHANIZMU ZAWIESZENIA Z KOLUMNĄ PROWADZĄCĄ

#### Abstract

The process of experimental verification of the MacPherson-strut mechanism model is presented. The mentioned model is used to estimate wheel load components based on measured internal reaction forces. Chosen constructional solutions of sensors mounting are described along with sensors calibration methods. The kinematic characteristics of a model and real suspension mechanism (measured on a test stand) are compared.

*Keywords: vehicle dynamics, MacPherson strut suspension modeling, measuring loads on a rotating wheel*

#### Streszczenie

W artykule przedstawiono przebieg doświadczalnej weryfikacji modelu mechanizmu prowadzenia koła. Model ten służy do estymacji składowych obciążenia koła jeźdnego samochodu na podstawie mierzonych sił wewnętrznych w przegubach. Zaprezentowano rozwiązania konstrukcyjne zabudowy czujników oraz metody ich kalibracji. Porównano charakterystyki kinematyczne modelu i rzeczywistego mechanizmu zmierzone na stanowisku badawczym.

*Słowa kluczowe: dynamika samochodu, modelowanie zawieszenia z kolumną MacPhersona, pomiar sił i momentów działających na koło*

---

\* M.Sc. Michał Kluziewicz (Ph.D. Student), Institute of Automobiles and Combustion Engines, Faculty of Mechanical Engineering, Cracow University of Technology.

## 1. Introduction

The issue of vehicle motion modelling requires implementing the characteristics of examined tires [8]. Among the known methods of tire characteristics estimation the measurement can be conducted either on test benches or in real conditions using a test vehicle and a circuit [4]. The author's main research is focused on a development of a tire-to-gravel surface interaction model. For the use of the mentioned application, in a view of best conditions representation, it is crucial to conduct appropriate road tests.

Having regard to the high purchase cost of direct measuring hubs and tough working conditions, the innovative authorial measuring system enabling indirect tire characteristics estimation has been designed [2]. This system exploits an existing MacPherson strut suspension. One mechanism performs various roles: wheel guiding, shock absorbing and reaction forces measuring in rod joints (Fig. 1). In respect to the known tire-surface case studies, this type of measuring device has not been used for road tests before.

Measuring forces and moments in a point of contact between tire tread and road surface is the main goal of the research. A scientific method of computing longitudinal and transversal tire force characteristics of a vehicle running on a loose surface is presented. The described approach is indirect and based on a measurement of internal forces and suspension mechanism configuration coordinates. The torques and forces relation is described by Jacobian matrices. The computer aided calculations are programmed and executed in the Matlab environment.

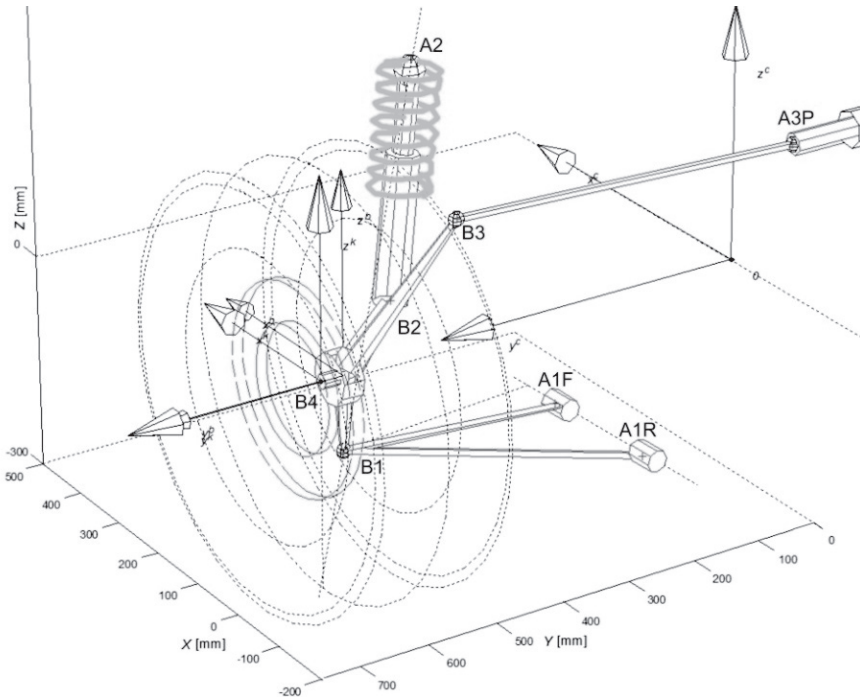

Fig. 1. 3D solid model of Citroen Saxo MacPherson strut suspension

The verification of the formula by a comparison of model and real measured kinematic characteristics is included. The designed and manufactured components of the measuring system are described along with the sensor calibration procedure. Geometric, kinematic and quasi-static (forces and torques estimation) descriptions of the suspension mechanism are presented.

The featured test vehicle is a front wheel drive, fully rally-prepared Citroen Saxo VTS, with a MacPherson strut front suspension.

## 2. Task definition of load estimation

External loads' characteristics ( $F_x, F_y, M_z$ ) in the point of contact between the tire tread and road surface are assumed as in the following equation [2]:

$$F_x, F_y, M_z = f(F_z, \gamma, \alpha, S_x, \beta, T_b, r_d, \text{surface parameters}) \quad (1)$$

where:

- $F_x, F_y, M_z$  – Tire load components estimated by internal loads of suspension mechanism in a specific suspension travel position ( $s$ ) and steering rack setting ( $p$ );
- $F_z$  – Tire vertical load, measured indirectly through suspension travel and force in the top mount;
- $\gamma$  – Wheel camber angle, estimated by: known suspension dimensions, measured suspension travel ( $s$ ), steering rack setting ( $p$ ) and chassis roll angle;
- $\alpha$  – Tire slip angle, estimated via longitudinal and lateral vehicle speed (Correxit QL) and steering wheel rotation angle (cable sensor);
- $S_x$  – Longitudinal tire slip, estimated via vehicle speed, wheel rotation speed, and dynamic wheel radius;
- $\beta$  – Vehicle sideslip angle, calculated from longitudinal and lateral vehicle speed;
- $T_b$  – Tire tread temperature, measurement is conducted with pyrometer gauge;
- $r_d$  – Dynamic wheel radius, estimated via axial force in a damper module.

Surface parameters such as loose layer depth, size distribution, moisture content, soil volume density.

A kinematic model of MacPherson strut suspension (Fig. 1) was formulated according to the following assumptions: quasi-static conditions; internal forces in a suspension are determined by method of joints; direct kinematic task is solved using the vector method [5].

For a specified mechanism setting, defined by suspension travel ( $s$ ) and the steering rack's position ( $p$ ), a static task can be described by the following equation:

$$\mathbf{W} = \mathbf{J}^T \mathbf{R} \quad (2)$$

where:

- $\mathbf{W} = [F_x \ F_y \ F_z \ M_x \ M_y \ M_z]^T$  – complex load vector translated to the wheel's centre of rotation,
- $\mathbf{R} = [R_1 \ R_2 \ R_3 \ R_4 \ R_5 \ R_6]^T$  – internal loads vector:  $R_1$  – reaction in a front wishbone rod joint;  $R_2$  – reaction in a rear wishbone rod joint;  $R_3$  – reaction in a steering rod;  $R_4, R_5, R_6$  – longitudinal, lateral and vertical reactions in a strut top mount,
- $\mathbf{J}$  – jacobian matrix for static analysis of parallel mechanism [5].

Equation (2) describes linear relations between an unknown external load ( $\mathbf{W}$ ) and the measured internal load ( $\mathbf{R}$ ) in the mechanism. Forces and torques in the centre of wheel rotation are related with joints reactions by the jacobian matrix. The jacobian matrix is determined for a specific suspension travel position ( $s$ ) and steering rack setting ( $p$ ).

### 3. Kinematic characteristics of wheel suspension

For the purposes of kinematic analysis, the 3d solid model of MacPherson suspension of a Citroen Saxo test car is implemented into the Matlab software. Subsequently, the mechanism is strictly measured and the gathered data is entered. At this stage, with the aim of verifying kinematic relations, the following values were measured as a function of suspension travel ( $s$ ): camber angle ( $\gamma$ ) [ $^\circ$ ], toe ( $\delta$ ) [mm], track width change [mm].

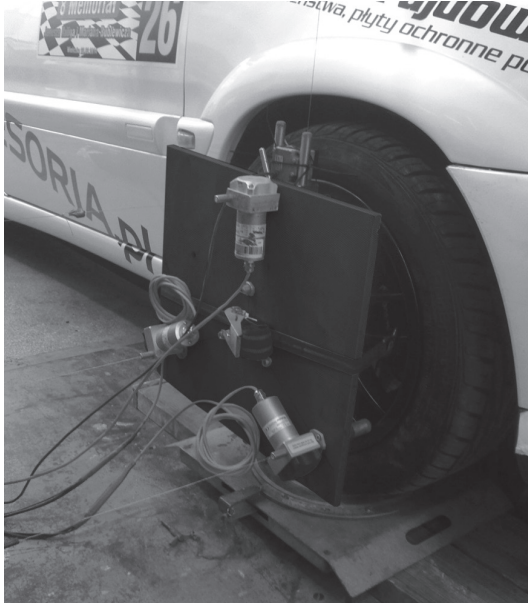

Fig. 2. Measuring adapter with 4 cable sensors attached to the wheel

Front wheels were set on turntables to avoid the influence of tangent forces. The front axle was supported with a jack and loaded with weights of the total of 300 kg. A measuring plate with 4 cable sensors was mounted to the rim (Fig. 2). One of the cables was attached to the car body in order to measure the suspension travel. Other three cables were fixed to the solid pillar. By measuring displacements of equilateral triangle vertices, the aforementioned values change can be obtained [1]. The data was logged with Spider 8 data acquisition system and the Catman module.

The measured real suspension characteristics (green) were compared to the corresponding ones received from a kinematic model (black) (Fig. 3).

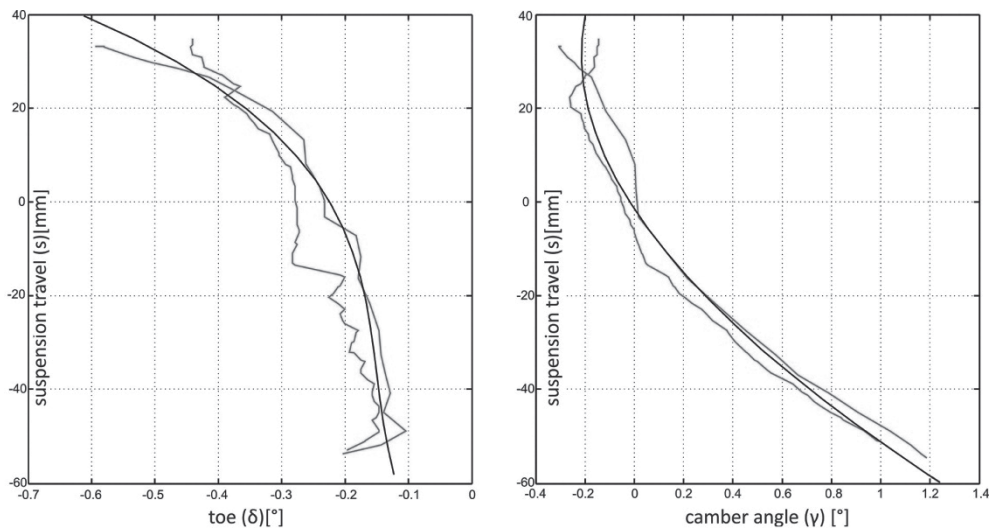

Fig. 3. Plot of a toe change and camber angle change as a function of suspension travel

Both presented characteristics retrieved from the model are fair representations of real traces. On this basis, it can be concluded that the kinematic model is properly specified. To obtain improved results, steering rod length should be precisely measured.

#### 4. Designed solutions of measuring system

Kistler 3-axis force sensor is mounted in a strut top mount (Fig. 1, point A2) and used for longitudinal, vertical and transversal (lateral) force measurement. Rubber bushing is replaced with uniball, thereby pliability and internal friction of joint are negligible (Fig. 4a).

A 3-component force sensor is used for the dynamic and quasistatic measurement of the three orthogonal components of any force acting on the top and bottom plate. It contains three pairs of quartz force measuring elements, one of which is sensitive to pressure in the z direction and two others to shear forces in the x and y directions. Measurement takes place practically without displacement [10]. As the effect of force acting on quartz elements, charges occur at the connections. Charges are converted to a  $0\div 10$  V signal by an industrial charge amplifier. Afterwards, the voltage signal from three separate channels is gathered by the data acquisition system and logged.

#### 5. Calibration procedure of load sensor in top mount

Proper axial tension is crucial for transverse and longitudinal shear forces transmission through static friction from the top and base plate to the surfaces of the force transducer.

Tensile forces are measured as a relief of the preload. Adequate contact surface preparation and preload ensures high rigidity and accuracy (Fig. 4b).

Irrespective of the given calibration certificate, the sensor was tested under various load states to determine the sensitivity of a complete measuring arrangement.

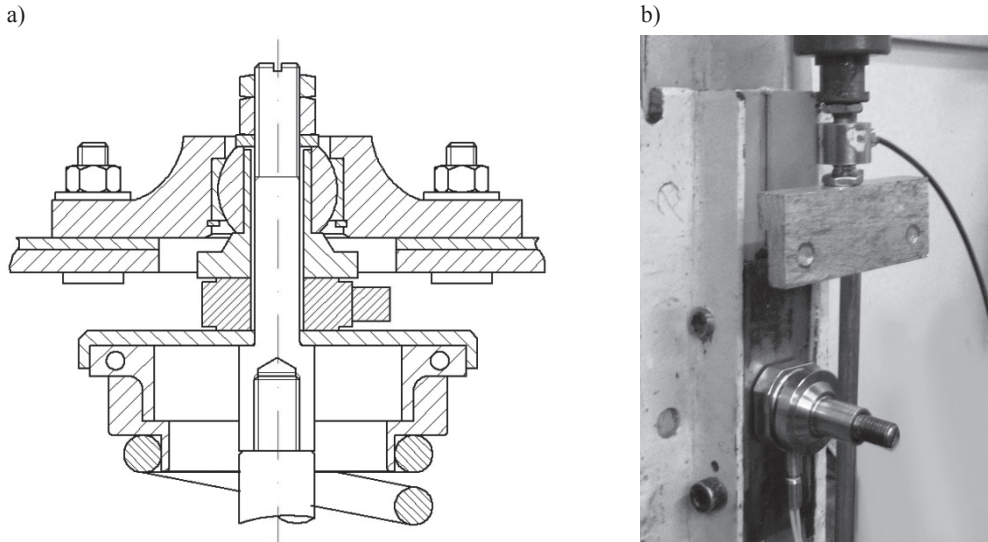

Fig 4. a) Simplified drawing of designed MacPherson strut top mount with 3-axis ( $F_x$ ,  $F_y$ ,  $F_z$ ) force sensor (blue), adapters and preload bolt, b) On-site sensor assembly

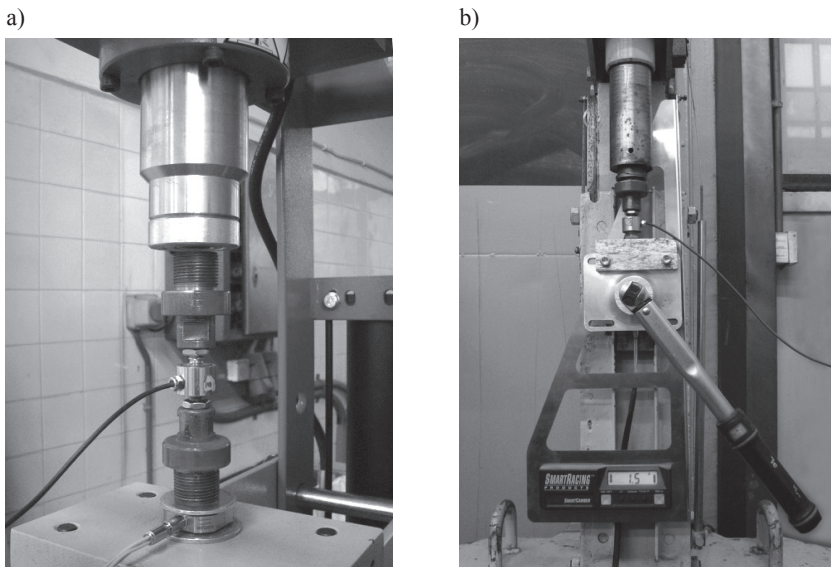

Fig. 5. a) Test stand 1 for calibration of  $F_z$  load component, b) Test stand 2 for a complex load state

The first test was aimed at correlating readings from the mentioned piezoelectric sensor and factory calibrated HBM U9C strain gauge. Both sensors were simultaneously squeezed onto a hydraulic press (Fig. 5a). The Z force values from a HBM sensor were assumed as a reference. The executed benchmark confirmed good linearity of the measured values (Fig 6). The obtained sensitivity insignificantly differs from the one provided by a manufacturer. While measuring miniscule loads (1000 N or less) without a preload, extra caution is recommended because of the sensor nonlinearity.

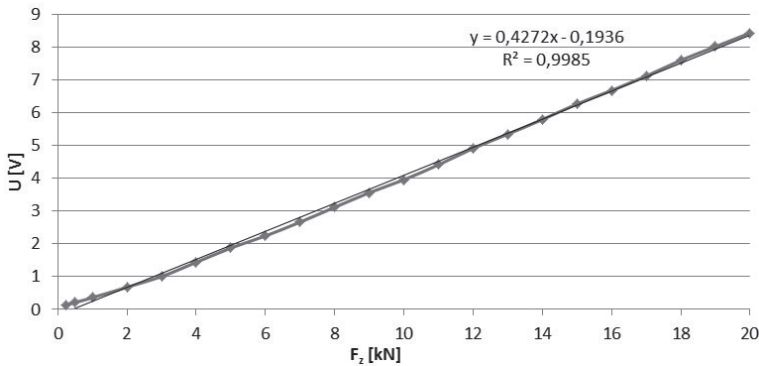

Fig. 6. Output voltage of a 3-axis sensor as a function of vertical load  $F_z$

In order to provide a desirable sensor preload, torque wrench is used for tightening the measuring structure (Fig. 5b). The preload bolt has a M12x1.75 metric thread which is coated with a copper slip. The relation between the tightening torque and compressive force is close to linear and the ratio is around 50 N/Nm.

As the final step, a complete structure of the suspension strut top mount was assembled and tested to prove usability of the sensor in complex load states (Fig. 5b).

The tension bolt was tightened with a torque of a 60 Nm, resulting in a 30 000 N preload force in a Z-axis direction. Subsequently, a screw press was used to exert loads from  $-3$  kN to 5.5 kN in axis  $X$  (Fig. 7).

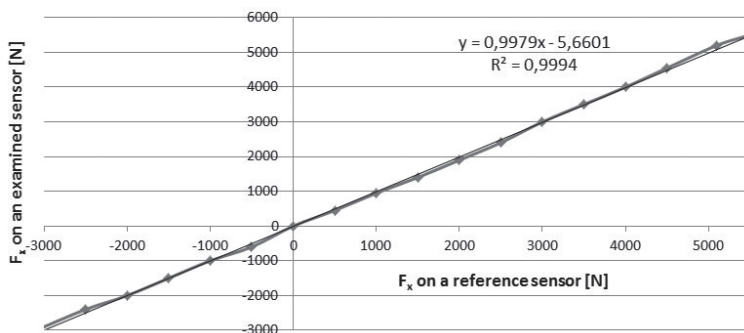

Fig. 7. Relation between  $F_x$  readings on an examined and a reference sensor

Conducted test confirmed the correctness of given sensitivity coefficient and appropriate preload for the desired  $F_x$  and  $F_y$  load range.

## 6. Conclusions

An example of a computer aided estimation of the tire external load state ( $\mathbf{W}$ ) by measured internal suspension reactions ( $\mathbf{R}$ ) is presented. The foregoing linear relations are described with the jacobian matrix.

The measured kinematic characteristics of strut suspension are compared to the modeled ones. Good functions matching confirms the validity of the kinetostatic model.

The designed constructional solution of sensor mounting is described along with the sensor calibration method. A benchmark of the examined and reference sensors has demonstrated satisfactory conformation of the measurement. Usability of the selected sensor has been proved on a test stand in uniaxial and complex load states.

In the context of ongoing research following actions will be completed:

- fitting of the complete measuring system into the test car,
- trials of different wheel load states on a test rig,
- conducting road tests.

## References

- [1] Góra M., Maniowski M., *Verification of 6DOF platform with wire-based sensors for spatial tracking*, The Archive of Mechanical Engineering, LVIII 2011, Number 2.
- [2] Kluziewicz M., Maniowski M., *Estimation of wheel load state by using suspension joints reactions*, *Badania Pojazdów*, praca zbiorowa pod redakcją Władysława Mitiańca, Opracowanie Monograficzne, Kraków 2014, 61-71.
- [3] Kluziewicz M., Maniowski M., *Stany nadsterowności podsterownego samochodu z przednim napędem*, *Zeszyty Naukowe Instytutu Pojazdów Politechniki Warszawskiej*, z. 1 (77), 2010, 169-177.
- [4] Knapczyk J., Gansiniec O., Maniowski M., *Charakterystyki opony samochodowej (175/70R14)*, *Teka Komisji Nauk.-Prol. Motoryzacji PAN O. Kraków*, z. 22, Kraków 2001.
- [5] Knapczyk J., Maniowski M., *Elastokinematic Modeling and Study of Five-Rod Suspension with Subframe. Mechanism and Machine Theory*, Vol. 41, 2006, 1031-1047.
- [6] Knapczyk J., Maniowski M., *Porównanie uproszczonych modeli dynamicznych opony toczącej się ze znośaniem*, *Materiały Autoprogres-Konmot*, Warszawa 2002.
- [7] Luty W., *Nieustalone stany znośnienia boczno-ogumienia kół jezdnych w symulacji ruchu krzywoliniowego pojazdu*, *Prace Naukowe Politechniki Warszawskiej*, Warszawa 2013.
- [8] Pacejka H.B., *Tyre and Vehicle Dynamics*, Butterworth-Heinemann, SAE, 2002/2006.
- [9] Prochowski L., *Mechanika ruchu. Pojazdy samochodowe*, WKŁ, 2008.
- [10] *3-Component Force Sensor Type 9047C, Instruction Manual* ([www.kistler.com](http://www.kistler.com)).