

JOANNA FABIŚ-DOMAGAŁA\*

## FMEA ANALYSIS OF POTENTIAL FAILURES OF TURBOCHARGERS FOR COMBUSTION ENGINES BY THE USE OF THE SIMILARITY METHOD

---

### ANALIZA FMEA POTENCJALNYCH WAD TURBOSPĘŻARKI SILNIKÓW SPALINOWYCH METODĄ PODOBIENSTWA

#### Abstract

This paper presents an FMEA analysis of turbochargers for combustion engines by the use of the similarity method and dependency diagrams. Typical functions of selected components of turbochargers were defined and the dependency between them identified. Potential failures that may appear during operation have also been defined. Using the principle of similarity, potential failures have been defined and classified.

*Keywords: FMEA, analysis, failure, turbocharge*

#### Streszczenie

W artykule zaprezentowano analizę przyczyn i skutków powstawania potencjalnych wad (FMEA) dla turbospężarki silnika spalinowego, stosując diagramy zależności oraz metodę podobieństwa macierzy. Dla wyróżnionych elementów turbospężarki określono ich funkcje, zidentyfikowano zależności zachodzące pomiędzy współdziałającymi elementami oraz ich potencjalne wady. Korzystając z zasady podobieństwa macierzy dokonano pogrupowania i klasyfikacji potencjalnych wad.

*Słowa kluczowe: MEA, analiza, wada, turbospężarka*

---

\* M.Sc. Joanna Fabiś-Domagala, Institute of Applied Informatics, Faculty of Mechanical Engineering, Cracow University of Technology.

### List of symbols

$c$	– component of turbocharge
$e$	– function of component
$f$	– potential failure
<b>EC</b>	– dependency diagram function – component
<b>CF</b>	– dependency diagram component – failure
<b>EF</b>	– dependency diagram function – failure
<b>CF<sup>T</sup></b>	– transposed matrix component – failure
$\lambda_{FF}$	– similarity matrix failure – failure

## 1. Introduction

Modern passenger cars are more and more often equipped with devices to increase engine power such as turbochargers, the task of which is to delivery additional air into the combustion chamber. Turbochargers were primarily used in diesel engines. The new trend called “downsizing” spread their use to also within in small gasoline engines. Turbochargers do not consume engine power because they are driven by the exhaust gas energy, on the other hand, they are exposed to very high temperatures. Therefore the proper use of a car with a turbocharger is extremely important. Inappropriate use leads to various types of damage. Turbocharger failure usually makes the engine unable to run. Hence, there is a need to look for methods of diagnosing failures and their causes at the early stages of their formation. One of the methods that allows for the early identification of the possible failures is qualitative analysis FMEA.

The paper presents failure modes and effects analysis of failures of turbochargers for combustion engines using the similarity method in the matrix FMEA.

## 2. The object of analysis

The object of the analysis is the turbocharger shown in Figure 1, where: 1 – shaft; 2 – turbine wheel; 3 – compressor wheel; 4 – body; 5 – turbine housing; 6 – compressor housing; 7 – sleeve bearing; 8 – sealing ring; 9 – screw.

The analyzed turbocharger consists of a turbine and compressor connected by a common shaft. The turbine wheel is located in the exhaust system and the compressor wheel is in the intake pipe. Due to this different working conditions, they were analyzed as two separate components (despite that they are connected to each other). In the turbocharger the following components can be identified: body; turbine housing with exhaust port; compressor housing with intake port (during analysis, these components will be considered as one component – housing). In the body, there is a system of hydrodynamic bearings, however, they perform the same function, therefore only one was investigated (filters rule was adopted). The tightness of the body is provided by a sealing system in the form of two sealing rings. The analysis of the turbocharger does not include screws as despite the fact that they present, they do not cause possible failures.

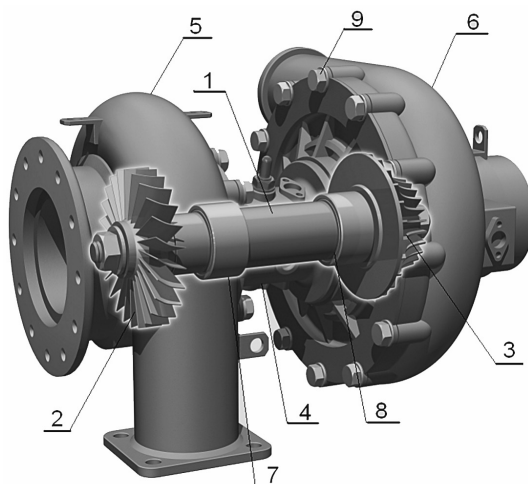

Fig. 1. Scheme of turbocharger [1]

After taking into account the above assumptions, the matrix FMEA analysis was performed for six components of the turbocharger: housing ( $c_1$ ); shaft ( $c_2$ ); turbine wheel ( $c_3$ ); compressor wheel ( $c_4$ ); sleeve bearing ( $c_5$ ); sealing ring ( $c_6$ ).

### 3. Matrix FMEA analysis

When using a matrix FMEA analysis, it is necessary to create two dependency diagrams **EC** (function – component) and **CF** (component – failure) [2]. Having built these two diagrams, matrix **EC** is multiplied by the matrix **CF**. The result of multiplication is a matrix **EF** (function – failure):

$$\mathbf{EC} \times \mathbf{CF} = \mathbf{EF} \quad (1)$$

Dependency diagram **EC** was created by assigning the analyzed components' functions, which perform in the turbocharger. Six functions were identified:

- fixing ( $e_1$ ) – maintains the position of the axis of the shaft,
- positional ( $e_2$ ) – proper layout of the turbocharger components,
- transport ( $e_3$ ) – transferring rotation of the turbine wheel into compressor wheel,
- assembly ( $e_4$ ) – assemblies' components,
- converting ( $e_5$ ) – conversion of kinetic energy of the gas into the compressor rotation, conversion of compressor rotation into energy pressure causes the rotation of the shaft,
- protecting ( $e_6$ ) – preventing oil leakage from one part to another, preventing the body against gas penetration, turbocharger seal, minimizing friction.

The relationships that occur between the analyzed components ( $c_j$ ) and functions carried out by them ( $e_i$ ) are shown in Table 1. For each components of matrix  $e_i p_j$  there was assigned a value of 0 or 1. If a pair does not perform any function than value 0 is assigned. If the function is performed, a value 1 is assigned.

Table 1

**Dependency diagram between analyzed components and their functions (EC)**

		Analyzed components					
		$c_1$	$c_2$	$c_3$	$c_4$	$c_5$	$c_6$
Functions	$e_1$	0	0	0	0	1	0
	$e_2$	1	0	0	0	0	0
	$e_3$	0	1	0	0	0	0
	$e_4$	0	1	0	0	0	0
	$e_5$	0	0	1	1	1	0
	$e_6$	0	0	0	0	1	1

In the next step of the analysis, the dependency diagram **CF** was created. Based on the identified functions, five failures ( $f$ ) were identified for six turbocharger components. These failures are: crack ( $f_1$ ); overheating ( $f_2$ ); seizure ( $f_3$ ); corrosion ( $f_4$ ); wear ( $f_5$ ). Relationships between the analyzed components ( $c_i$ ) and their potential failures ( $f_j$ ) are shown in Table 2.

Table 2

**Dependency diagram between components and their potential failures (CF)**

		Potential failures				
		$f_1$	$f_2$	$f_3$	$f_4$	$f_5$
Analyzed components	$c_1$	1	0	1	1	0
	$c_2$	1	1	0	0	1
	$c_3$	1	1	1	0	1
	$c_4$	0	0	1	0	1
	$c_5$	1	1	1	1	1
	$c_6$	0	0	0	0	1

For each relationships  $c_i f_j$ , a value of 0 or 1 was assigned according to the following rule: possible influence of failure of the component: value = 1, no influence value = 0. As it arise from diagram CF destructive factors for individual components are as follows:

- turbocharger housing: cracking due to thermal shock, seizure, corrosion,
- shaft: crack, overheating, wear,
- turbine wheel: crack (due to metal fillings or other solids which block wheels and brake vanes), overheating, seizure and wear,
- compressor wheel: seizure and wear (caused by suction of air with dust),
- bearing: crack, seizure, overheating, corrosion, wear,
- sealing ring: wear.

At the last stage of the matrix FMEA, based on diagrams **EC** and **CF**, using the principle of a matrix multiplication **EF** diagram has been built which shows the probability of failures ( $f$ ) for the analyzed elements ( $c$ ) due to the functions performed in the turbocharger ( $s$ ). Table 3 shows the probability of occurrence of failures on a scale of 0 to 3. A value of 0

in position  $ij$  denotes no effect and the value of 3 in position  $ij$  denotes the highest probability of  $j$ -th failure for the  $i$ -th function.

Table 3

**Diagram of dependency of function – potential failure (EF)**

		Potential failure				
		$f_1$	$f_2$	$f_3$	$f_4$	$f_5$
Functions	$e_1$	1	1	1	1	1
	$e_2$	1	0	1	1	0
	$e_3$	1	1	0	0	1
	$e_4$	1	1	0	0	1
	$e_5$	2	2	3	1	3
	$e_6$	1	1	1	1	2

For the analyzed turbocharger, the highest probability of defect seizure ( $f_3$ ) and wear ( $f_5$ ) is for components realizing function “converting” ( $e_5$ ). These are the turbine rotor, compressor rotor and bearing.

#### 4. Application of similarity method in FMEA matrix analysis

By using the similarity method presented in work [2] and described by equation (2), potential failures can be classified and grouped:

$$\mathbf{CF} \times \mathbf{CF} = \lambda_{\text{FF}} \quad (2)$$

Matrix  $\lambda_{\text{FF}}$  (failure – component) was obtained by multiplying the transposed matrix component – failure ( $\mathbf{CF}^T$ ) by the matrix component – failure ( $\mathbf{CF}$ ) shown in Table 2. Using equation (2), a matrix  $\lambda_{\text{FF}}$  has been built. Table 4 shows a fragment of  $\lambda$  matrix.

Table 4

**Similarity matrix failure – component ( $\lambda_{\text{FF}}$ )**

		Potential failures				
		$f_1$	$f_2$	$f_3$	$f_4$	$f_5$
Functions	$f_1$	4	3	3	2	3
	$f_2$	3	3	2	1	3
	$f_3$	3	2	4	2	3
	$f_4$	2	1	2	2	1
	$f_5$	3	3	3	1	5

In this matrix, both columns and rows show the potential failures. The value of the element  $\lambda_{ij}$  is the probability of failure. In the new created matrix, values  $\lambda_{ij}$  are

on a scale of 1 to 5. These values for  $i = j$  are the criteria for grouping potential failures into four groups:

- first group: wear ( $f_3$ ),
- group two: crack ( $f_1$ ), seizure ( $f_3$ ),
- group three: overheating ( $f_2$ ),
- group four: corrosion ( $f_4$ ).

Obtained groups of failures were classified into three levels according to the following rule:

- level I deals with groups of failures that can occur the most frequently: the first group,
- level II deals with two-elements group of failure with less probability of occurrence: the second and third groups,
- level III is assigned to failures with the lowest probability of occurrence: the fourth group.

Based on classified failures, depending on the diagram function – failure (Table 3) a set of possible failures were determined that need to be analyzed at the design stage of modification of the turbocharger. For this purpose, the rule of three steps was applied. This method in details is described in [3]. In the first step, failures of the analyzed turbocharger that should always be considered at the design stage or during modification were identified. This is: wear ( $f_3$ ), which belongs to level I. In the second step of analysis for the function converting ( $e_3$ ), identified failures have the highest probability of occurrence according to the graph of dependencies **EF**. According to this matrix for the converting functions the highest probability of occurrence is seizure ( $f_3$ ) and wear ( $f_3$ ). In the third step of the analysis levels to which belong failures were identified. If this is the level I identified failure must always be considered in the design stage of a new turbocharger or during modification. If this is the level II all failures belonging to this level should be examined at the design stage of a new turbocharger or during modification, and if it is a level III identified failure needs to be considered at the design stage. Failure wear belongs to the level I and should always be considered by the designer during designing or modification. The failure seizure belongs to level II, therefore all failures belonging to this level should be examined. These failures are: crack and overheating. Analysis of turbocharger by the use of similarity method shown that for processing function exist a set of four potential failures that the designer should consider. These failures are: crack ( $f_1$ ), overheating ( $f_2$ ), seizure ( $f_3$ ) and wear ( $f_3$ ).

## 5. Summary

This paper presents a matrix FMEA method to determine the potential failures of turbochargers. It was proposed to classify turbocharger components as the functions performed by them (EC) and possibility of failure (CF). By using the similarity method, ‘failure-failure’ failures were classified and grouped by three levels of significance. The results allowed for determining the set of failures that can be helpful for designers in improving turbocharger design and for users. The calculations in the FMEA analysis were performed using Mathcad.

## References

- [1] [www.infosamochody.pl](http://www.infosamochody.pl), *Materiały informacyjne*.
- [2] Roberts R.A., Stone R.B., Tumer Y., *Deriving function-failure similarity information for failure-free rotorcraft component design Method*, ASME Design for Manufacturing Conference, 2002.
- [3] Arunajadai S.G., Stone R.B., Tumer Y., *Failure mode identification through clustering analysis*, Quality and Reliability Engineering International Journal, vol. 20, 2004, 511-526.
- [4] Poradnik serwisowy, *Doładowanie silników spalinowych – przegląd konstrukcji i diagnostyka*, Wydawnictwo Instalator Polski, Nr 1/2007.
- [5] [www.workturbochargers.com](http://www.workturbochargers.com), *Turbo failure*.