

MACIEJ KONOPACKI*, ARTUR FRĄCKOWIAK**, PIOTR TABERO**,
KAROL FIJAŁKOWSKI***, RAFAŁ RAKOCZY*

STUDIES OF A MIXING PROCESS BY USING THE VARIOUS TYPES OF MAGNETIC PARTICLES AS ACTIVE MICRO-STIRRERS

ANALIZA PROCESU MIESZANIA Z ZASTOSOWANIEM RÓŻNEGO TYPU CZĄSTEK MAGNETYCZNYCH DZIAŁAJĄCYCH JAKO MIKRO-MIESZADŁA

Abstract

The main purpose of this report is to present the effect of various types of magnetic particles on the mixing time. The magnetic particle may be treated as a miniaturized mixer and it may offer a unique, alternative approach to mixing. The obtained results suggest, that the mixing time under the rotating magnetic field (RMF) may be worked by using the relation between the mixing time number and the modified Reynolds number.

Keywords: mixing process, mixing time, magnetic particles, magnetic field

Streszczenie

Głównym celem pracy jest przedstawienie wyników dotyczących procesu mieszania z zastosowaniem wirującego pola magnetycznego i cząstek magnetycznych. Uzyskane wyniki zostały przedstawione w formie relacji wiążącej bezwymiarowy czas mieszania i modyfikowaną liczbę Reynoldsa.

Słowa kluczowe: proces mieszania, czas mieszania, cząstki magnetyczne, pole magnetyczne

* M.Sc. Maciej Konopacki, Ph.D. D.Sc. Eng. Rafał Rakoczy, Institute of Chemical Engineering and Environmental Protection Process, West Pomeranian University of Technology, Szczecin.

** M.Sc. Artur Frąckowiak, Ph.D. D.Sc. Eng. Piotr Tabero. Department of Inorganic and Analytical Chemistry West Pomeranian University of Technology, Szczecin.

*** Ph.D. Eng. Karol Fijałkowski, Department of Immunology, Microbiology and Physiological Chemistry, West Pomeranian University of Technology, Szczecin

1. Introduction

The design, scale-up, and optimization of industrial processes conducted in agitated systems require, among other, precise knowledge of the hydrodynamics, mass- and heat-transfer processes and reaction kinetics. It should be noticed, that an agitation and mixing are basic steps in many chemical processes. A mixing process is very often occurred in the chemical engineering systems. On a macroscopic scale, the improvement of hydrodynamic conditions can be achieved by using various techniques of mixing, vibration, rotation, pulsation and oscillation in addition to other techniques, such as the use of fluidization, turbulence promotes or magnetic and electric fields, and so on.

A magnetic field (MF) is a versatile option to enhancing several physical and chemical processes [1, 2]. Static or rotating magnetic fields (RMF) might be used to augment the process intensity, instead of a mechanical mixing. One of the advantages of a RMF is the possibility to apply it to generation and control of the hydrodynamic conditions for the magnetic particle disperse systems. The use of magnetic particles as active micro-stirrers under the action of RMF has attractive applications in the various areas of the chemical engineering [3–5].

Up to the present, a lot of effort has been put in studying a mixing process in the traditional tanks stirred by standard impellers, by using the computational or experimental methods. The magnetically assisted fluidization (MAF) is widely encountered in practical applications and in manufacturing of drugs, food, chemical products, biochemistry, and many other fields of technology [6, 7].

In the case of MAF, the particle's motions inside the fluidization volume are caused to the space and time variable magnetic field driving the particles through a relatively stagnant fluid. The movement of particles may be controlled by means of the strong body magnetic forces. The MAF may be realized by using the static or alternating MFs creating interparticles forces strong enough to provoke particles flocculation. It should be noticed that a rotating magnetic field (RMF) may be considered as a significant improvement of the MAF among the dominating experimental studies in axial fields. The movement of magnetic particles excited under a RMF has improved the hydrodynamic conditions inside the fluidization vessel (lack of channels and a fluid axial dispersion). This movement may be controlled by field intensity and a field orientation [8].

The main aim of this study is to report the research results in the field of a mixing process under the action of a RMF. The possibility of using the various types of the magnetic particles (NiFe_2O_4 , MgFe_2O_4 , Fe_3O_4) as active micro-stirrers under the influence of a RMF for enhancement of a mixing process is discussed.

2. Experimental details

The investigations were performed by means of the experimental apparatus shown in Fig. 1. The rotating magnetic field has been generated by averages of the modified 3-phase stator of an induction squirrel cage motor whose parameters are compatible with Polish Standard PN-63/E-08107. In the case of these investigations, the stator has been supplied

with 50 Hz three-phase alternating current. The AC multifunctional transistorized inverter has been used to change the frequency of the rotating magnetic field. In the experimental procedure, this frequency has been varied in the range between 1 and 50 Hz.

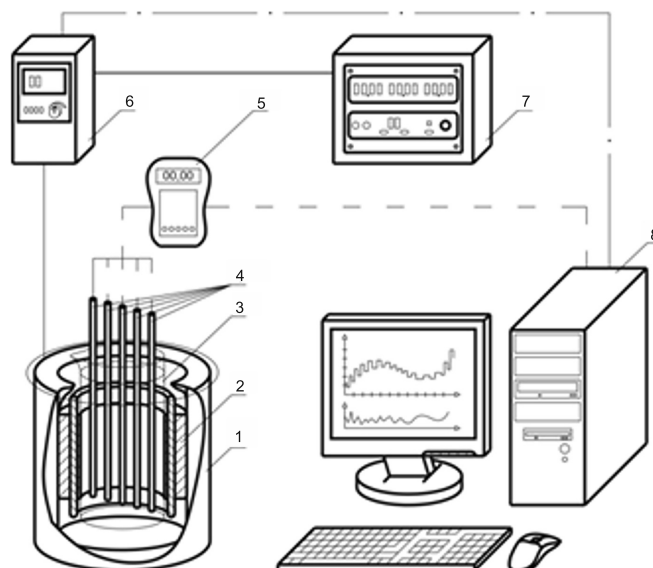

Fig. 1. Experimental set-up: 1 – cooling jacket, 2 – RMF generator, 3 – cylindrical glass vessel, 4 – microprocessor magnetic field sensors, 5 – Hall probe, 6 – AC transistorized inverter, 7 – electronic control box, 8 – personal computer

A liquid-filled glass container was placed inside the stator. The clearance between the side of glass container and the grooves of stator is equal about to 0.001 m. From the preliminary tests of the experimental apparatus was affirmed, that the empty glass container placed inside the stator not influenced on the working parameters of the RMF generator. In the case of these experimental measurements the RMF is generated by coils located around the cylinder, and the axes are directed along the radius. When the alternating current supplies the windings, the generated magnetic field rotates about the cylinder axis with the constant angular frequency.

The RMF is identified by using the magnetic induction. The values of this magnetic field parameter at different points inside the glass container are detected by using the Hall probe connected with the personal computer and controlled by means of the AC (alternating current) frequency, f , equaled to the frequency of RMF. On the basis of the experimental measurements, the maximal values of the magnetic induction, B_{\max} , have been obtained. The graphical form of this relation is given in Fig. 2.

In the case of the present study, the magnetic particles (NiFe_2O_4 , MgFe_2O_4 , Fe_3O_4) are fed into the working volume and suspended by means of the RMF. Moreover, the state of the magnetic suspension may be achieved during the mixing process. The RMF changes the structure of the disperse system and generates eddies or micro-vortices in the surrounding

liquids. It is well-known that the magnetic particles could form chains along the field lines and rotate with the external RMF in the liquid–magnetic particles mixture. In addition, these particles may be treated as small agitators, involving the unsteady rotational movement of the mixing volume.

The following reactants were used for the syntheses of NiFe_2O_4 and MgFe_2O_4 : Fe_2O_3 (p.a. Apolda, Germany), $\text{C}_2\text{H}_6\text{Ni}_5\text{O}_{12} \cdot 4 \text{H}_2\text{O}$ (p.a., Aldrich, Germany) and $\text{MgCO}_3 \cdot \text{Mg}(\text{OH})_2 \cdot 3\text{H}_2\text{O}$ (p.a., POCh, Poland). The reagents weighed in stoichiometric proportions were ground in an automatic agate mortar (3×15 min) and sintered in air at 1100°C for 3h and next gradually cooled to room temperature. The phase composition of phases was checked using XRD method (HZG-4 diffractometer, Germany, $\text{Co}_{\text{K}\alpha}$ /Fe radiation).

There are two broad methods of perpetrating Fe_3O_4 particles – size reduction and precipitation, i.e., making little particles out of big ones and producing little ones from solution initially. It is a remarkable fact that size reduction by grinding can succeed in reducing bulk material to the required size.

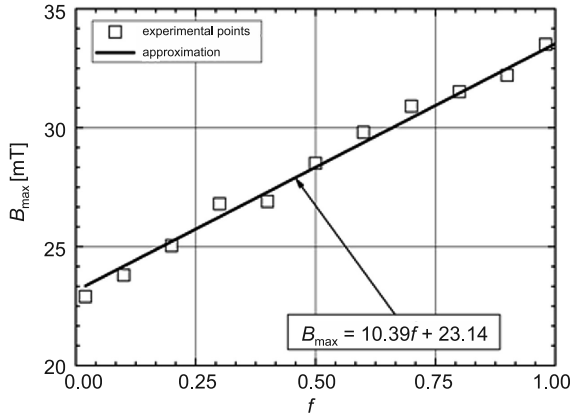

Fig. 2. The graphical presentation of the relation between the maximal value of magnetic induction and the normalized value of RMF frequency ($f = f/f_{\text{max}}$; $f = f/50$)

All experimental measurements were initiated by loading into a glass container the magnetic particles with the histograms presented in Fig. 3. It should be noticed that the longitudinal dimensions of these particles can be described by the log-normal functions:

$$w(l) = \frac{a}{l} \exp \left[-0.5 \left(\frac{\ln(l(x_0)^{-1})}{b} \right)^2 \right] \quad (1)$$

where:

a, b, x_0 – parameters;

l – characteristic measurement of particle [mm].

Under the action of RMF, the magnetic particles are lifted and the disperse system behavior by increasing the MF intensity maybe observed. At the initial state of process

production of disperse systems, the fraction of magnetic particles was put into a glass container with dispersing liquid, where the fraction was suspended by means of RMF. The experimental results show that the movement of ferromagnetic particles may be controlled by the magnetic, gravity and resisting force. In suspension of magnetic particles, the production efficiency of disperse systems is strongly depended on the values of magnetic induction. This parameter plays an important role in ensuring the optimal hydro-mechanical properties of the suspension. Too small values of magnetic induction have an unsatisfactory ability of the suspended all magnetic particles in liquid phase and may only raise very small magnetic particles. When the gravity and ferromagnetic force are equal, the magnetic particles with the very small mass may be remained in the liquid phase, but the another particles with the much more mass are attracted by the gravity force toward flask bottom. The part of particles may be leaved the dispersed state and fallen on the bottom of the glass container.

From the practical point of view, the magnetic particle systems may be described by using the mean diameter. The values of these diameters for the analyzed case are equal to: $d_{\text{NiFe}_2\text{O}_4} = 0.75 \text{ mm}$; $d_{\text{MgFe}_2\text{O}_4} = 0.86 \text{ mm}$; $d_{\text{Fe}_3\text{O}_4} = 0.8 \text{ mm}$.

The mixing time is the time measured from the instant of tracer injection, until the vessel contents have reached a specified degree of uniformity, when the system is said to be mixed.

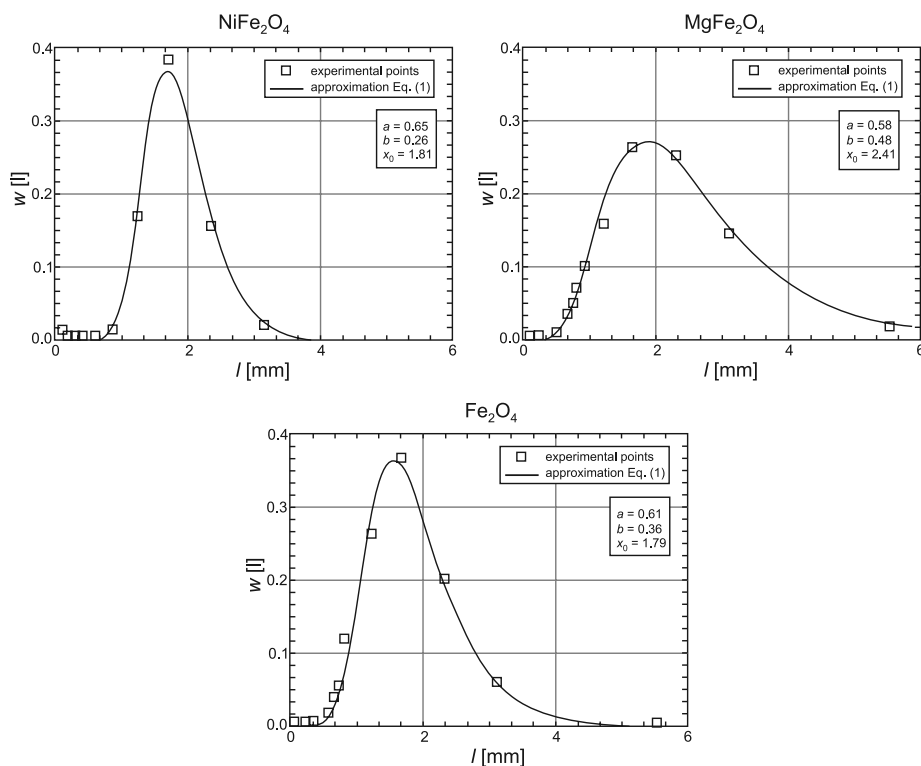

Fig. 3. The distribution of magnetic particles for initial state

In experiments, mixing time is often estimated by means of a tracer technique. In general, the tracer concentration at a point within the mixed vessel varies with the time and the time taken for the variation to reduce below a certain level is taken as the mixing time. In the case of these experimental results, the mixing time was measured in the computer-aided experimental set-up. Tracer experiments, used to determine mixing time, were conducted by means of the chemical-response technique. A total of 3300 ml distilled water was introduced into the glass container. As tracer, 250 ml of sodium hydroxide solution (0.1 mol dm^{-3}) were

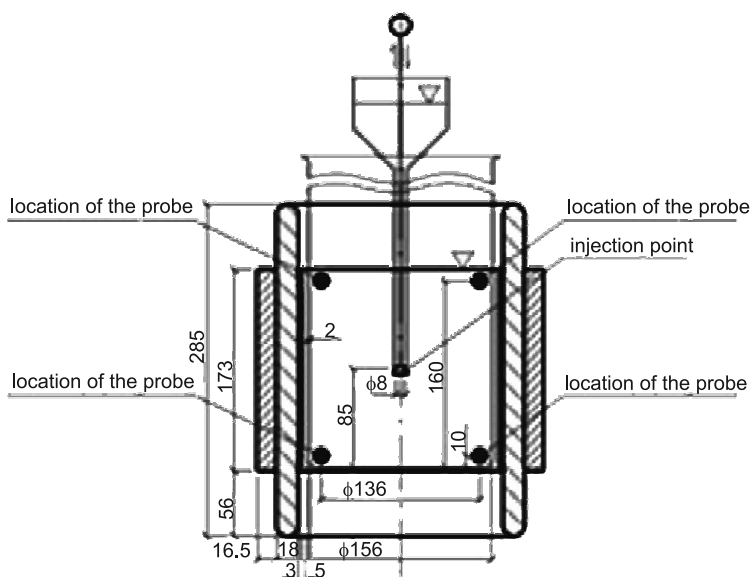

Fig. 4. Localization of probes and injection point

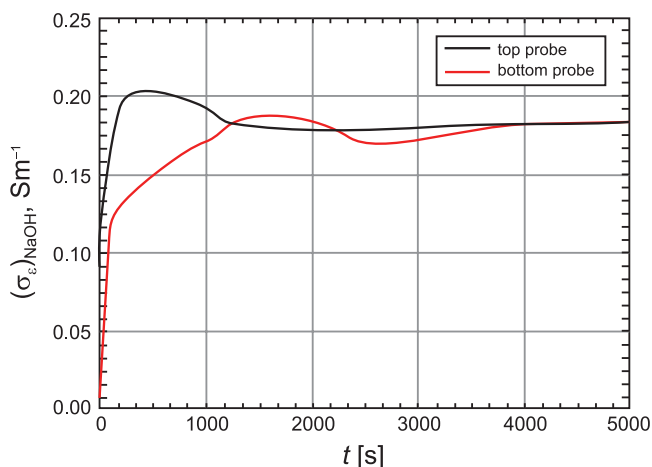

Fig. 5. The typical example of conductivity changes during the mixing time investigations

injected. Conductivity was measured as a function of time by means of the conductivity electrodes and the multifunction computer meter CyberScan PCD 6500 Eutech. Voltage signals were registered digitally every 0.1 s. The localization of the probes and injection point are presented in Fig. 4. The mixing process was regarded as a complete, when the average conductivity within the liquid did not change with time. In this work, this point is reached when the change in conductivity remains smaller than 3% of the overall increase of conductivity. The typical evolution of the conductivity during experiments is shown in Fig. 5.

3. Results and discussion

In the present investigations, the dimensionless mixing time for the tested RMF mixing process is defined as follows:

$$\Theta = \frac{\tau_{\text{mix}} \nu}{D^2} \quad (2)$$

where:

- τ_{mix} – mixing time [s],
- ν – kinematic viscosity [$\text{m}^2 \cdot \text{s}^{-1}$],
- D – diameter of glass container [m].

It is decided, that in the present report the hydrodynamic conditions under the action of RMF may be expressed as follows:

$$\text{Re}_\omega = \frac{\omega D^2}{\nu} \quad (3)$$

where:

- ω – angular velocity of rotating magnetic field [s^{-1}].

According to the proposed dimensionless numbers, the plot of the data obtained in this work for the water without the magnetic particles is presented in Fig. 6.

The results given in Fig. 6 indicate a reduction in the mixing time number with the increase in the Reynolds number. These experimental results in Fig. 6 suggest that the obtained results may be analytically described by a unique monotonic function:

$$\Theta = a(\text{Re})^b \quad (4)$$

The constant and the exponent are computed employing the Matlab software and the principle of least squares.

The generalization of the experimental results of the mixing time under the action of the magnetic particles may be correlated by using the general relationship (4). The results of our experiments suggest, that the Reynolds number for the magnetic particles may be given by means of the following relation:

$$\text{Re} = \frac{\omega (d_p)^2}{\nu} \quad (5)$$

where:

d_p – mean diameter for magnetic particles [m].

The effect of the various types of magnetic particles on the mixing process is evolved by showing the values Θ against Re in Fig. 7.

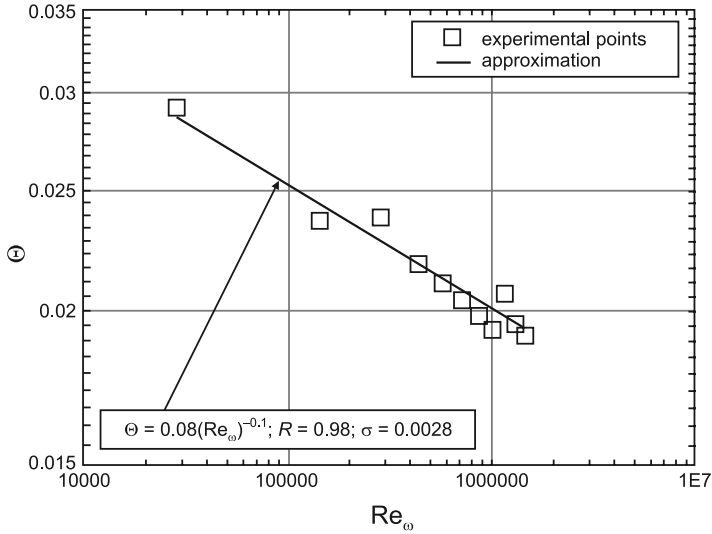

Fig. 6. The dependence $\Theta = f(Re)$ for the mixing process under the action of RMF without magnetic particles

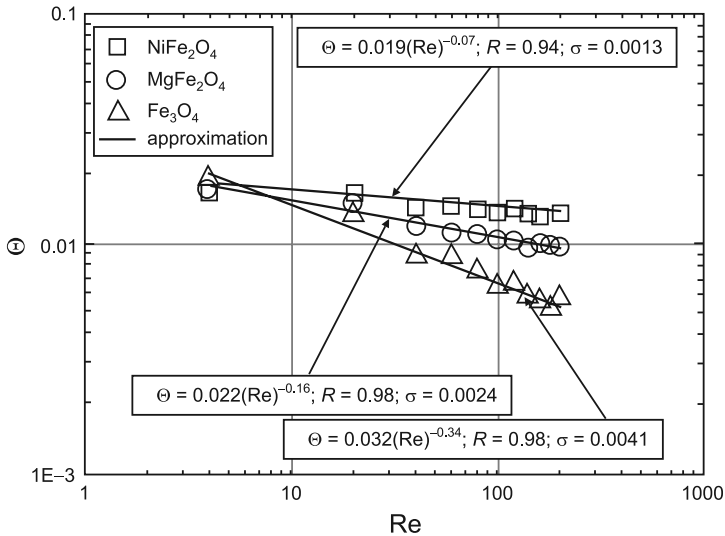

Fig. 7. The dependence $\Theta = f(Re)$ for the mixing process under the action of RMF with the various types of magnetic particles

Fig. 7 demonstrates, that within the scatter limits among the plotted data represented by the points, the dimensionless mixing time numbers decreases with the increase of the Reynolds number. It was found that as the intensity of the magnetic field increases, the time duration of the mixing process under the action of the RMF decreases.

Fig. 7 show a strong influence of the magnetic particles on the mixing process under the action of the RMF. The passive or active mixing may be used in order to enhance the fluid mixing process [9]. This active mixing, based on chaotic advection, is usually achieved by means of the periodic perturbation of the flow fields and this way of mixing can be activated on-demand. The chaotic mixing may be realized by using the magnetic particles under the action of RMF. The magnetic particle maybe treated as a miniaturized mixer and it may offer a unique alternative approach to mixing. It should be noticed, that this mixing method may work better for channel mixing but not for mixing in vessel or reaction chamber. The power input in this mixing system may be much larger than the power consumption for the classic stirred tanks. However, on advantage of such mixing method lies in the fact that, this mixing system can be used for wide variety of fluids. Moreover, the rate of fluid mixing can be enhanced and the mixing at the micro-scale may be improved.

4. Conclusions

The objective of this paper was to determine the mixing time for the mixing system consisting of a RMF generator and magnetic particles. The RMF and the magnetic particles have different influence on this process. For the RMF, the dimensionless mixing time number decreases with the increase in the magnetic field intensity. Improvements in the mixing process may be realized by considering the synergic effect of the RMF and the magnetic particles. It should be noticed that the further experimental and theoretical studies are needed to optimize the effects of the RMF on the mixing process as well as understand the mechanism of its enhancement.

This work was supported by the Polish Ministry of Science and Higher Education from sources for science in the years 2012-2015 under Inventus Plus project.

References

- [1] Rakoczy R., Masiuk S., *Influence of transverse rotating magnetic field on enhancement of solid dissolution process*, AIChE J., vol. 56, 1416-1433.
- [2] Rakoczy R., *Enhancement of solid dissolution process under the influence of rotating magnetic field*, Chem. Eng. Process: Process Intensif., vol. 49, 42-50.
- [3] Abbasov T., Yildiz Z., Sarimeseli, A., *An experimental study on impacts of some process parameters on the electromagnetic filtration performance*, International Review of Chemical Engineering, vol. 2, 2010, 289-292.
- [4] Fraňa K., Stiller J., Grundmann R., *Transitional and turbulent flows driven by a rotating magnetic field*, Magnetohydrodynamics, vol. 42, 2006, 187-197.

- [5] Hristov J., *Simple bed expansion correlation for magnetically assisted gas-fluidized tapered beds*, International Review of Chemical Engineering, vol. 1, 2009, 316-323.
- [6] Saxena C., Ganzha V.L., Rahman S.H., Dolidovich A.F., *Heat Transfer and Relevant Characteristics of Magnetofluidized Beds*, Advances in Heat Transfer, vol. 25., Academic Press, New York 1994.
- [7] Hristov J.Y., *Fluidization of ferromagnetic particles in a magnetic field. Part2: field effects on preliminary gas fluidized beds*, Powder Technology, vol. 97, 1998, 35-44.
- [8] Hao Z., Zhu Q., Lei Z., Li H., *CH₄-CO₂ reforming over Ni/Al₂O₃ aerogel catalysts in a fluidized bed reactor*, Powder Technology, vol. 182, 2008, 474-479.
- [9] Lu L., Ryu K., Liu C., *A magnetic microstirrer and array for microfluidic mixing*, Journal of Microelectromechanical Systems, vol. 11, 2002, 462-469.