

KATARZYNA NOWAK, ANNA ZASTAWNA-RUMIN*

EXAMINATION OF A WALL BARRIER CONTAINING PHASE CHANGE MATERIAL IN A CLIMATE CHAMBER

BADANIE PRZEGRODY ZAWIERAJĄCEJ MATERIAŁ FAZOWO-ZMIENNY W KOMORZE KLIMATYCZNEJ

Abstract

This paper presents the results of the experimental tests of components containing alternating phase material. The measurements of a light frame wall, in two options: plate with internal drywall filling and plate containing phase variable material, were conducted in a climatic chamber. The temperature and heat flux density distribution on the surface of plates for non-stationary temperature conditions in a climatic chamber were analyzed. The research stand simulated the conditions where the cladding plates were heated with the increase of internal air temperature rather than through direct heating. The main goal of the experiment was to check the utility of the test procedure and the measurement equipment to the planned research of building components containing PCM.

Keywords: phase change material, PCM, heat capacity

Streszczenie

W artykule przedstawiono wyniki badań eksperymentalnych przegrody zawierającej warstwę z dodatkiem materiału fazowo-zmiennego. Badania wykonano w komorze klimatycznej dla lekkiej ściany szkieletowej w dwóch wariantach: z okładziną wewnętrzną wykonaną z płyty gipsowo-kartonowej oraz płyty zawierającej materiał fazowo zmienny. Przeprowadzono pomiary przebiegu temperatury oraz rozkładu gęstości strumieni ciepłych na powierzchniach płyt dla niestacjonarnych warunków panujących w komorze klimatycznej. Przygotowano stanowisko badawcze, w którym nagrzewanie płyt okładzinowych następowało poprzez wzrost temperatury powietrza w pomieszczeniu a nie poprzez ich bezpośrednie nagrzewanie. Za główny cel eksperymentu przyjęto sprawdzenie przydatności procedury badania oraz użytej aparatury do planowanych badań elementów budowlanych zawierających PCM.

Słowa kluczowe: pojemność cieplna, PCM, pojemność cieplna, akumulacja ciepła

* Ph.D. Katarzyna Nowak, M.Sc. Anna Zastawna-Rumin, Institute of Building Materials and Structures, Faculty of Civil Engineering, Cracow University of Technology.

1. Introduction

One of the not too many disadvantages of a light-frame construction is a problem with too low heat stability of wall barriers. Its capacity results in deficiency of heat stability that causes seasonal overheating of a building and large temperature oscillations of internal air during temperature changes of external air. It influences thermal comfort and determines the destination of a building. Overheating of a building results from solar radiation passing through glass surfaces to wall barrier surfaces inside a building. Absorption and accumulation of shortwave radiation and then secondary emission of longwave radiation takes place on wall barrier surfaces. The processes cause increase of surface temperature of wall barriers and significant increase of air temperature in a building. The consequence of the processes is the increase of so called “operative temperature” in premises that have adverse effects on thermal comfort. The referenced reasons prove the significance of the heat capacity of wall barriers. The idea of using phase change materials to increase heat capacity of materials is built on the energy saving process such as latent heat of phase change. Accumulation or emission of large amount of heat occurs during phase transition and is accompanied with a small temperature change of a specific PCM. The aim of PCM application in building components is to significantly increase the heat capacity of a building without changing its low construction weight.

2. The aim

The object of investigation is a wall barrier containing a phase change material layer. The aim is to determine the usefulness of the examination procedure and applied apparatus for evaluating the influence of PCM on thermal parameters of an internal microclimate. The study was a validation test confirming the efficiency of the applied examination procedure necessary for further studies on PCM.

3. Description of a measuring position

A measuring position was built in units of chambers. It consisted of two chambers (called: hot and cold chambers) connected by the investigated wall barrier (Ill. 1). The chambers were equipped with heating, cooling and ventilation units with automatic controls which allowed to keep specific temperatures in both chambers. There was also a possibility to control and regulate heat and humidity changes according to scheme.

The investigated wall barrier was made of a light structure and consisted of a wooden grid filled with a 15 cm layer of mineral wool. The finishing layer situated in a hot chamber consisted of a plaster board. There were also two 1 m² boards fixed abreast to a finishing layer: an ordinary plaster board and a board with the addition of phase change material, BASF brand – SmartBoard 26 (Ill. 2). Organic material used in the PCM board was Micronal; its melting point equals 26°C and a heat of phase transition equals 110 kJ/kg (according to manufacturer data). 30% of the board mass fraction consisted of PCM. Both boards had similar densities and thermal conductivities. Parallel board placement ensured identical external conditions during measurements and allowed direct comparison of the measured parameters.

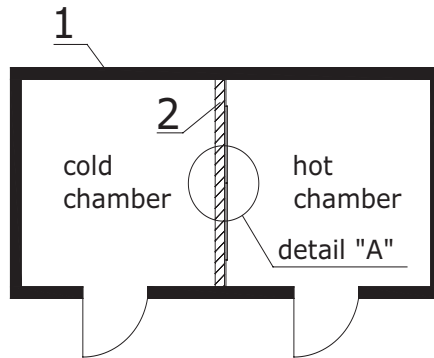

Ill. 1. Scheme of climate chambers: 1 – chamber envelope with 15 cm of polyurethane 2 – test component

detail "A"

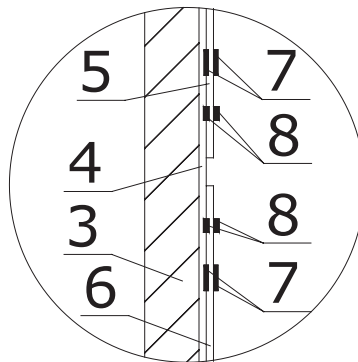

Ill. 2. Detail of the test (building component): 3 – light wood frame component filled with 15 cm of mineral wool, 4 – plaster – cardboard, 5 – plaster – cardboard, 6 – plaster – cardboard with the addition of PCM (SmartBoard 26), 7 – heat meters, 8 – transmitters Pt – 1000

4. Measurement equipment

Temperature and heat flux were the parameters measured both at the surface and between layers of a wall barrier. 4 sensors Pt 1000 and 2 heat meters (The first one round with a radius of 33 cm and the second one rectangular with dimensions of 120 cm × 120 cm) were placed at the surface of each board (Ill. 3, 4). Four temperature sensors Pt 1000 and one circular heat meter were also placed below the surface of each board (Ill. 5, 6). Air temperature inside the chambers was measured by temperature sensors Pt 100 and Pt 1000. Measured parameters were recorded by a data collecting system: Ahlborn Almejo and connected with a computer. All measurement data were collected using system Data-Control 4.2. Further calculations were conducted on Microsoft Excel.

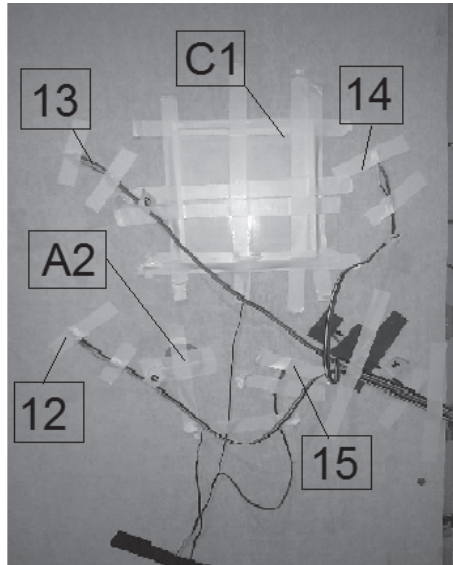

III. 3. Picture of the plate with sensors attached at the surface. 12, 13, 14, 15 – Pt 1000 temperature sensors, A2 – circular heat meter 33 mm dia, C1 – square heat meter 120 × 120 mm

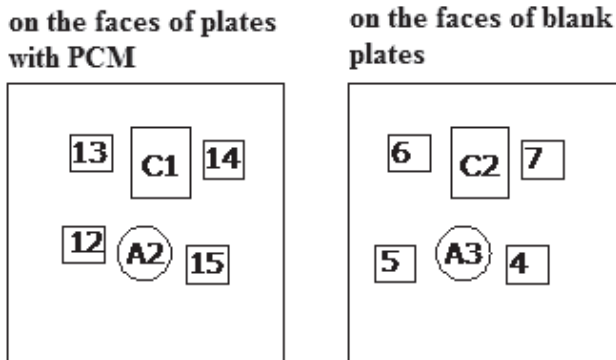

III. 4. Location of sensors on the plate surface. 4, 5, 6, 7, 12, 13, 14, 15 – Pt 1000 temperature sensors, A2, A3 – circular heat meter 33mm dia, C1, C2 – square heat meter 120 × 120 mm

5. Study in a climate chamber

The article presents the results of one out of three study stages. The study was conducted in 24-hour cycles allowing examination of real temperature changes in sunny premises. Steady operating conditions were kept in a hot chamber during a whole cycle of examination. Air temperature was constant and equal to 18°C. In a cold chamber, temperature varied cyclically. There was an increase of air temperature from 18°C to 36°C and then a decrease to

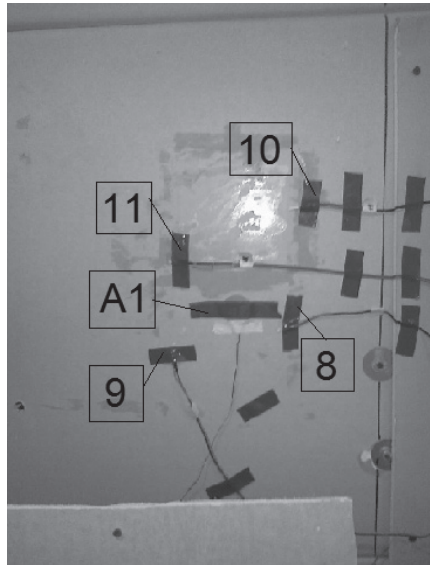

III. 5. Picture of the PCM plates with sensors located below the plate surface. 8, 9, 10, 11 – Pt 1000 temperature sensors, A1 – circular heat meter 33 mm dia

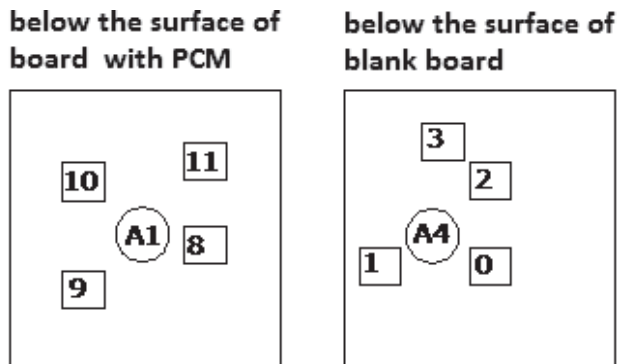

III. 6. Placement of sensors below the plates' surface. 0, 1, 2, 3, 8, 9, 10, 11 – Pt 1000 temperature sensors, A1, A4 – circular heat meter 33 mm dia

starting values during 12 hours. Both plaster boards underwent the same operating conditions during measurements.

This study stage was to observe the temperature changes on the surfaces of front and back boards in a situation when on one side of a wall barrier the temperature varies. This article presents the results of a study stage with a temperature observed during sunny days of springtime in our climate.

Air temperature in a chamber increased 6 degrees every hour because of the technical capacity of the control equipment. The rate of temperature change was not constant; it

changed according to the scheme presented in Ill. 7. The scheme presents three repeated cycles of temperature distribution.

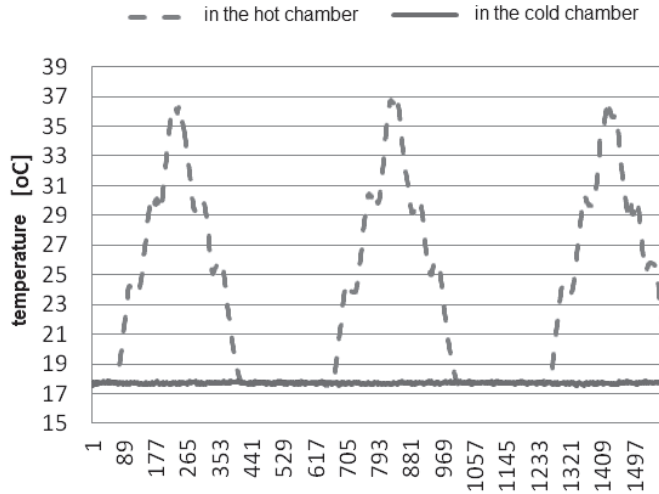

Ill. 7. Measurement of the air temperature distribution in the hot and cold chamber during testing

The difference between internal air temperature and temperature of finishing surfaces is the information on the significant value of thermal comfort from the premises point of view. The chart presented in Ill. 8, allows to observe temperature changes that occurred on front board surfaces of an ordinary plaster board and a board with the addition of phase change

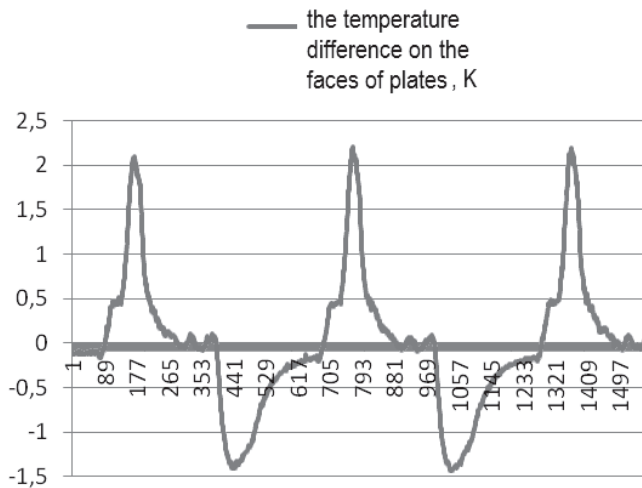

Ill. 8. Measurement of the temperature difference on the faces of blank plates and plates with PCM

material. During the process of air temperature increase, the temperature on the surface of a board containing PCM was lower max. 2.2°C than on the surface of an ordinary board. Such advantageous temperature change of a board containing PCM results from the higher possibility of heat excess accumulation in the material. During the study the results were recorded every 2 minutes (see charts presented in the article).

There are few significant relations observed after the analysis of temperature distribution on both board' surfaces depending on air temperature changes (Ill. 9). When surrounding temperature increases, advantageous influence of PCM with a delay in increase of surface temperature can be observed in the air temperature range between 22°C to 30°C . When the air temperature exceeds 30°C , surface temperature on both boards equalises. It results from the phase change temperature of Micronal which equaled 26°C .

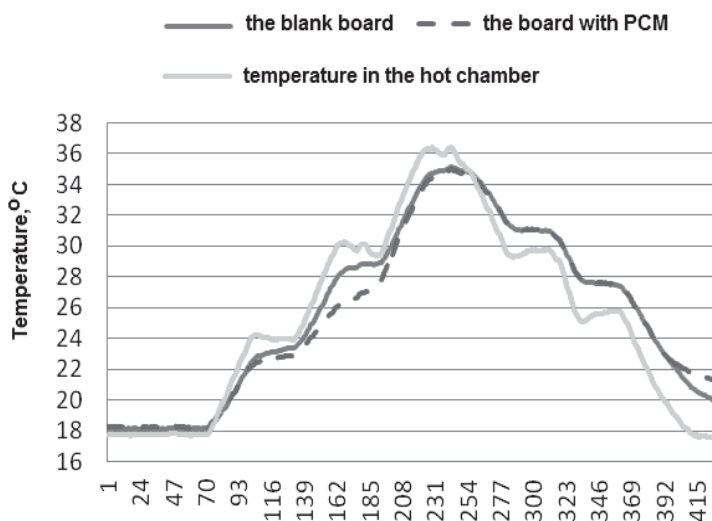

Ill. 9. Measurement of the air temperature distribution in the hot chamber and temperature measurement on the front surface of tested boards

Important aspects related to the possibility of energy storing in a PCM was a measure of temperature difference that occurred in a specific moment between front and back surfaces of both types of boards.

It can be observed that during an air temperature heating cycle in a chamber, the value of surface temperature behind a board with PCM is lower than behind an ordinary board. It results from the absorption of thermal flux by a phase change material and much slower rate of reaching the surface of a back board.

Ill. 11 presents the change in density of thermal flux absorbed and emitted on the front surfaces of both boards. The chart presents explicitly much higher heat absorption for a board containing PCM. The results of integration of thermal flux density for examined conditions absorbed by both types of boards in studied time intervals indicate 45% higher possibility of heat accumulation by a board with PCM.

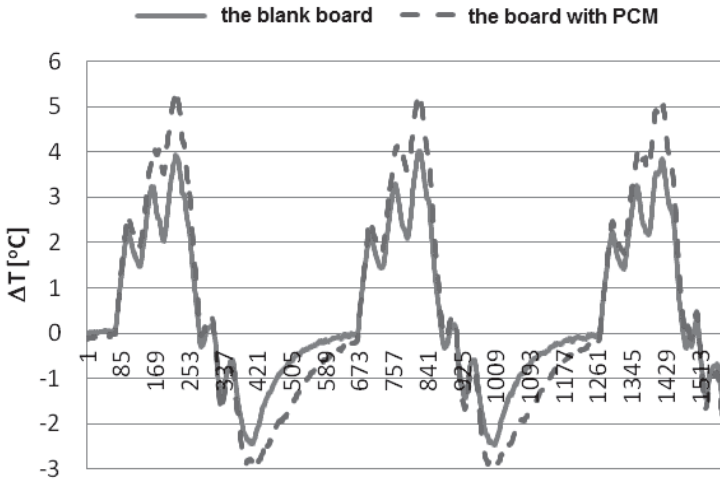

III. 10. Temperature differences between the values on the face and back of both tested boards

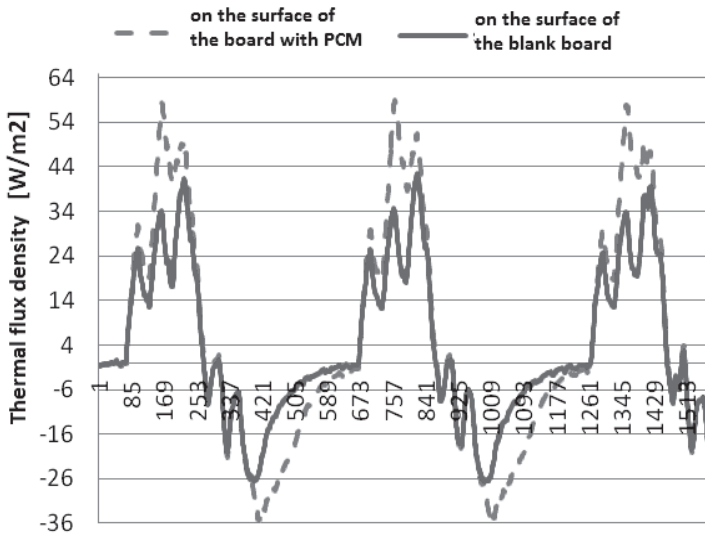

III. 11. Thermal flux density measurement of the end faces of gypsum boards

Thermal conductivity was examined for both plaster boards used in the study. Obtained λ values for both materials were comparable [6]. Differences in density of materials and their thickness can be considered as insignificantly small. From the results presented in the article, it can be concluded with some certainty that the temperature differences and density of thermal flux differences between a board containing PCM and an ordinary plaster board result only from accumulative properties of phase change material and not from differences between thermal flux passing through the boards.

6. Results

Obtained results of integration of thermal flux density for examined conditions absorbed by both types of boards in studied time intervals indicate a 45% higher possibility of heat accumulation by a board with PCM. It demonstrates the possibility of an increase of thermal capacity of the premises simultaneously with the application of the same amount of finishing material, but with the addition of PCM. Obtaining higher thermal capacity involves a decrease of maximal temperature on a wall barrier surface and also involves higher costs due to actual material prices.

In the case of directly insulated wall barriers, the efficiency of the applied material will be higher. Such an effect will result from the increase of heat exchange in the form of radiation. A solution of such type can change the thermal characteristics of a premises in a significant and advantageous manner (in the case of light structure buildings).

References

- [1] Wnuk R., Jaworski M., *Badania charakterystyk cieplnych elementów budowlanych akumulujących ciepło zawierających materiały PCM (Phase Change Materials)*, Polska Energetyka Słoneczna 2, 4/2010, 1/2011, 5-11.
- [2] Wnuk R., *Magazynowanie ciepła, pozyskanego z energii promieniowania słonecznego, z wykorzystaniem materiałów fazowo-zmiennych, w budownictwie*, II Konferencja SOLINA 2008, Innowacyjne Rozwiązania Materiały i Technologie dla Budownictwa.
- [3] Soares N., Costab J.J., Gasparb A.R., Santosc P., *Review of passive PCM latent heat thermal energy storage systems towards buildings' energy efficiency*, Energy and Buildings 59, 2013, 82-103.
- [4] Wnuk R., *Bilans energetyczny pomieszczenia ze strukturalnym, funkcjonującym w cyklu dobowym, magazynem ciepła z materiałem fazowo-zmiennym*, Czasopismo Techniczne, 1-B/2009, 269-277.
- [5] Berrouga F., Lakhala E.K., Omania M. El, Faraji M., Qarniac H. El, *Thermal performance of a greenhouse with a phase change material north wall*, Energy and Buildings 43, 2011, 3027-3035.
- [6] Nowak K., Zastawna-Rumin A., *Badanie i analiza przegrody z dodatkiem materiałów fazowo-zmiennych w warunkach niestacjonarnych*, Fizyka Budowli w Teorii i Praktyce, 2013, 291-296.