

MAREK ZOZULÁK*

COMPARISON OF DETAILED AND SIMPLIFIED WINDOW FRAME MODELLING IN TERMS OF INFLUENCE ON SURFACE TEMPERATURE

PORÓWNANIE MODELOWANIA SZCZEGÓŁOWEGO I UPROSZCZONEGO RAMY OKIENNEJ NA WARUNKACH WPLYWU NA TEMPERATURY POWIERZCHNI

Abstract

Window frame profile modeling methodology is varied. Simplified and detailed models were considered and results from transient calculation of surface temperature were compared. As is shown, the detailed window frame profile modelling has the influence and whether it is useful or not depends on purpose of modelling.

Keywords: window frame profile, simplified profile, frame cavities, mathematical model, numerical analysis, surface temperature

Streszczenie

Metodologia modelowania profilu ramy okna jest zróżnicowana. Uproszczone i szczegółowe modele zostały przedstawione. Porównano wyniki z obliczeń w warunkach nieustalonych temperatury powierzchni. Jak pokazano, szczegółowe modelowanie profilu ramy okna ma wpływ na wyniki, a to, czy warto go stosować zależy od celu modelowania.

Słowa kluczowe: profil ramy okiennej, uproszczony profil, model matematyczny, analiza numeryczna, temperatura powierzchni

* Eng. Marek Zozulák, Institute of Architectural Engineering, Civil Engineering Faculty, Technical University of Kosice, Slovakia.

1. Introduction

The subject of the transient numerical analysis is a construction detail of a window and a brick wall connection in a window sill. The selection of details is determined by their inhomogeneity – changing material properties and geometry of this place. The considered construction is a fragment of an envelope of the outdoor experimental chamber for in situ measurement. The objective is the results comparison of temperature in construction gained by transient numerical calculation with different methodology of window frame modelling – simplified and detailed frame. The influence of geometric and emissivity properties of air cavities on the overall thermal performance of aluminium frames for windows was investigated by Asdrubali et al. [1]. The use of dynamic boundary conditions and transient calculation tools is reasonable and mentioned in many cases, for example Bagoña, 2011 [2].

2. Theoretical analysis

1.1. Physical analysis of an air cavity – detailed model

The process that determines heat transfer through an air cavity includes both natural convection and radiation. It is influenced by the geometry of the cavity, its position (vertical, horizontal or inclined), the solid surfaces emissivities, and the thermophysical properties of the gas: density, thermal conductivity, specific heat capacity, thermal expansion coefficient and dynamic viscosity [1]. Thus, a simplification is needed. It is useful to introduce an equivalent conductivity of the cavity, so treating the cavity as a solid component with above thermophysical properties calculated in.

The calculation of the equivalent thermal conductivity of unventilated air cavity is based on the European standards EN ISO 10077-2 and EN ISO 6946. The calculation is based on characteristic rectangular dimensions of air cavity. The depth is parallel to the heat flow direction and the width is perpendicular to the heat flow direction (Fig. 1), (1).

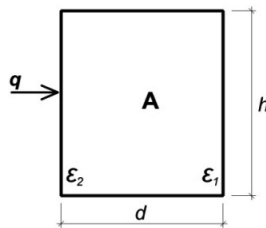

Fig. 1. Characteristic dimensions of air cavity

$$\lambda_{eq} = \frac{d}{R} = (h_c + h_r) \cdot d \quad (1)$$

where:

- h_c – convective heat transfer coefficient ($\text{W}/\text{m}^2 \cdot \text{K}$),
- h_r – radiation heat transfer coefficient ($\text{W}/\text{m}^2 \cdot \text{K}$),

- d – cavity dept (m);
 R – Thermal resistance of the cavity ($\text{m}^2\cdot\text{K}/\text{W}$).

1.2. Simplification of window frame – simplified model

According to the aim of the comparison, we also use the window frame without air cavities. If a simplified analysis is present, the entire frame is a solid component, represented by equivalent thermal conductivity gained from thermal transmittance of window frame profile construction. Plastic material specific heat capacity and density are considered in this case.

$$U_f = \frac{1}{R_{si} + R + R_{se}} \rightarrow \lambda_{eq} = \frac{d}{R} \quad (4)$$

where:

- R – Thermal resistance ($\text{m}^2\cdot\text{K}/\text{W}$),
 $R_{si/se}$ – Surface heat transfer resistances ($\text{m}^2\cdot\text{K}/\text{W}$),
 U_f – Thermal transmittance of a frame system ($\text{W}/\text{m}^2\cdot\text{K}$),
 d – Thickness of the window component (glass or frame system) (m).

3. Methodology

3.1. Window sill

Four places (Fig. 2) in the position of a window sill are solved. There is a heat flow deformation and thus, a decrease of inside surface temperature in detail of a window sill. For results analysis, two places in a nook of the brick wall and bottom window frame profile connection and two places in glass system inner surface (Fig. 2) were chosen. The results obtained by the detailed and the simplified (without air cavities – frame is a solid component) model are compared, with the aim of quantifying the differences.

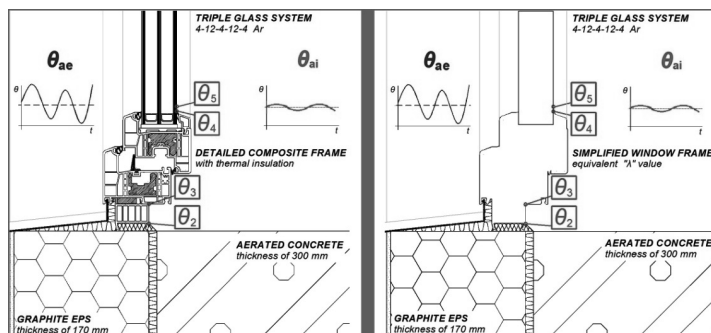

Fig. 2. Solved places in window sill of brick wall construction of the experimental chamber. Left-detailed frame model. Right – simplified frame model, without cavities of frame

3.2. Construction

It is a fragment of the building envelope construction of the experimental chamber wall. Composition of the brick wall construction is presented in Table 1 and Fig. 2. Computed thermal transmittance of the opaque wall parts is $U = 0.12 \text{ W/m}^2\text{K}$ [3].

Table 1

List of basic material characteristics. Composition of the construction (from interior)

	Layer definition	d [m]	λ_D [W/mK]	C [J/kgK]	ρ [kg/m ³]
1	Autoclaved Aerated Concrete P2-350	0.300	0.104	900.0	350.0
2	Adhesive PUR foam	0.010	0.040	800.0	35.0
3	Graphite Styrofoam	0.170	0.033	920.0	16.0
4	Adhesive mortar	0.002	0.850	900.0	1300.0
5	Primer	–	–	–	1000.0
6	Silicone plaster	0.002	0.700	900.0	1700.0

The window frames construction made by plastic composite material without frame reinforcement ($U_f = 0.9 \text{ W/m}^2\cdot\text{K}$). Triple glass system of 4-16-4-16-4 Ar ($U_g = 0.5 \text{ W/m}^2\cdot\text{K}$) is applied.

4. Numerical analysis

The numerical calculation of transient two dimensional thermal field of window sill detail is realized to solve the temperature results of the points (θ_2 , θ_3 , θ_4 and θ_5 – Fig. 2). As the boundary conditions measured local climate and indoor data, the indoor air temperature and the outdoor air temperature (Fig. 3) are used. For the results' analysis a 7 day winter period in one week of January 2013 (01.01–08.01.2013) is chosen.

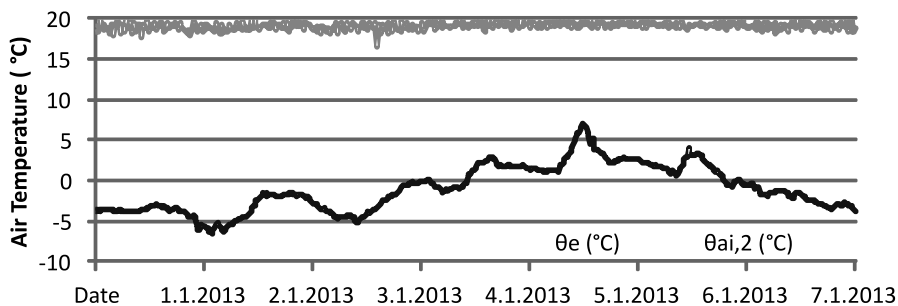

Fig. 3. Boundary temperature conditions

Transient 2D calculation is performed by Physibel software, module BISTRA. The energy balance method is used to set up a system of linear equations. The system is solved using a fast and accurate iteration procedure. Transient simulations are solved using the Crank-Nicolson finite difference method [4]. This method meets the criteria of the standard STN EN ISO 10211 Annex A, for software computing methods.

For the comparison of both simulations modelling procedures, simplified and detailed window frame models are used.

5. Results

The results from the simplified model calculation are marked θ_{xs} and from the detailed one are marked normally θ_x . The dot lines in the Fig. 5 represent results in the points from detailed model and full lines represent the simplified model results.

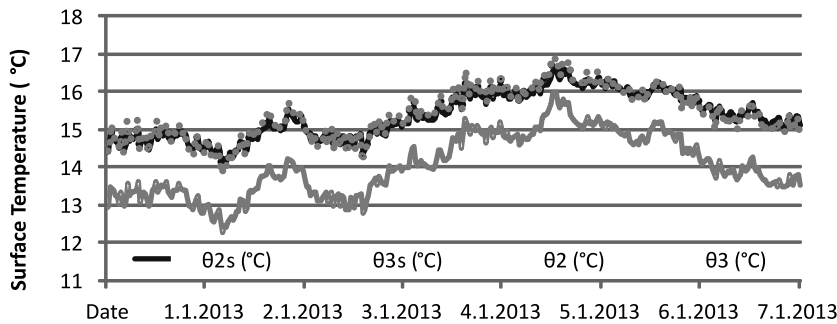

Fig. 4. Results of temperature calculation in points θ_2 , θ_{2s} , θ_3 , θ_{3s}

The analysis of the results from different models – simplified and detailed shows differences, Fig. 5. When comparing the averages of temperature in bottom profile and frame profile connection, point θ_{3s} has a lower temperature than the temperature in point θ_3 . The average temperature in θ_{3s} is only 14.04°C, while in θ_3 it is 15.39°C, so the average difference is 1.35 K.

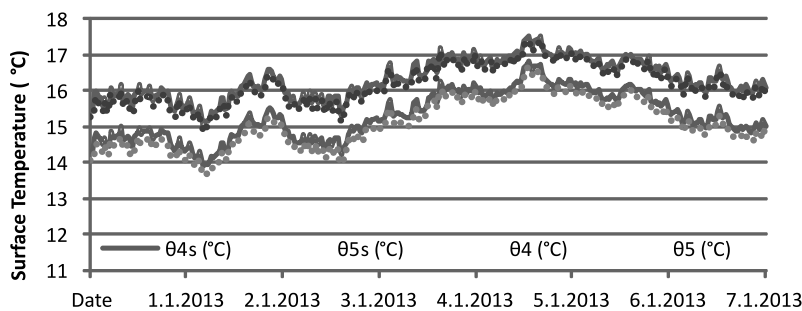

Fig. 5. Results of temperature calculation in points θ_4 , θ_{4s} , θ_5 , θ_{5s}

The maximum difference is 1.56 K on 2.1.2013, 4:00 am. The minimum difference between them is 0.88 K on 5.1.2013, 12:00. Average difference in the nook of the brick wall and bottom window frame profile connection temperature results, thus between points θ_{2s} and θ_2 is 0.05 K (Fig. 5).

Maximum differences between models in place of glass system and frame system connection θ_4 and θ_{4s} , and on the glass system θ_5 and θ_{5s} do not reach the 0.5 K, Fig. 6. Average difference on the place mentioned first, is 0.23 K and 0.15 K in the place θ_5, θ_{5s} .

6. Conclusions

The subtlety and strictness of modelling frame profiles of windows affect the surface temperature in the surrounding structures. Especially when the window sill detail is analysed, some of the results differ between detailed and simplified models. The most influenced is the bottom profile and the frame profile connection with average difference between values of 1.35 K. It is conspicuous when we look at the model (Fig. 2). Air cavity presence performed different thermal field patterns in the mentioned place. Any other places of window sill (or connection generally) detail are less sensitive to geometry and thermophysical changes caused by air cavities in window frame profile. Material connection of window and opaque wall part is influenced the least where the average difference is only 0.05 K. The points on glass system are also affected by air cavity presence. The further place from frame reaches the lower difference between values calculated in detailed and simplified models. The average values difference is 0.15 K, while in the nearest place to the window frame it is higher, at 0.23 K. As it is shown, detailed window frame profile modelling has influence on the surface temperature. Its use depends on the purpose of modelling, task severity (requested calculation exactness) and the point where we want to measure the surface temperature.

This contribution was created and realized through collaboration with the research project VEGA 1/1060/11 "Monitoring changes in physical parameters of envelope constructions in quasi-stationary conditions".

References

- [1] Asdrubali F., Baldinelli G., Bianchi F., *Influence of cavities geometric and emissivity properties on the overall thermal performance of aluminum frames for windows*, Energy and Buildings 60, Elsevier B.V., 2013, 298-309.
- [2] Bagoňa M., Lopusniak M., Vertal' M., *Numerical analysis of the hygrothermal performance of selected building structures in Slovak climatic conditions*, 12th Conference of International Building Performance Simulation Association, Sydney 2011, 2263-2268.
- [3] Katunský D. et al., *Monitoring in situ and Experimental Laboratory Physical Aspects of Building Skins*, Czasopismo Techniczne, vol. 109, no. 3, 2012, 199-203.
- [4] Physibel Software, *User manual for Physibel*, Maldegem, Belgium 2013.