

SELECTED SEQUENCES OF CHIP BREAKING PROCESS IN TURNING NICKEL ALLOYS

Bogdan Słodki

Summary

The paper presents a modern method for supervising phenomena in cutting zone with high speed camera monitoring system. A few selected sequences of chip forming and breakage in longitudinal turning have been presented. Workpiece material included Inconel 625 and 718. Tools recommended by Sandvik Coromant and ISCAR have been tested. Correct sequences as well as examples of anomalies in chip breakage have been depicted and discussed. An example of using the method for determining useful chipformer application area in local machining environment has been included.

Key words: turning, superalloys, chips, monitoring

WYBRANE SEKWENCJE CYKLU ŁAMANIA WIÓRA W TOCZENIU STOPÓW NIKLU

Streszczenie

Artykuł prezentuje nowoczesną metodę obserwacji zjawisk w strefie skrawania z wykorzystaniem kamery szybkoobrotowej. Przedstawiono wybrane sekwencje powstawania i łamania wióra w toczeniu wzdłużnym. Materiałem obrabianym były stopy Inconel 625 i 718. Testowano narzędzia rekomendowane przez firmy Sandvik Coromant i ISCAR. Pokazano zarówno sekwencje poprawnego procesu powstawania wióra jak i szereg zaobserwowanych anomalii w tym procesie. Zaprezentowano przykład użycia metody do wyznaczania użytecznego obszaru zastosowania związka wióra w lokalnych warunkach obróbki.

Słowa kluczowe: toczenie, superstopy, wióry, monitoring

1. Introduction

The implementation of modern methods for recording high speed images in research concerning phenomena in chip breakage zone in turning operations enables to gather information which can not be collected with naked eye [1]. This enables to verify some theoretical models describing breaking process in a practical way [2] [3]. Research activity was concentrated on turning representatives of difficult – to – cut materials, Inconel 718 and Inconel 625. Tools produced by Sandvik – Coromant and ISCAR have been used.

Inconel 718 and Inconel 625 belong to super alloys (HRSA - Heat Resistant Super Alloys) which cause some problems during machining. For the nickel-, iron- and cobalt-based superalloys, high temperature characteristics translate directly to machining challenges. The combination of high cutting force and high temperature when machining these materials leads to edge breakdown of the tool through chipping or deformation.

Address: Bogdan SŁODKI Ph.D. Eng., Cracow University of Technology, Production Engineering Institute,
al. Jana Pawła II 37, 31-864 Cracow, phone (0-48, 12) 437-32-12, fax: (0-48, 12) 374-32-02, e-mail:
słodki@m6.mech.pk.edu.pl

Additionally, for the majority of these metals, workpiece hardening takes place rapidly. Hardened surface created during machining can result in depth-of-cut-line notching of the tool and may also compromise the fatigue strength and geometric accuracy of the part. Chips are usually difficult to control. The machinability of HRSA strongly depends on the prior treatment of the material so high temperature alloys merit special machining techniques. Tool manufacturers devote special attention to these problems and describe them in special guide-books [4].

Conveyed tests have also enabled to verify the chipformers effectiveness under local operating features.

In turning there are two main ways of chip breaking which are known and applied. The first one is when a chip is forced to hit flank surface of a tool, the second one is when a chip is forced to hit a workpiece rough surface. It is assumed that similar ways of chip breakage is to take place in machining two tested alloys. There are also some brittle materials like cast iron when self breakage process takes place.

2. Research aim, object and stand

The aim of research was to observe record and analyze chip breakage sequences in longitudinal turning of Inconel 718 and 625 alloys. The recordings have been made with the speed 1000 and 3100 frames/sec in resolution 512x512 pixels up to 1152x896 pixels. Machining data were in the range of data recommended for particular chipformers by tool manufacturers. Then, some frames were extracted from recordings, processed and put together in particular sequences.

Tests were conveyed with Sandvik Coromant and ISCAR tools. Sandvik Coromant has been represented by an insert WNMG 080404-23, grade 1105 and toolholder PWLNR 2020K 08, entering angle 95° . Fig. 1 shows the tool and cross section of -23 chipformer. Recommended application area included depth of cut $a_p = 0,5 - 4,0$ mm, feed $f_n = 0,1 - 0,3$ mm/rev.

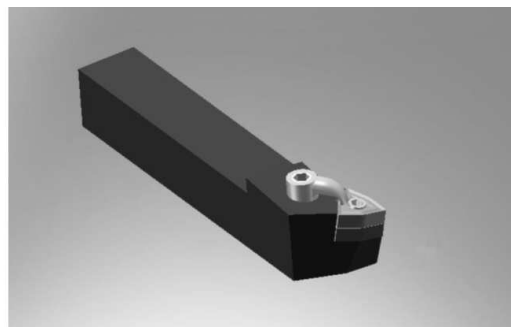
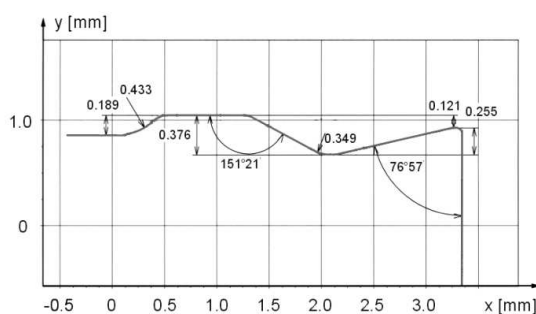

Fig.1. 3-D model of Sandvik Coromant tool and -23 chipformer cross section

ISCAR recommends for nickel alloy turning an insert VCMT 160404 with -SM chipformer geometry, grade IC 907 coated with TiAlN layer (Fig. 2) Chipformer recommended application area: $a_p = 0,5 - 2,5$ mm, $f_n = 0,05 - 0,25$ mm/rev.

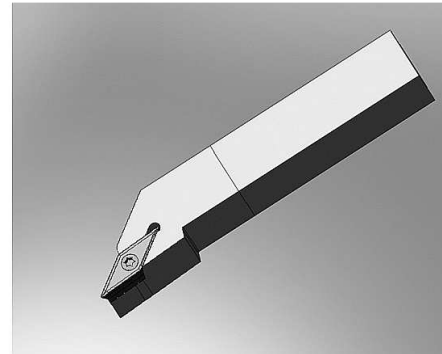
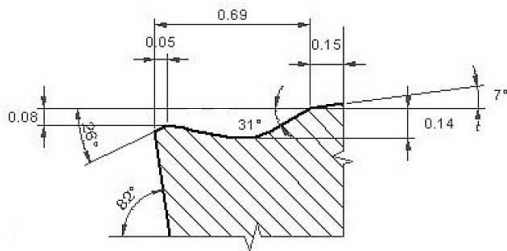

Fig. 2. 3-D model of ISCAR tool and -SM chipformer cross section

All tests have been performed on a specially prepared test stand [1]. The stand (Fig. 3) has consisted of:

1. High speed camera Phantom V5.2
2. Lens Nikkor AF Micro 200 mm f/4D IF-ED
3. Various lighting systems
4. Cine Viewer computer program for recording and picture processing
5. Precision lathe for testing tools and work materials



Fig. 3. Test stand for recording phenomena in cutting zone in turning

3. Examples of correct chip breaking cycles

Next pictures depict selected examples of correct cycles of chip breakage. Fig. 4 shows the correct if not perfect sequence of chip breaking by hitting flank surface of the tool. Created chips are correct, short and flowing in feed direction.

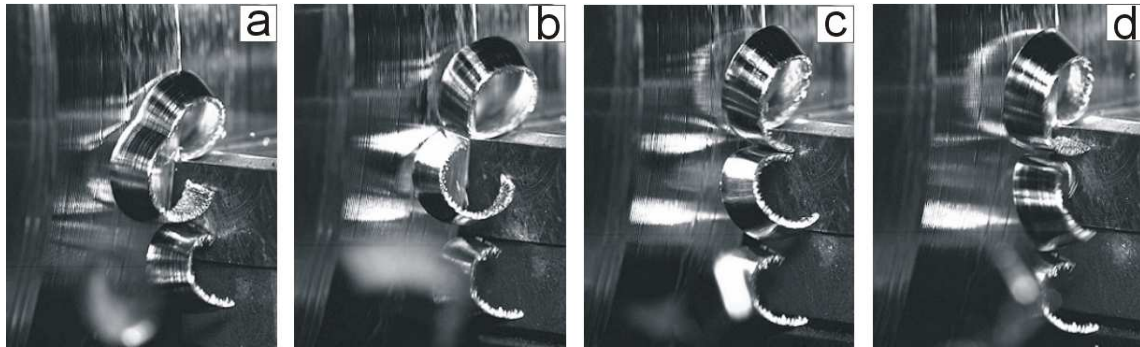

Fig. 4. Correct chip breaking sequence: Inconel 718, $v_c=75$ m/min, $f_n = 0,211$ mm/rev, $a_p = 2,0$ mm, chipformer -23 recording 1000 fps, period between frames a) and f) was is 6ms, c) chip brakes and separates after hitting the flank face

Another example presents the sequence of chipbreaking in turning Inconel 625. It has been recorded from the rake face direction (Fig. 5). Generally the process of chipbreaking is correct, but there was an “additional” chip formed (pointed by the white arrow). It is assumed that this chip is created not by cutting process but by metal embossing with the insert cutting edge. This phenomenon can be the reason for increased insert notching wear which is typical of Inconel turning. Too large cutting edge radius (in presented case $r_n = 0,035$ mm) can make cutting process difficult.

Next example shows chip breaking process by hitting raw surface of the workpiece (Fig. 6). Interesting thing is, that in spite of cyclic character of this phenomenon it can be observed that situation presented in Fig. 6a may not necessary develop in situation shown in Fig. 6b. This will be described below.

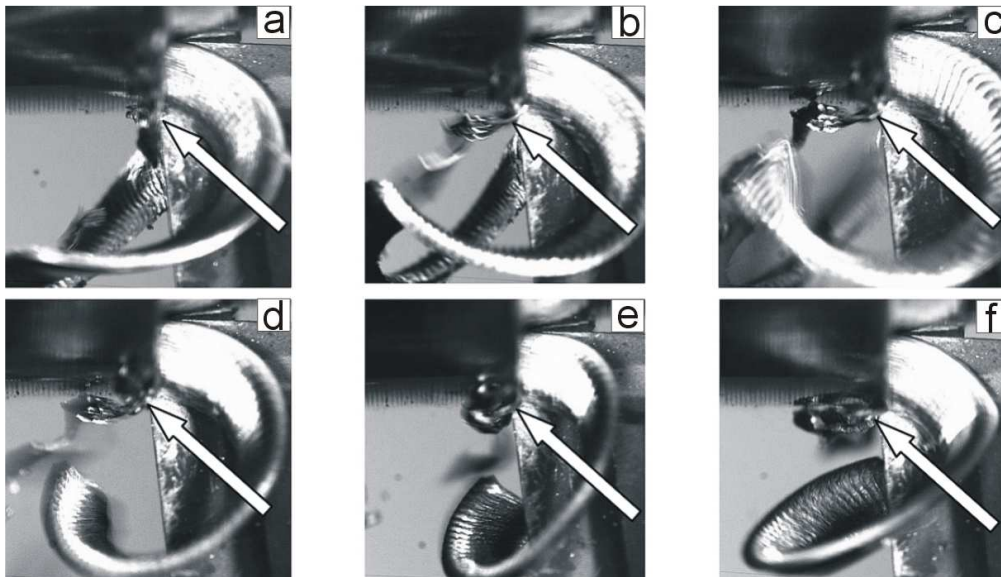

Fig. 5. Sequence of correct chip breaking seen from rake face direction: Inconel 625, $v_c=75$ m/min, $f_n = 0,211$ mm/rev, $a_p = 1,5$ mm, chipformer -23, selected 6 frames out of 23, recording 3100 fps, period between frames a) and f) is 1,65 ms, white arrow points out “additional” chip created by plastic deformation

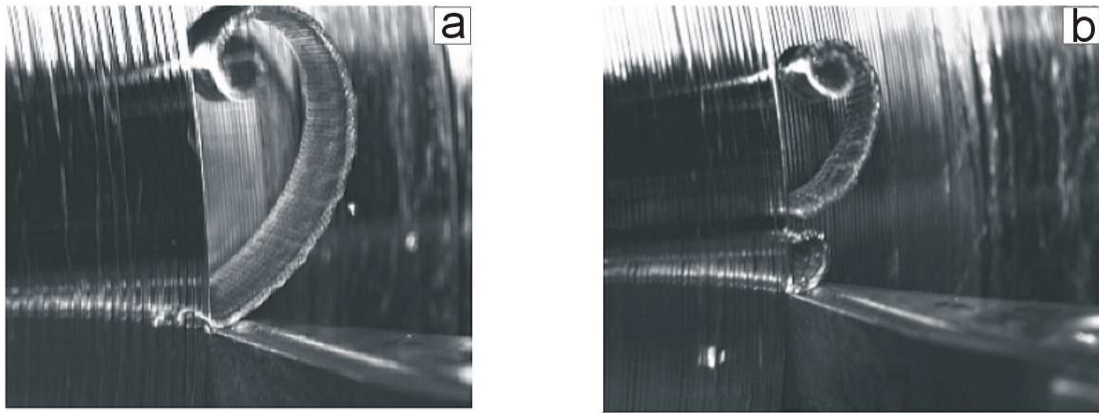

Fig. 6. Chipbreaking by hitting workpiece raw surface: Inconel 625 $v_c = 65$ m/min, $a_p = 2,5$ mm, $f_n = 0,153$ mm/rev, chipformer –SM; a) chip hits raw surface of the workpiece and bends back, b) bending strength is exceeded and the chip splits

4. Examples of anomalies in chipbreaking

Despite the fact that in some recommended by tool manufactures application areas chip breaking process is correct, a lot of anomalies can be observed leading to incorrect chip form. Fig. 7 is an example of radical change of chip form caused by different values of feed.

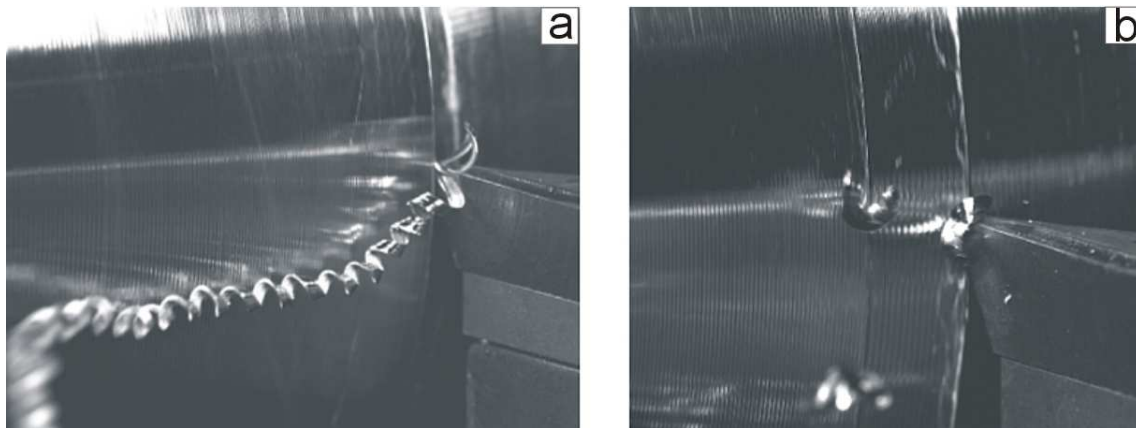

Fig. 7. Example of incorrect chip form, Inconel 625, $v_c = 65$ m/min, $a_p = 0,5$ mm, $f_n = 0,077$ mm/rev, and correct form for the same cutting speed and depth of cut but for the feed $f_n = 0,249$ mm/rev, recording 1000 fps, a) incorrect chip form, b) correct chip form,

Usually, it turns out that chipformers are more efficient for greater values of depth of cut and feed. The limit is the strength of insert material. When it is exceeded, catastrophic wear is inevitable.

Two ways of chipbreaking in one cut has also been observed. In Fig. 8 there are examples of chipbreaking cycles under the following cutting conditions: $v_c = 65$ m/min,

$a_p = 2,5$ mm, $f_n = 0,153$ mm/rev. Chips were formed by hitting workpiece raw surface or by hitting flank surface of a tool. Sometimes, although the beginning of breaking cycle seemed to end with hitting workpiece raw surface (Fig. 8b) it actually ended with hitting flank surface of a tool (Fig. 8d). It was random process.

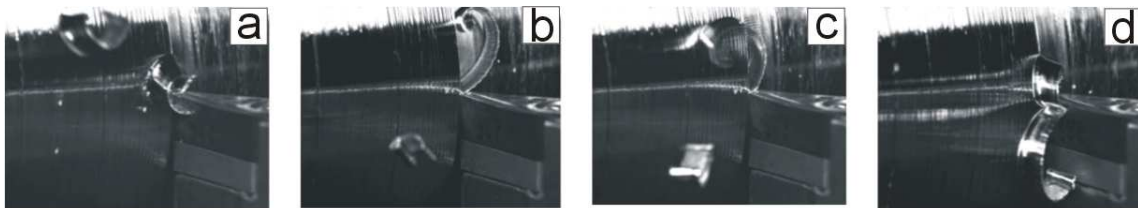

Fig. 8. Two kinds of chip breaking way in one cut, Inconel 625 $v_c = 65$ m/min, $a_p = 2,5$ mm, $f_n = 0,153$ mm/rev, chipformer -SM, recording 1000 fps, a) end of breaking cycle, b) chip hits the raw surface of the workpiece and bends back, c) suddenly chip slips to the left, d) breaking process ends by hitting flank surface of the insert

An atypical phenomenon is presented in Fig. 9. Despite the fact that cutting data followed the recommendations of tool manufacturer, incorrect chip form has been achieved. The chip bent in minor flank face direction and was out of control. Probably, when the tool began the cut, the chip groove was not filled enough to force the chip to move in the correct direction. Chips like this can destroy machined surface easily.

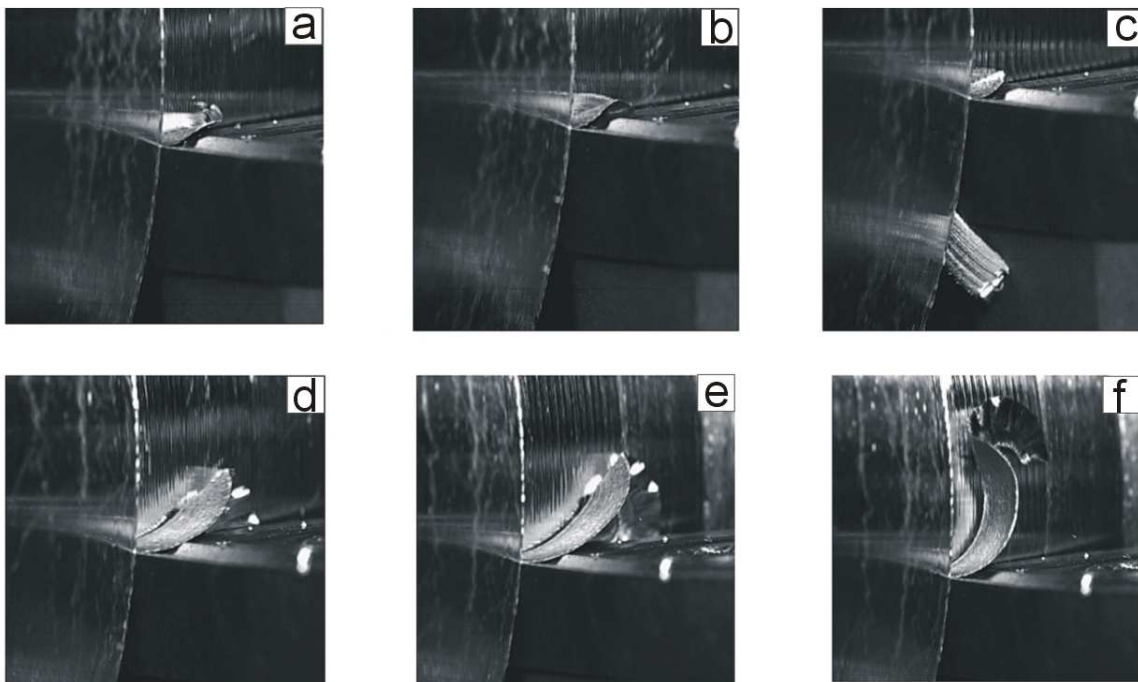

Fig. 9. Example of the lack of control over chip forming in Inconel 718 turning $v_c = 50$ m/min, $a_p = 2,0$ mm, $f_n = 0,211$ mm/rev, chipformer -23, recording rate 1000 fps, period between a) and f) is 79 ms, selection of 6 frames out of 79

5. Concluding remarks

The paper presents selected chip breaking sequences recorded at the Production Engineering Institute, Cracow University of Technology.

It is not easy task to present gathered collection of experimental films in sequences of pictures, films are more convincing. Nevertheless, some conclusions can be drawn.

Although for the individual sets of cutting data, correct chip form is achieved (Fig. 4 and 5), it does not mean that such a form will be for the whole range of cutting data recommended for particular chipformer. Fig. 10 shows examples of two chipformers useful application areas in local machining environment. In each case recorded chips have been classified into correct (+), acceptable (0) and incorrect groups. Fig 10a presents useful application area for -23 chipformer in turning Inconel 718, Fig. 10b presents useful application area for the same chipformer in turning Inconel 625.

Detailed examination of observed phenomena leads to the conclusion that current descriptions of chip forming process are correct for a single chip breakage cycle. It is so because chip forming and breaking process is influenced by many factors, like sudden changes in local workpiece material structure i.e. its heterogeneity, vibrations of a machine tool or variations of the temperature in cutting zone causing disturbances in chip curvature and the contact length between the chip and chipformer surface.

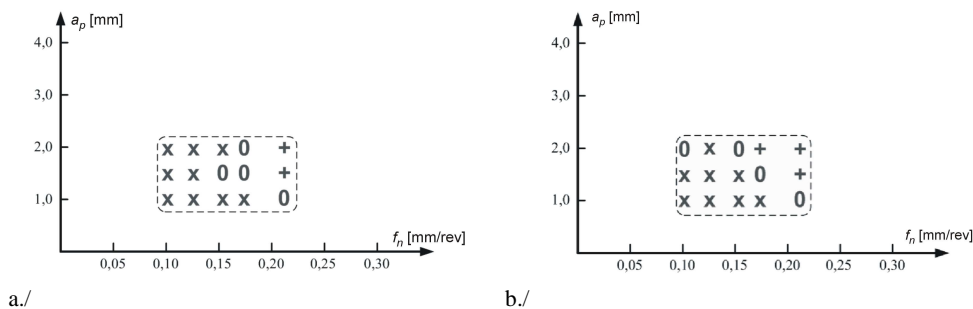

Fig. 10. Useful areas of chipformer -23 application in turning: a) Inconel 718 and b) Inconel 625

In the example shown in Fig. 4, the chip breaking frequency was about 40 Hz. It shows how difficult is to control this process in actual machining time. The algorithms concerning cutting data selection and testing can be helpful since the local machining environment [5] [6] has significant influence on actual chipformers application areas.

References

- [1] B. SŁODKI, W.ZĘBALA: Stanowisko do rejestracji obrazów szybkozmiennych w procesach skrawania, Obróbka skrawaniem zaawansowana technika pod redakcją Huberta Latosia, Bydgoszcz 2009, 215 – 220.
- [2] I.S. JAWAHIR, C.A. van LUTTERVELT: Recent Developments in Chip Control Research and Applications. *Annals of the CIRP*, **42/2**, 1993, 695 – 685.
- [3] A.J. PEKELHARING: Why and how does chip curl and break. *Annals of the CIRP*, 1964 12(1), 144 – 147.

- [4] SANDVIK Coromant - Przewodnik: *Superstopy żaroodporne*, 2004.
- [5] L. PRZYBYLSKI, B. SŁODKI: The influence of Local Operating Features on Cutting Parameters in Turning, *The International Journal of Advanced Manufacturing Technology* vol. 13, no. 4, 1997, 233 – 236.
- [6] B. SŁODKI, W. ZĘBALA: Efektywny zakres pracy zwijacza wiórów a lokalne warunki obróbki w toczeniu materiałów trudnoskrawalnych. *Obróbka Skrawaniem Innowacje* pod redakcją Jerzego Stósa, Kraków, 2008, 262 – 271.

The research was made as a part of research project, financially supported by means concerning science development in the years 2008 – 2010.