

# DIE HEBEZEUGE

VON

AD. ERNST.

ATLAS

Biblioteka Politechniki Krakowskiej



100000300382





# DIE HEBEZEUGE

THEORIE UND KRITIK AUSGEFÜHRTER KONSTRUKTIONEN

EIN HANDBUCH

FÜR

INGENIEURE UND ARCHITEKTEN, SOWIE ZUM SELBSTUNTERRICHT

FÜR STUDIRENDE

VON

AD. ERNST

INGENIEUR UND ORDENTLICHER LEHRER DES MASCHINENBAUES AN DER  
FACHSCHULE FÜR MASCHINENTECHNIKER ZU HALBERSTADT.

= ATLAS =

Invent. G. Fol. 124 N<sup>o</sup> 1/83.



BERLIN.

VERLAG VON JULIUS SPRINGER.

1883.

x  
76 775/2

DIE HERZEBÜCHER

STAMPED TEXT AT THE TOP OF THE PAGE, FADING OUT.



III - 307009

~~III 16894~~



~~STAMPED TEXT BELOW THE CANCELLED NUMBER~~



ARC. No. 4892/50

CPK B-142/208



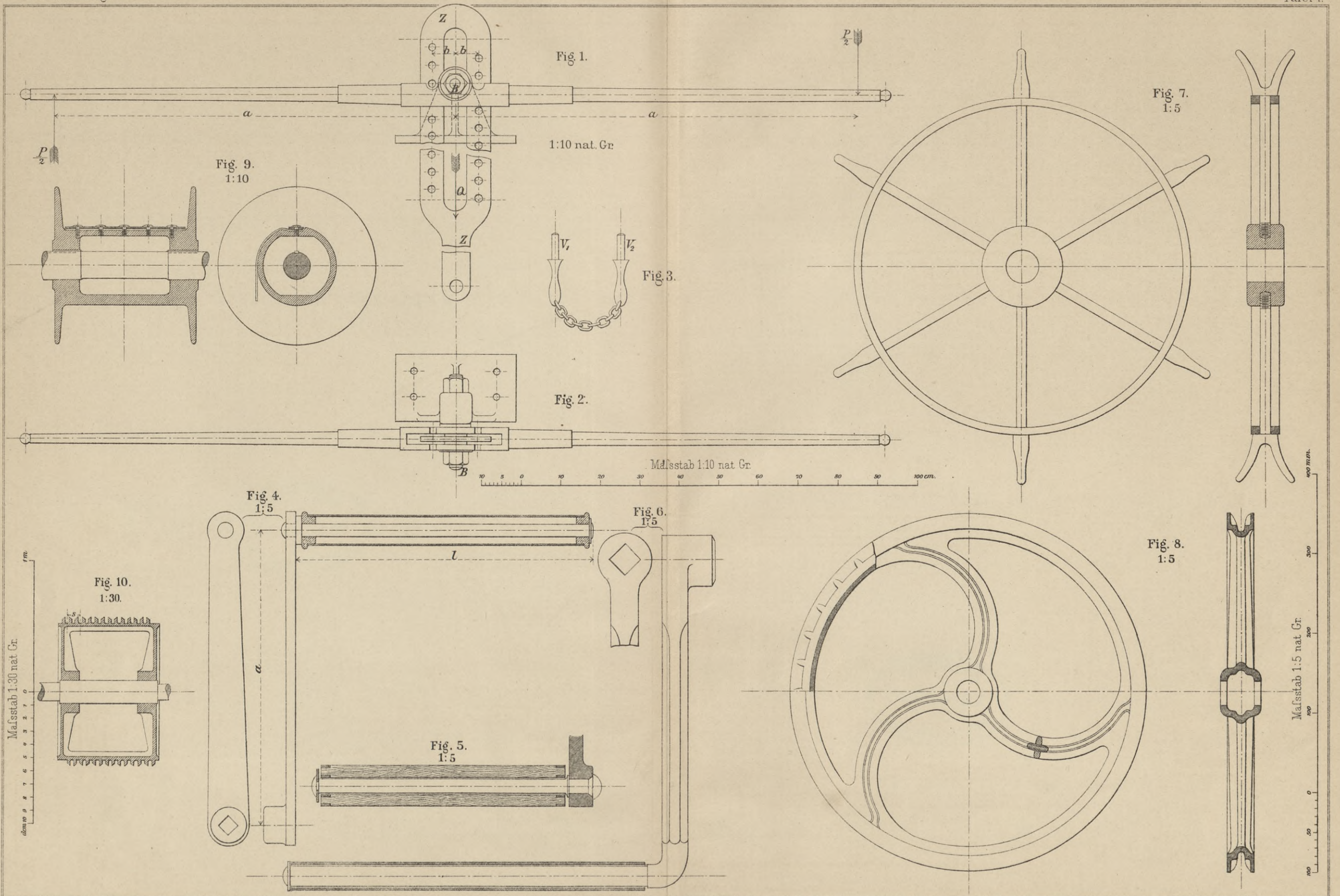







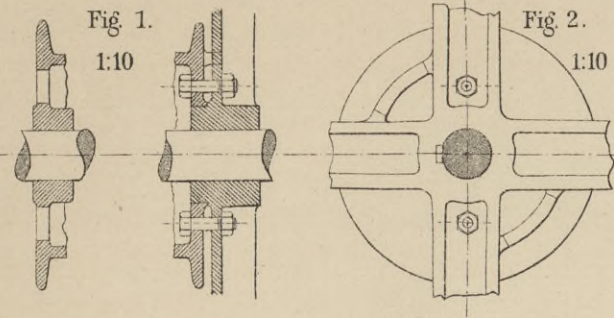

D.R.P. № 10953.  
F. Wiesche.

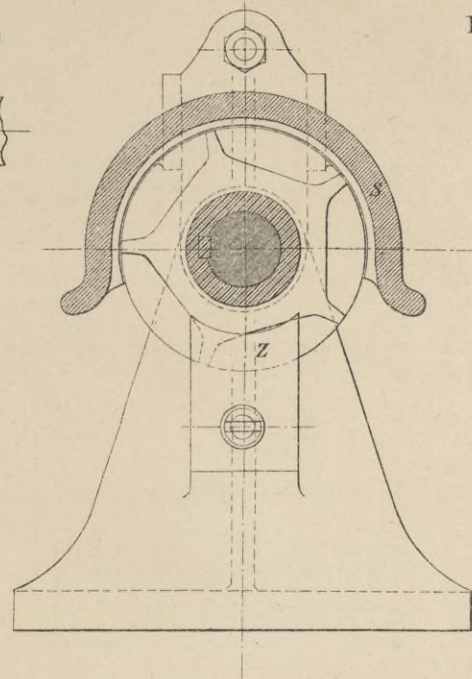
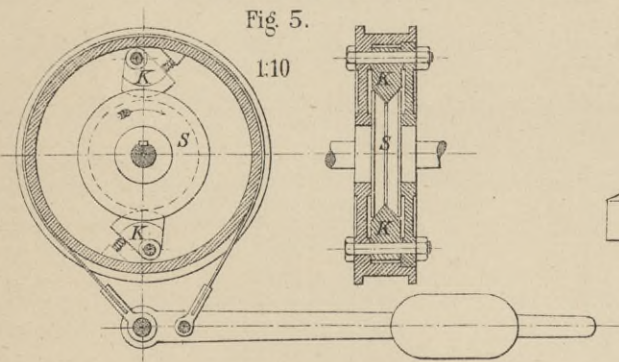

Fig. 3.  
1:5

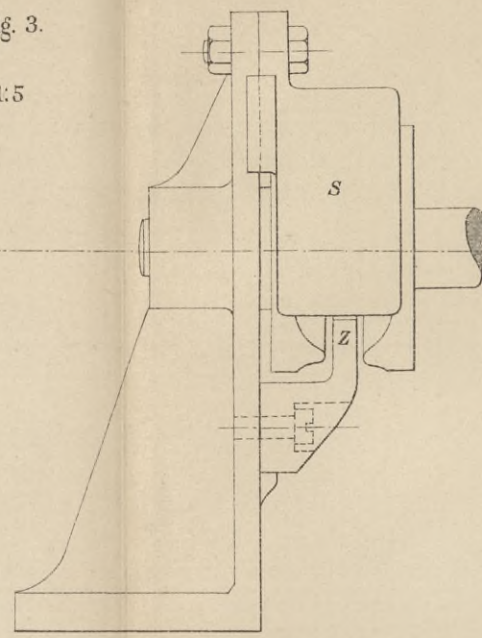
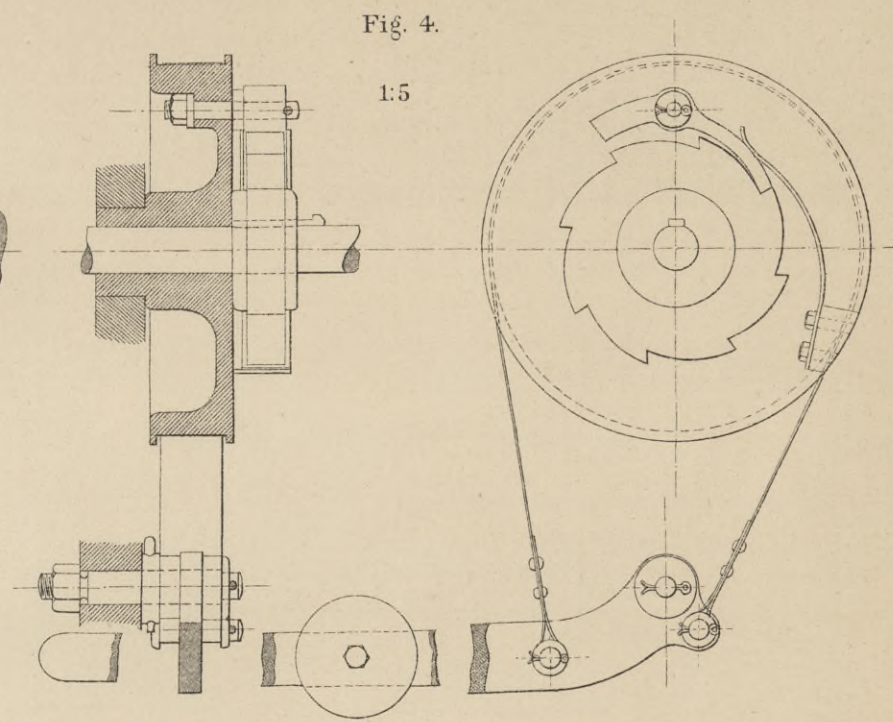

Fig. 4.  
1:5



D.R.P. № 11275.  
A. Kölle

Fig. 6.  
1:10

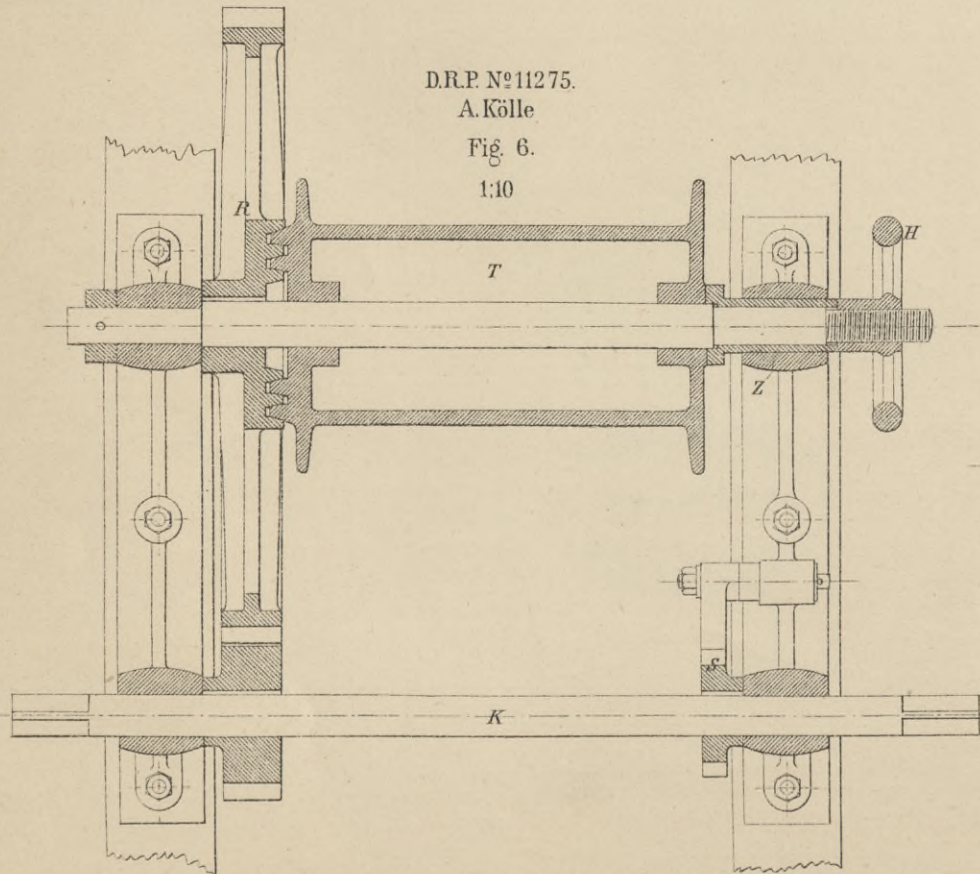
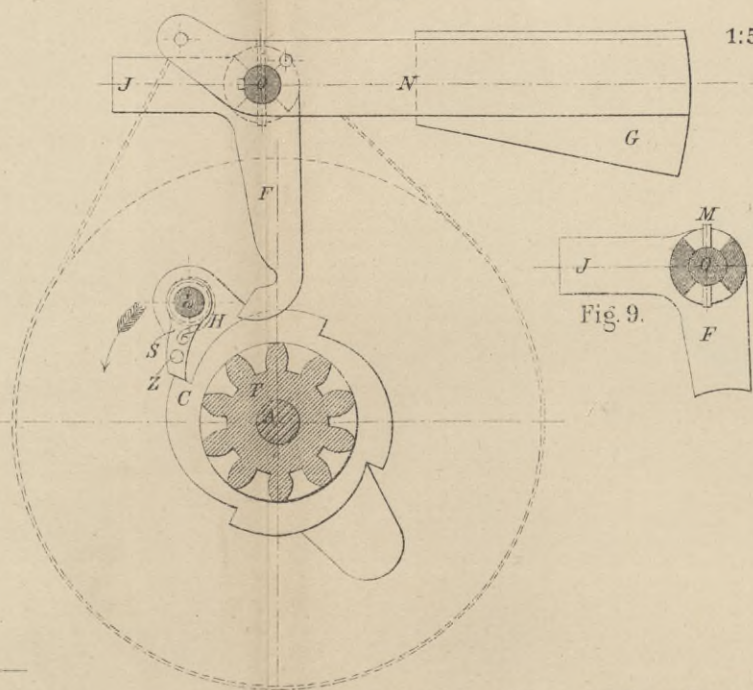

Fig. 7.



1:5

Fig. 9.

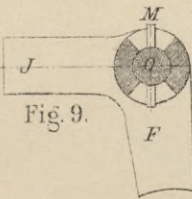
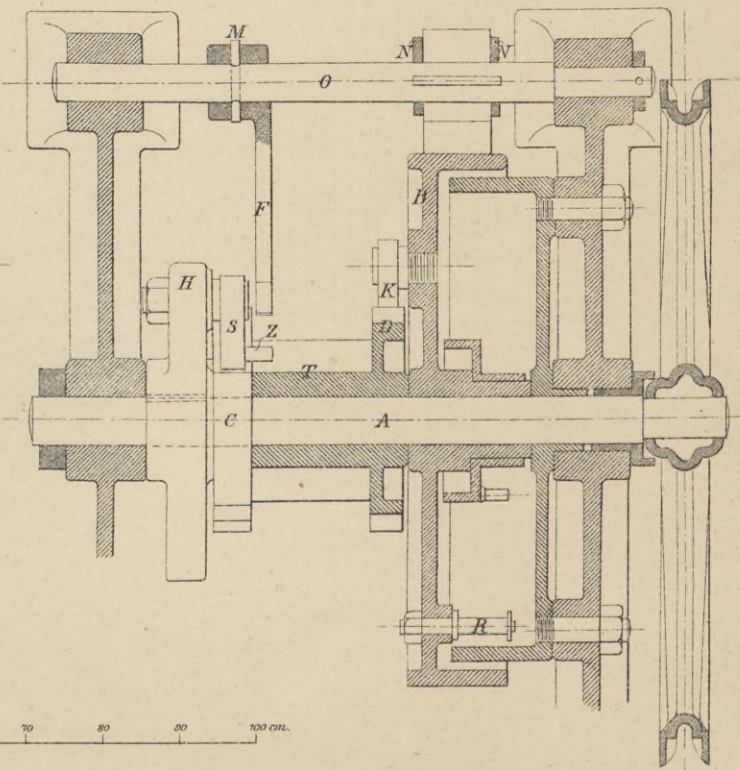
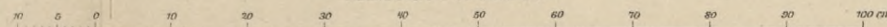

Fig. 8.



Mafsstab 1:10 nat. Gr.



Mafsstab 1:5 nat. Gr.

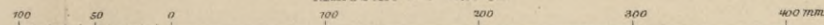





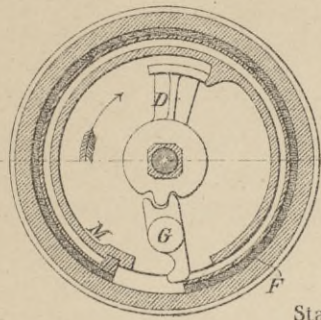

Fig. 1.

Stauffer & Mogy's Patent.

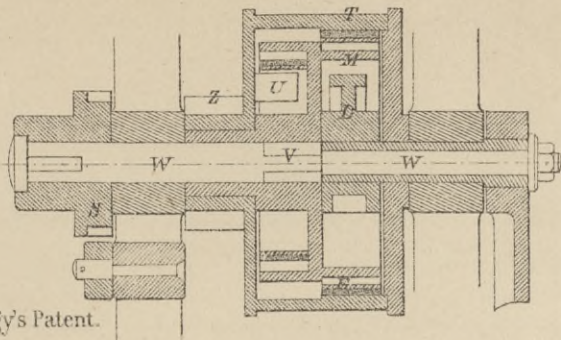

Fig. 3.

1:5.

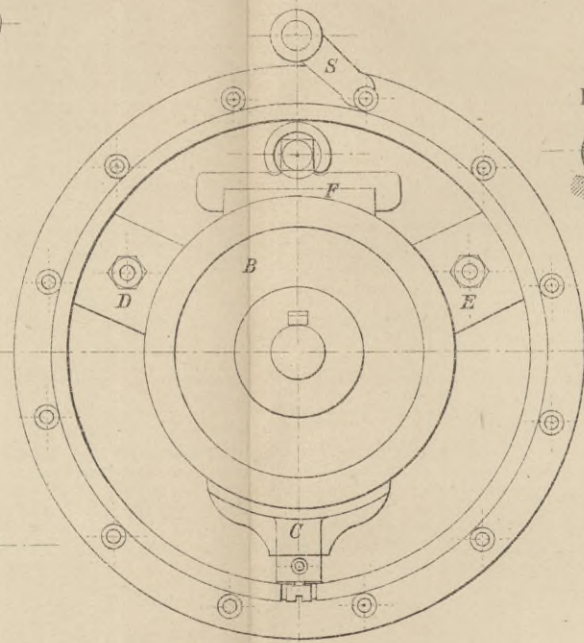

Fig. 4.

Fig. 6.

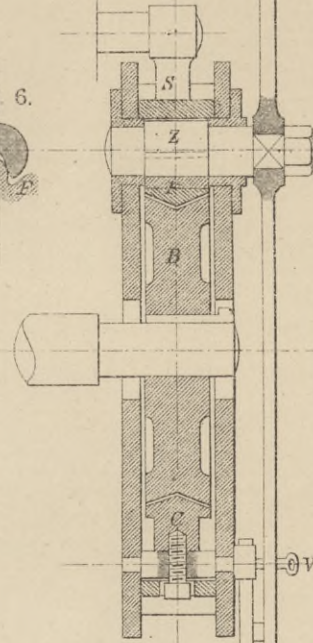
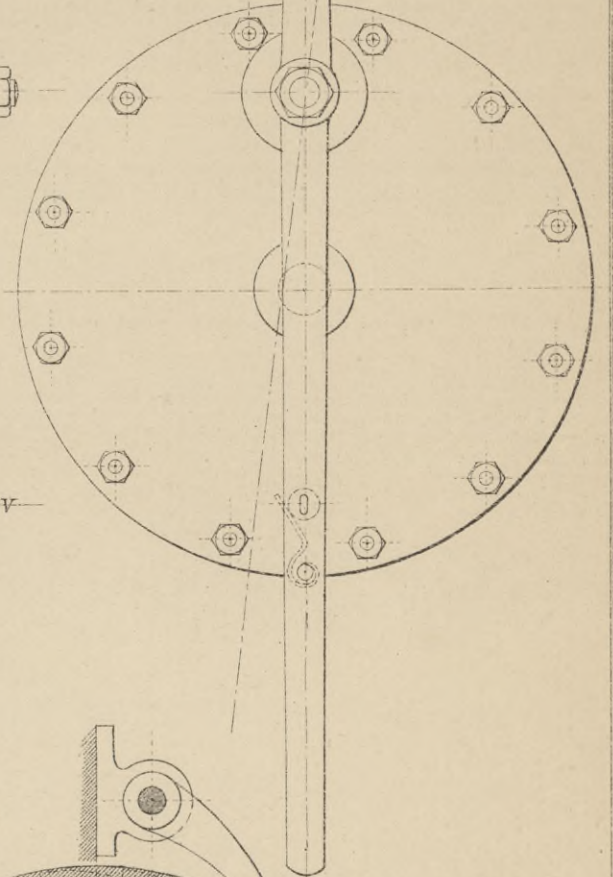

Fig. 5.



E. Becker. D.R.P. No 5801.

1:10

Fig. 2.

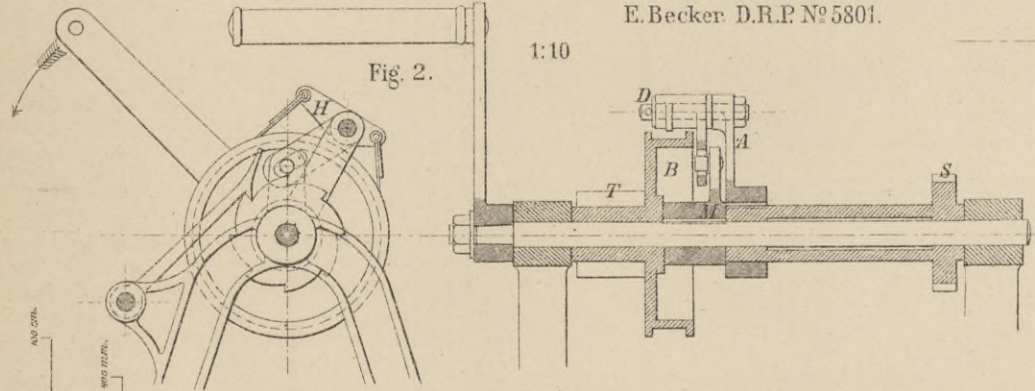

Selig D.R.P. No 6301.

Fig. 7.

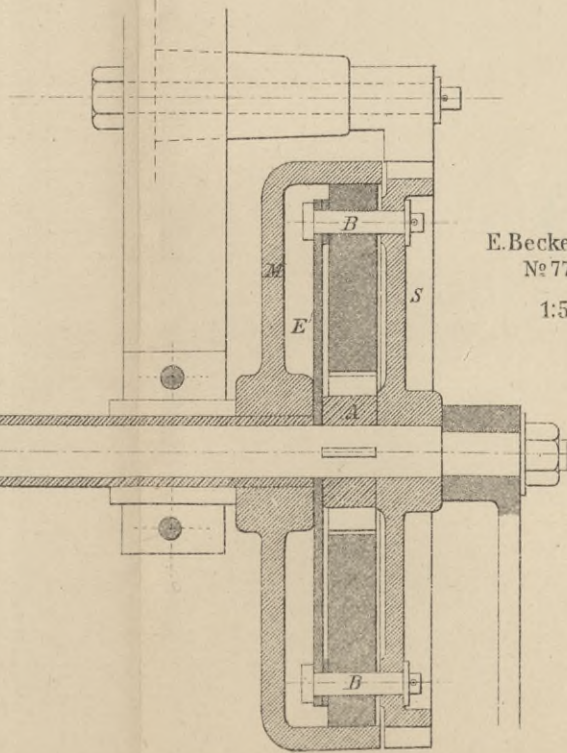

E. Becker. D.R.P. No 7742.

1:5

Fig. 8.

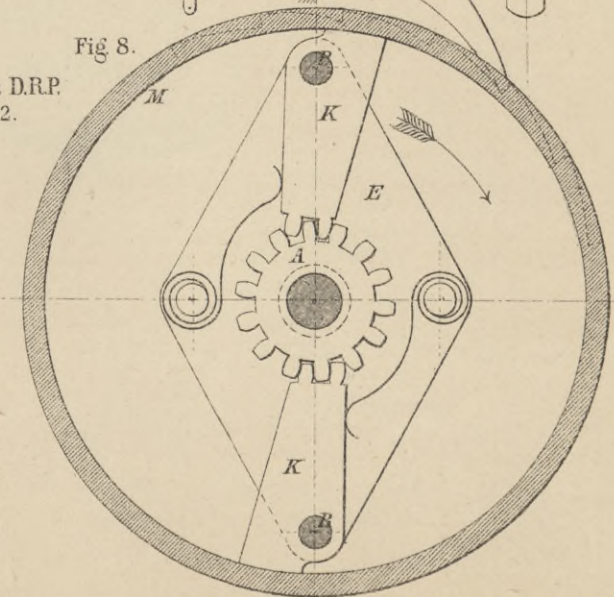

Maßstab 1:10 nat. Gr.

Maßstab 1:5 nat. Gr.

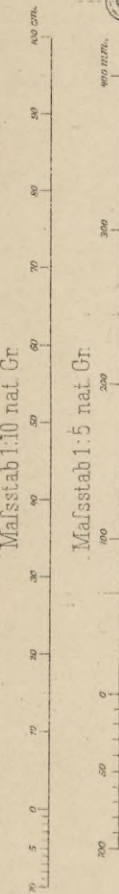







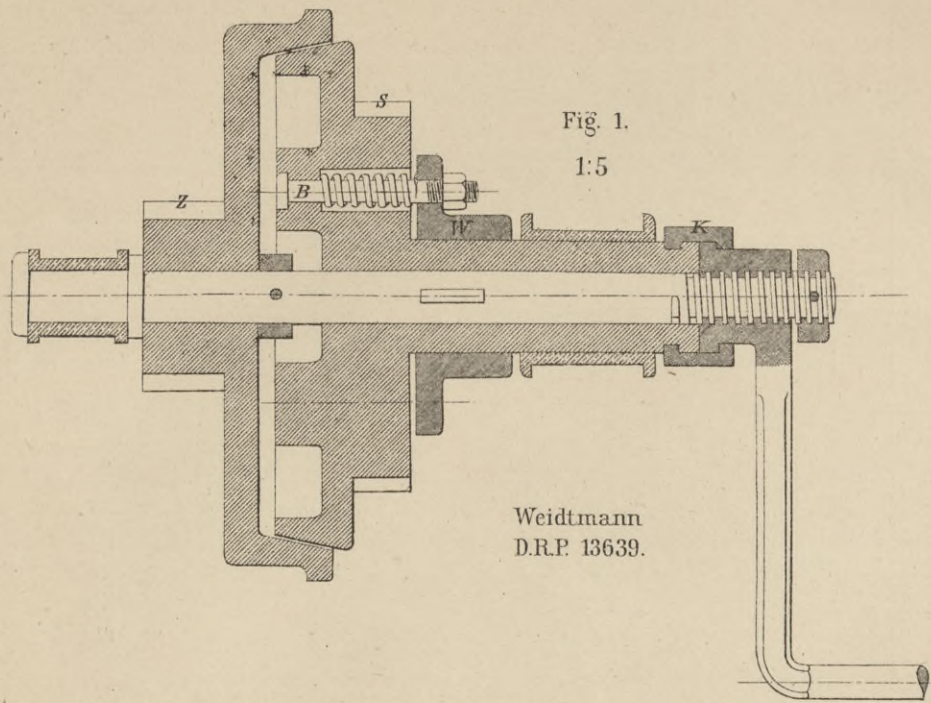

Fig. 1.  
1:5

Weidtmann  
D.R.P. 13639.

Mafsstab 1:5 nat. Gr

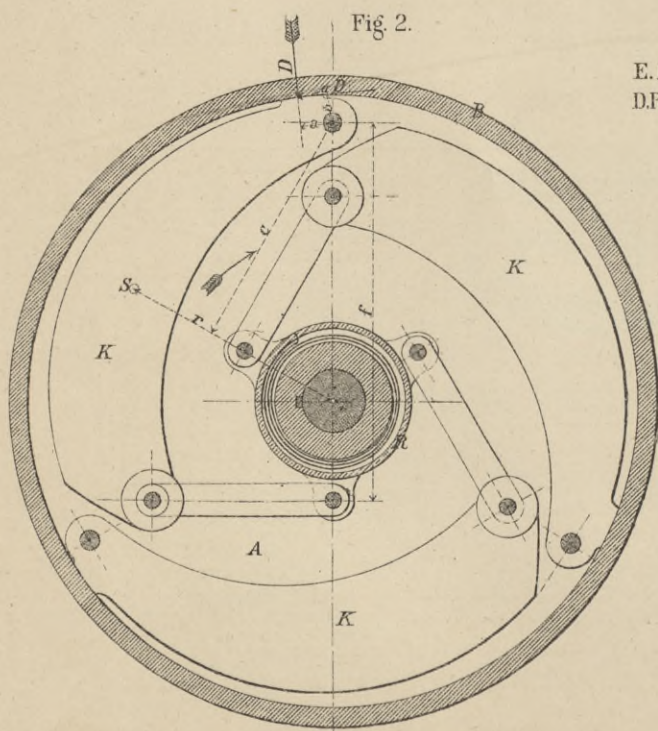
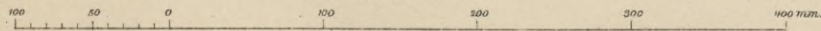

Fig. 2.

E. Becker  
D.R.P. 7205.

1:5.

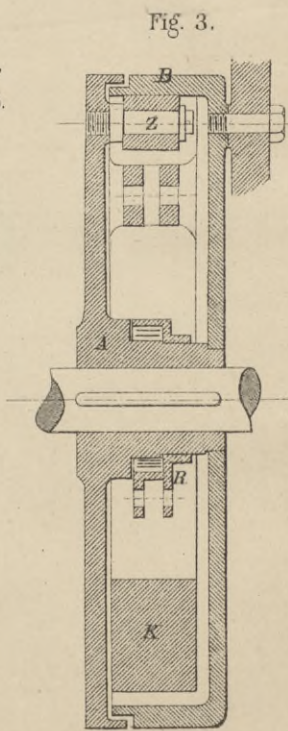

Fig. 3.

Winde von Tangye.

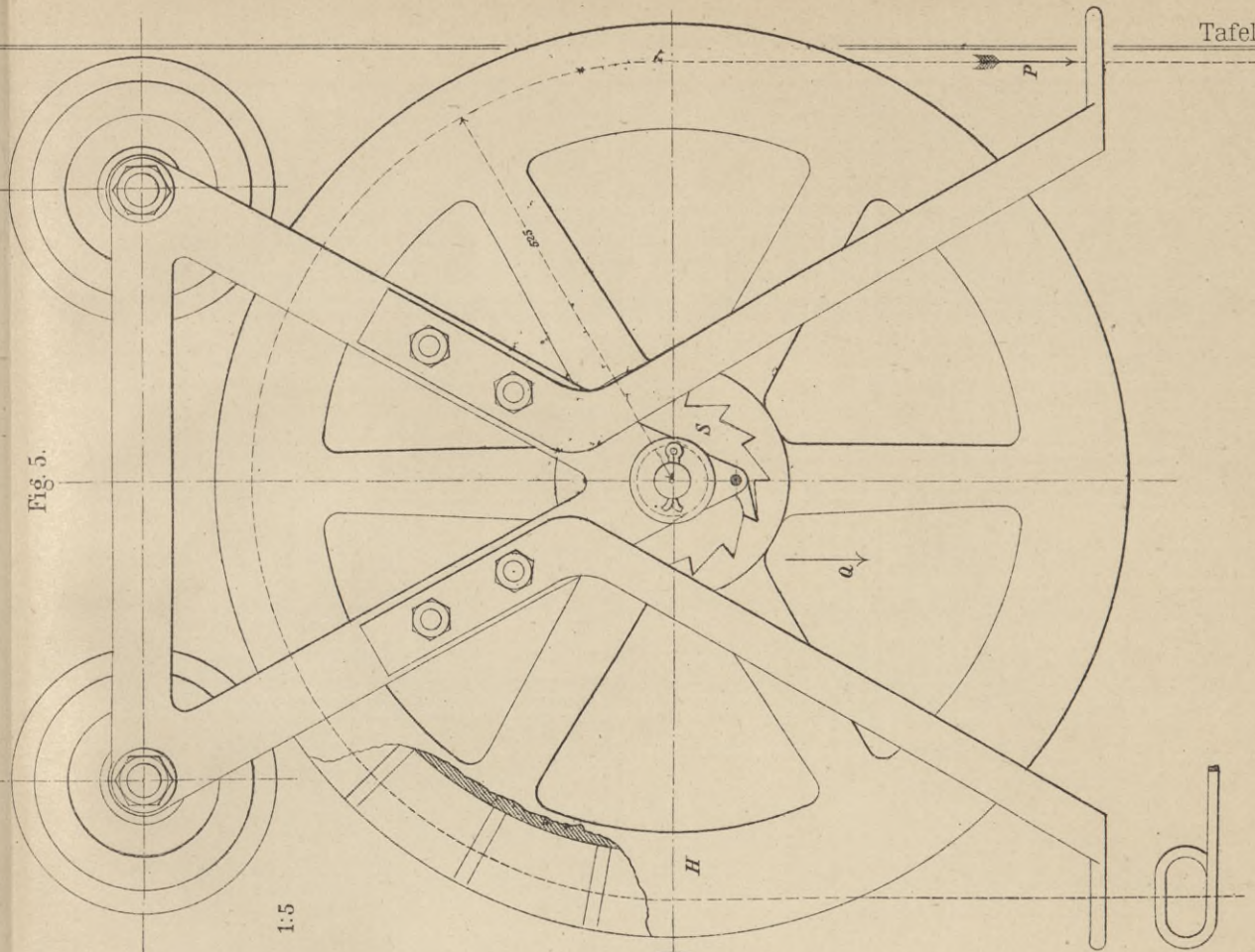

Fig. 5.

1:5

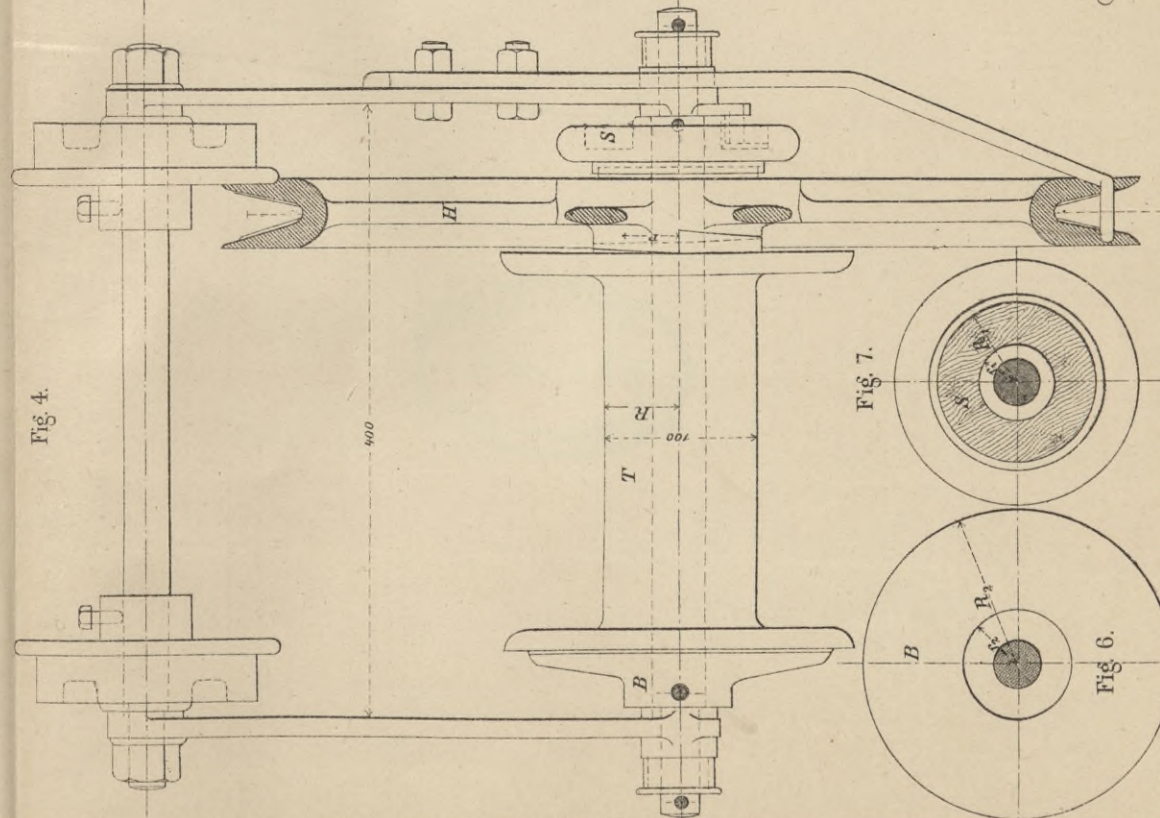

Fig. 4.

400

100

Fig. 7.

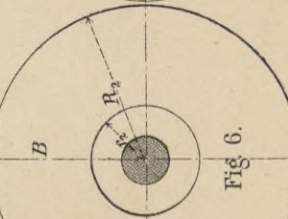
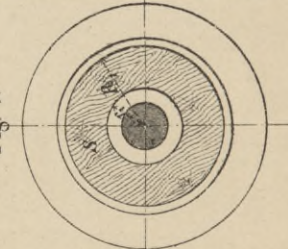

Fig. 6.



BIBLIOTEKA

KRAKÓW

\*  
Politechniczna



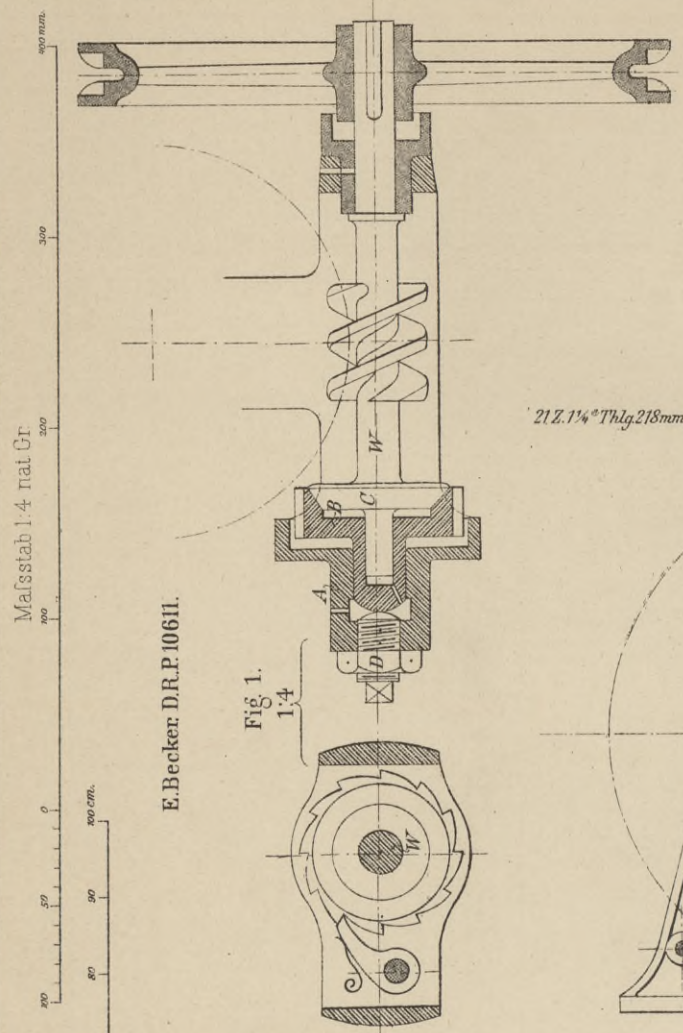

E. Becker D.R.P. 10611.

Fig. 1.  
1:4

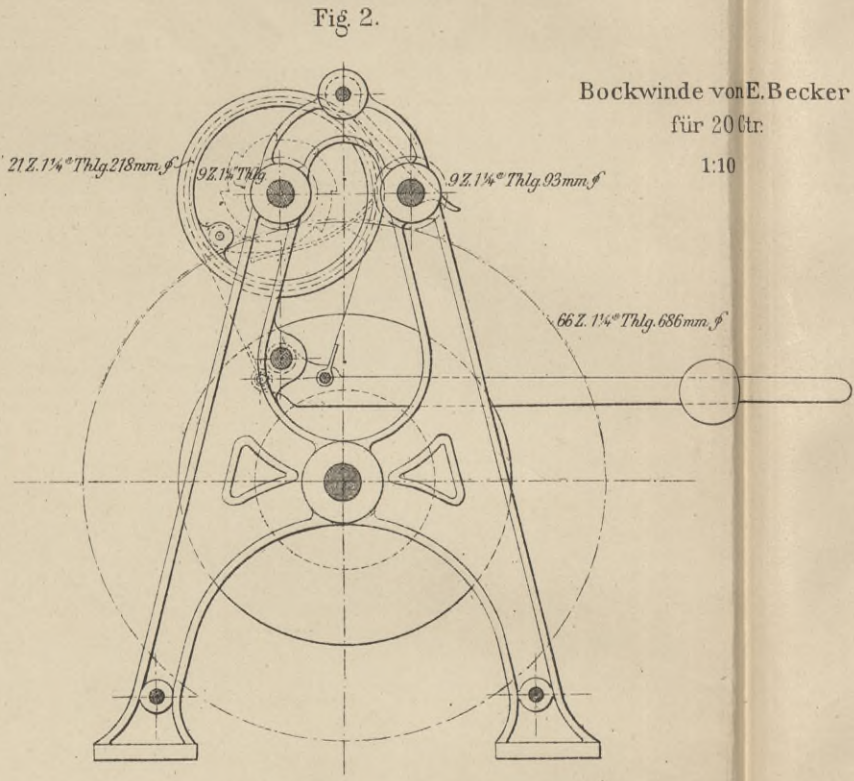

Fig. 2.

Bockwinde von E. Becker  
für 20 Ctr.  
1:10

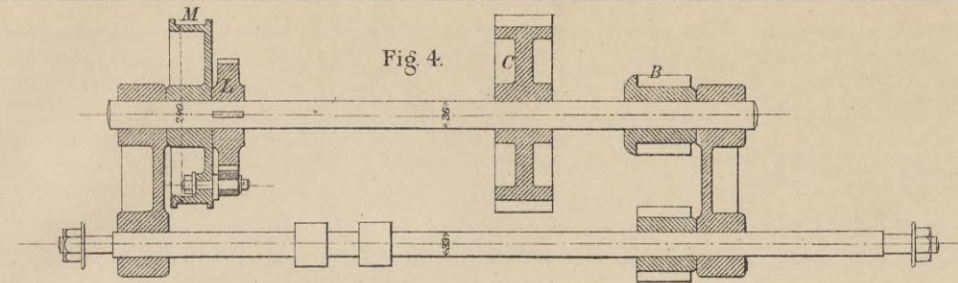

Fig. 4.

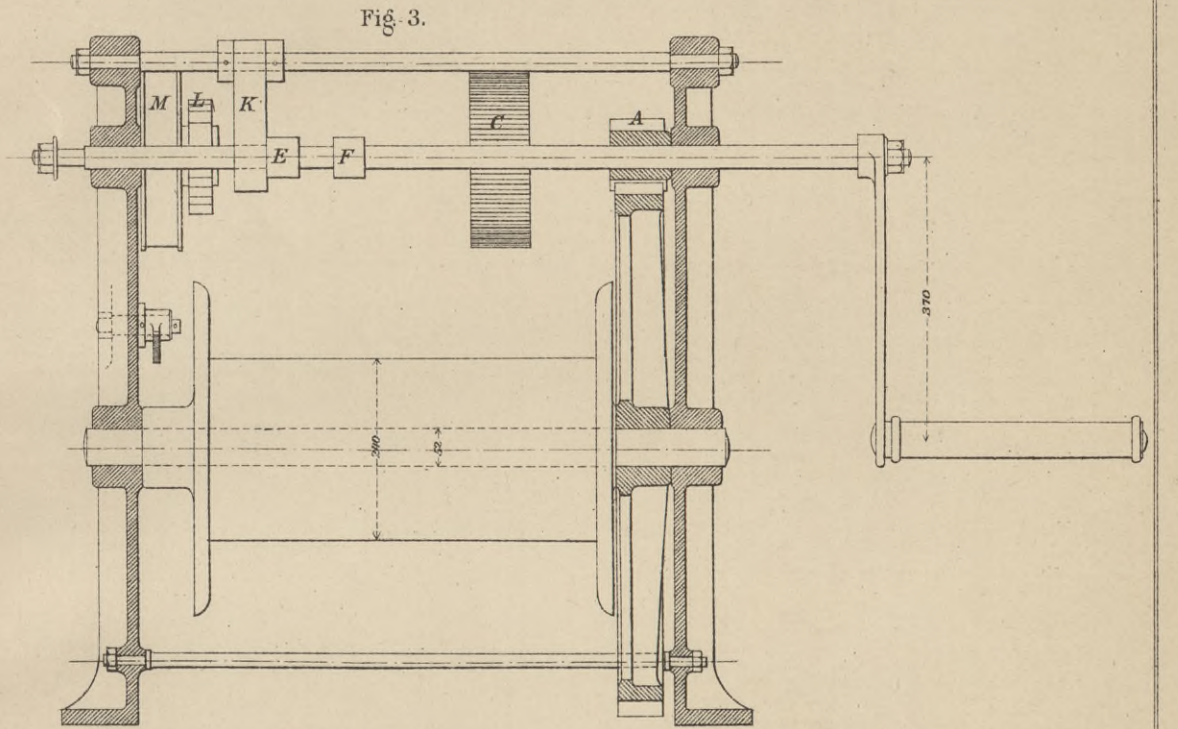

Fig. 3.

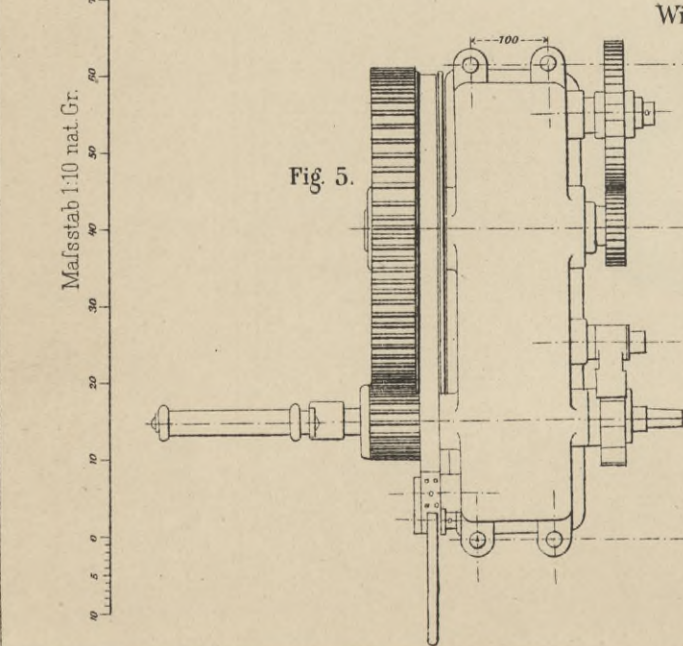

Fig. 5.

Winde mit Galle'scher Kette  
von  
Zobel, Neubert & C<sup>o</sup>

1:10

Fig. 6.

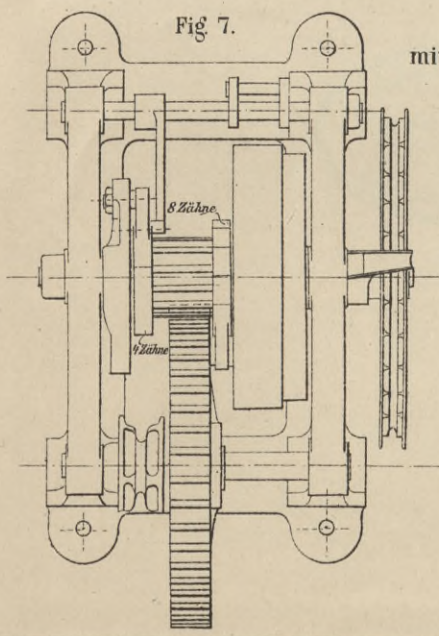
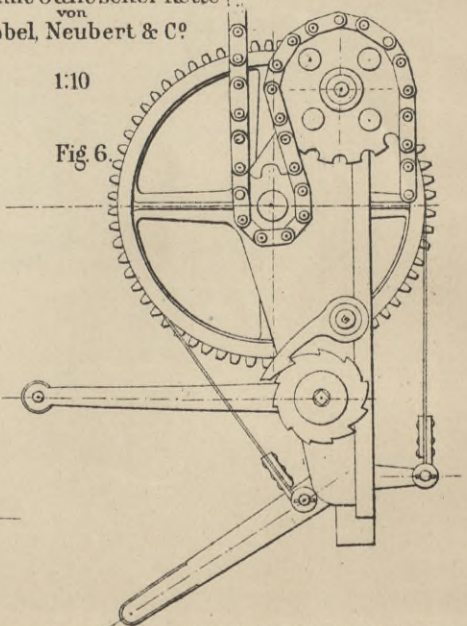

Fig. 7.

Winde  
mit Sicherheitshassel  
von  
E. Becker.

1:10

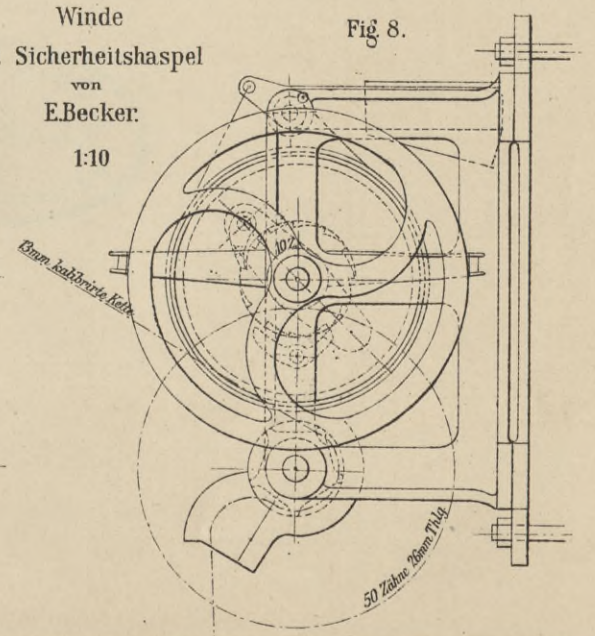
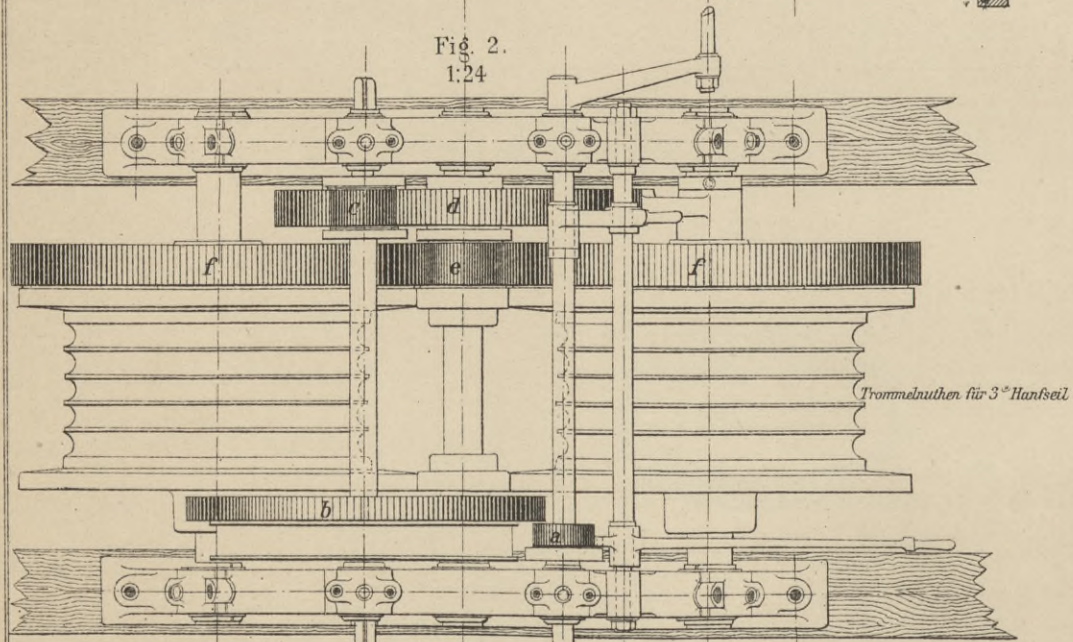
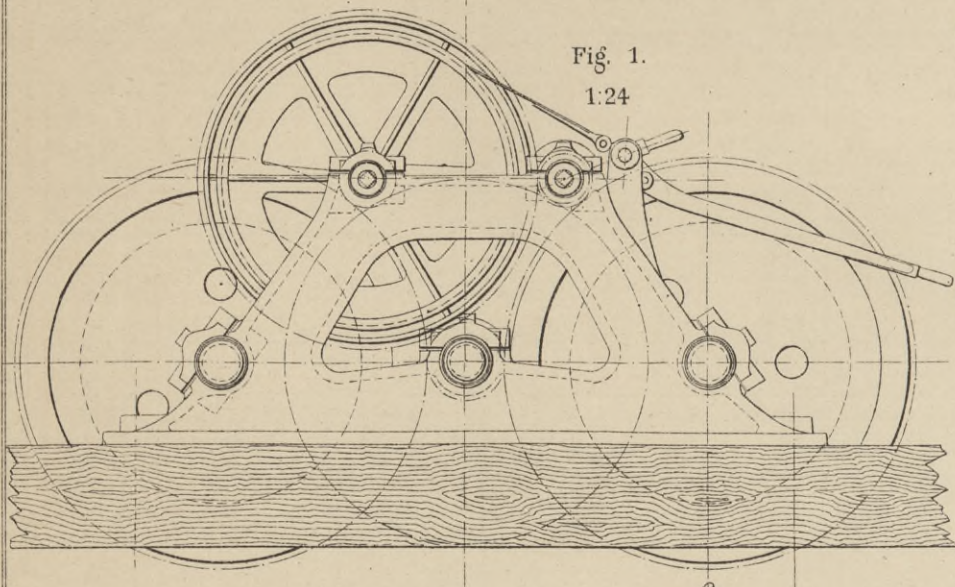

Fig. 8.





Friktionswinde  
der  
Kölnischen Maschinenbau-Aktien-Gesellschaft  
zu  
Bayenthal bei Köln a/Rhein.



Räder-Verzeichniss.

Pos.	Durchm.	Zähne	Stich	Brt.
a	0° 5 1/16"	10	1 3/4"	3°
b	3° 5 3/4"	75	"	"
c	0° 6 5/16"	10	2"	4 1/2°
d	3° 7 5/16"	68	"	"
e	0° 10 3/16"	13	2 1/2"	5°
f	3° 11 3/4"	60	"	"

Mafsstab 1:24 nat. Gr.

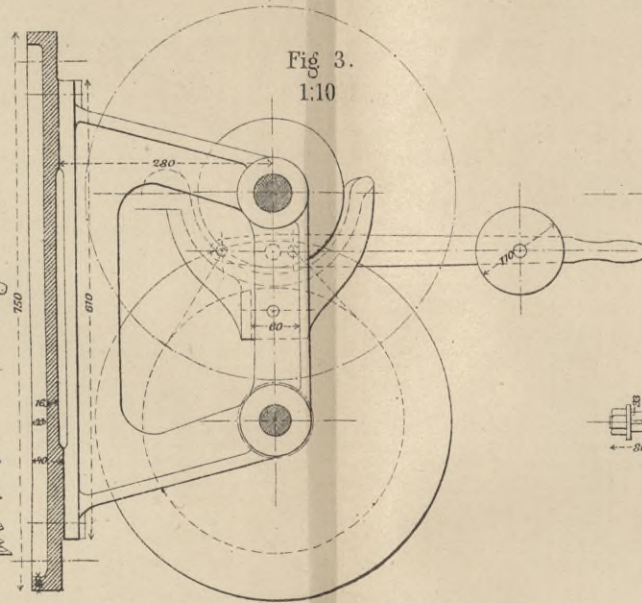
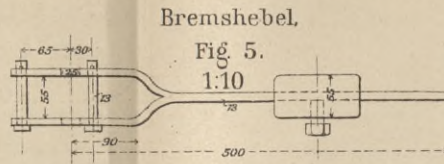

Winde mit Riementrieb  
für 750 kg am Daumenrade  
von  
E. Becker.

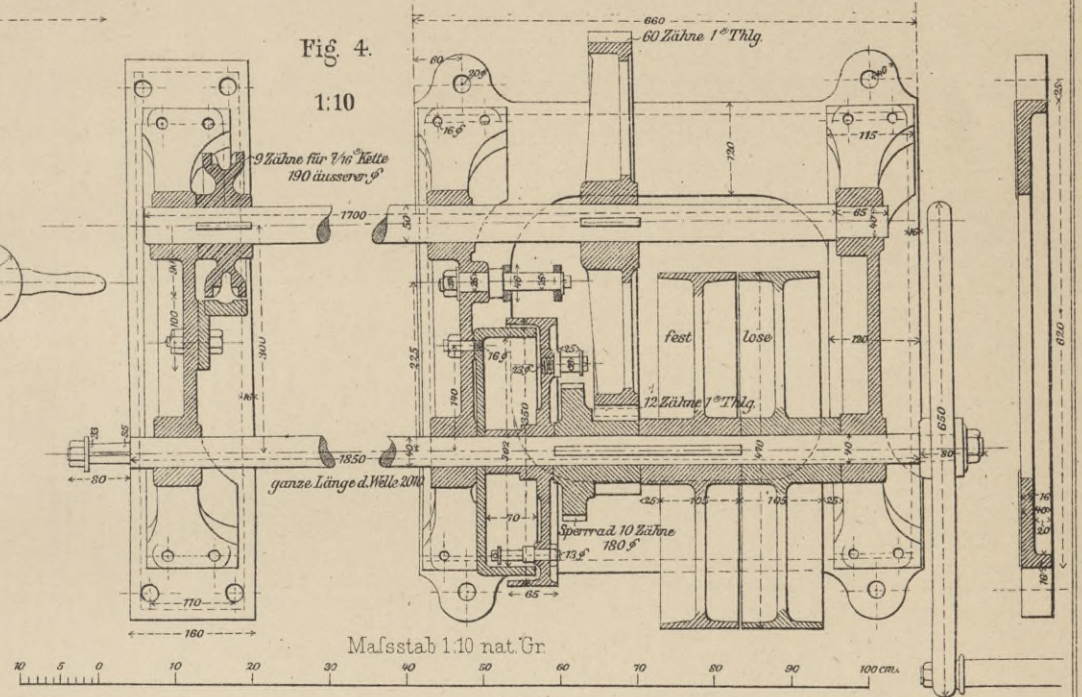

Dampfwinde  
von  
Corradi.

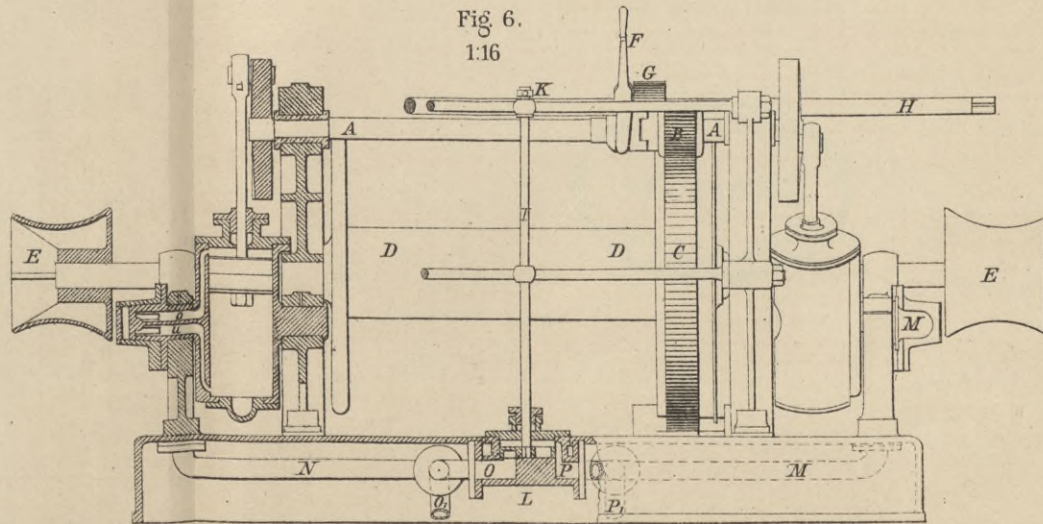

Mafsstab 1:16 nat. Gr.

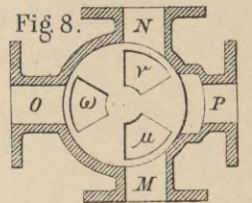
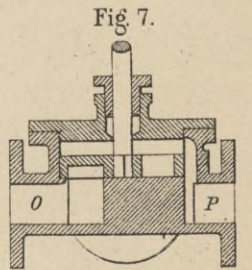
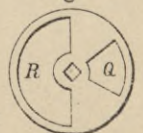

Fig. 9.



6 Fuss. engl.







Dampfwinde  
von  
Emmerson, Walker & Co

Fig. 2.

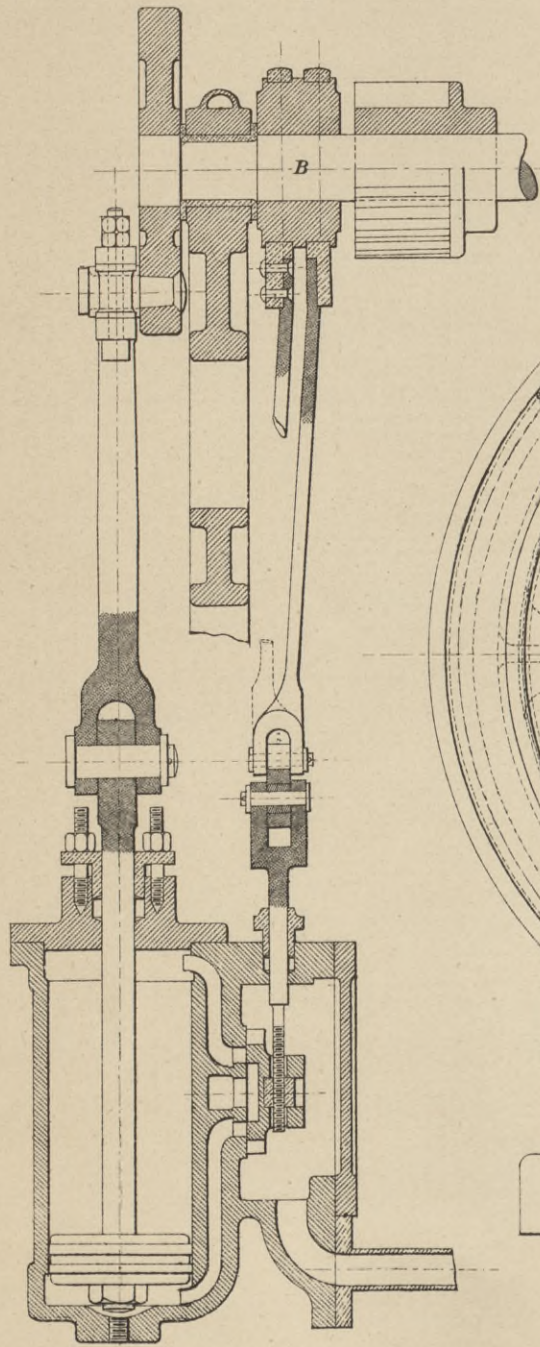

Fig. 1.

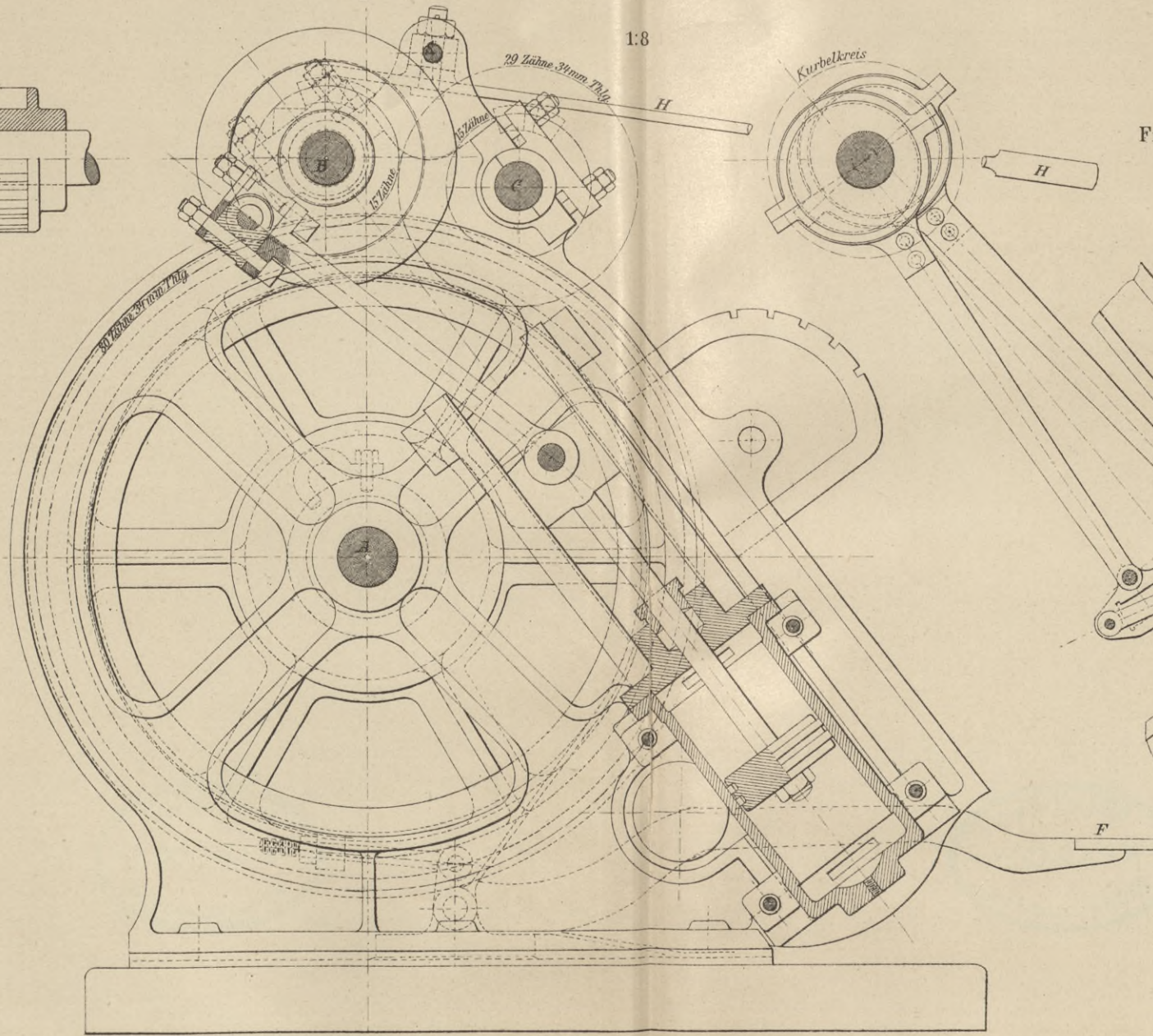
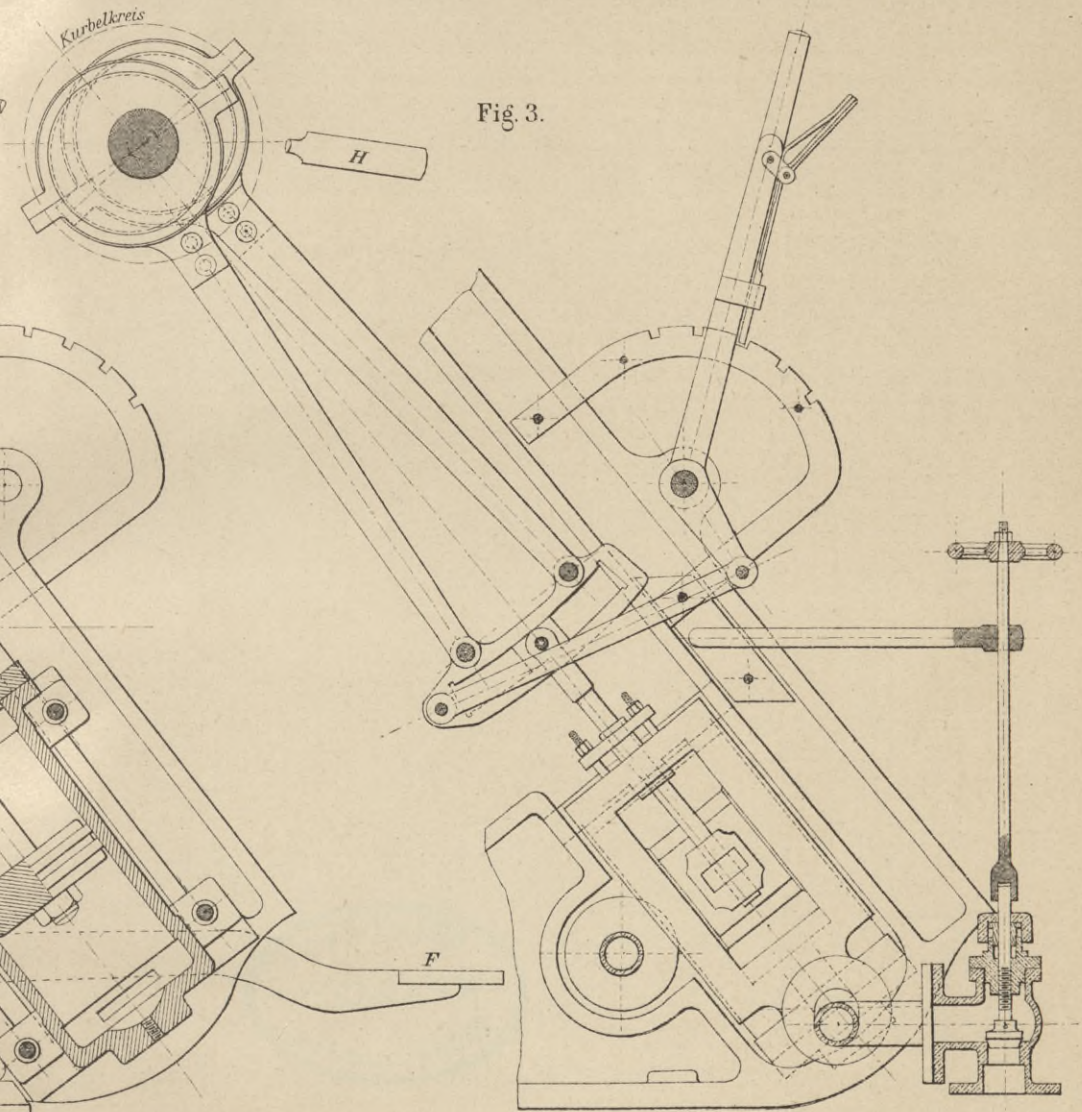
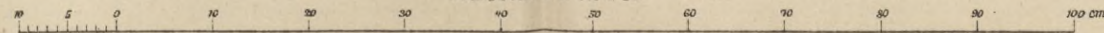

Fig. 3.



Mafsstab 1:8 nat. Gr







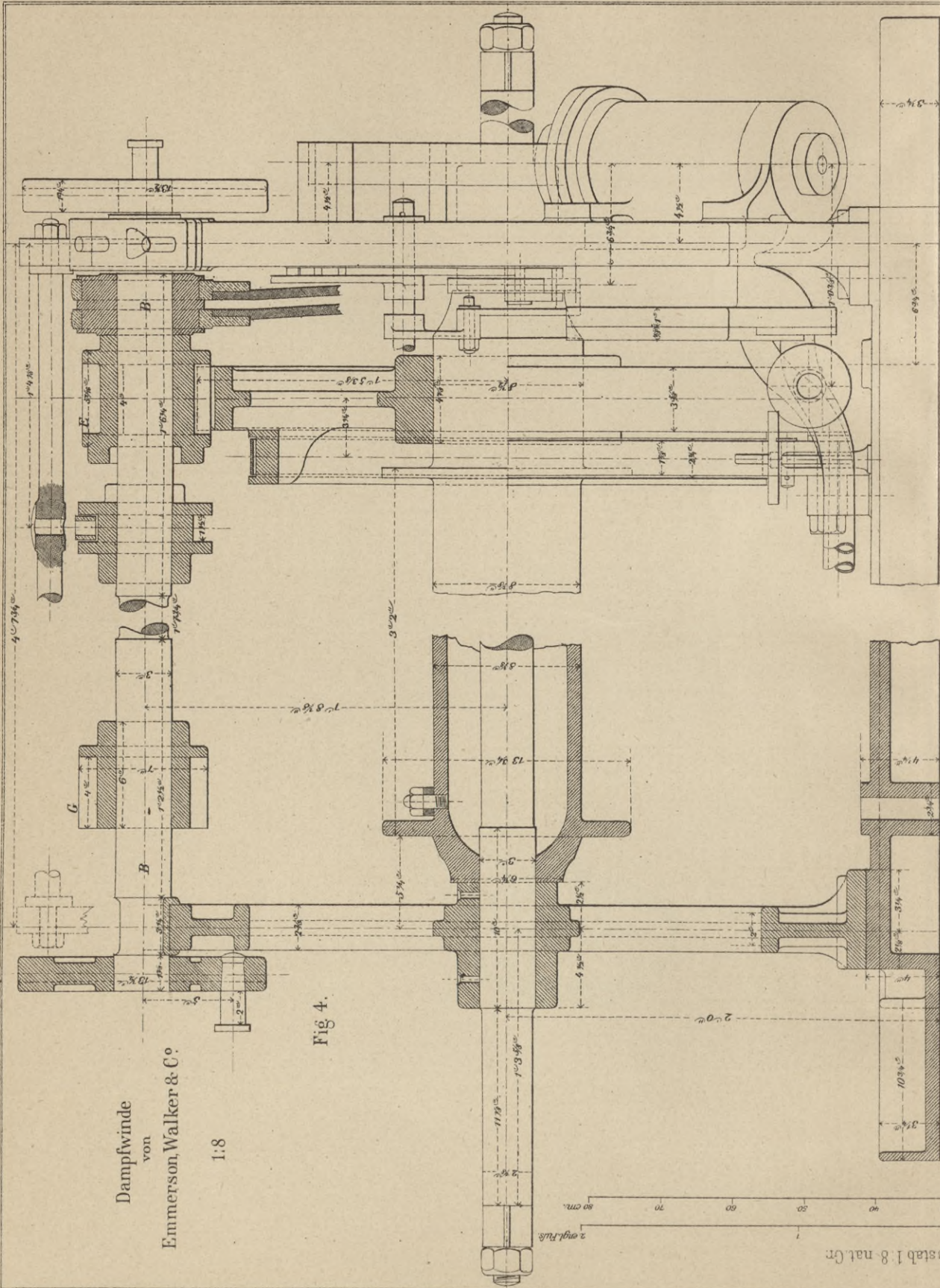

Fig. 4.

Dampfwinde  
von  
Emmerson, Walker & Co  
1:8

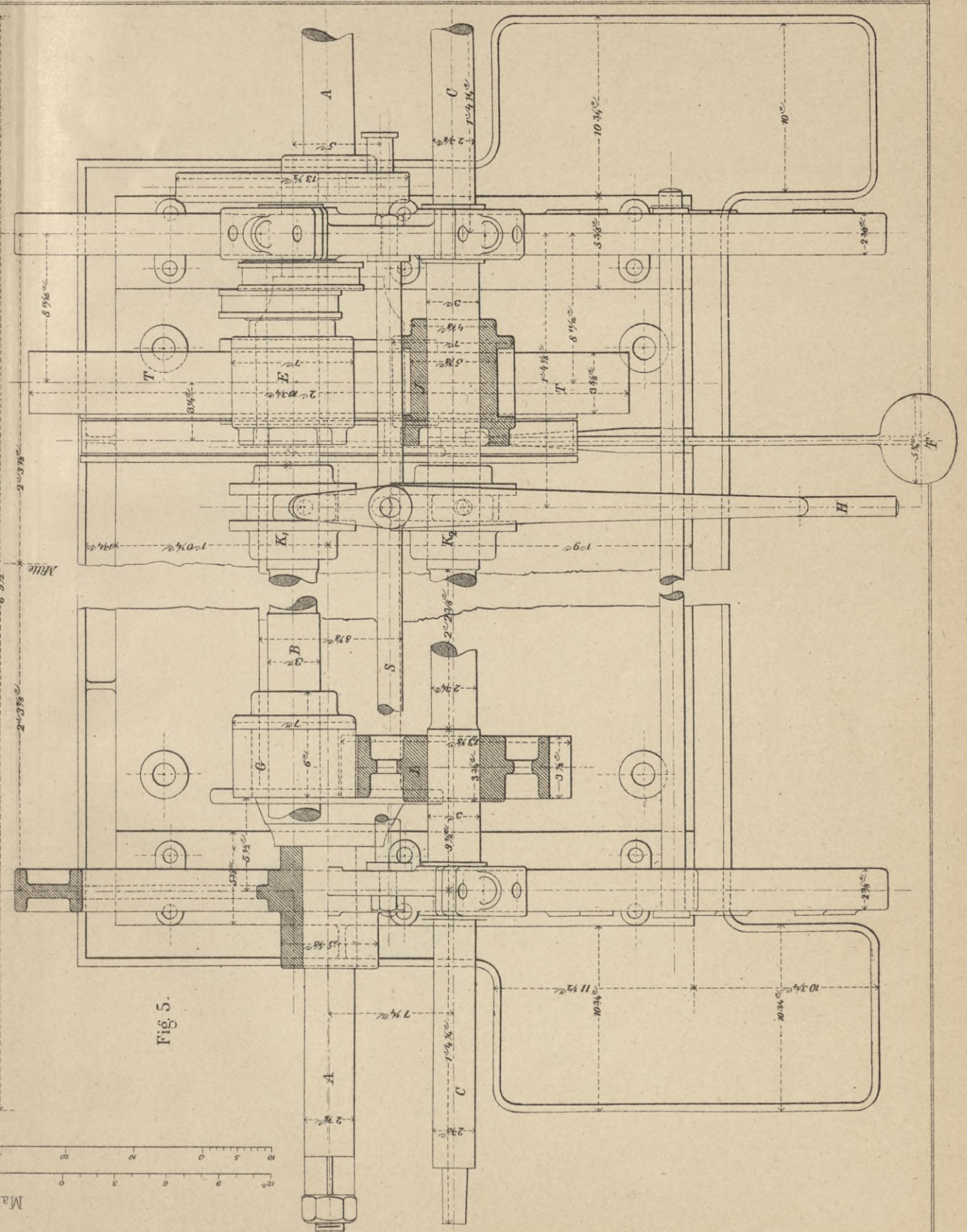
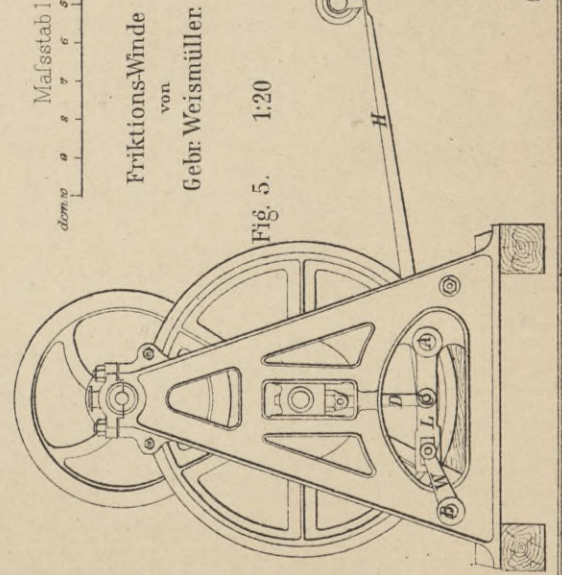
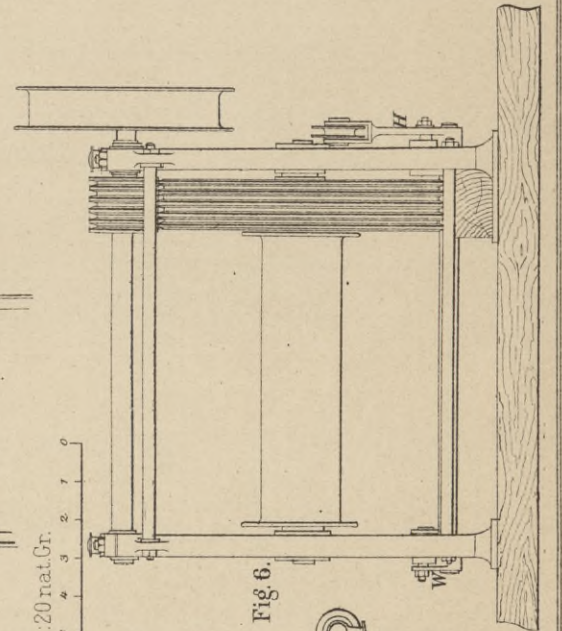
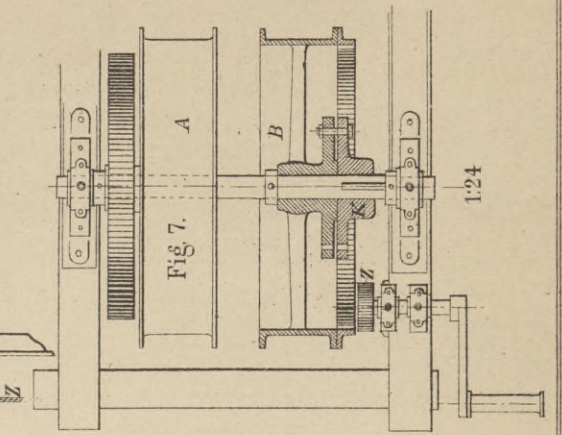
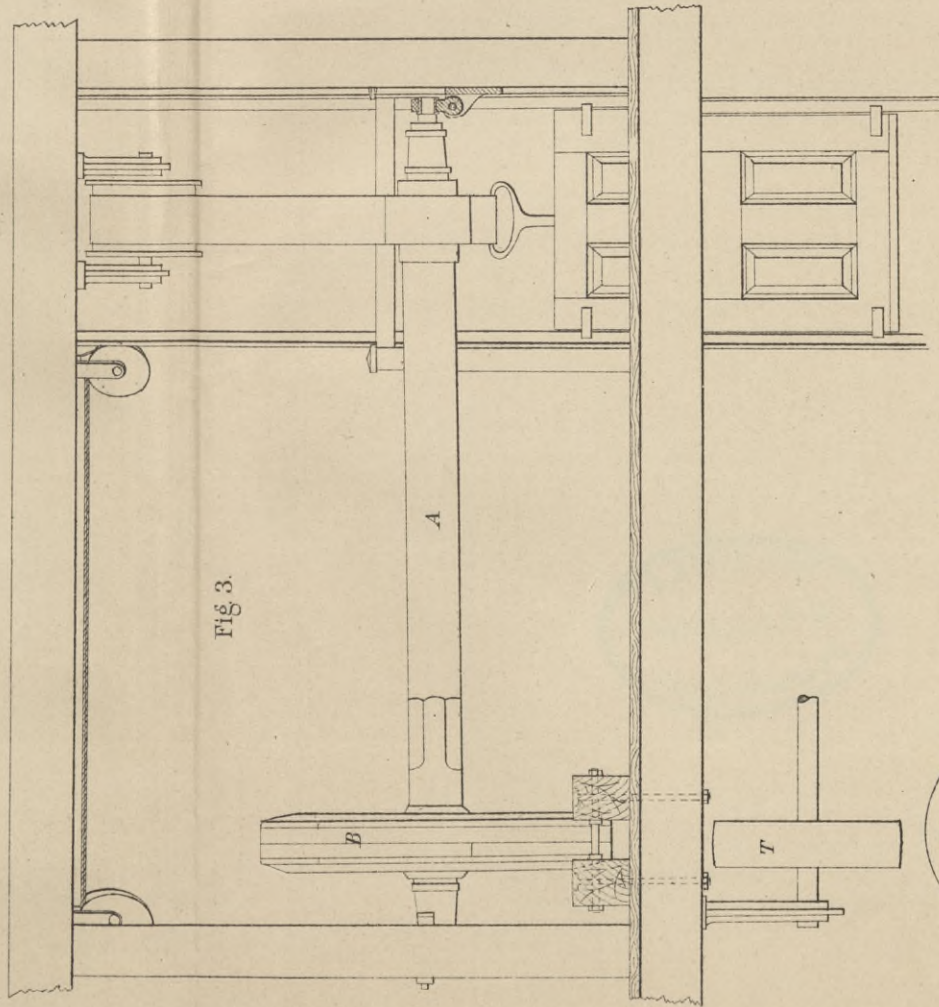
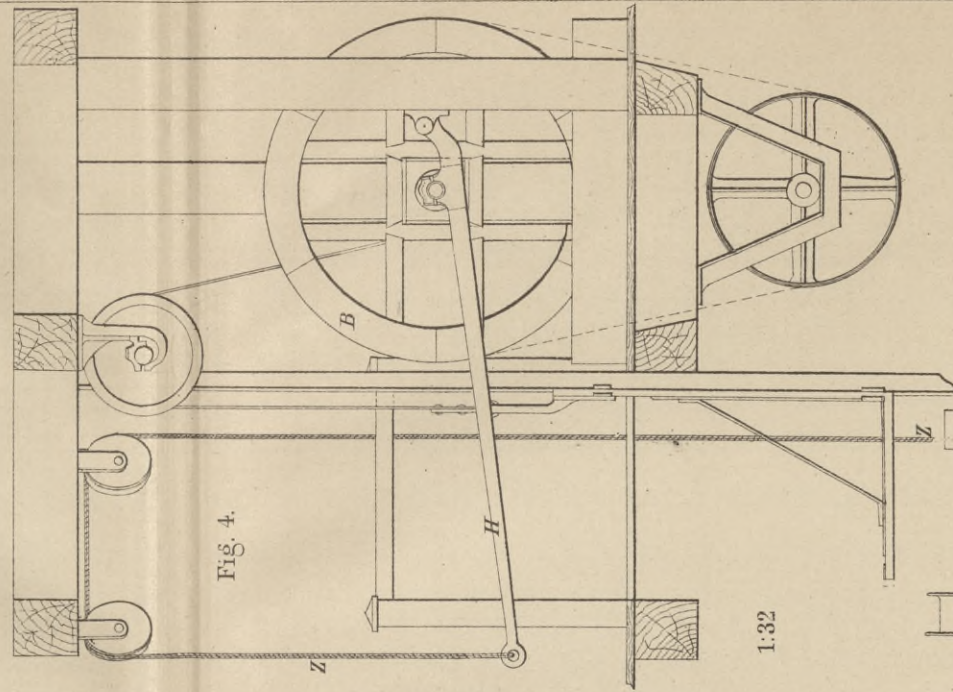
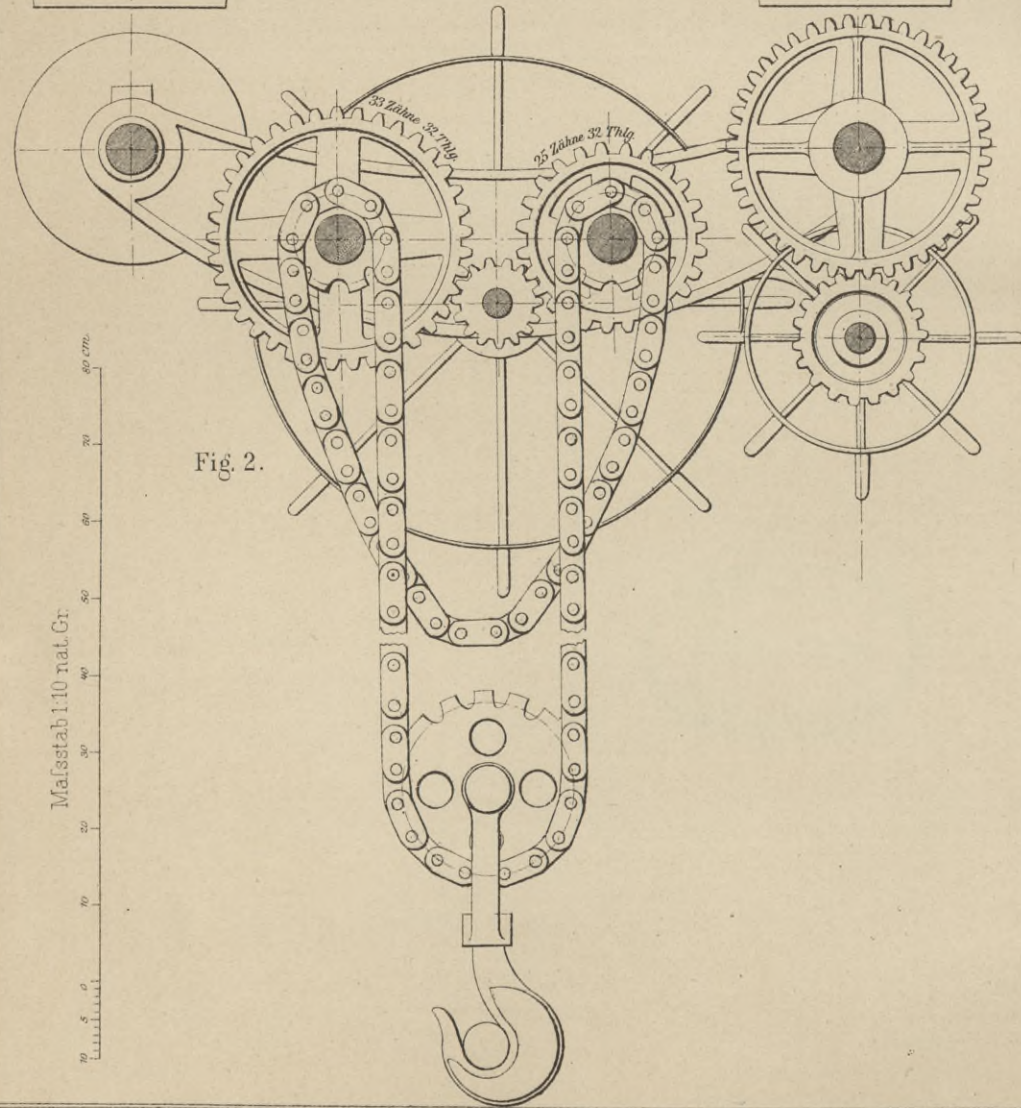
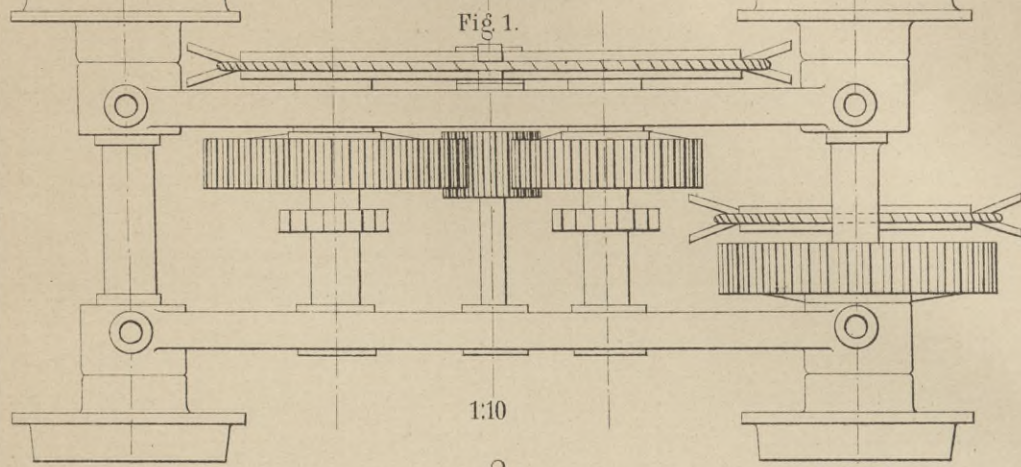

Fig. 5.





Krahn-Laufkatze  
von  
Zobel, Neubert & Co  
in Schmalkalden.



Friktions-Winde  
von  
Gebr. Weismüller.







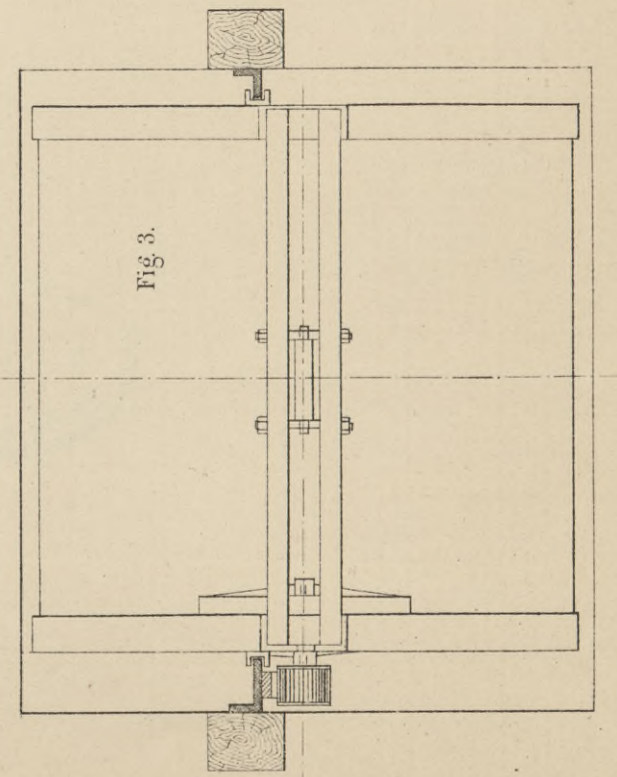
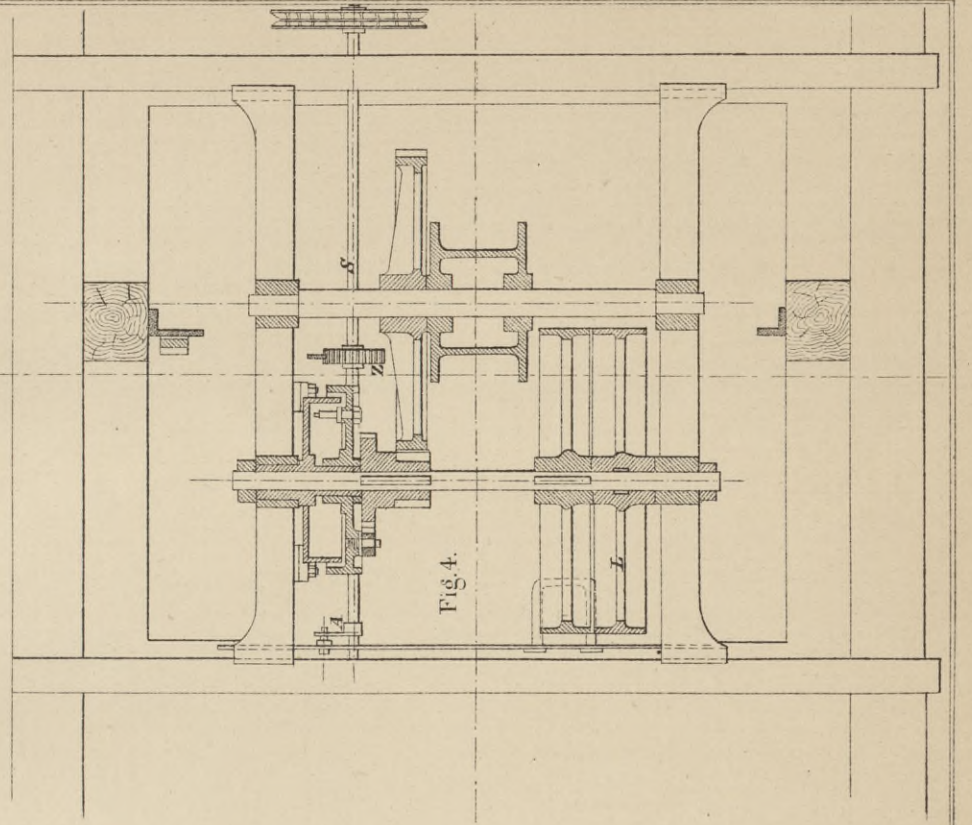
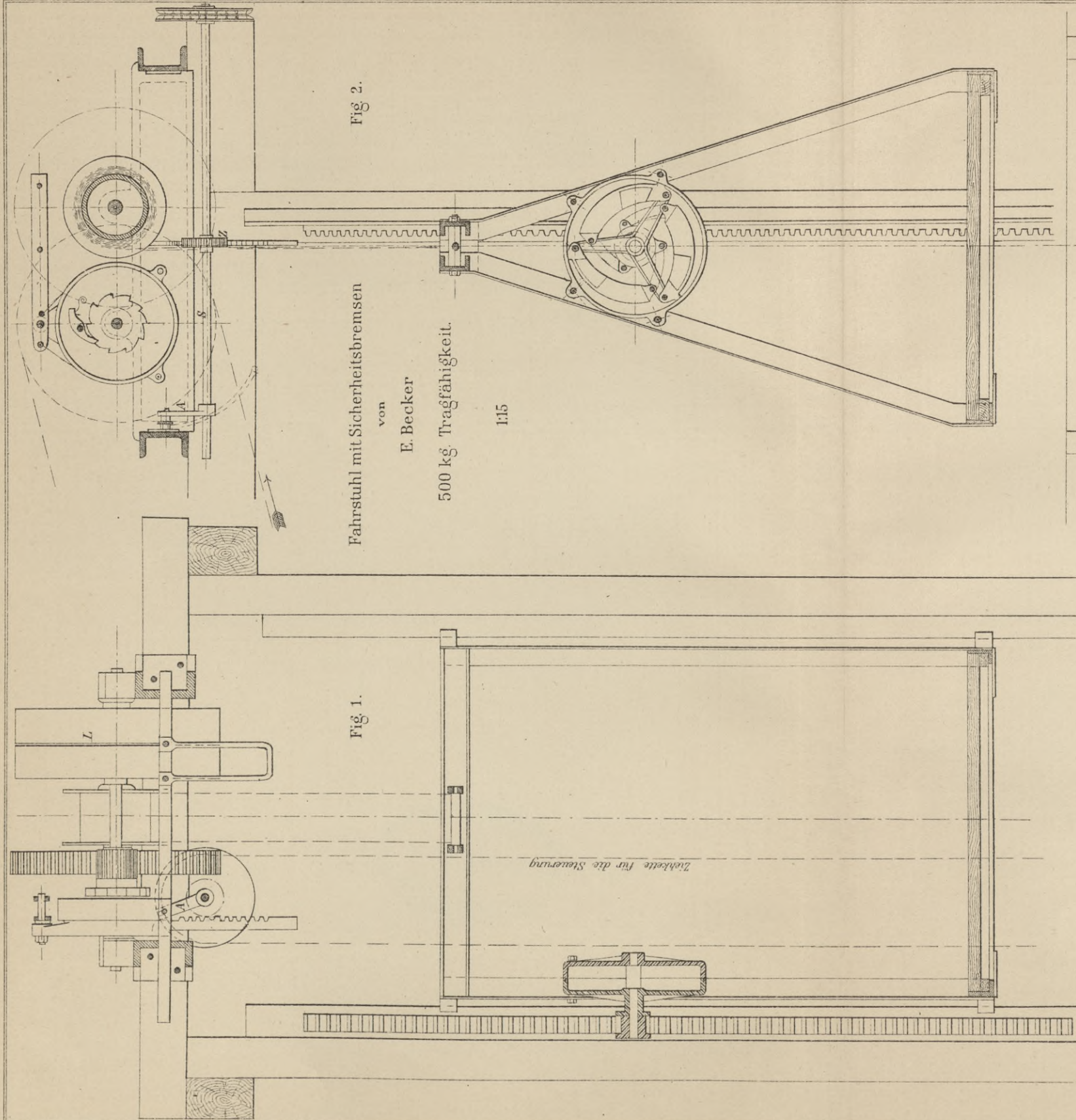

Maßstab 1:15 nat. Gr.  
0 1 2 3 4 5 6 7 8 9 10  
dm





Fahrstuhl,  
zu  
Konstruktion der gräflich Stolberg'schen Maschinenfabrik  
Jlsenburg.

Fig. 1.

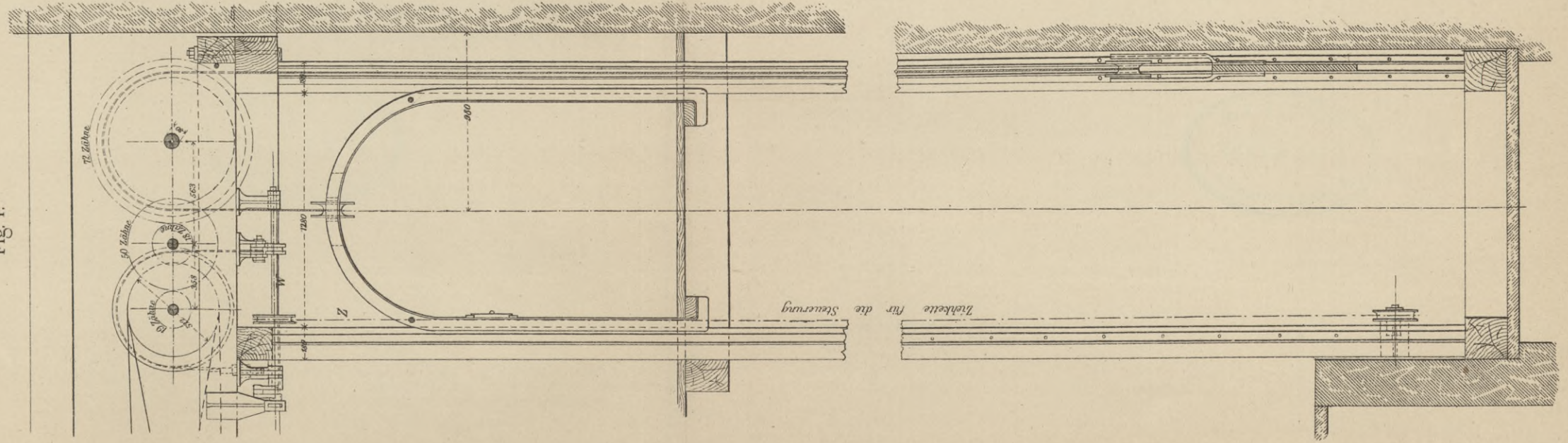
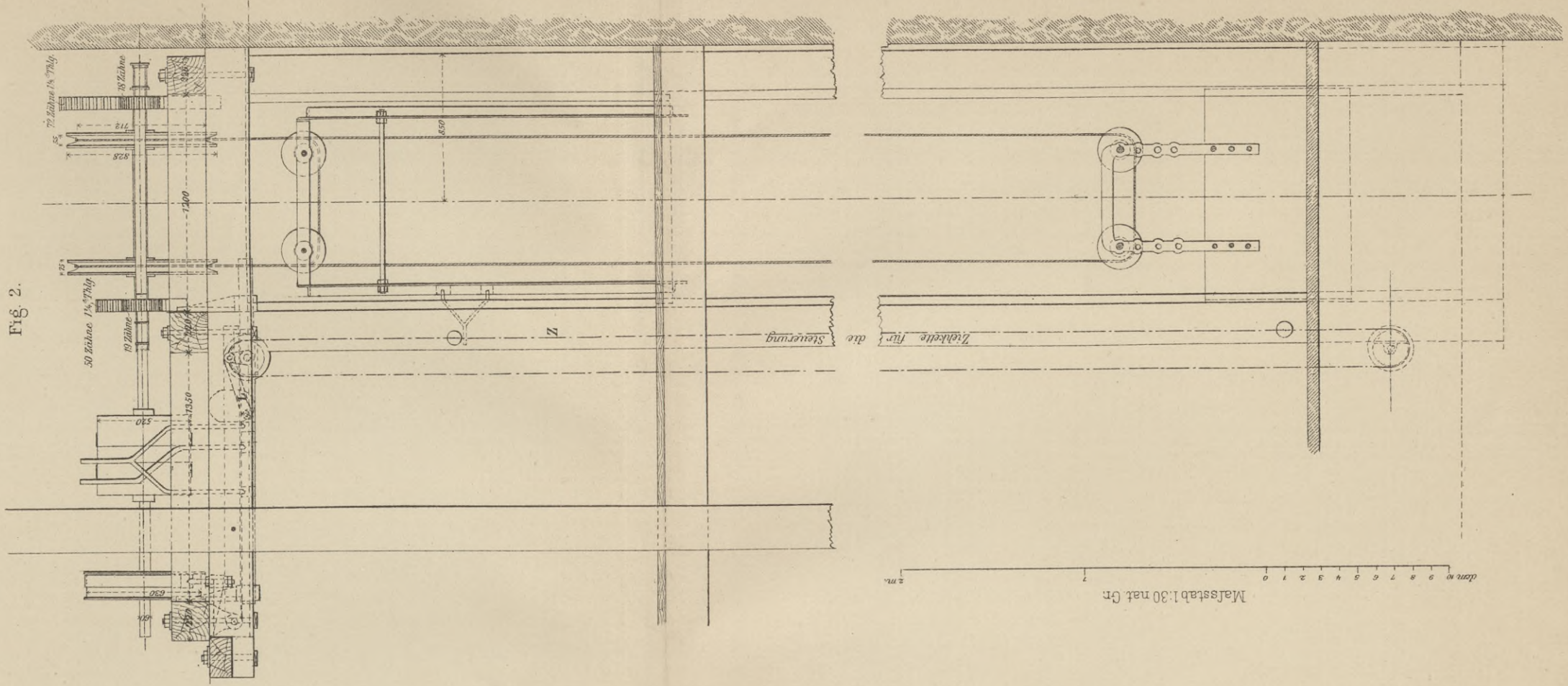

Fig. 2.









Aktenaufzug im neuen Rathhause zu Berlin.

Fig. 1.  
Windebock.

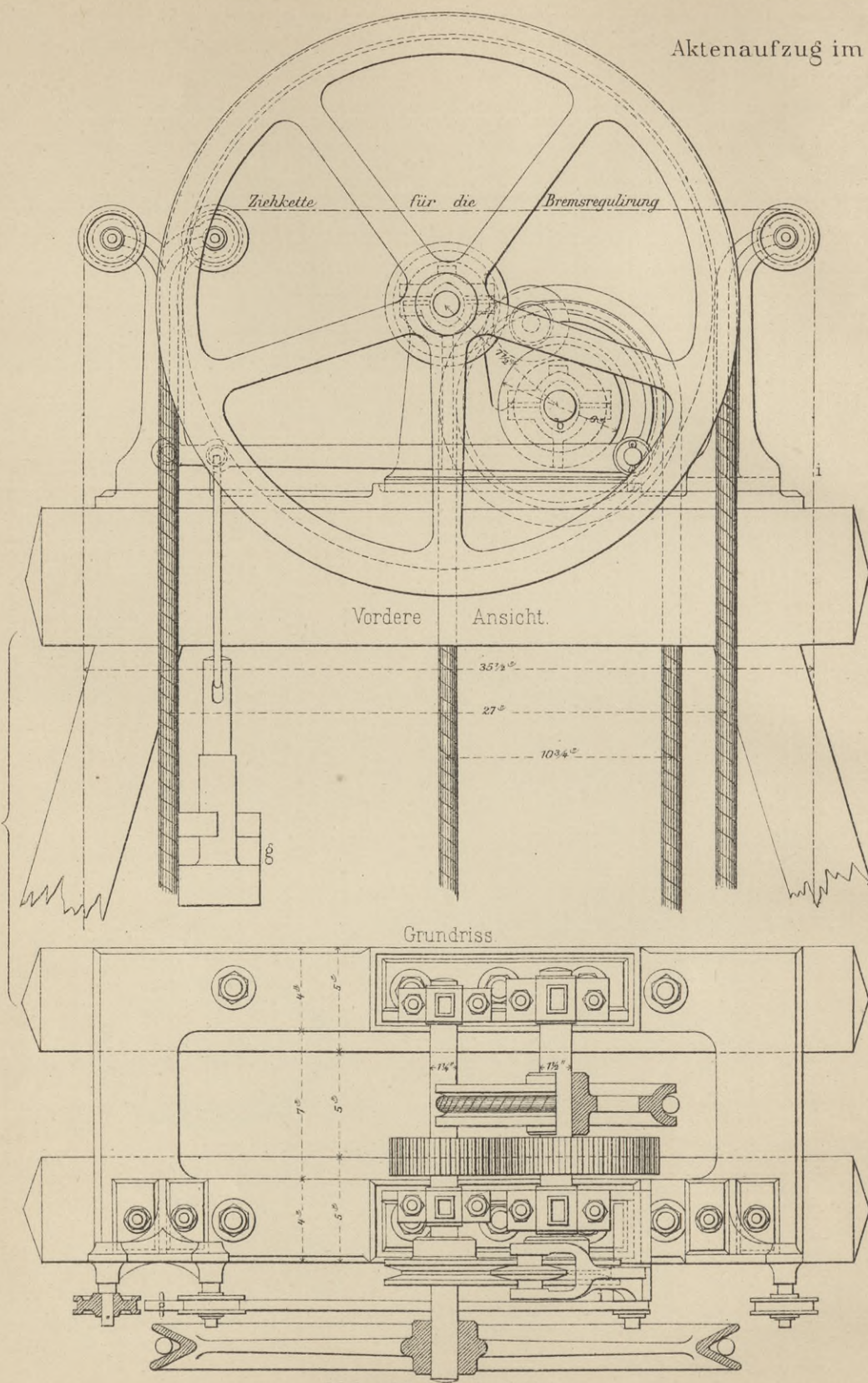

Mafsstab 1:8 nat. Gr. Fig. 1-4.

2 Fuss rh.

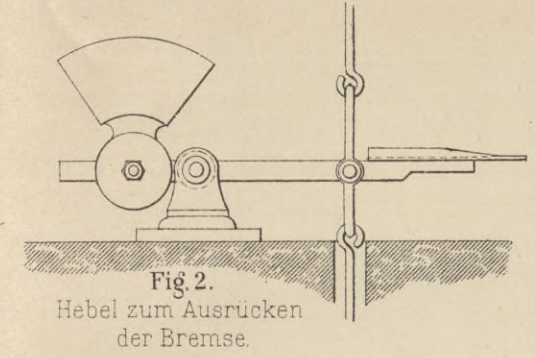
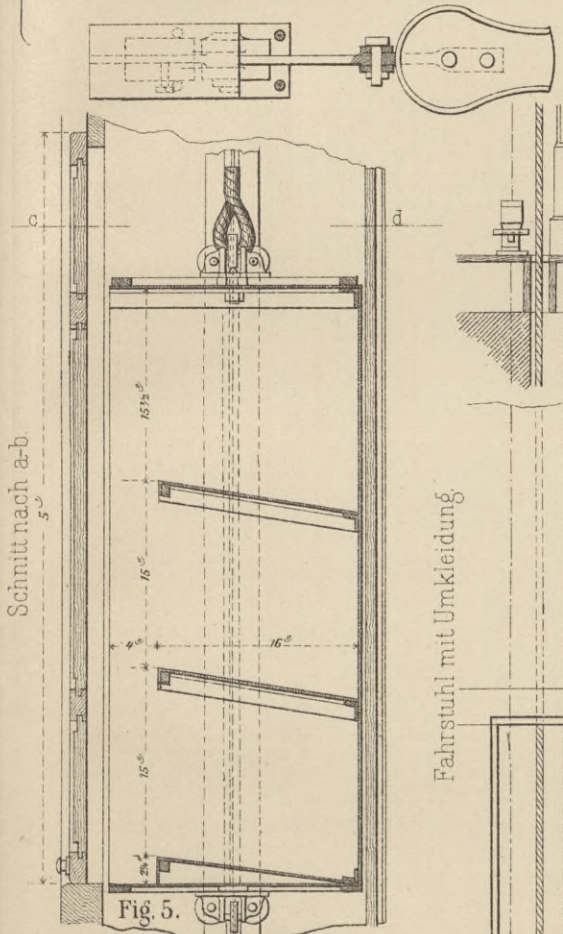

Fig. 2.  
Hebel zum Ausrücken  
der Bremse.



Schnitt nach a-b.

Schnitt nach c-d.

Fig. 5.

Fahrstuhl mit Umkleidung

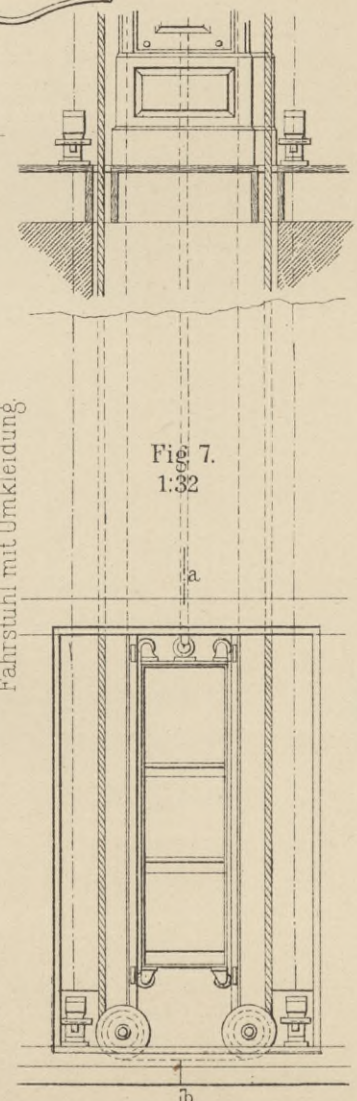

Fig. 7.  
1:32

Mafsstab 1:16 nat. Gr. Fig. 5 u. 6.

12 9 6 3 0 1

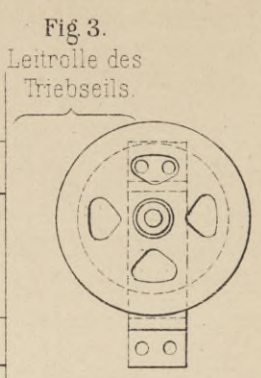

Fig. 3.  
Leitrolle des  
Triebseils.

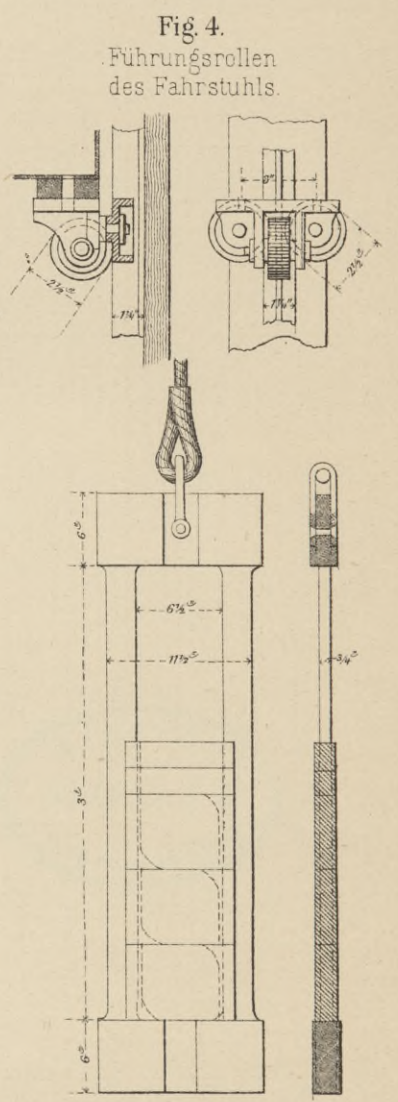

Fig. 4.  
Führungsrollen  
des Fahrstuhls.

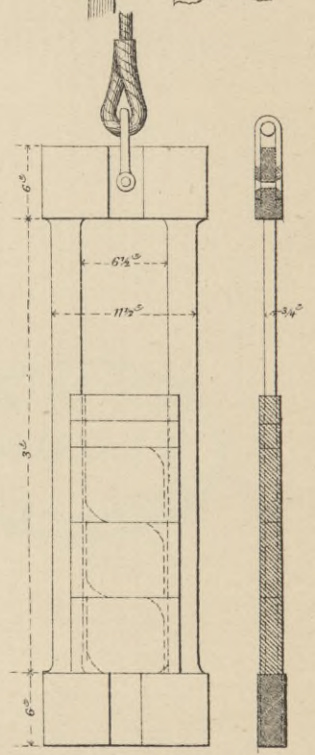

Fig. 6.  
Gegengewicht.

3 Fuss rh.





### Hydraulischer Gichtaufzug von James Farmer in Manchester:

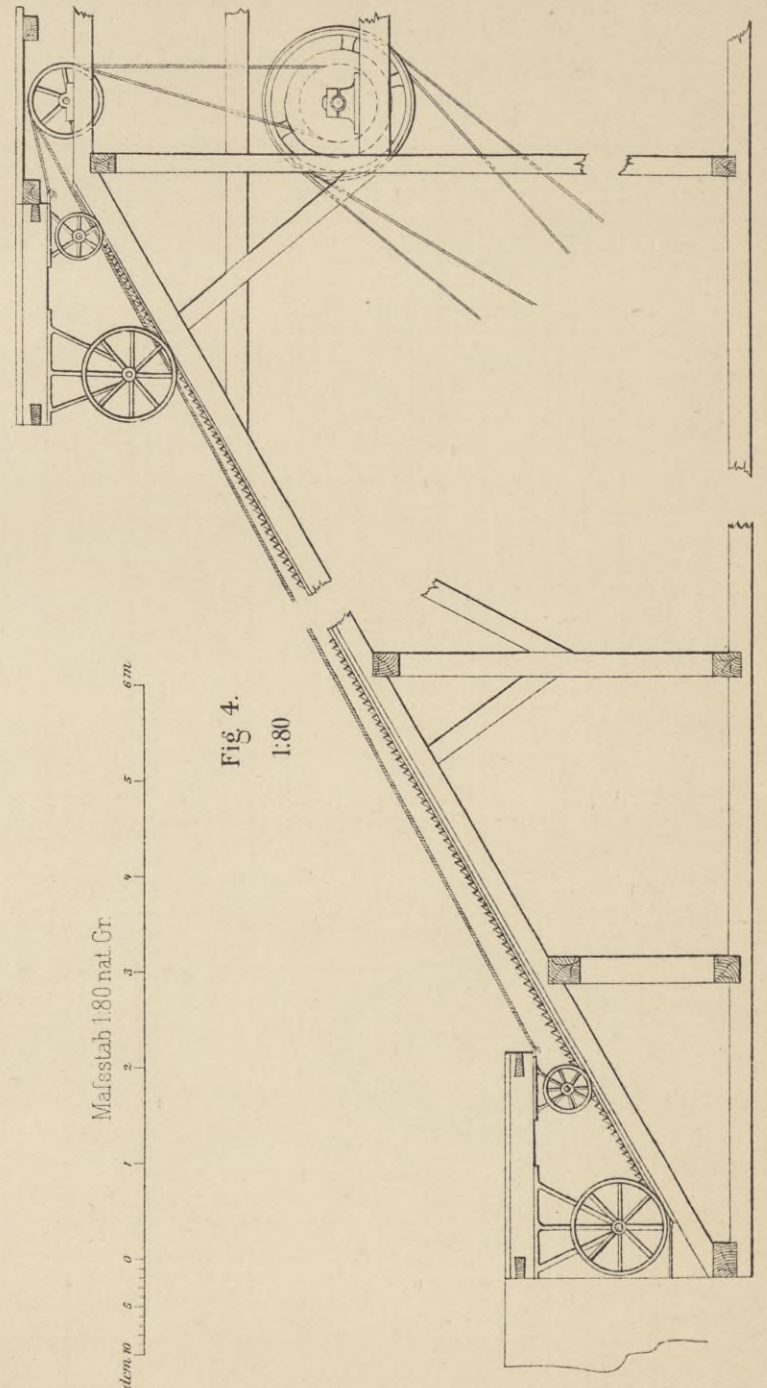
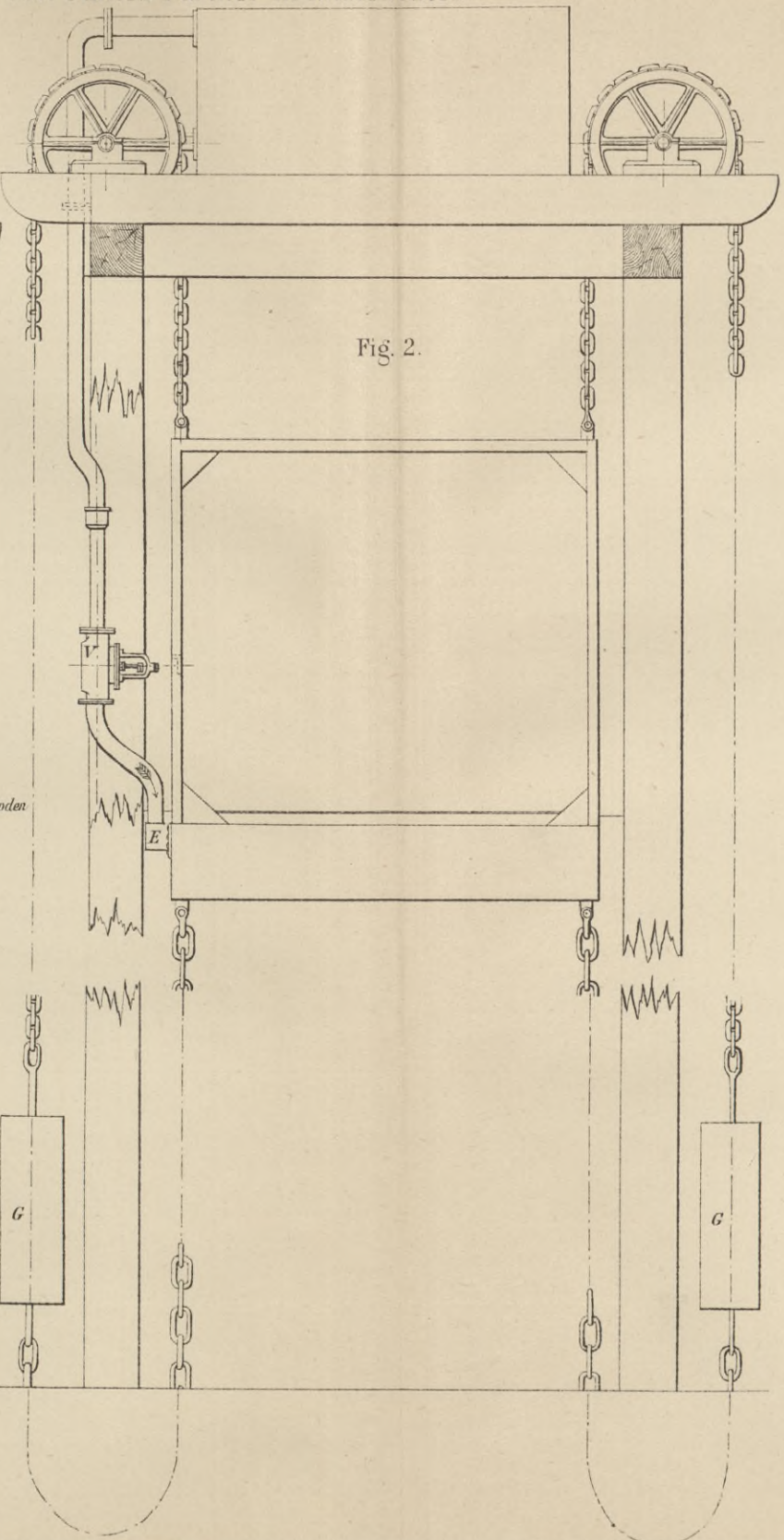
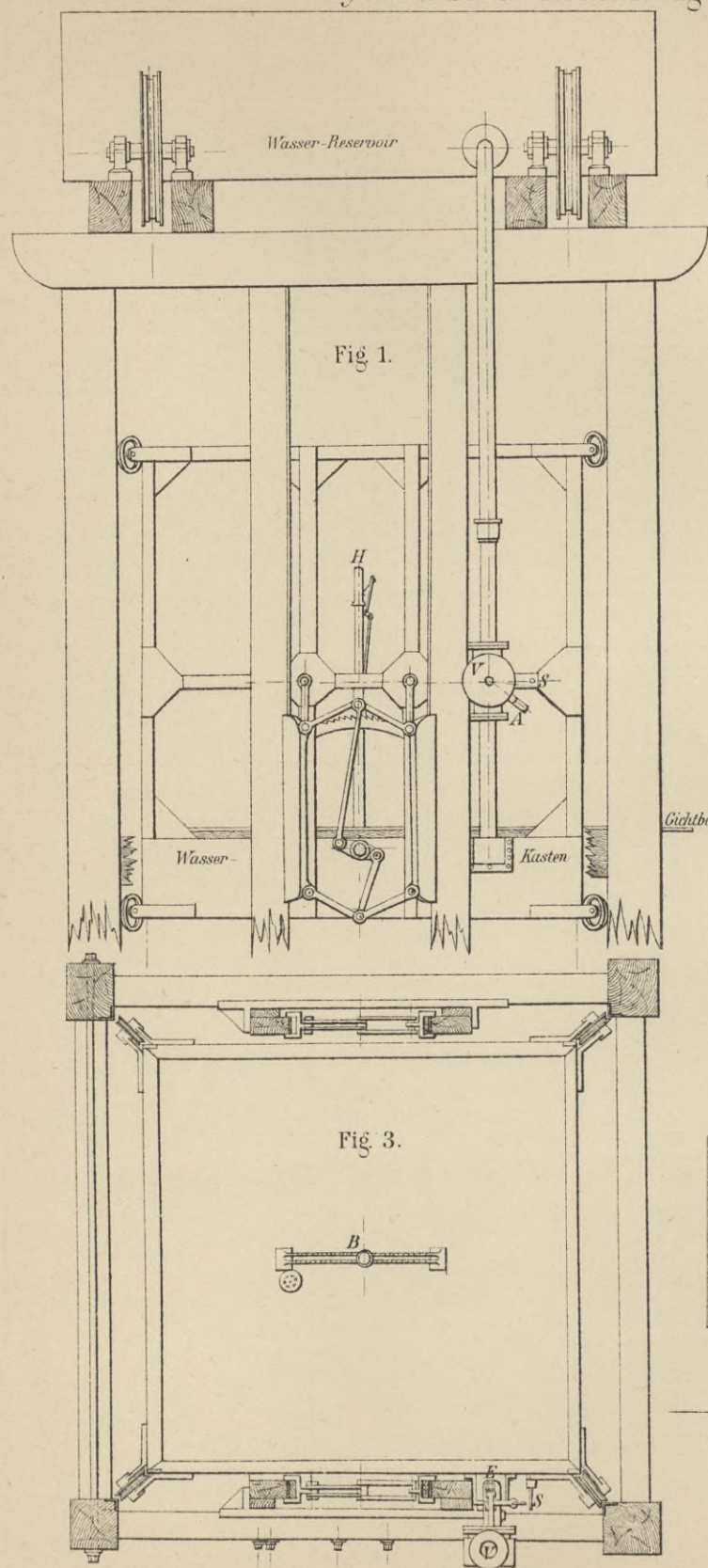
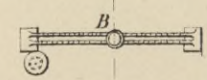

Fig. 3.







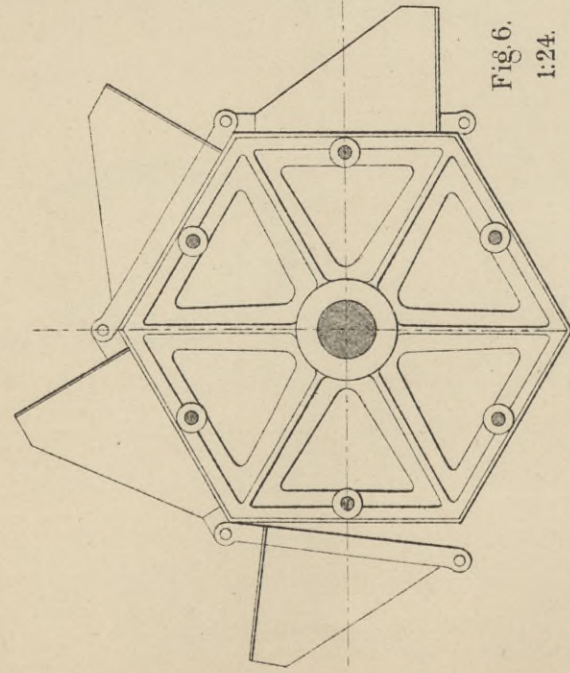

Fig. 6.  
1:24.

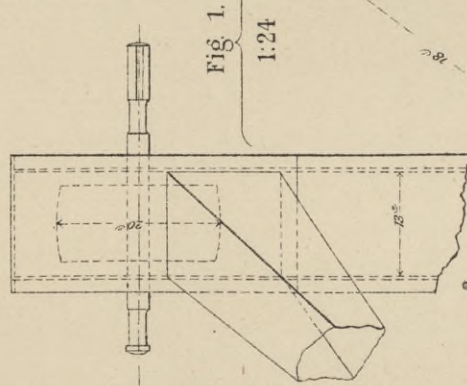

Fig. 1.  
1:24.

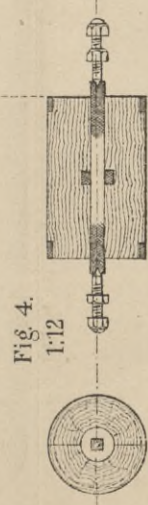
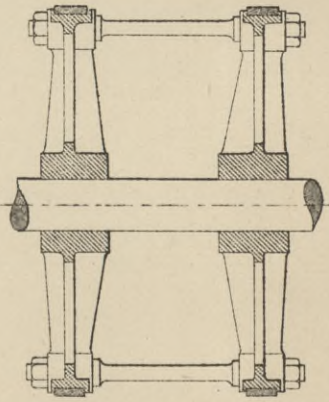

Fig. 4.  
1:12.

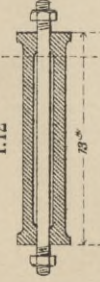

Fig. 5.  
1:12.

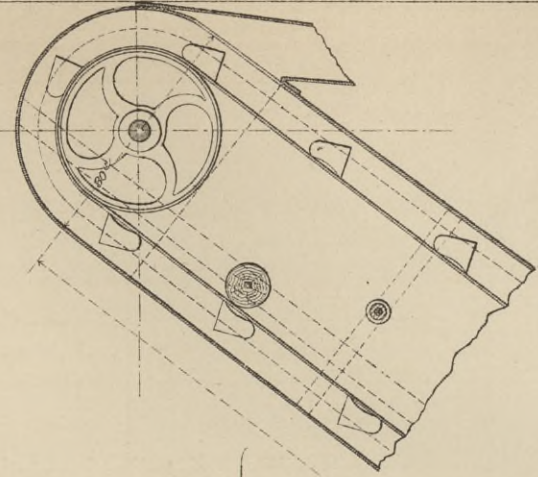

Fig. 2.  
1:12.

Schnitt nach a-b

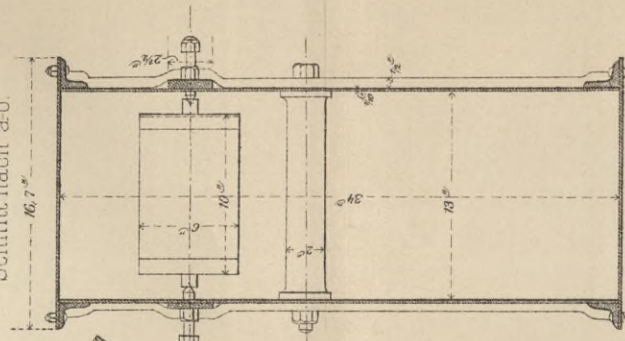

Fig. 2.  
1:12.

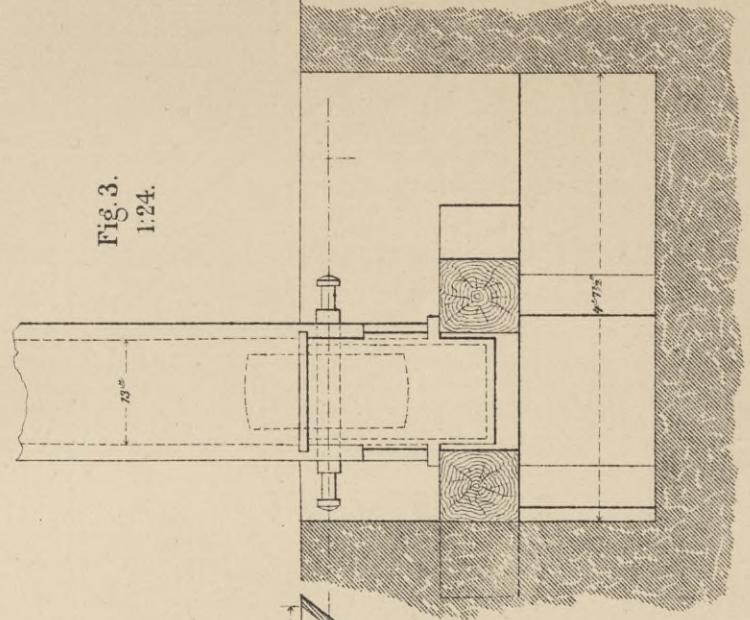
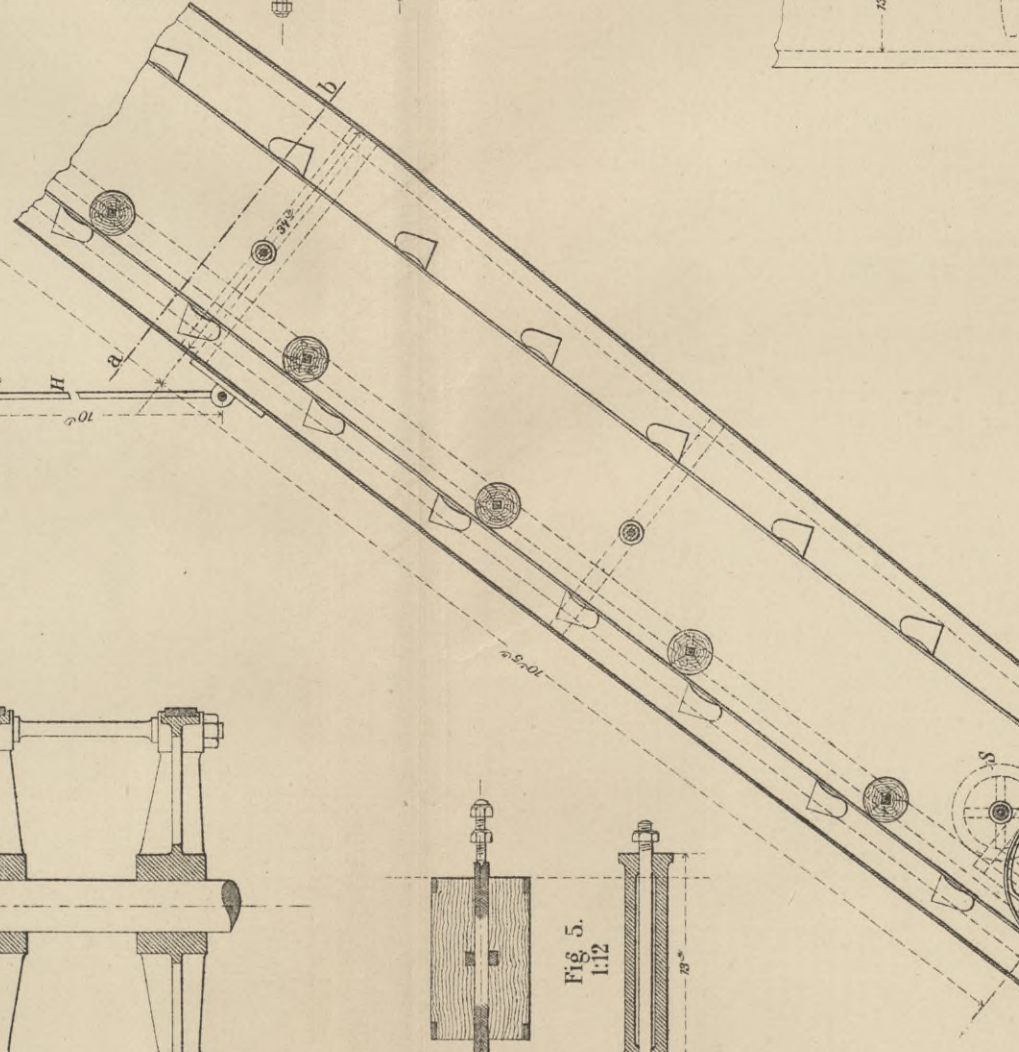
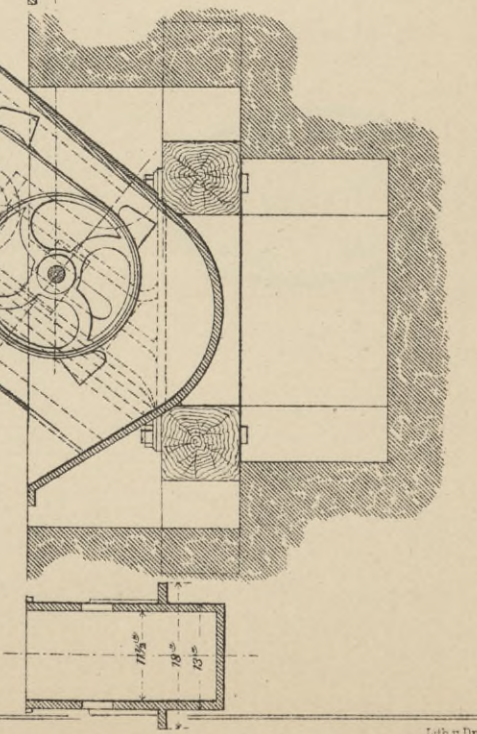
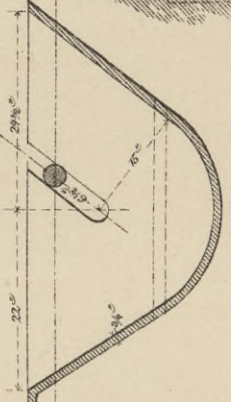
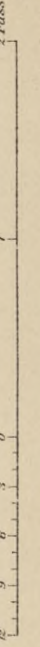
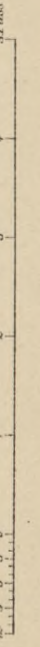

Fig. 3.  
1:24.



Maisstab 1:24 nat. Gr.

Maisstab 1:12 nat. Gr.









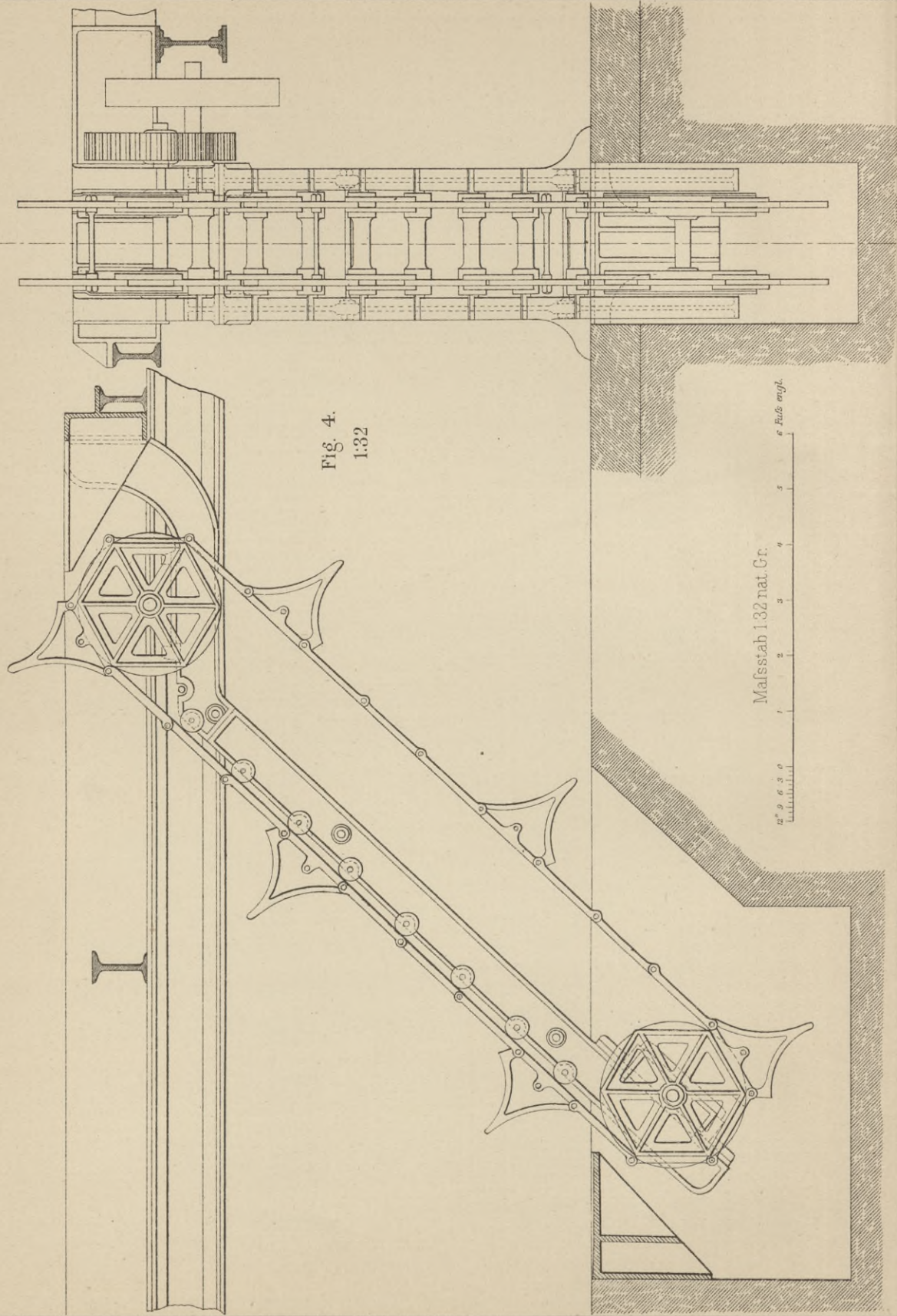

Fig. 4.  
1:32

Maßstab 1:32 nat. Gr.  
1 2 3 4 5 6 Fuß engl.

Kipp-Becherwerk  
 von  
 M. Neuerung in Köln.  
 1:10  
 D.R.P. N<sup>o</sup> 13632.

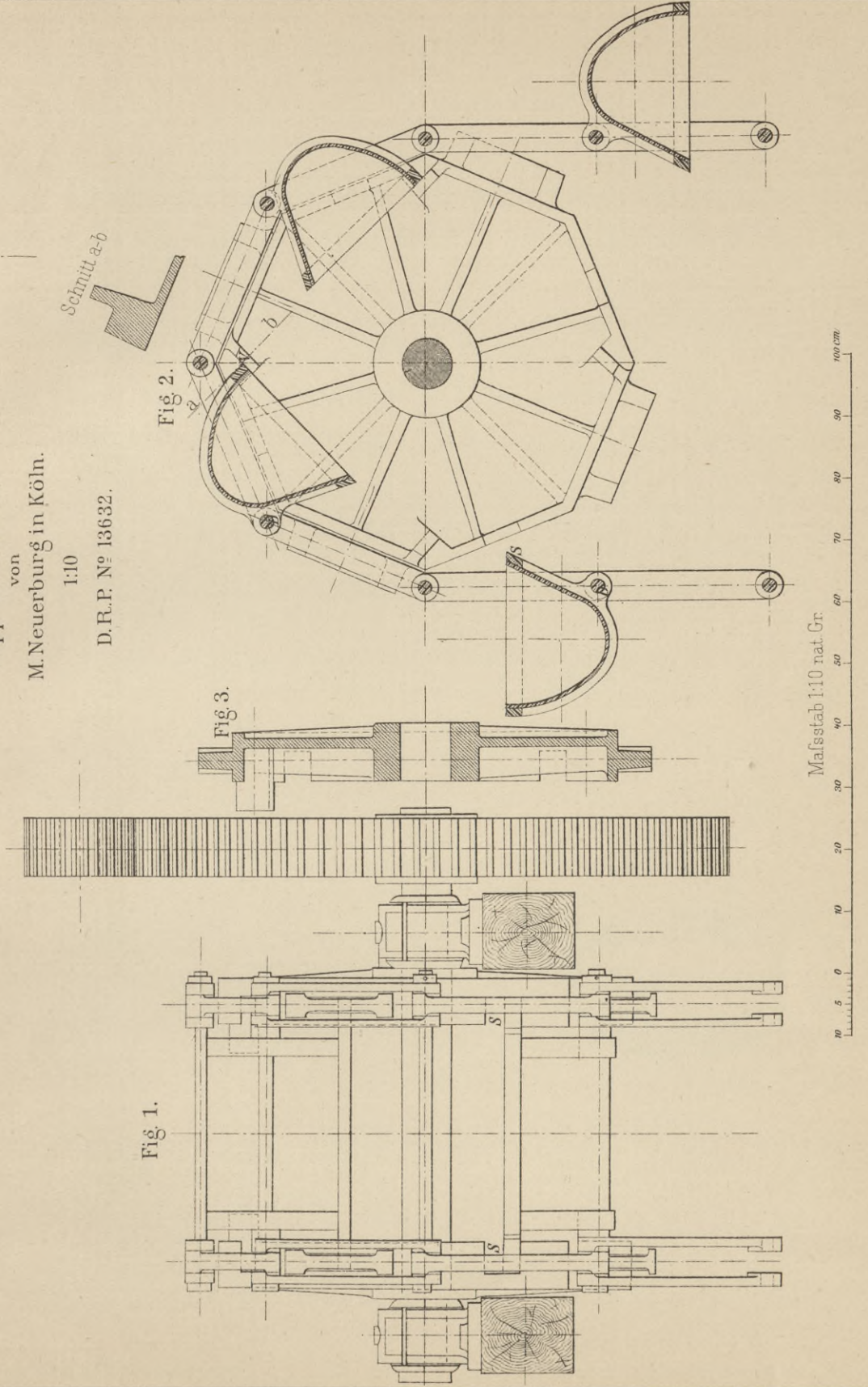

Fig. 1.

Fig. 3.

Fig. 2.

Schnitt a-b

Maßstab 1:10 nat. Gr.  
0 10 20 30 40 50 60 70 80 90 100 cm





Uferkrahne von E. Becker,  
für 3000 kg Last an der losen Rolle.  
4,5m Ausladung.

Fig. 1.  
1:10

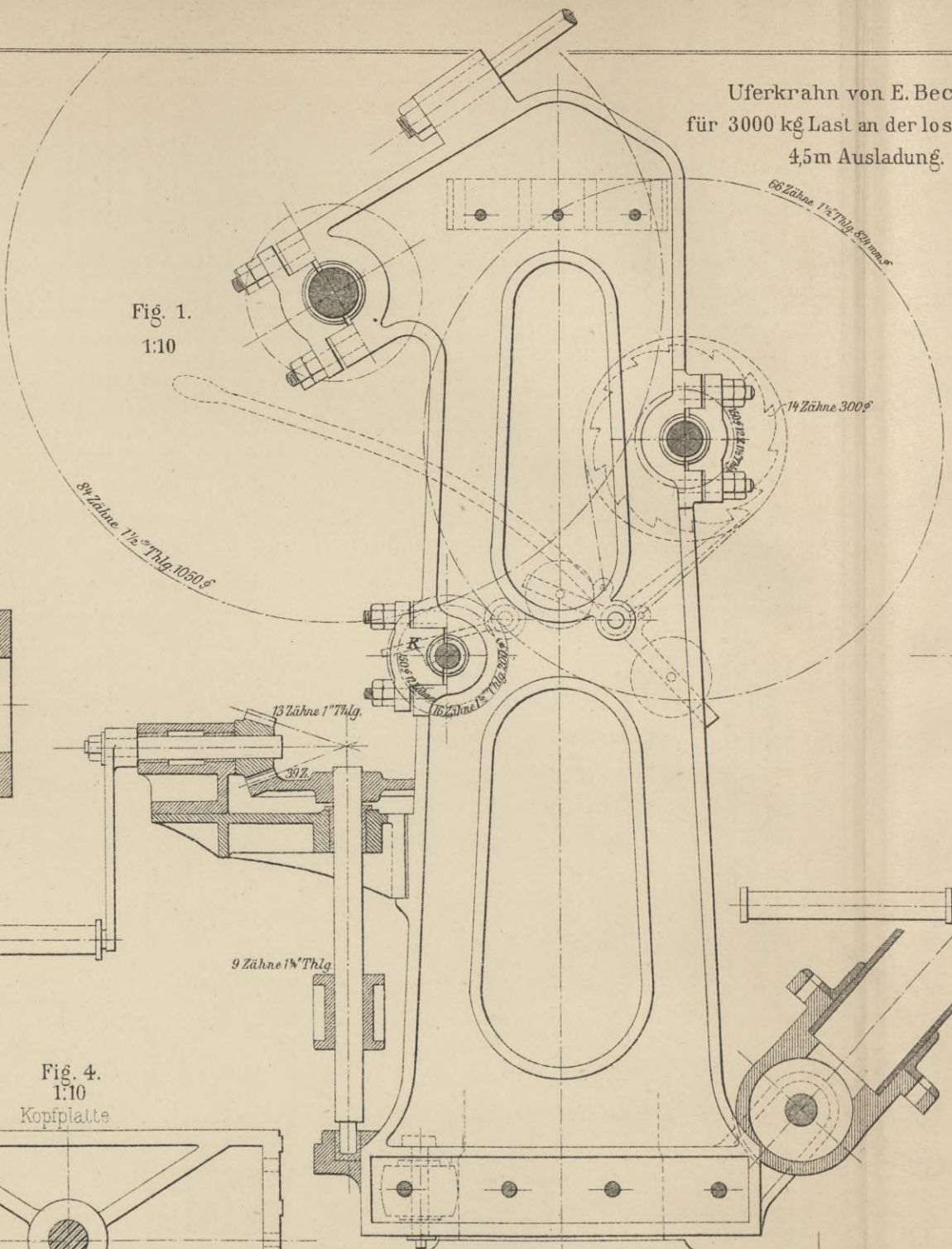

Fig. 2.  
1:10

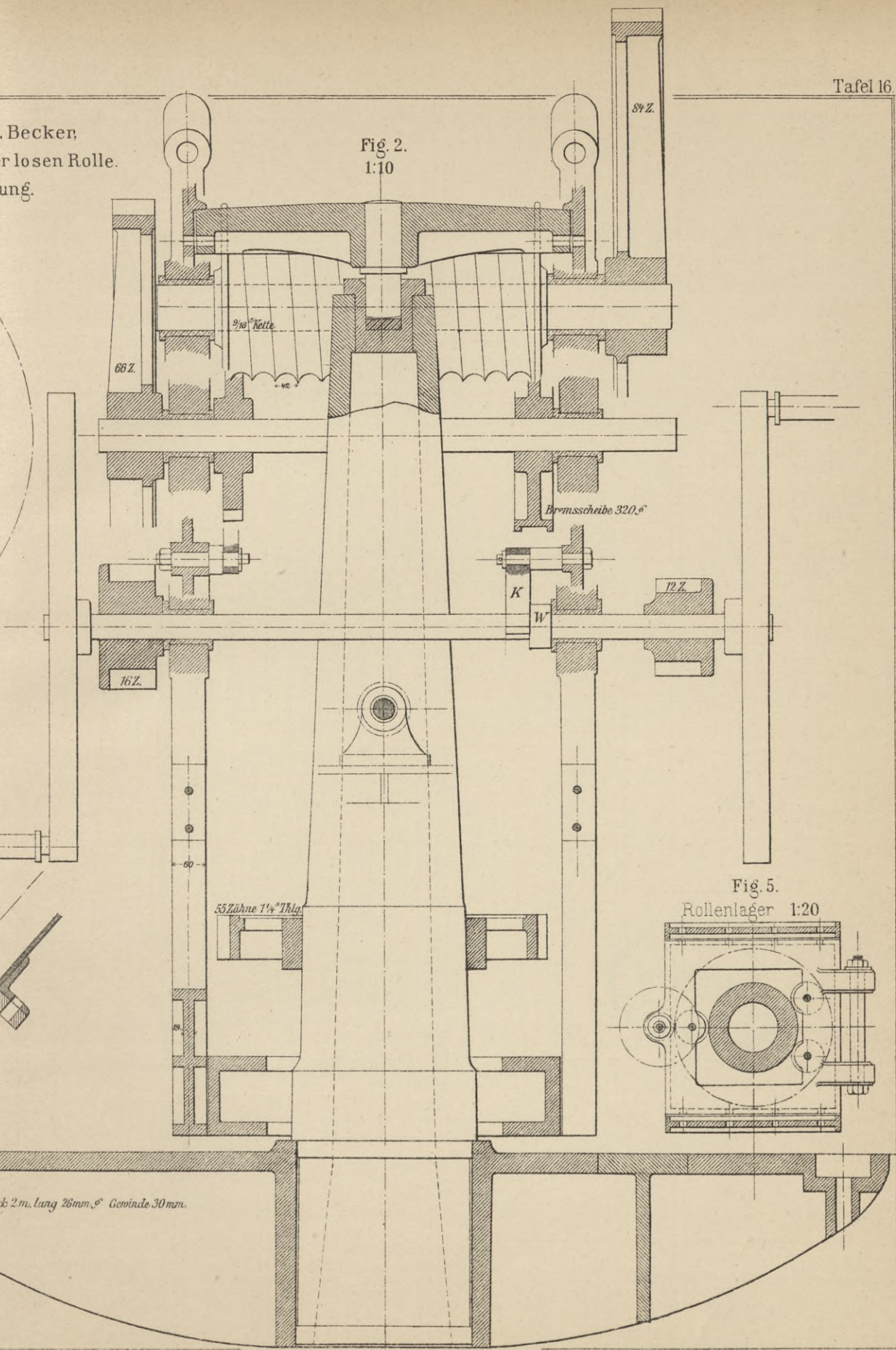

Fig. 3.  
1:10  
Auslegerschuh.

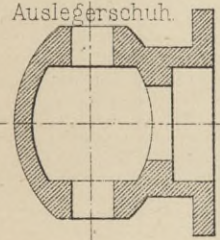

Fig. 4.  
1:10  
Kopfplatte

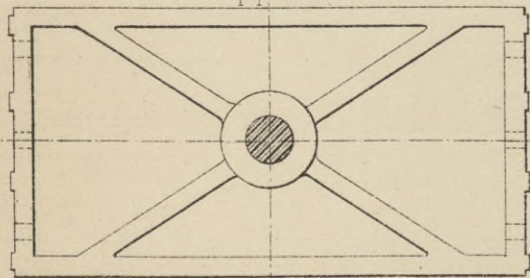
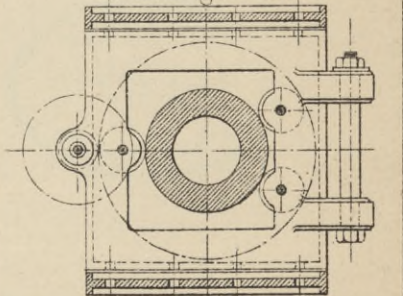
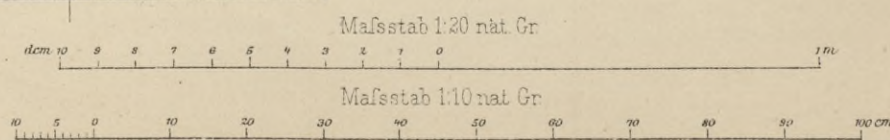

Fig. 5.  
Rollenlager 1:20



Anker 8 Stück 2 m. lang 26 mm. Gewinde 30 mm.







Krahn von E. Becker  
1000 kg Last, 3m. Ausladung.

1:20

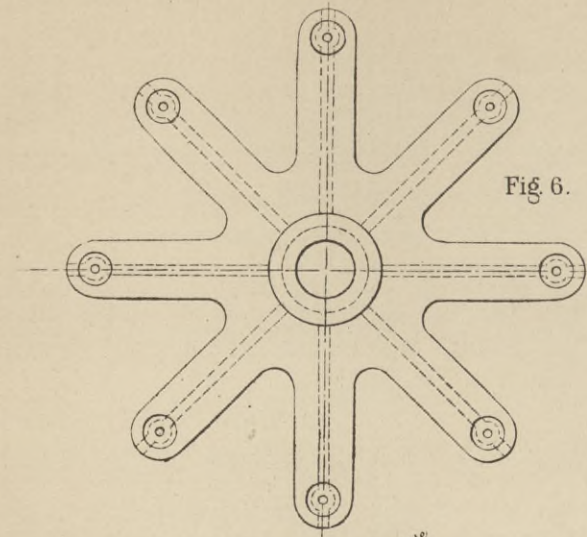

Fig. 6.

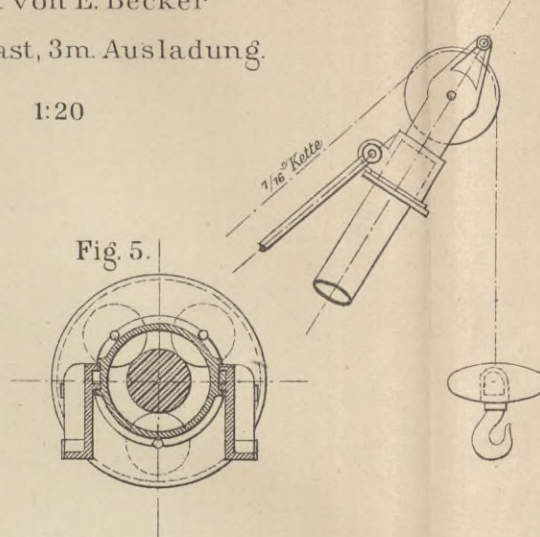

Fig. 5.

Auslegerkopf zum 30 Ctr. Krahn.

Fig. 1.  
1:10

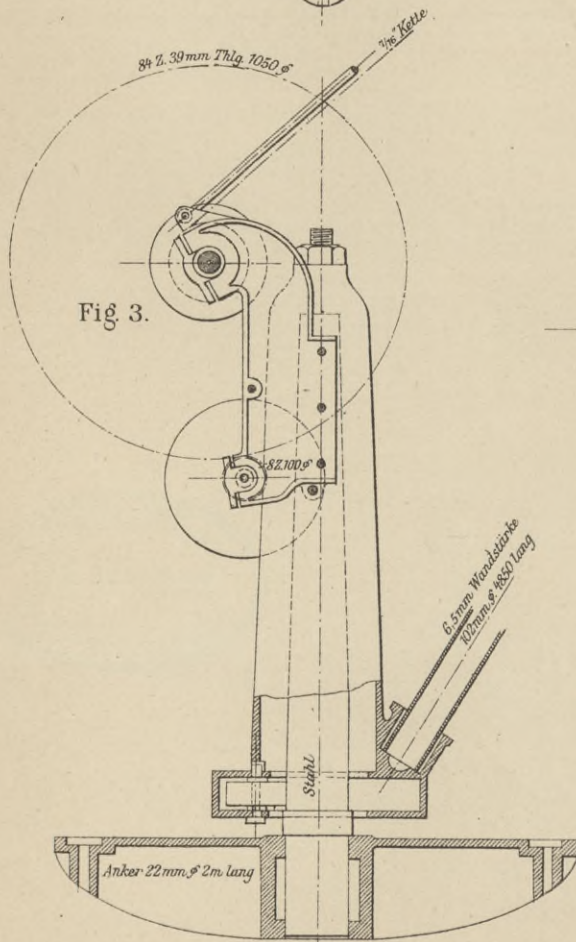
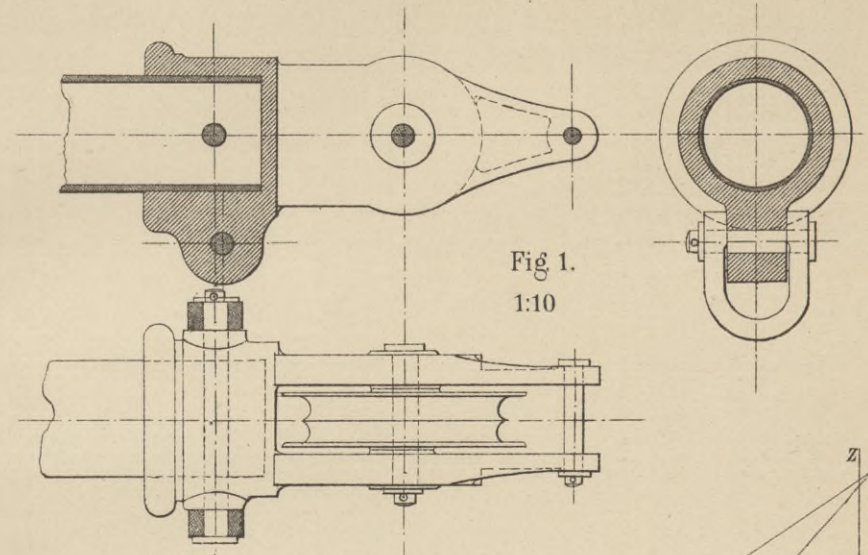

Fig. 3.

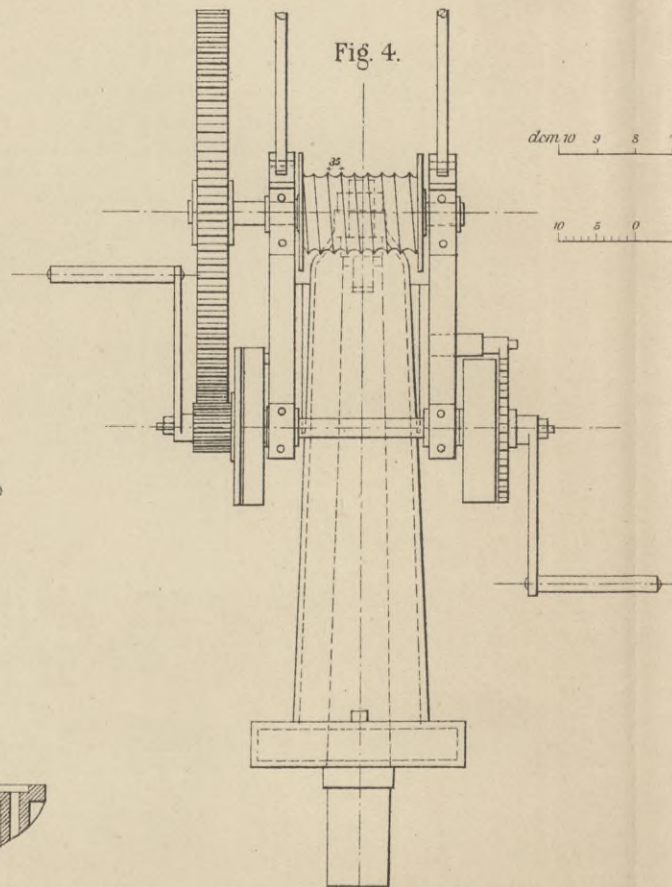

Fig. 4.

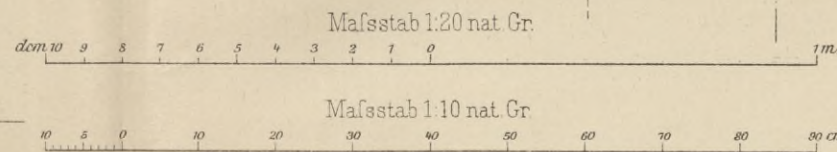
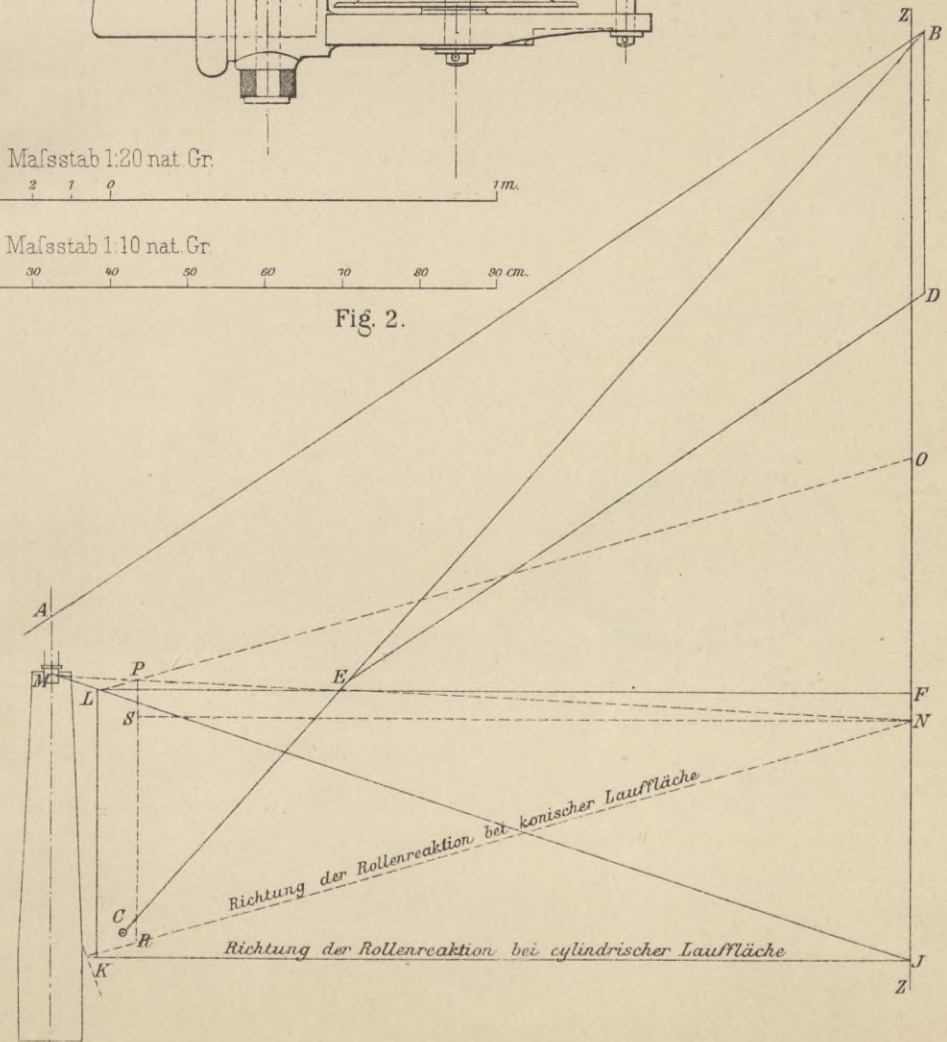

Fig. 2.









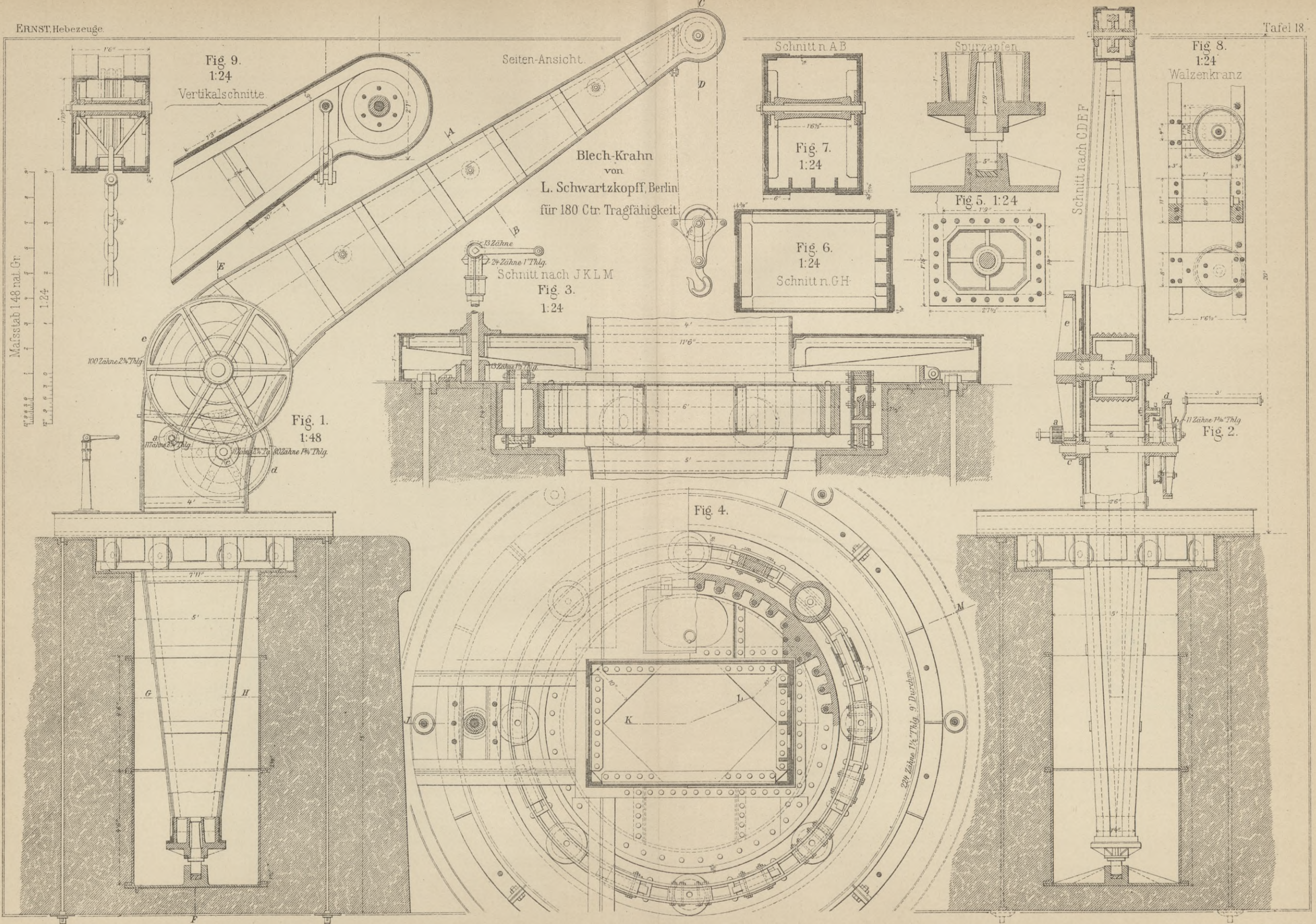

Mafsstab 1:48 nat. Gr.





Fahrbarer Bahnhofskrahn  
von  
Schwanke  
für 60 Ctr. Last.

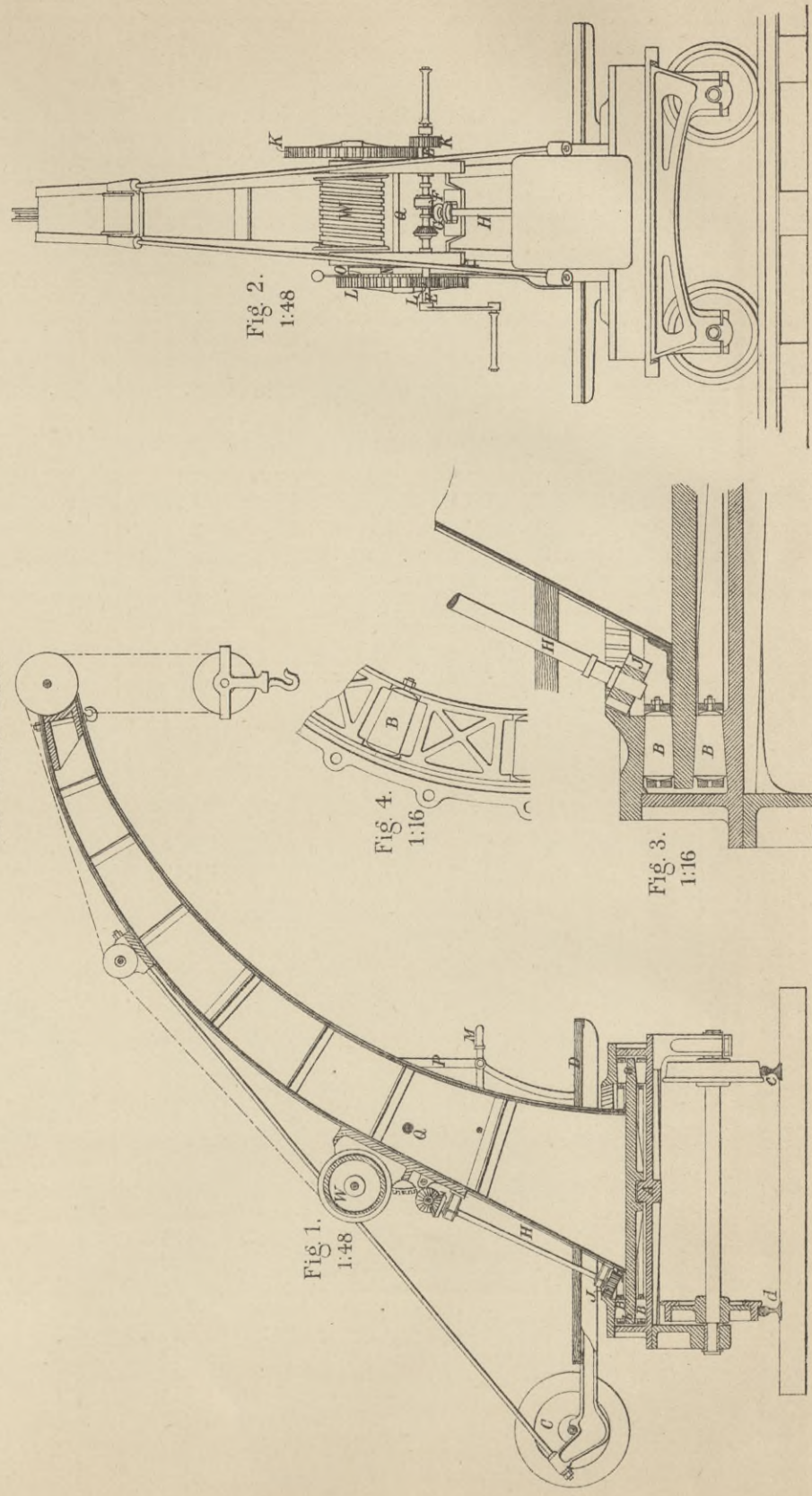

Fig. 1.  
1:48

Fig. 2.  
1:48

Fig. 3.  
1:16

Fig. 4.  
1:16

Maßstab 1:16 nat. Gr.

3 Fuss engl.

Maßstab 1:48 nat. Gr.

10 Fuss engl.

Eisenbahn Waggonkrah  
von  
Elias.

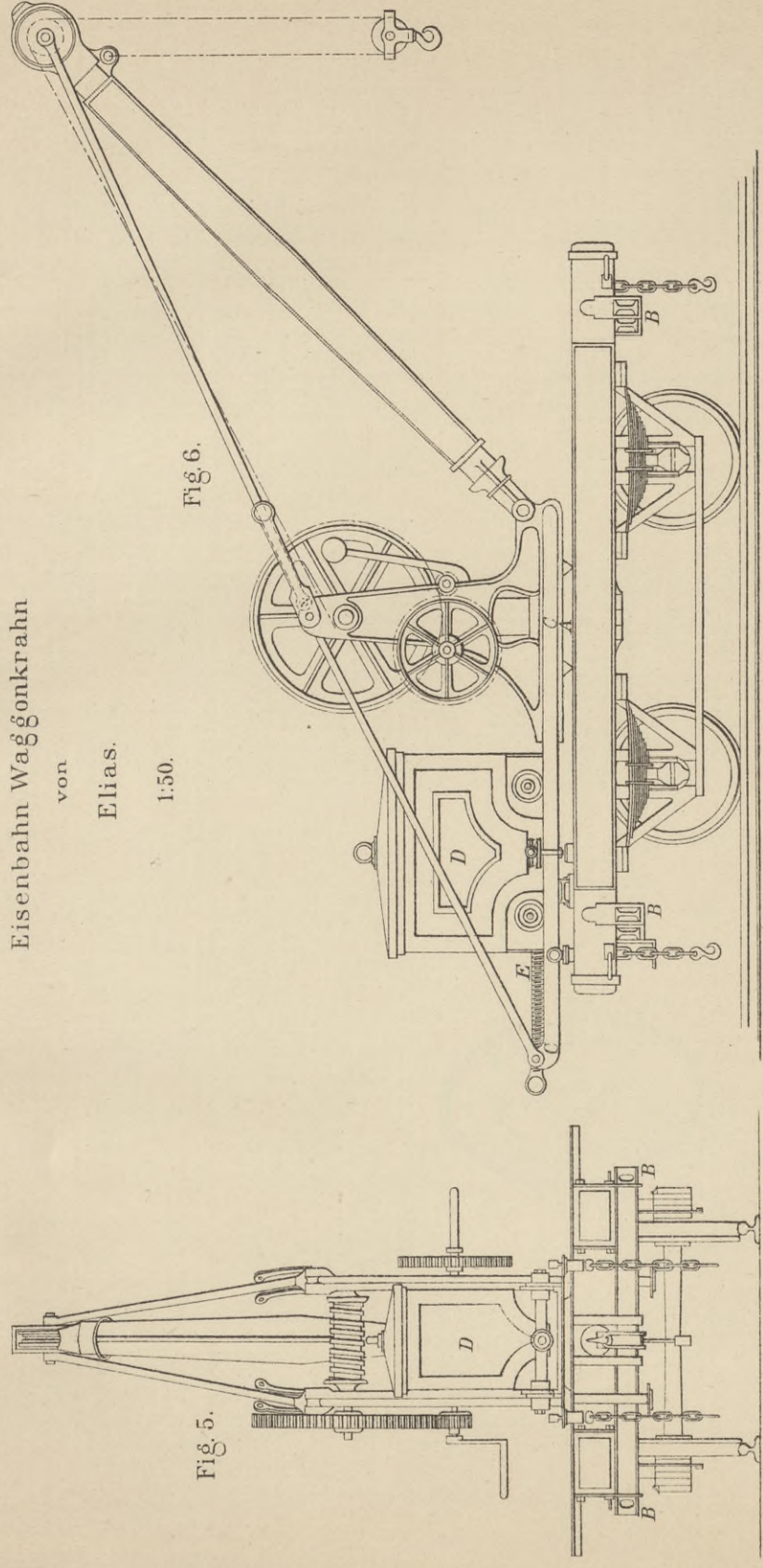

Fig. 5.

Fig. 6.

1:50.

Maßstab 1:50 nat. Gr.

3 m.







Fahrbarer Dampfkrahn  
von  
Waltjen.

Ausladung 24 engl.  
Tragkraft 5000 kg.  
Maschine 120 Umdrehungen  
60 Pfd. Dampfdruck.  
1:24.

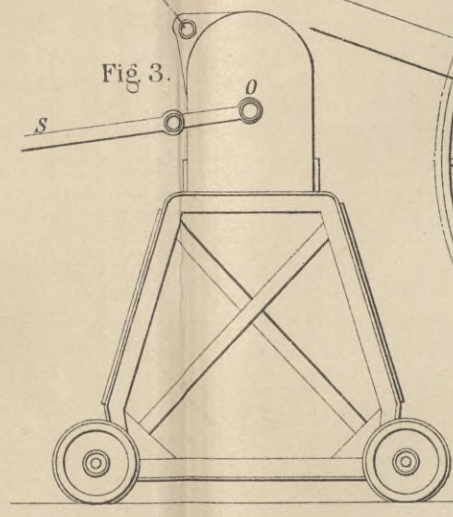
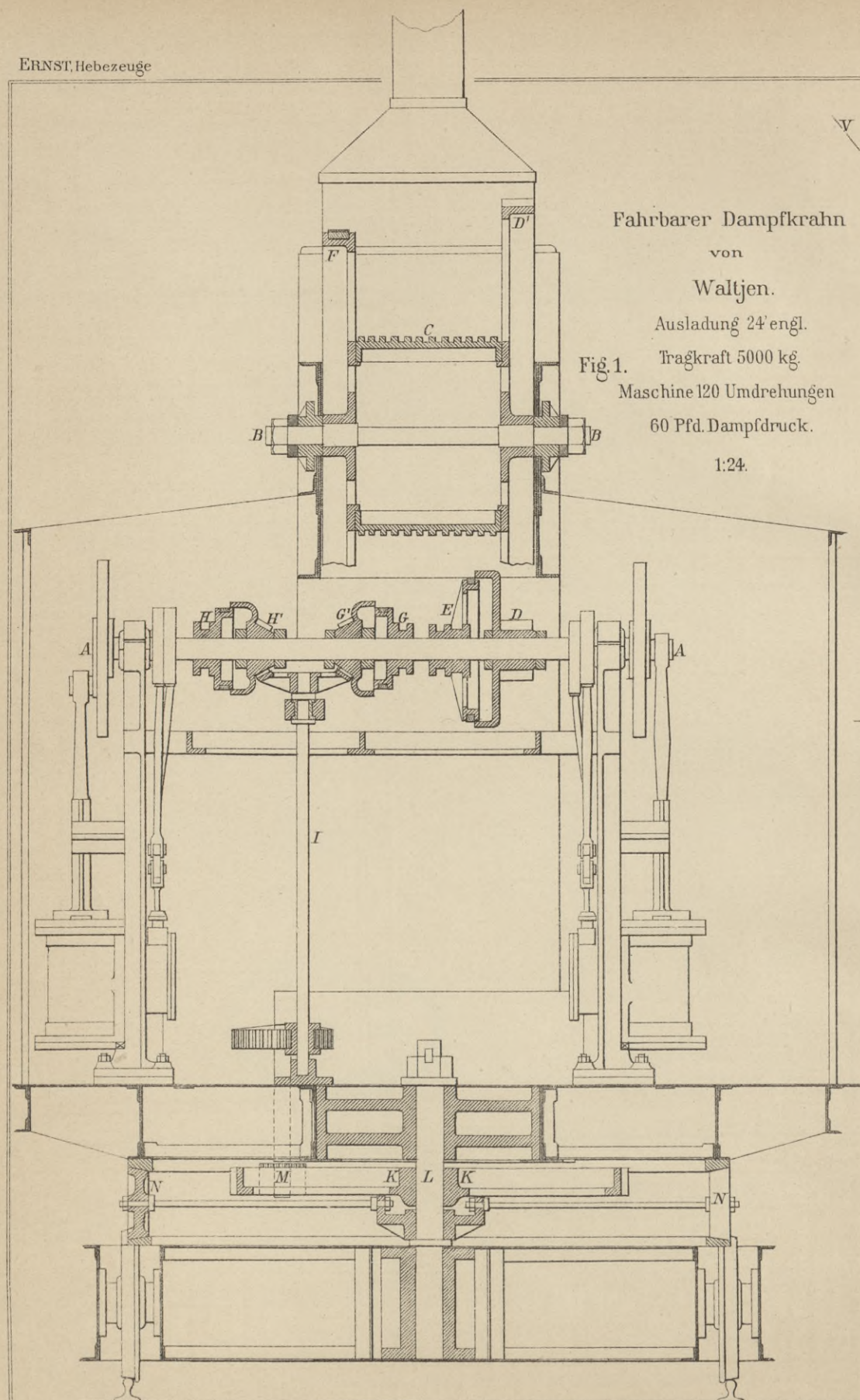
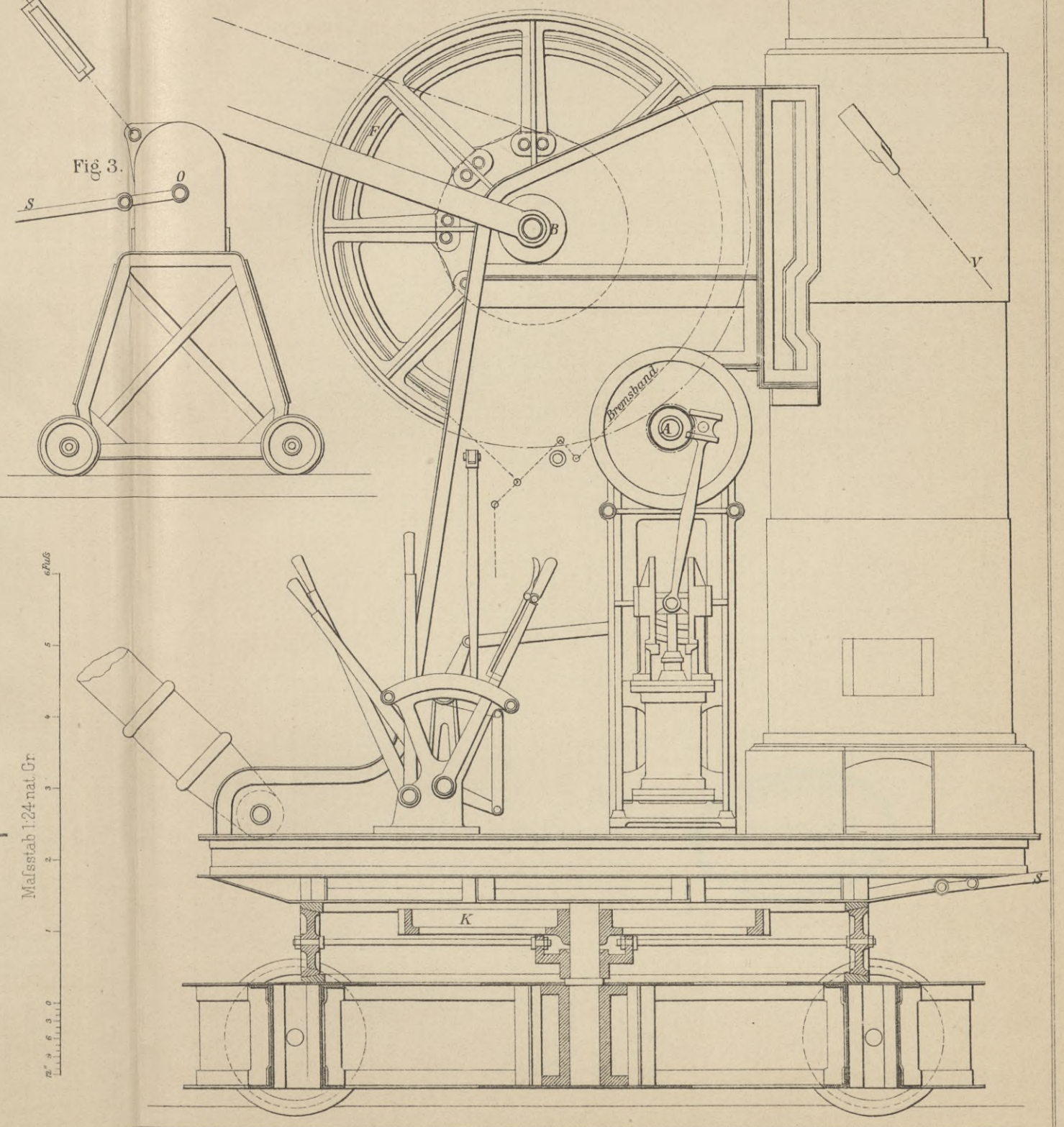

Fig. 2.







Dampfkrahn  
von  
Neustadt  
Fig 1.  
1:40.

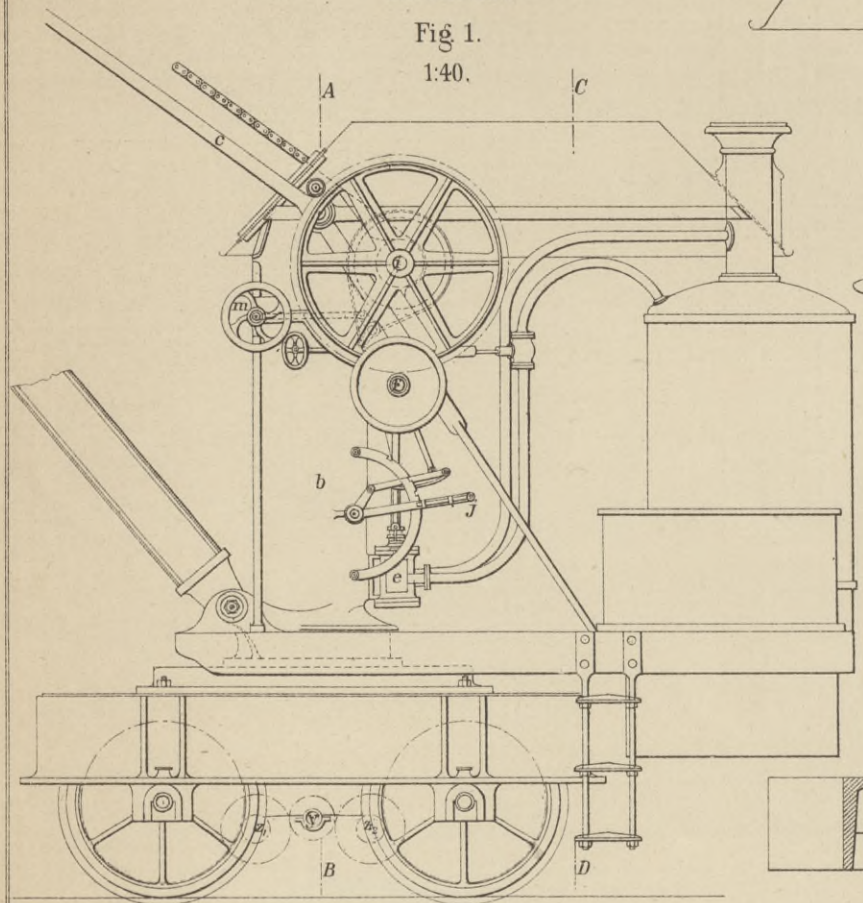

Mafsstab 1:20 nat. Gr.  
10 9 8 7 6 5 4 3 2 1 0 1m.

Mafsstab 1:40 nat. Gr.  
10 9 8 7 6 5 4 3 2 1 0 1 2 3m.

Fig 2.  
1:20.

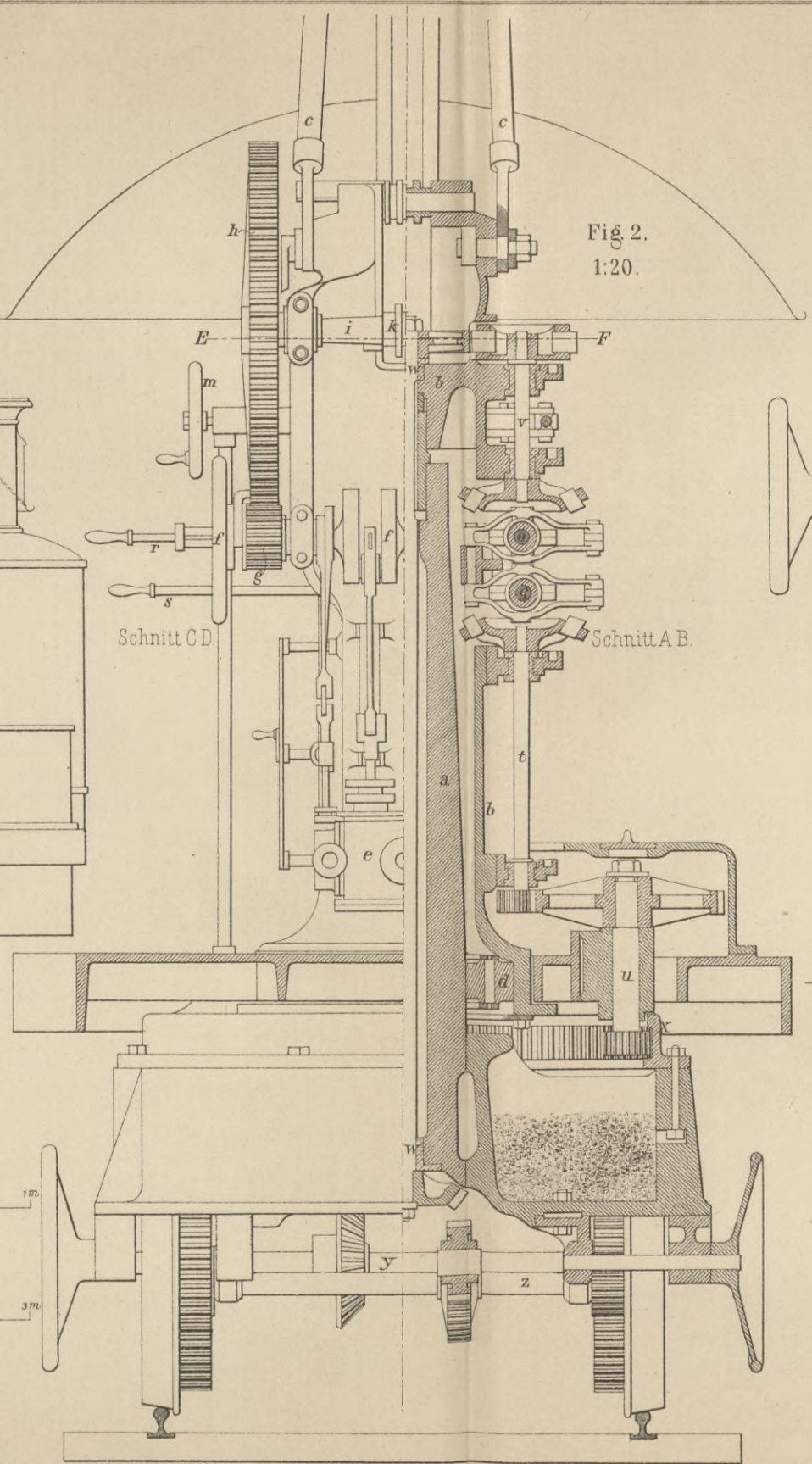
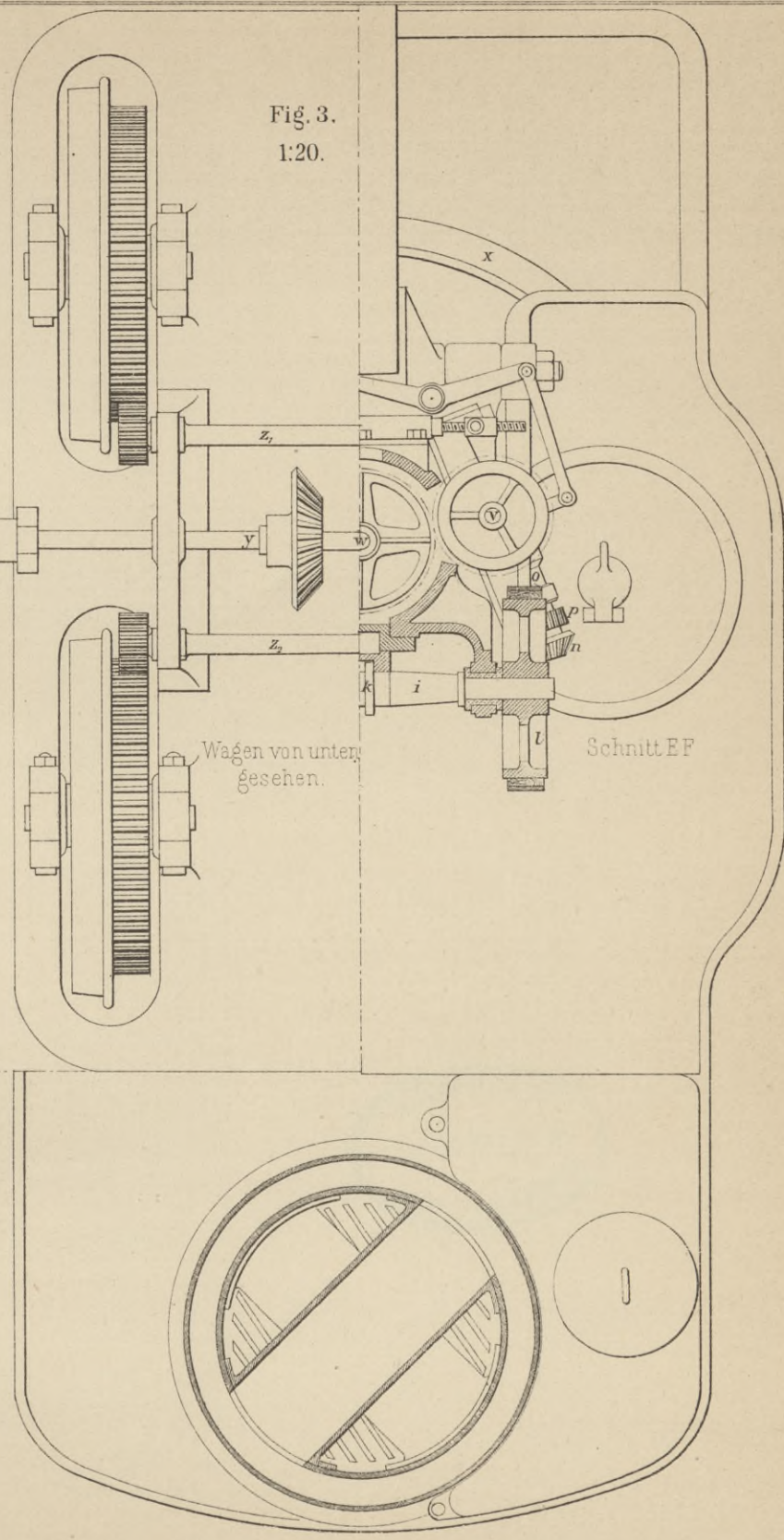

Fig 3.  
1:20.



Wagen von unten  
gesehen.





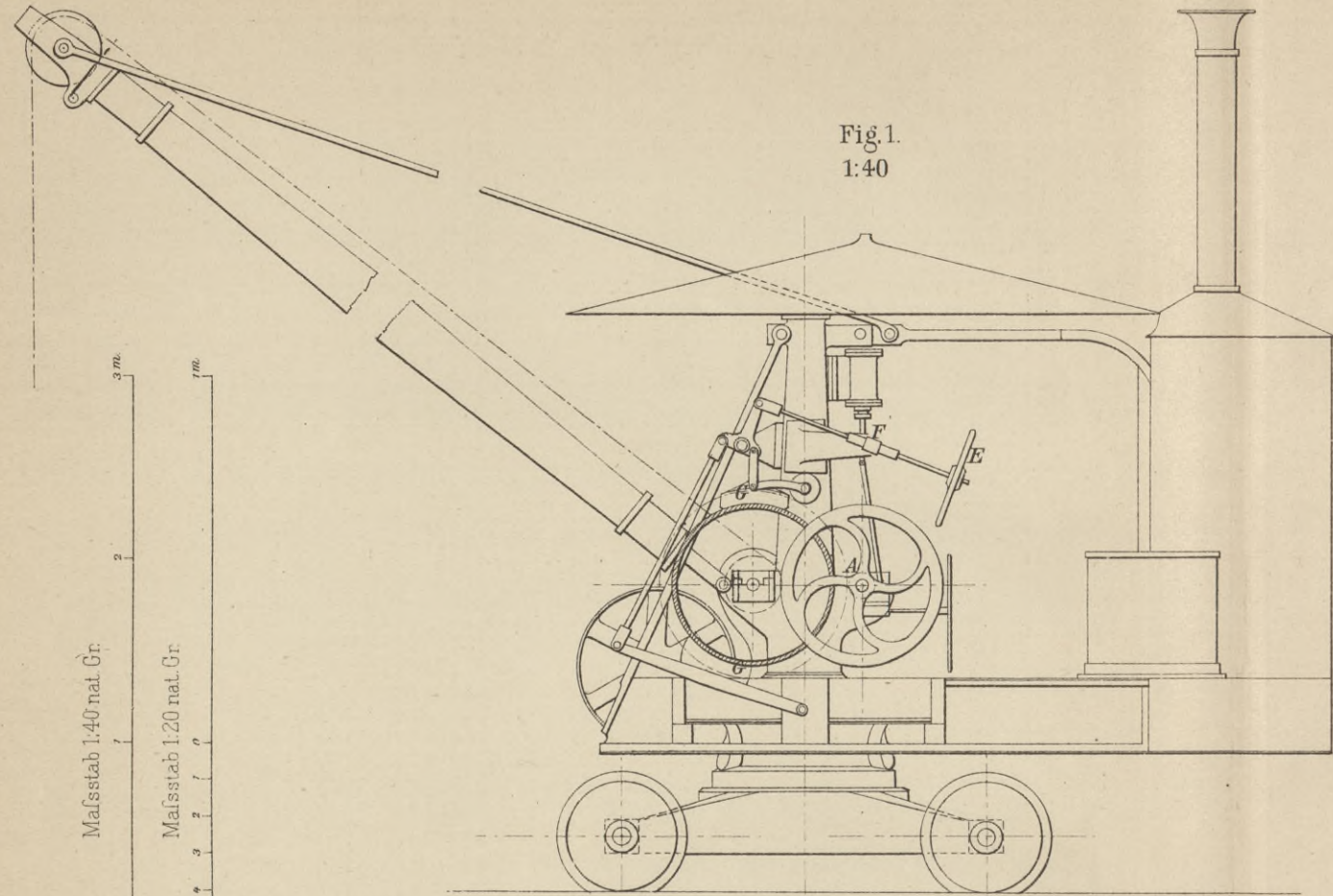

Fig. 1.  
1:40

Dampfkrahn  
von  
Gebr. Schultz.  
in Mainz.

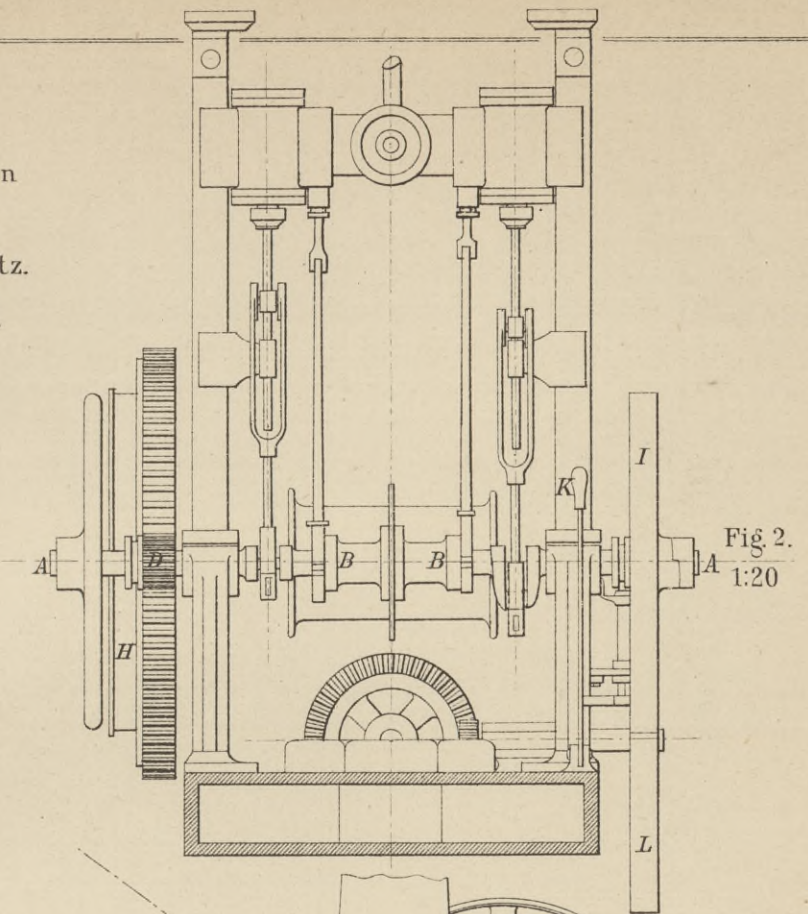
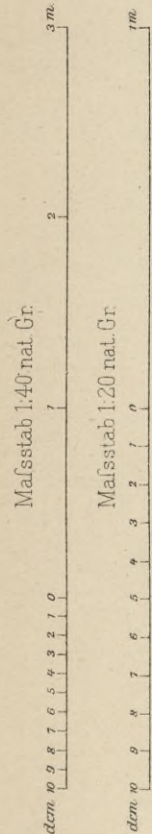

Fig. 2.  
1:20

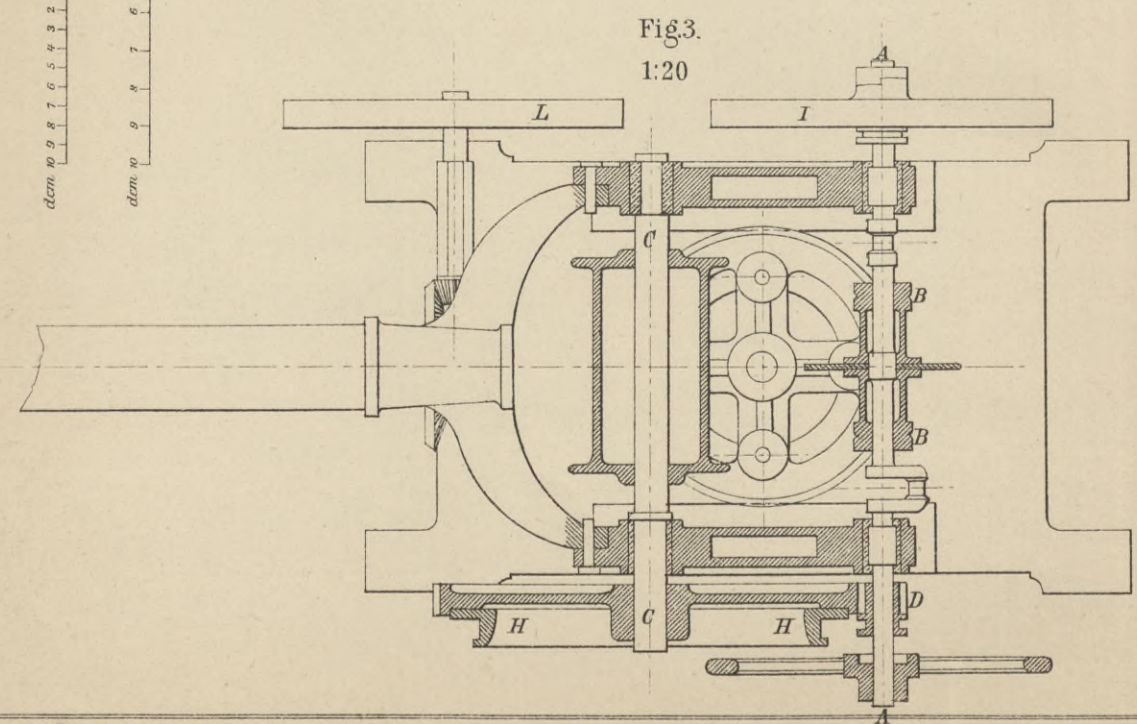

Fig. 3.  
1:20

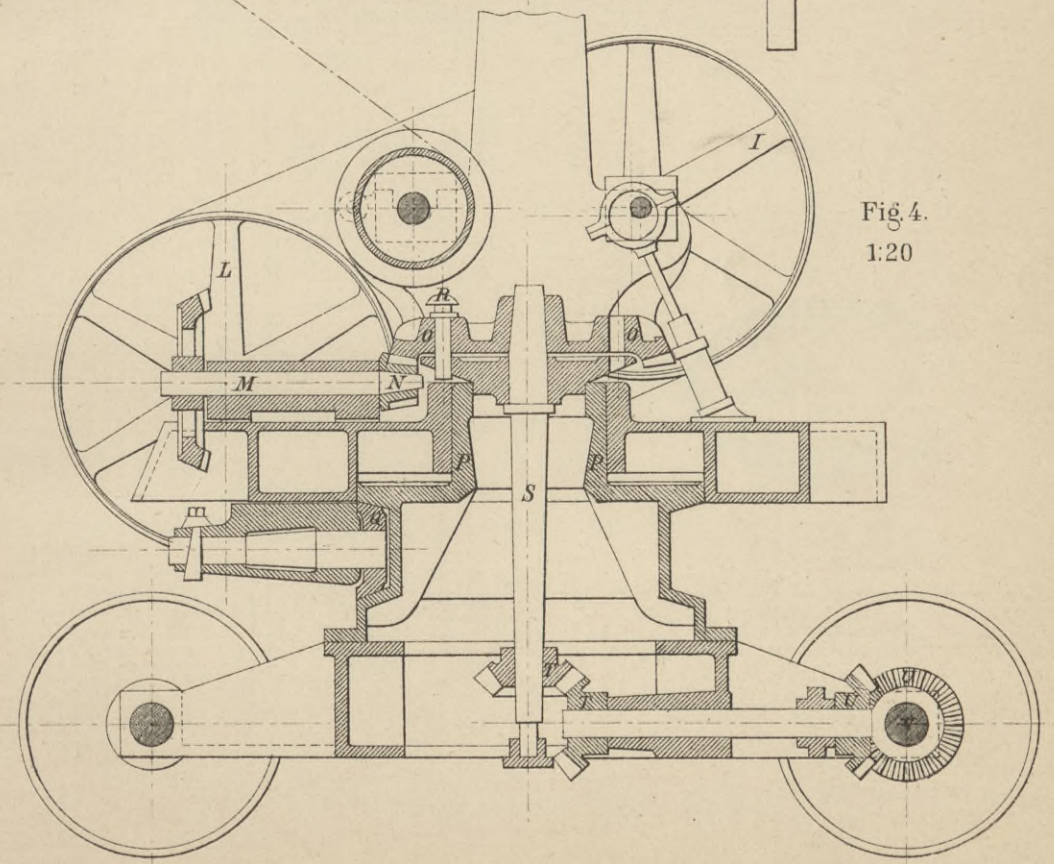

Fig. 4.  
1:20







Krahn  
von  
Wöhlert in Berlin.

Hauptansicht des Krahnes  
Fig. 1.  
1:72

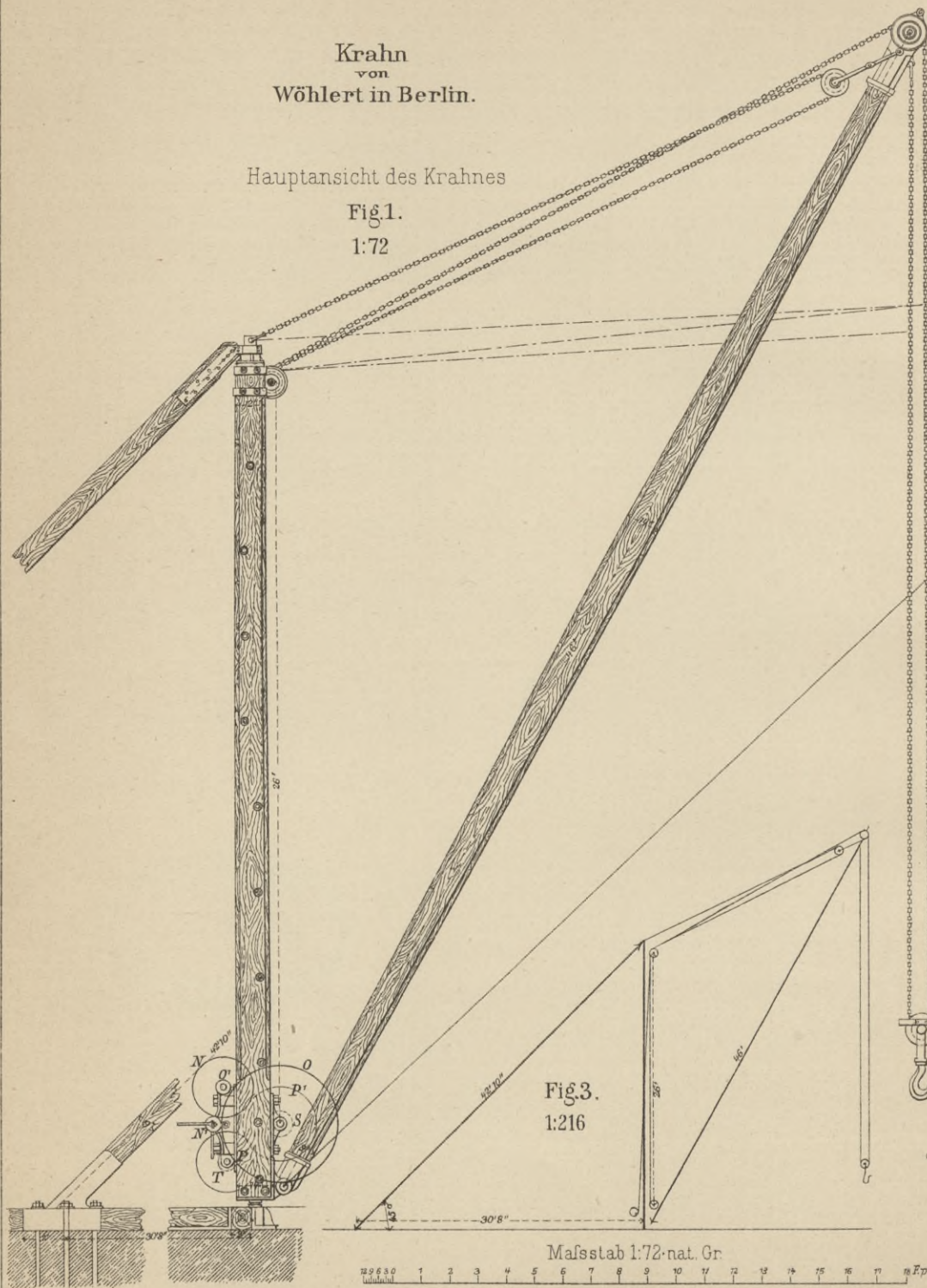

Ansicht der Krahsäule  
Fig. 2.  
1:72

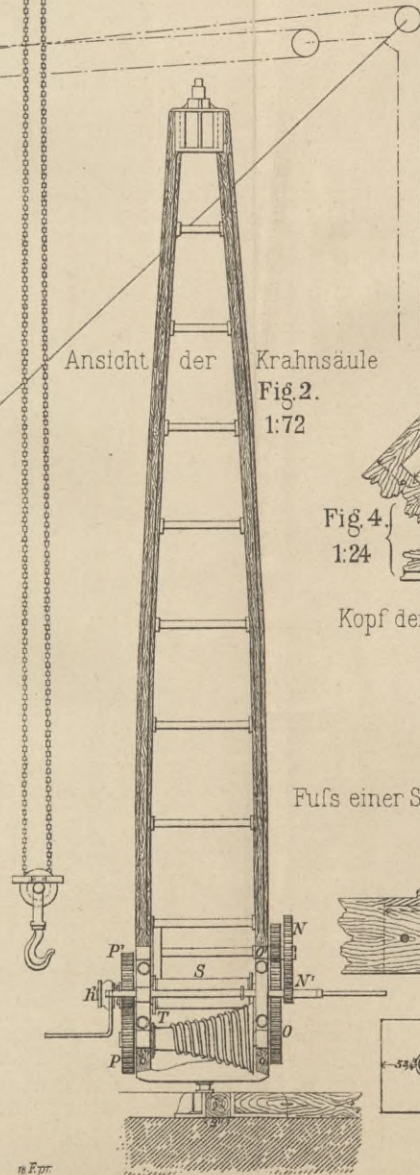

Kopf der beiden Seitenstreben  
Fig. 4.  
1:24

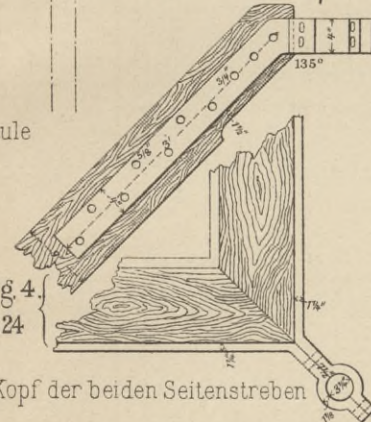

Fufs einer Seitenstrebe  
Fig. 5. 1:24

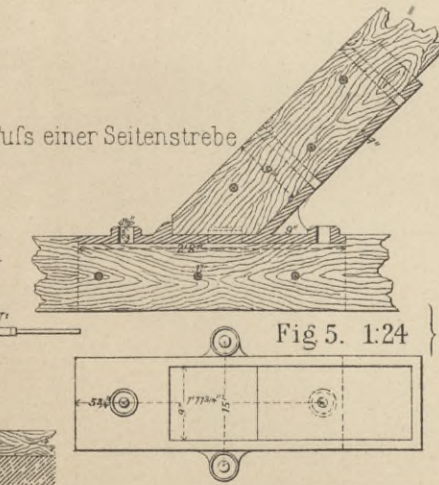

Details zum Mastenkrahn  
für die  
Elbebrücke bei Magdeburg

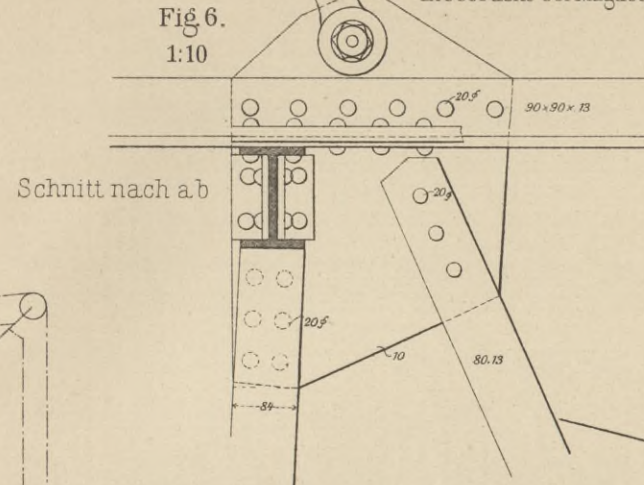
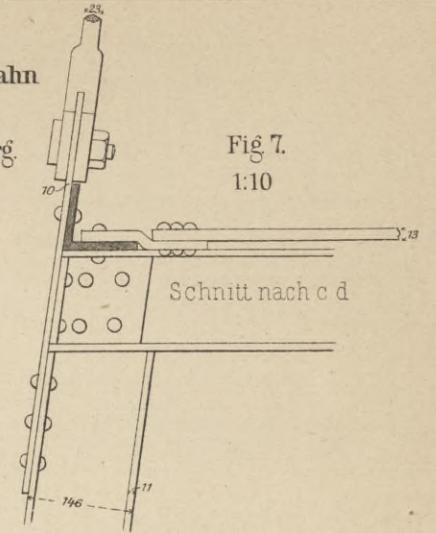

Fig. 7.  
1:10



Grundriss der Leitrollenbühne.  
Fig. 8.  
1:10

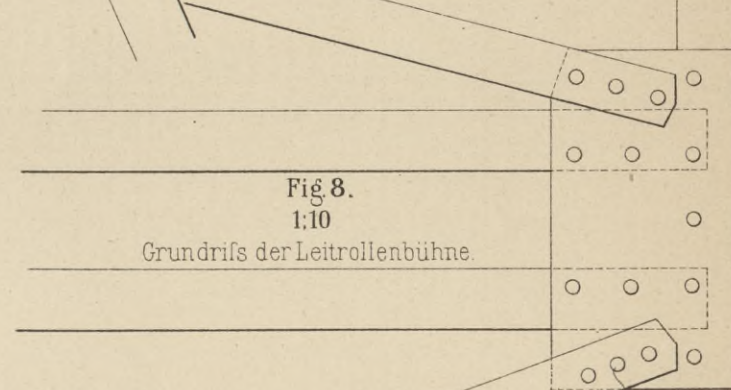
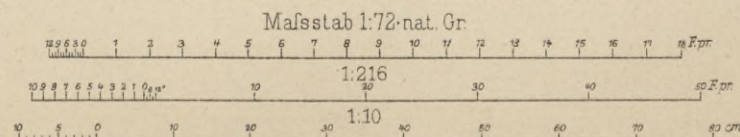
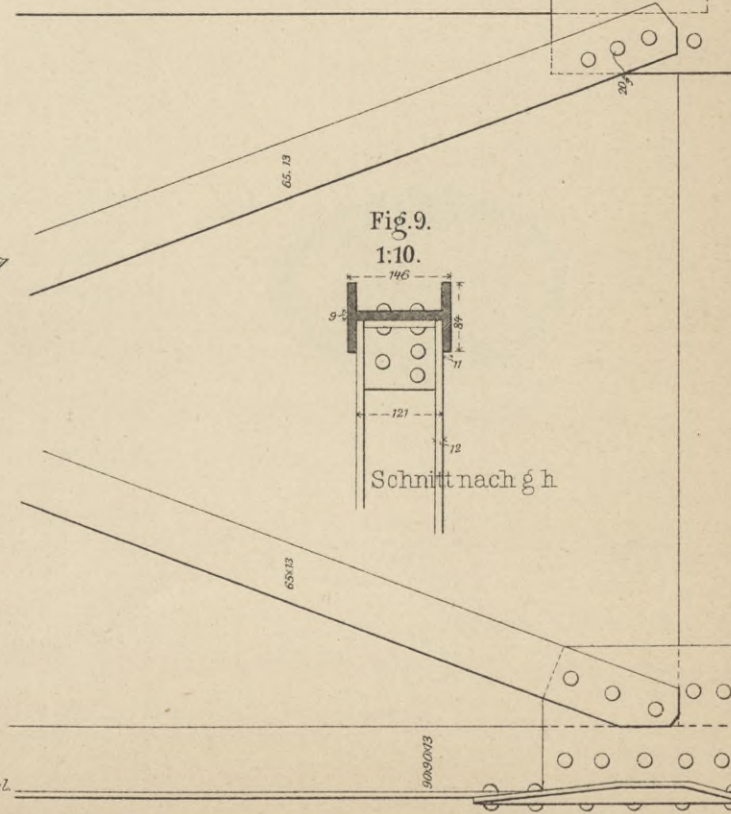

Fig. 9.  
1:10.







Mastenkrahn  
für die  
Elbebrücke bei Magdeburg  
1:72

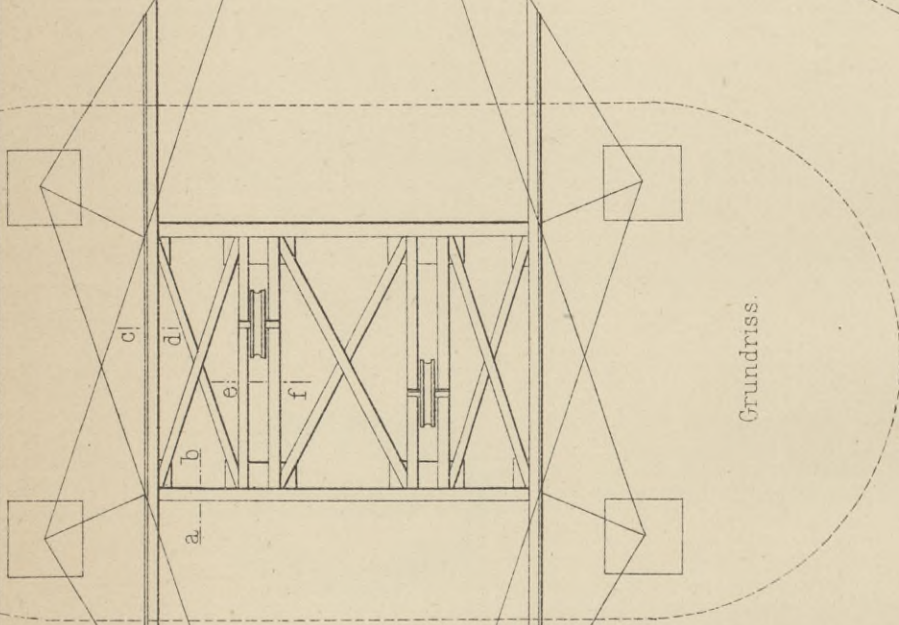

Fig. 3.

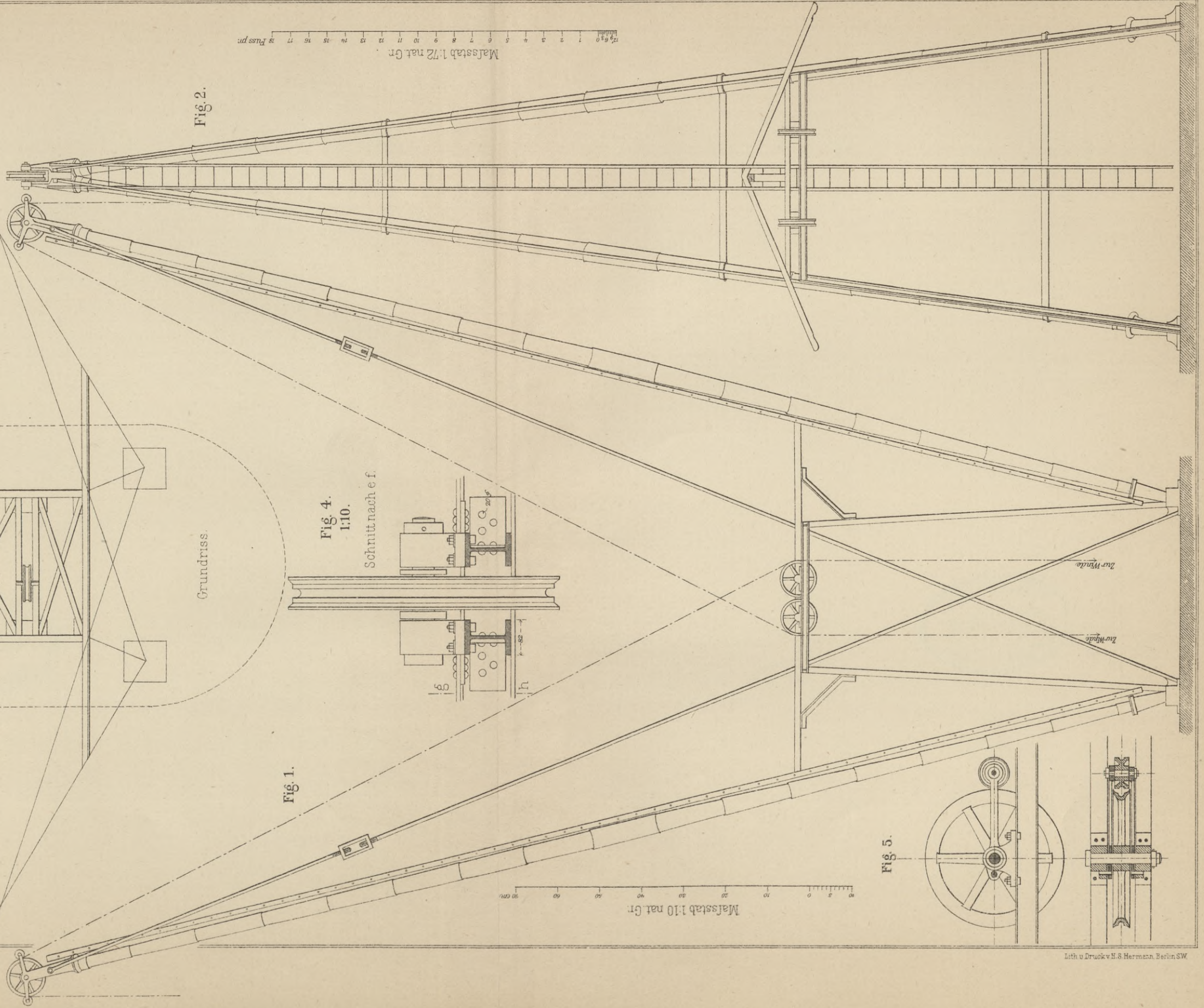

Fig. 1.

Grundriss.

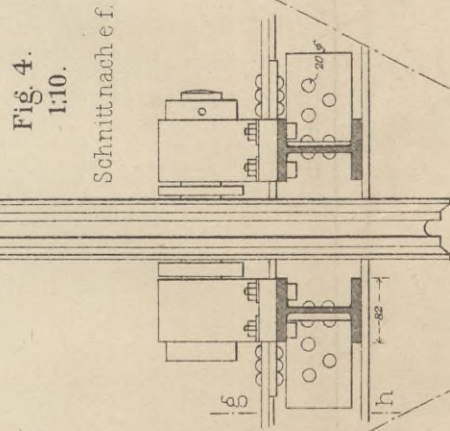

Fig. 4.  
1:10.

Schnitt nach e f.

Maststab 1:72 nat Gr  
18 17 16 15 14 13 12 11 10 9 8 7 6 5 4 3 2 1 0 1 2 3 4 5 6 7 8 9 10 11 12 13 14 15 16 17 18 Fuss par.

Fig. 2.

Fig. 5.

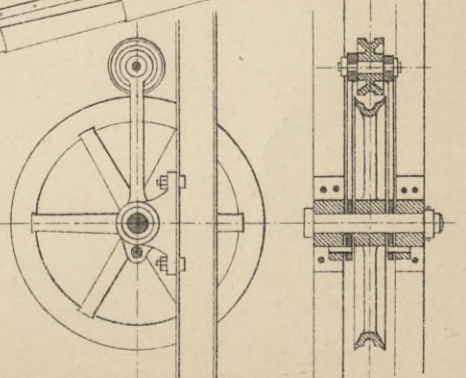



























# Laufkrahne zu 400 Ctr. Tragkraft mit Details.

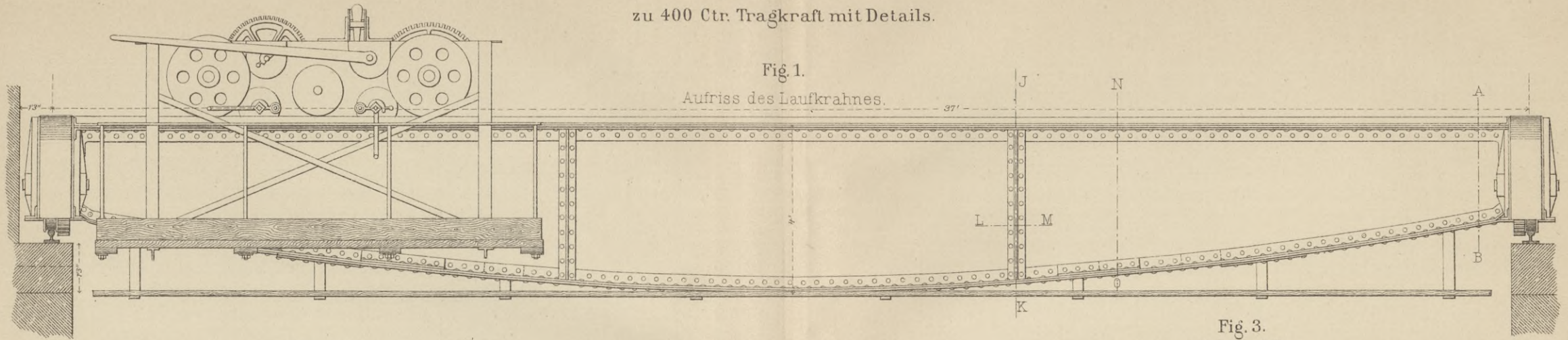

Fig. 1.

Aufriss des Laufkrahnes.

Fig. 3.  
Schnitt A-B.

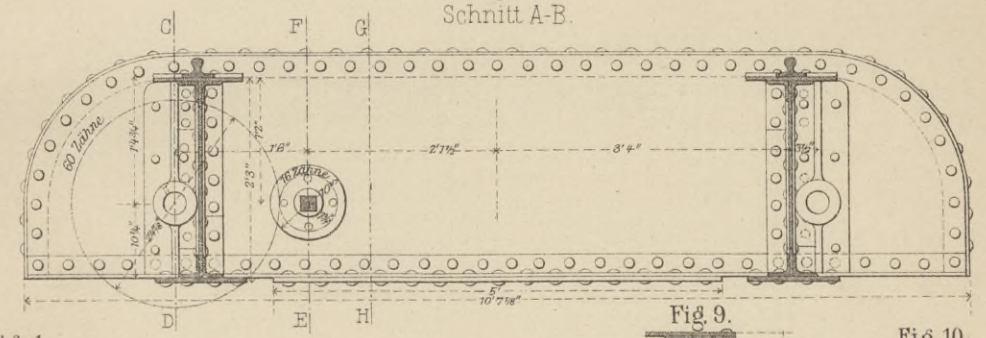

Fig. 2.  
Halber Grundriss.

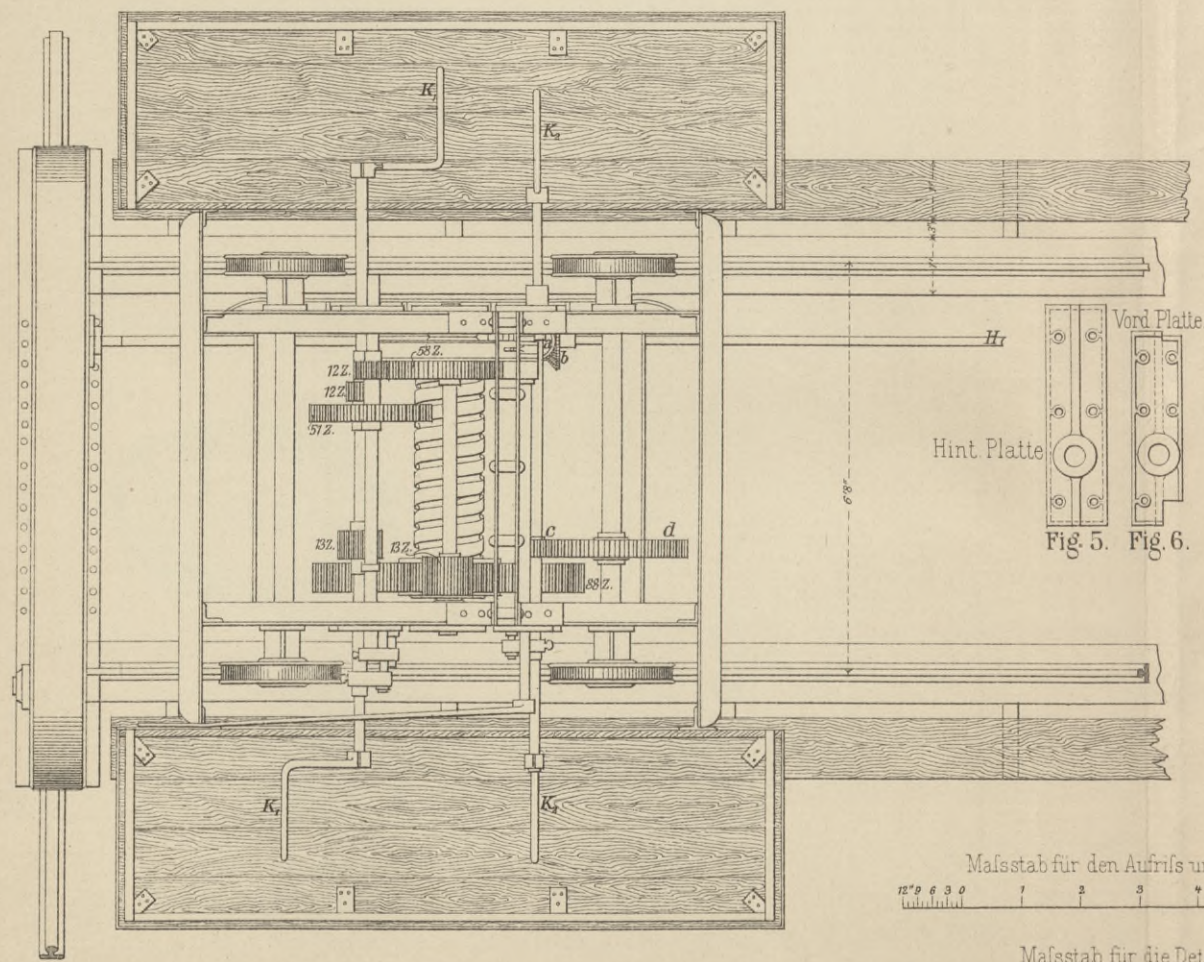

Fig. 4.  
Schnitt C-D.

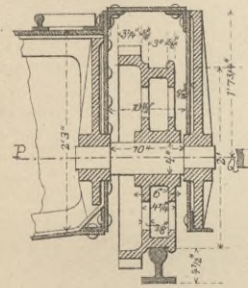

Fig. 7.  
Schnitt E-F.

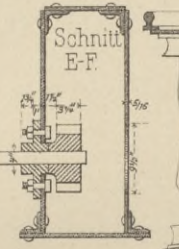
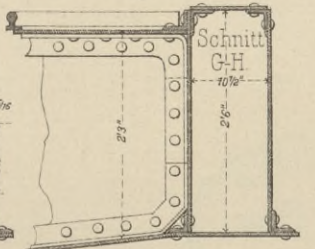

Fig. 8.  
Schnitt G-H.



Grundriss der Fig. 8.

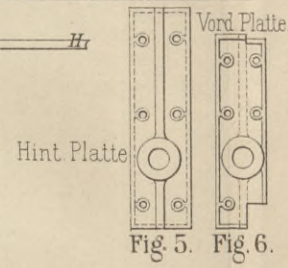
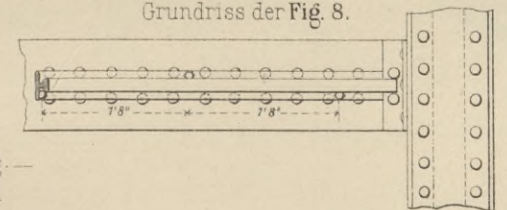

Fig. 6.

Hint. Platte

Fig. 11.  
Schnitt P-Q.

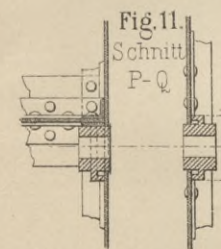

Fig. 9.

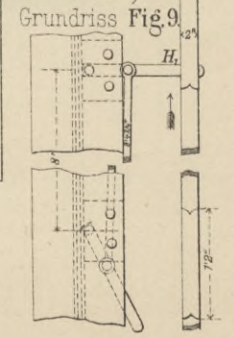
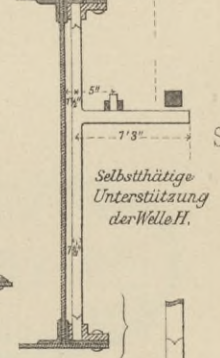

Fig. 10.

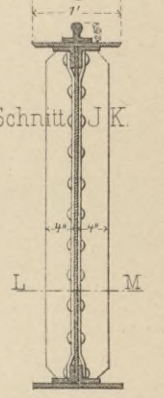

Fig. 13.  
Schnitt L-M.

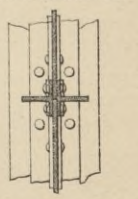
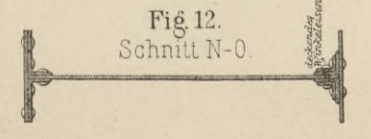
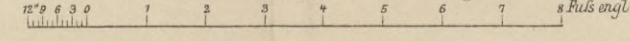

Fig. 12.  
Schnitt N-O.



Maisstab für den Aufriss und Grundriss Fig. 1 u. 2.



Maisstab für die Details Fig. 3-13.

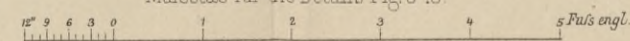



BIBLIOTEKA

KRAKÓW

Techniczna



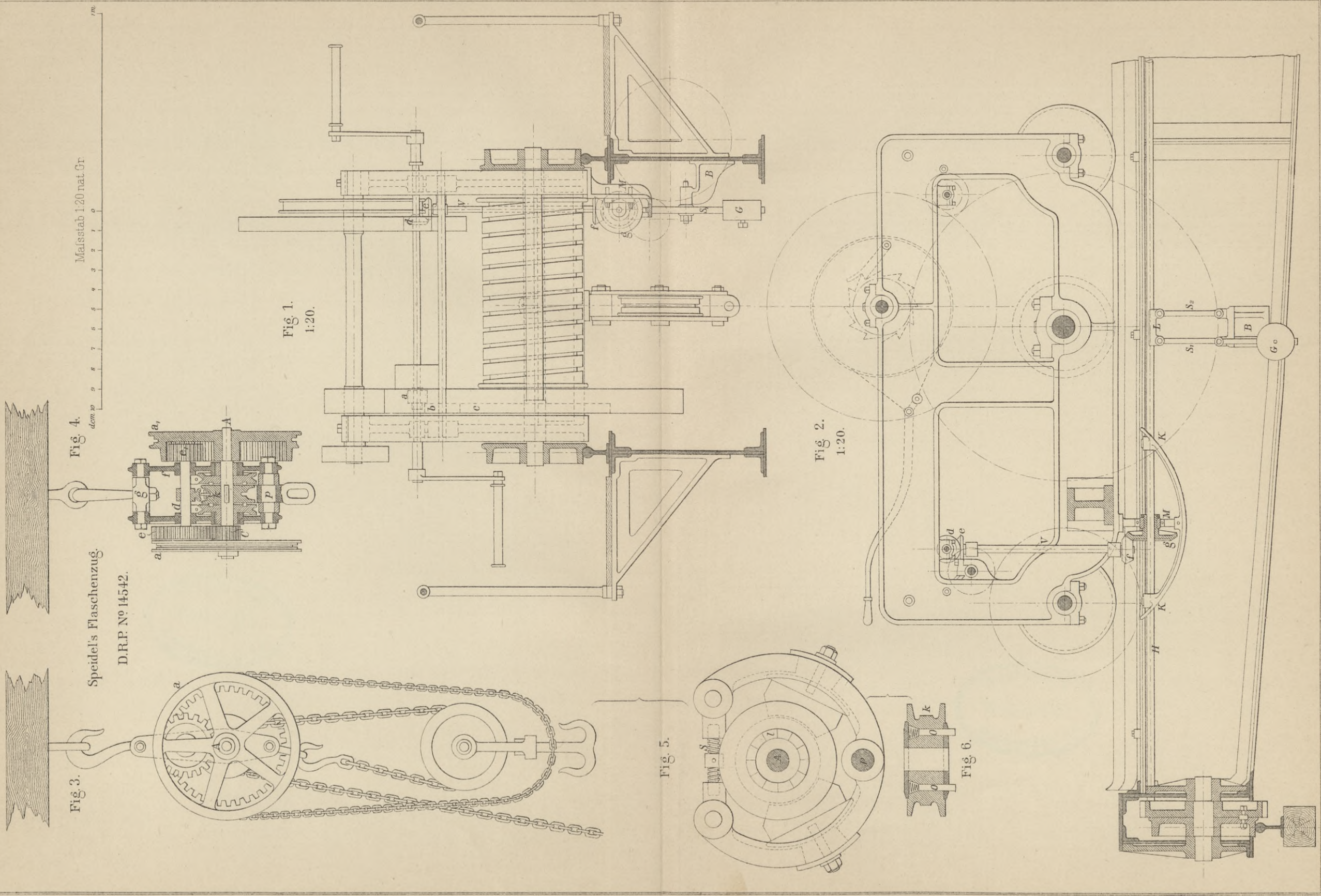













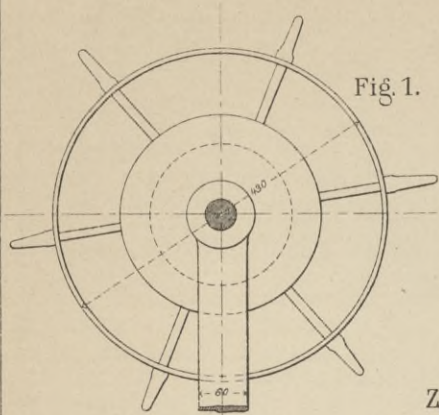

Fig. 1.

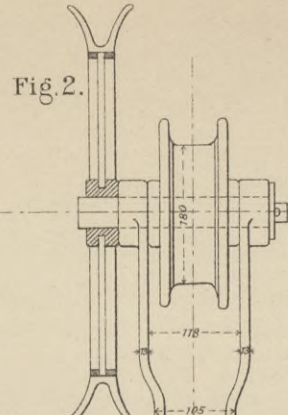

Fig. 2.

Zug-Winde  
für 80 Ctr. Last  
von  
E. Becker  
1:10.

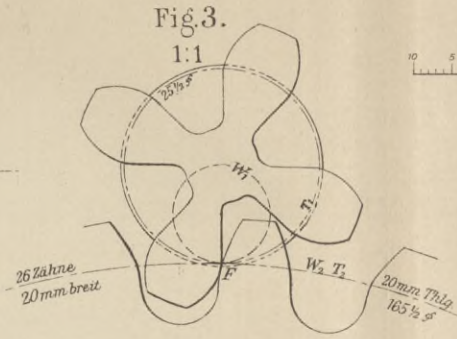
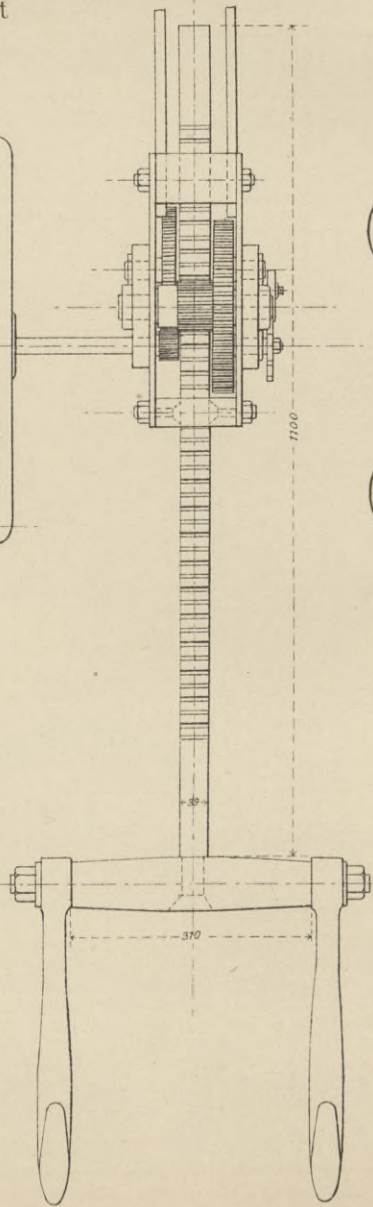
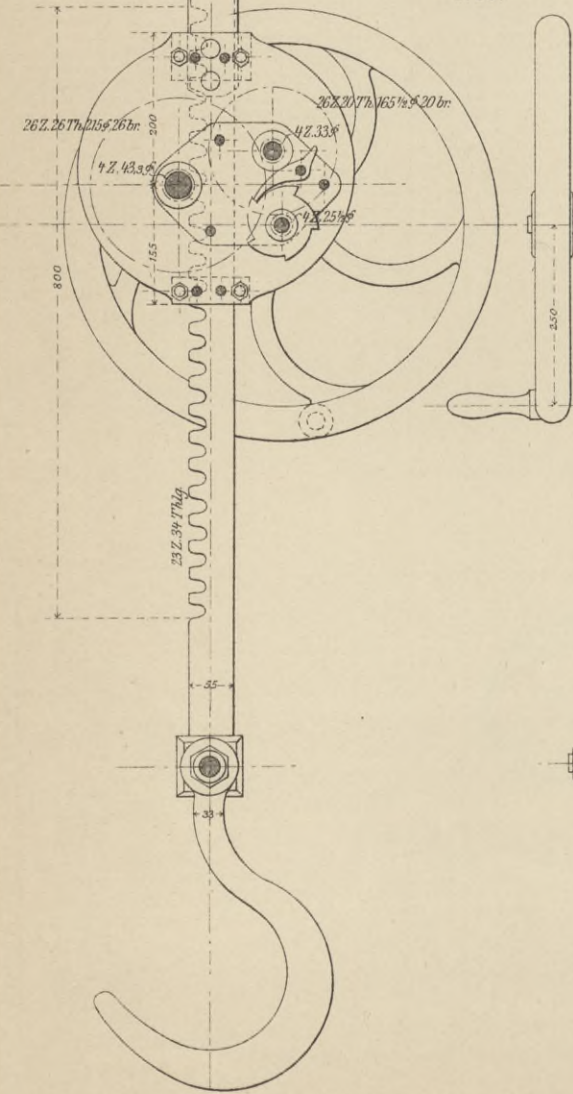

Fig. 3.

1:1

26 Zähne  
20 mm breit  
30 mm Thlg  
165 1/2 s

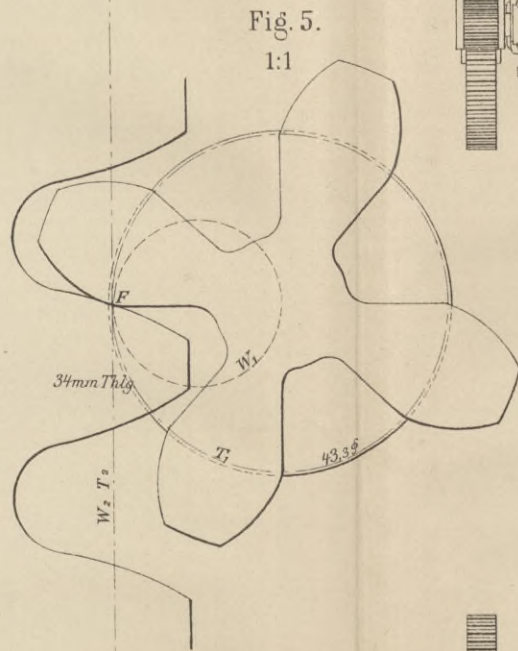

Fig. 5.

1:1

34 mm Thlg  
43,3 s  
W<sub>2</sub> T<sub>2</sub>

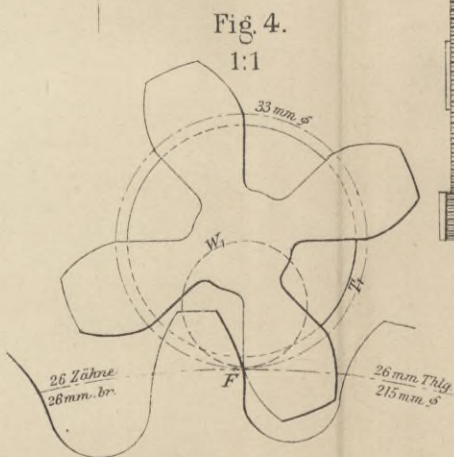

Fig. 4.

1:1

26 Zähne  
26 mm br.  
26 mm Thlg  
215 mm s

Mafsstab 1:10 nat Gr

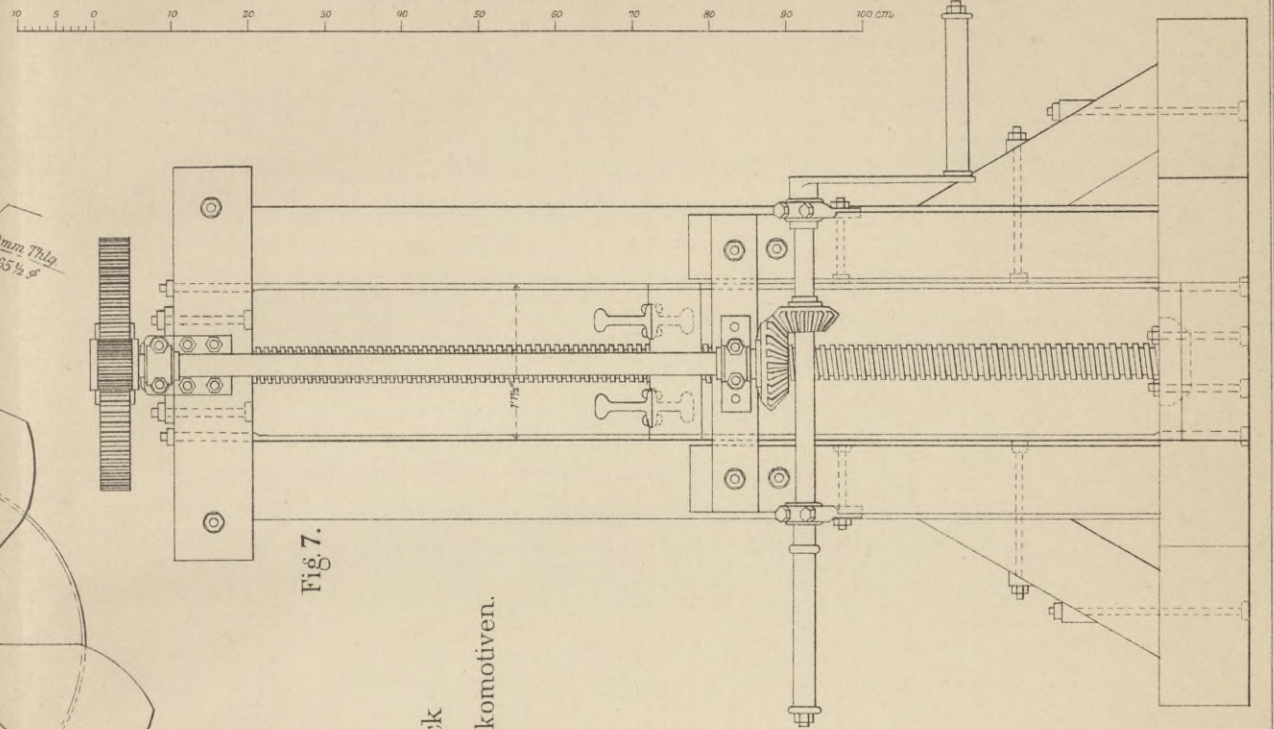

Fig. 7.

Winde-Bock  
zum Heben der Lokomotiven.

1:18.

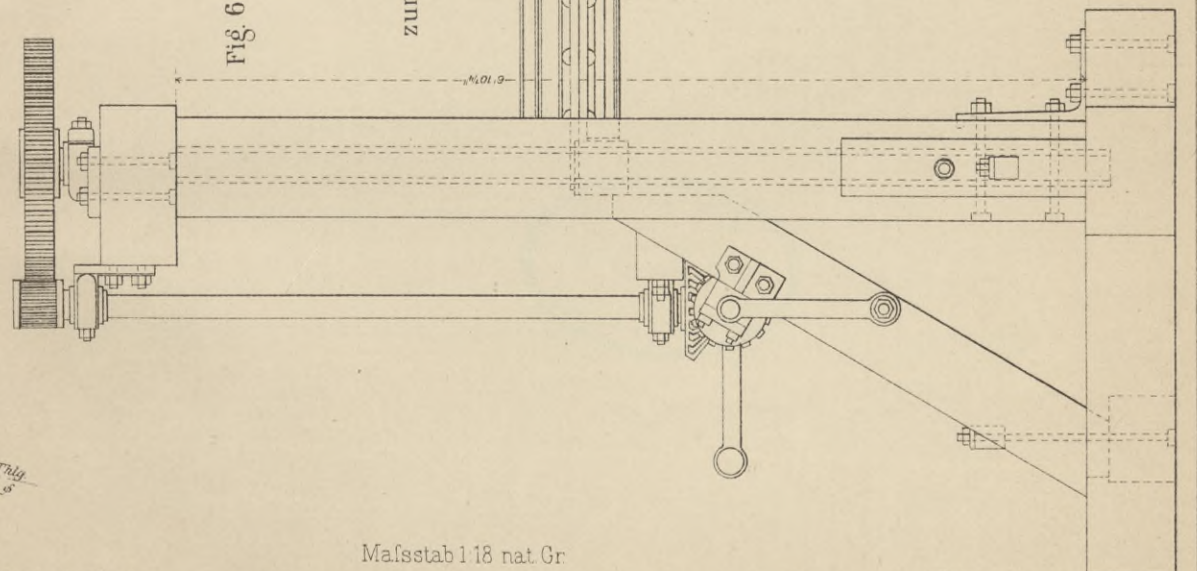

Fig. 6.

Mafsstab 1:18 nat Gr

12 9 6 3 0 1 2 3 4 5 6 Fu./S.





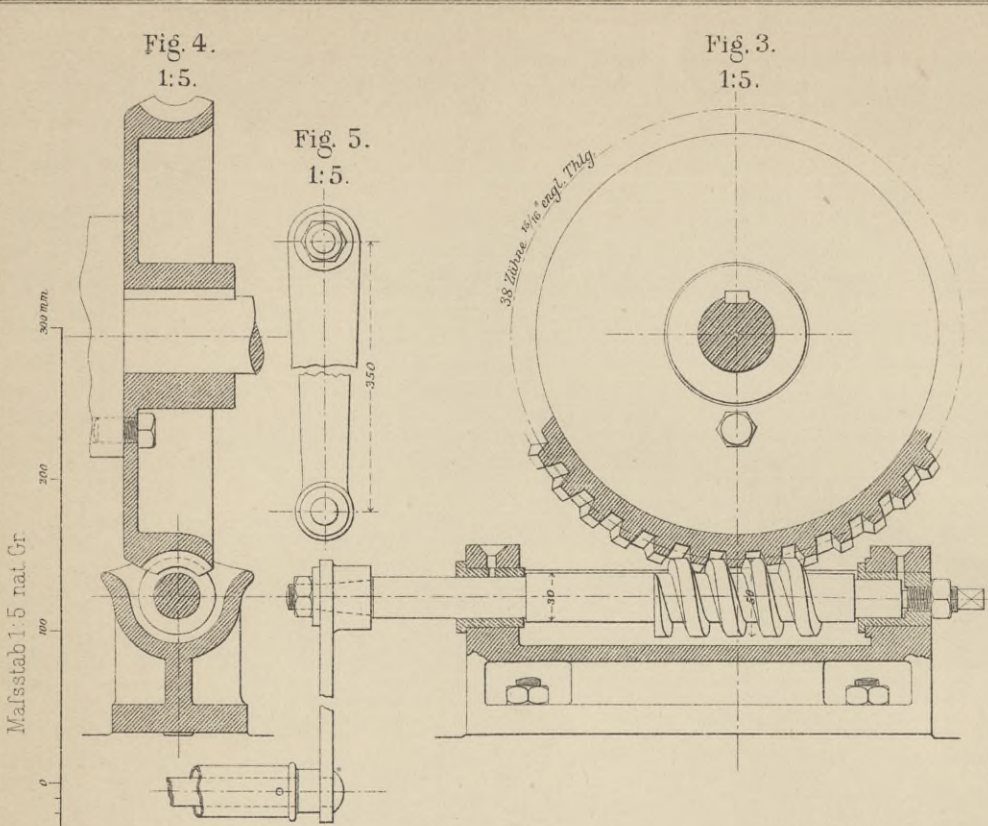

Schraubenflaschenzug mit Patent Drucklager  
von E.Becker in Berlin.  
Zulässige Belastung 2000 kg.

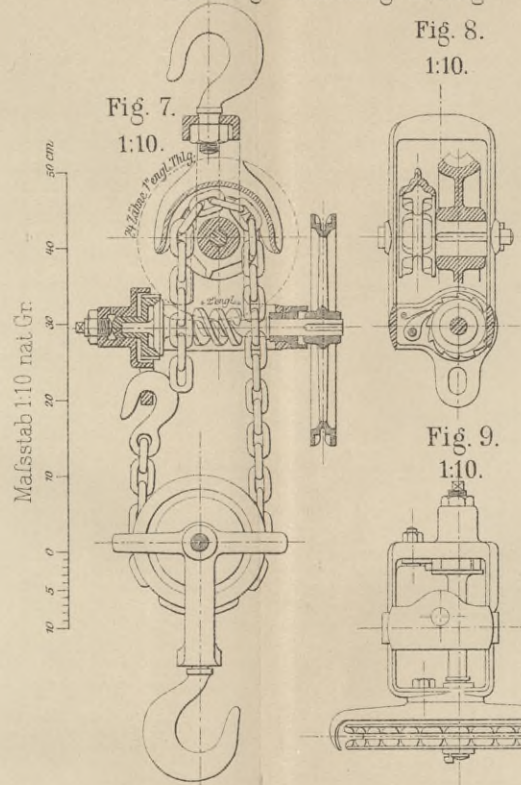

Laufkrahnen mit Seilbetrieb  
von  
Ramsbottom.

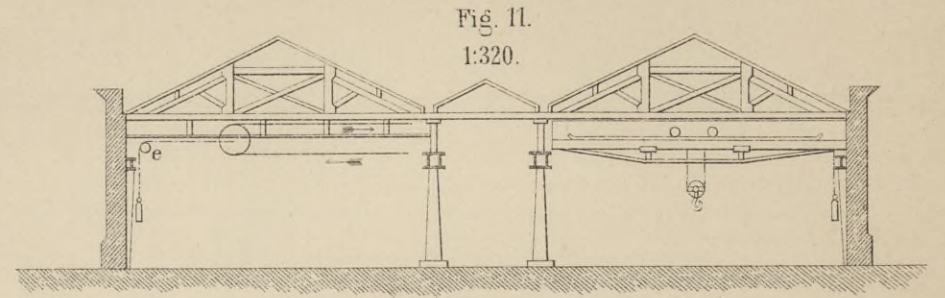

Grundriss u. Querschnitt der Lokomotiv-Reparatur Werkstatt mit Laufkrananlage  
zu Crewe.

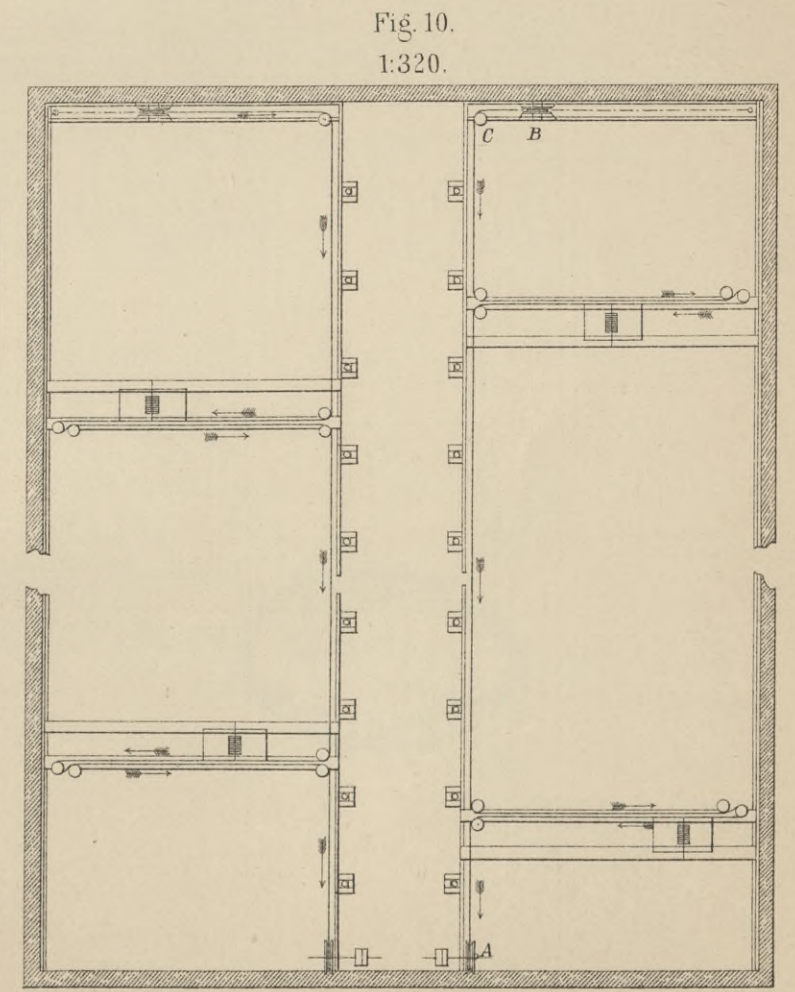

50 Ctr. Winde  
von  
E.Becker.  
1:5.

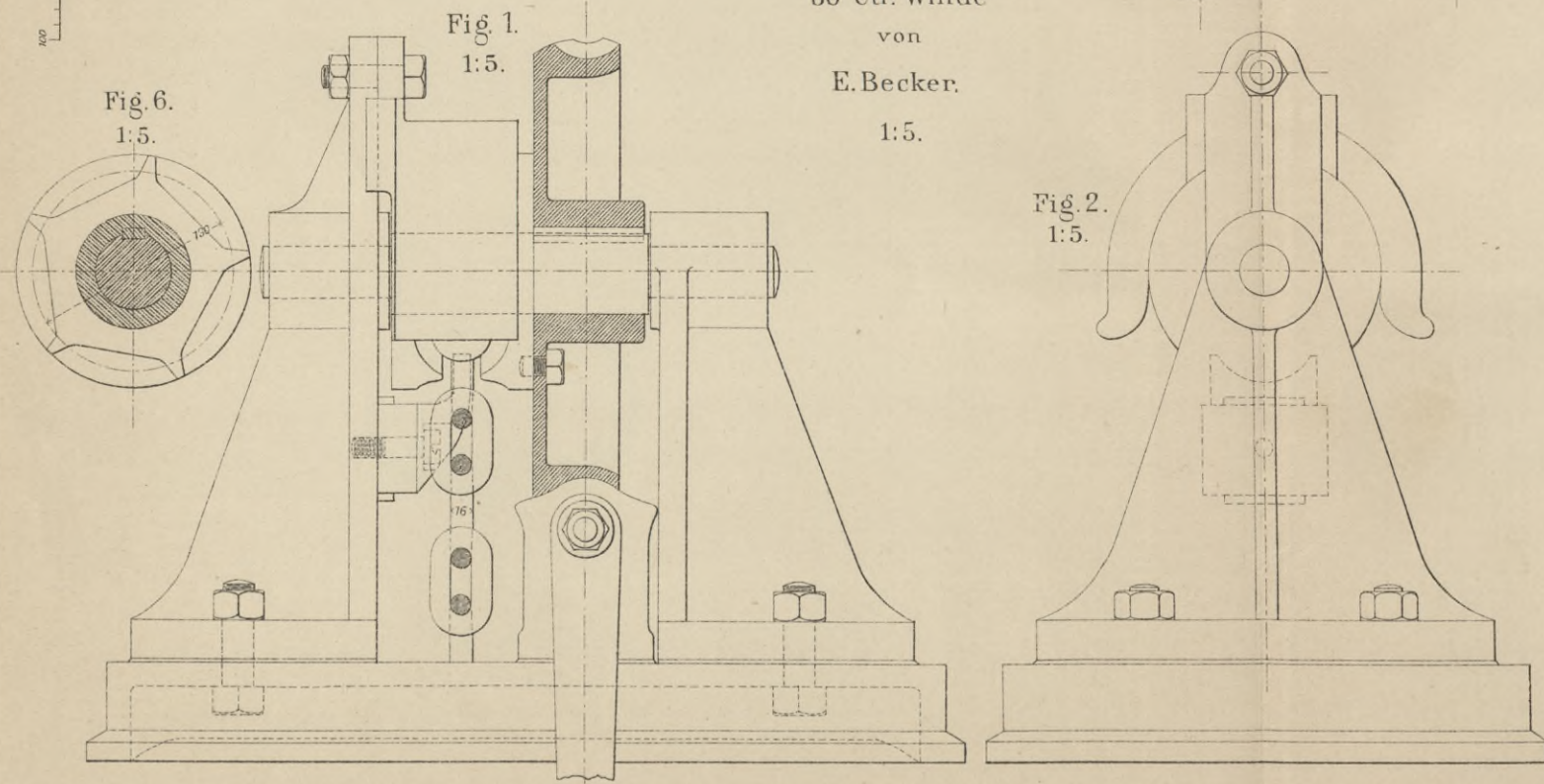
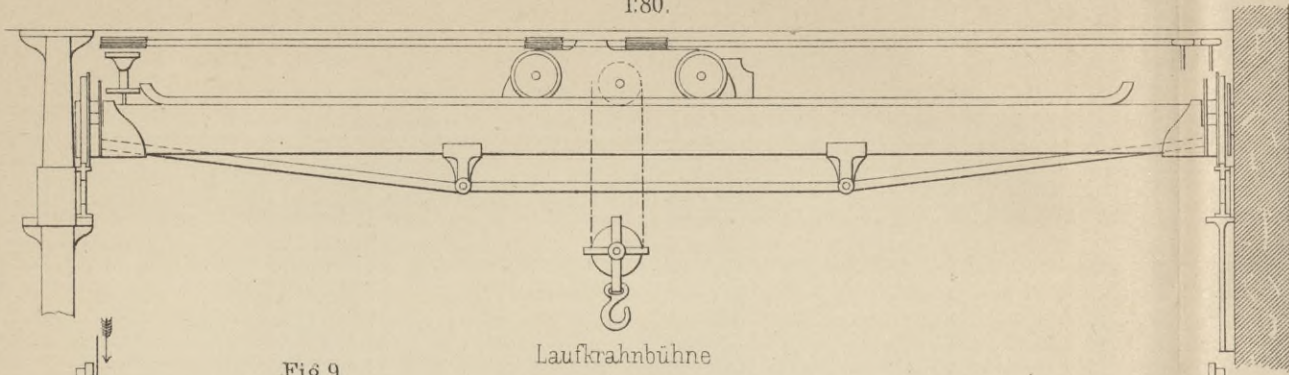





Fig. 8.  
1:80.



Laufkrahne  
mit  
Seilbetrieb  
von  
Ramsbottom.

Fig. 1.  
1:160.

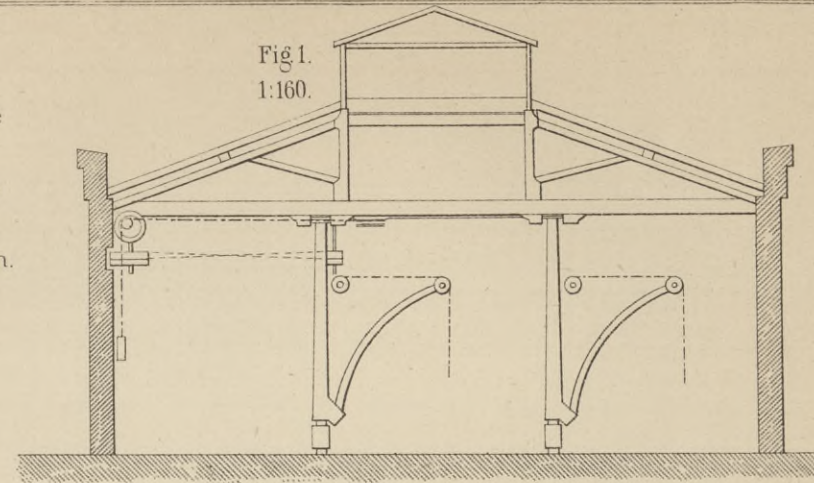
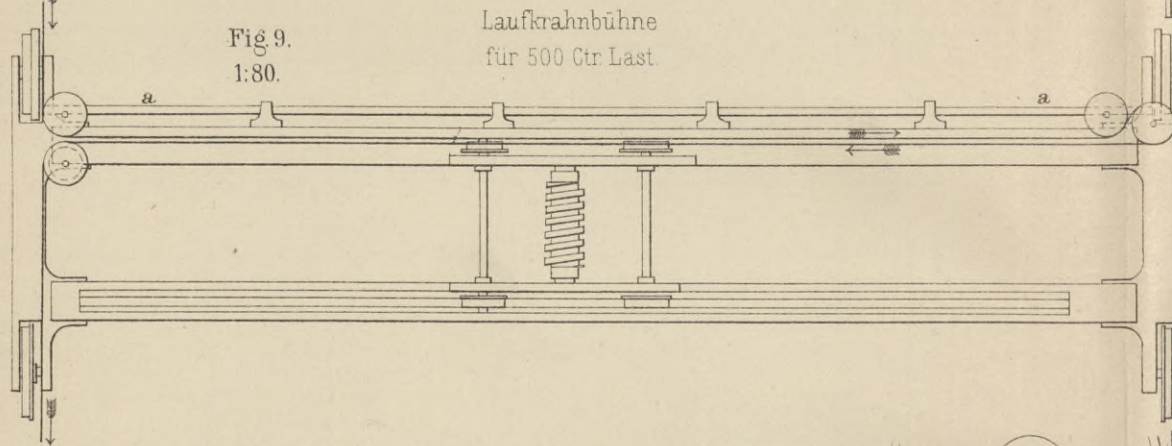

Fig. 9.  
1:80.

Laufkrahnbühne  
für 500 Ctr. Last.



Grundriss u. Querschnitt der Drehereiwerkstatt mit Laufkrahnanlage

Fig. 2.  
1:160.

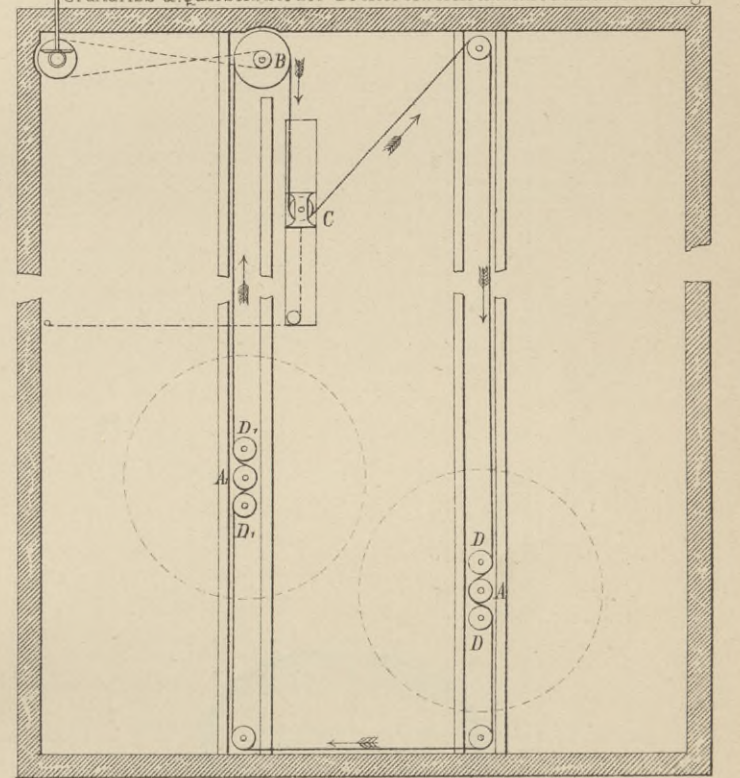

Säulenlaufkrahne für 80 Ctr

Fig. 3.  
1:50.

Fig. 4.  
1:50.

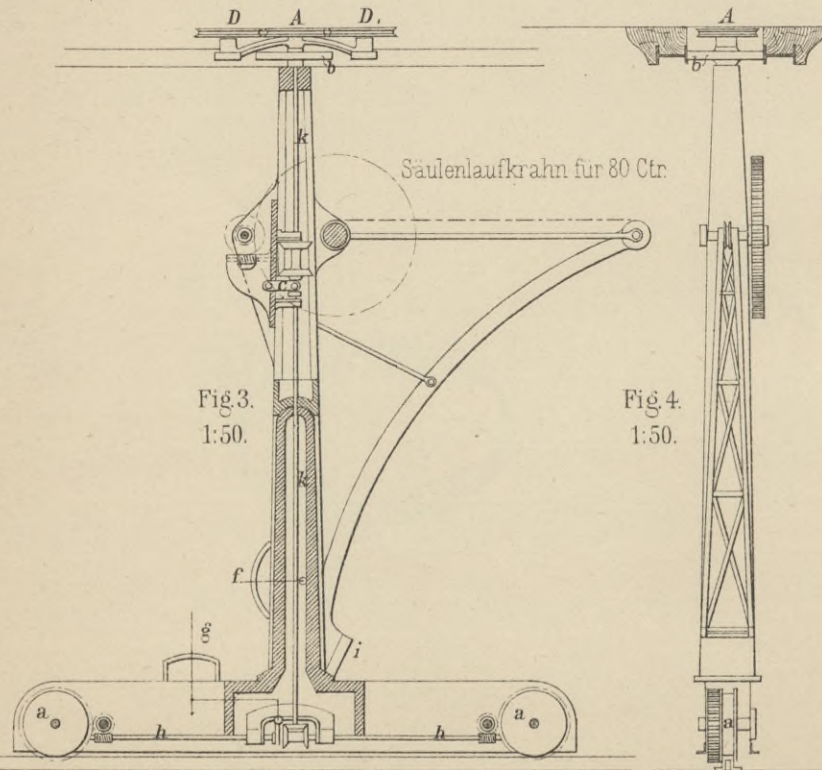
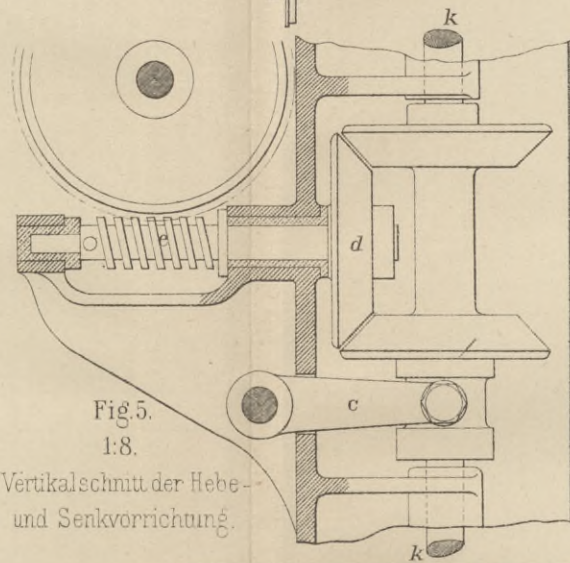

Fig. 5.  
1:8.

Vertikalschnitt der Hebe-  
und Senkvorrichtung.



Horizontalschnitt

Fig. 6.  
1:8.

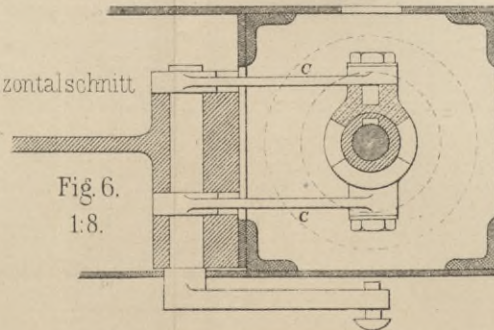

Treibapparat für die Längsbewegung

Fig. 7.  
1:8.

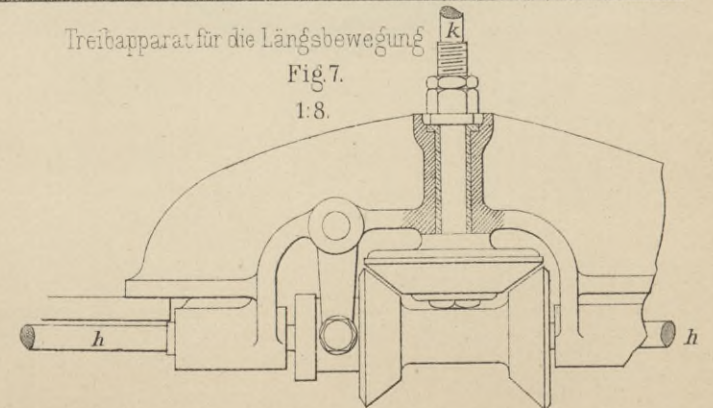

Maßstab 1:80 nat. Gr.

Maßstab 1:160 nat. Gr.

Maßstab 1:50 nat. Gr.

Maßstab 1:8 nat. Gr.







Fig 5.  
1:40

Querschnitt am Ende des Krahn.

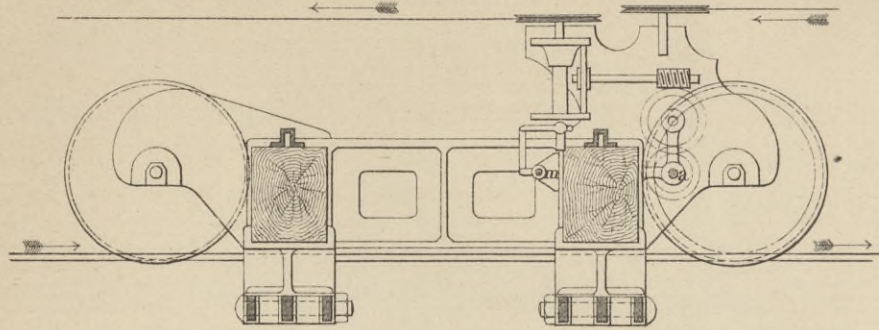

Fig 2.  
1:40.

Längenschnitt des Wagens.

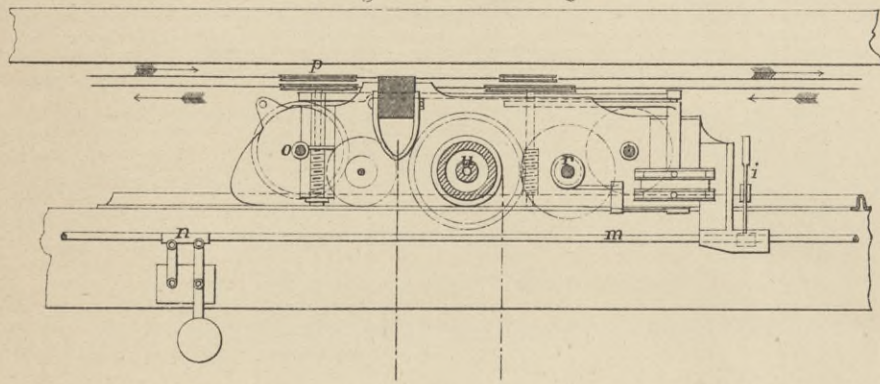

Fig 1.  
1:40

Grundriss des Wagens.

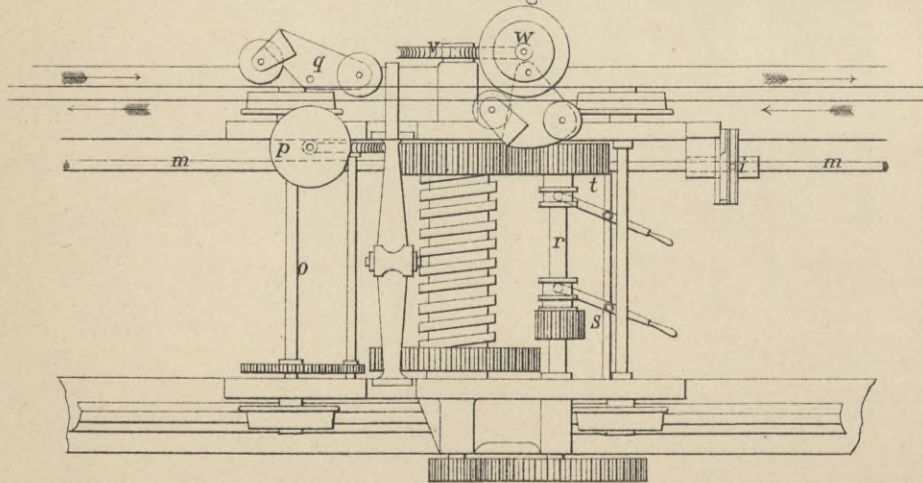

Fig 4.  
1:40

Endansicht des Wagens.

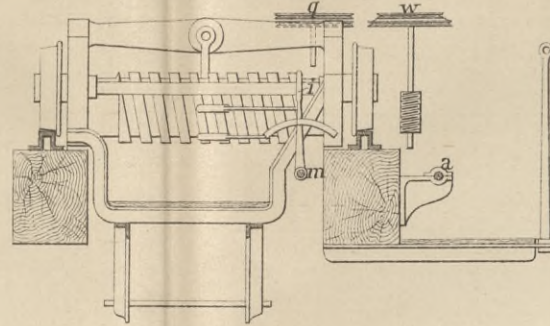

Fig 3.  
1:40

Querschnitt des Wagens.

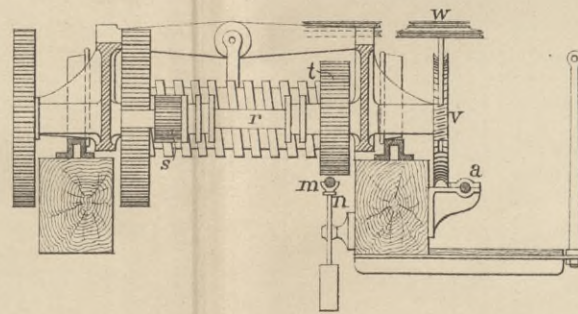
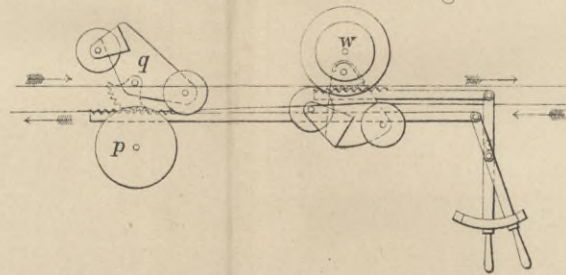

Fig 6.  
1:40

Obere Ansicht der Steuerung



Laufkrahne mit Seilbetrieb  
von  
Ramsbottom.

Mafsstab 1:40 nat Gr

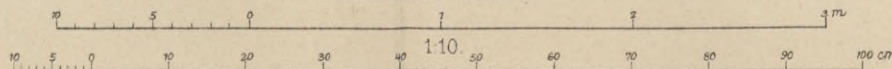

Fig 7.  
1:10.

Hebe-und Senkapparat.

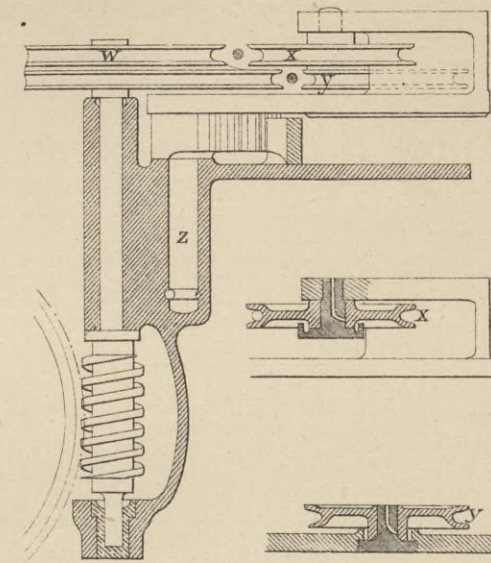

Fig 8.  
1:10.

Fig 9.  
1:10.

Treibapparat für die Längsbewegung

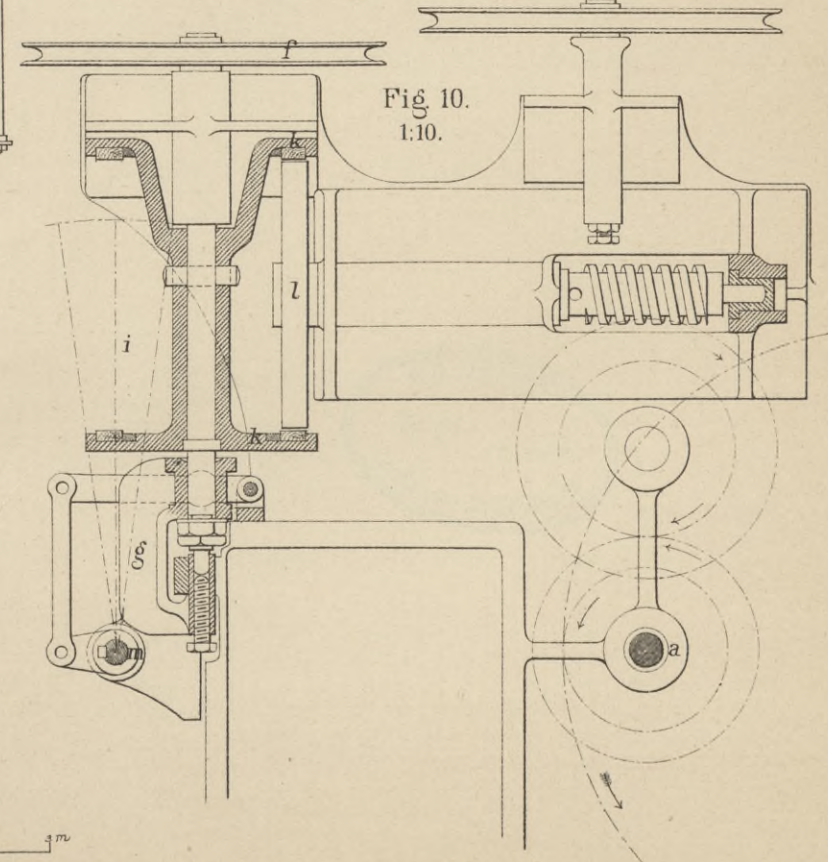

Fig 10.  
1:10.





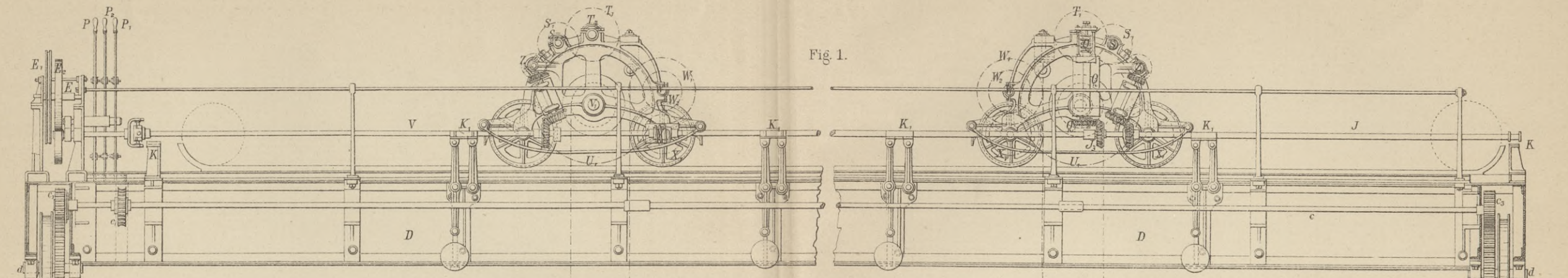

Fig. 1.

Bühnenkrahne mit Seilbetrieb

von

Sampson Moore.

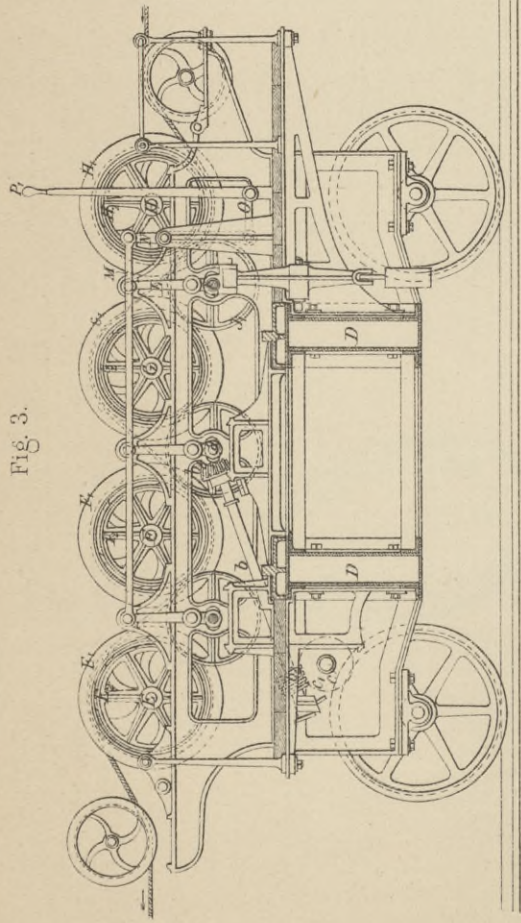

Fig. 3.

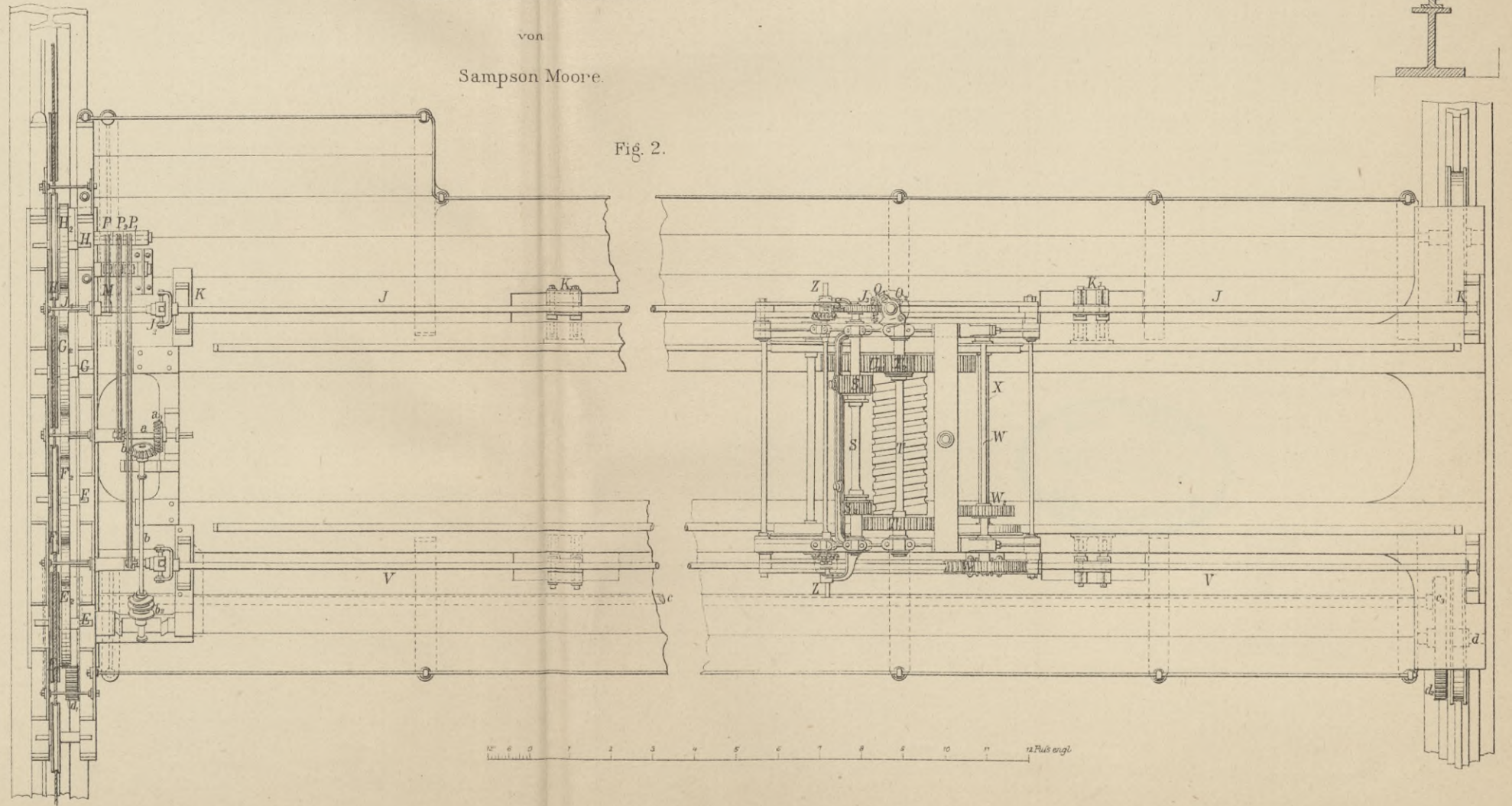

Fig. 2.

12 Fuß engl.







Hydraulischer Hebebock  
von Adamson,  
für 6000 kg Last.

Fig. 1.  
1:4.

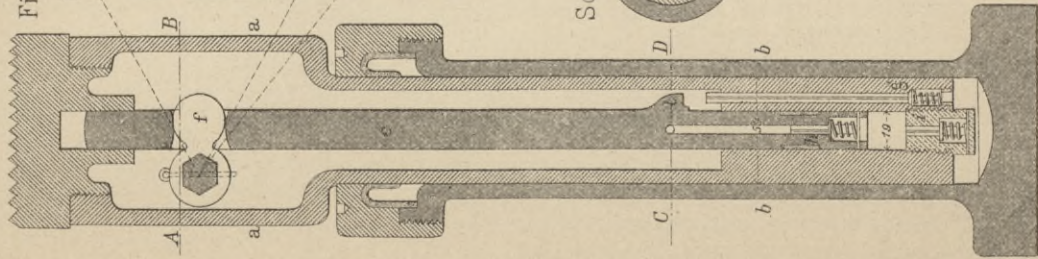

Maßstab 1:4 nat. Gr.

300 mm.

Hydraulischer Hebebock  
von Tangye,  
für 30000 kg Last.

Fig. 3.  
1:5.

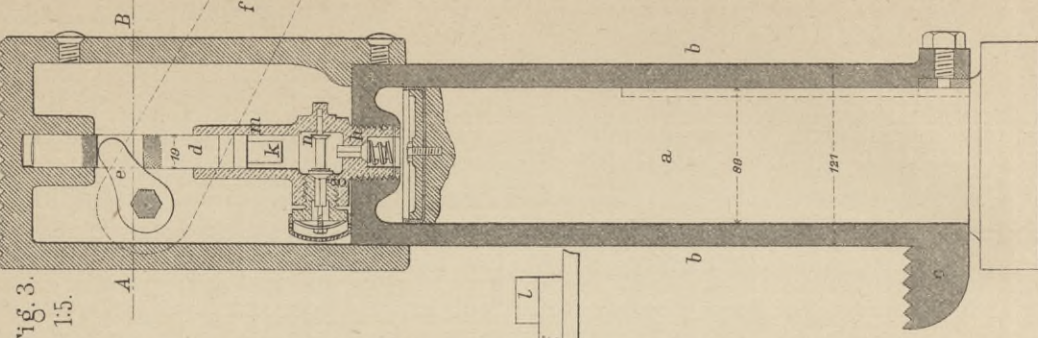

Maßstab 1:5 nat. Gr.

300 mm.

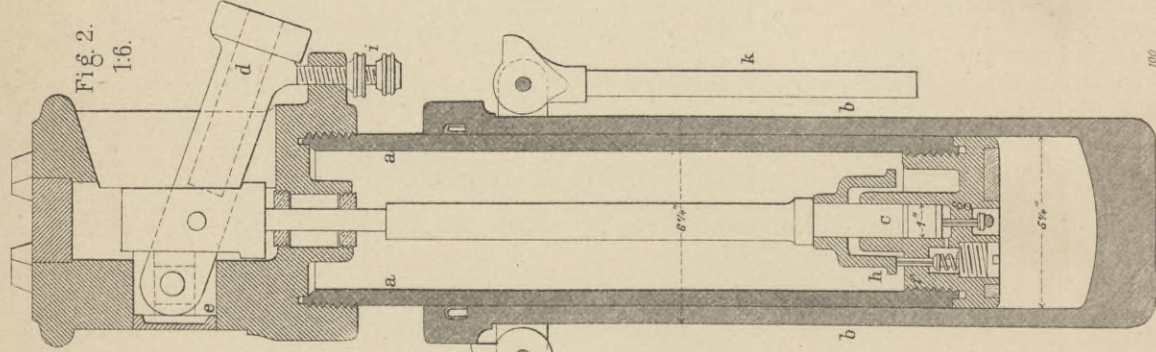

Fig. 2.  
1:6.

Maßstab 1:6 nat. Gr.

100

200

300

Fig. 4.

Hydraulischer Fahrkrahn  
von  
Ritter.  
1:32

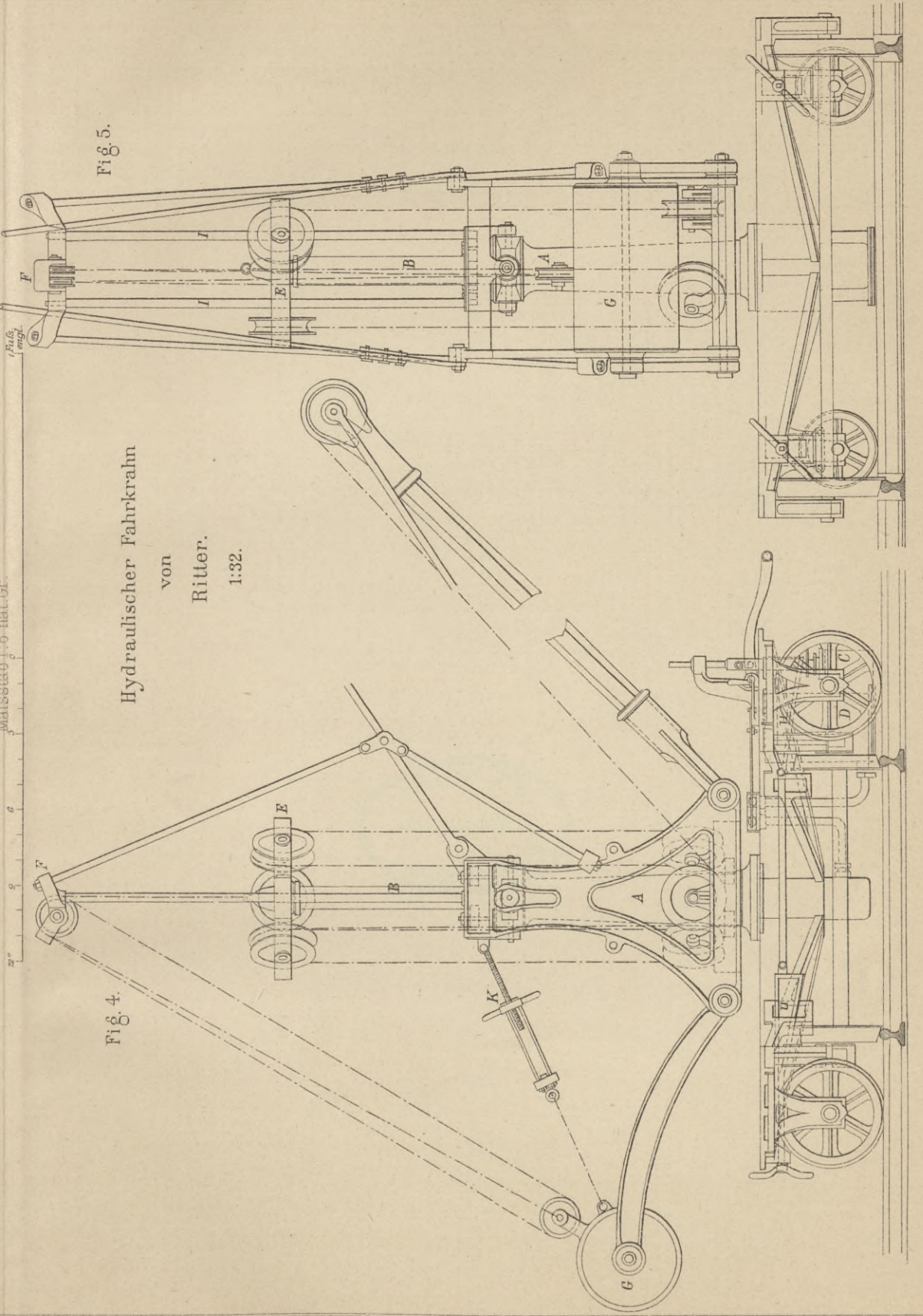

Fig. 5.

Maßstab 1:32 nat. Gr.

10

20

30

40

50

60

70

80

90

100

110

120





Hydraulischer Fahrkrahne  
von  
Ritter.

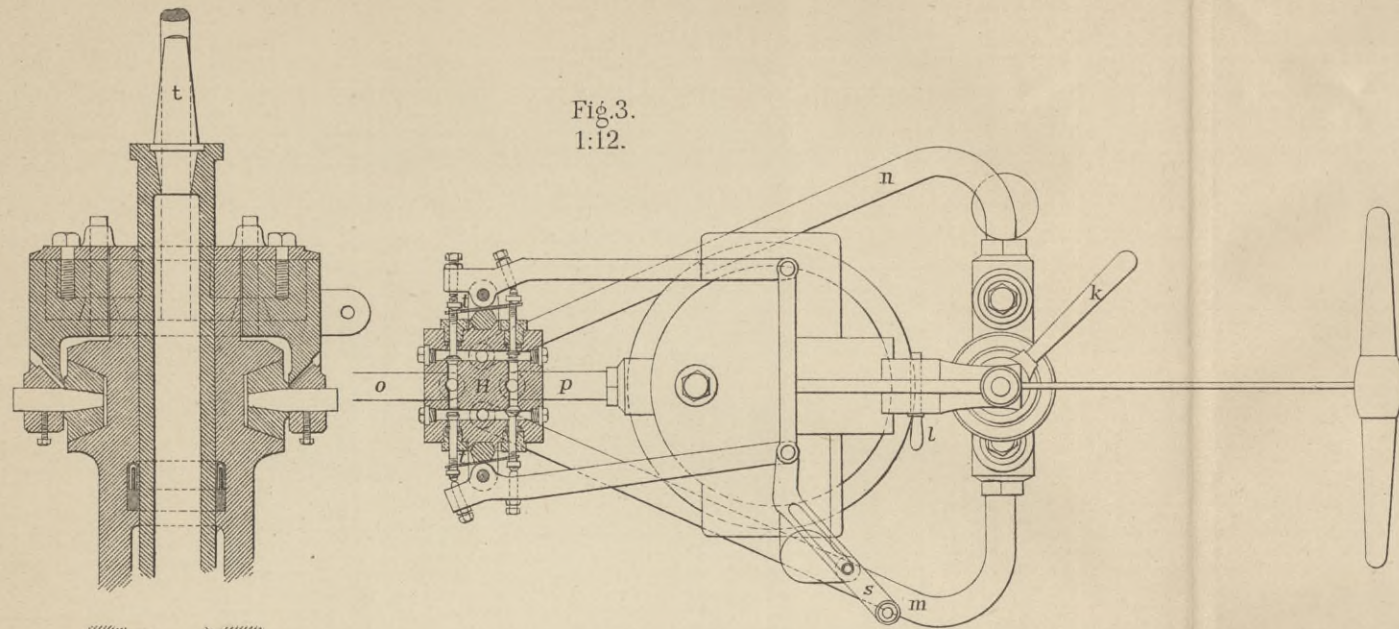

Fig. 3.  
1:12.

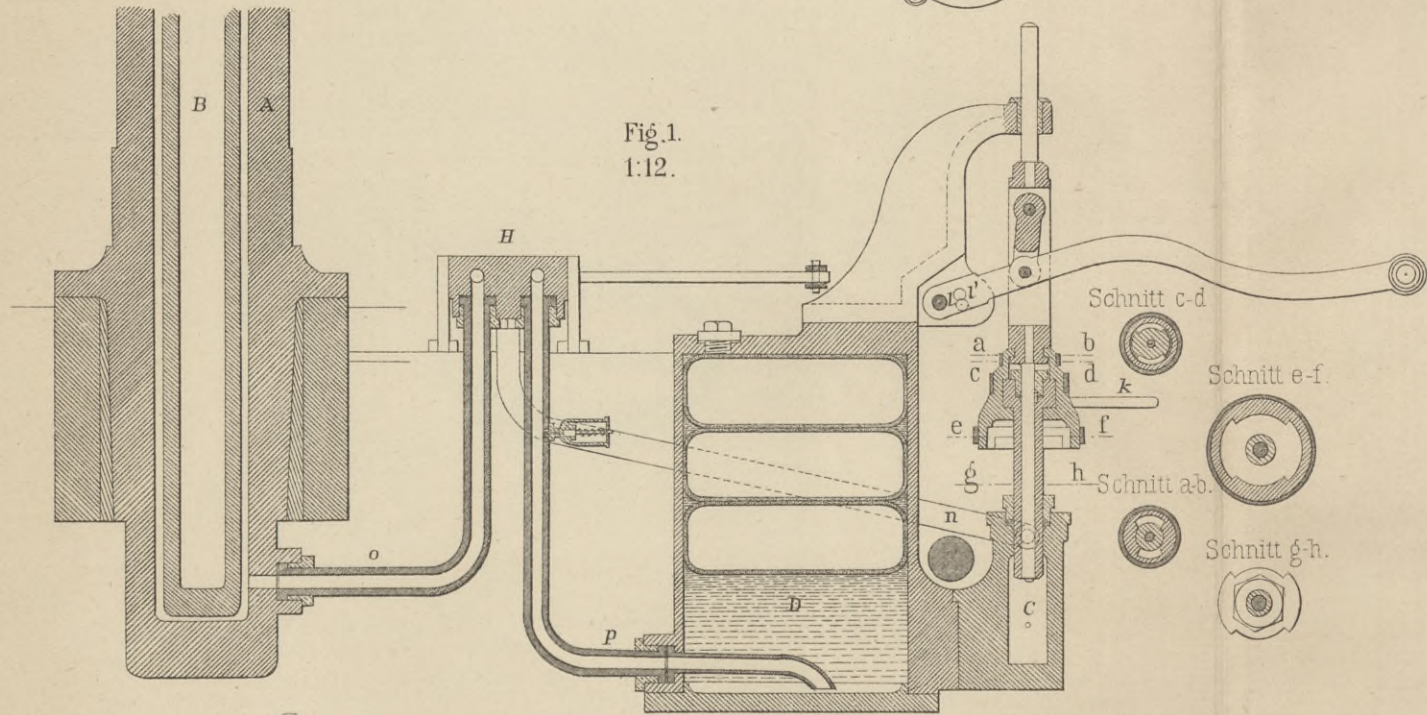

Fig. 1.  
1:12.

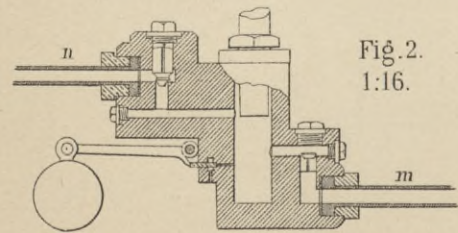

Fig. 2.  
1:16.

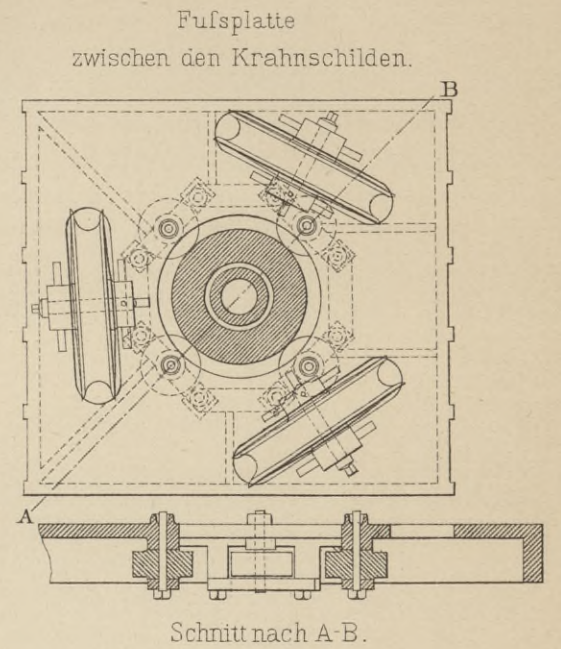
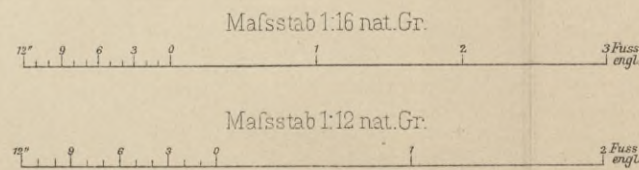
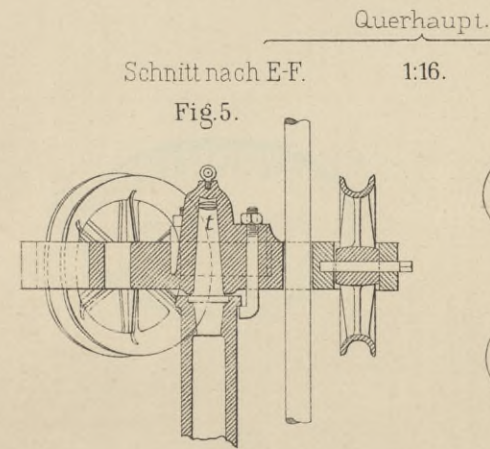

Fig. 6.  
1:16.



Schnitt nach E-F.  
Fig. 5.  
1:16.

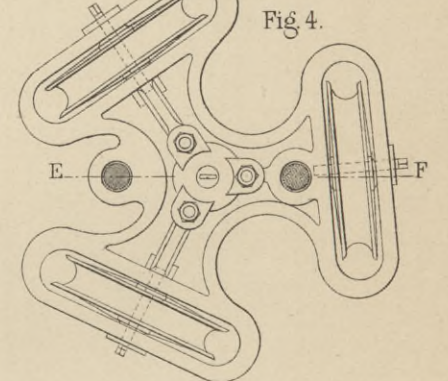

Fig. 4.

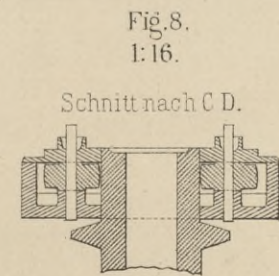

Fig. 8.  
1:16.

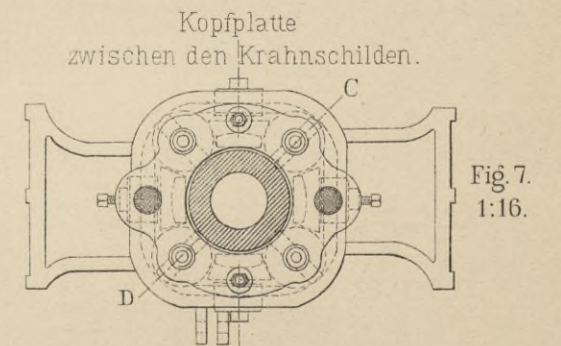
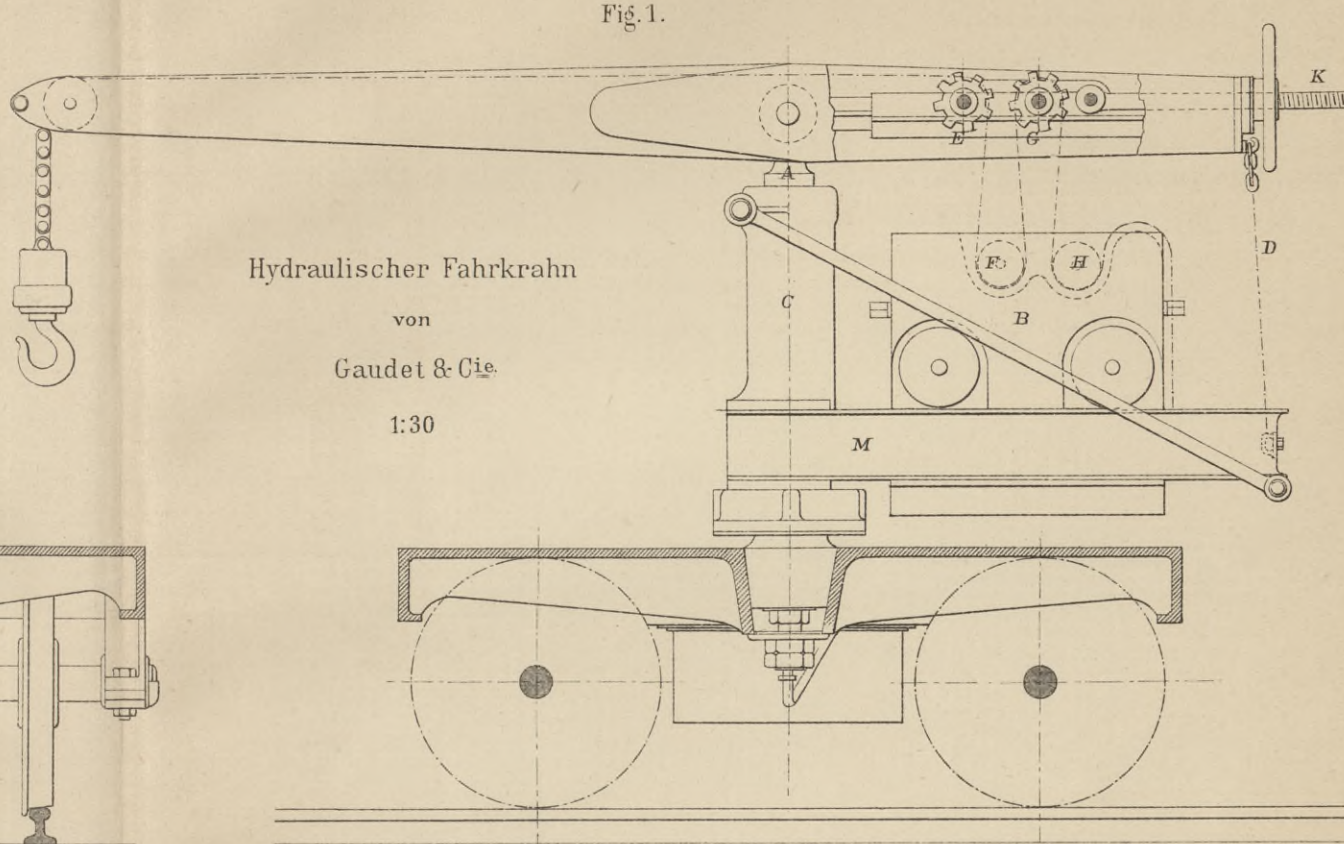
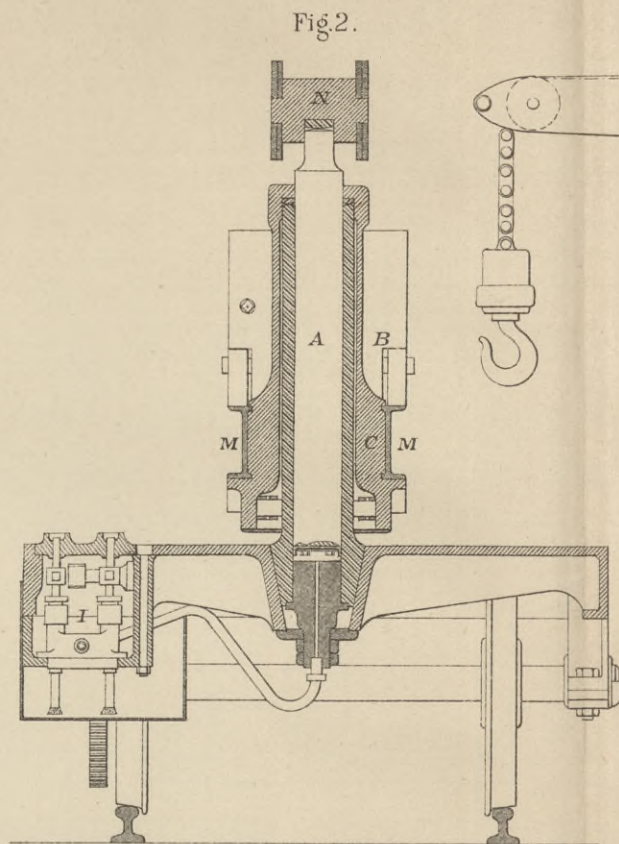
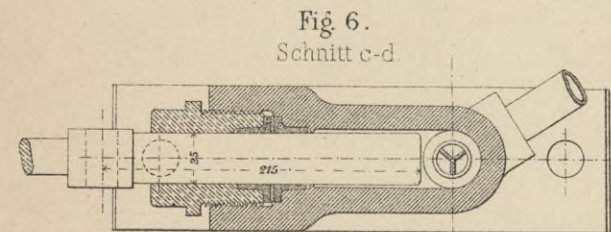
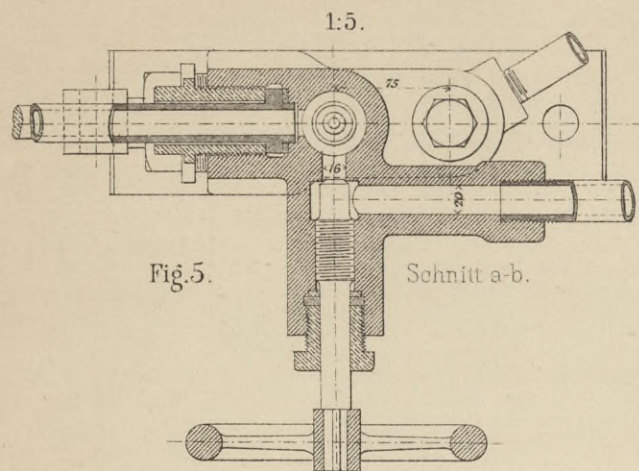

Fig. 7.  
1:16.





Pumpe.  
Details zu Gruson's Krahn.



Hydraulischer Fahrkrah

von  
Gaudet & Cie.

1:30

Fig. 7.

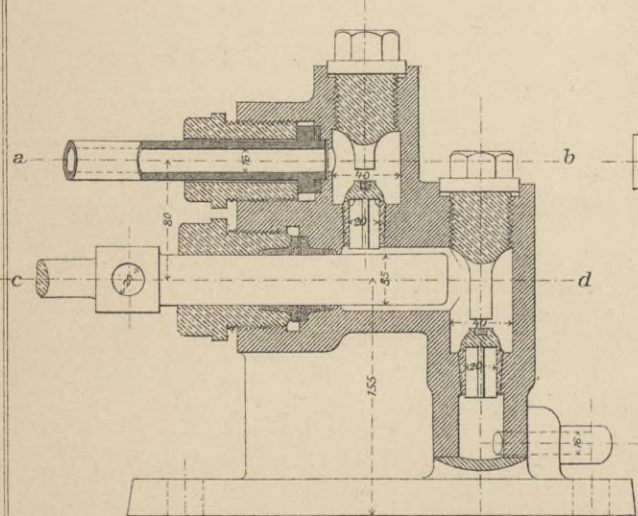

Fig. 8.

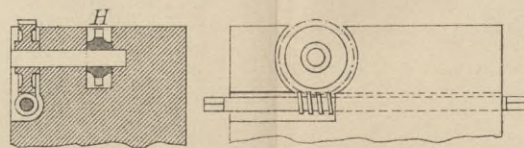
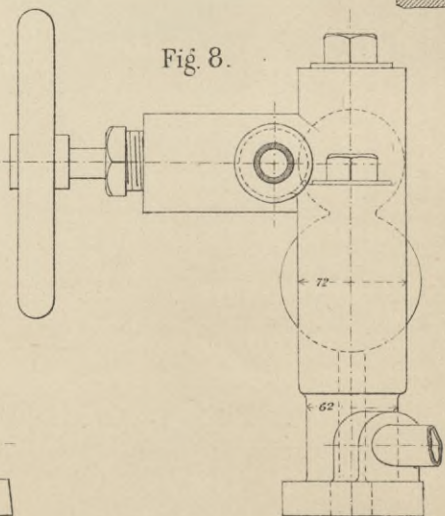
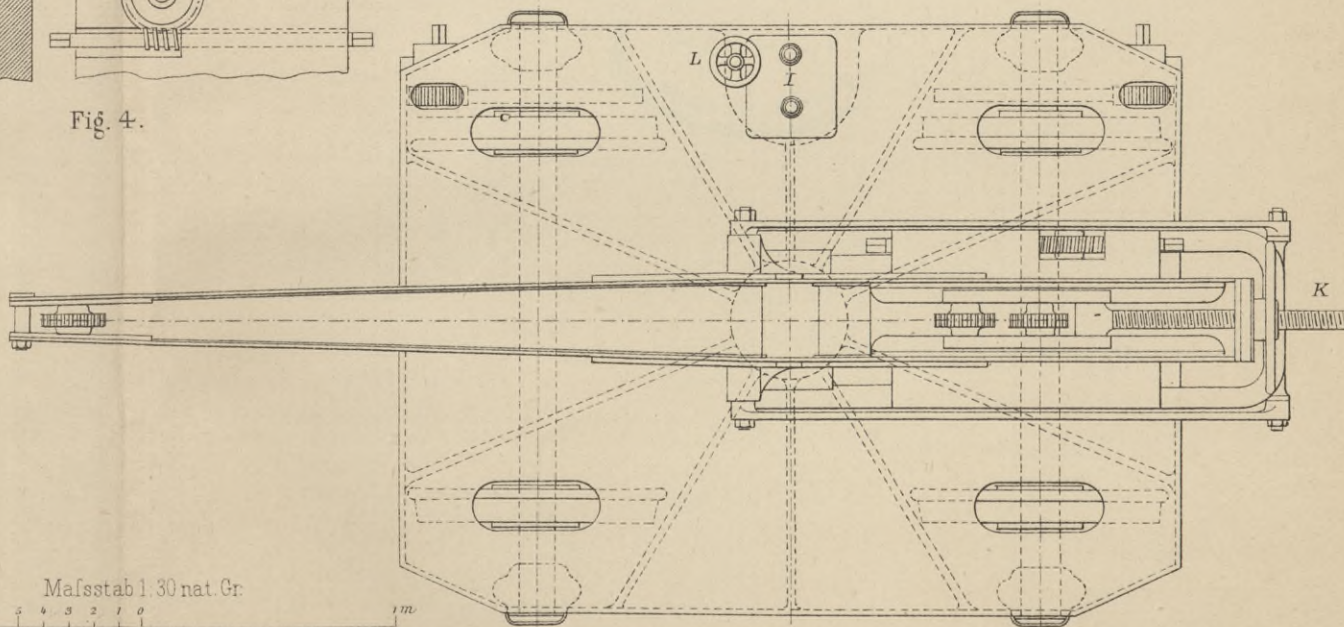

Fig. 4.

Fig. 3.



Masstab 1:30 nat. Gr.

Masstab 1:5 nat. Gr.

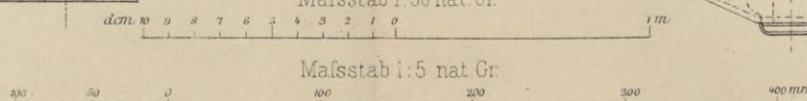







Schnitt a-b

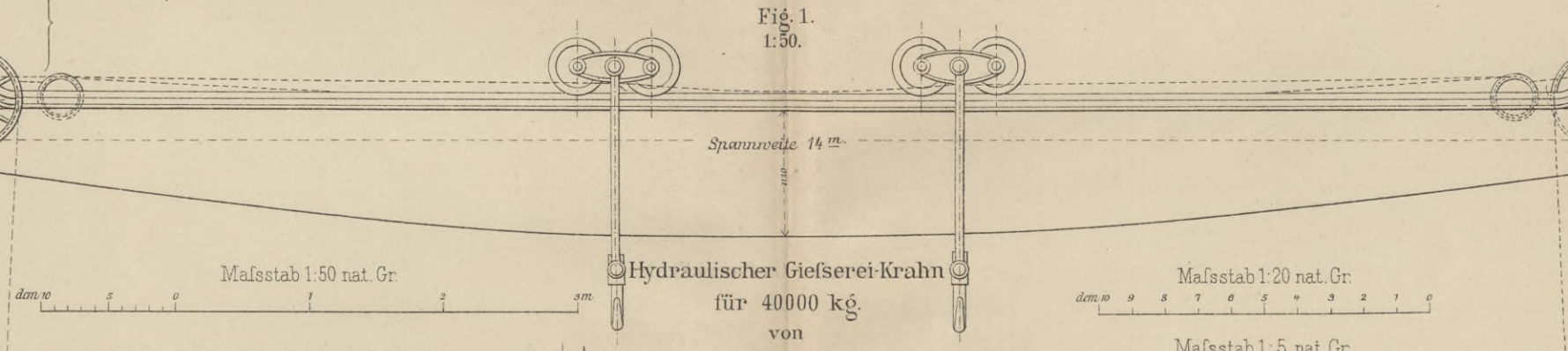
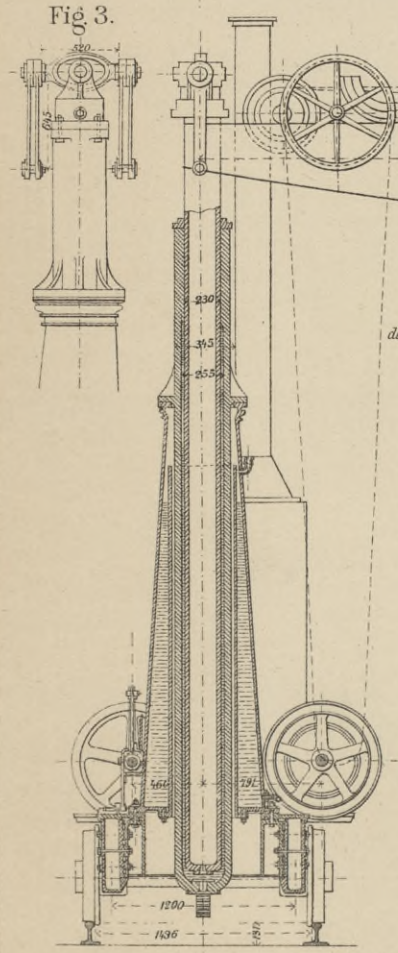
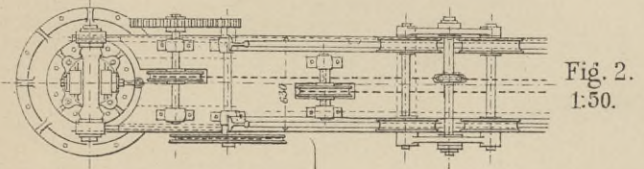
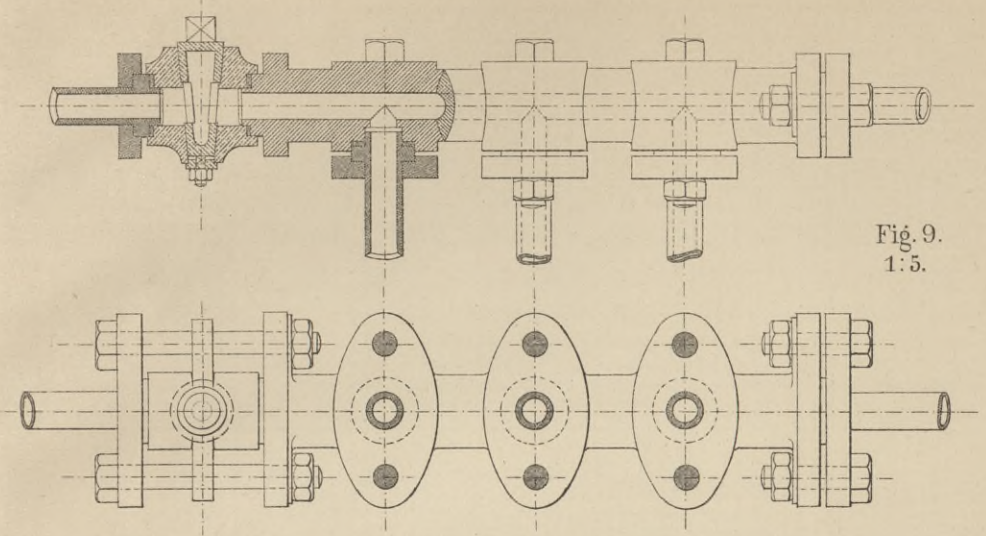
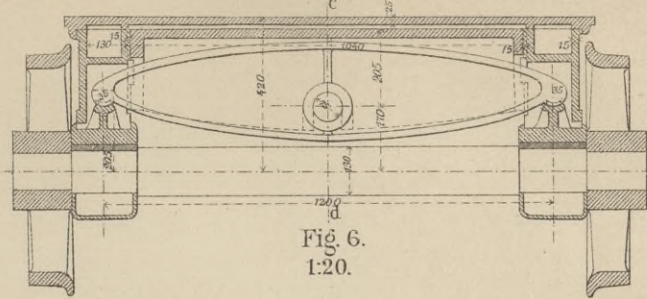
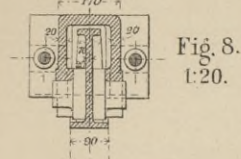
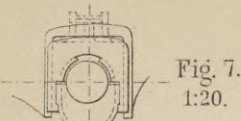

Hydraulischer Gießerei-Krahn für 40000 kg. von Gruson.

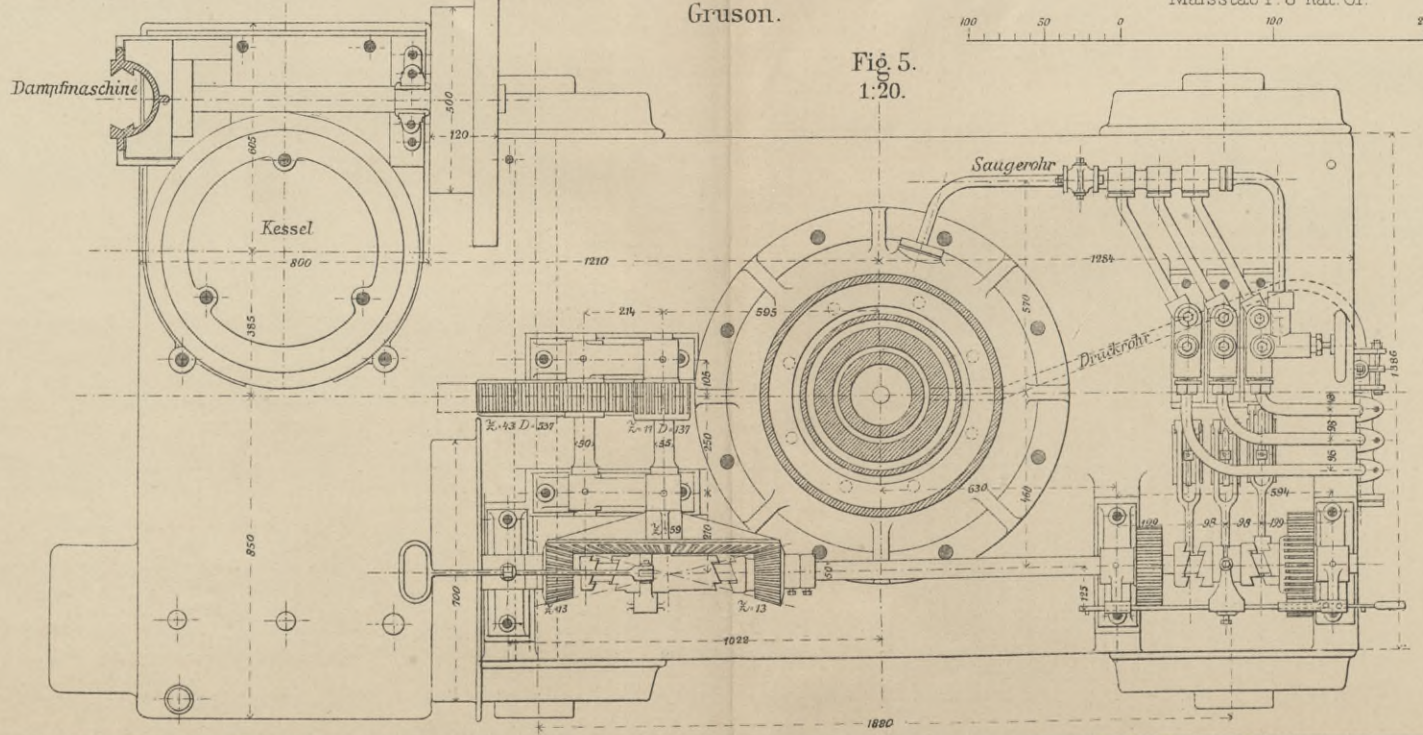
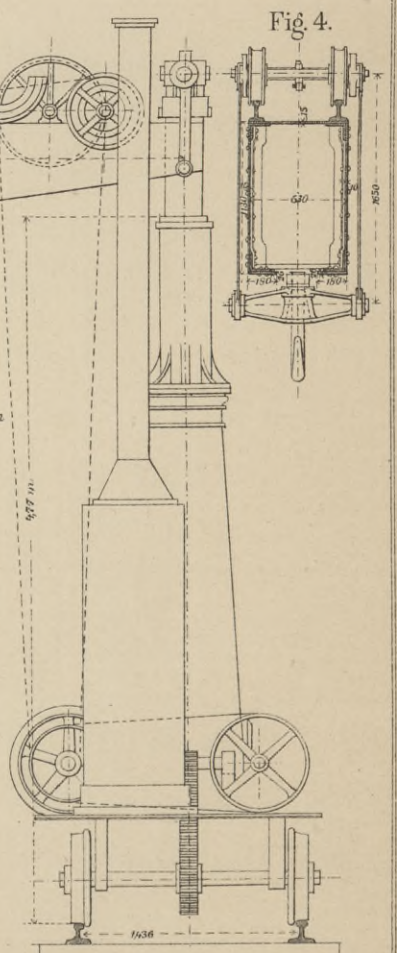





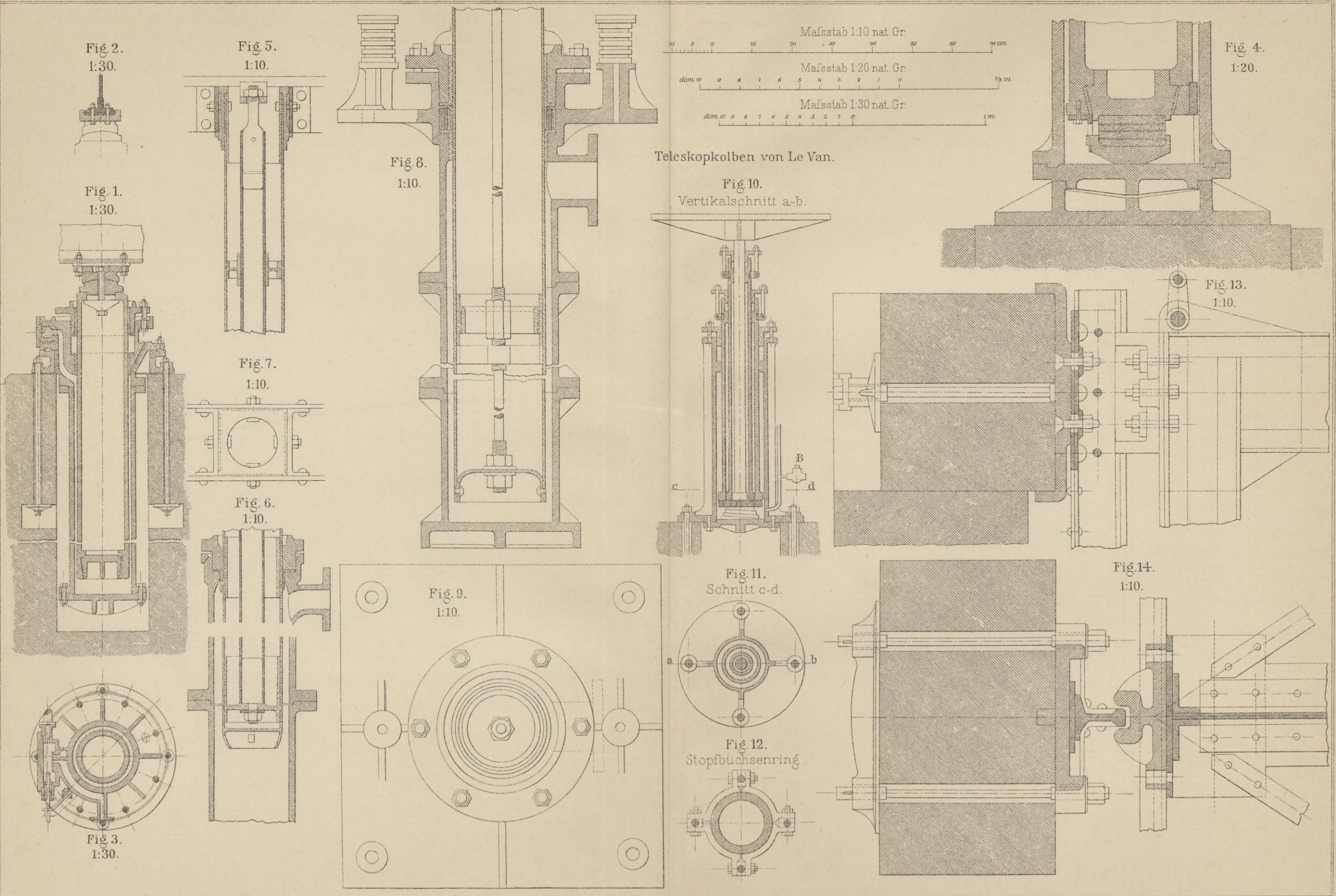





Arretirungs-Mechanismus für die einzelnen Stockwerke. 1:4.

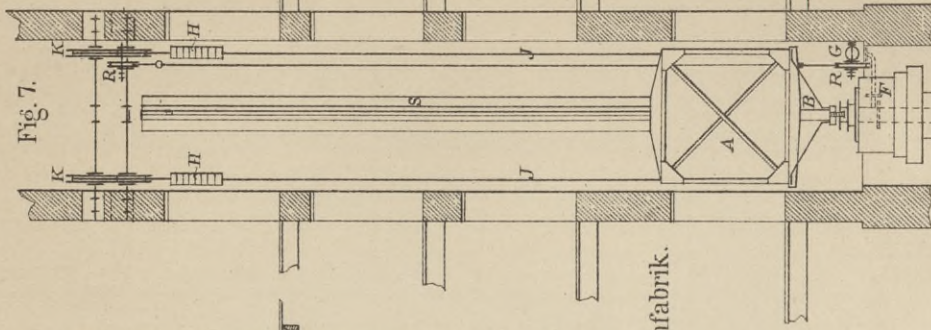
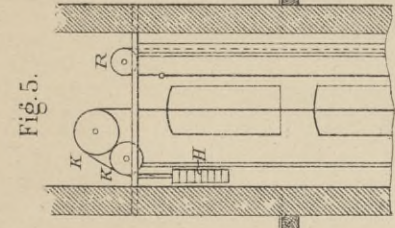
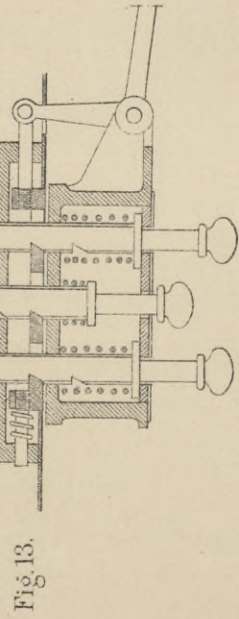
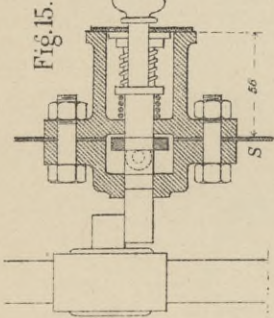
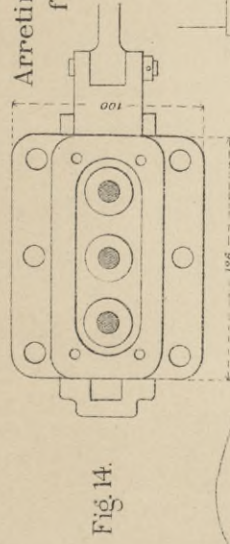

Personenaufzug für das Eisenbahn-Hôtel zu Berlin, ausgeführt in der Berlin-Anhaltischen Maschinenfabrik. 1:150.

Hydraulischer Personenaufzug von Heurtebise.

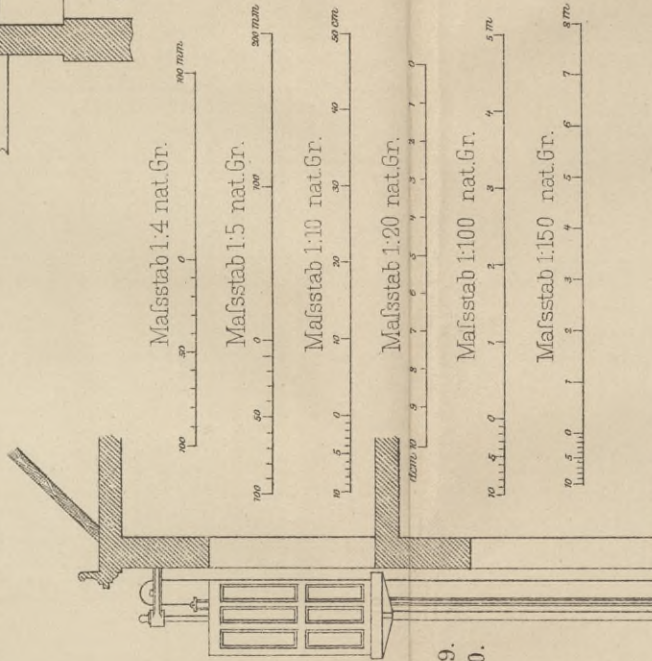
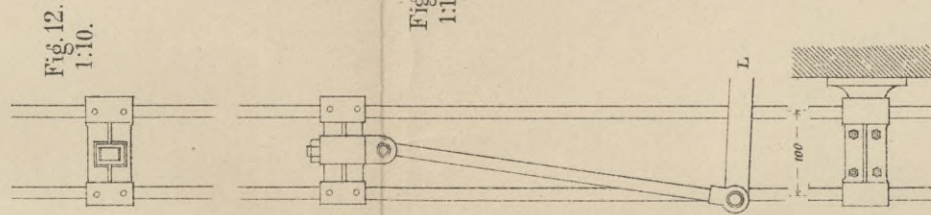
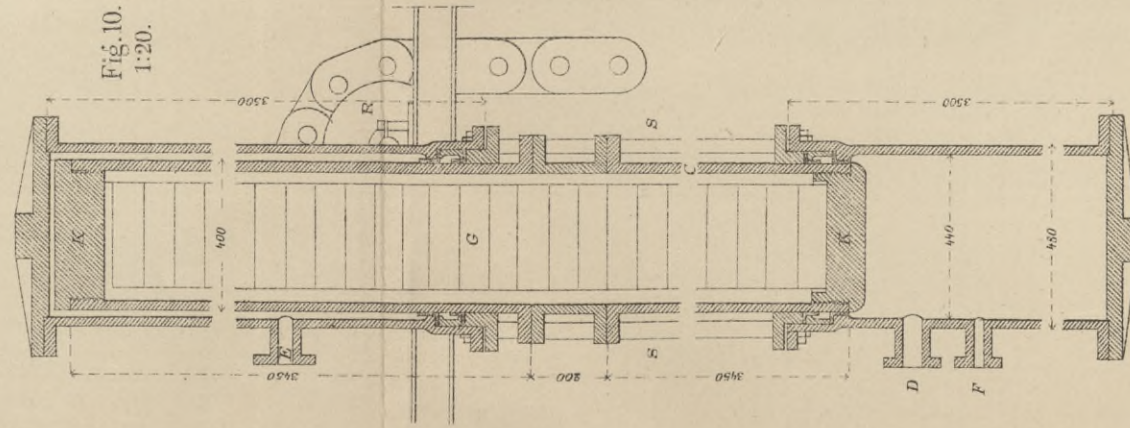

Maßstab 1:4 nat.Gr.  
Maßstab 1:5 nat.Gr.  
Maßstab 1:10 nat.Gr.  
Maßstab 1:20 nat.Gr.  
Maßstab 1:100 nat.Gr.  
Maßstab 1:150 nat.Gr.

Fig. 10. 1:20.

Fig. 12. 1:10.

Fig. 9. 1:100.

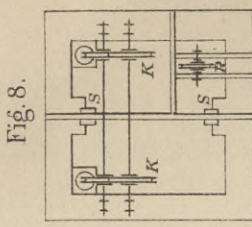
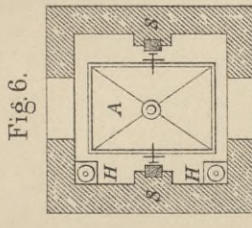

Rollenführung 1:5.

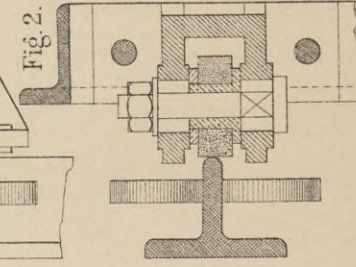
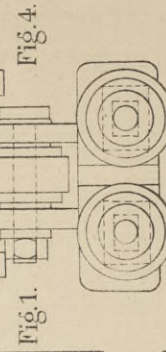
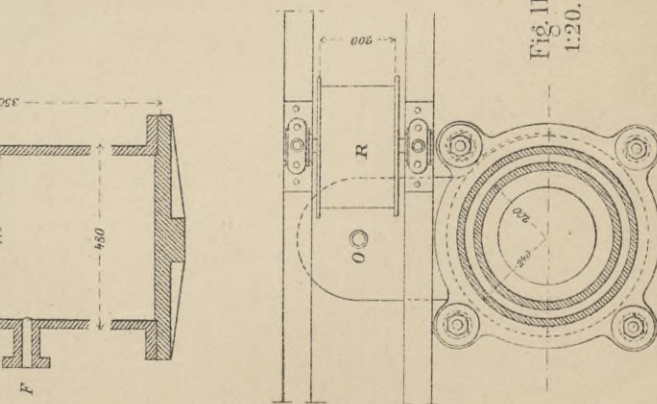
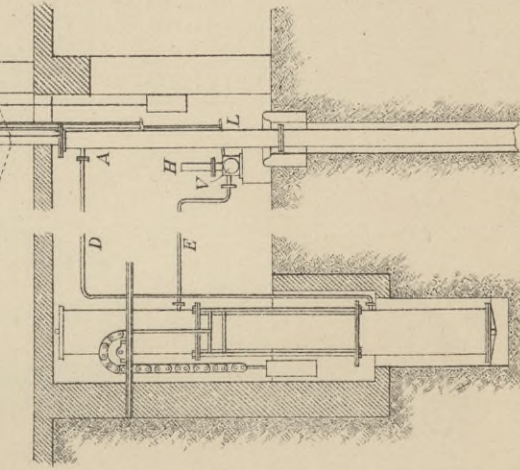
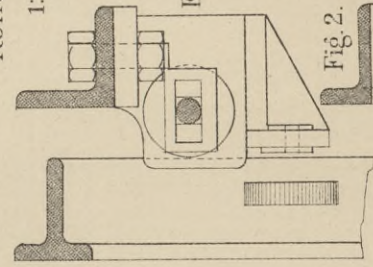

Fig. 11. 1:20.







### Hydraulische Maschine für Lastenaufzüge von Lane & Bodley in Cincinnati.

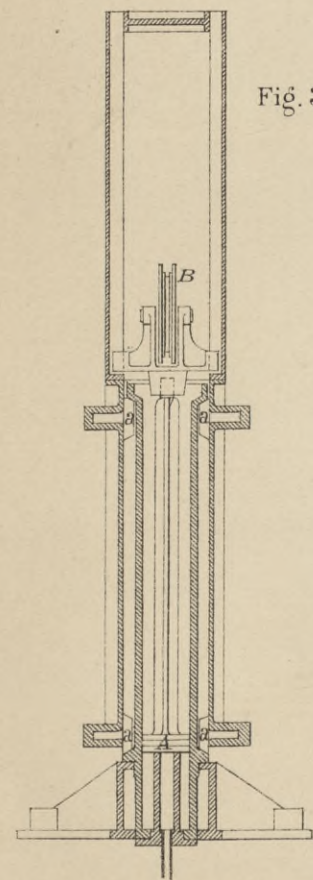
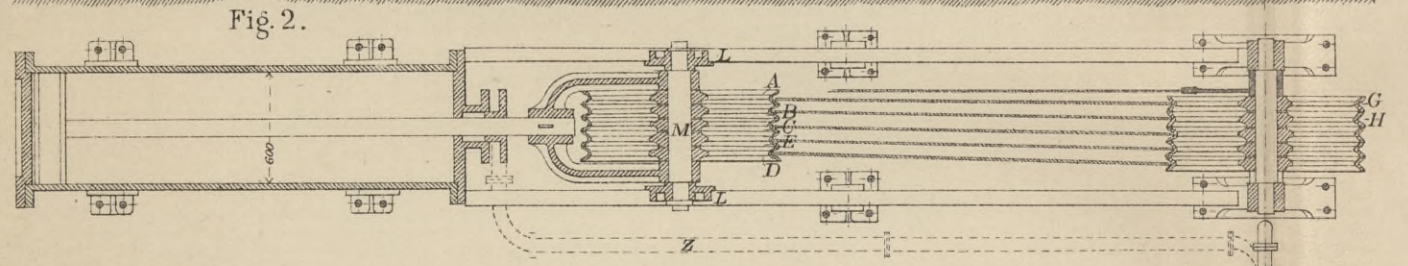
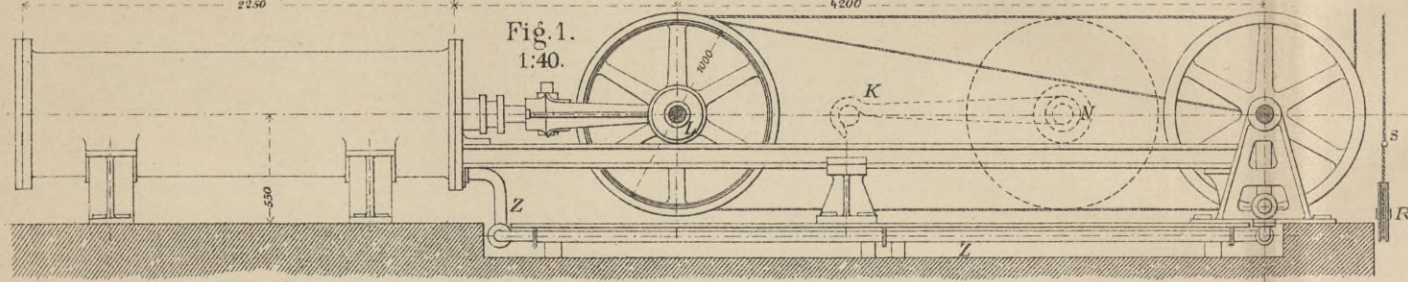

Fig. 3.

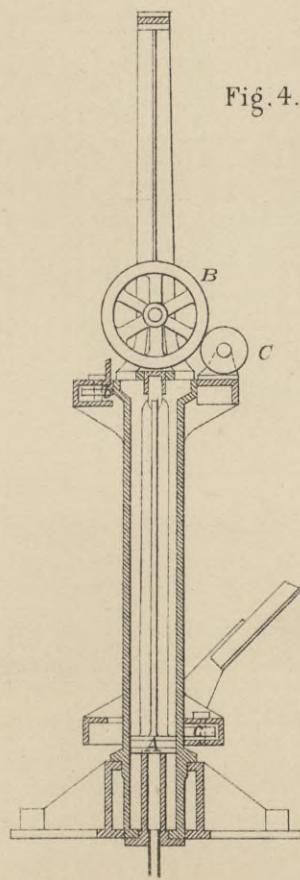

Fig. 4.

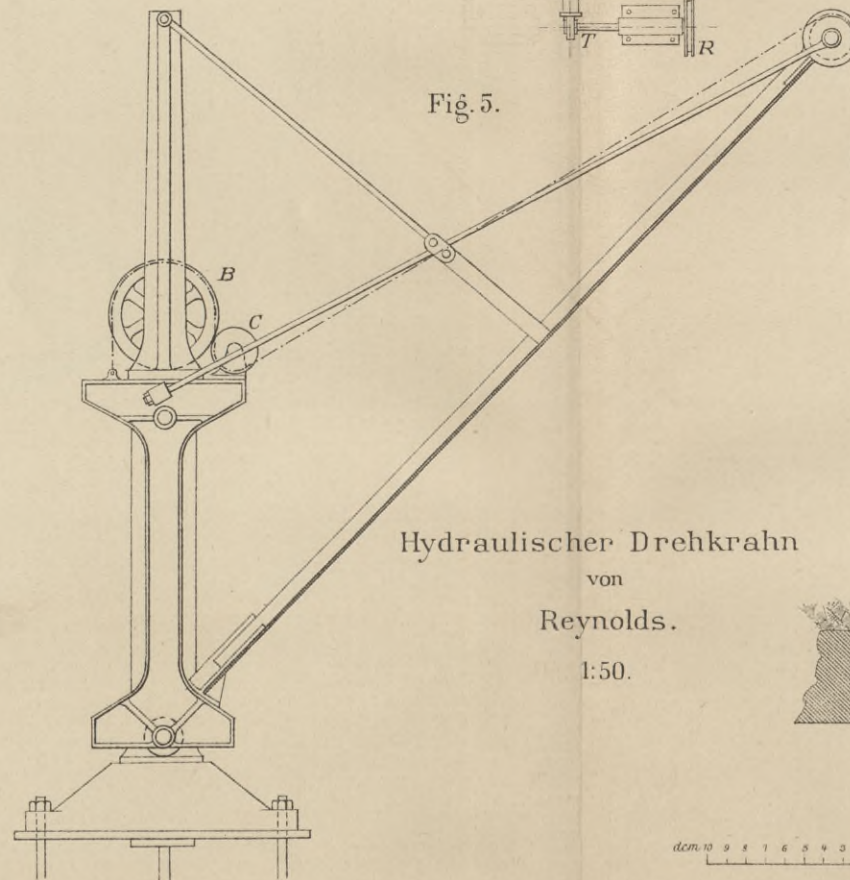

Fig. 5.

### Hydraulischer Drehkrahnen von Reynolds. 1:50.

### Hydraulischer Krahnen für Befsemer Anlagen. 1:50

1:50

Fig. 6.

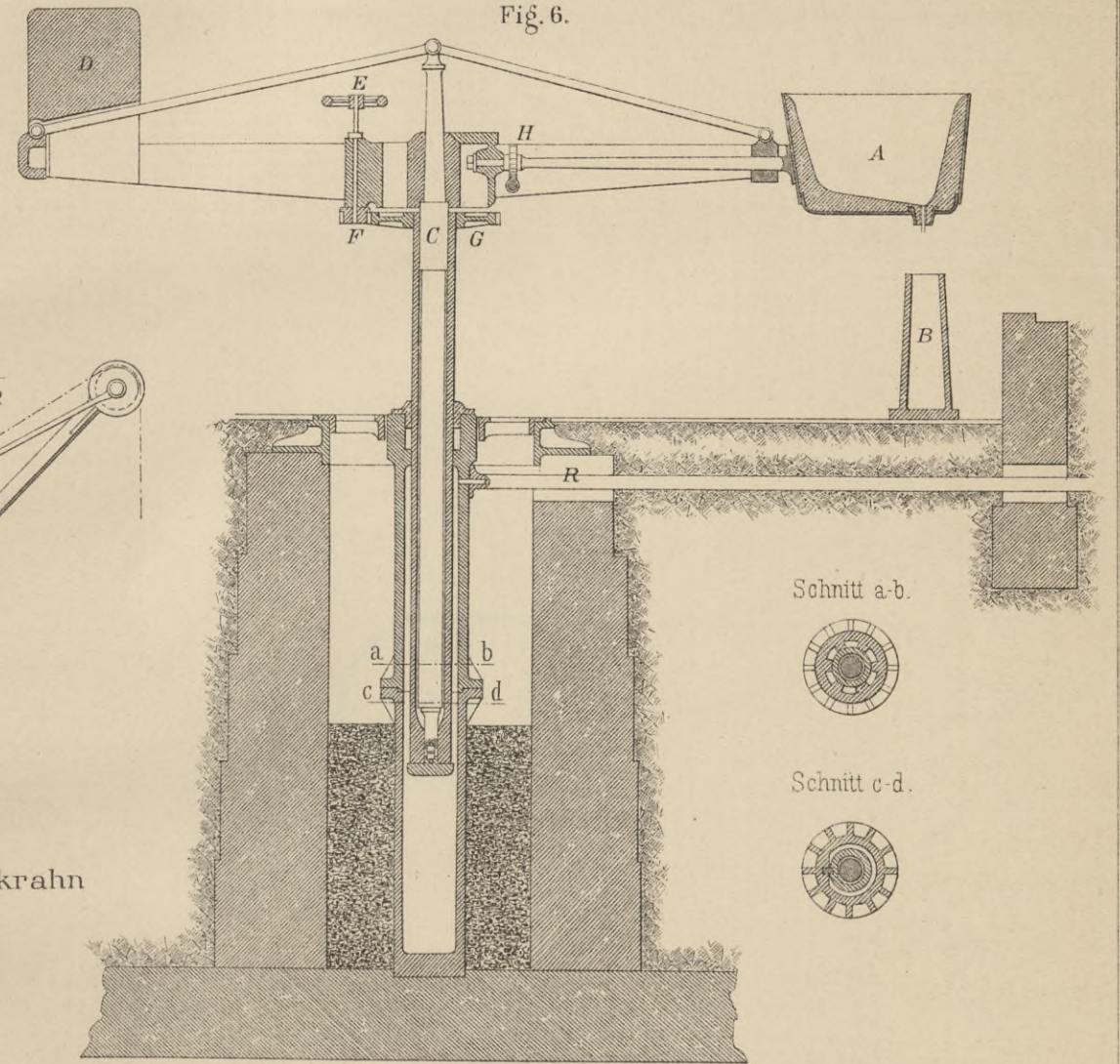

Schnitt a-b.

Schnitt c-d.

Mafsstab 1:40 nat Gr

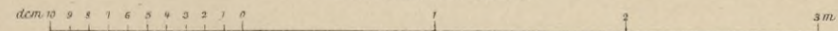

Mafsstab 1:50 nat Gr

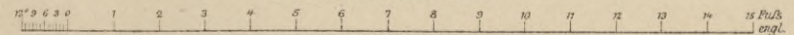





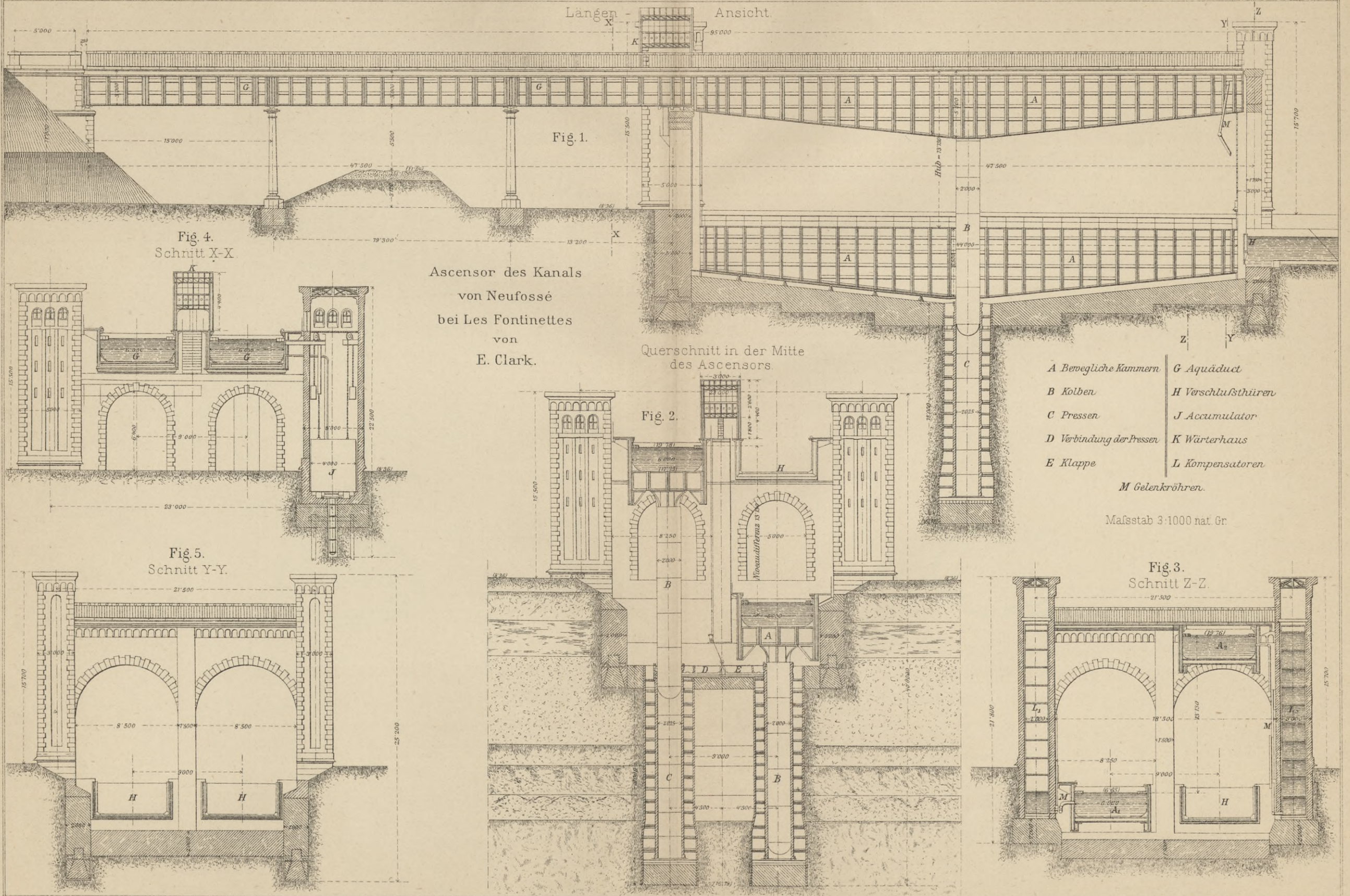













### Hydraulischer Gießerei Krahn

für  
5000 kg.  
1:50.

Fig. 1.

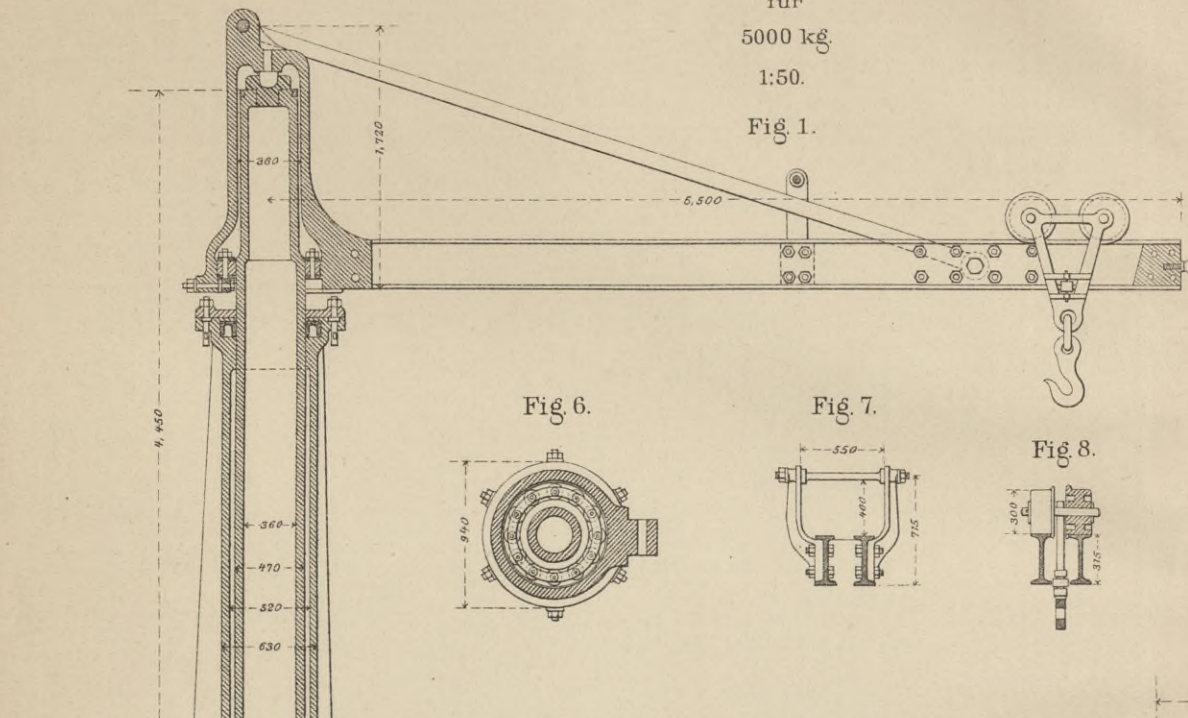

Fig. 6.

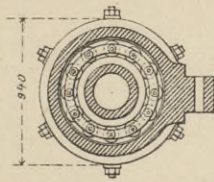

Fig. 7.

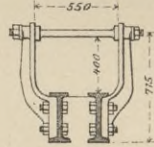

Fig. 8.

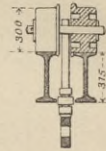

Fig. 2.

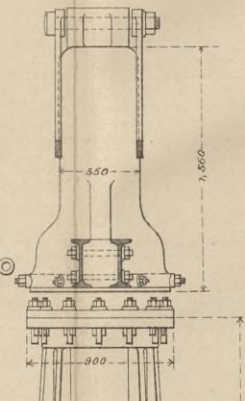

Fig. 5.

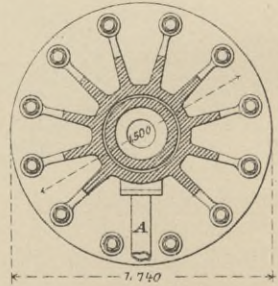

Fig. 4.

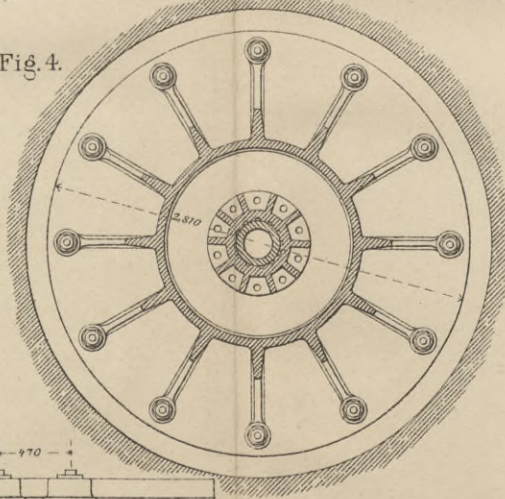
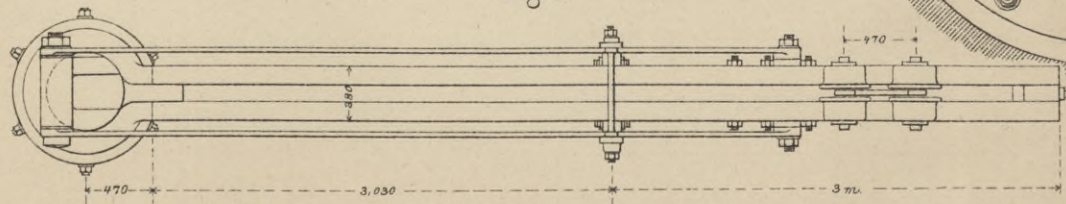
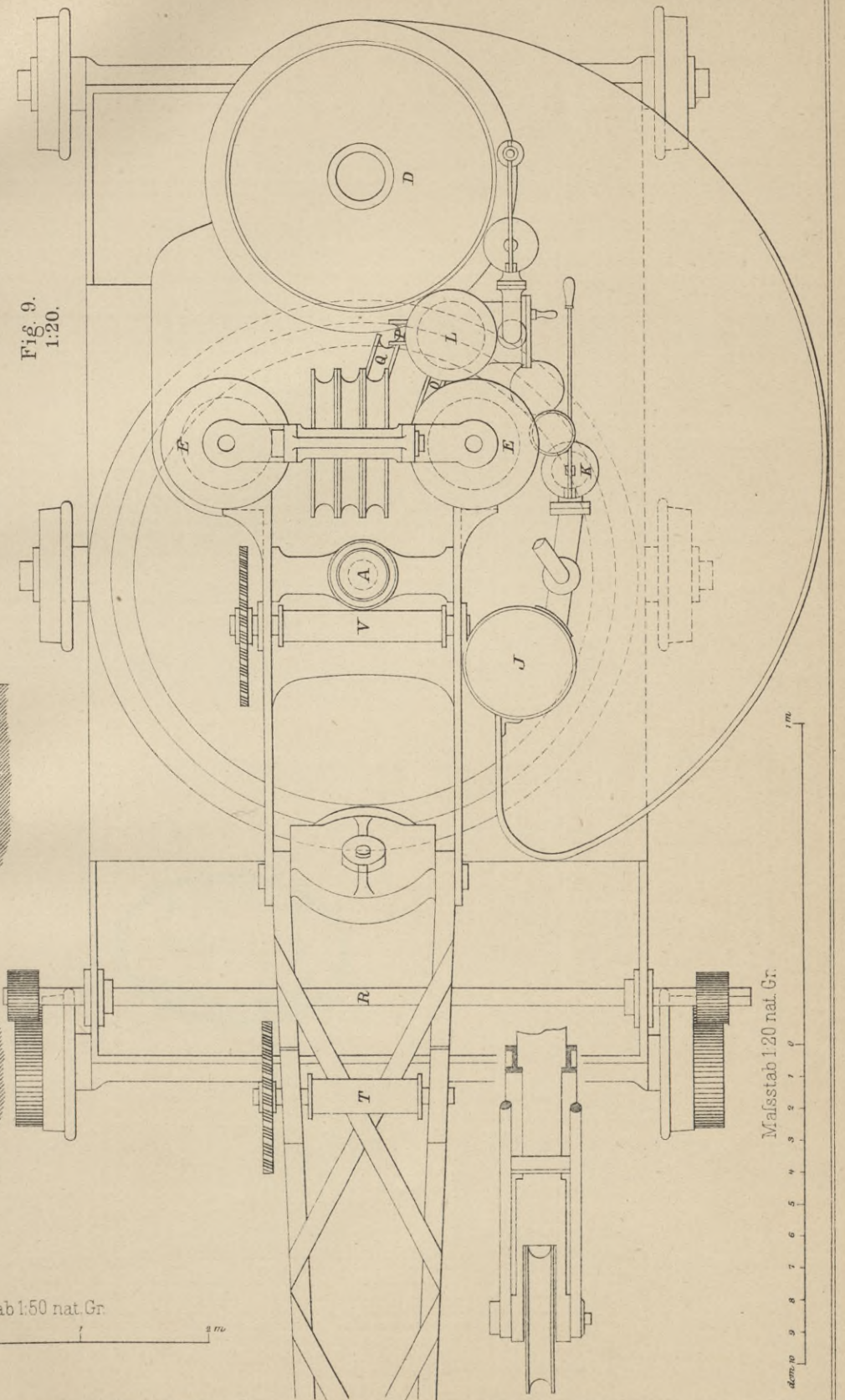

Fig. 3.



Grundriss zum Krahn von Brown & Wilson.

Fig. 9.  
1:20.



Mafsstab 1:50 nat. Gr.

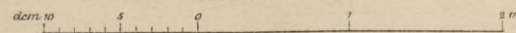

Mafsstab 1:20 nat. Gr.

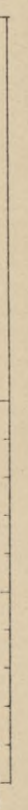

















WYDZIAŁY POLITECHNICZNE KRAKÓW

BIBLIOTEKA GŁÓWNA

Biblioteka Politechniki Krakowskiej



III-307009

Biblioteka Politechniki Krakowskiej

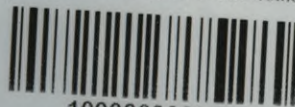

100000300382