

Hermann Fischer

Die Werkzeugmaschinen

Erster Band (Tafeln)

Biblioteka Politechniki Krakowskiej



100000300230

Fritz Müller
1900

16133
16919

DIE
WERKZEUGMASCHINEN

VON

HERMANN FISCHER

GEH. REG.-RATH U. PROF. A. D. KGL. TECHN. HOCHSCHULE ZU HANNOVER

ERSTER BAND

DIE METALLBEARBEITUNGS-MASCHINEN

(TAFELN)



BERLIN

VERLAG VON JULIUS SPRINGER

1900.

x
381



III - 206956

~~III 16133~~



Akc. Nr. ~~5176/50~~

BPK-B-134/2018

Tafelverzeichnis.

Tafel	I. Stossmaschine von Ernst Schiess in Düsseldorf Fig. 464—466 zu Seite 234		
	Stossmaschine von Droop & Rein in Bielefeld „ 468—470 „ „	236	
„	II. Liegende Stossmaschine von Ernst Schiess in Düsseldorf „	471. 472 „ „	236
„	III. Stoss- und Bohrmaschine von Ernst Schiess in Düsseldorf „	473. 474 „ „	238
„	IV. Doppelte Feilmaschine von Ernst Schiess in Düsseldorf „	478—480 „ „	241
„	V. Grubenhobelmaschine v. E. Schiess in Düsseldorf „	485. 486 „ „	247
„	VI. Blechkantenhobelmaschine von L. W. Breuer, Schumacher & Co. in Kalk bei Köln „	487. 488 „ „	249
	Besäummaschine v. Ernst Schiess in Düsseldorf „	497. 498 „ „	253
„	VII. Blechkantenhobelmaschine von L. W. Breuer, Schumacher & Co. in Kalk bei Köln „	489. 490 „ „	250
„	VIII. Tischhobelmaschine v. Droop & Rein in Bielefeld „	502—506 „ „	258
„	IX. Tischhobelmaschine von E. Schiess in Düsseldorf „	507. 508 „ „	259
„	X. Desgleichen „	510. 511 „ „	261
„	XI. Einständerhobelmaschine v. „ „ „ „ „	515—517 „ „	264
„	XII. Spitzendrehbank von Droop & Rein in Bielefeld „	553. 554 „ „	289
„	XIII. „ v. H. Wohlenberg in Hannover „	558. 559 „ „	292
„	XIV. Dieselbe „	560—563 „ „	292
„	XV. Dieselbe „	564—569 „ „	293
„	XVI. Axhalsdrehbank v. Ernst Schiess in Düsseldorf „	618. 619 „ „	320
	Plan- und Spitzendrehbank von Ernst Schiess in Düsseldorf „	570. 571 „ „	295
„	XVII. Plan- und Spitzendrehbank von Ernst Schiess in Düsseldorf „	572—574 „ „	295
„	XVIII. Geschützdrehbank v. E. Schiess in Düsseldorf „	575—577 „ „	297
„	XIX. Kurbelwellendrehbank v. E. Schiess in „	578—580 „ „	298
	Ausbohrmaschine v. H. Wohlenberg in Hannover „	661. 662 „ „	339
„	XX. Räderdrehbank von Ernst Schiess in Düsseldorf „	582. 583 „ „	301
„	XXI. Riemenrollendrehbank von H. Hessenmüller in Ludwigshafen „	585. 586 „ „	302
„	XXII. Radstern-Drehbank v. E. Schiess in Düsseldorf „	627—630 „ „	325

Tafel	XXIII.	Planscheibendrehbank von Droop & Rein in Bielefeld	Fig. 631. 632 zu Seite 327
"	XXIV.	Antrieb der Planscheibendrehbank von Droop & Rein in Bielefeld	" 633 " " 327
"	XXV.	Plandrehbank von Ernst Schiess in Düsseldorf	" 634—636 " " 328
"	XXVI.	Drehbank mit liegender Planscheibe v. Ernst Schiess in Düsseldorf	" 640. 641 " " 331
"	XXVII.	Dieselbe	" 642. " " 331
"	XXVIII.	Desgleichen, kleiner	" 643. 644 " " 332
"	XXIX.	Einständige Plandrehbank von Ernst Schiess in Düsseldorf	" 645. 646 " " 332
"	XXX.	Ausbohrmaschine von E. Schiess in Düsseldorf	" 650. 651 " " 336
"	XXXI.	" " H. Wohlenbergi. Hannover	" 656—658 " " 338
"	XXXII.	Liegende Bohr- und Fräsmaschine von Droop & Rein in Bielefeld	" 668—671 " " 345
"	XXXIII.	Desgleichen	" 672—677 " " 347
"	XXXIV.	Hilfsständer zur liegenden Bohrmaschine von Droop & Rein in Bielefeld	" 678. 679 " " 347
"	XXXV.	Liegende Bohrmaschine v. E. Schiess in Bielefeld	" 680. 681 " " 349
"	XXXVI.	Doppelte liegende Bohr- und Fräsmaschine von Ernst Schiess in Düsseldorf	" 682. 683 " " 350
"	XXXVII.	Wurmfräsmaschine v. J. E. Reinecker in Chemnitz	" 789—801 " " 424
"	XXXVIII.	Fräsmaschine mit lothrechter Spindel v. Droop & Rein in Bielefeld	" 802—806 " " 425
"	XXXIX.	Langfräsmaschine v. J. E. Reinecker in Chemnitz	" 815—820*) " " 430
"	XXXX.	Langlochfräsmaschine von Droop & Rein in Bielefeld	" 824—826 " " 435
"	XXXXI.	Fräsmaschine für Weichenzungen-Wurzeln von Droop & Rein in Bielefeld	" 837—839 " " 442
"	XXXXII.	Allgemeine Räderfräsmaschine v. Droop & Rein in Bielefeld	" 843—847 " " 446
"	XXXXIII.	Wurmfräsmaschine v. J. E. Reinecker, Chemnitz	" 849—852 " " 451
"	XXXXIV.	Blechscheere von Otto Froriep in Rheydt . .	" 985. 986 " " 534
"	XXXXV.	Blechscheere von Otto Froriep in Rheydt . .	" 988. 989 " " 534
"	XXXXVI.	Feststehende Nietmaschine v. d. Maschinenbau-A.-G., vorm. Breitfeld Danék & Co. in Prag.	" 1171—1179 " " 655

*) Auf Tafel XXXIX sind die Figuren-Nummern zu ändern: 799 in 815, 800 in 816, 801 in 817, 802 in 818, 803 in 819, 804 in 820.

Fig. 464 u. 467.
Stossmaschine von Ernst Schiess in Düsseldorf.
1/15 wahrer Grösse.

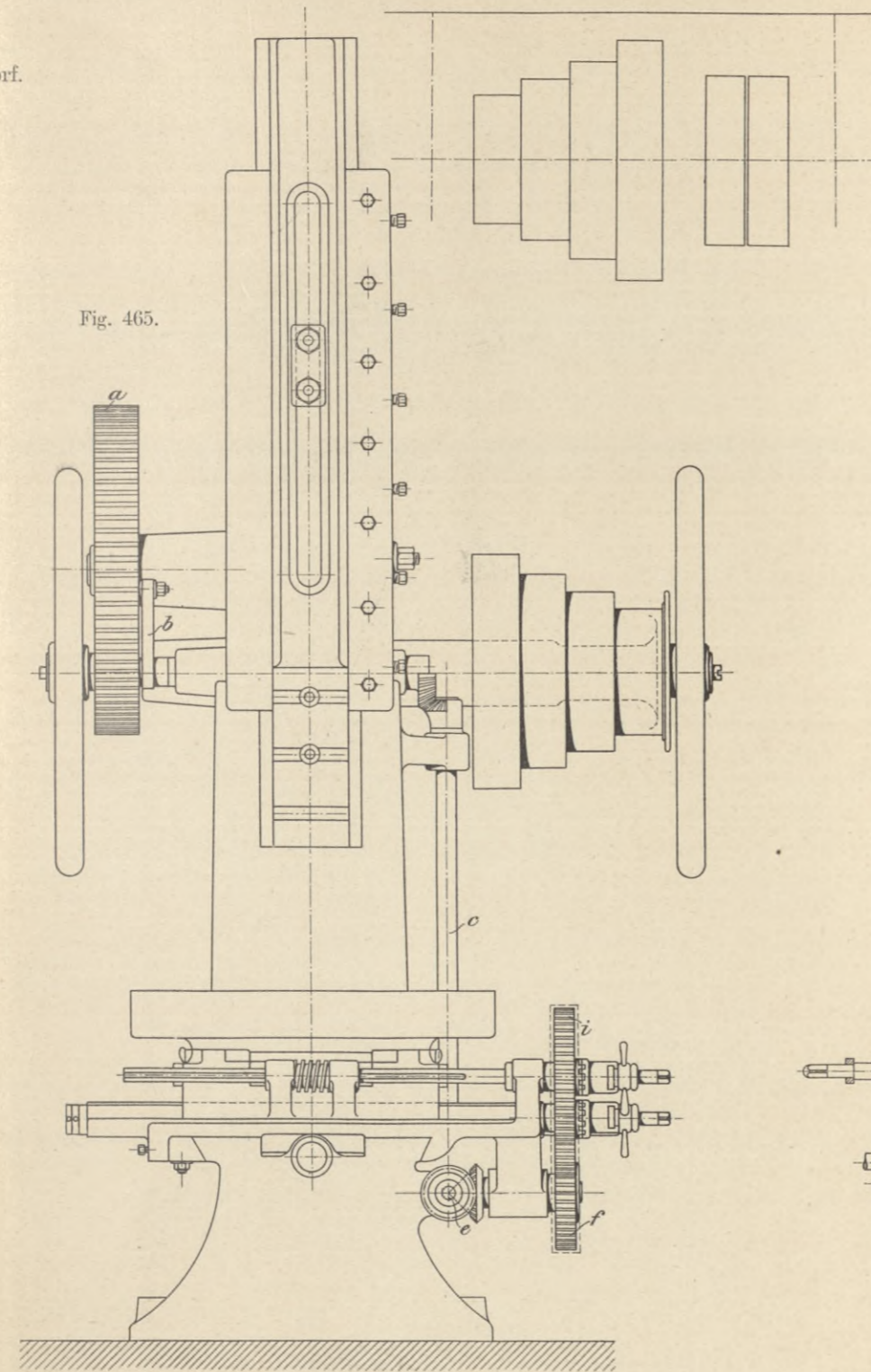
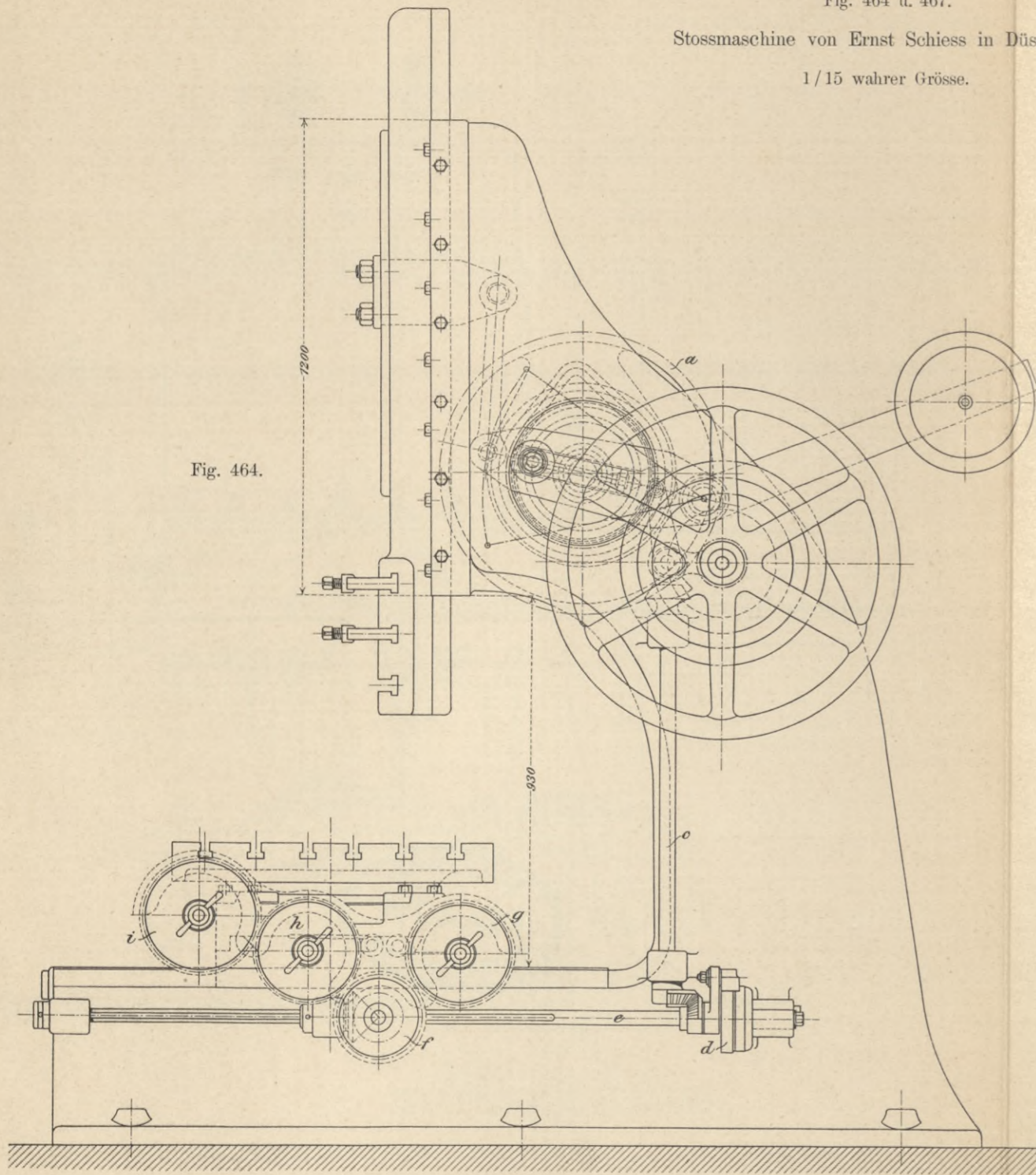
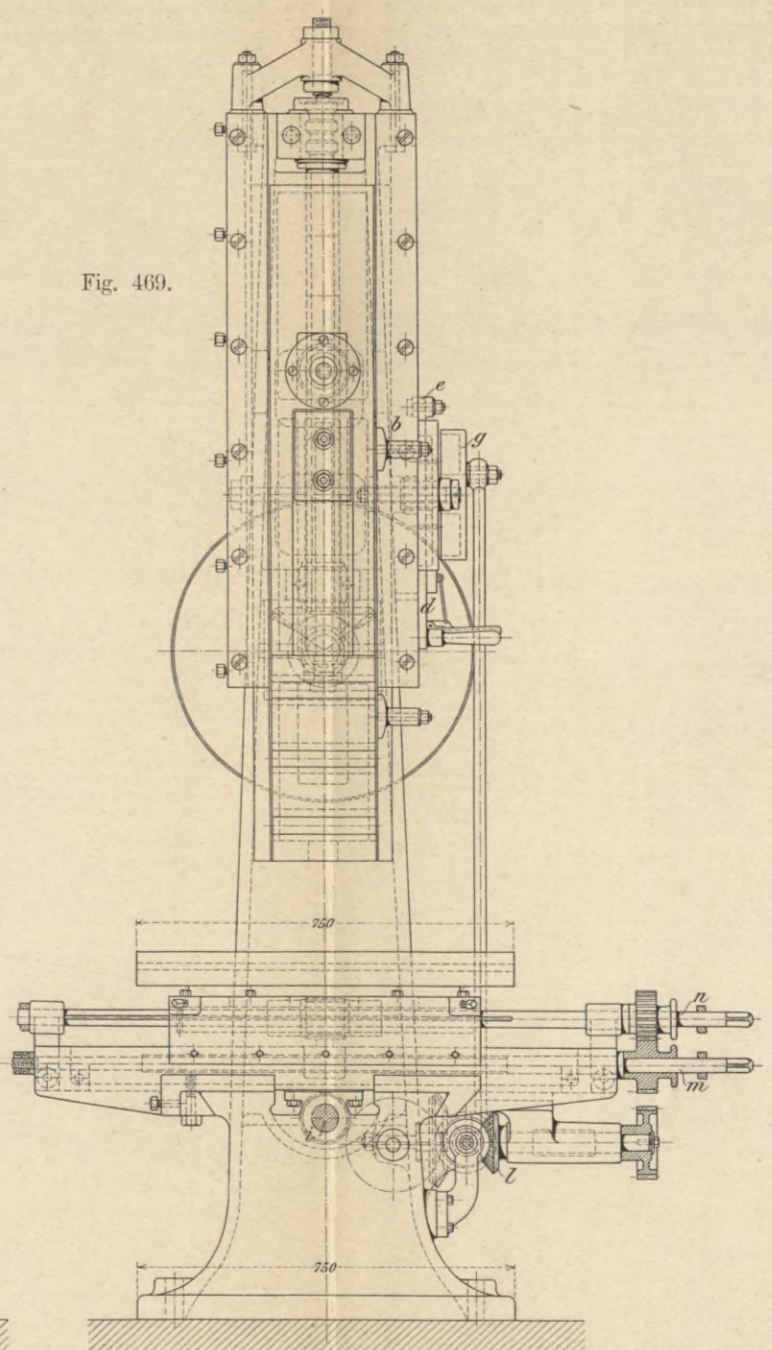
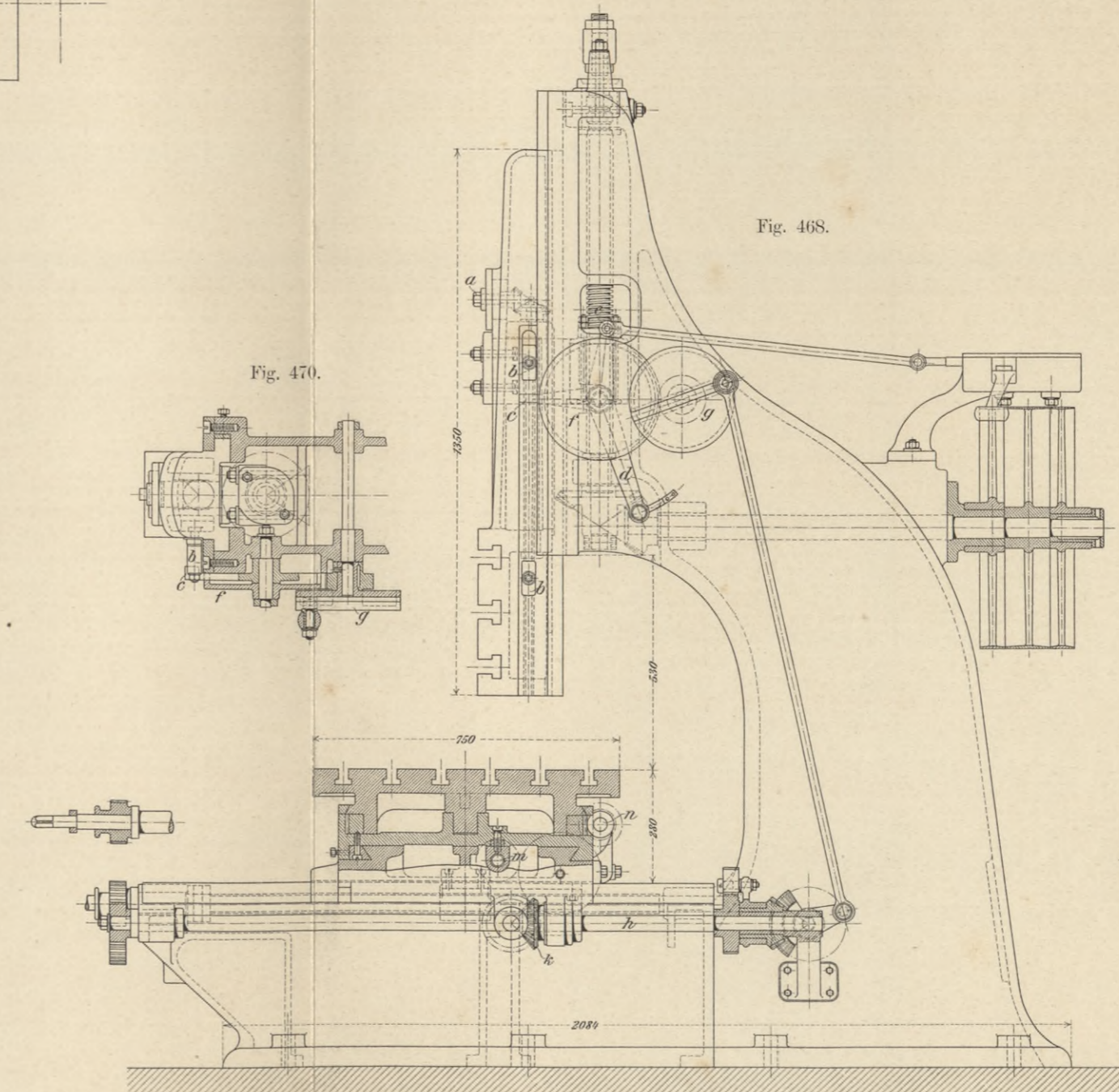
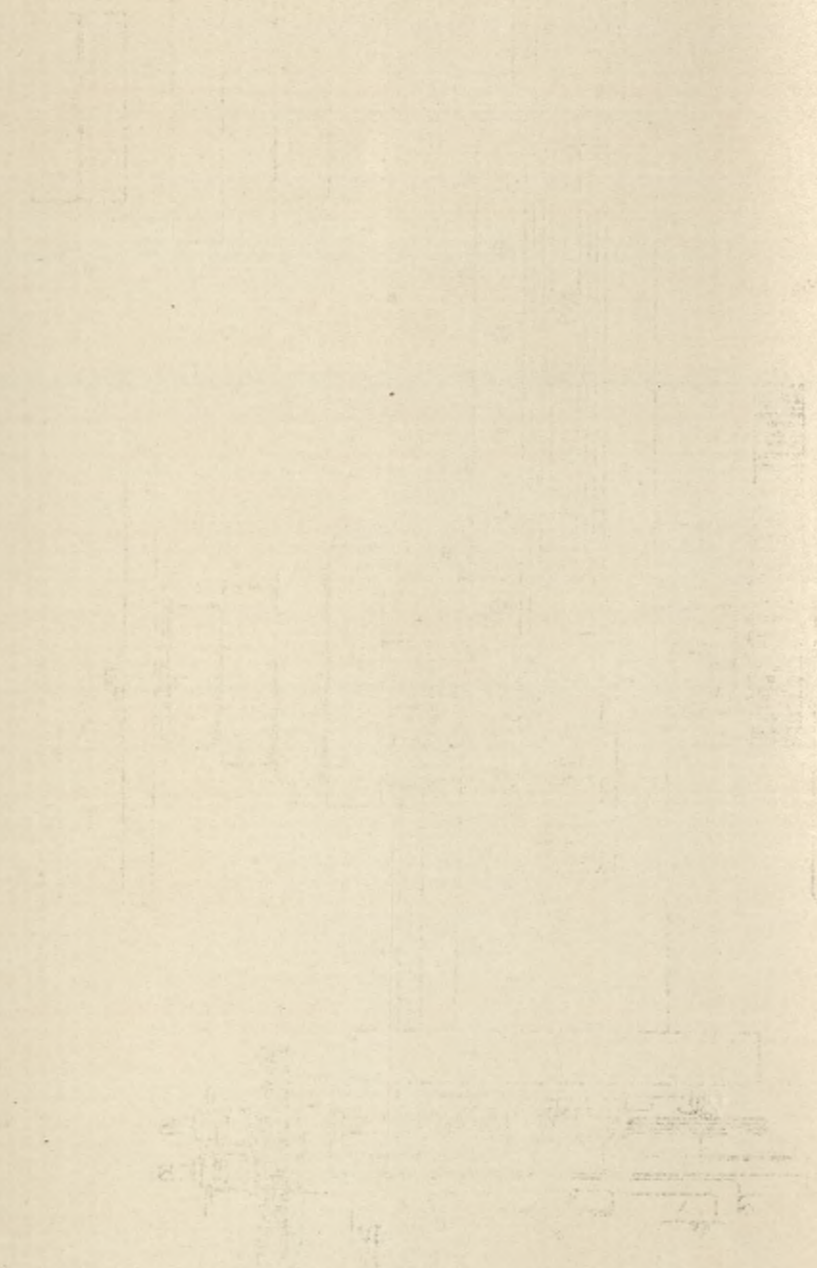

Fig. 468 bis 470.
Stossmaschine von Droop & Rein in Bielefeld.
1/15 wahrer Grösse.





BIBLIOTEKA
KRAKÓW
Politechniczna

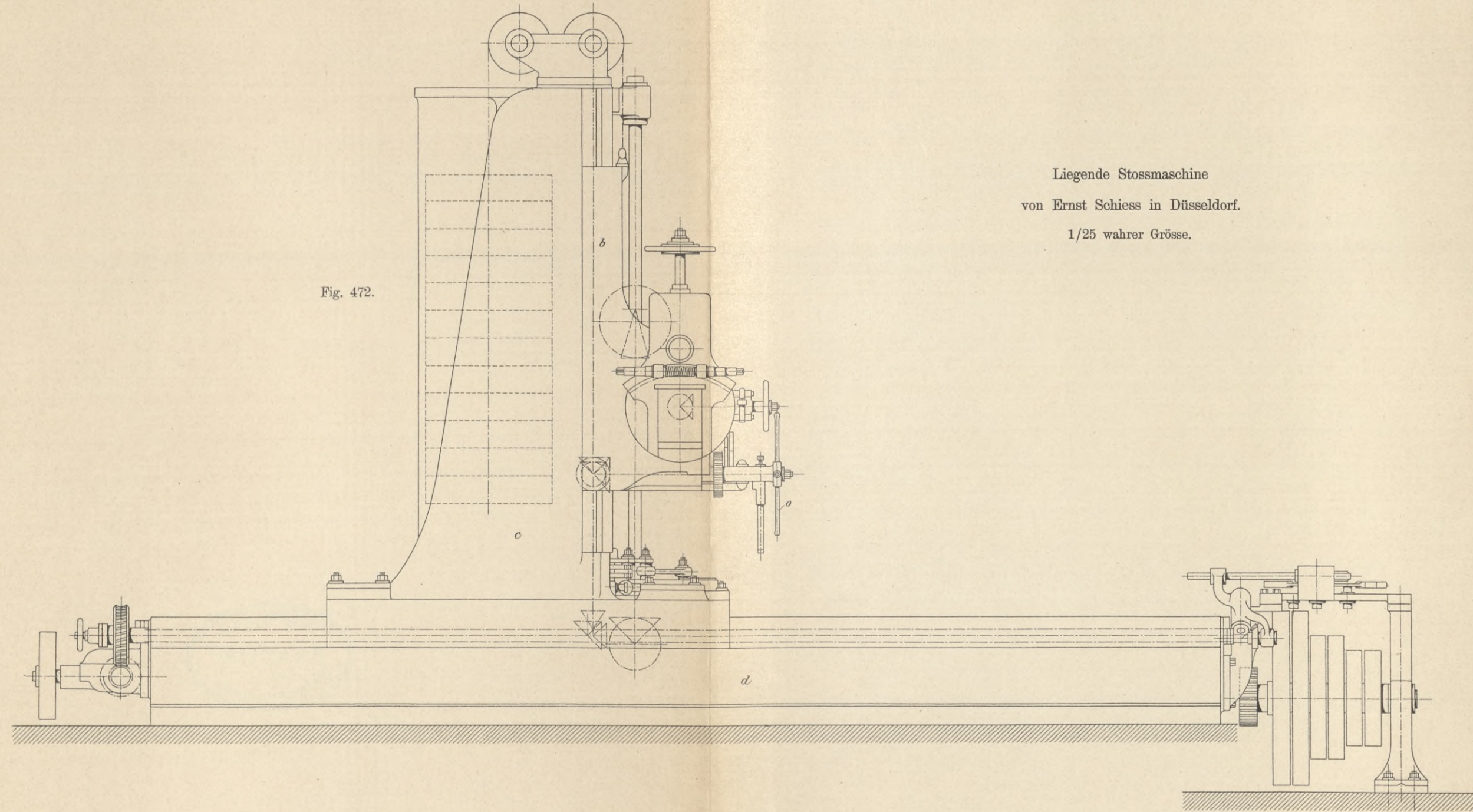

Fig. 472.

Liegende Stossmaschine
von Ernst Schiess in Düsseldorf.
1/25 wahrer Grösse.

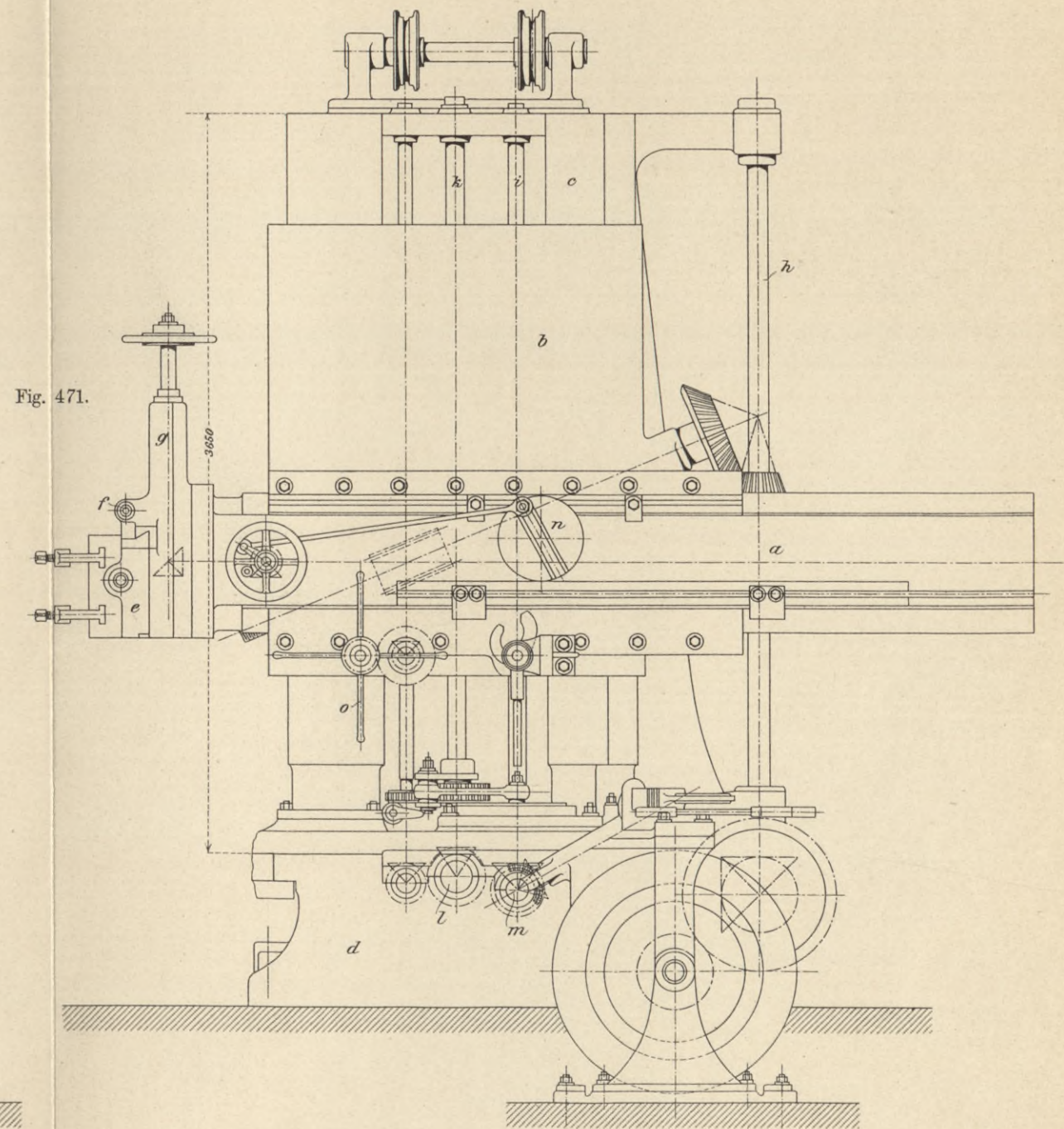
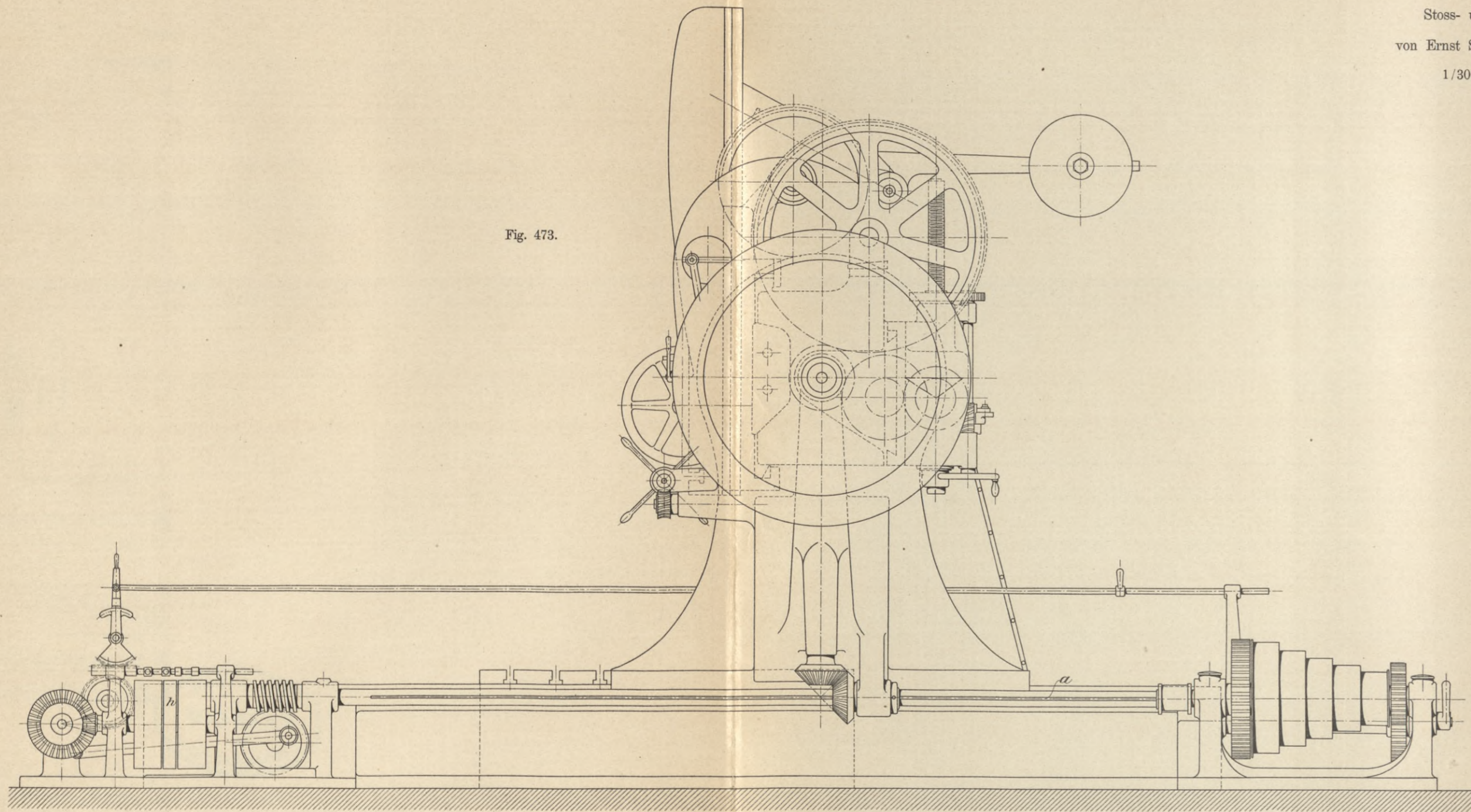
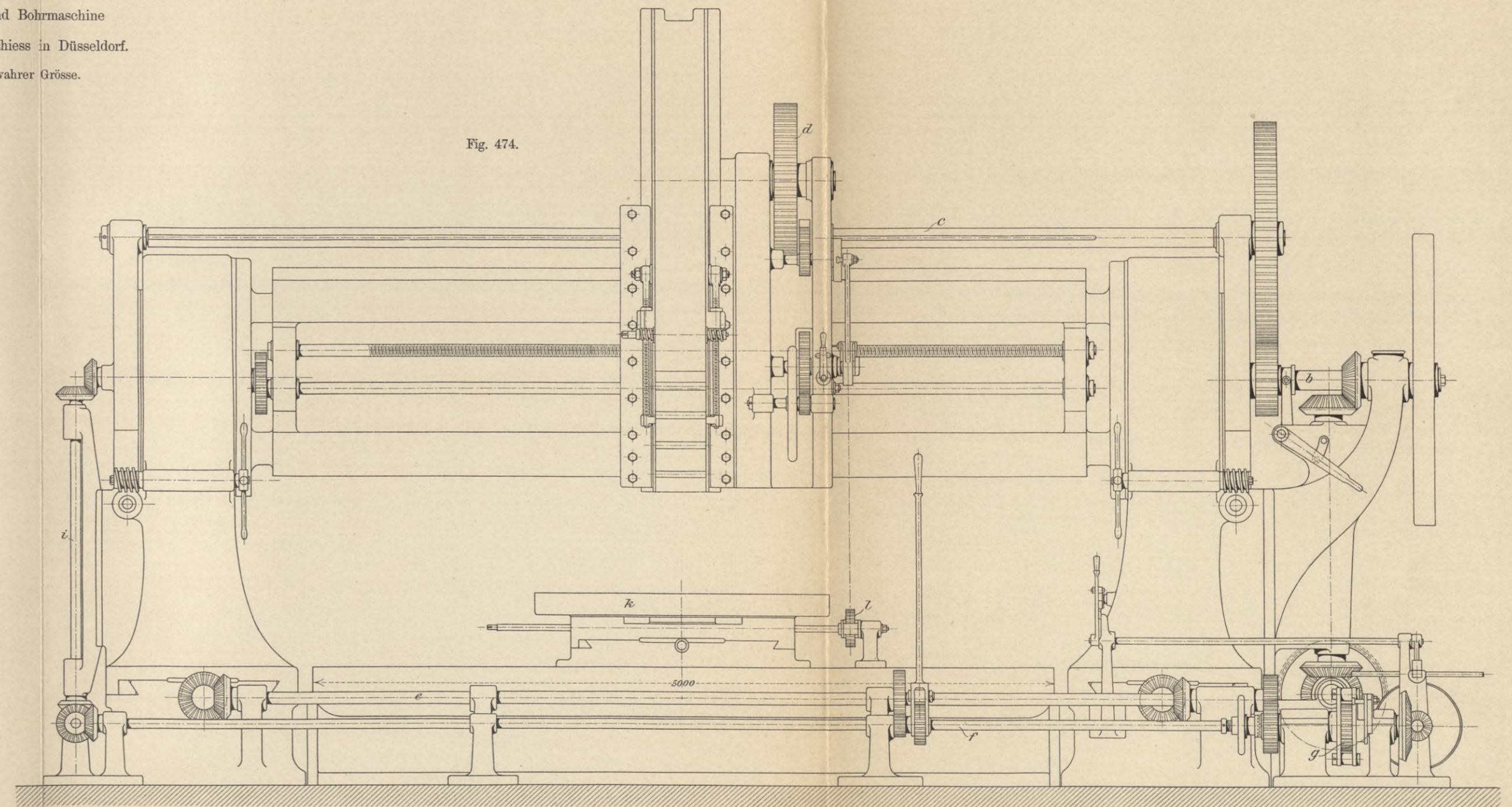

Fig. 471.





Stoss- und Bohrmaschine
 von Ernst Schiess in Düsseldorf.
 1/30 wahrer Grösse.





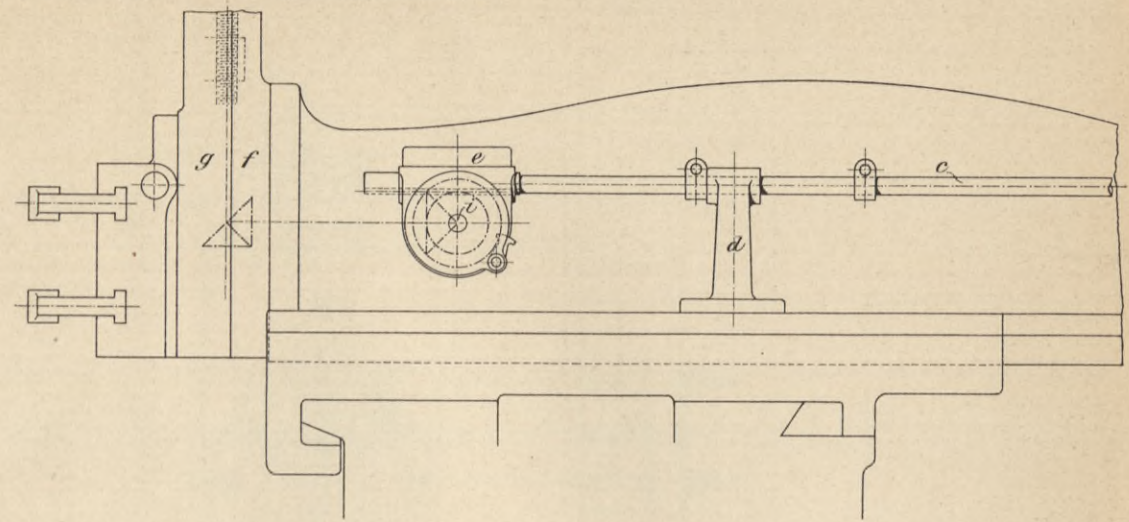
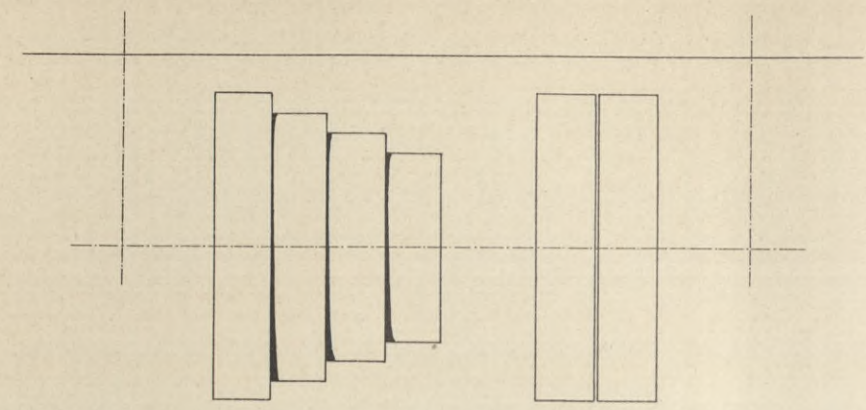

Fig. 480.



Doppelte Feilmaschine
 von Ernst Schiess in Düsseldorf.
 1/20 wahrer Grösse.

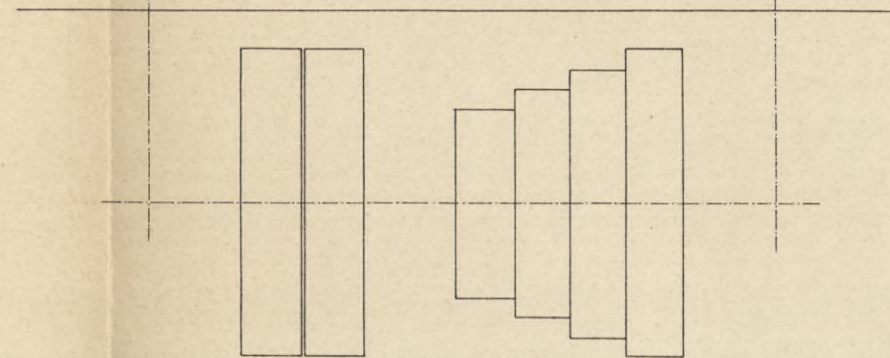

Fig. 478.

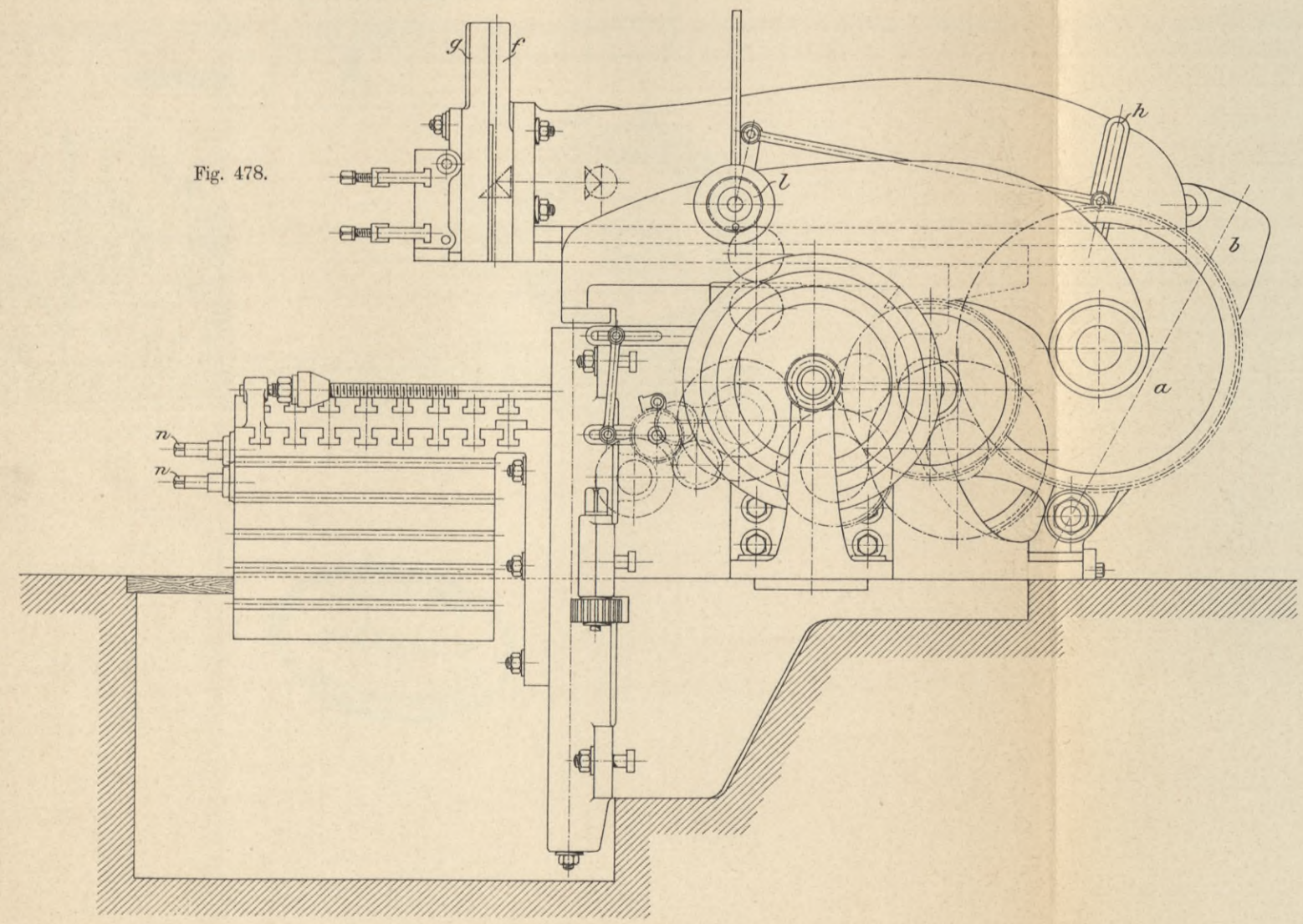
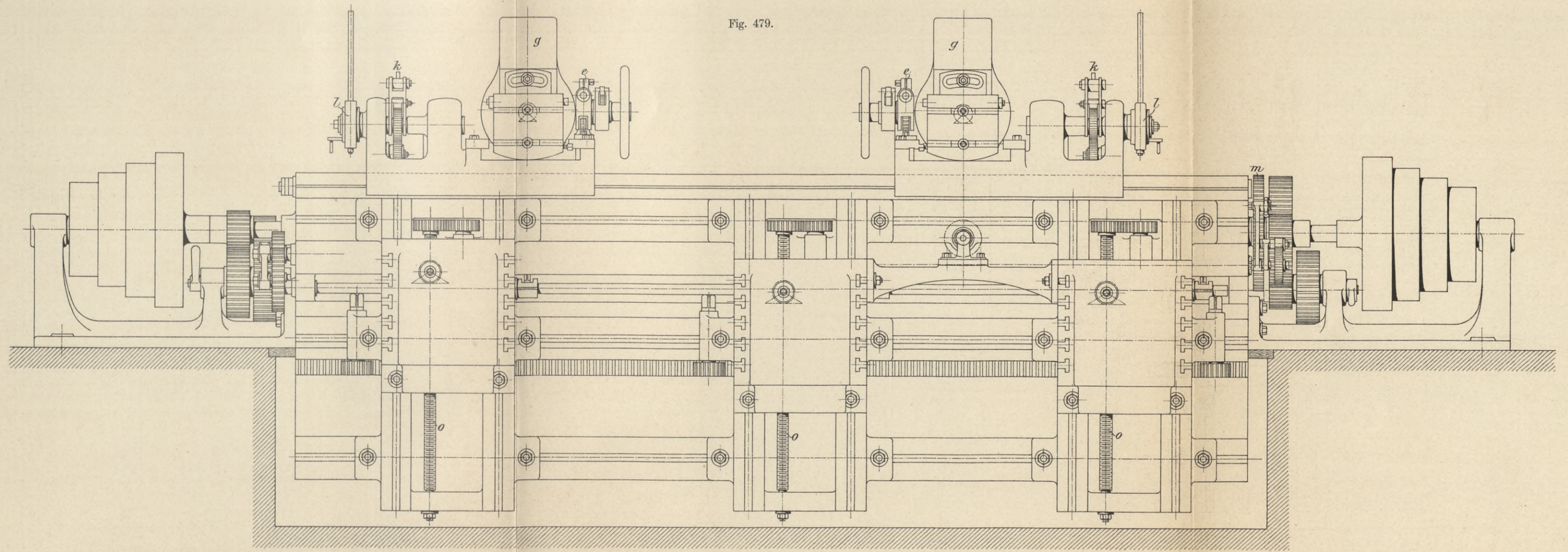

Fig. 479.





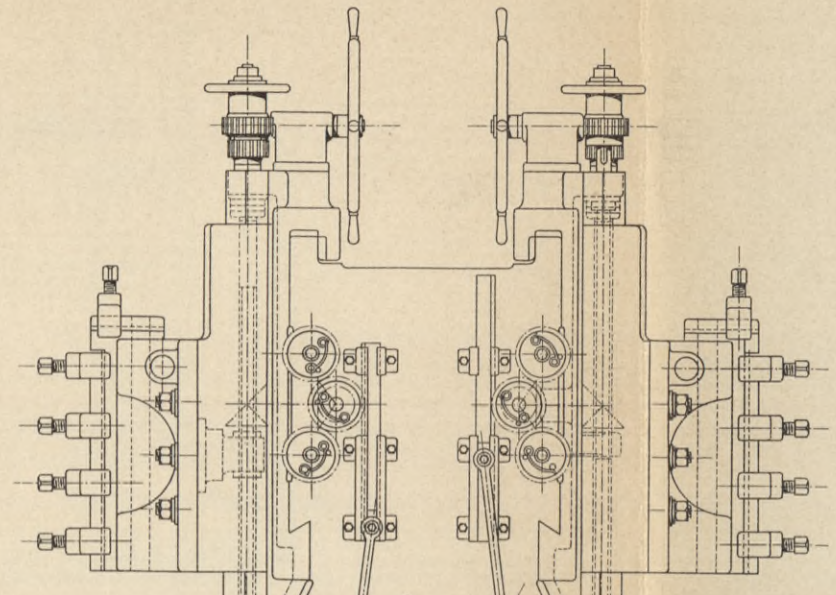
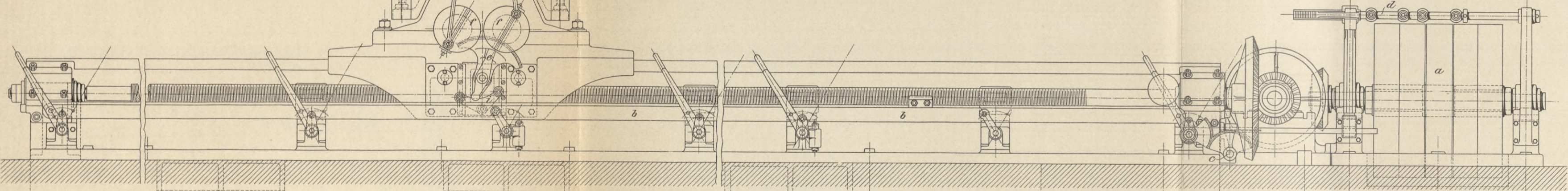

Fig. 485.

Grubenhobelmaschine
 von Ernst Schiess in Düsseldorf.
 1/30 wahrer Grösse.



15500 Bettlänge

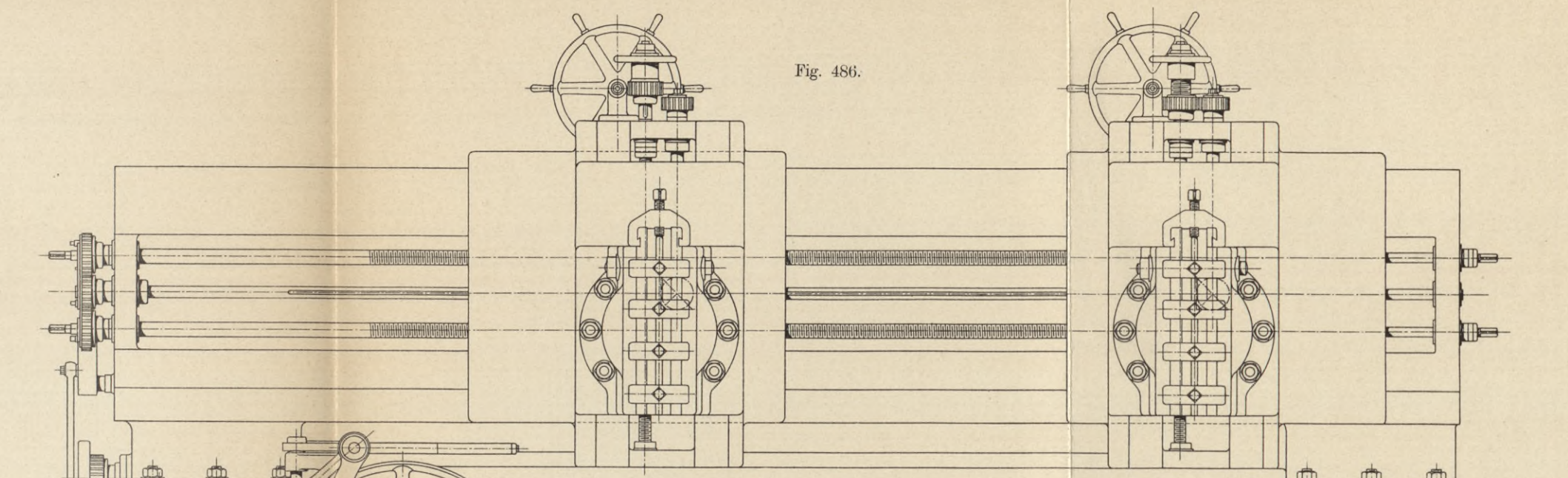
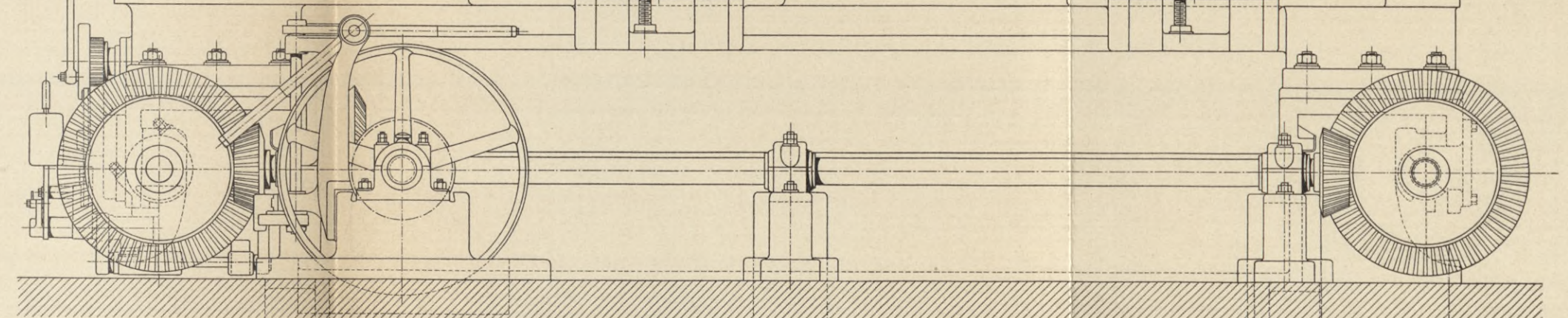

Fig. 486.



BIBLIOTEKA
KRAKÓW
Politechniczna

Fig. 487.

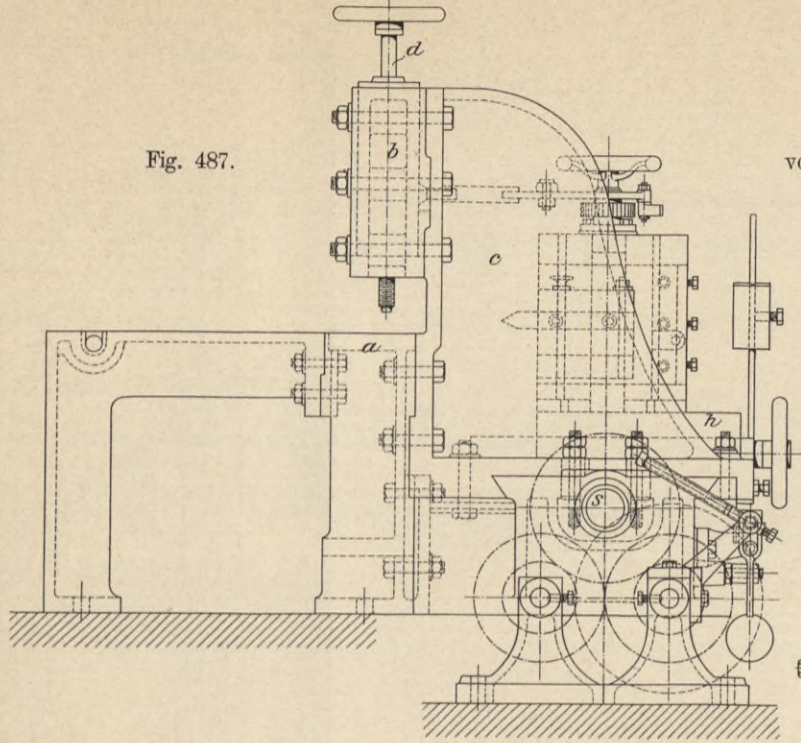

Fig. 487 u. 488:
Blechkantenhobelmaschine
von L. W. Breuer, Schumacher & Co.
in Kalk bei Köln.
1/20 w. Gr.

Fig. 488.

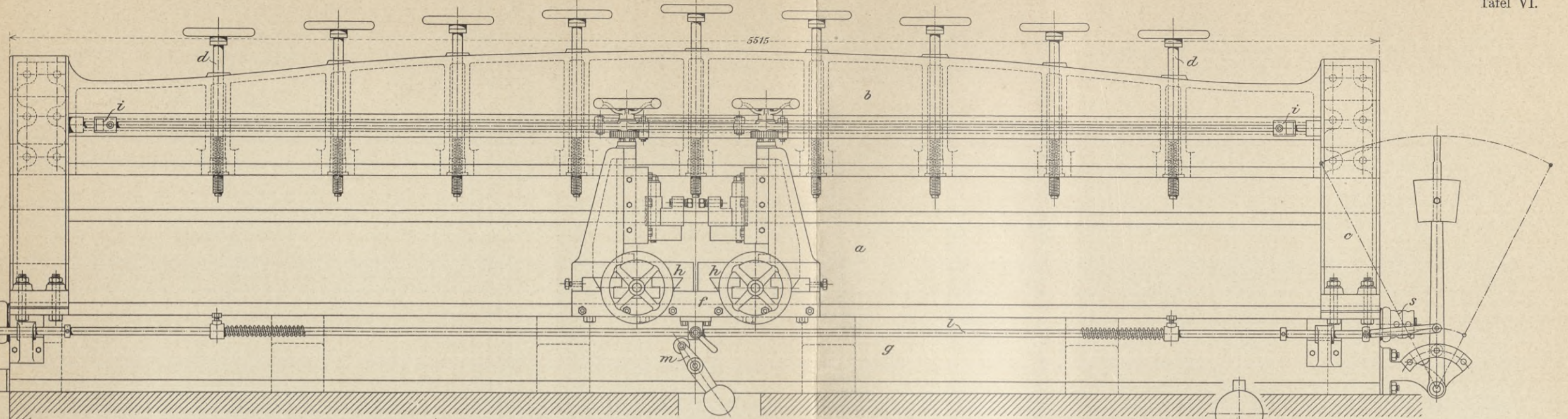
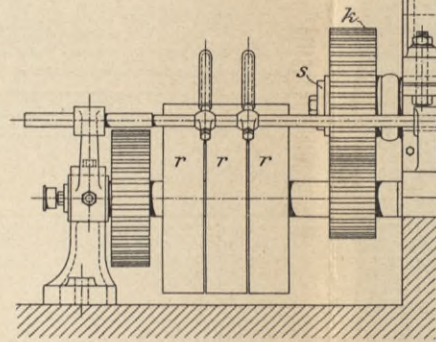

Fig. 497 u. 498: Besäummaschine von Ernst Schiess in Düsseldorf. 1/20 wahrer Grösse.

Fig. 497.

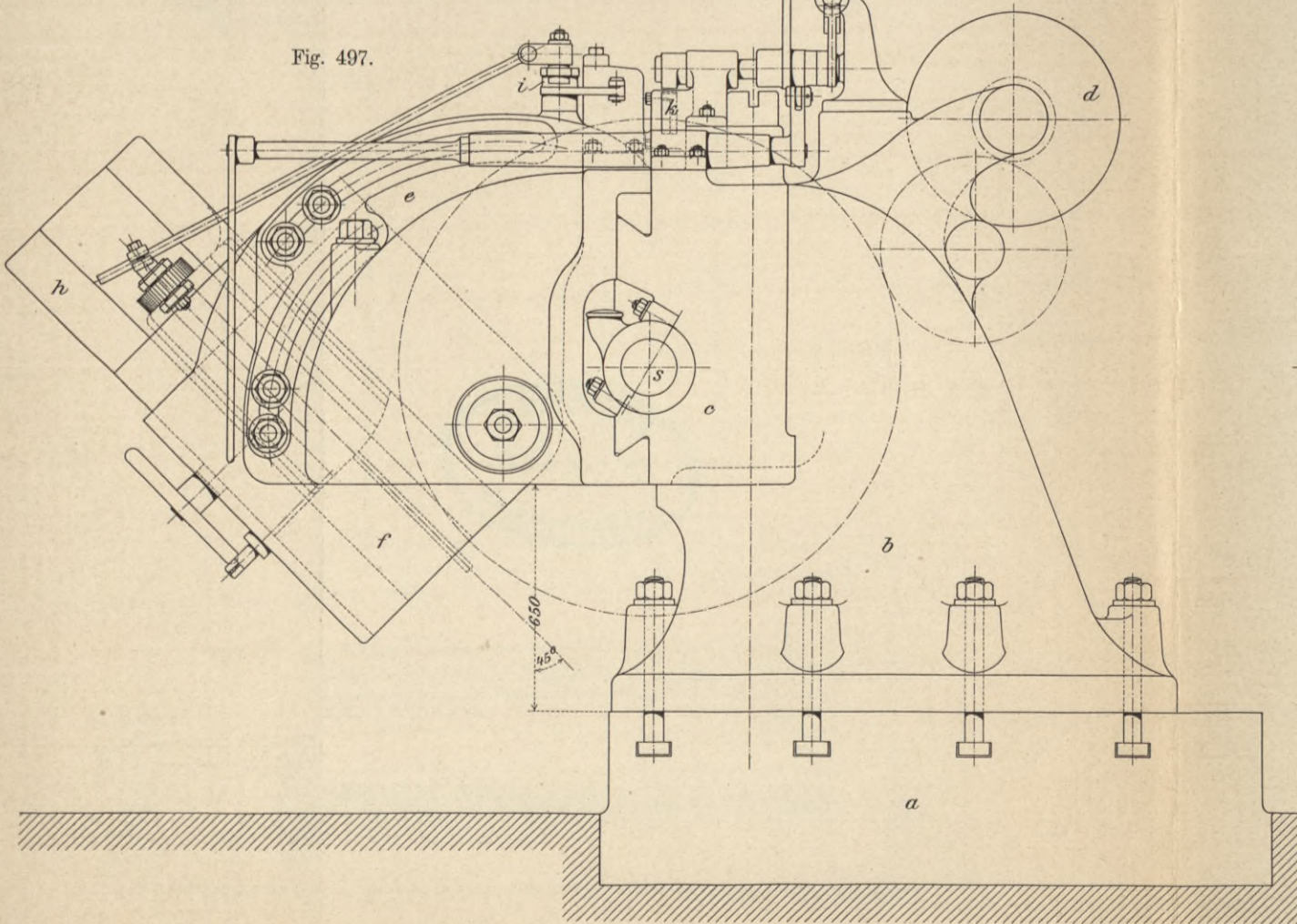

Fig. 498.

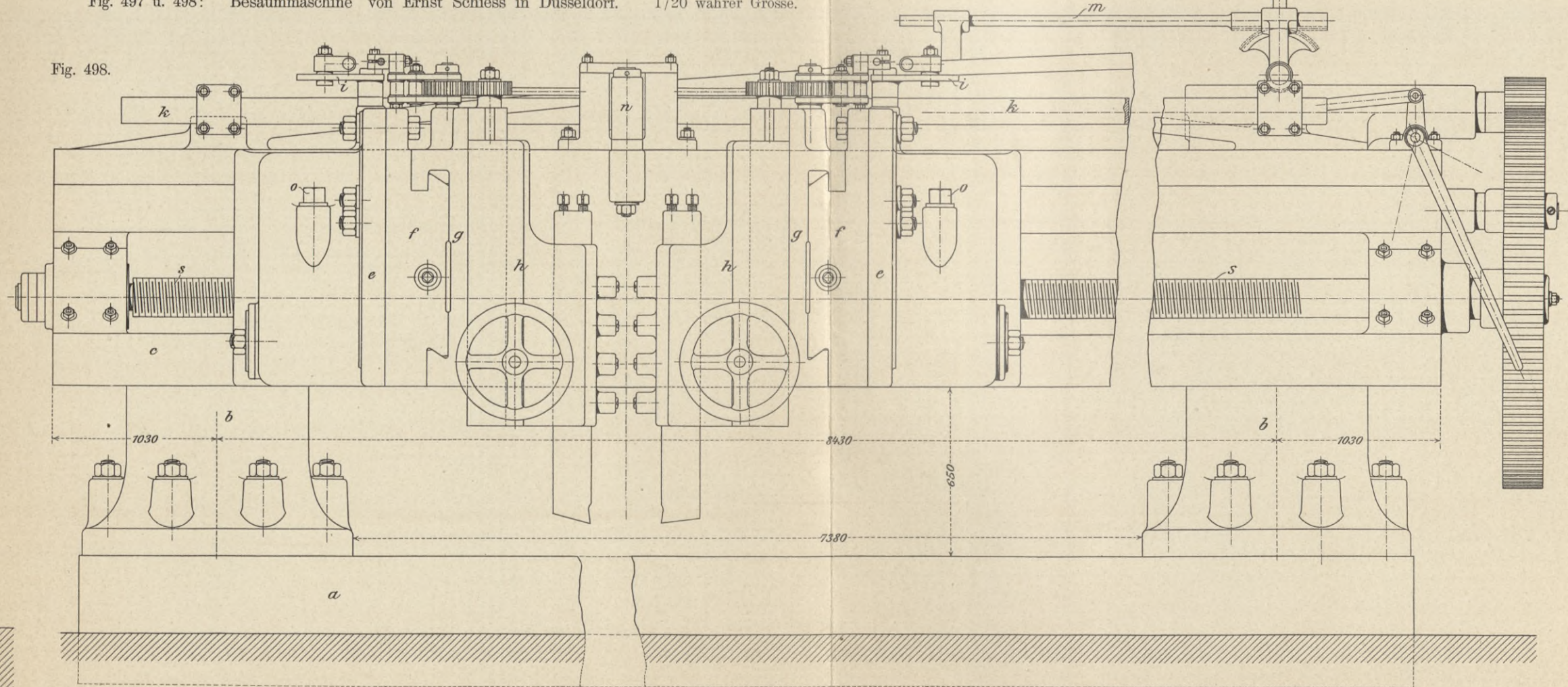
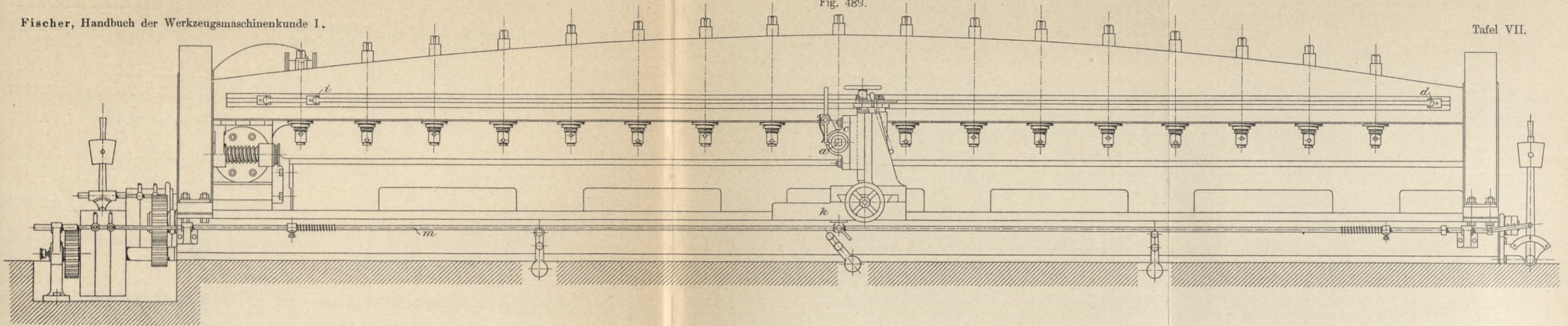



Fig. 489.



Blechkantenhobelmaschine von L. W. Breuer, Schumacher & Co. in Kalk bei Köln.

1/30 wahrer Grösse

Fig. 490.

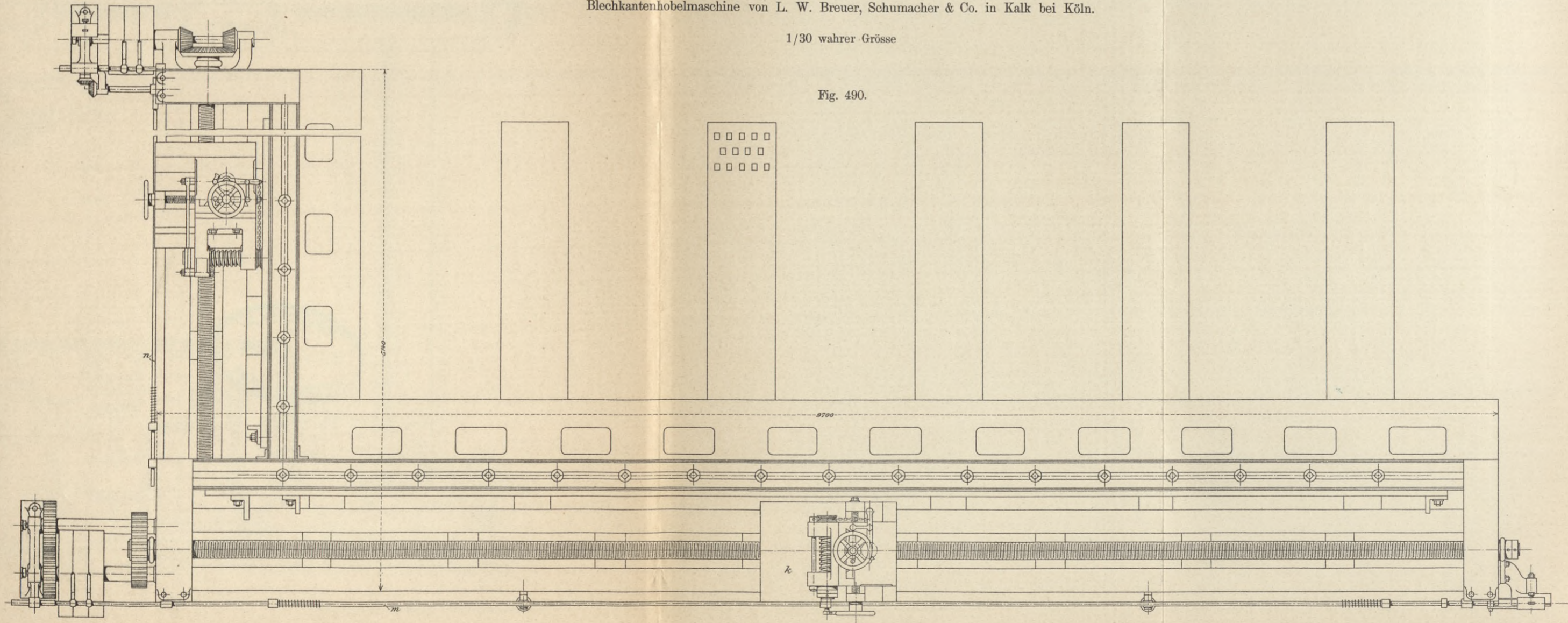



Tischhobelmaschine
von Droop & Rein in Bielefeld.
1/15 wahrer Grösse.

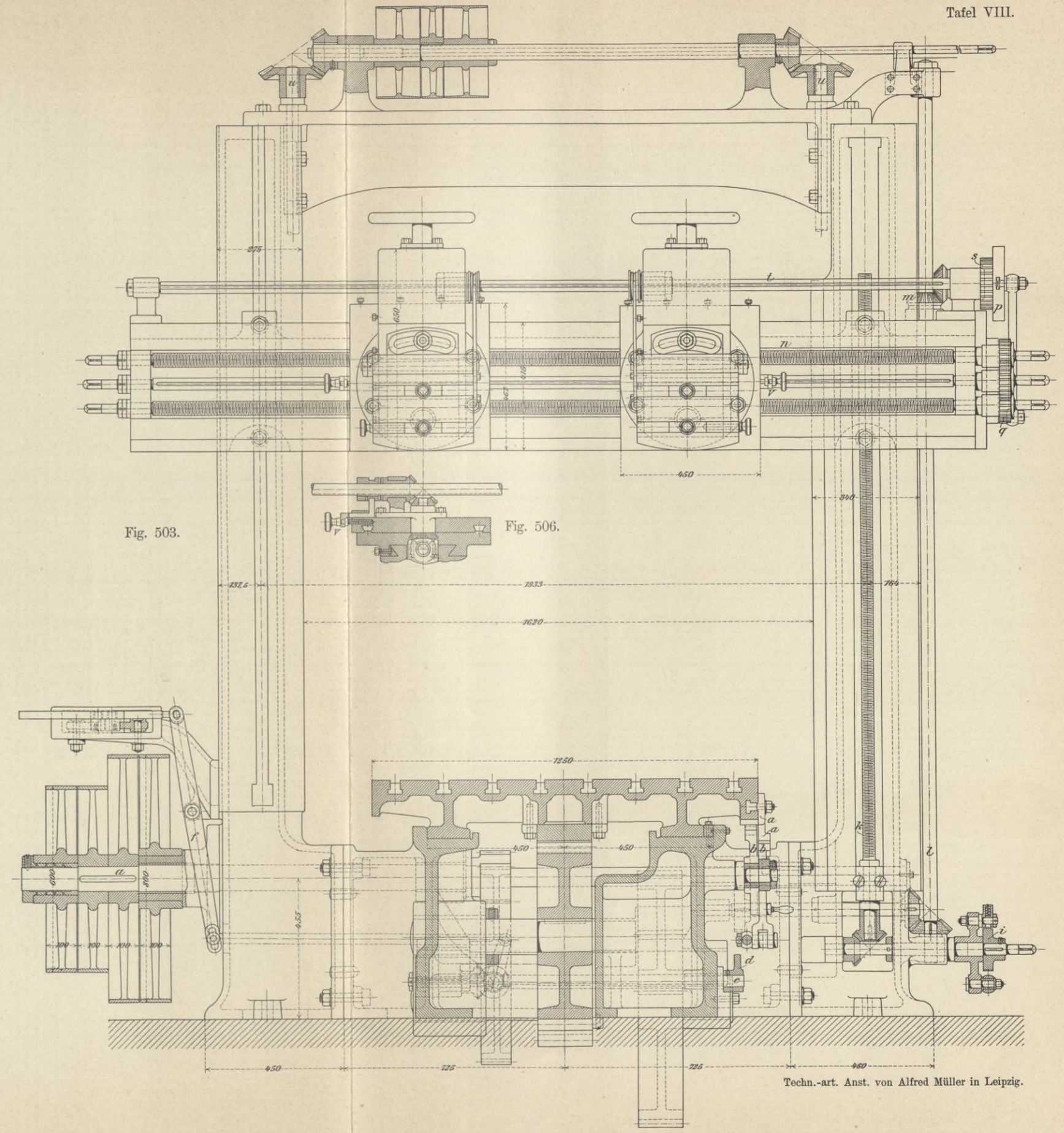
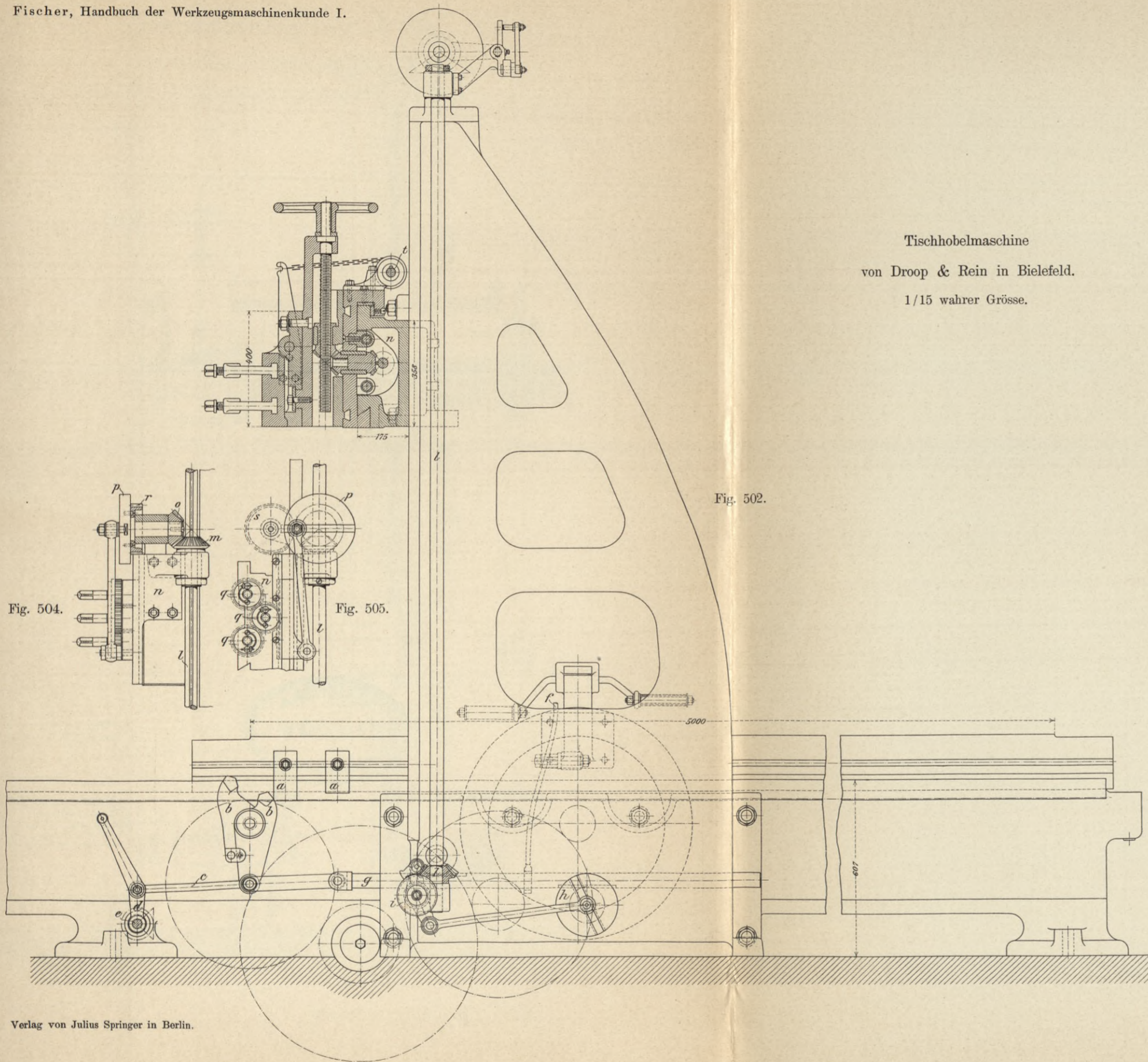
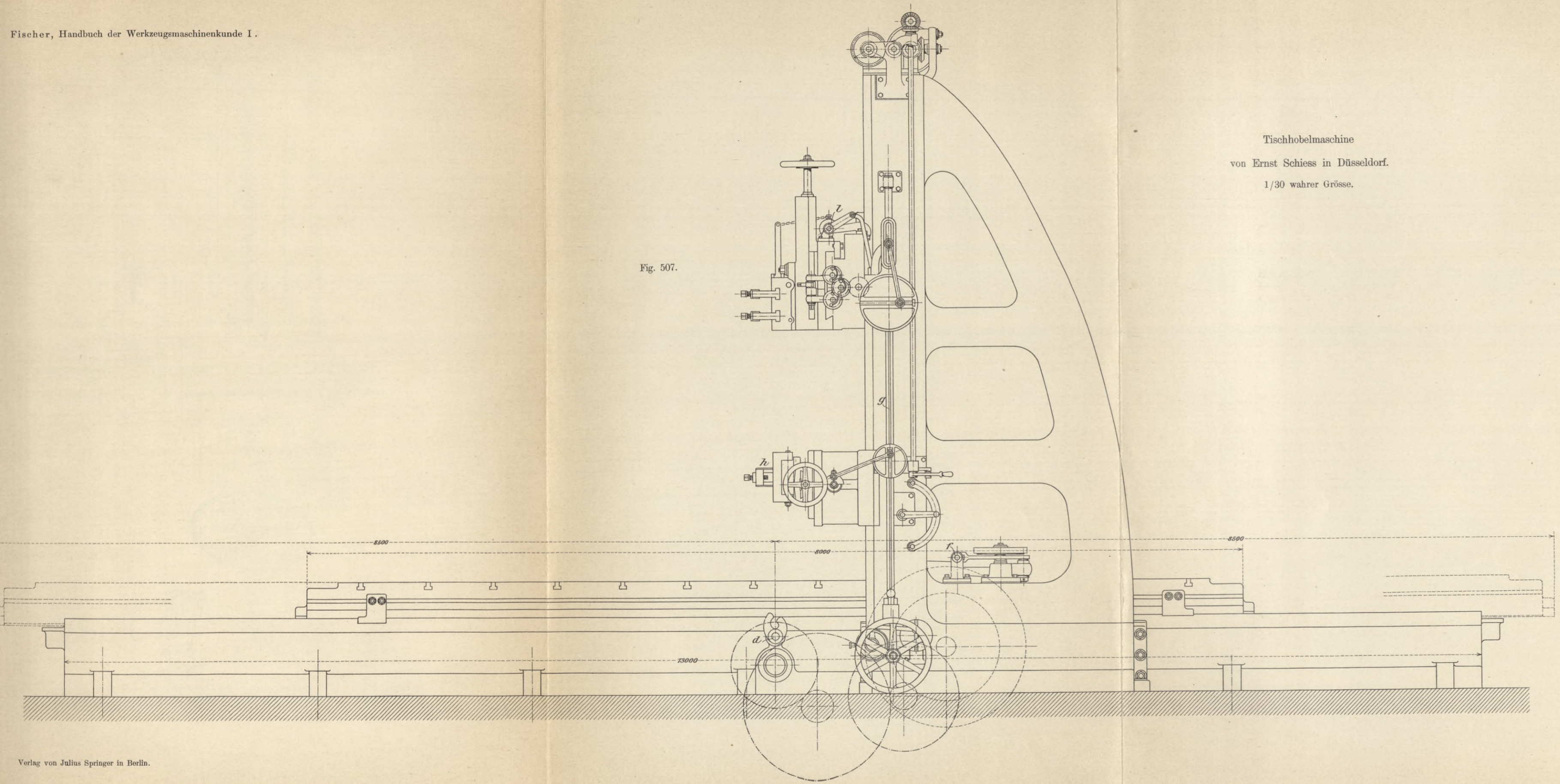



Fig. 507.



Tischhobelmaschine
 von Ernst Schiess in Düsseldorf.
 1/30 wahrer Grösse.

Fig. 508.

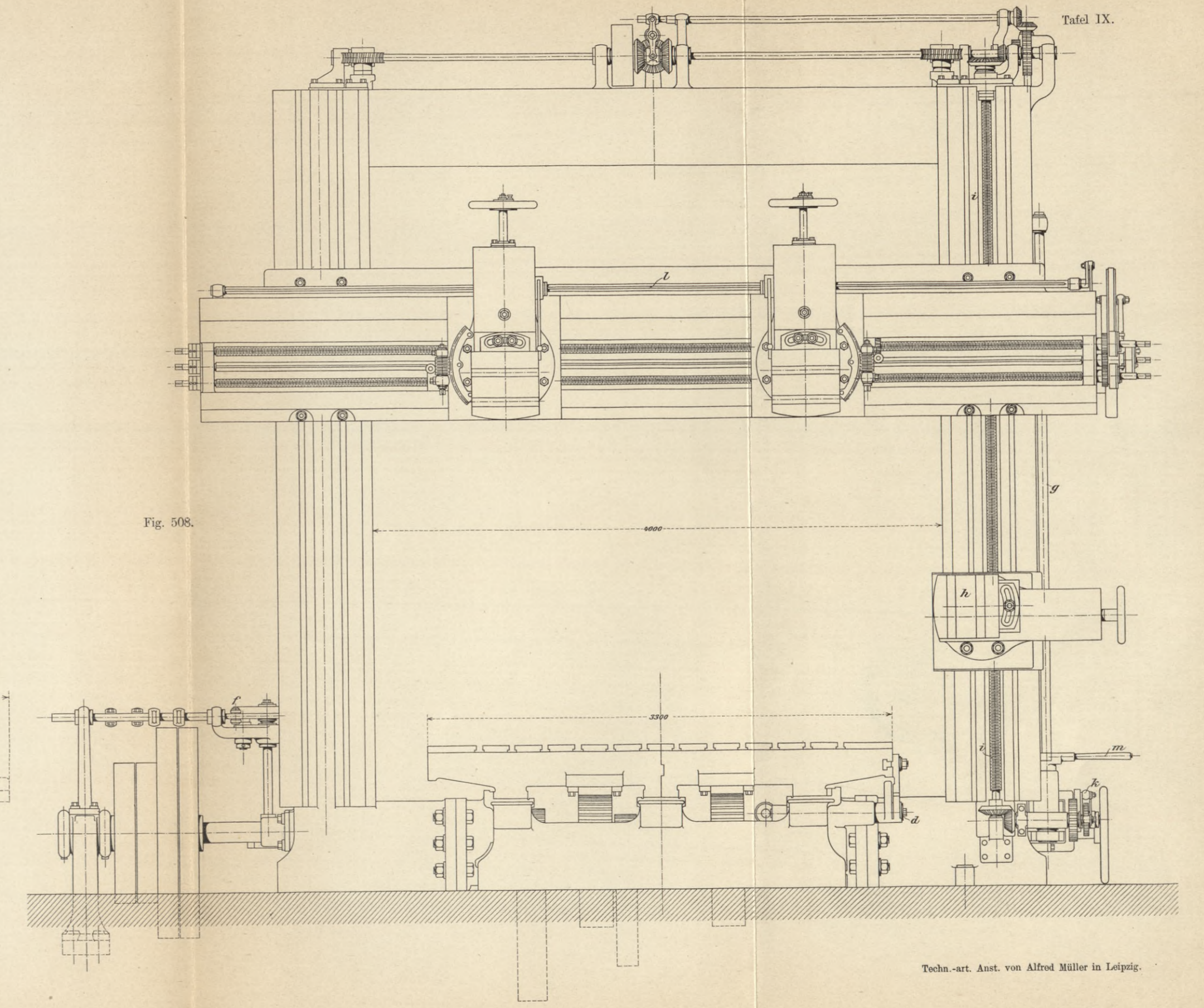
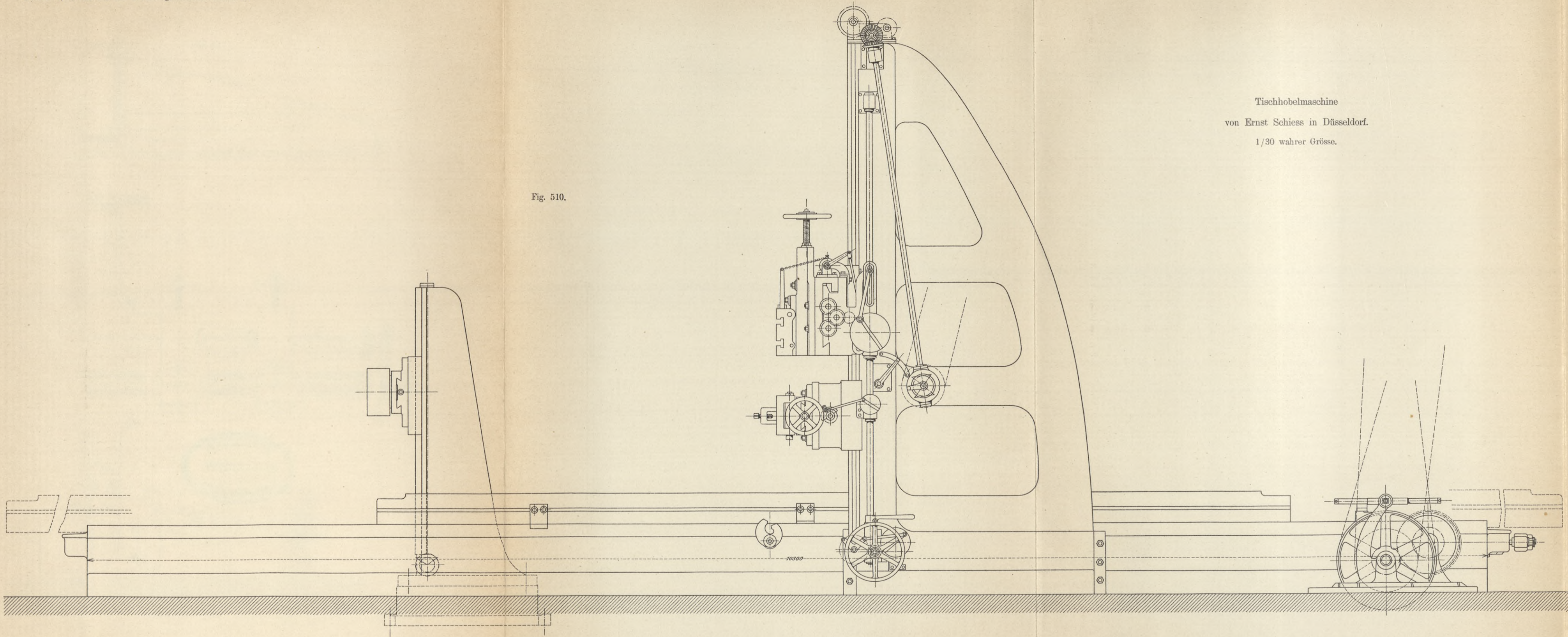
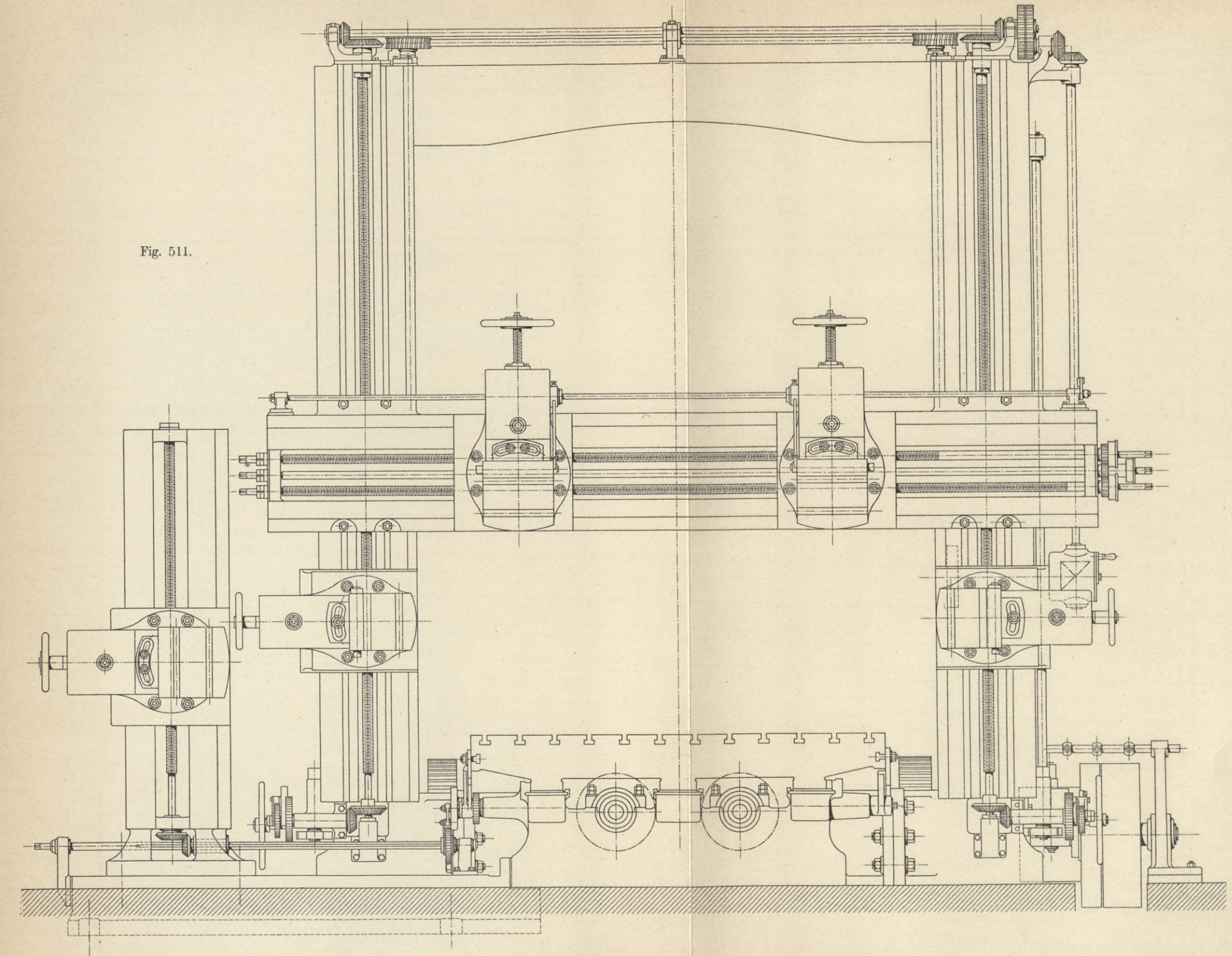

Fig. 510.



Tischhobelmaschine
 von Ernst Schiess in Düsseldorf.
 1/30 wahrer Grösse.

Fig. 511.



Einständer - Hobelmaschine
von Ernst Schiess in Düsseldorf.
1/25 wahrer Grösse.

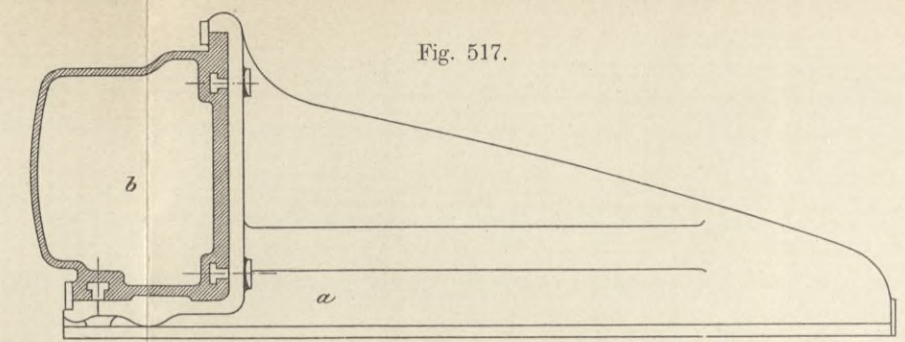
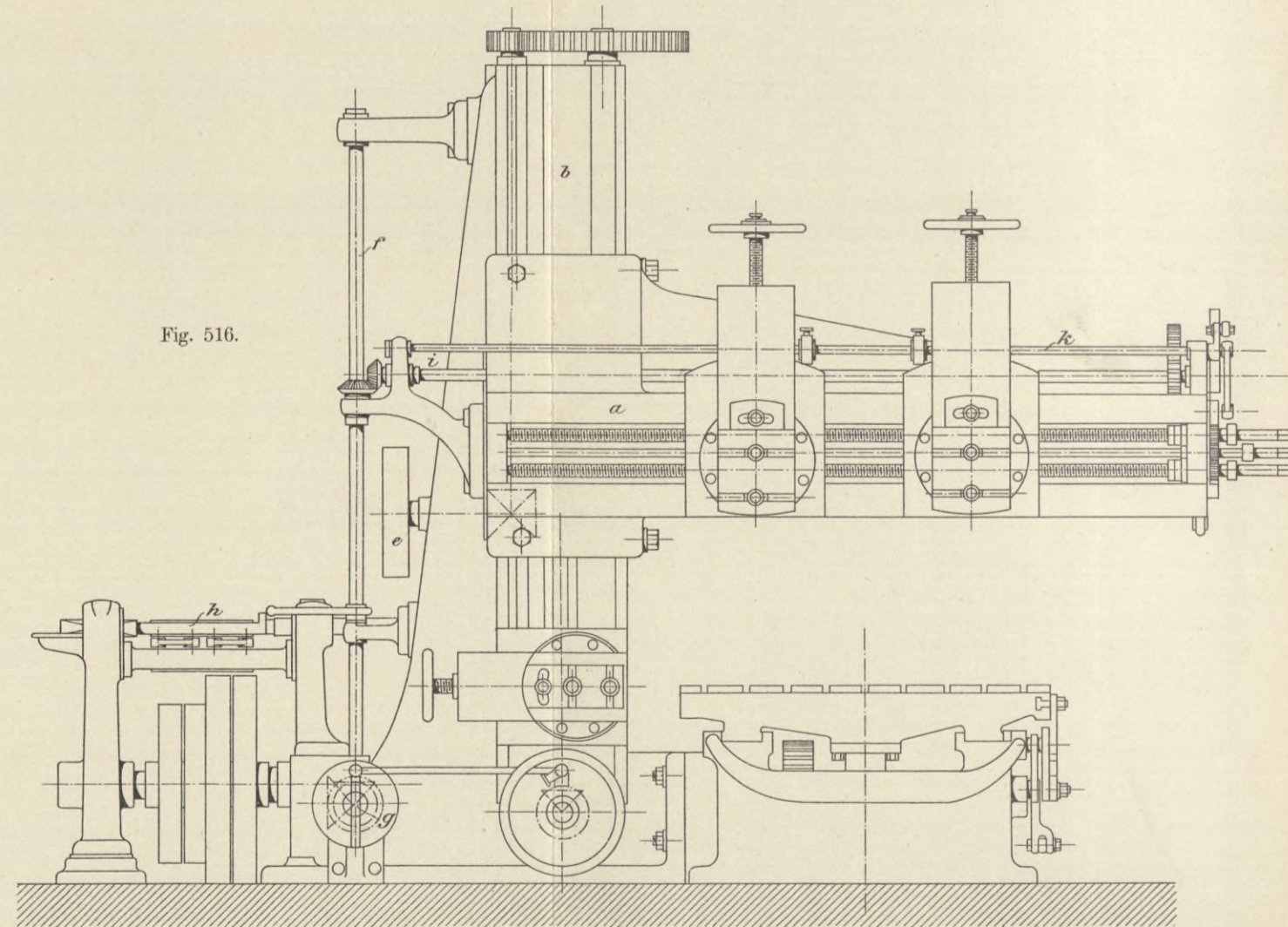
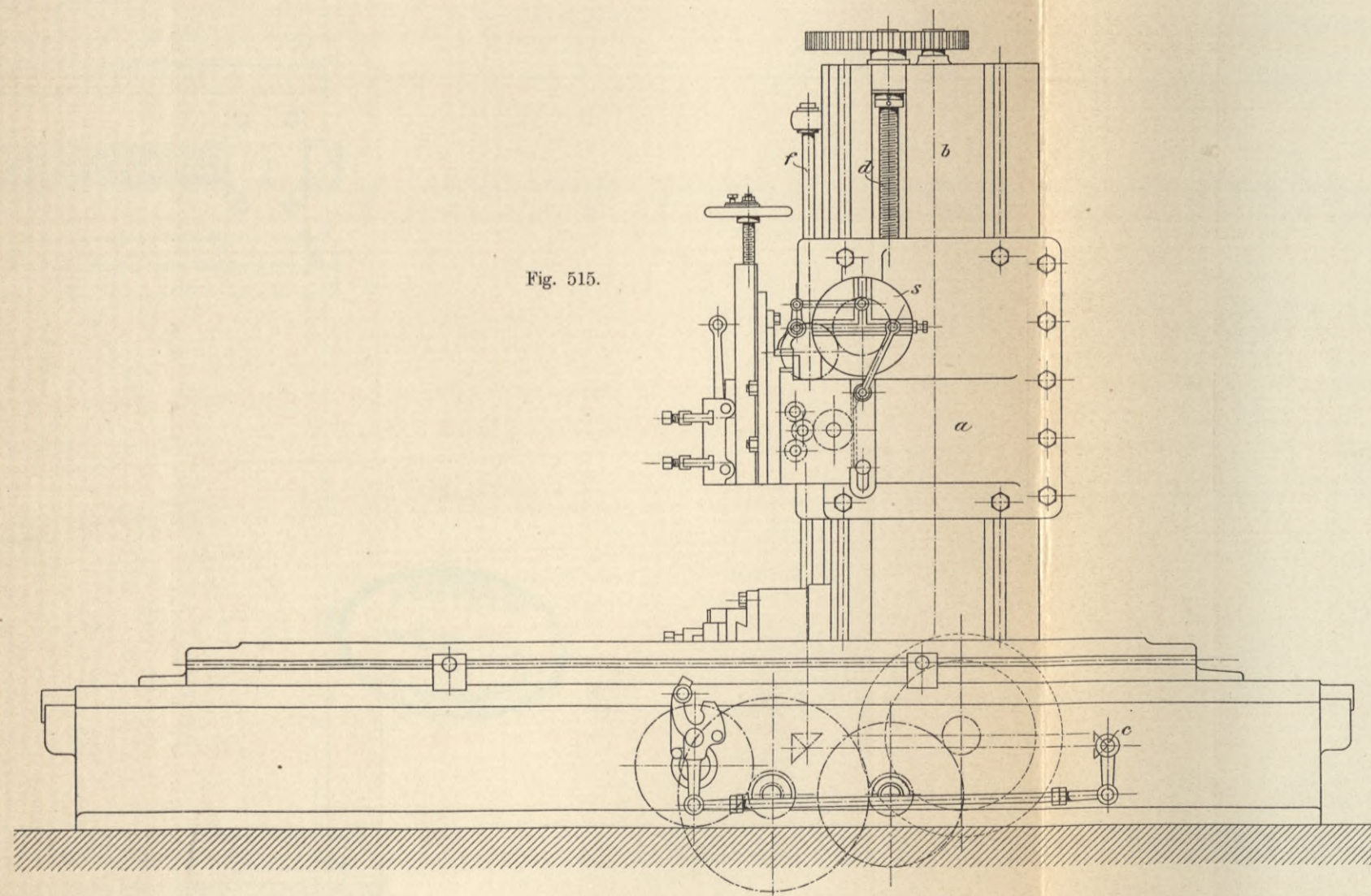





Spitzendrehbank
von H. Wohlenberg in Hannover.
2/25 wahrer Grösse.

Fig. 558.

Fig. 559.

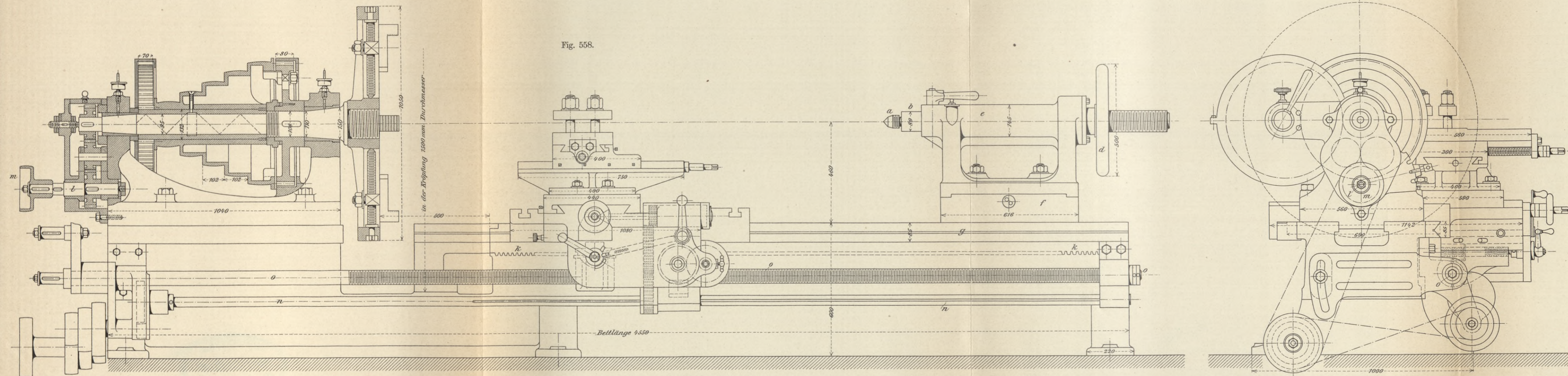



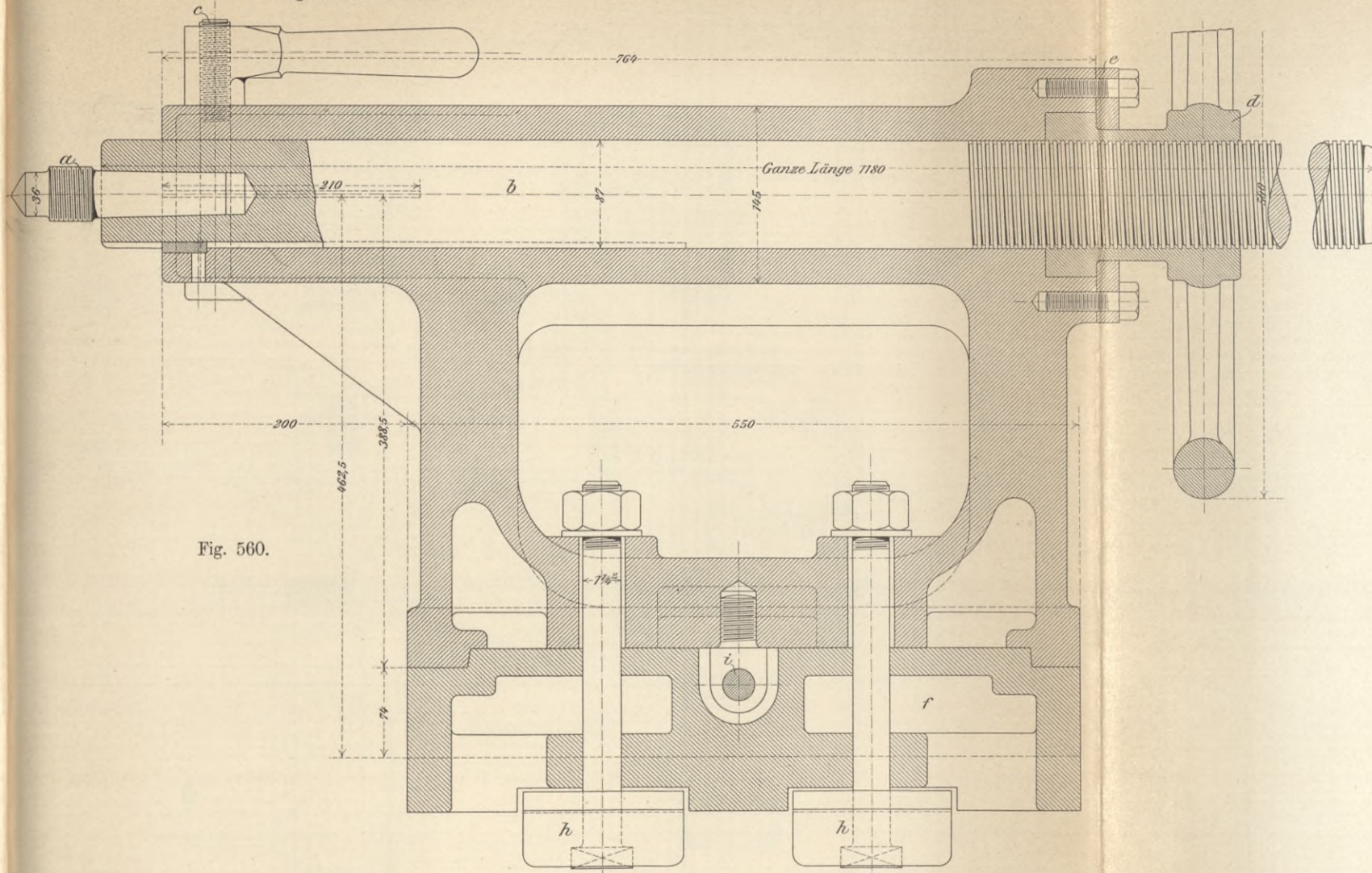

Fig. 560.

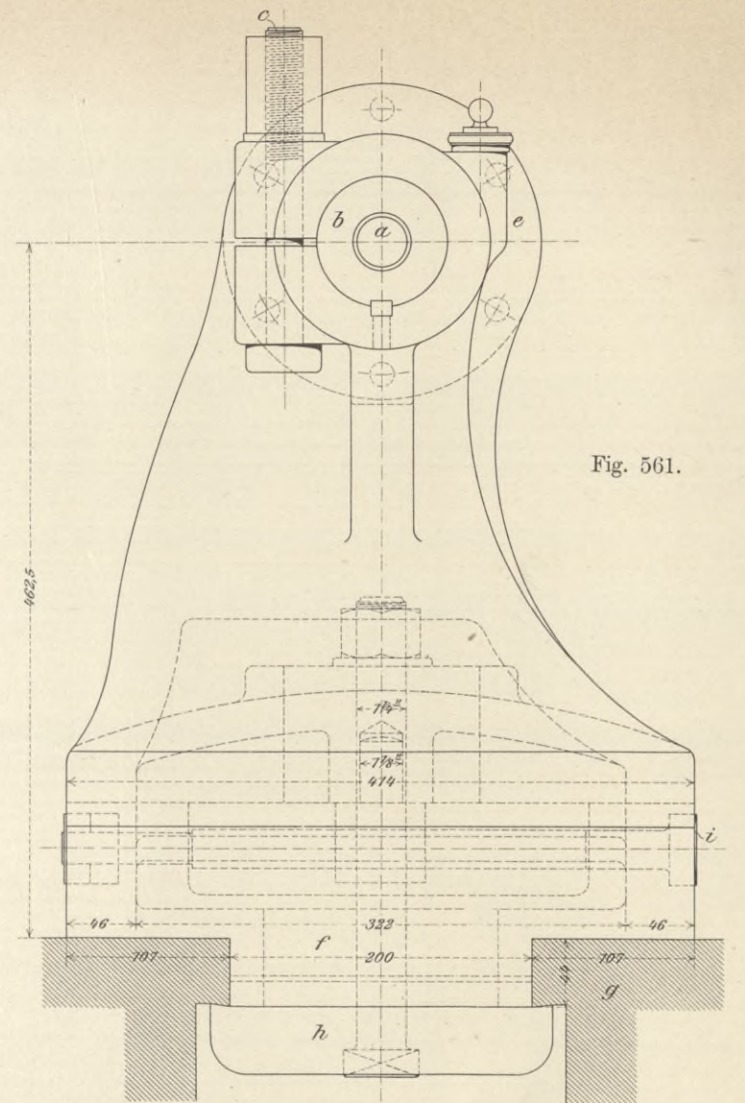

Fig. 561.

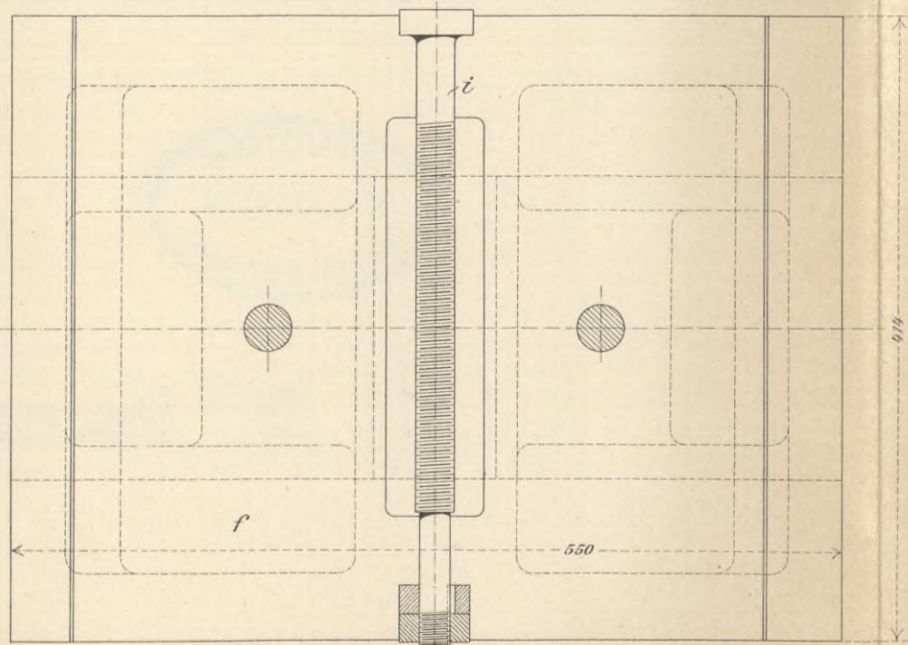

Fig. 563.

1/5 wahrer Grösse.

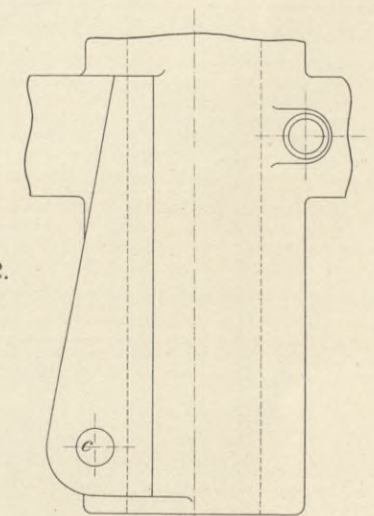

Fig. 562.



Fig. 564.

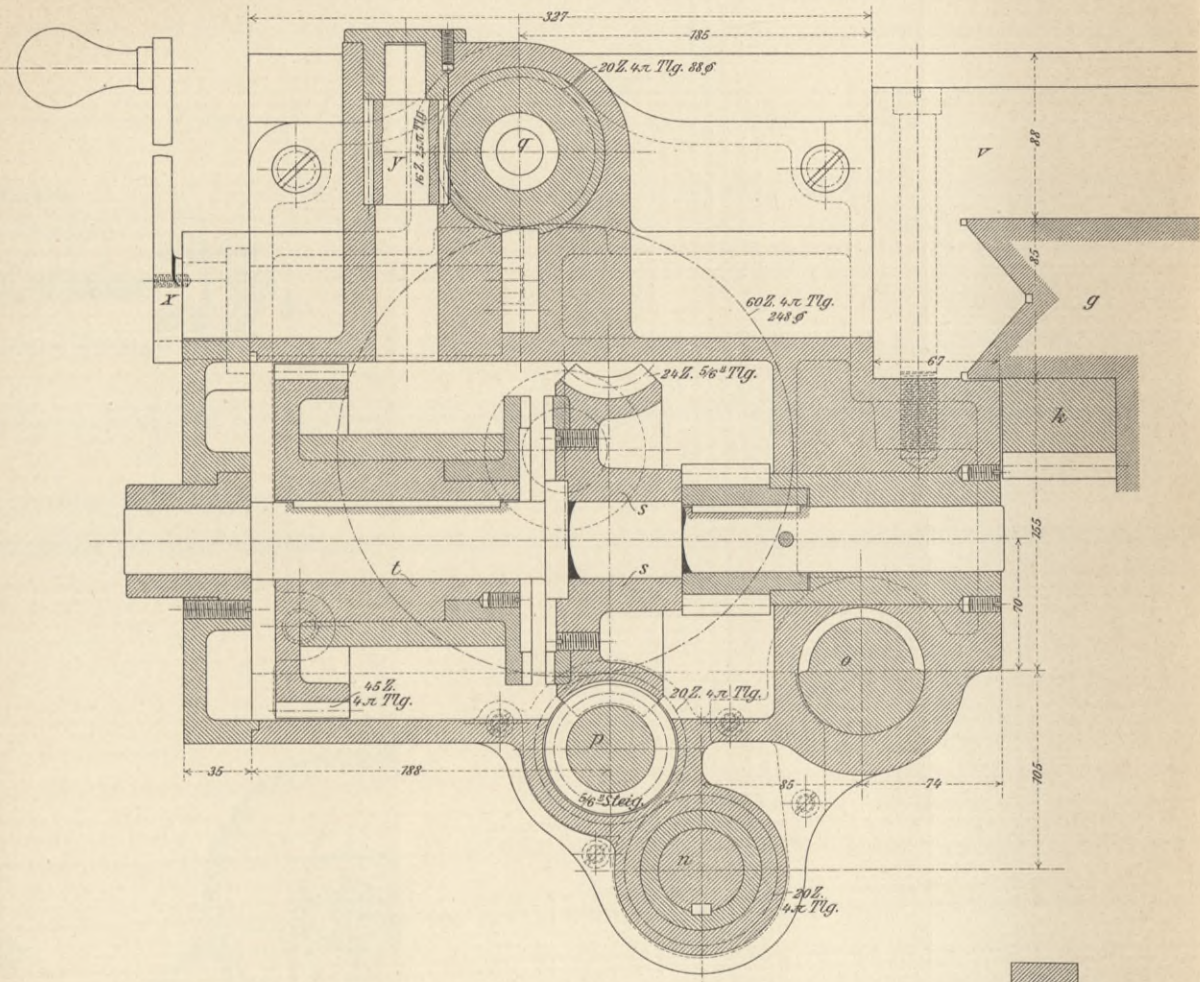

Fig. 565.

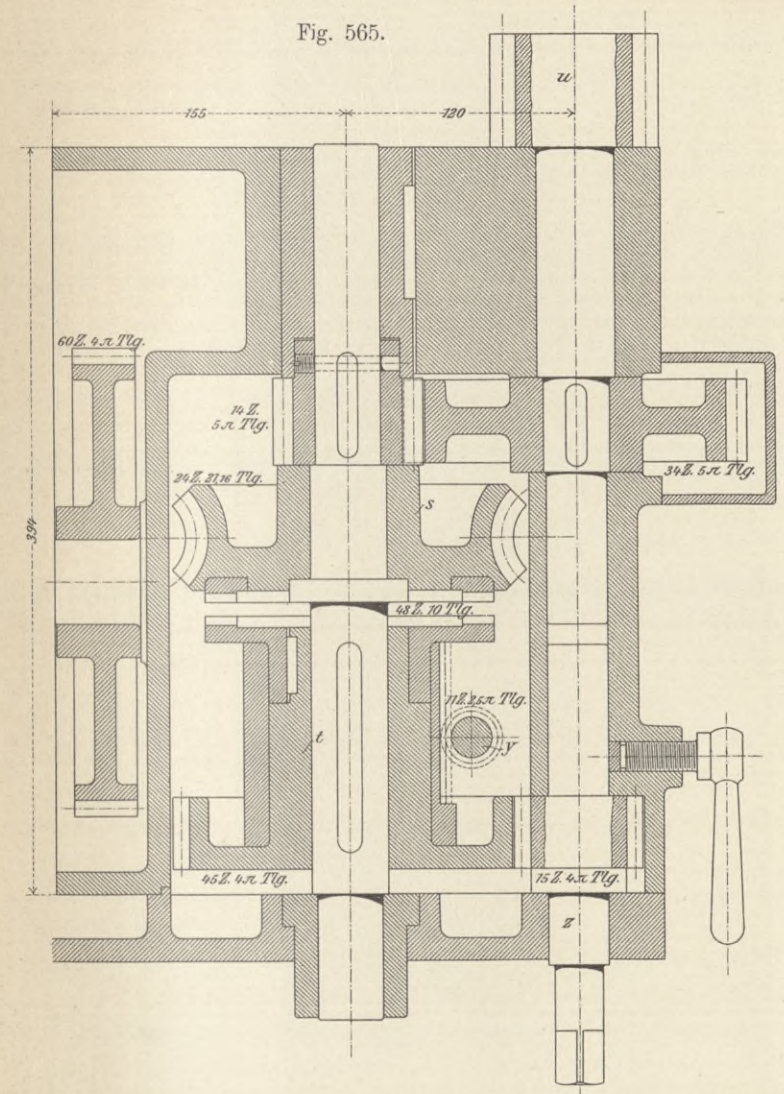

Fig. 566.

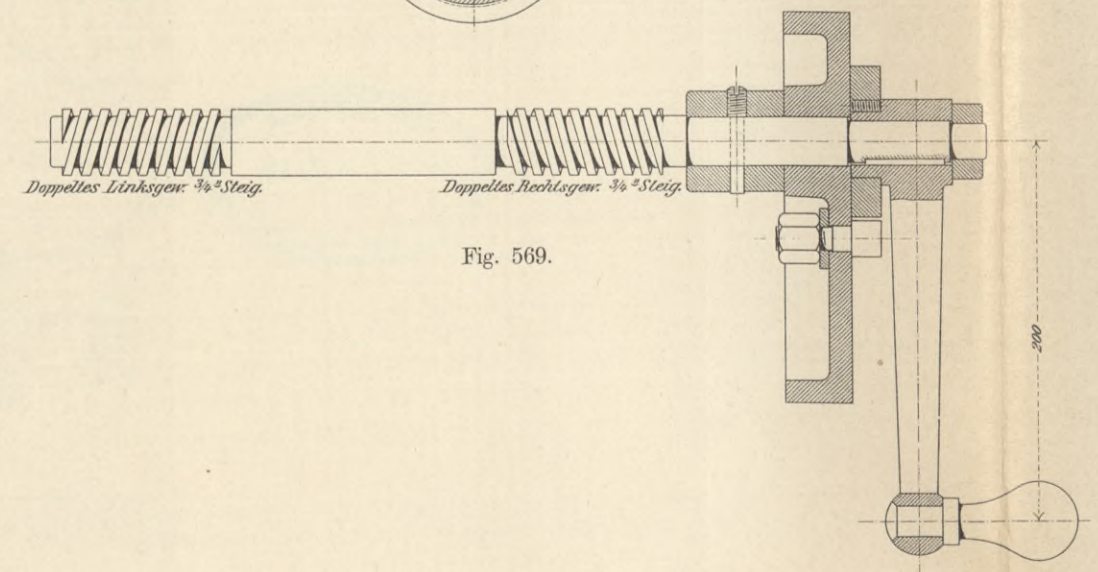
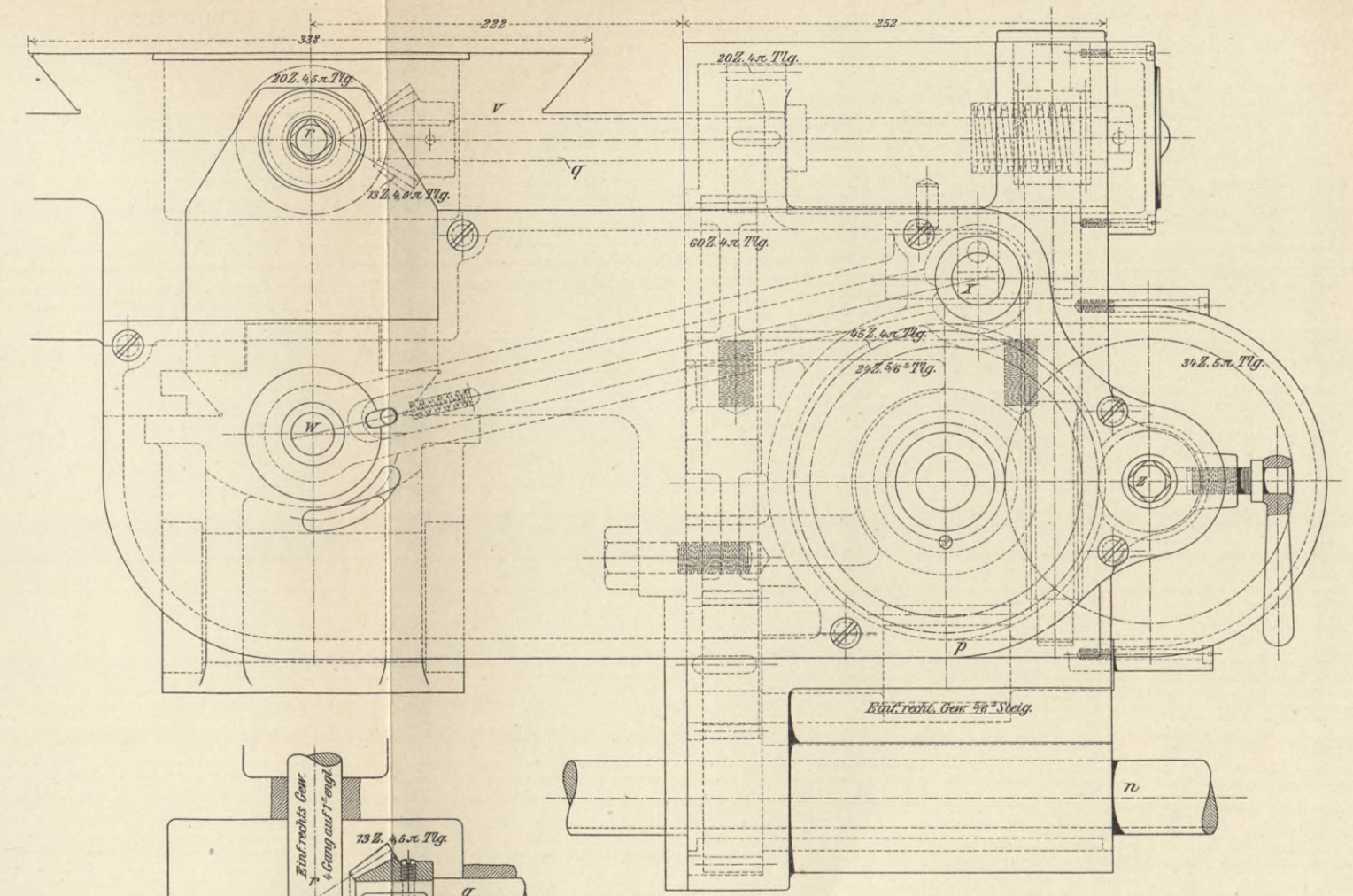

Fig. 569.

1/4 wahrer Grösse.

Fig. 567.

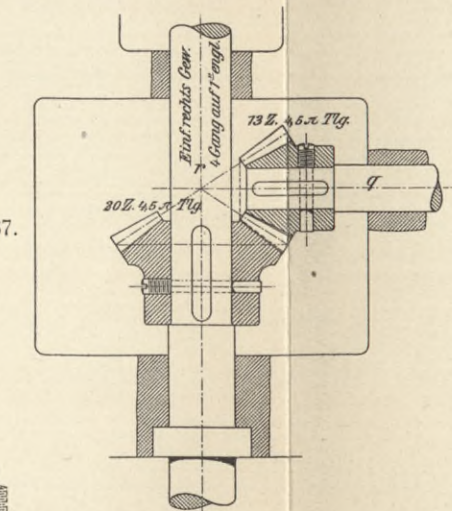

Fig. 568.

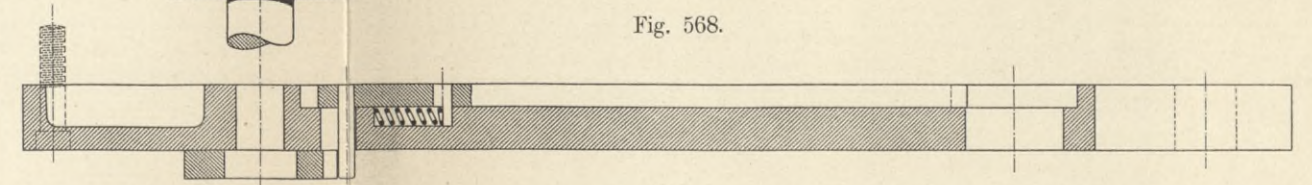



Fig. 618 u. 619: Achshalsdrehbank von Ernst Schiess in Düsseldorf. 1/20 wahrer Grösse.

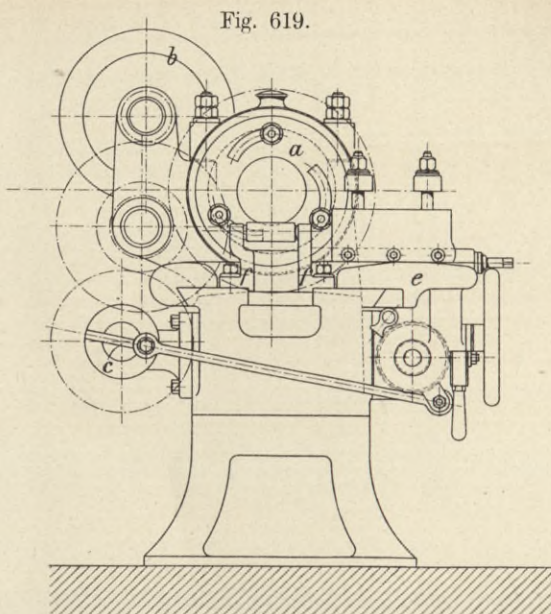
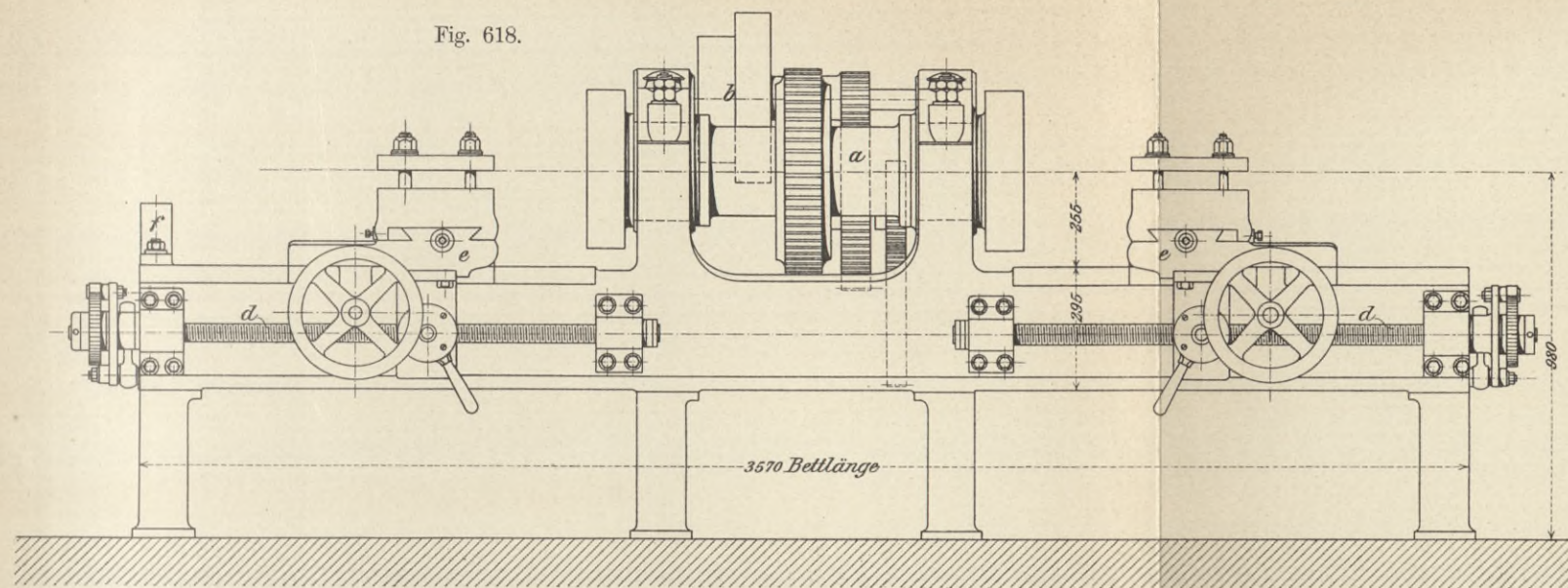
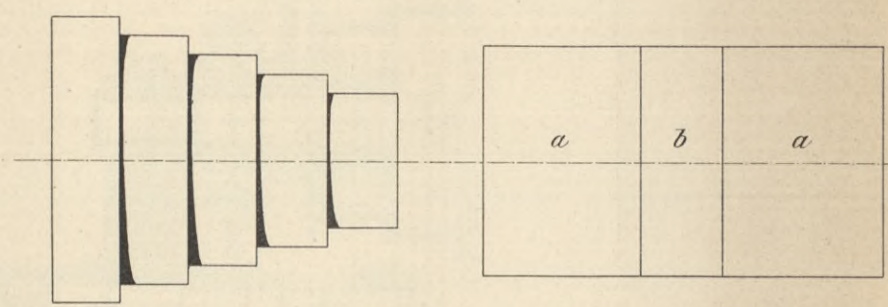
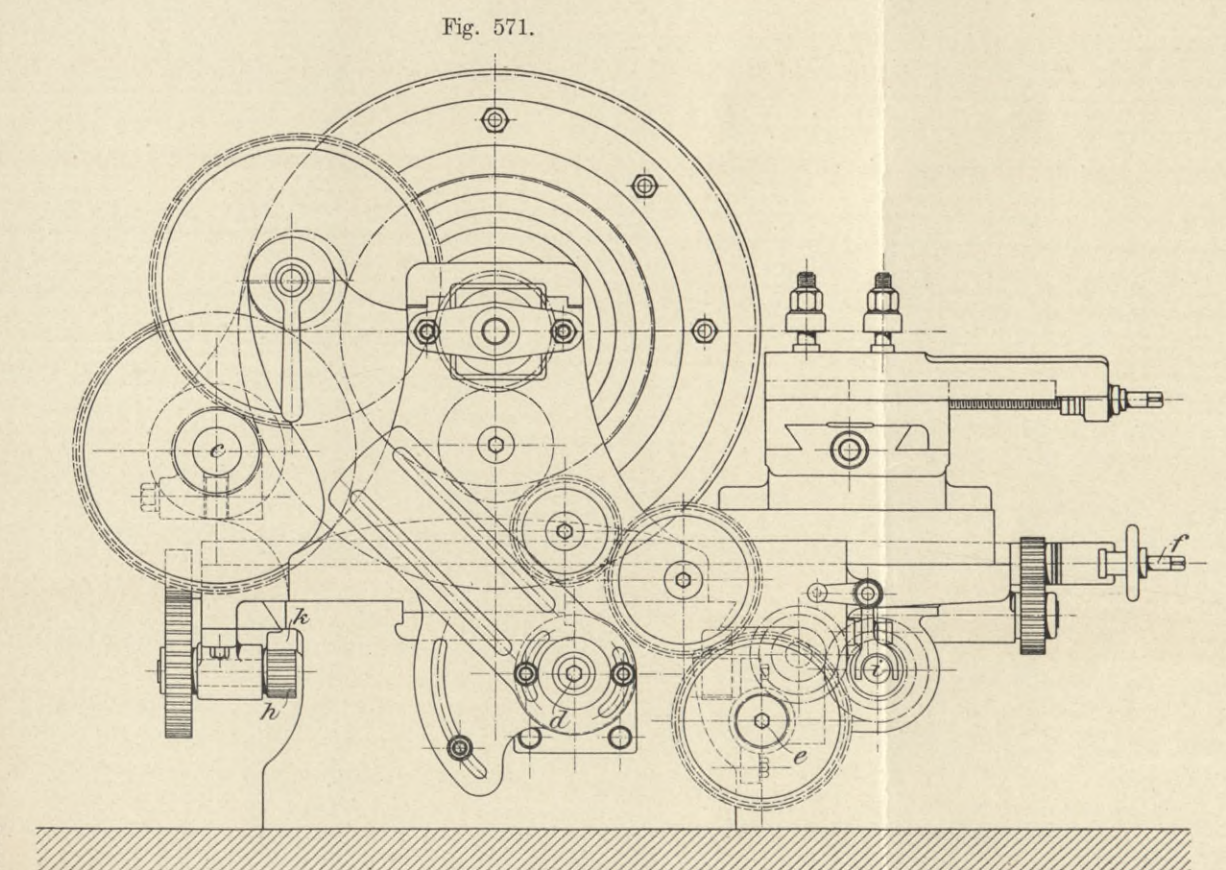
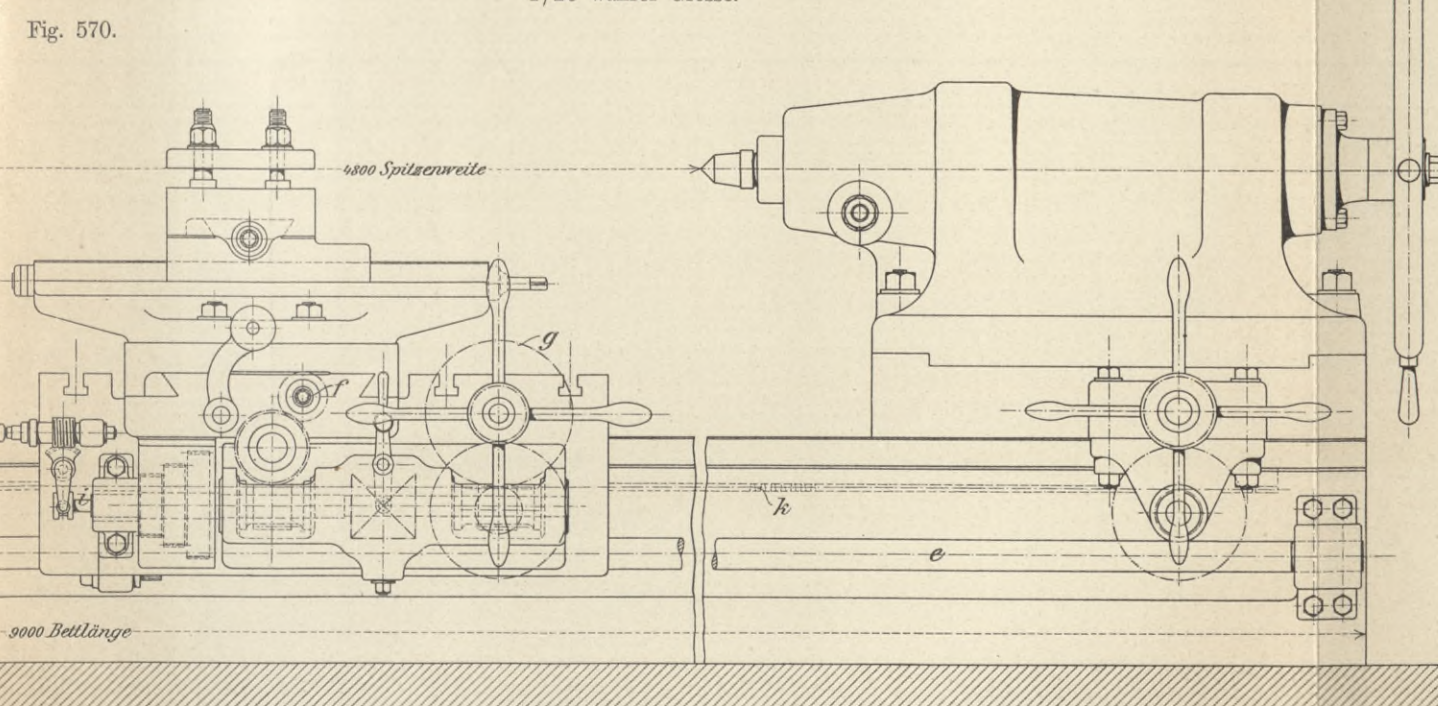
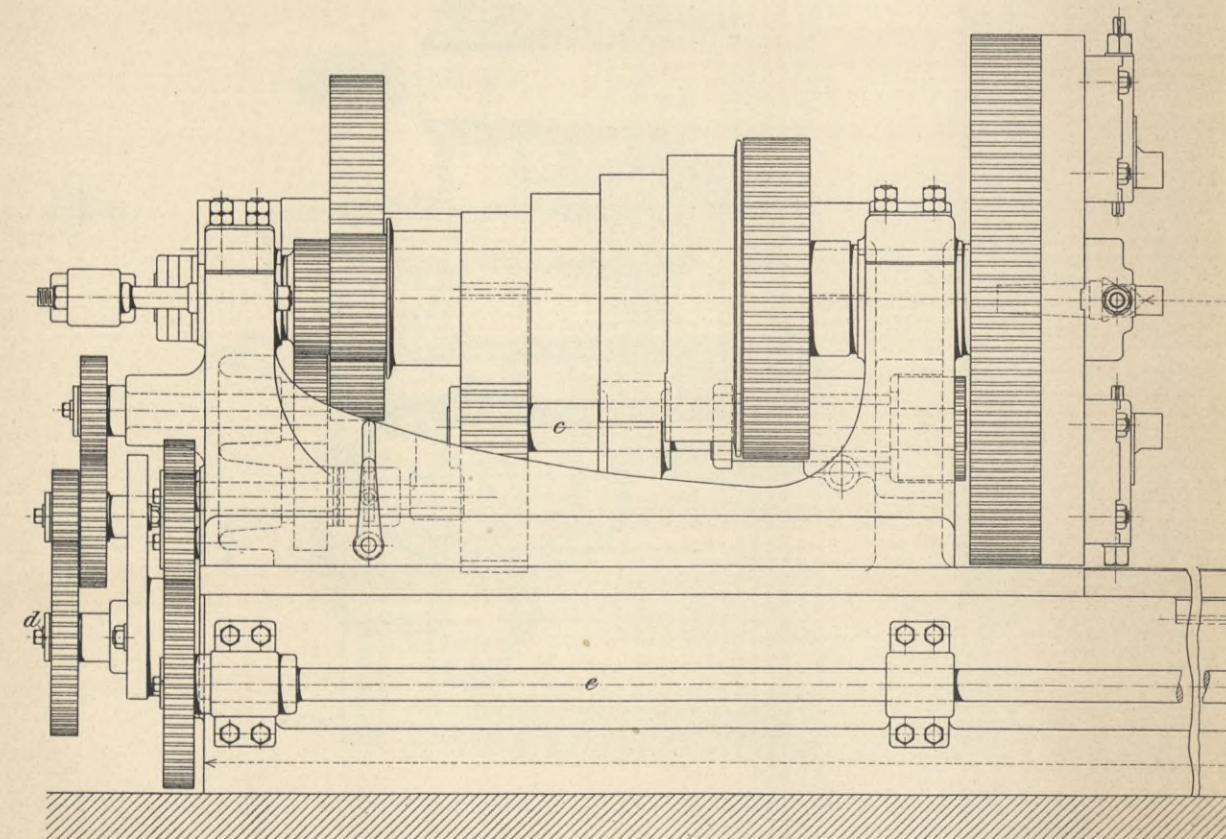

Fig. 570 u. 571: Plan- und Spitzendrehbank von Ernst Schiess in Düsseldorf. 1/20 wahrer Grösse.





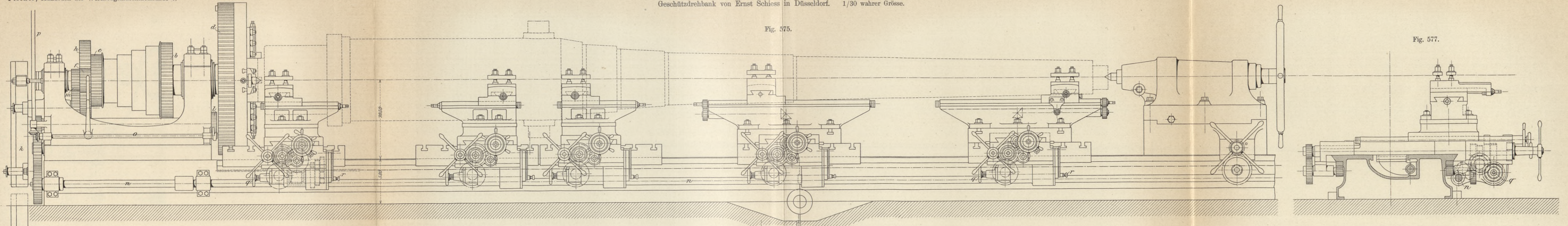

Fig. 575.

Fig. 577.

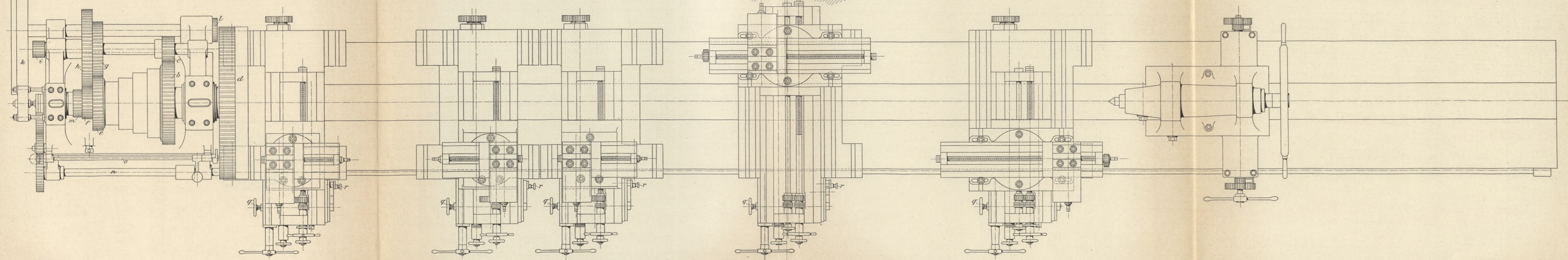

Fig. 576.



Fig. 578-580. Kurbelwellendrehbank von Ernst Schiess in Düsseldorf. 1/30 wahrer Grösse.

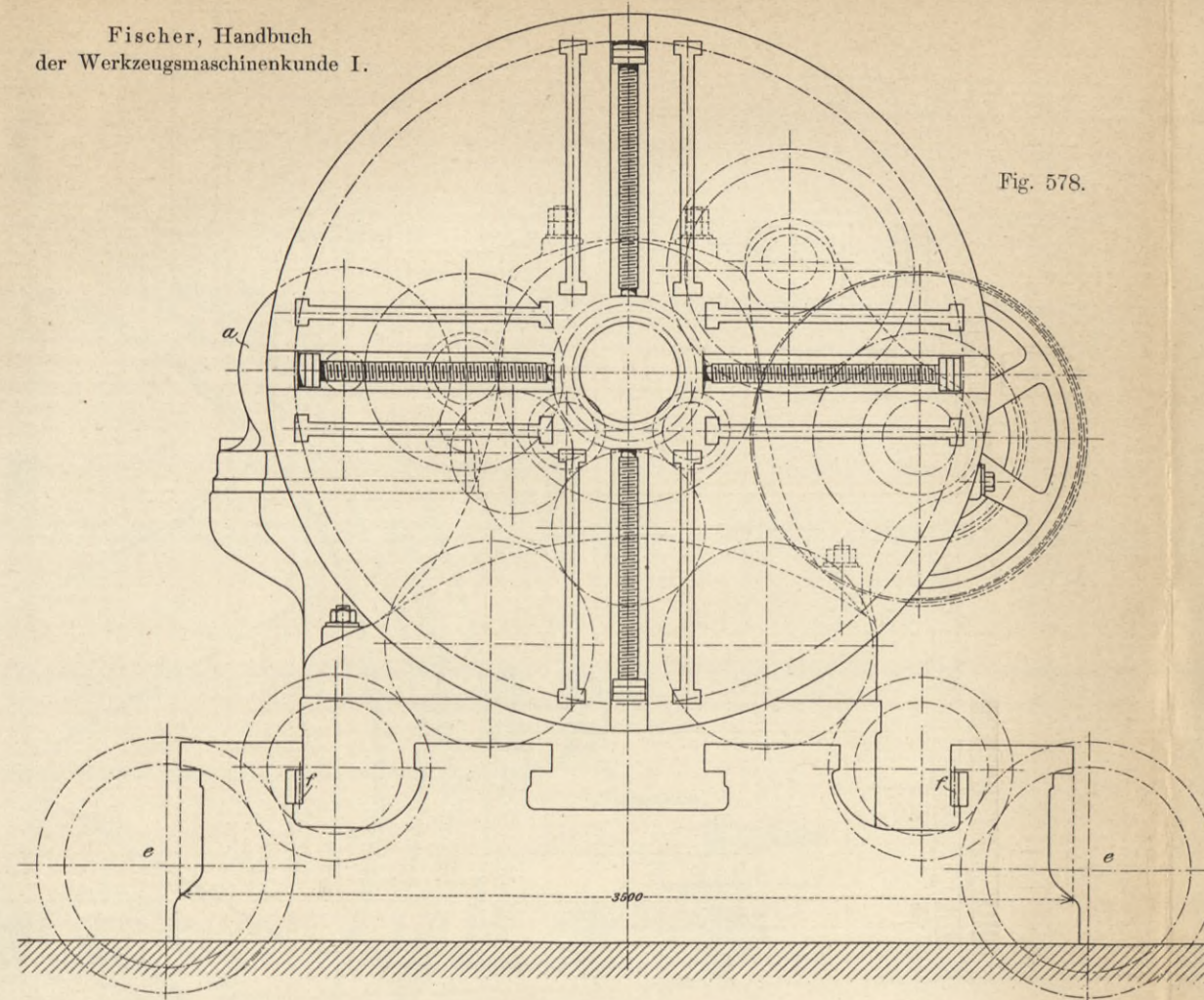

Fig. 578.

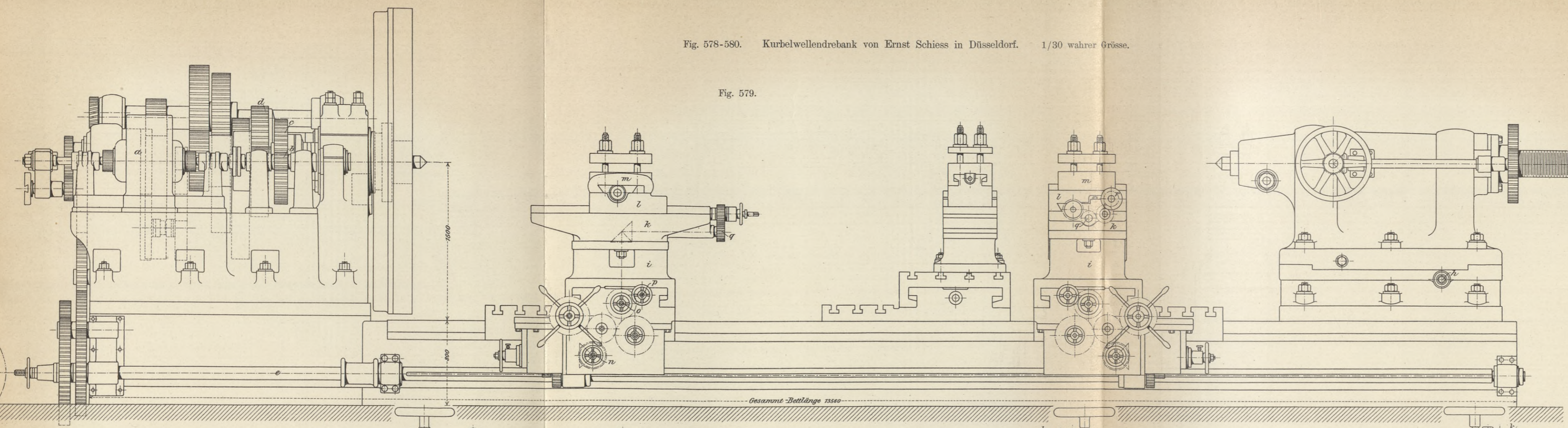

Fig. 579.

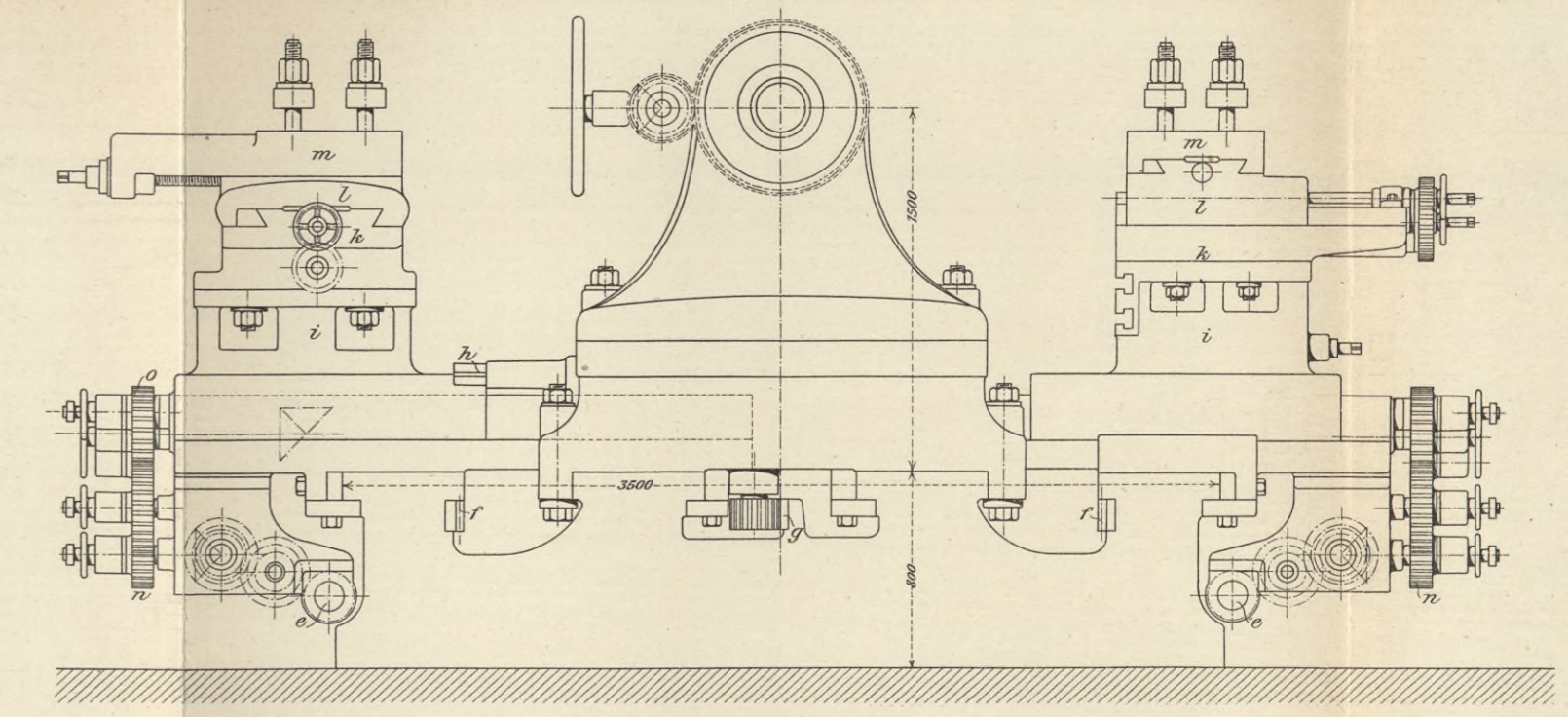

Fig. 580.

Gesamtlänge 13500

Fig. 661.

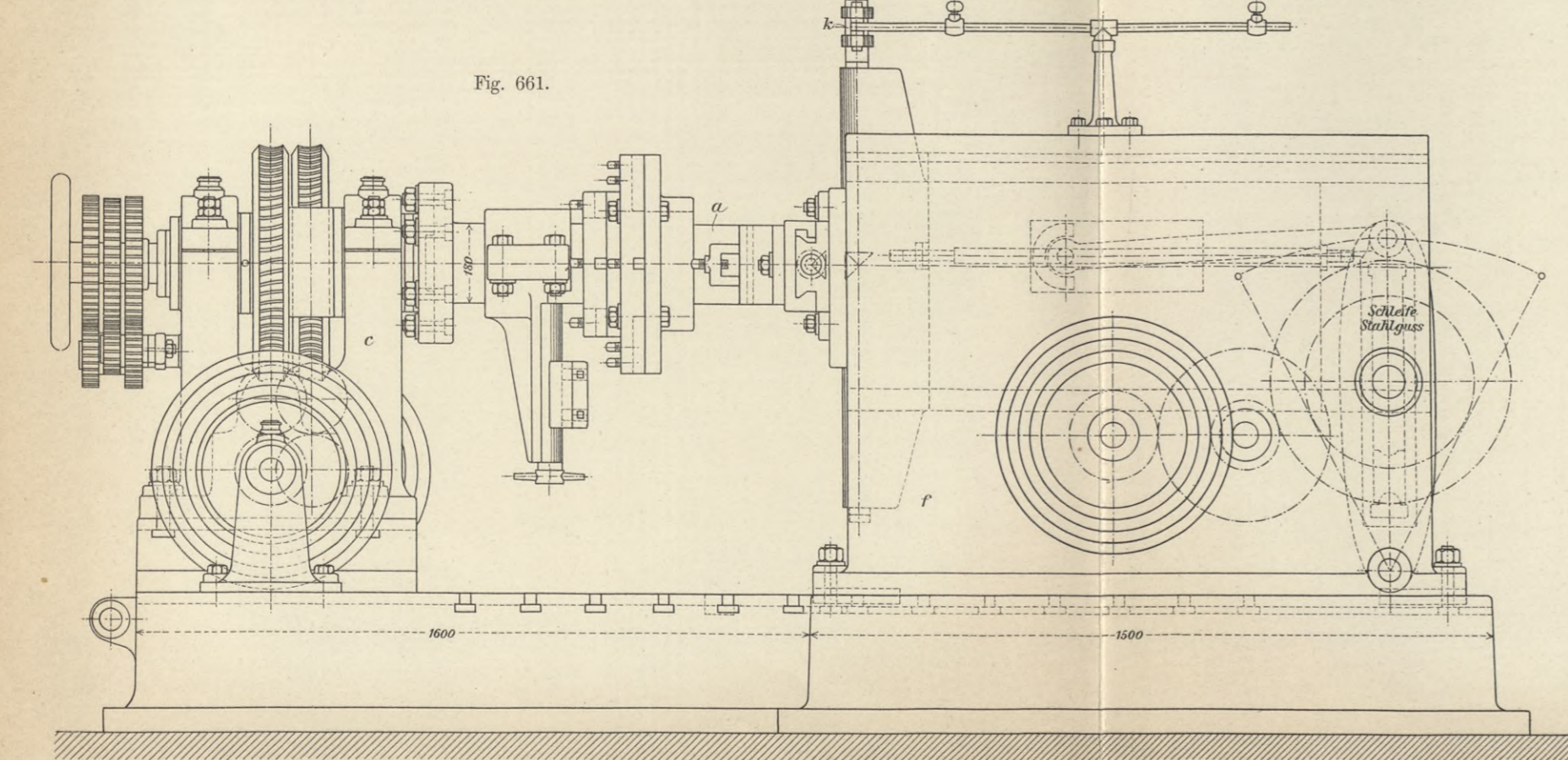

Fig. 662.

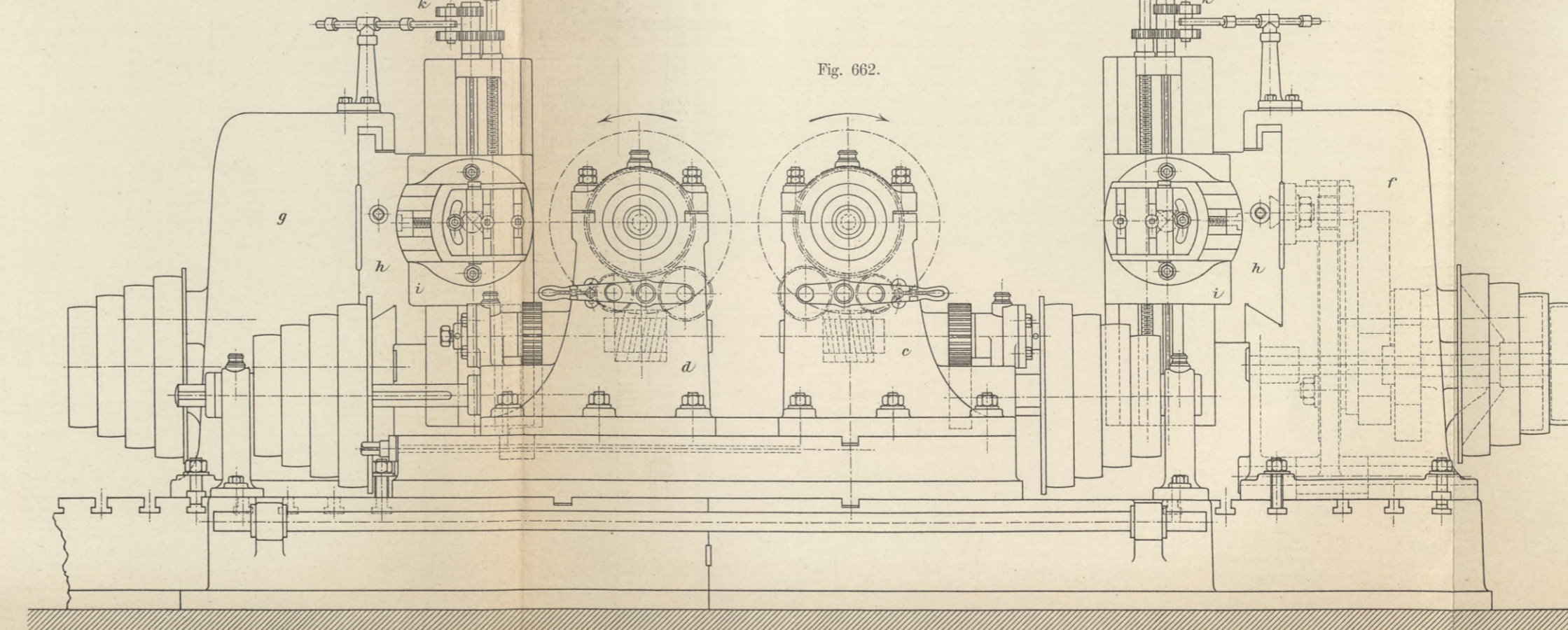

Fig. 661 u 662.
Ausbohrmaschine
von H. Wohlenberg in Hannover.
1/20 wahrer Grösse.



Räderdrehbank
von Ernst Schiess in Düsseldorf.
1/15 wahrer Grösse.

Fig. 582.

2500

1200

450

Fig. 583.

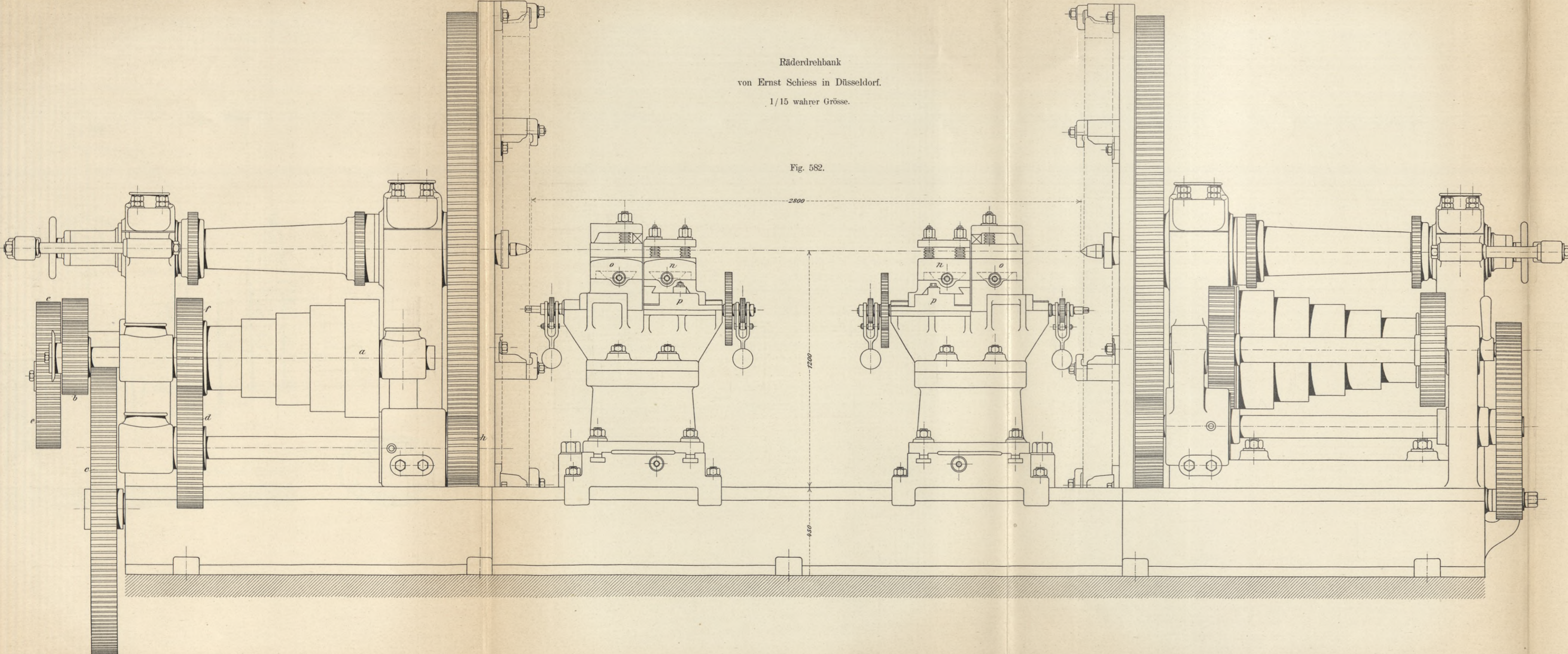
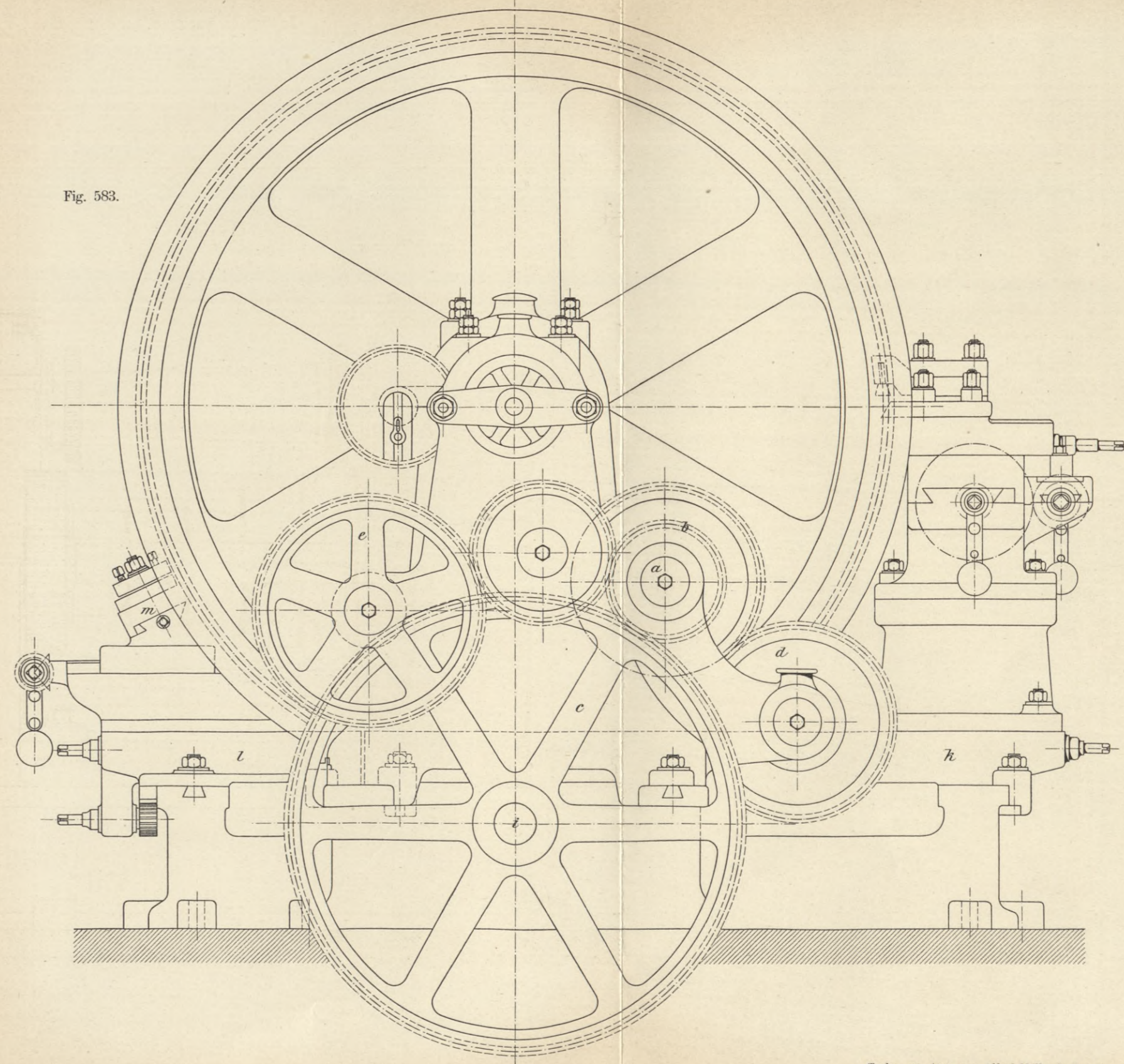



Riemenrollendrehbank
von H. Hessenmüller in Ludwigshafen.
1/10 wahrer Grösse.

Fig. 585.

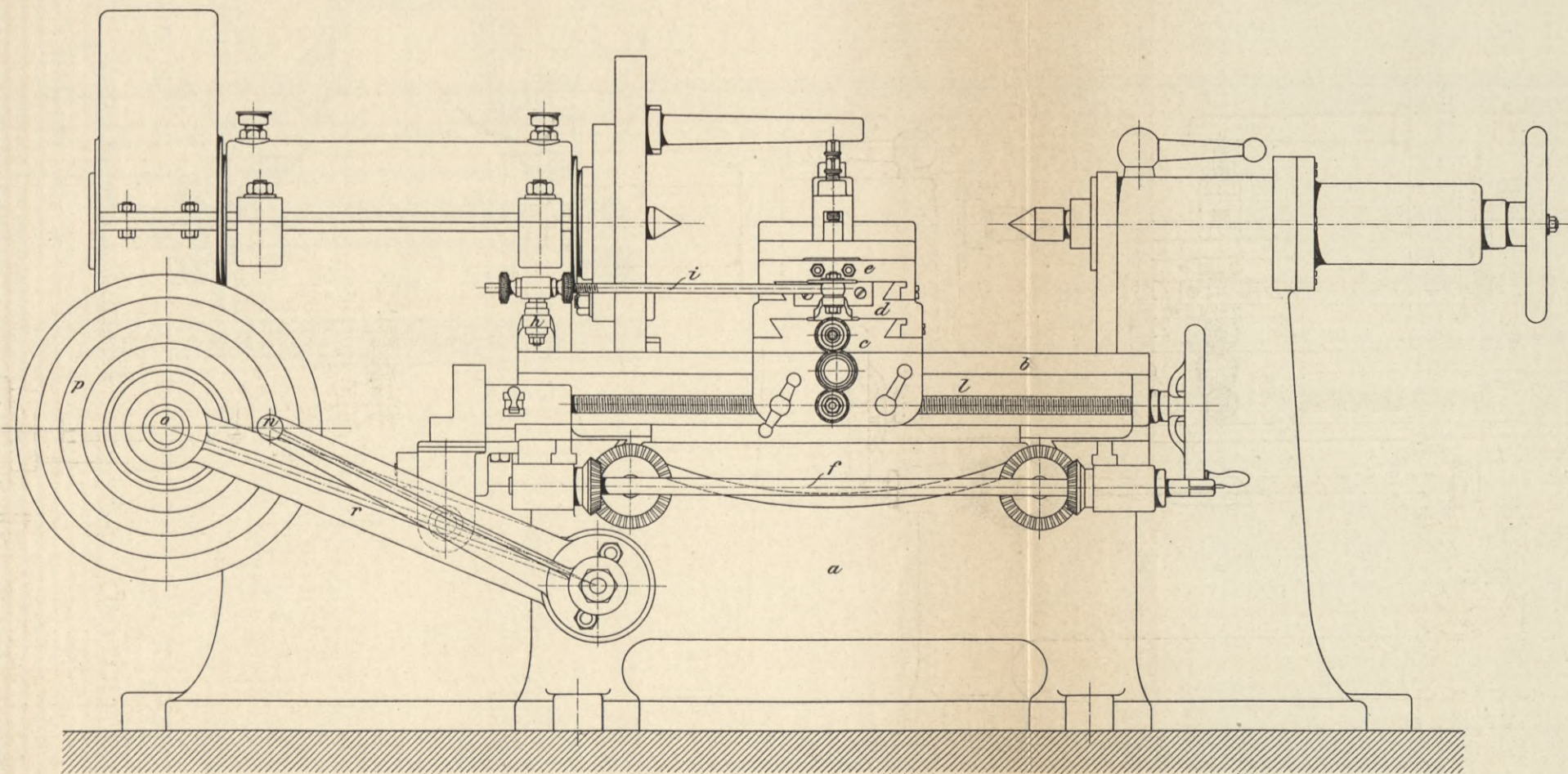

Fig. 586.

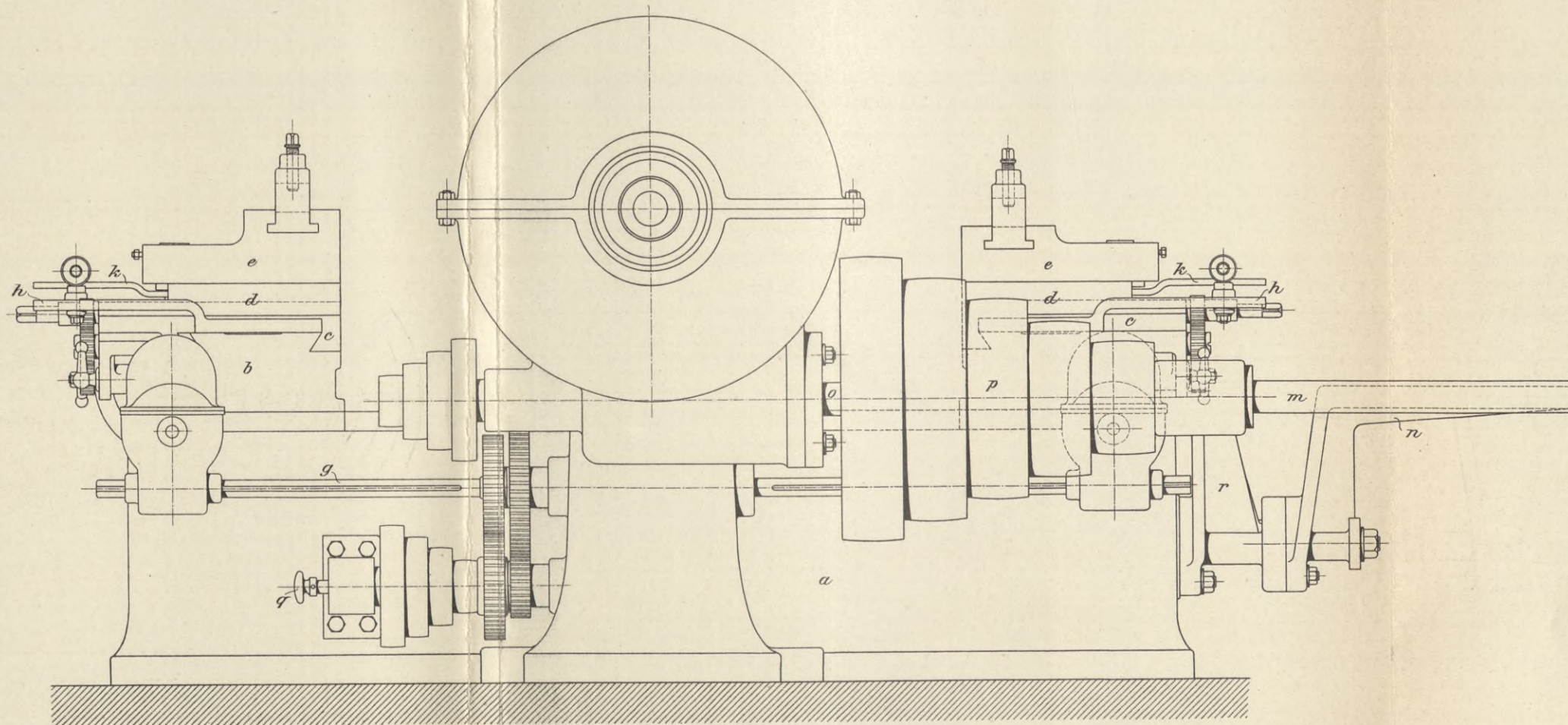



Fig. 629.

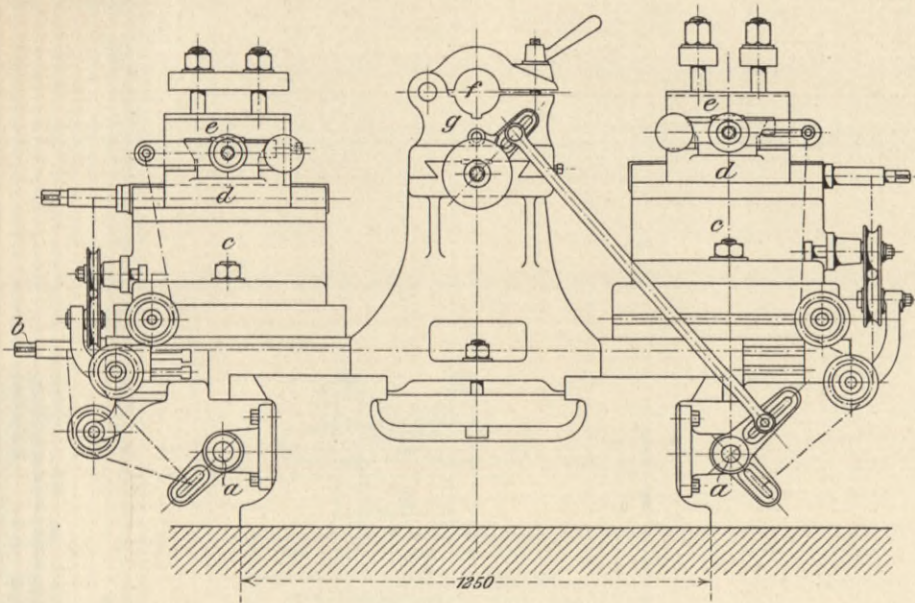

Fig. 627.

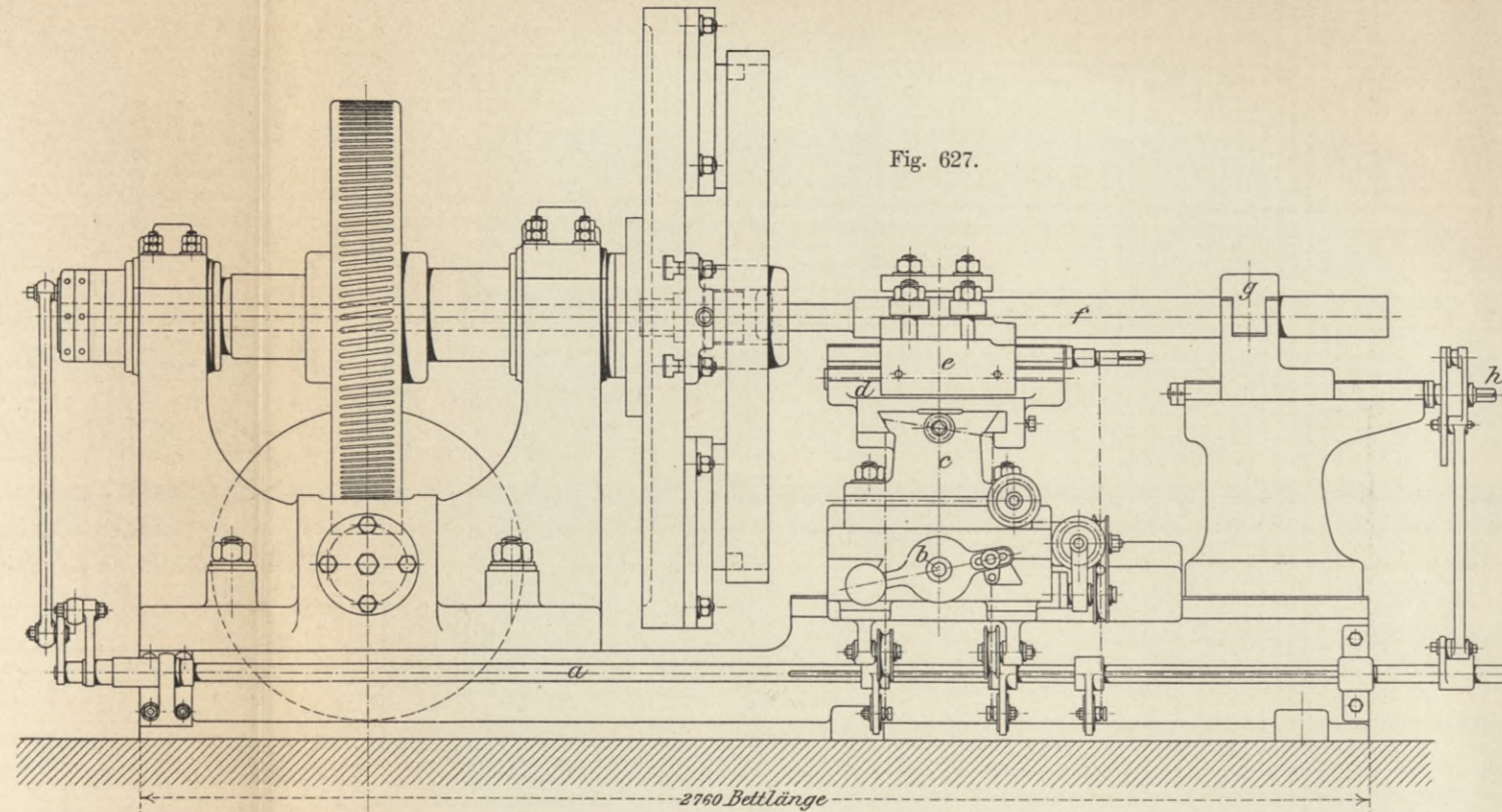
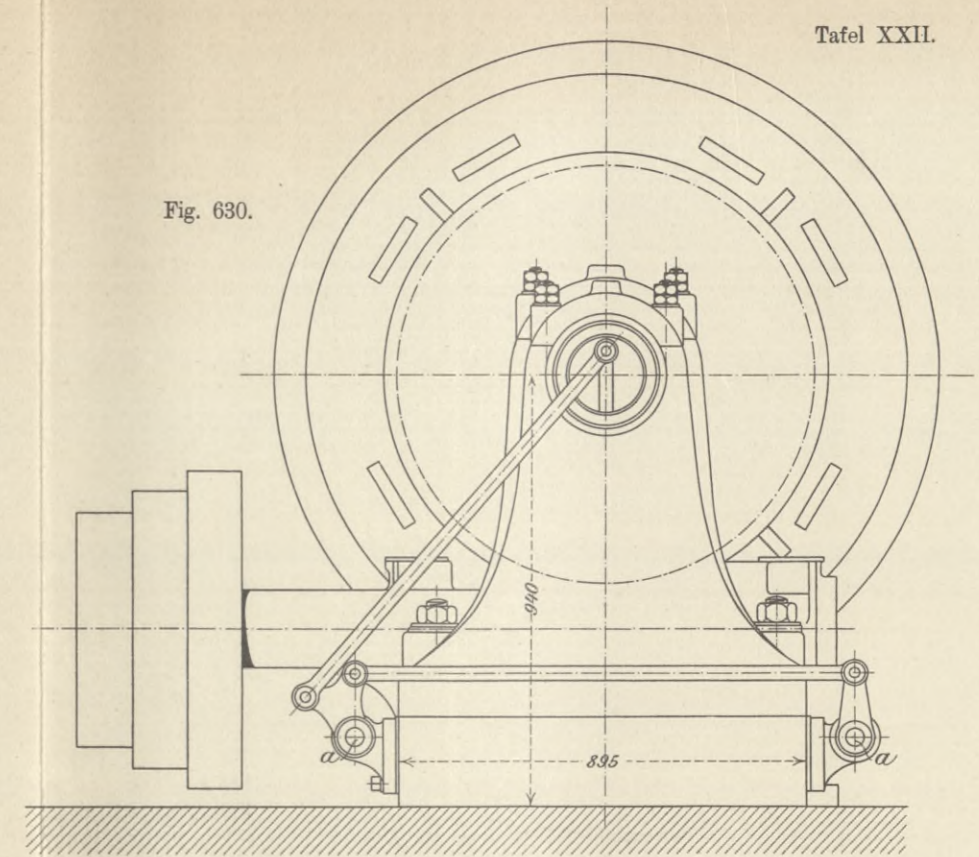

Fig. 630.



Radstern - Drehbank
 von Ernst Schiess in Düsseldorf.
 0,06 der wahren Grösse.

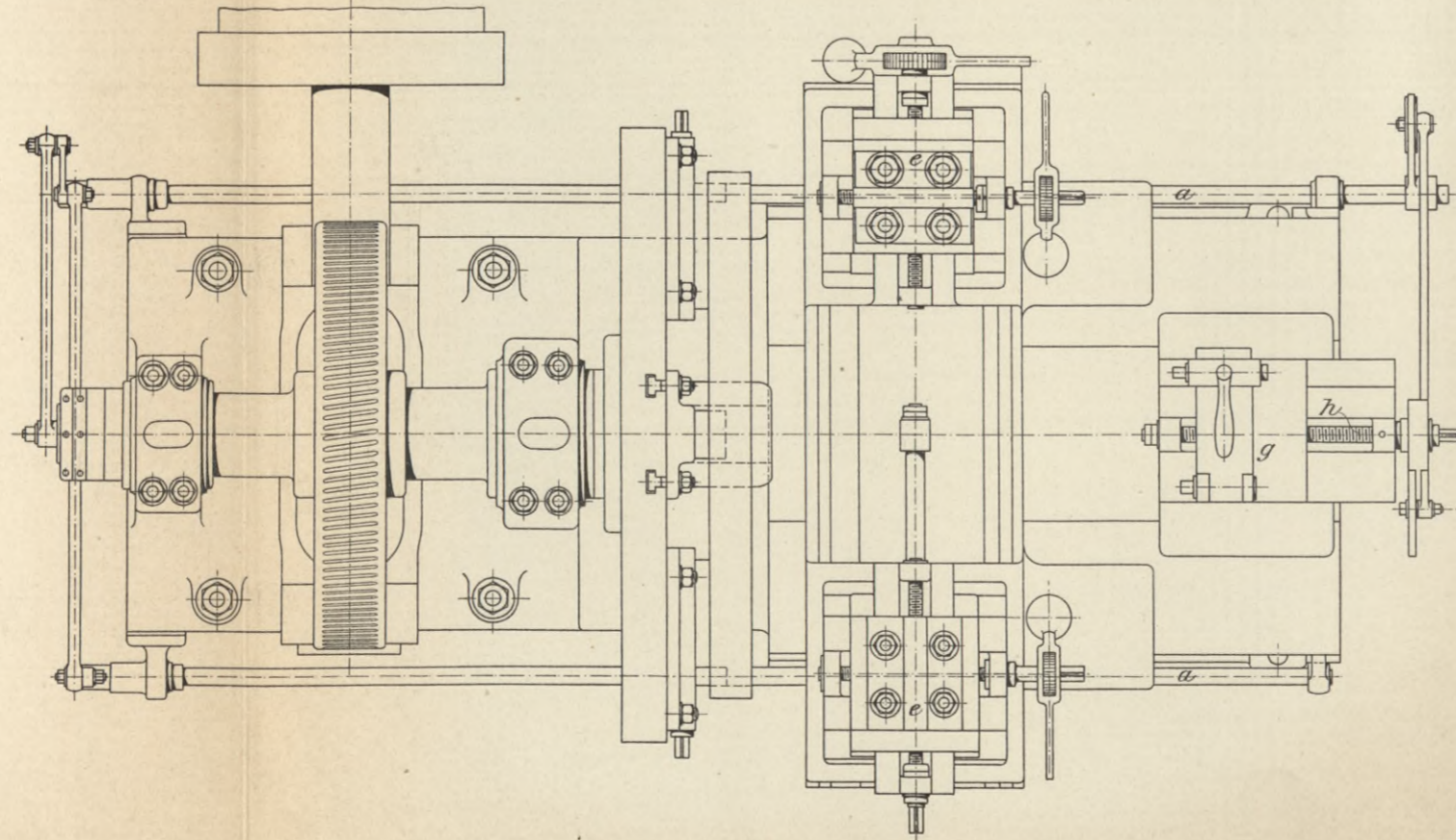

Fig. 628.





Antrieb der Planscheibendrehbank von Droop & Rein in Bielefeld.
 1/10 wahrer Grösse.

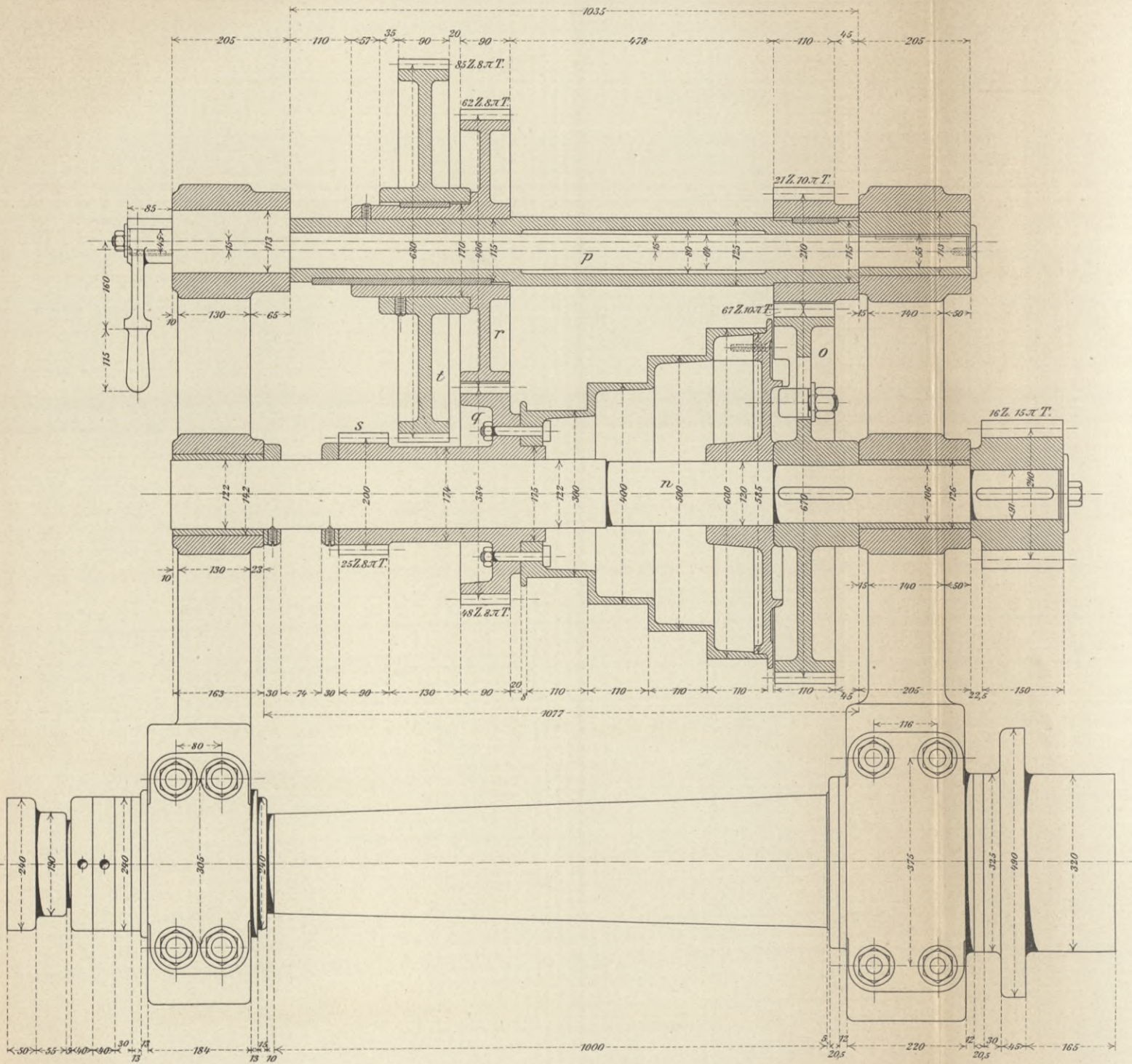

Fig. 633.



Fig. 634.

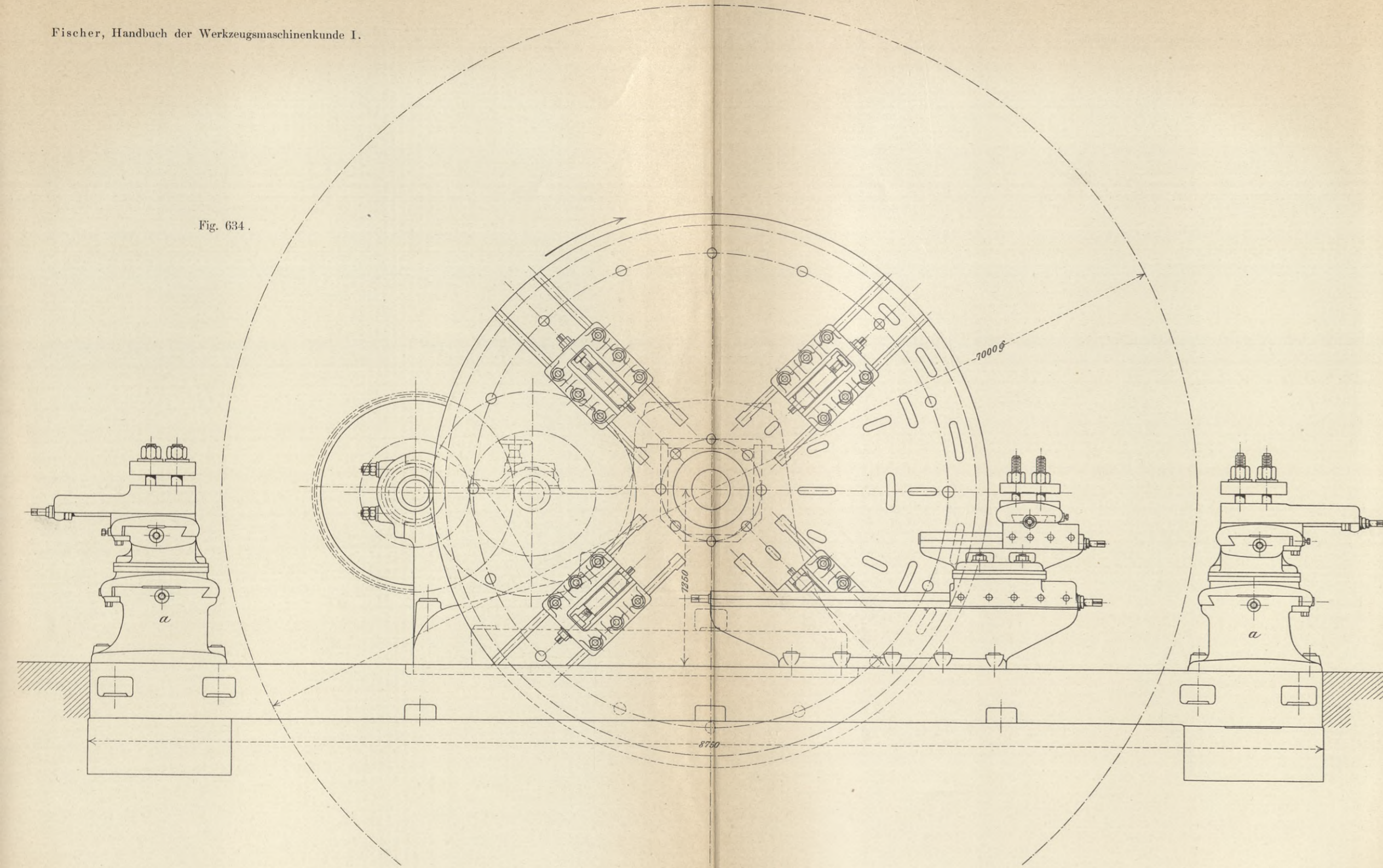
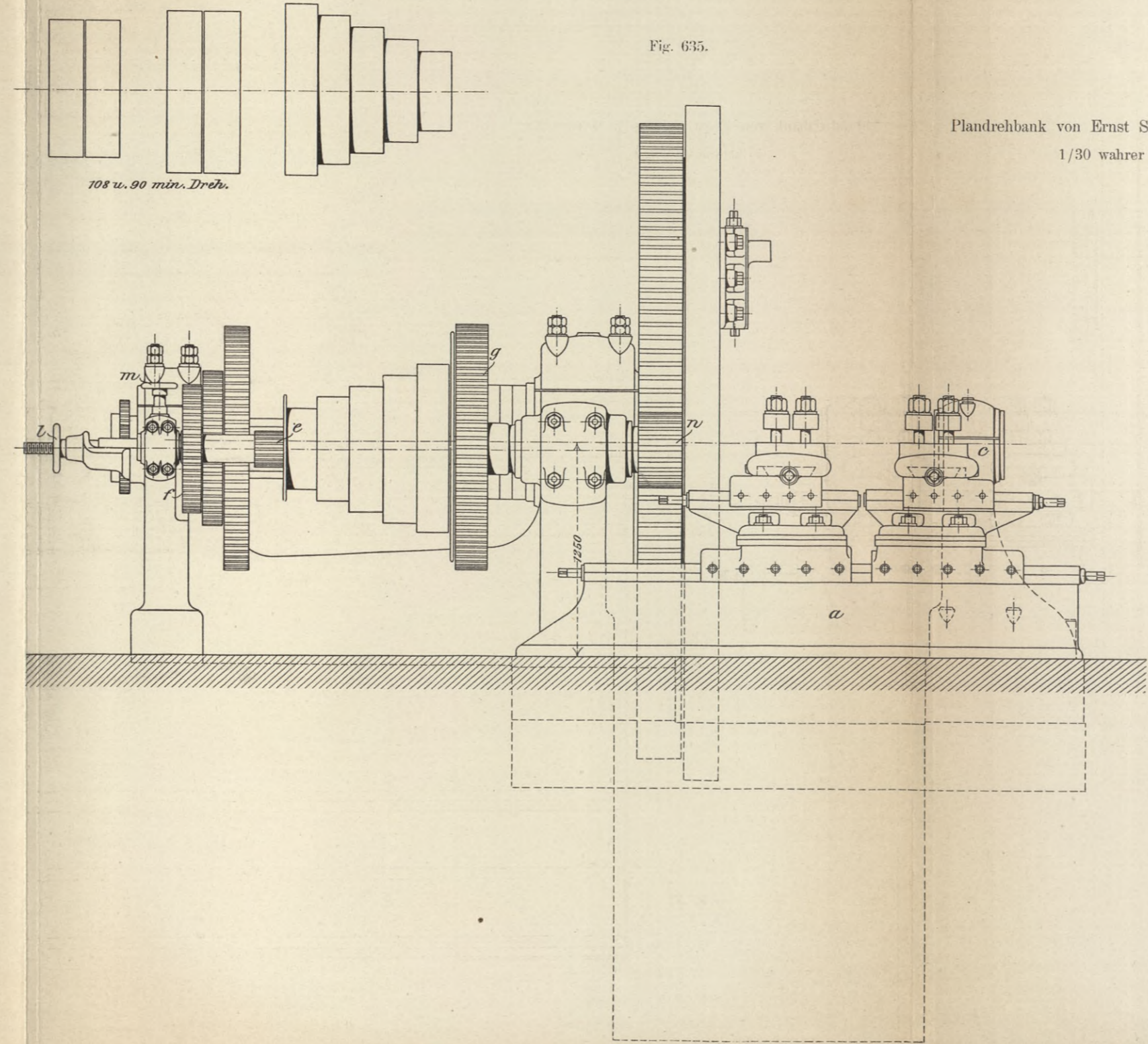
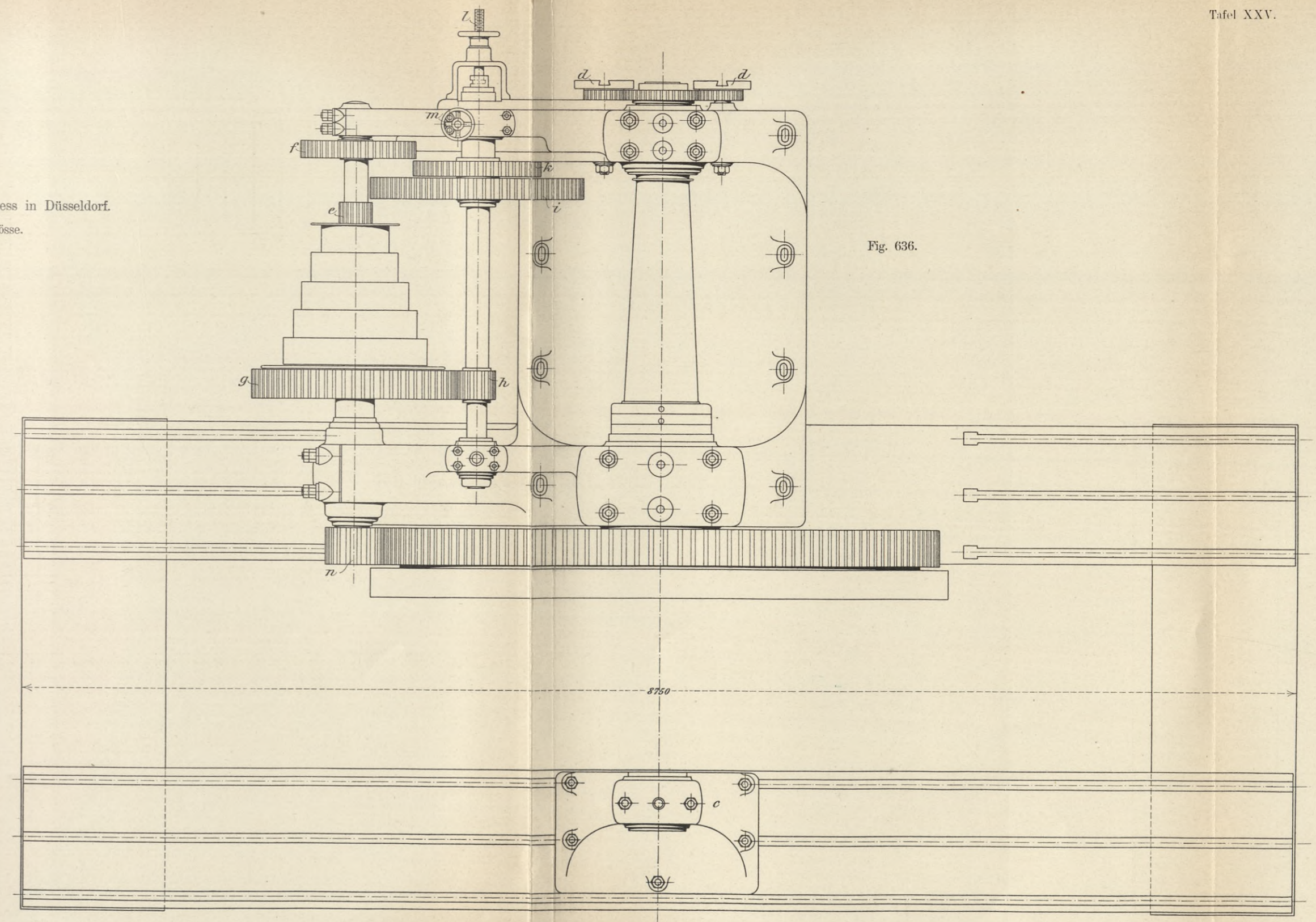

Fig. 635.



Plandrehbank von Ernst Schiess in Düsseldorf.
1/30 wahrer Grösse.

Fig. 636.





BIBLIOTEKA
KRAKÓW
Politechniczna

Fig. 640.

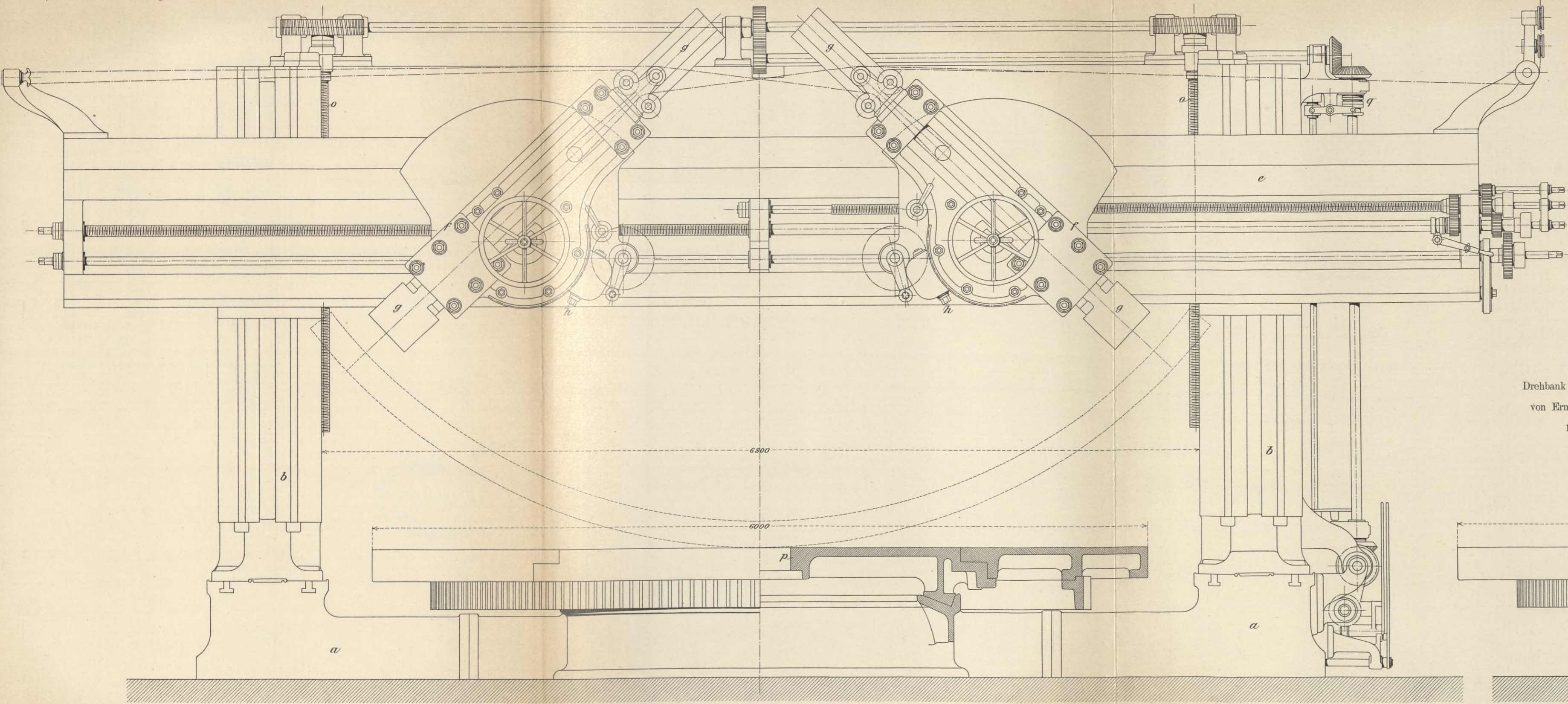

Drehbank mit liegender Planscheibe
von Ernst Schiess in Düsseldorf.
1/25 wahrer Grösse.

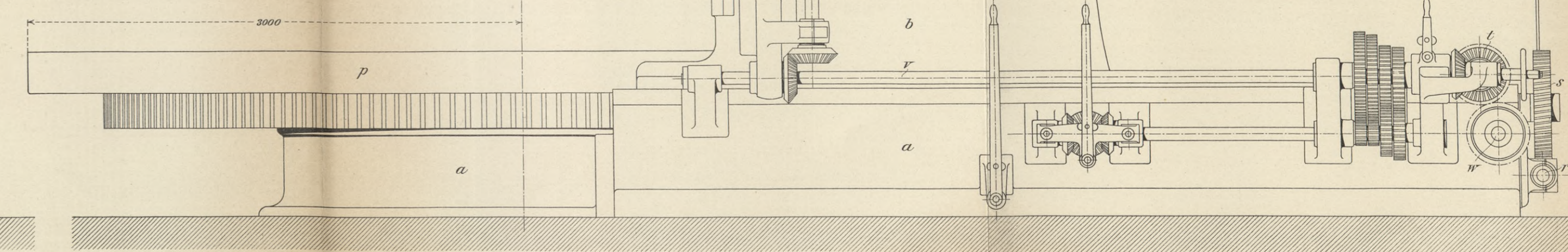

Fig. 641.

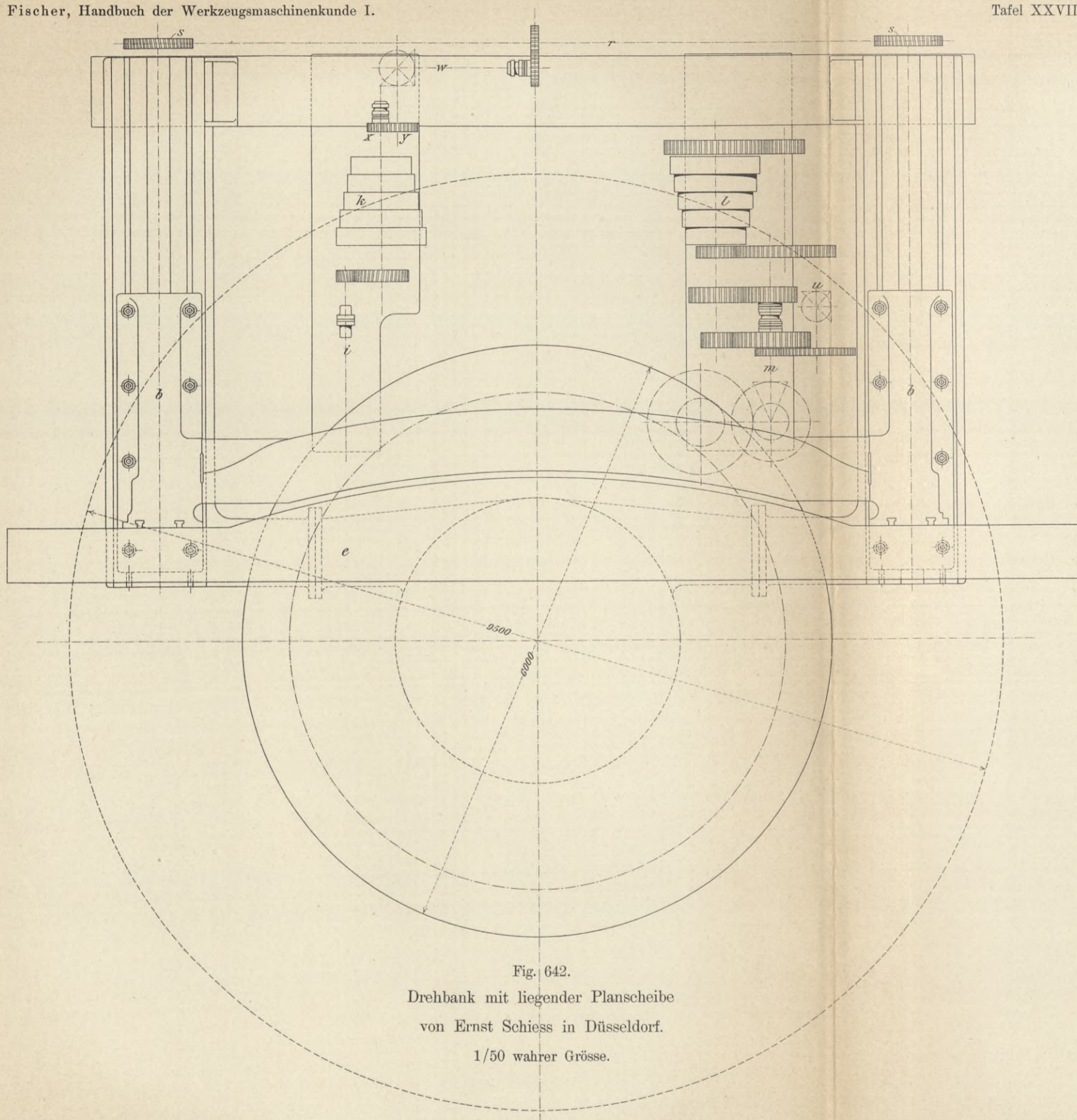

Fig. 642.

Drehbank mit liegender Planscheibe
von Ernst Schiess in Düsseldorf.

1/50 wahrer Grösse.



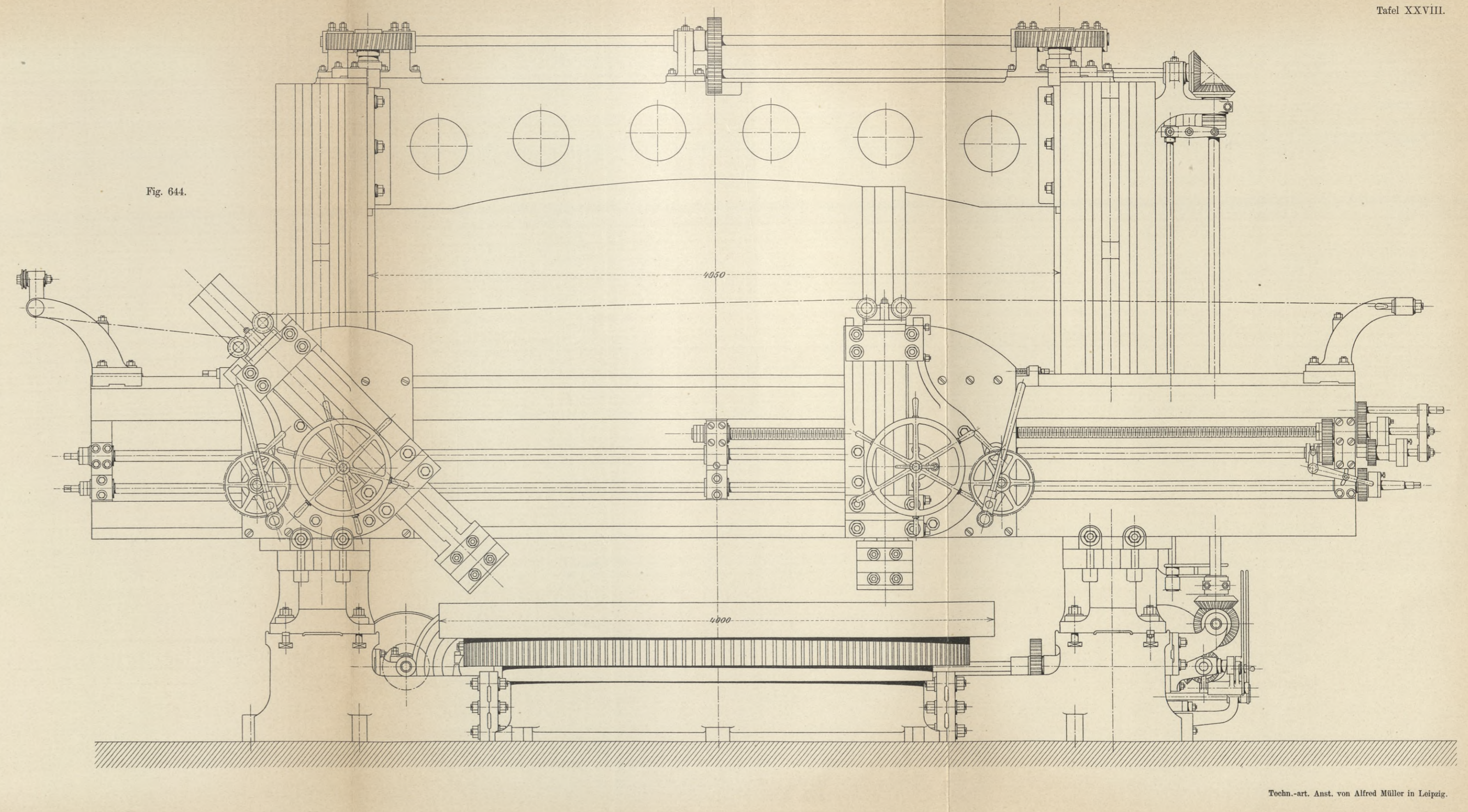
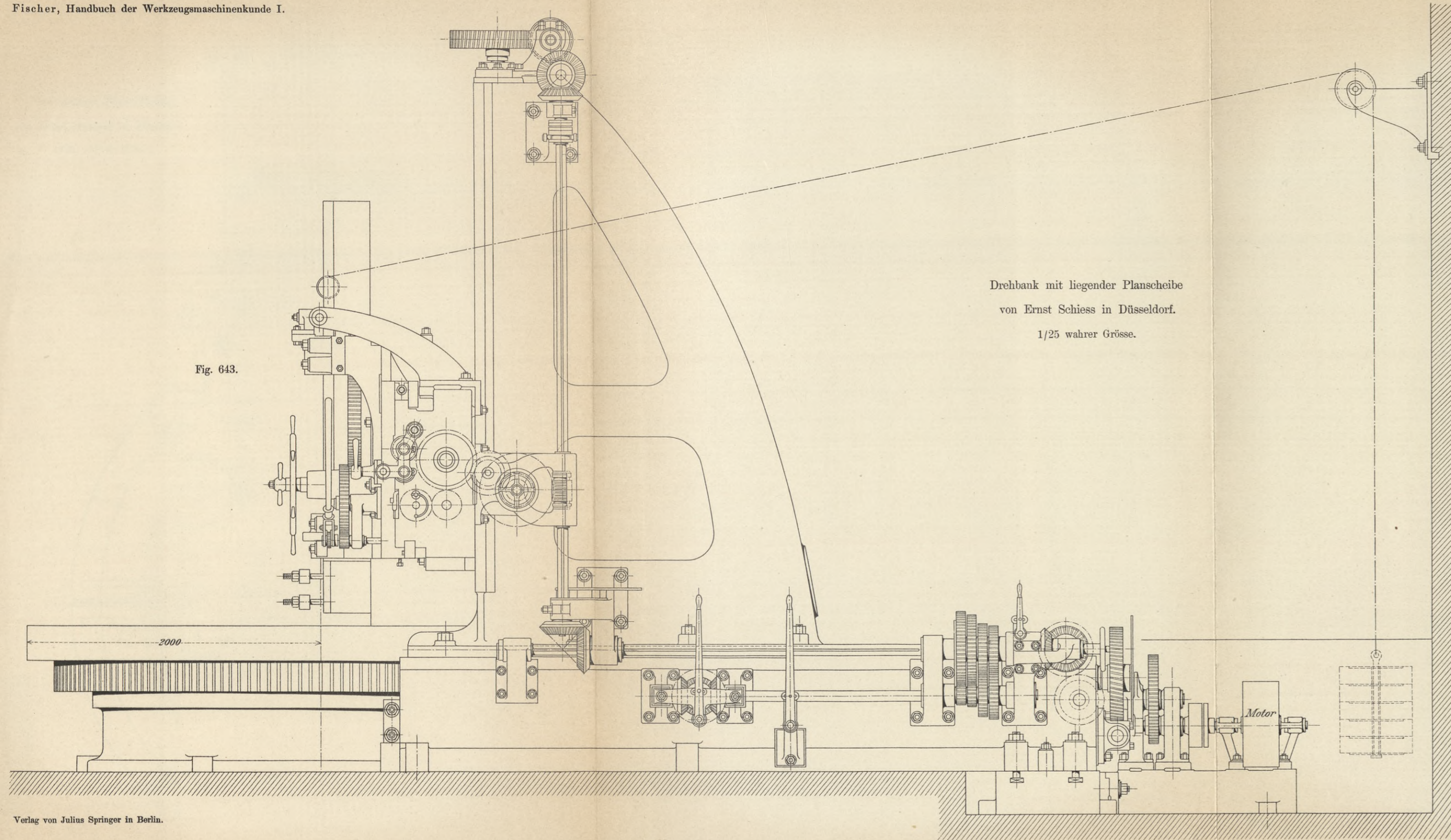
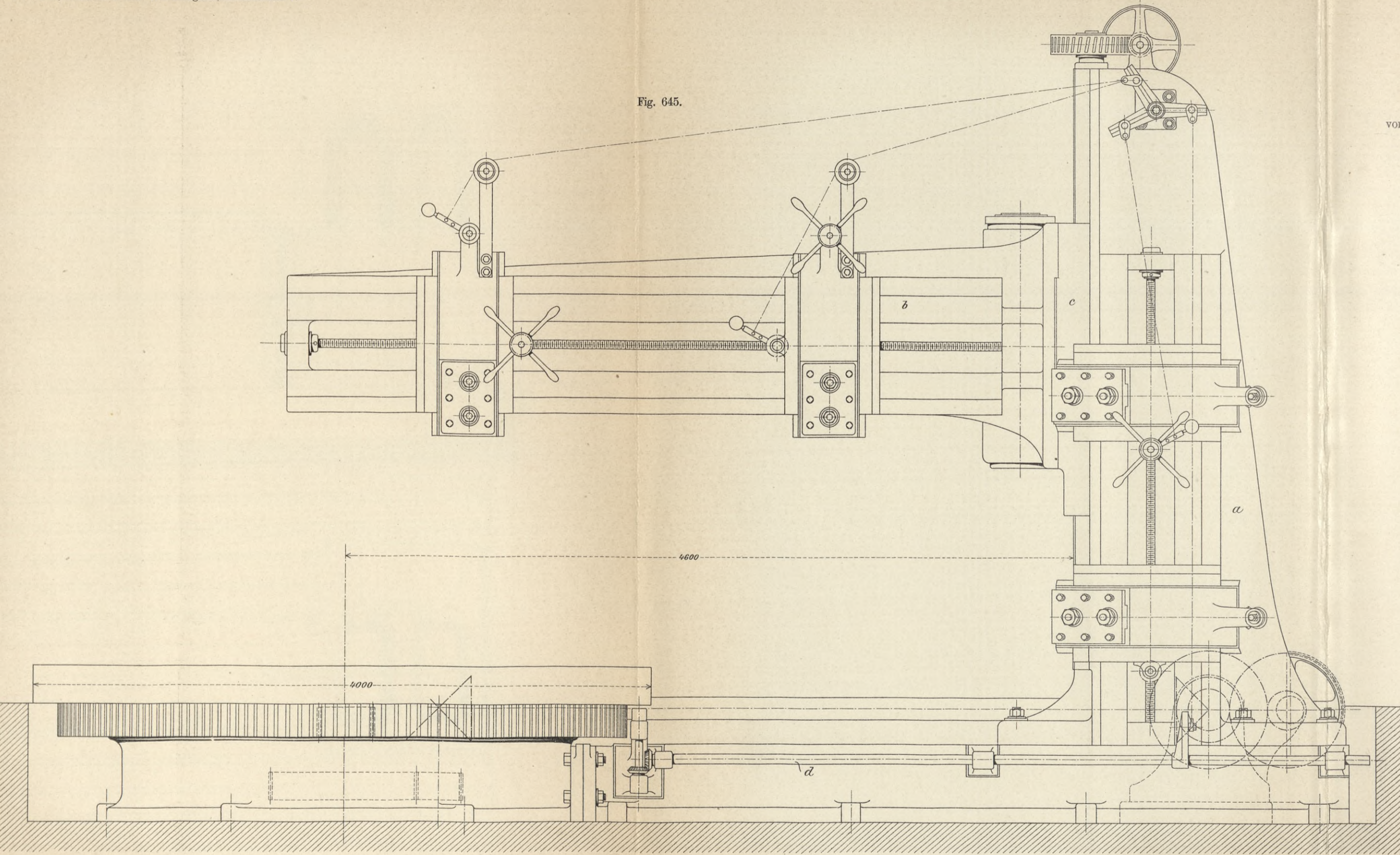
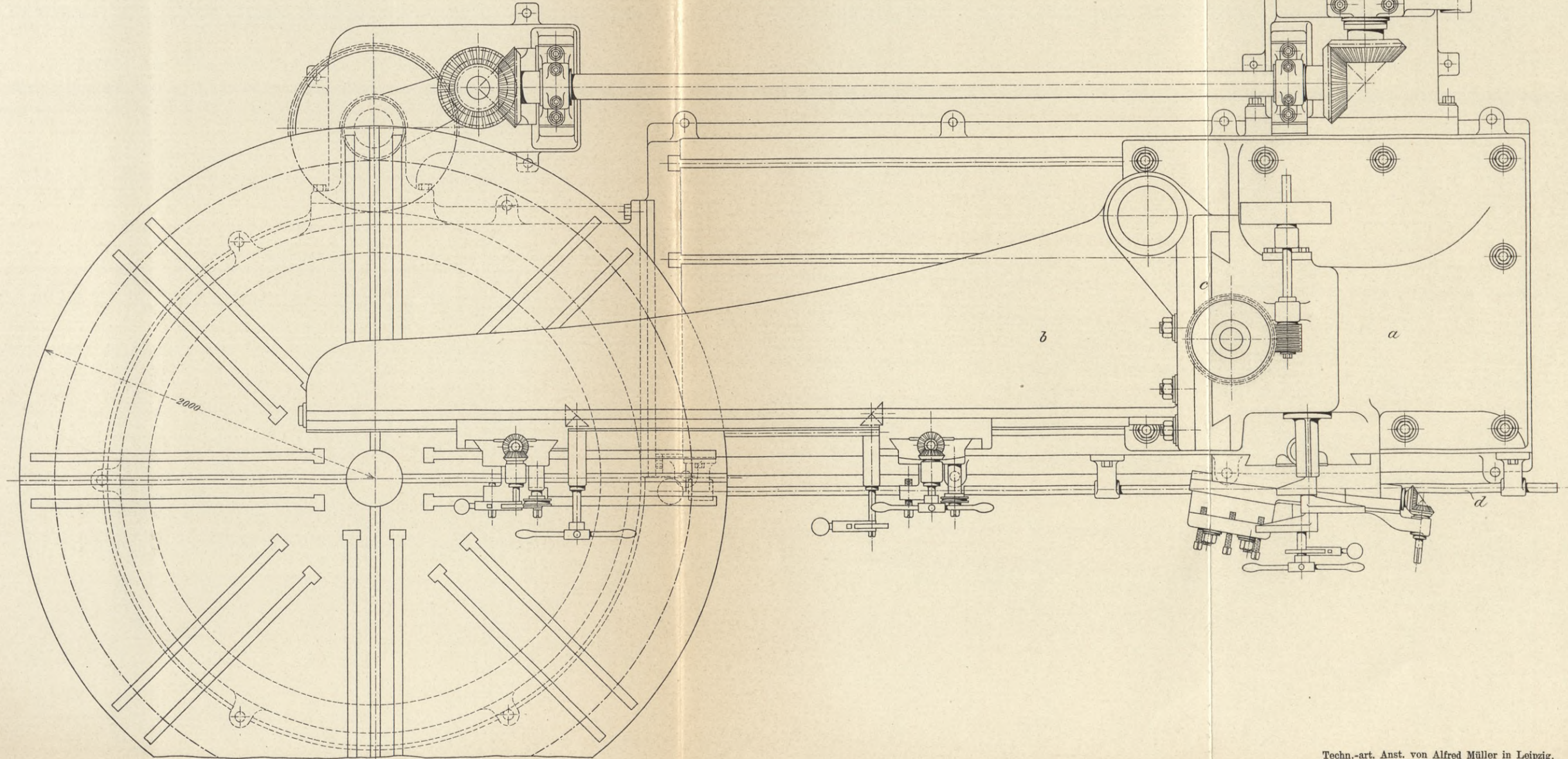

Fig. 645.



Einständige Plandrehbank
 von Ernst Schiess in Düsseldorf.
 1/25 wahrer Grösse.

Fig. 646.





Ausbohrmaschine von Ernst Schiess in Düsseldorf.

1/30 wahrer Grösse.

Fig. 650.

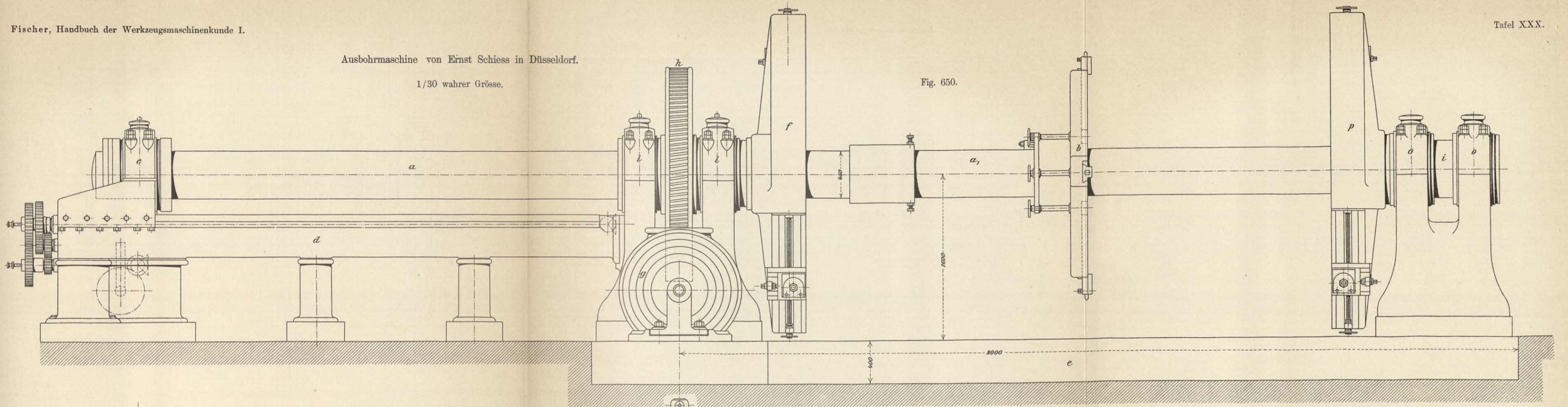

Fig. 651.

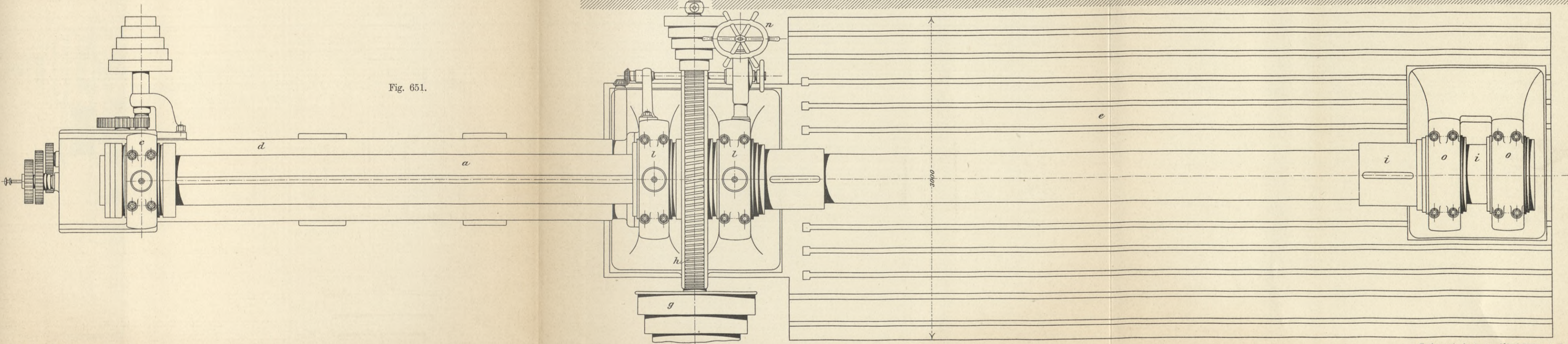



Fig. 656.

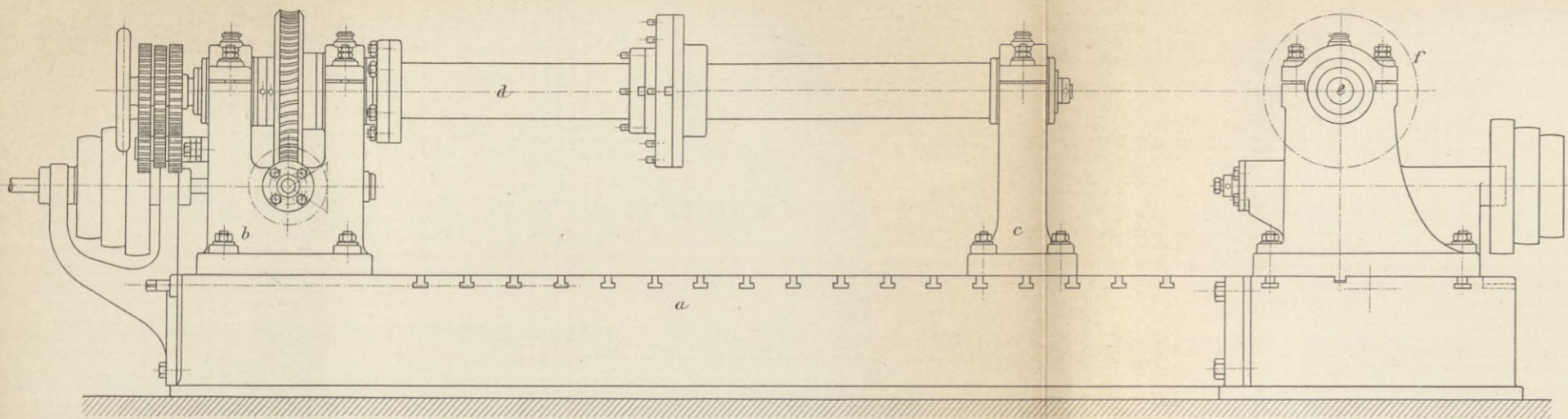

Fig. 657.

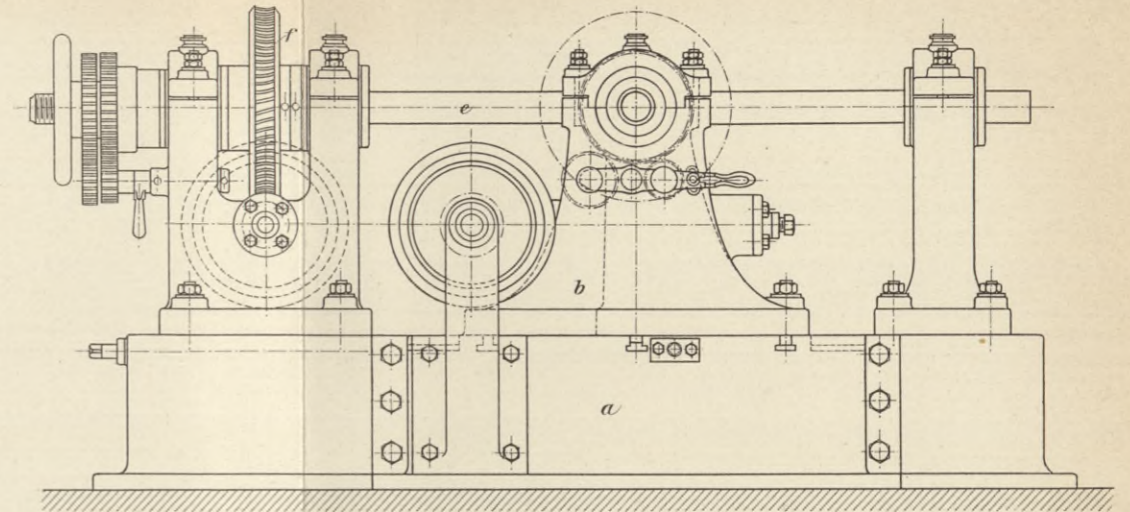
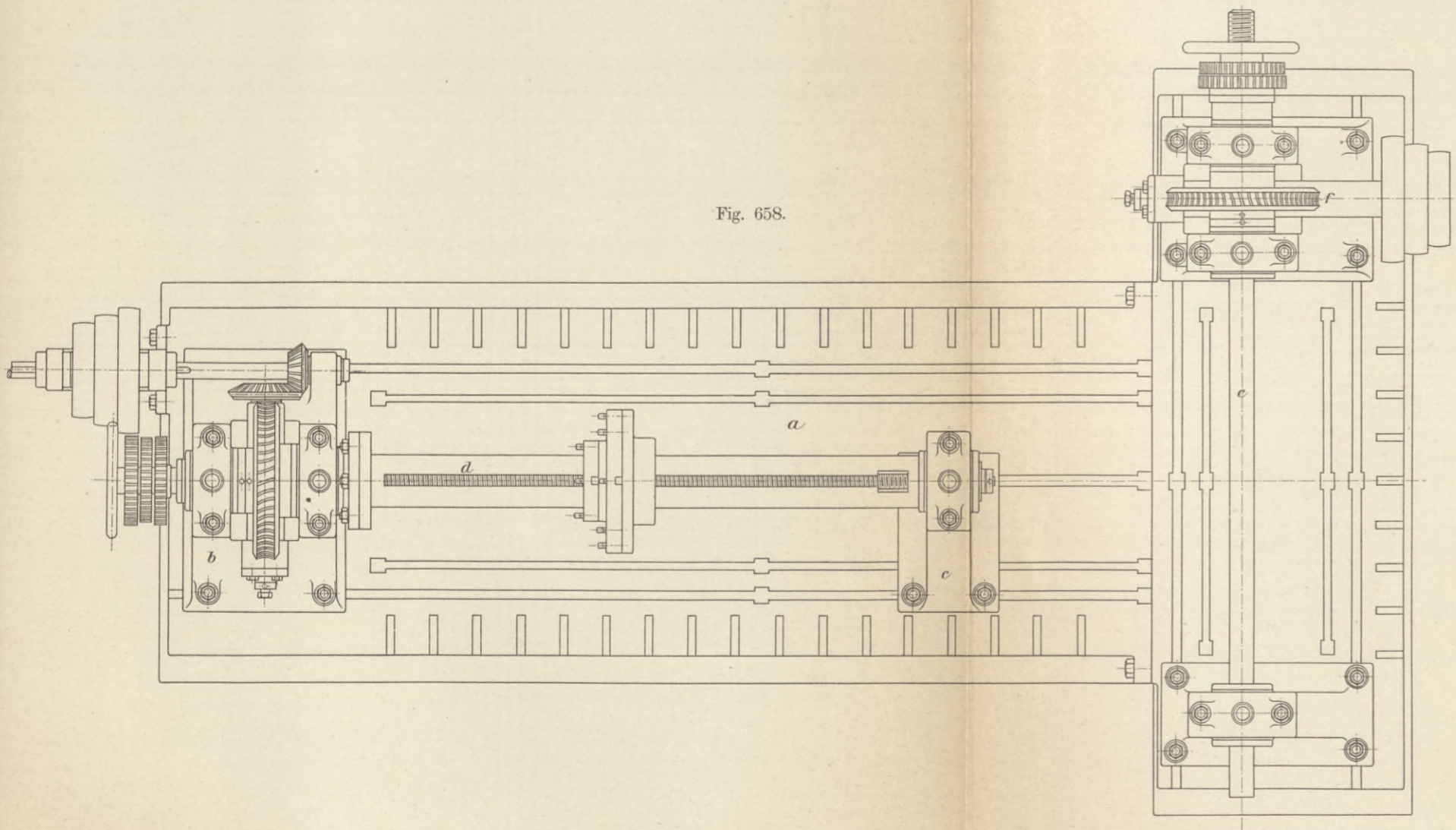

Fig. 658.



Ausbohrmaschine
 von H. Wohlenberg in Hannover.
 1/20 wahrer Grösse.







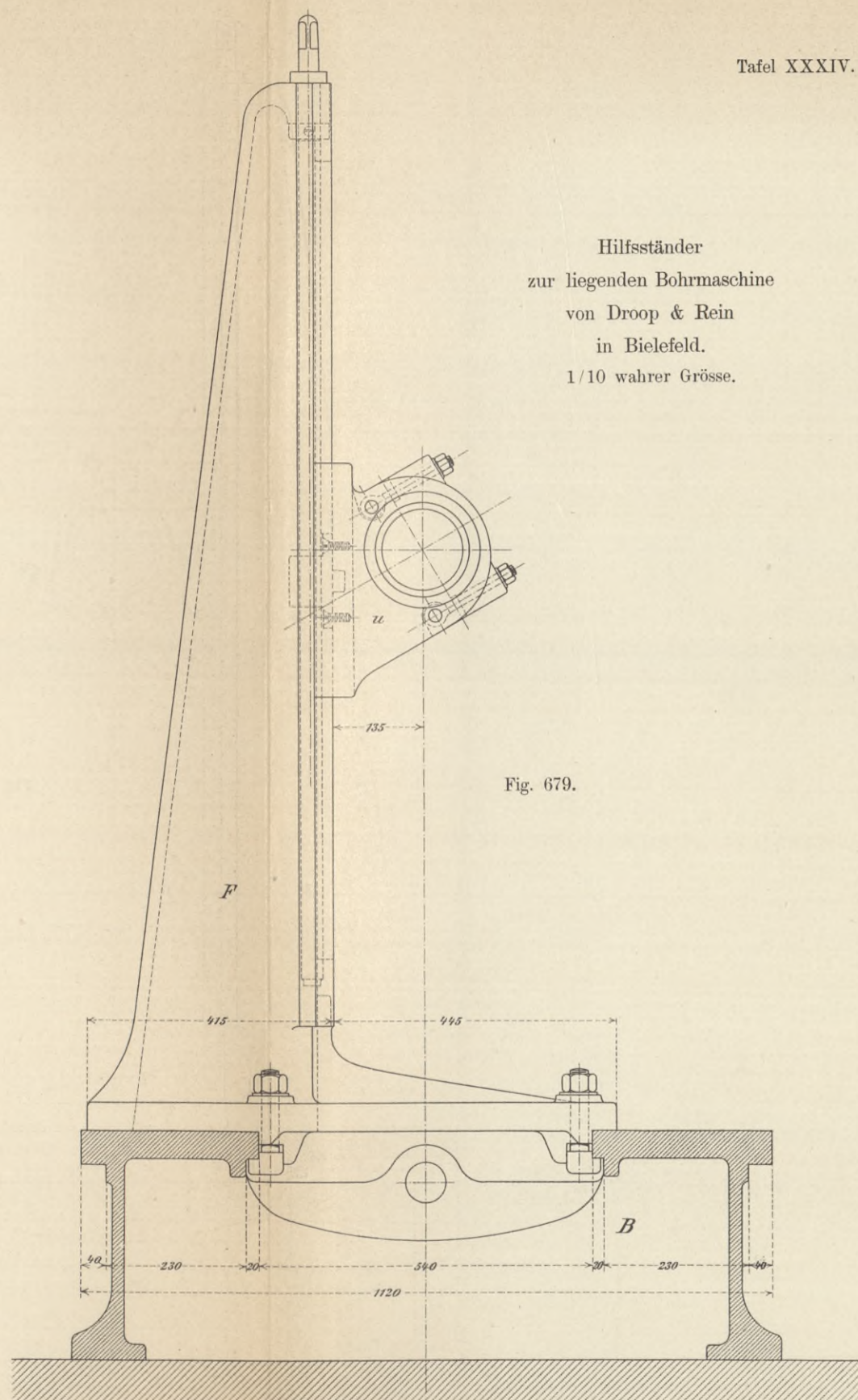
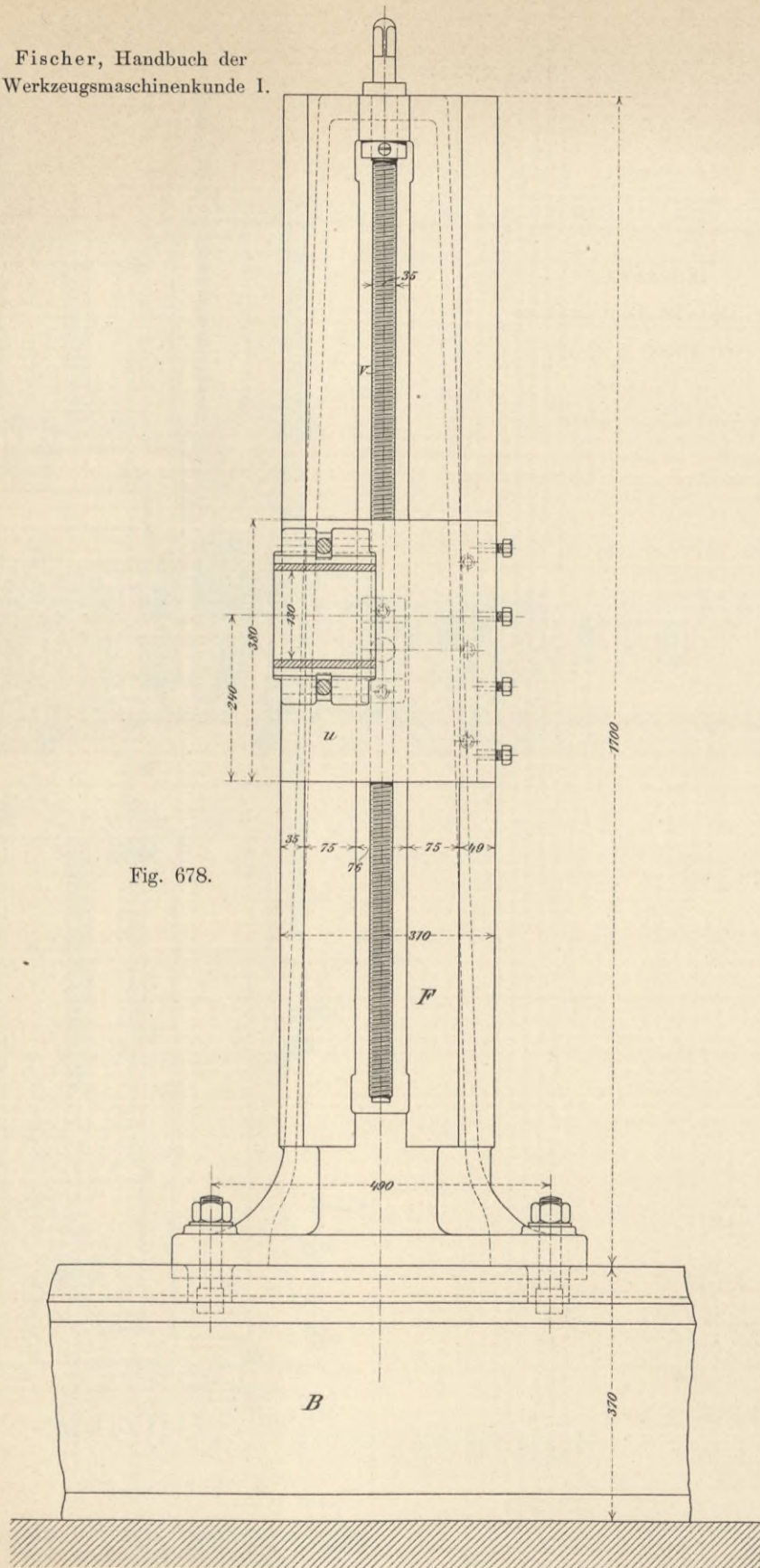

Hilfsständer
zur liegenden Bohrmaschine
von Droop & Rein
in Bielefeld.
1/10 wahrer Grösse.

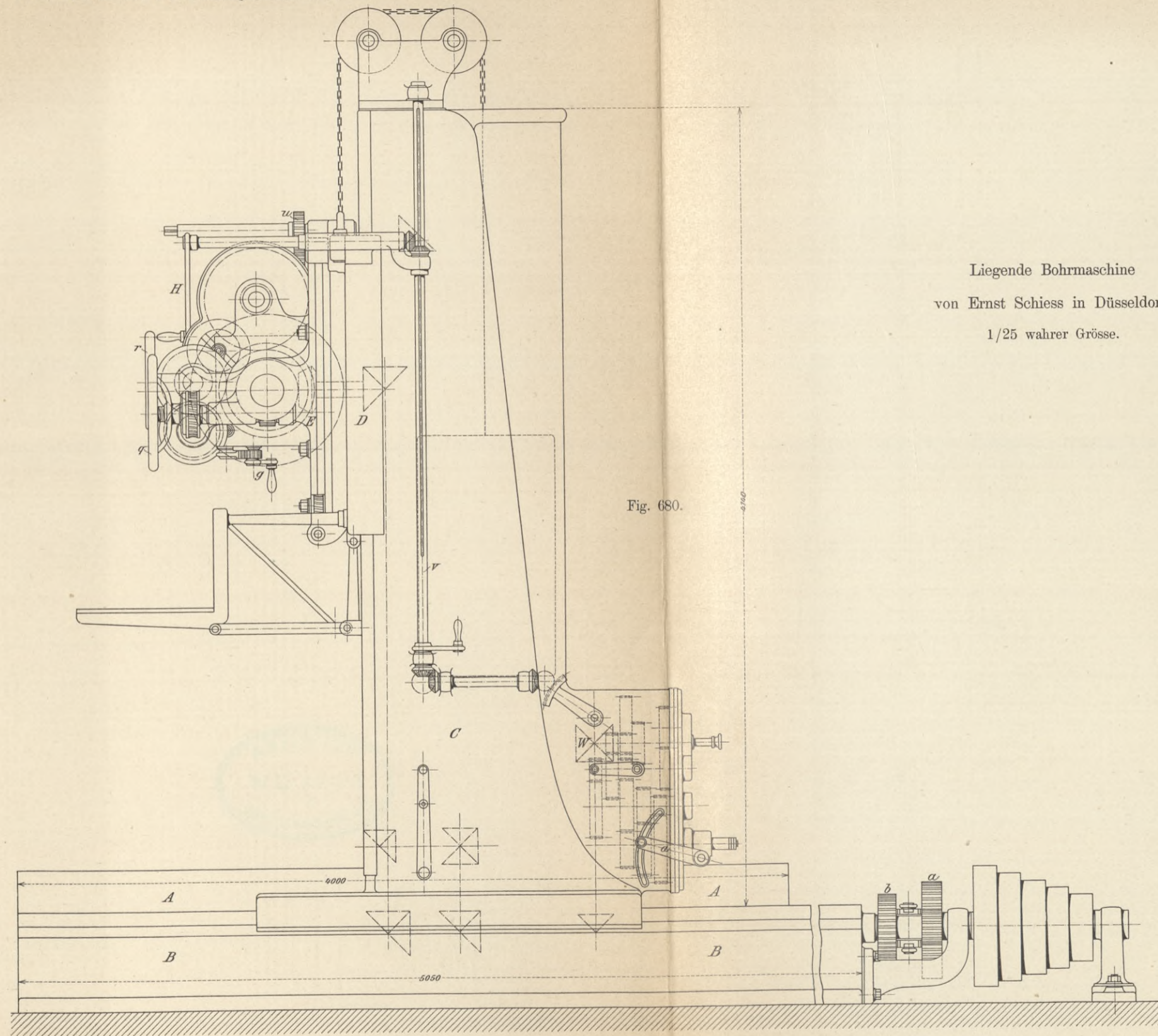

Liegende Bohrmaschine
 von Ernst Schiess in Düsseldorf.
 1/25 wahrer Grösse.

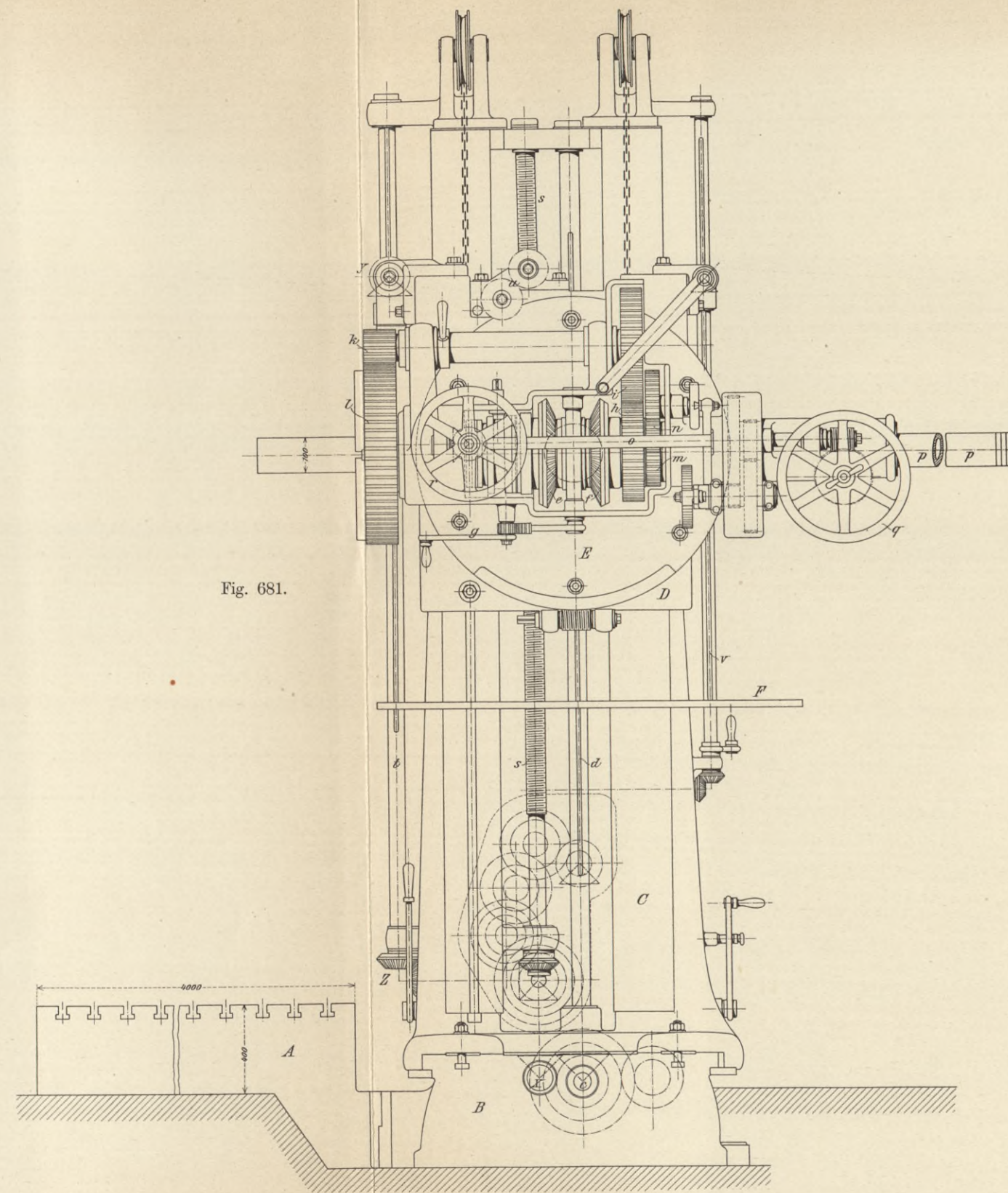



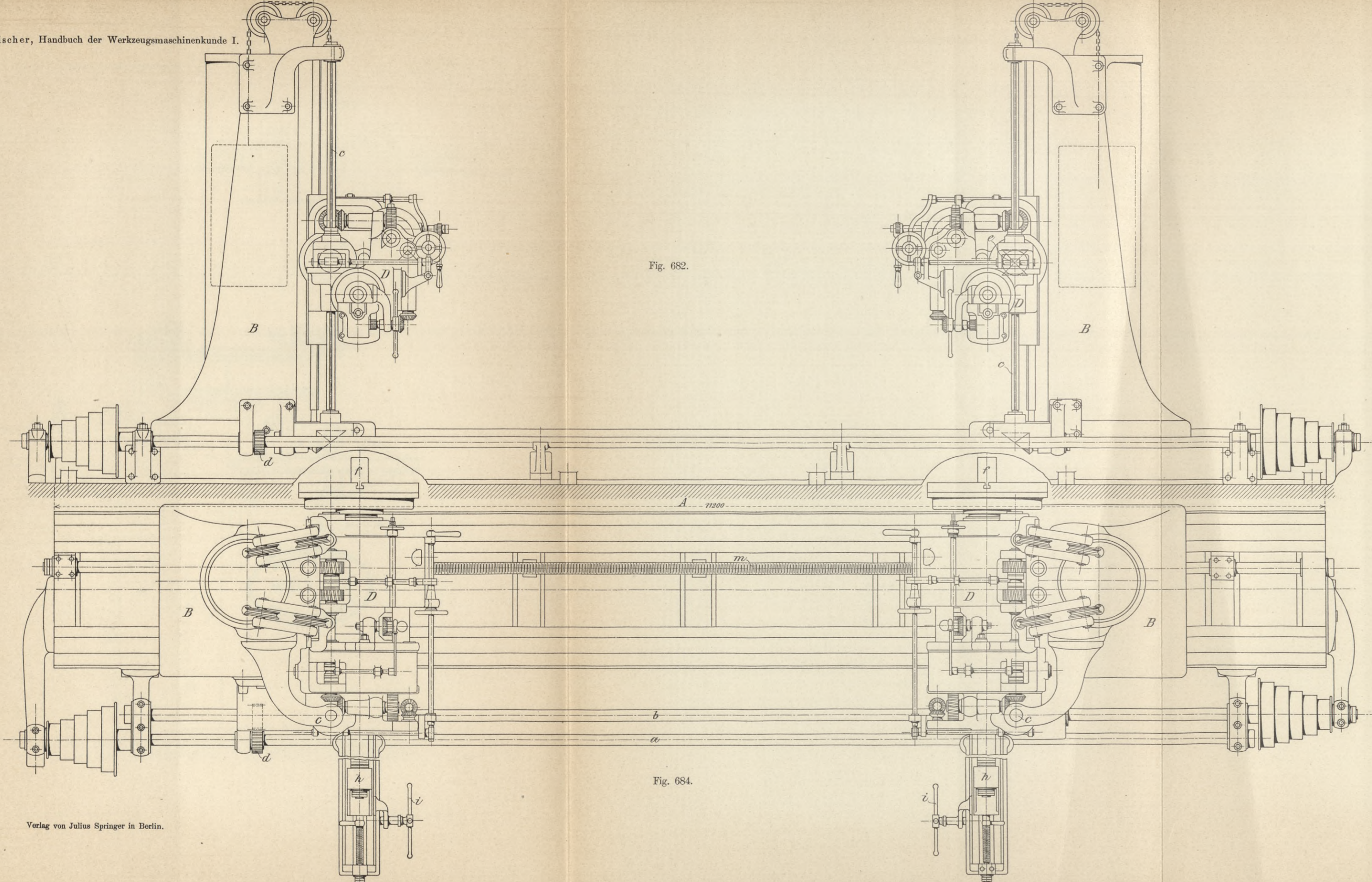

Fig. 682.

Fig. 684.

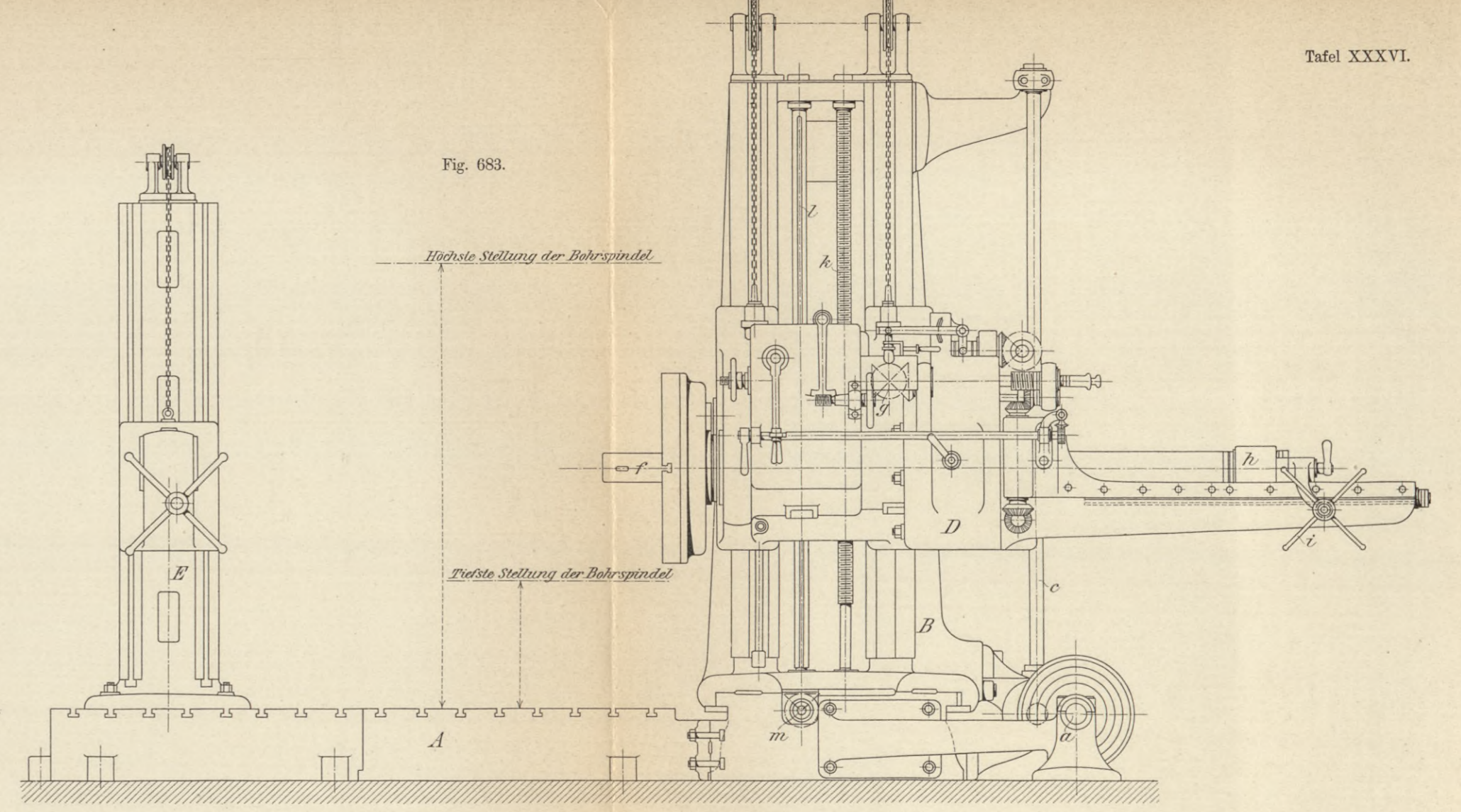

Fig. 683.

Doppelte liegende Bohr- und Fräsmaschine
 von Ernst Schiess in Düsseldorf.
 1/30 wahrer Grösse.



Wurmfräsmaschine
von J. E. Reinecker in Chemnitz.
1/10 wahrer Grösse.

Fig. 798.

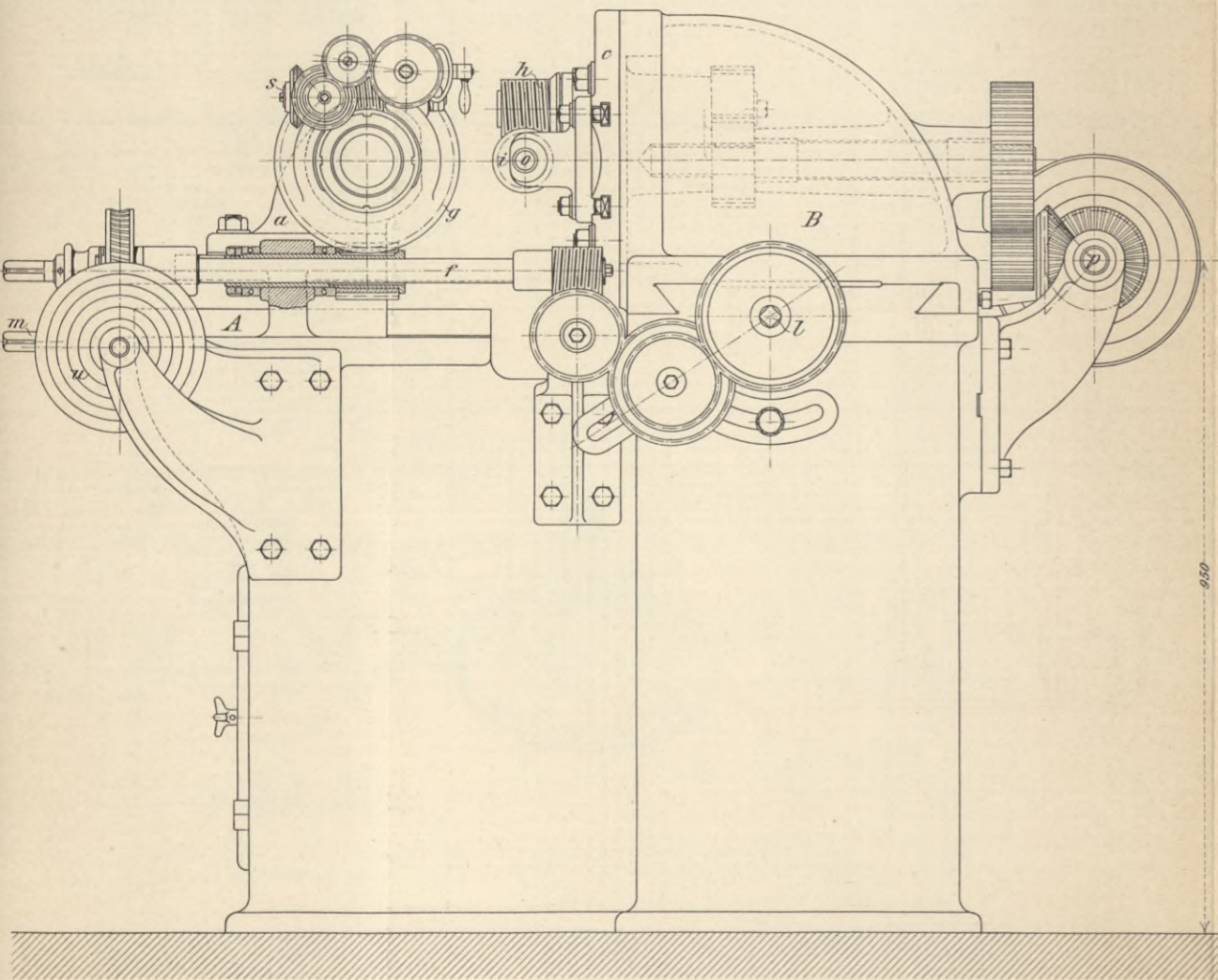

Fig. 800.

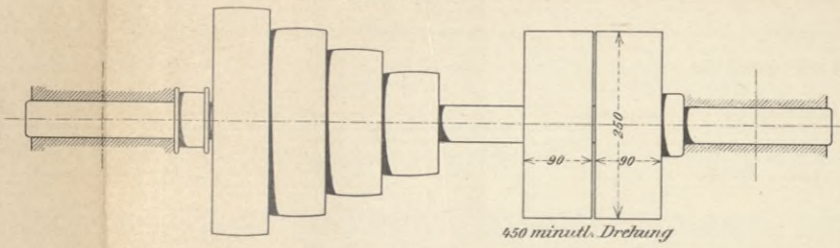

Fig. 801.

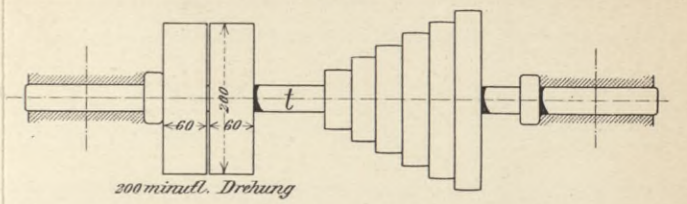
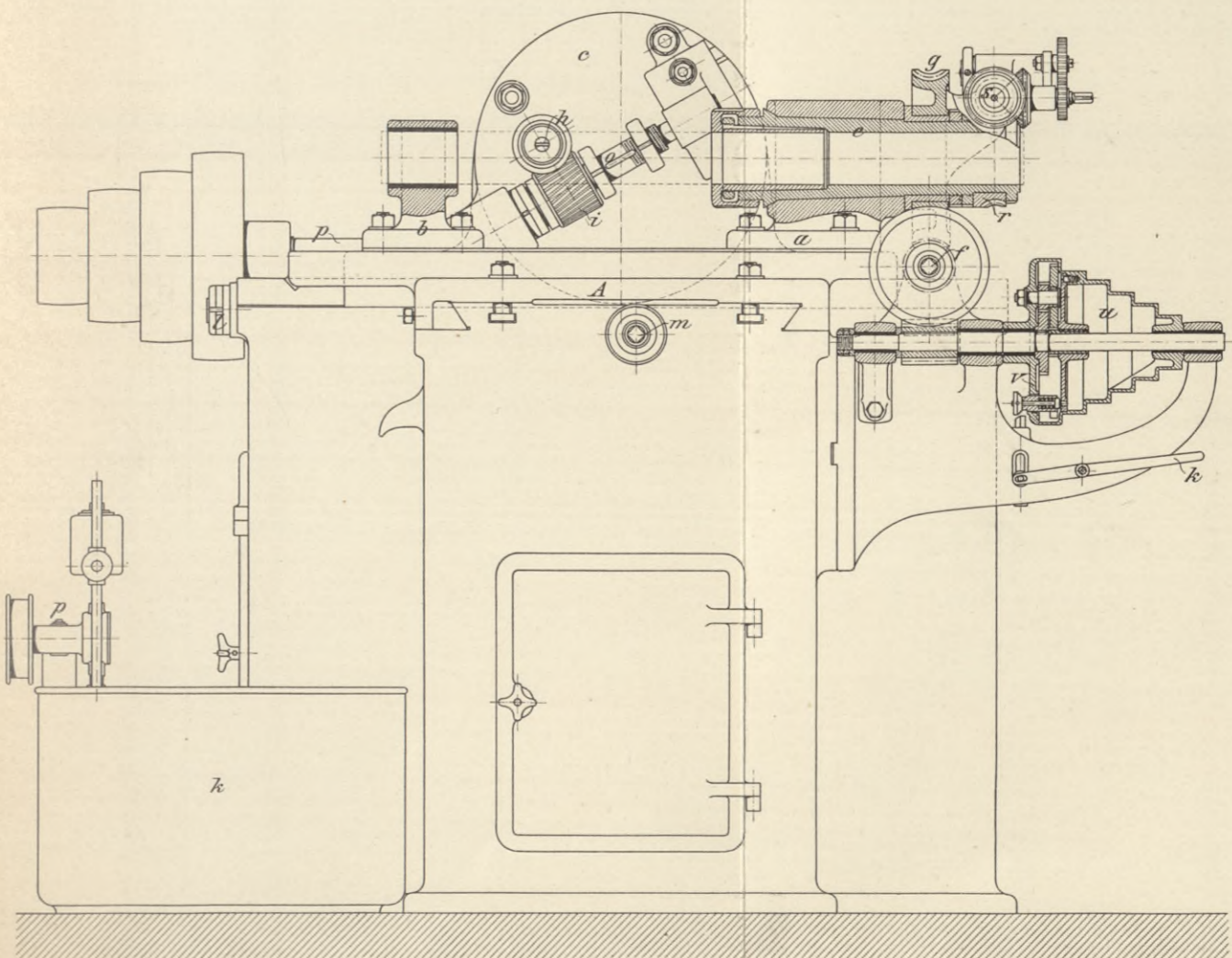

Fig. 799.







Auf Tafel XXXIX sind die
Figurennummern zu ändern:

799	in	815
800	„	816
801	„	817
802	„	818
803	„	819
804	„	820

PLATE XXIX and the
American and British

1891 to 1892

1892 to 1893

1893 to 1894

1894 to 1895

1895 to 1896

1896 to 1897

1897 to 1898

1898 to 1899

1899 to 1900

1900 to 1901

1901 to 1902

1902 to 1903

1903 to 1904

1904 to 1905

1905 to 1906

1906 to 1907

1907 to 1908

1908 to 1909

1909 to 1910

Langfräsmaschine
von J. E. Reinecker in Chemnitz.
1/10 wahrer Grösse.

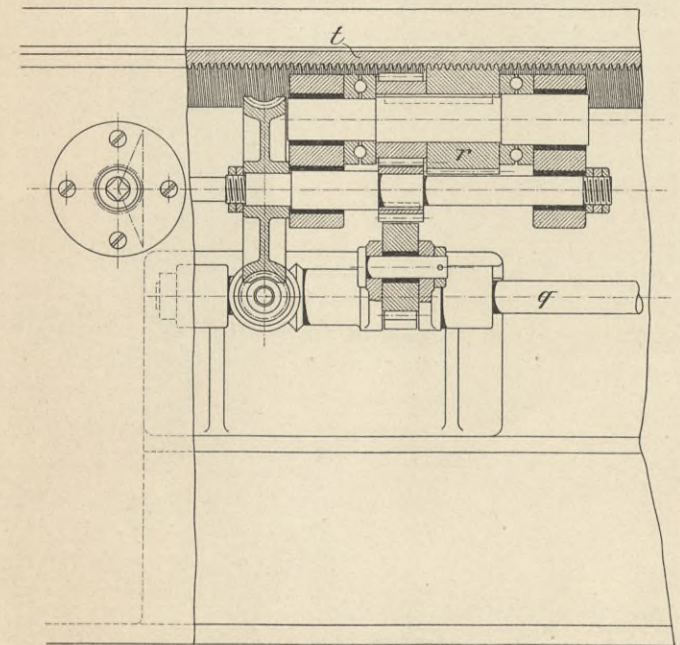
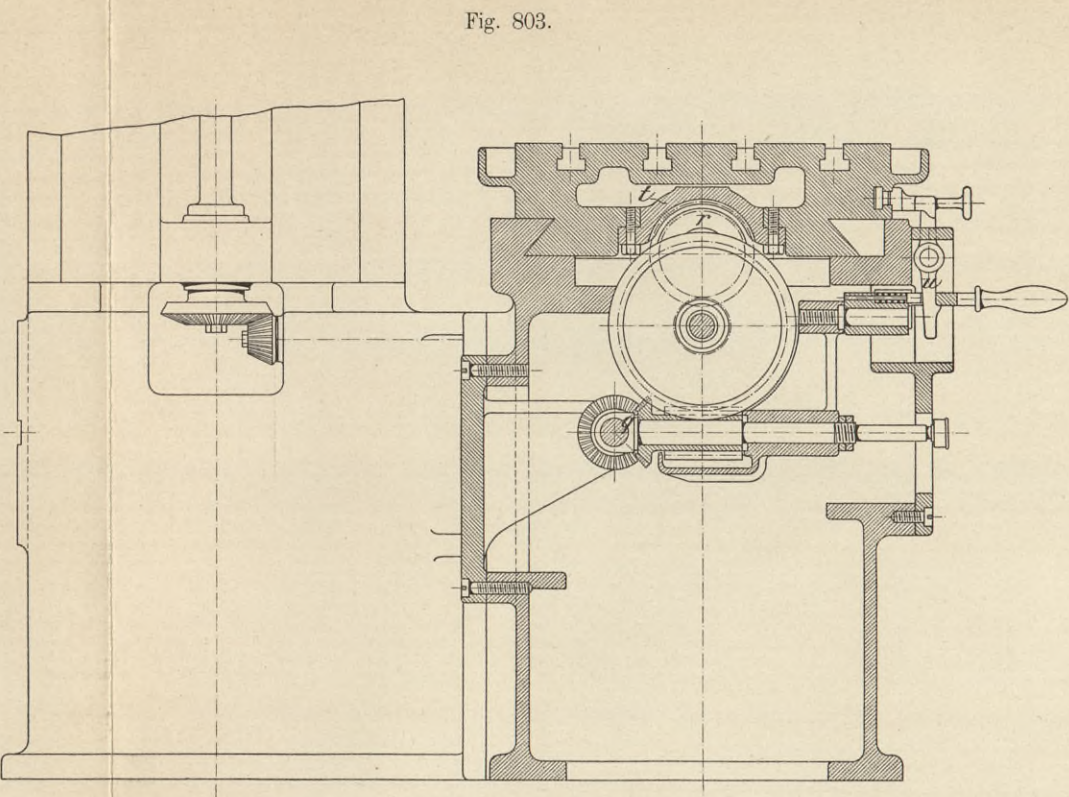
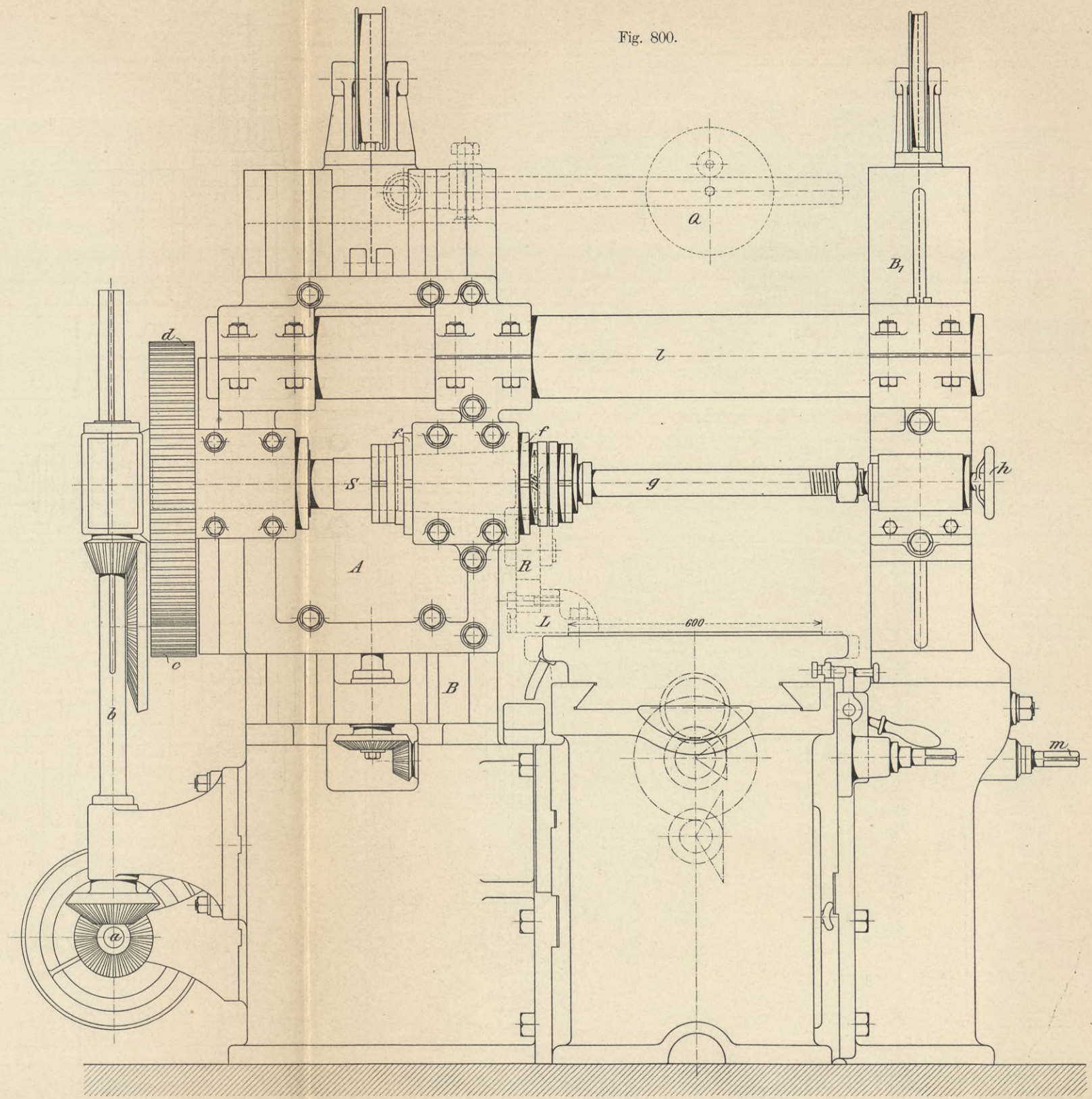
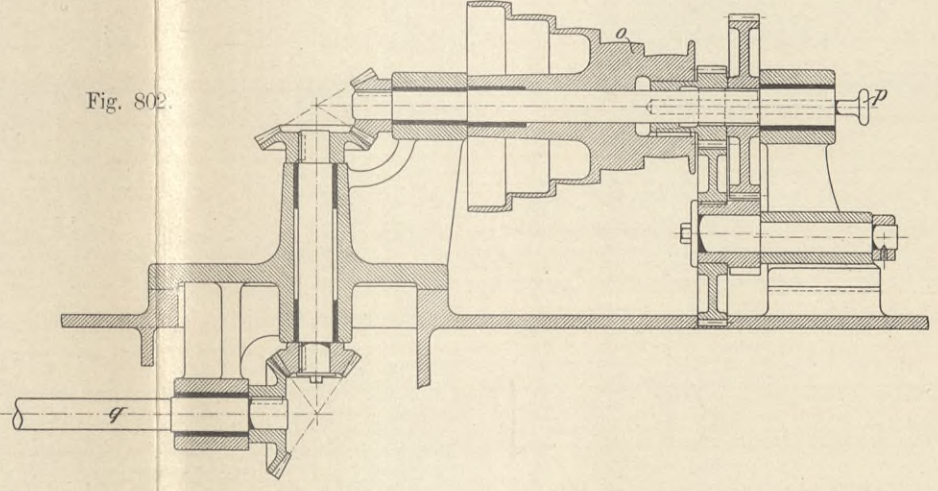
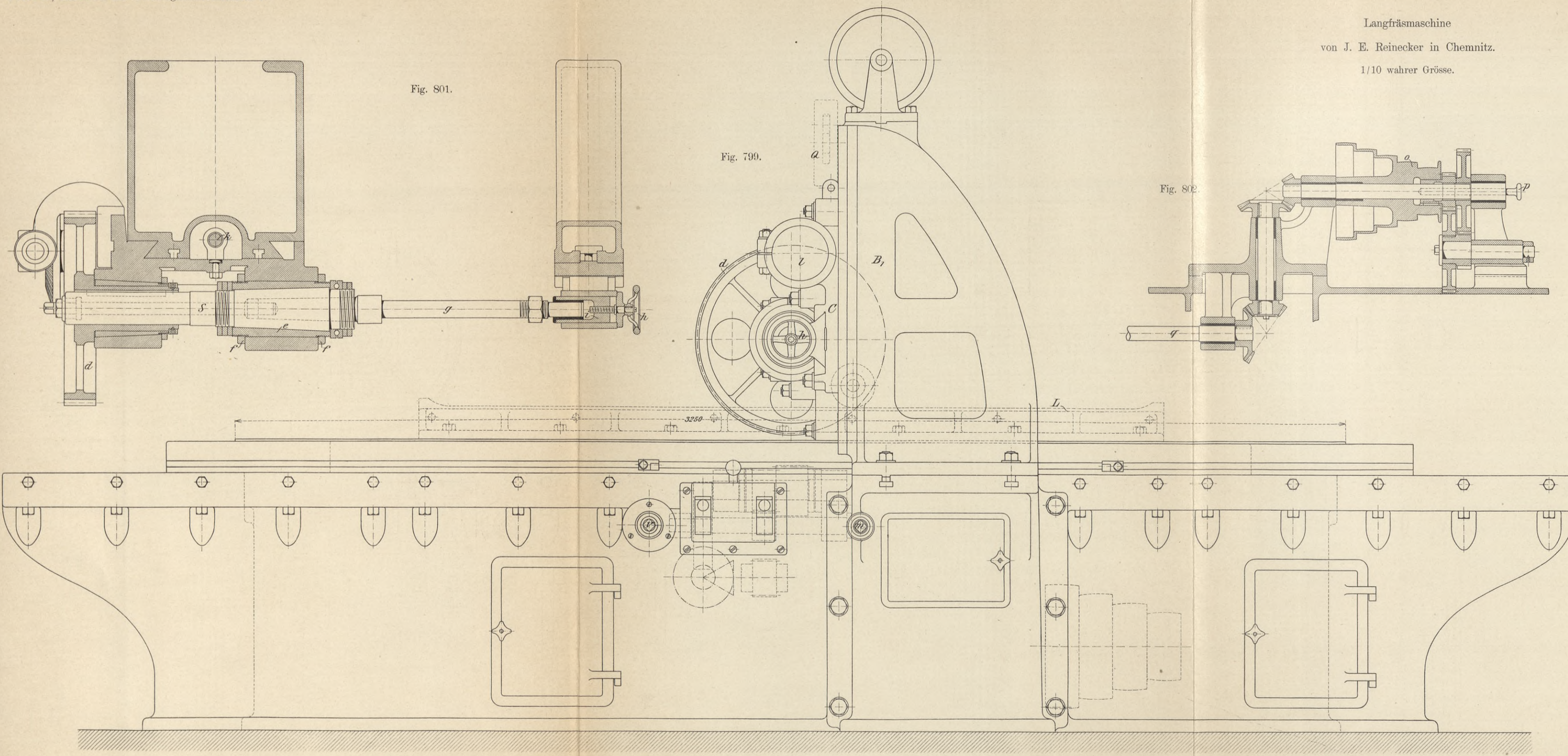



Langlochfräsmaschine
von Droop & Rein in Bielefeld.

Fig. 824.

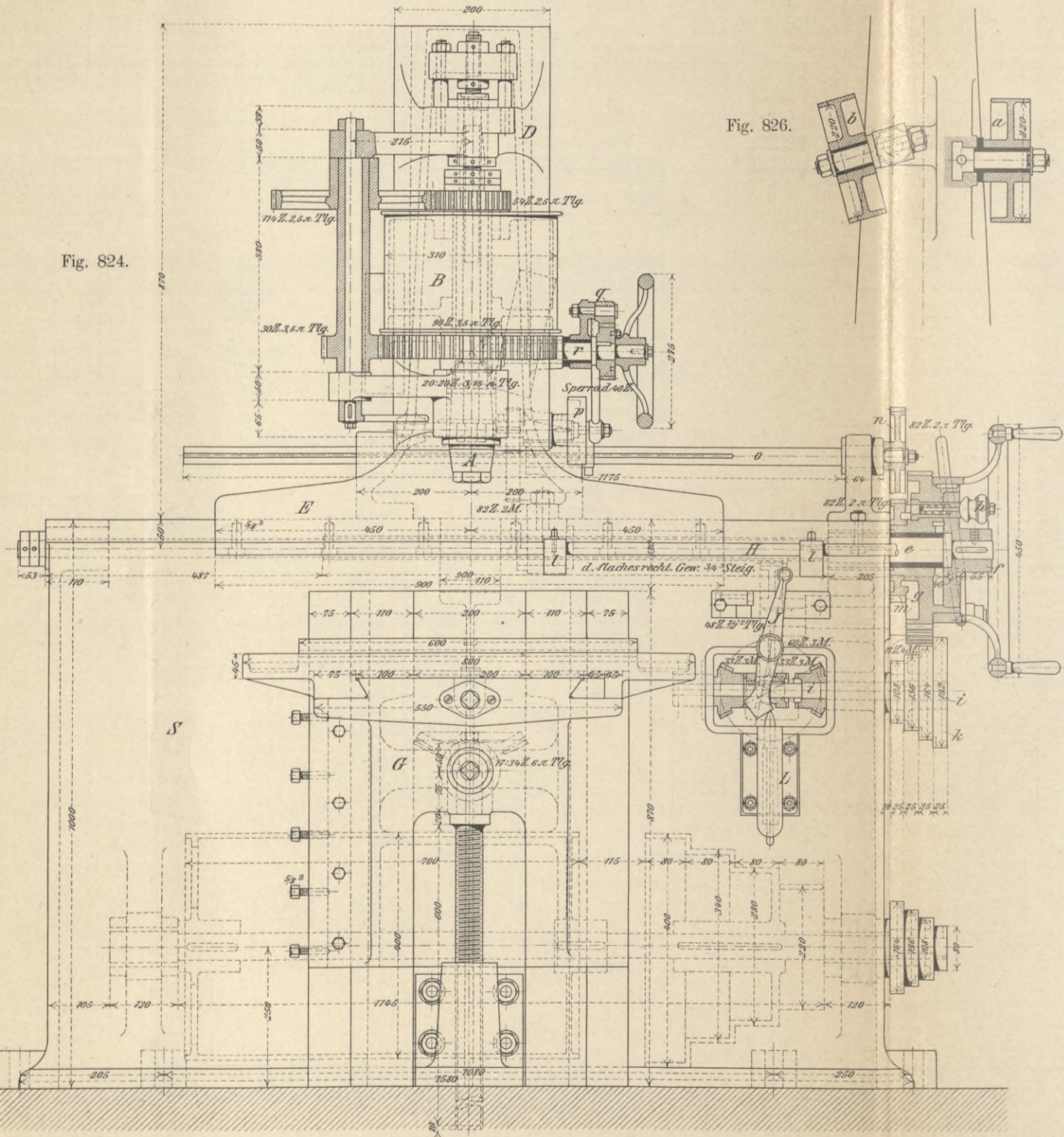

Fig. 826.

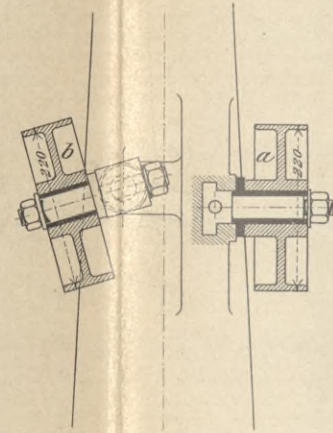

Fig. 825.

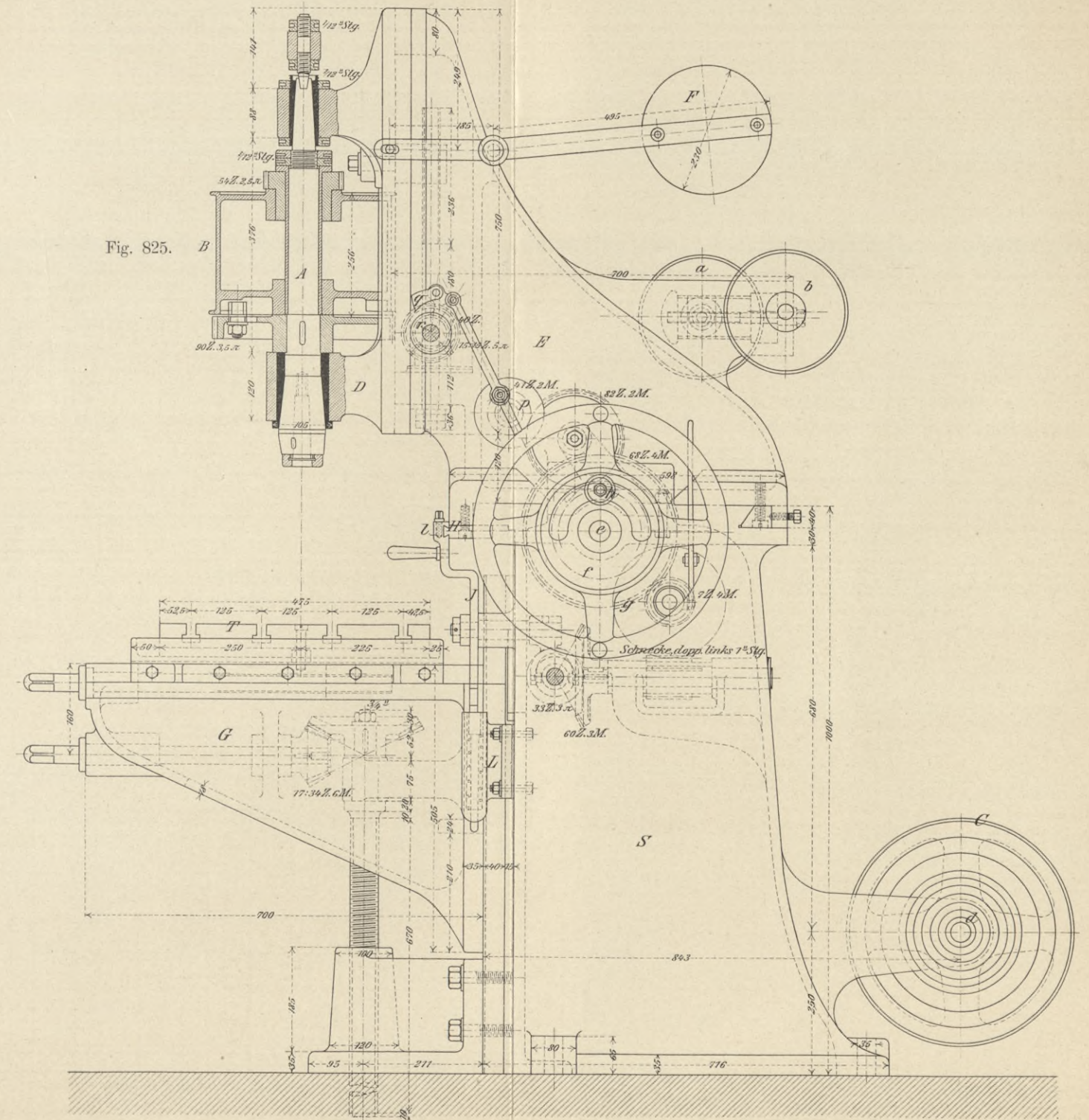
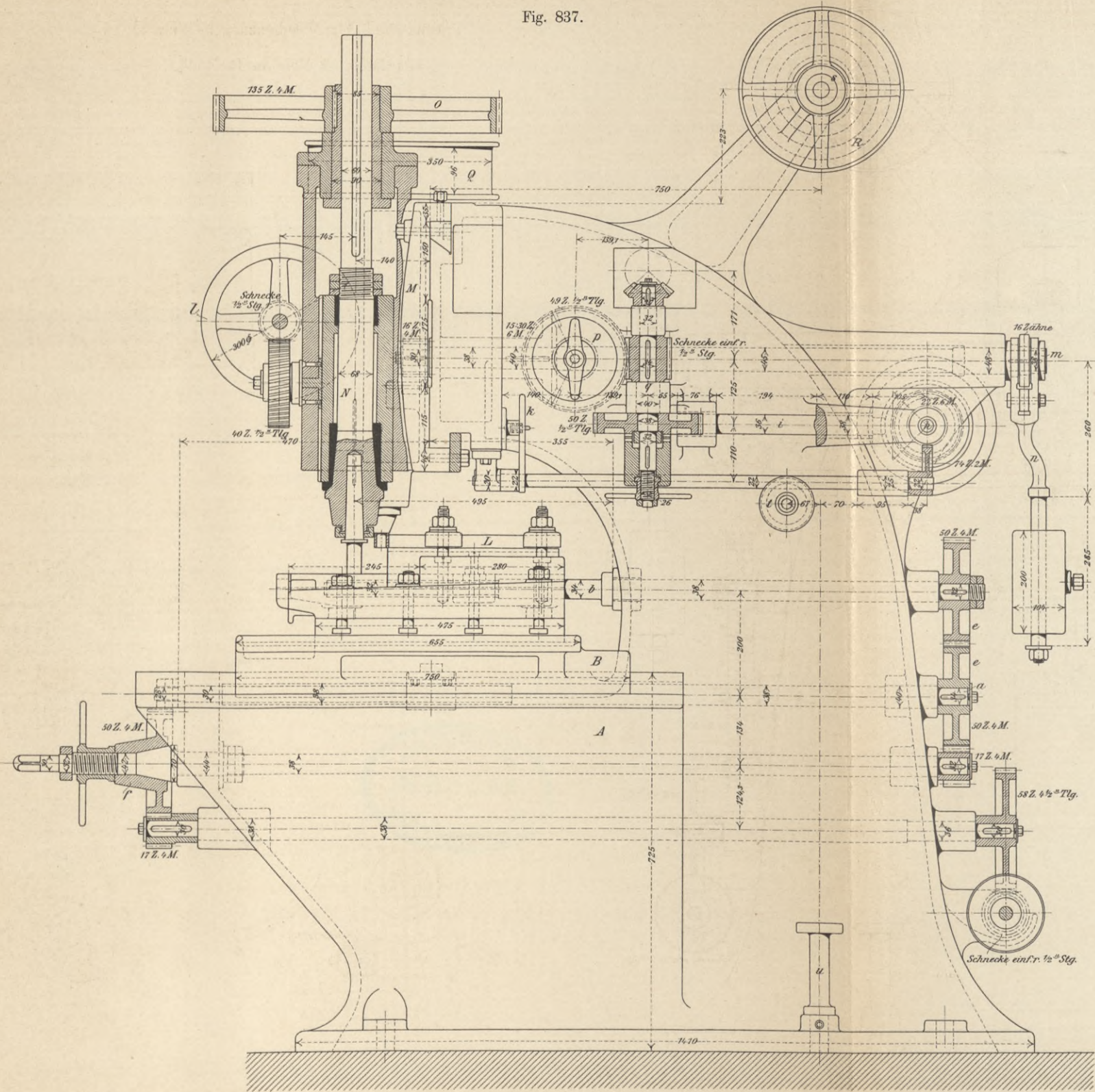



Fig. 837.



Fräsmaschine für Weichzungen-Wurzeln
von Droop & Rein in Bielefeld.

Fig. 839.

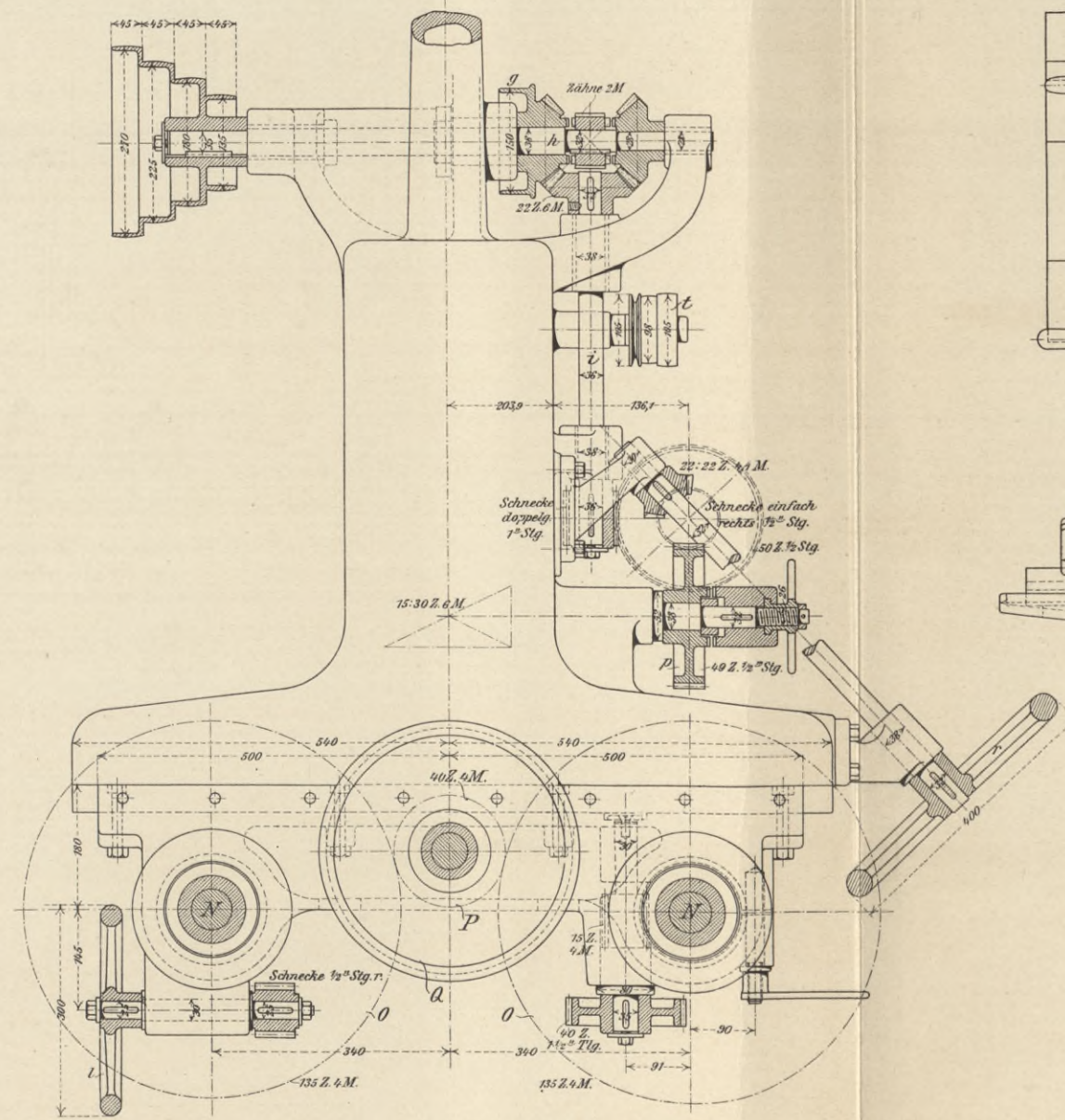
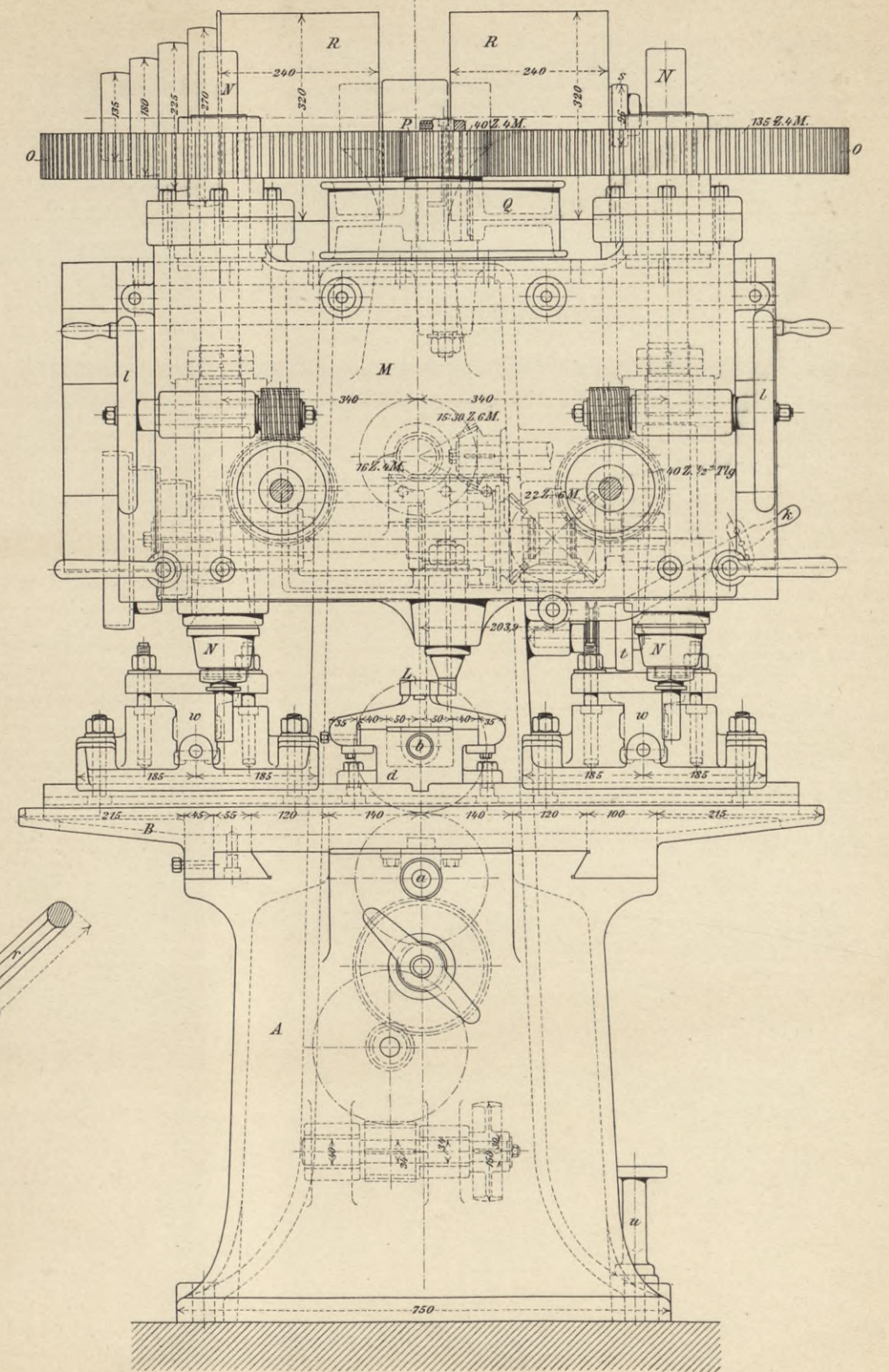

Fig. 838.





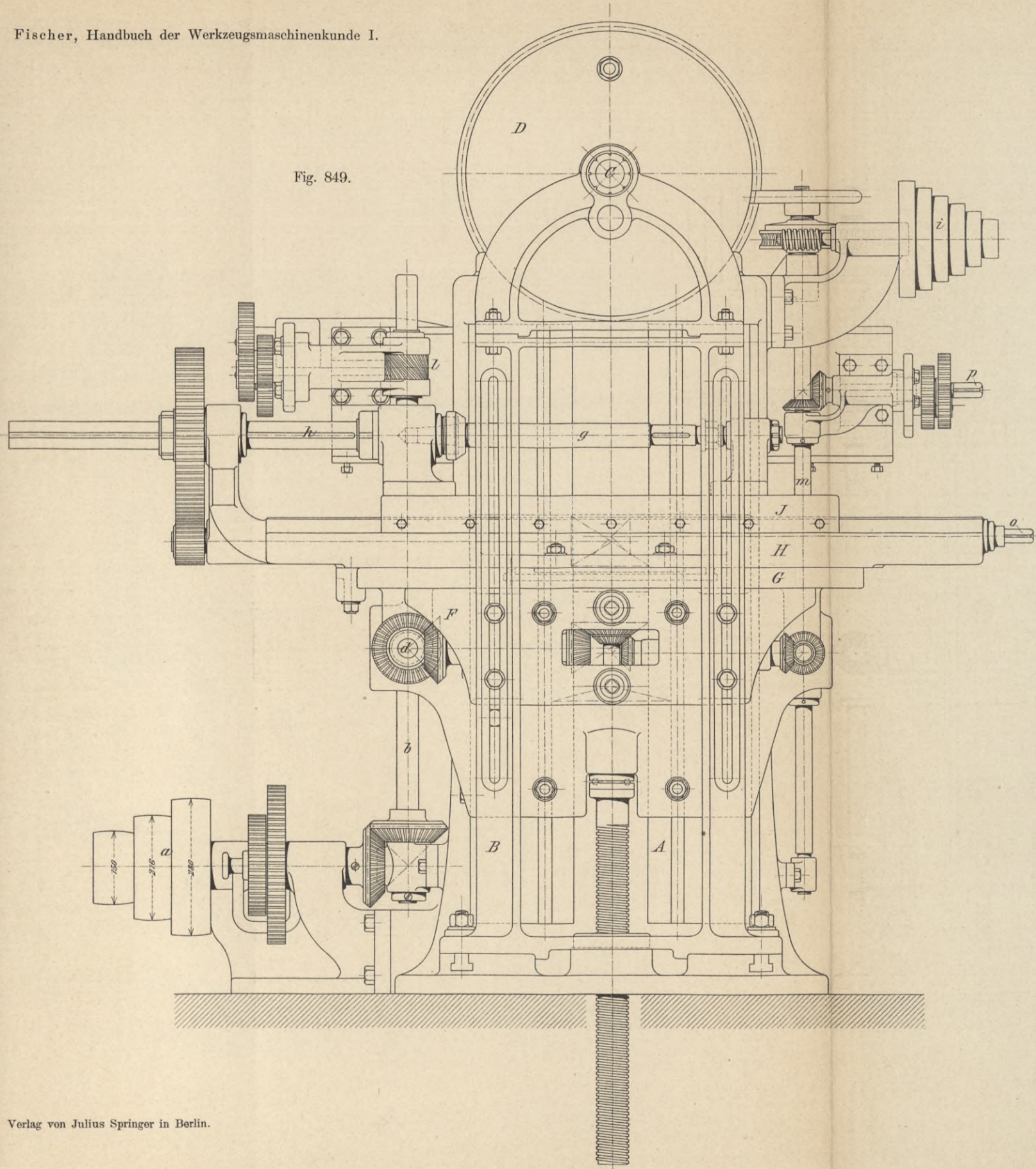

Fig. 849.

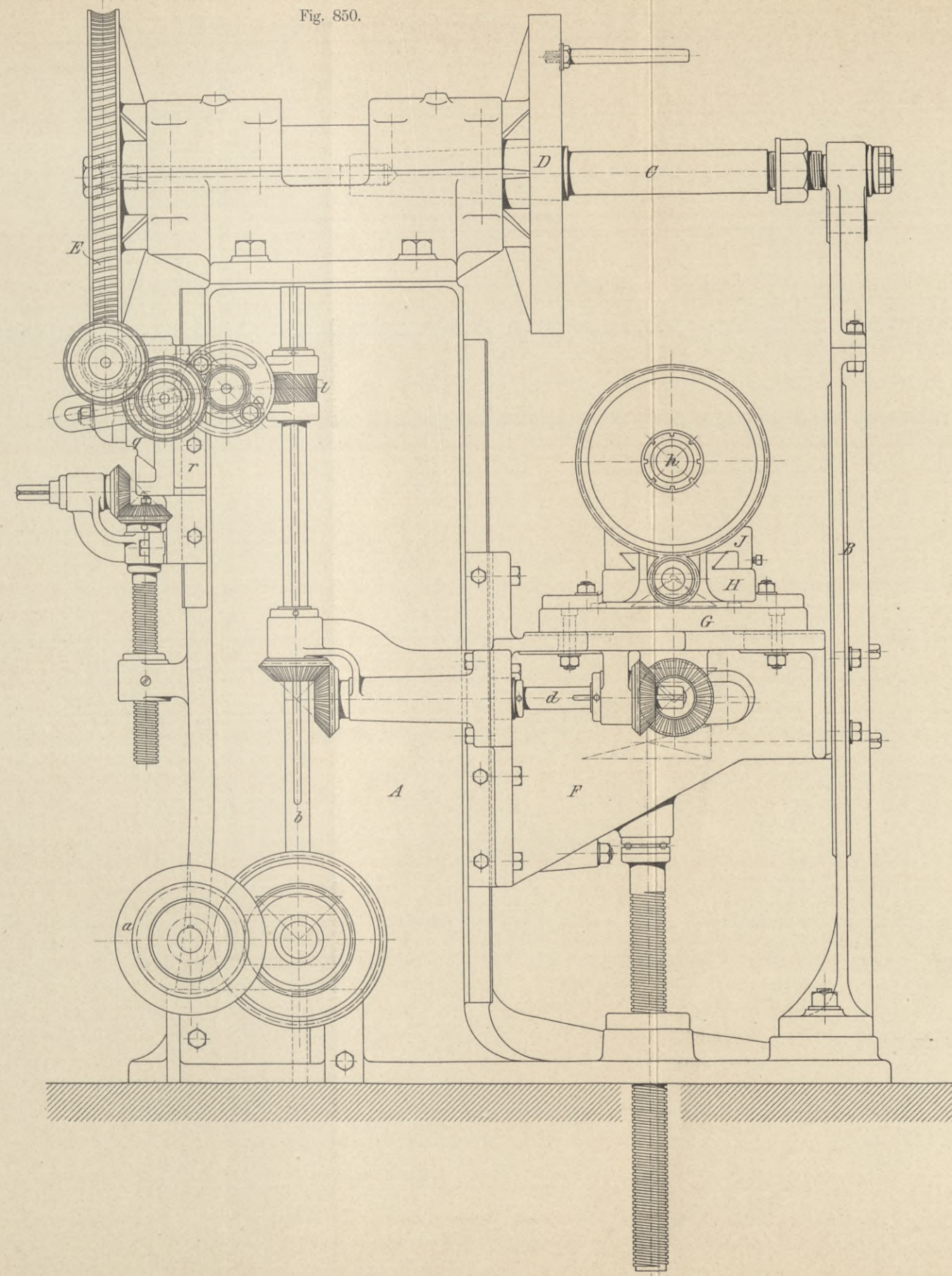

Fig. 850.

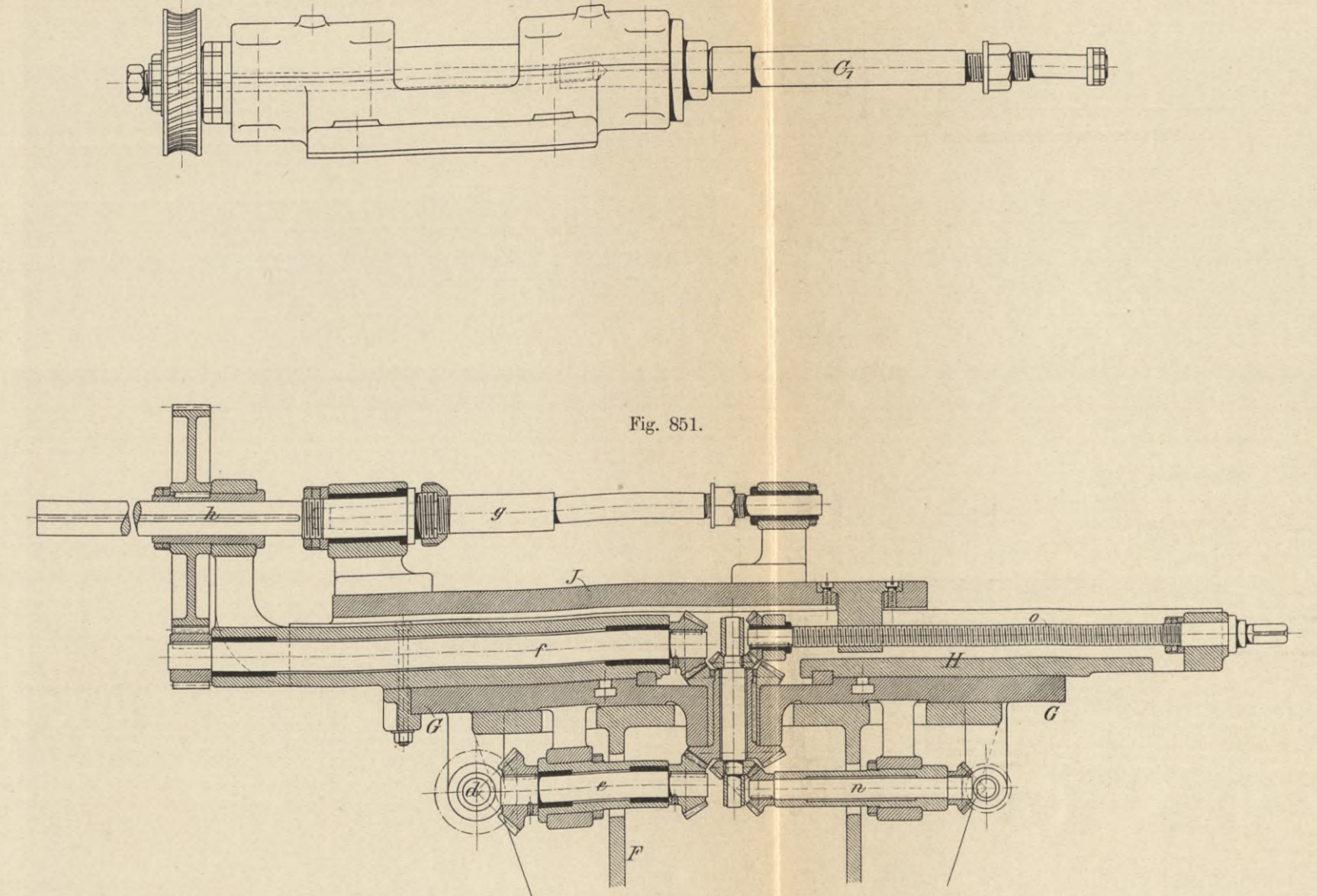

Fig. 852.

Fig. 851.

Wurmfräsmaschine
von J. E. Reinecker in Chemnitz.
1/10 wahrer Grösse.



Bleischere von Otto Froriep in Rheydt.

1/30 wahrer Grösse.

Fig. 986.

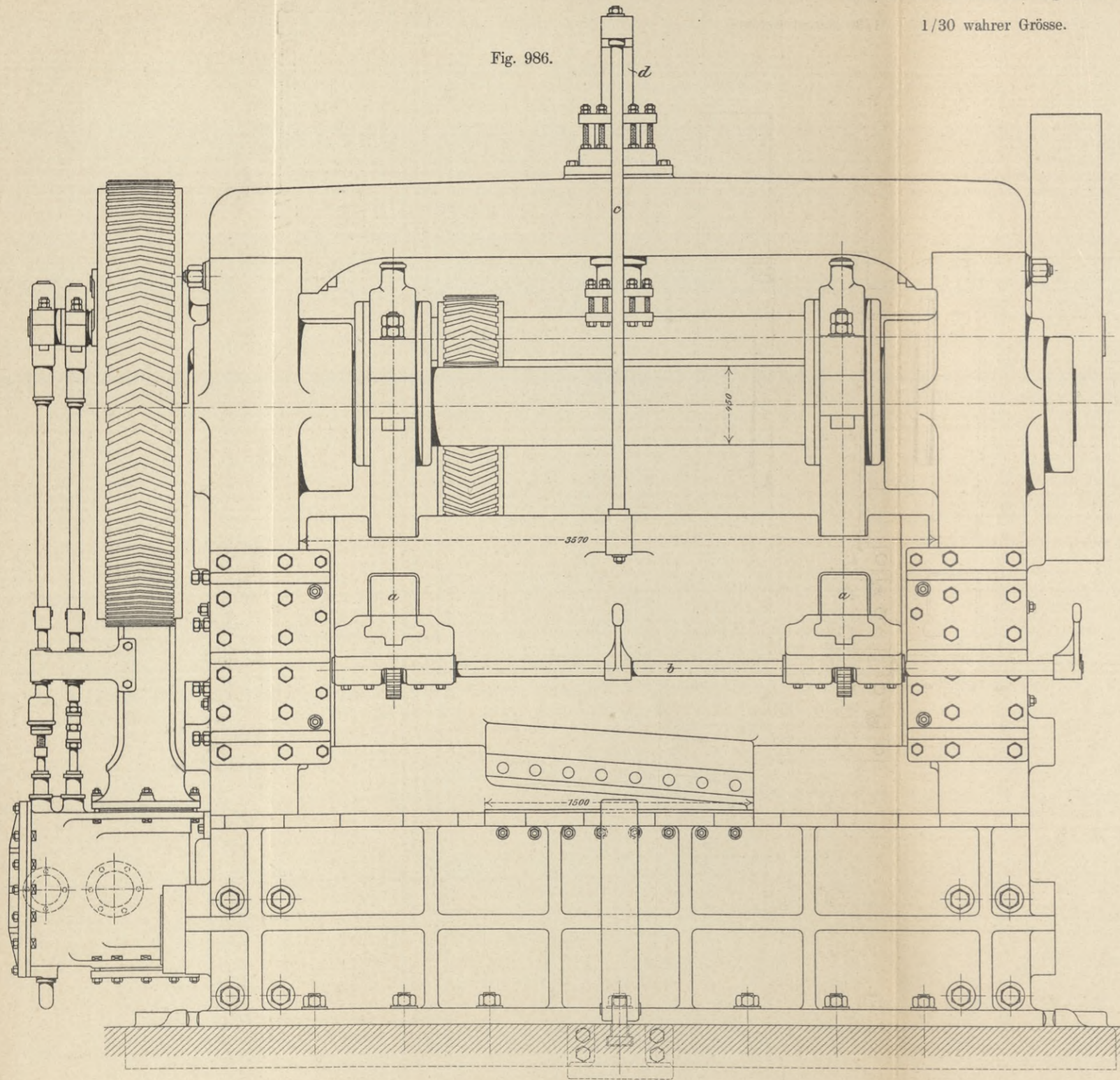

Fig. 985.

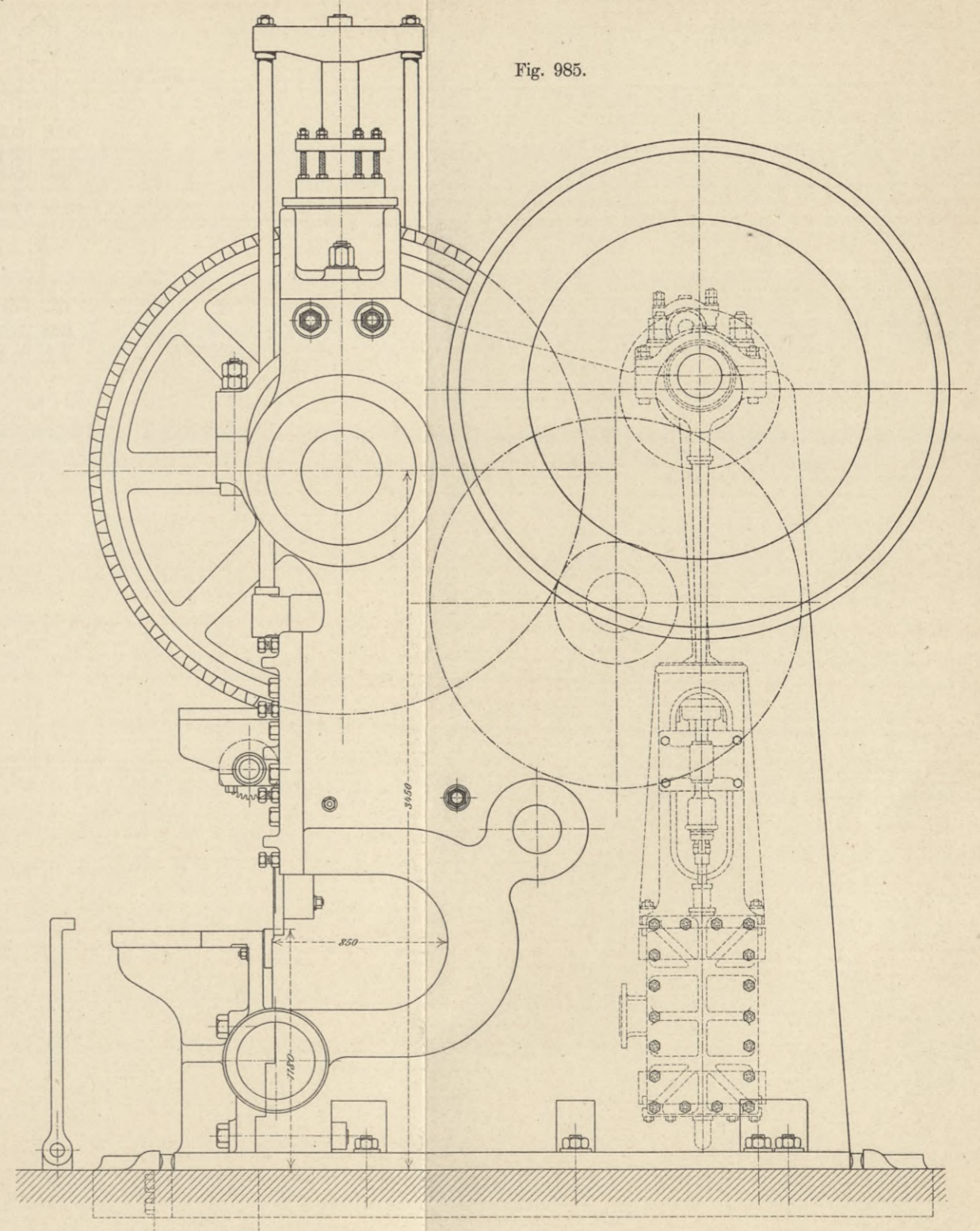
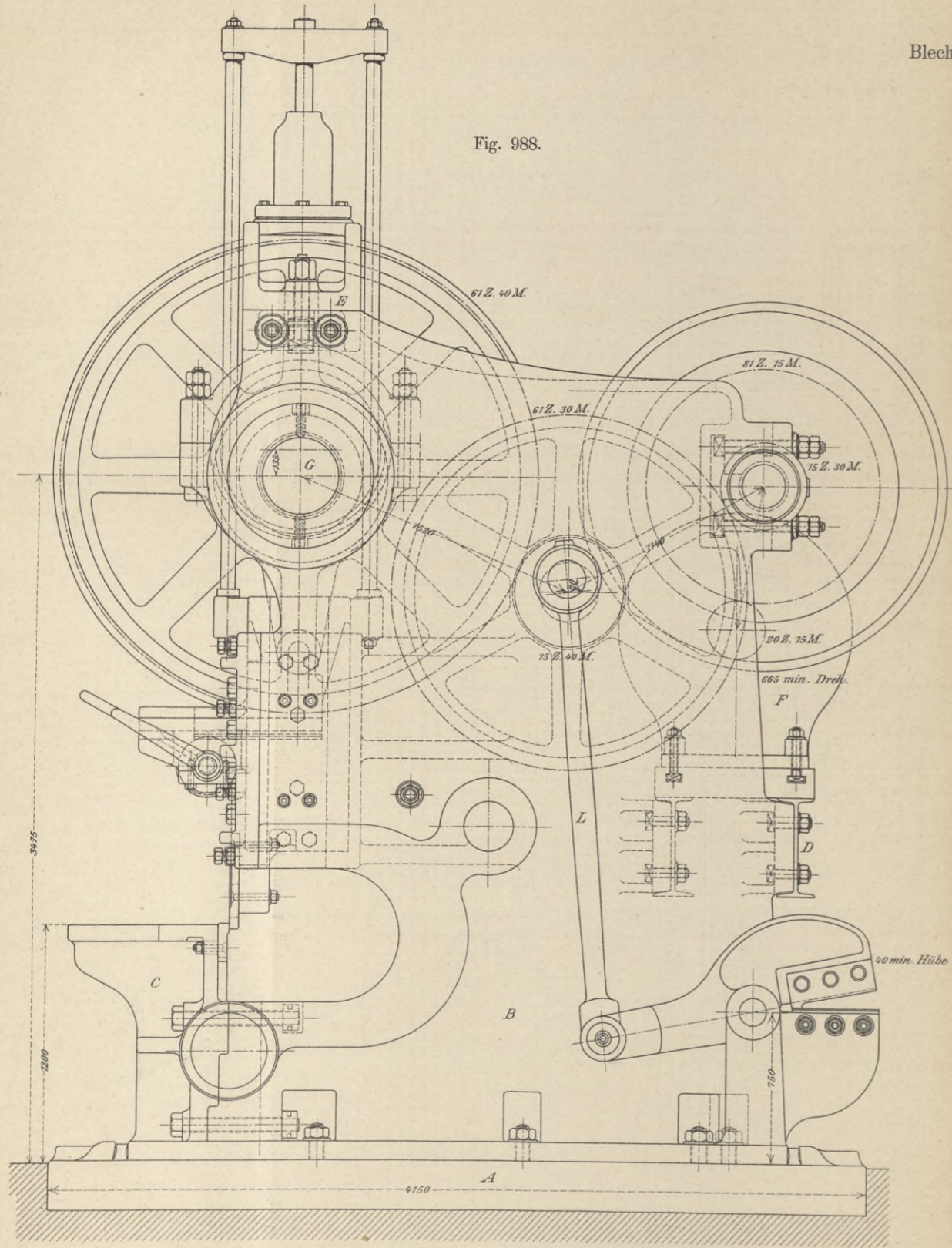



Fig. 988.



Blechscherer von Otto Frozier in Rheydt.

1/30 wahrer Grösse.

Fig. 989.

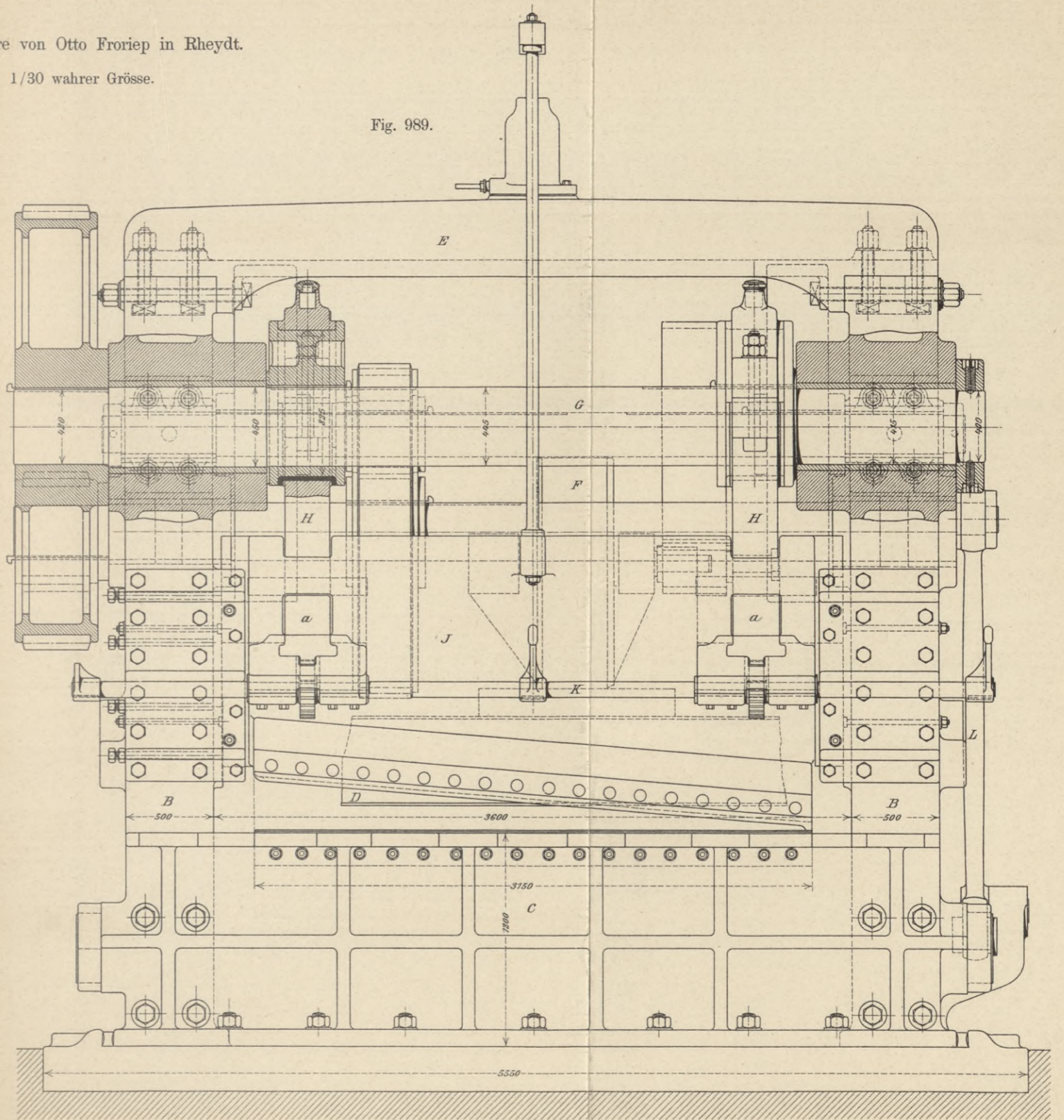

BIBLIOTEKA
KRAKÓW
Politechniczna

S. 61

5900

BIBLIOTEKA
KRAKÓW
Politechniczna

WYDZIAŁY POLITECHNICZNE KRAKÓW

Biblioteka Politechniki Krakowskiej



III-306956

Druk. U. J. Zam. 356. 10.000.

Biblioteka Politechniki Krakowskiej



100000300230