

Biblioteka Politechniki Krakowskiej



100000300266



Franz Franke.

DIE
MASCHINEN-ELEMENTE.

IHRE
BERECHNUNG UND KONSTRUKTION
MIT RÜCKSICHT AUF DIE NEUEREN VERSUCHE.

VON
C. Bach,
BAUDIREKTÖR,
PROFESSOR DES MASCHINEN-INGENIEURWESENS AN DER K. TECHNISCHEN HOCHSCHULE STUTTGART.

FÜNFTE, VERMEHRTE AUFLAGE.

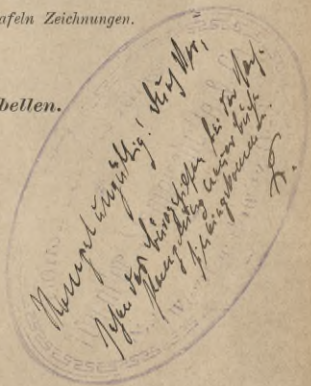
In zwei Bänden.

Mit in den Text gedruckten Abbildungen und 53 Tafeln Zeichnungen.

Zweiter Band: Tafeln und Tabellen.



STUTTGART 1896.
VERLAG DER J. G. COTTASCHEN BUCHHANDLUNG
NACHFOLGER.



508/2



III-306836

*Der Verfasser behält sich das Recht der Herausgabe
in fremden Sprachen vor.*



~~III 16350~~

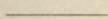
BPK-3 127/2018

Druck der Union Deutsche Verlagsgesellschaft in Stuttgart.

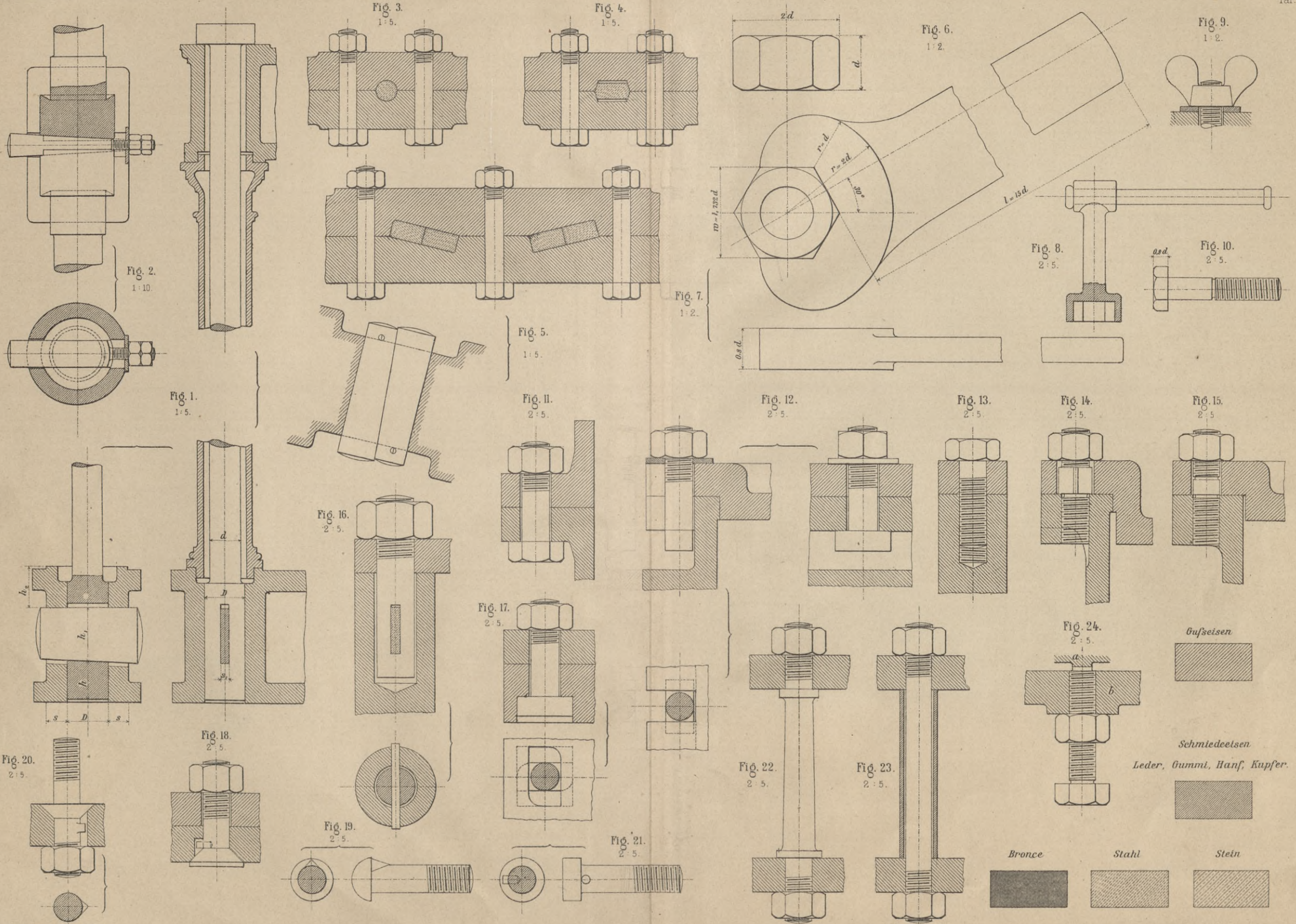
Am... ..

~~16350~~

T a f e l n.

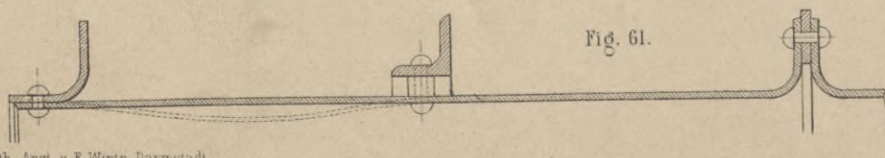
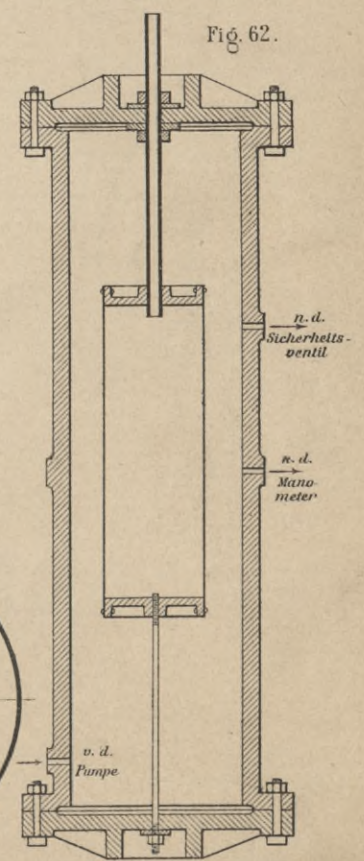
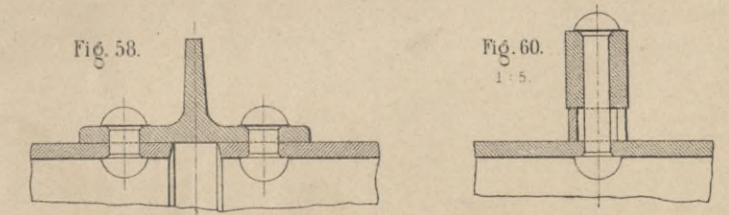
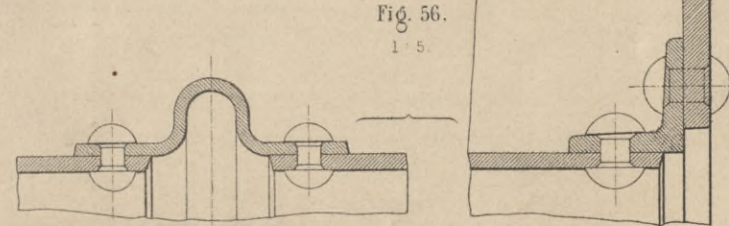
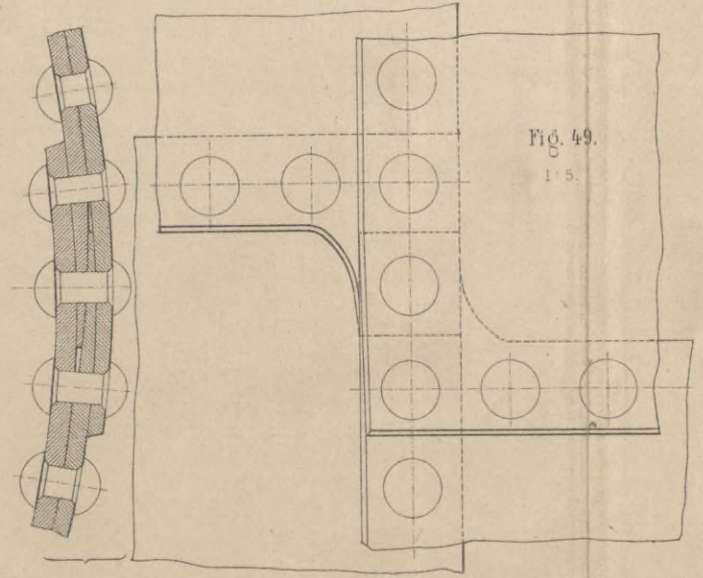
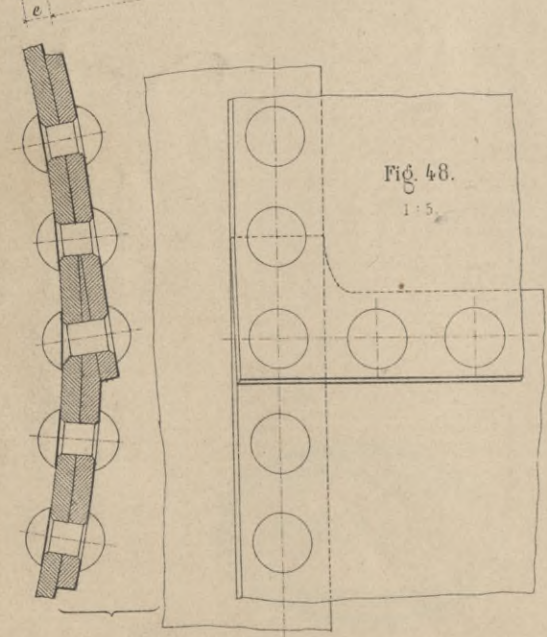
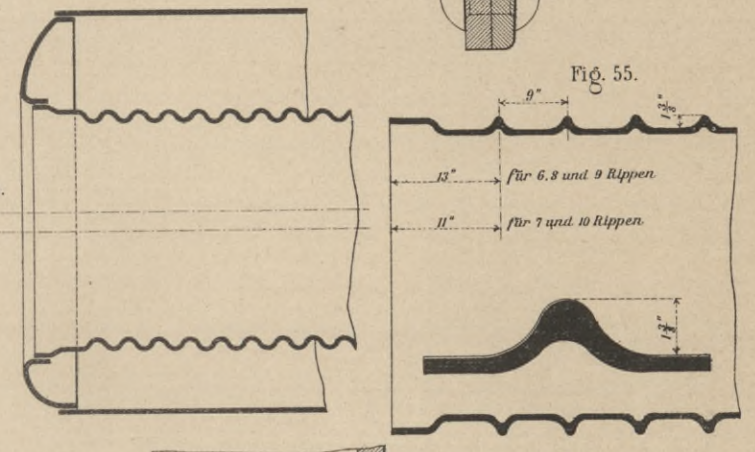
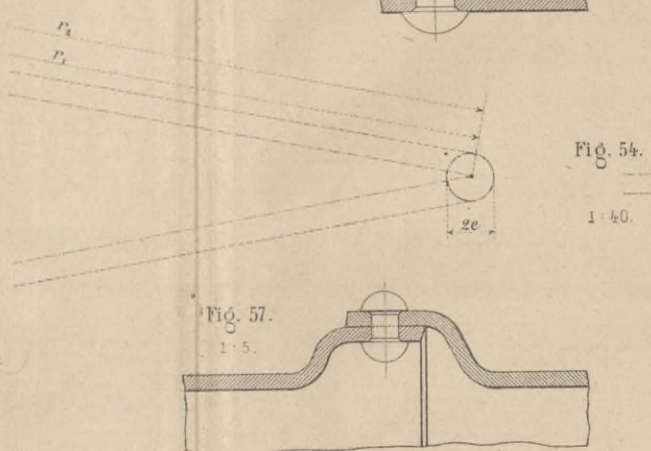
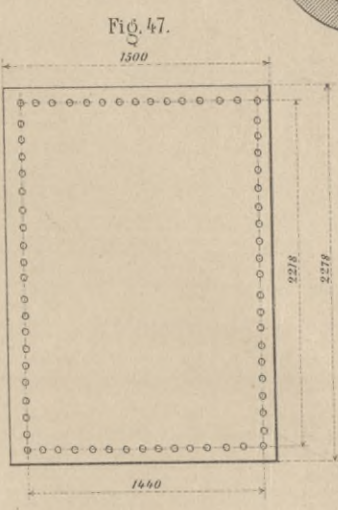
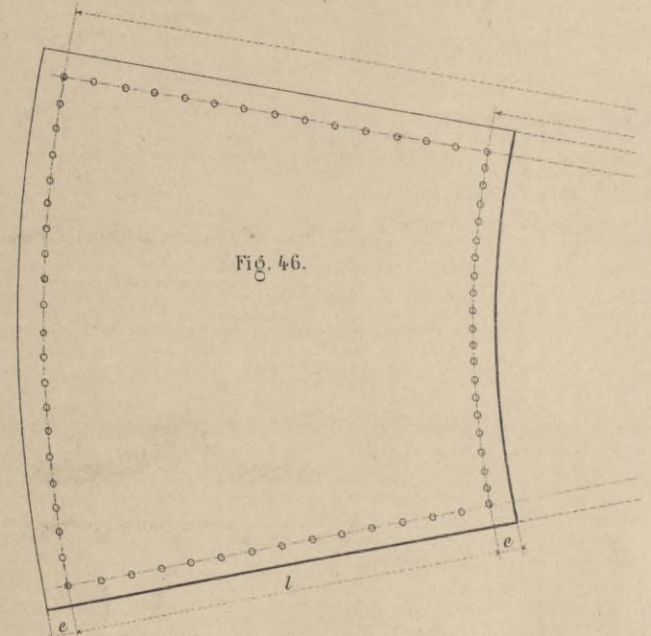
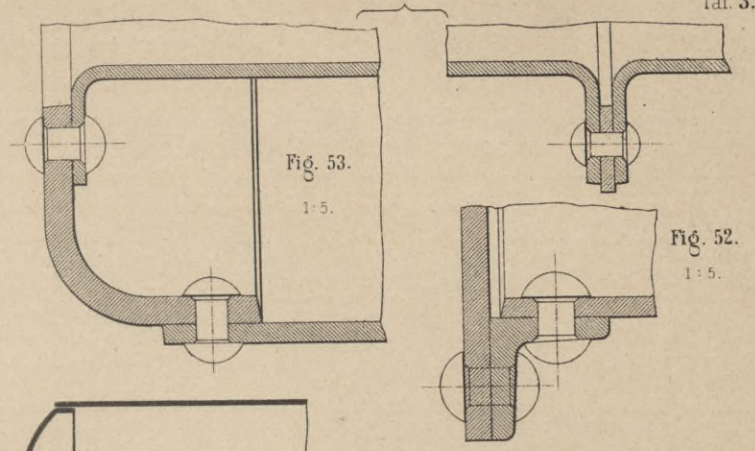
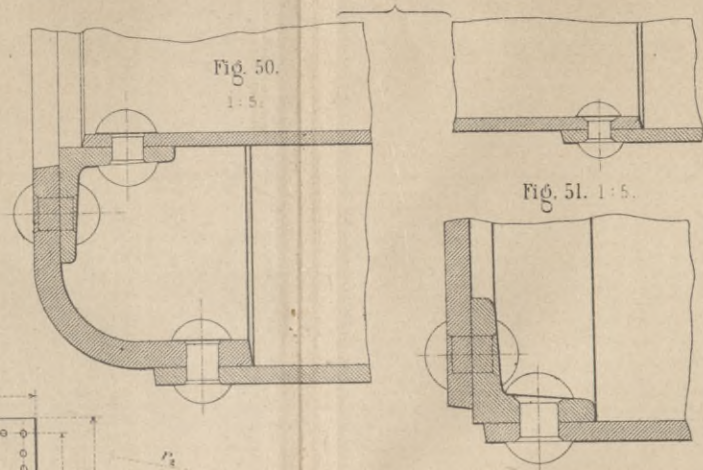
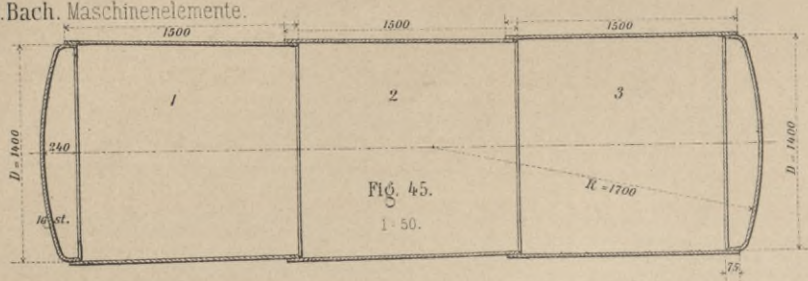












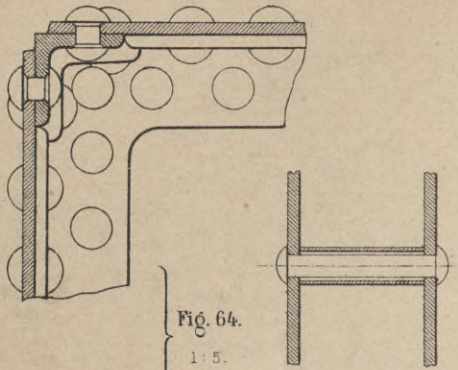


Fig. 66. 1:5.

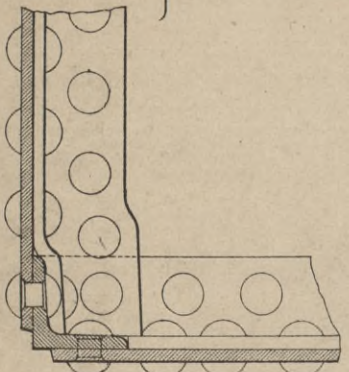
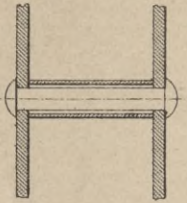


Fig. 65. 1:5.

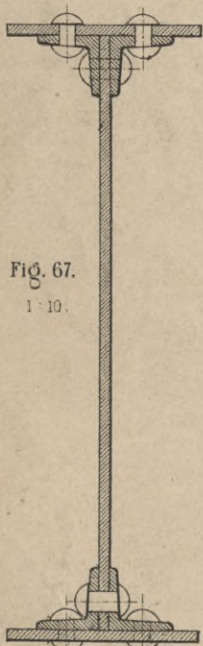
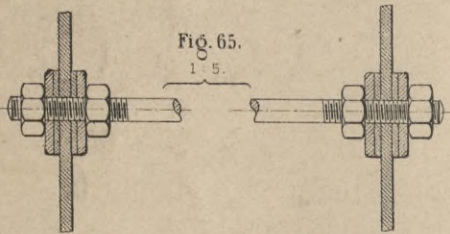


Fig. 67. 1:10.

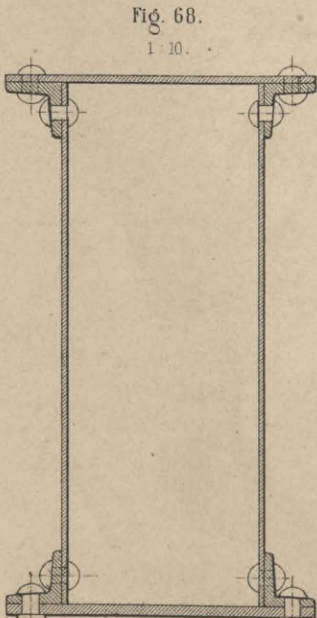


Fig. 68. 1:10.

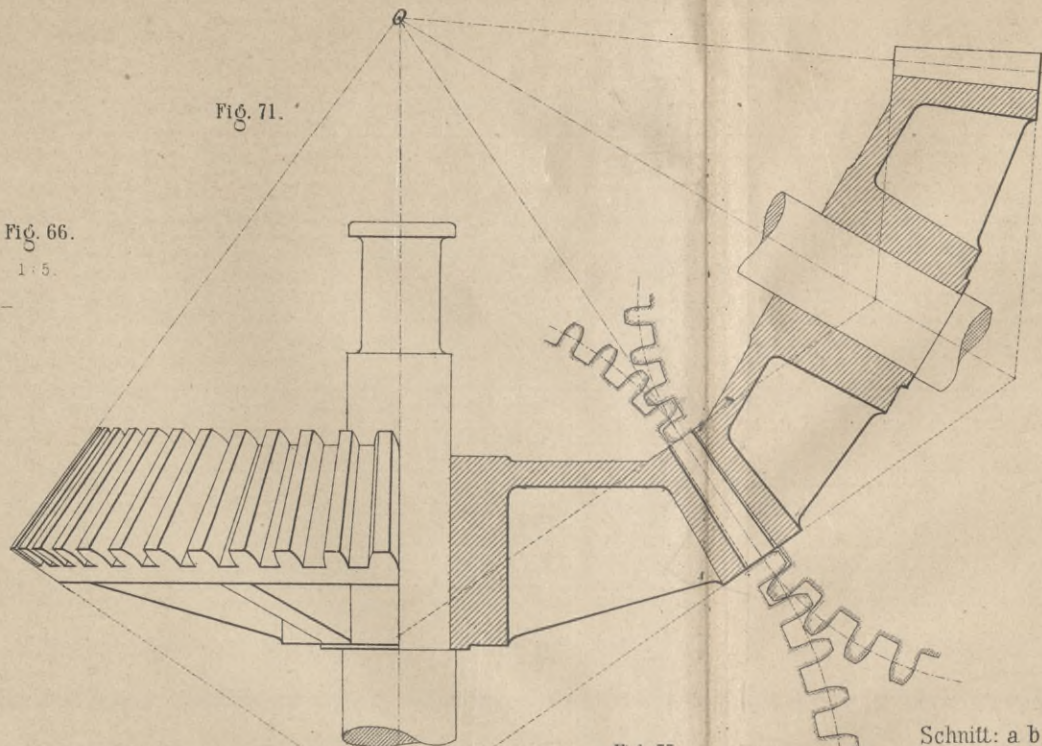


Fig. 71.

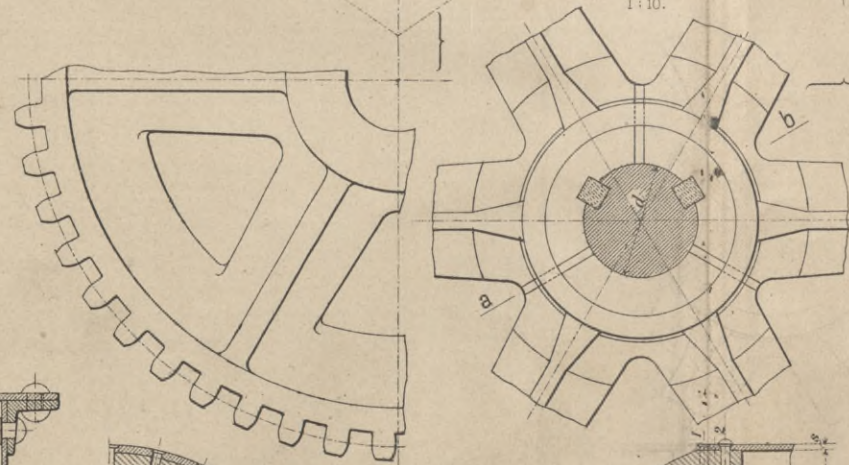


Fig. 77. 1:10.

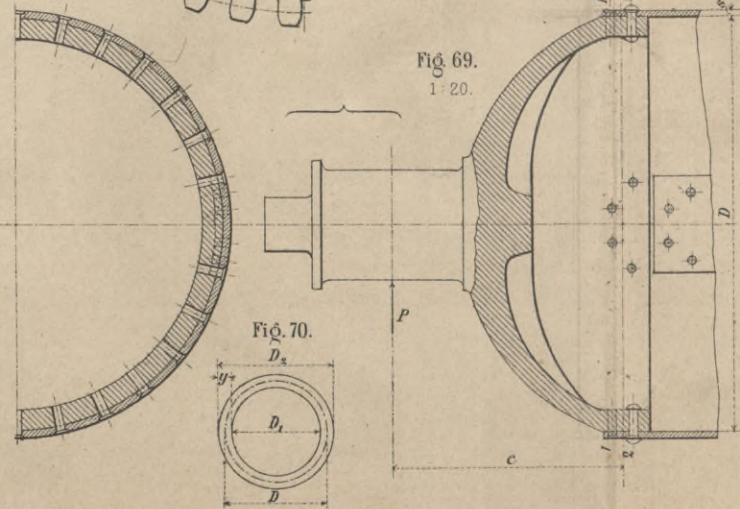


Fig. 69. 1:20.

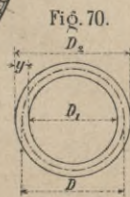
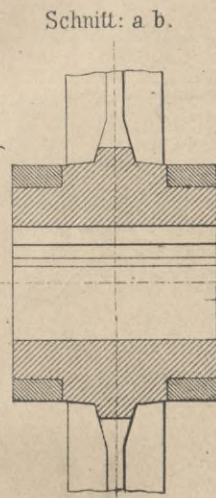


Fig. 70. D_s, D_i, D.



Schnitt: a b.

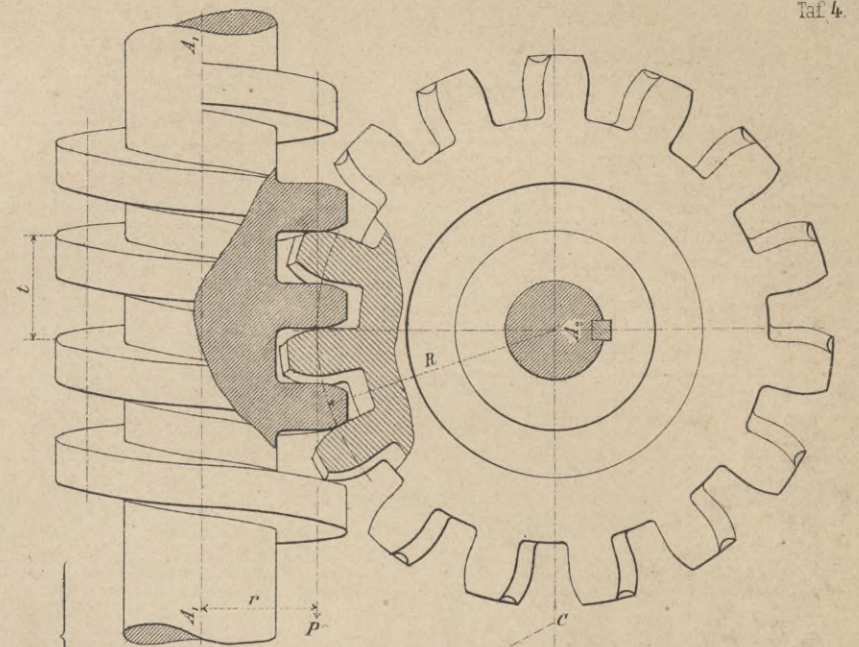


Fig. 72.

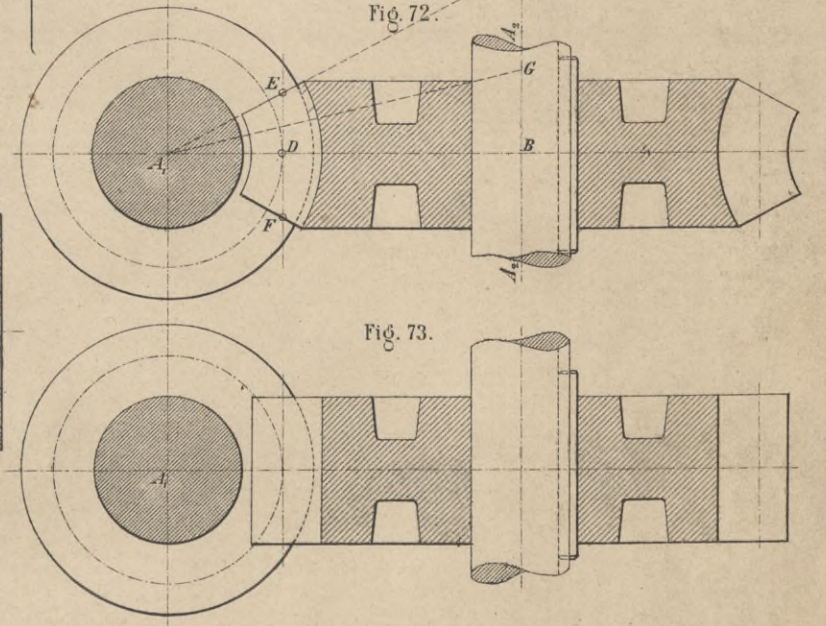


Fig. 73.

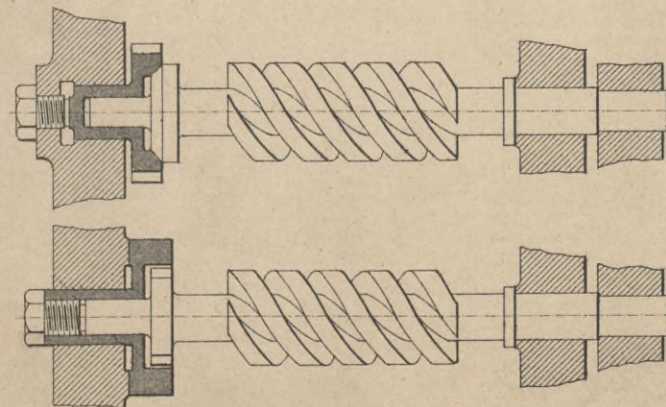


Fig. 74.



Fig. 75.

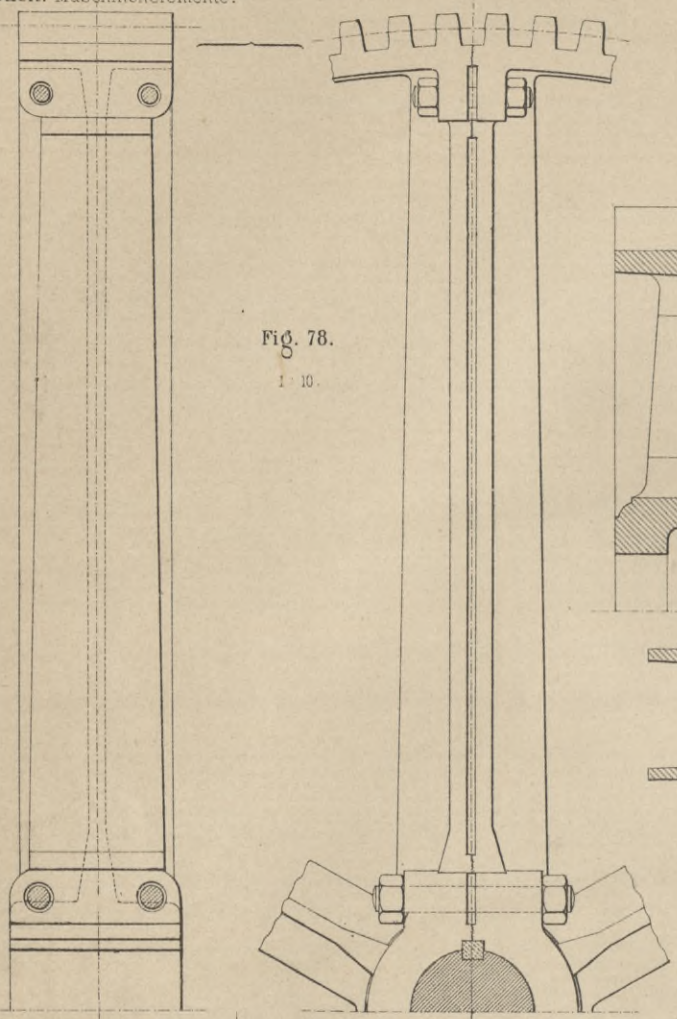


Fig. 78.
1:10.

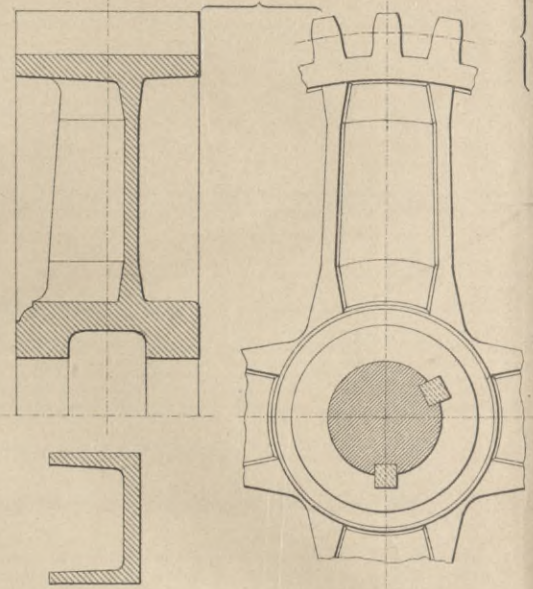


Fig. 76.
1:10.

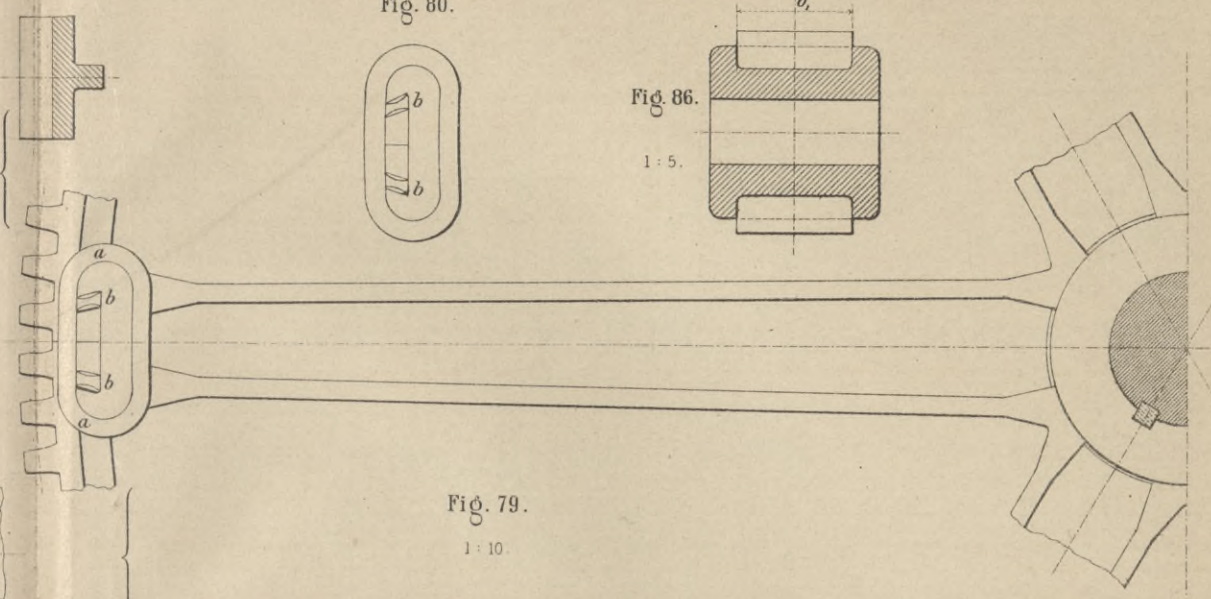


Fig. 79.
1:10.

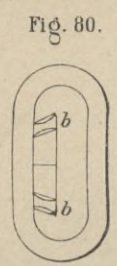


Fig. 80.

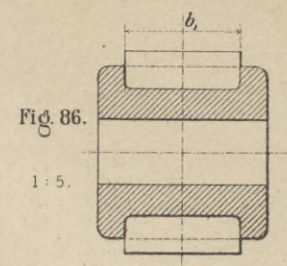


Fig. 86.
1:5.

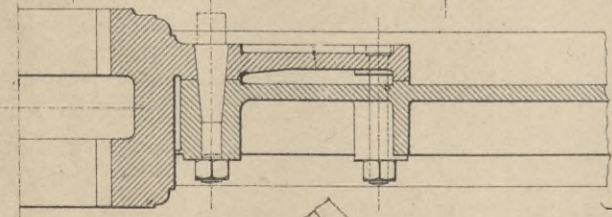
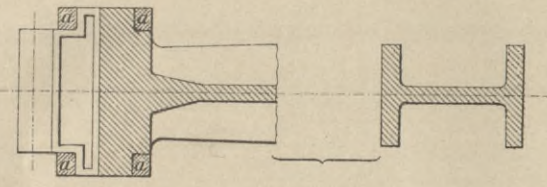


Fig. 82.
1:10.

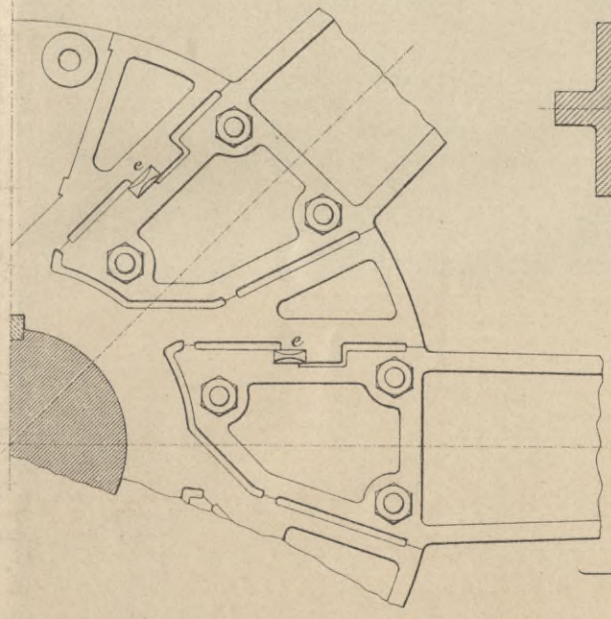
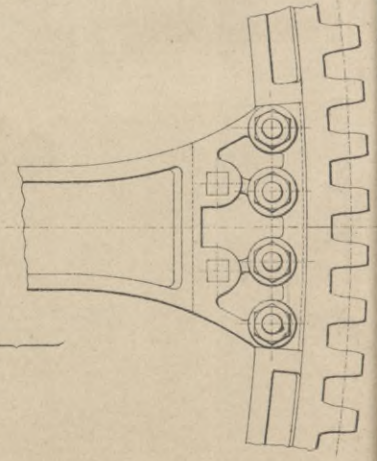
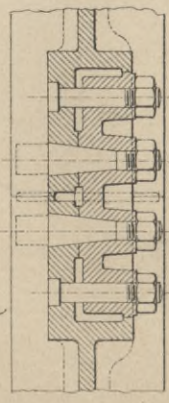
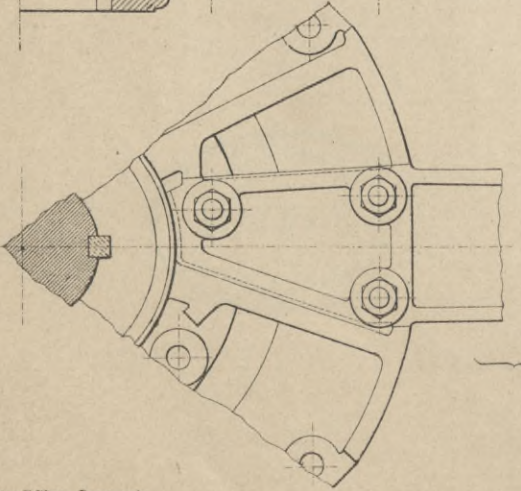
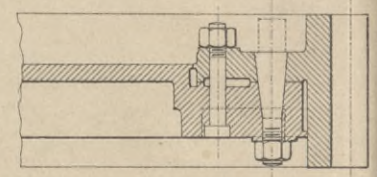


Fig. 81.
1:10.

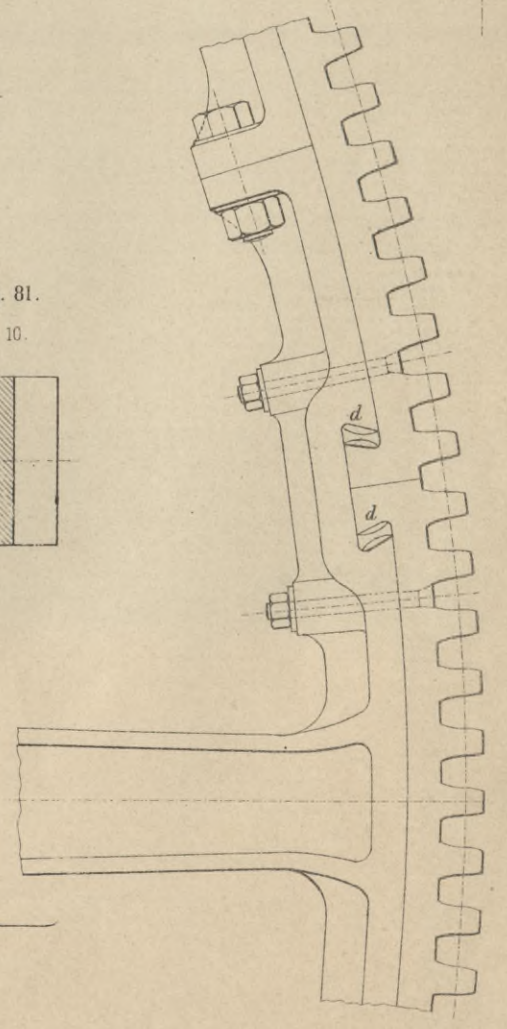
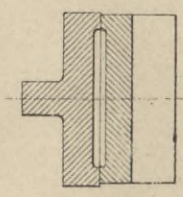


Fig. 90.

1:2.

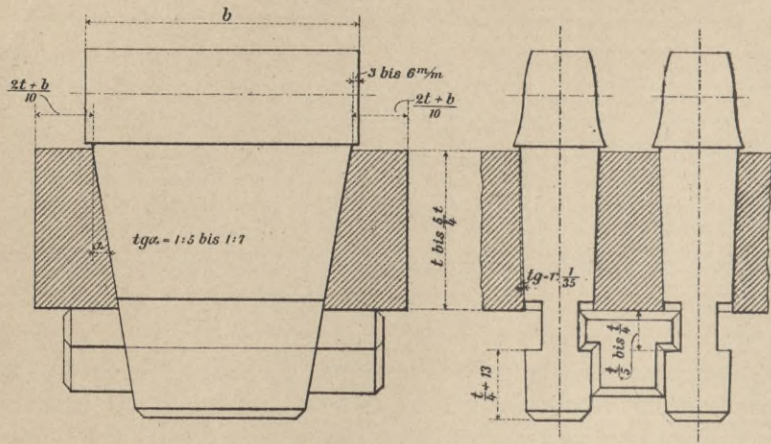


Fig. 91.

1:2.

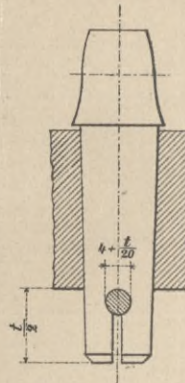


Fig. 95.

1:2.

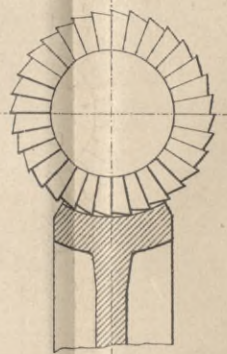


Fig. 88.

1:10.

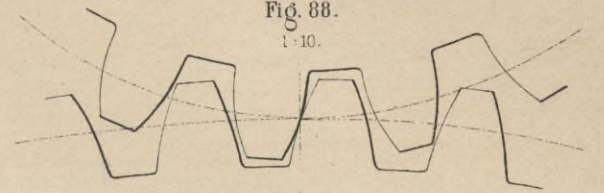


Fig. 83.

1:10.

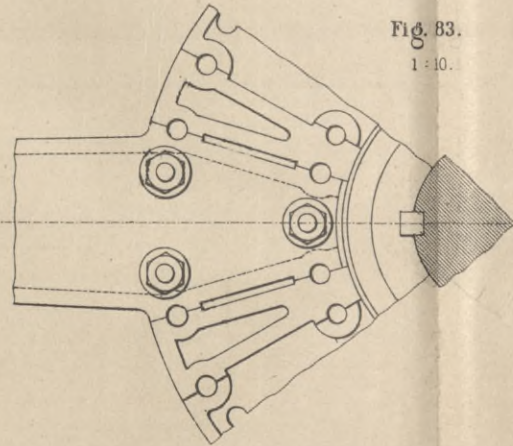


Fig. 94.

1:5.

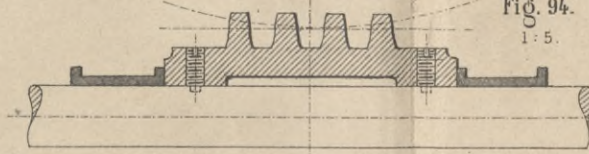
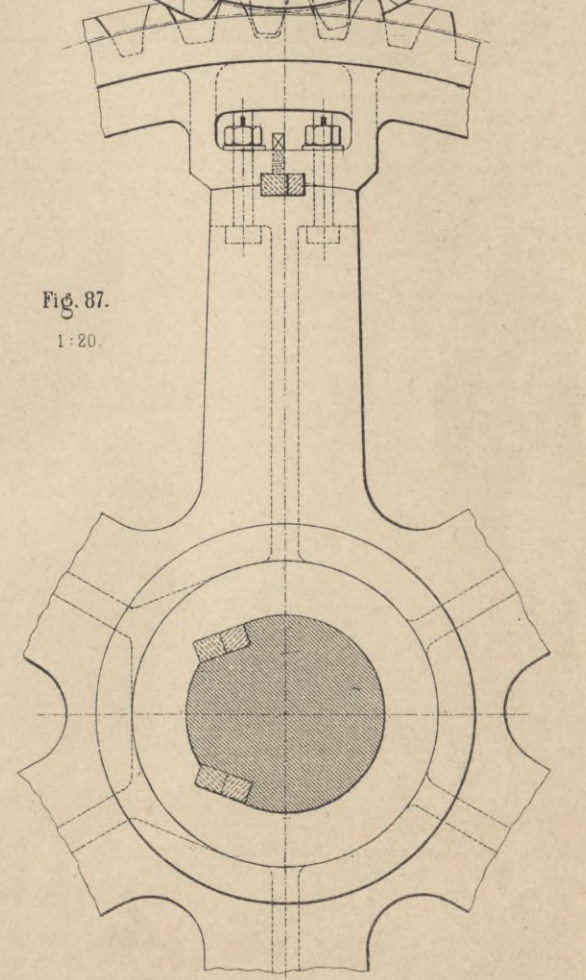


Fig. 87.

1:20.



Schnitt-c.d. in der Pfeilrichtung gesehen.

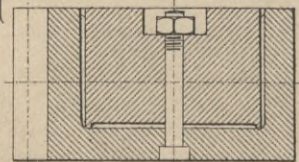
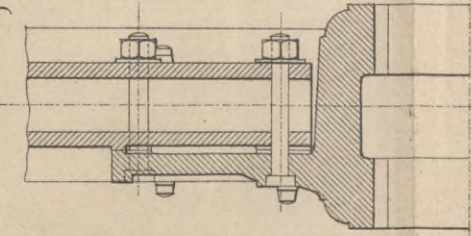
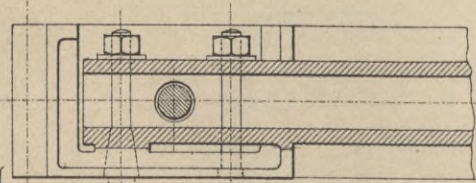
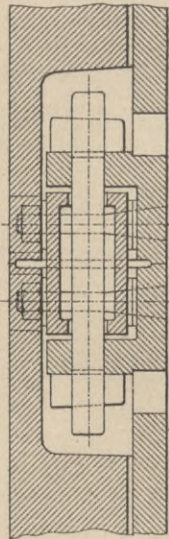
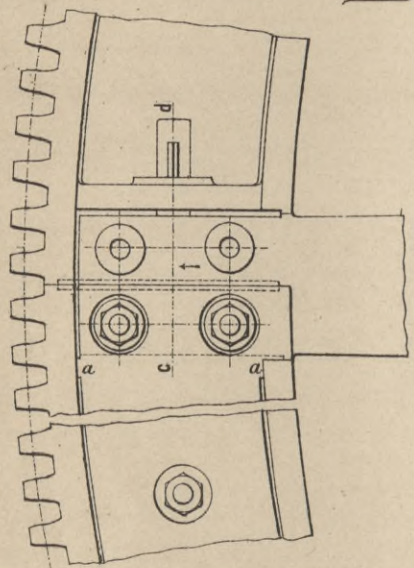
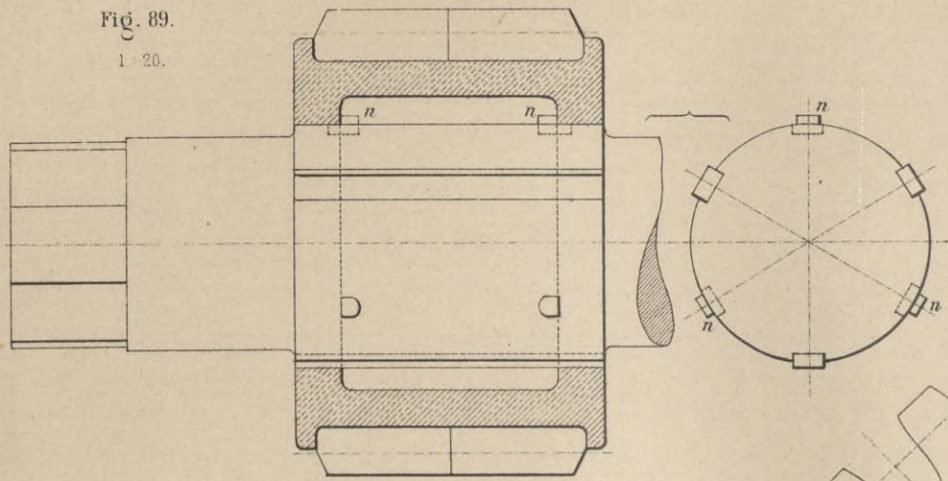


Fig. 89.
1 : 20.



Schnitt:
d-e.

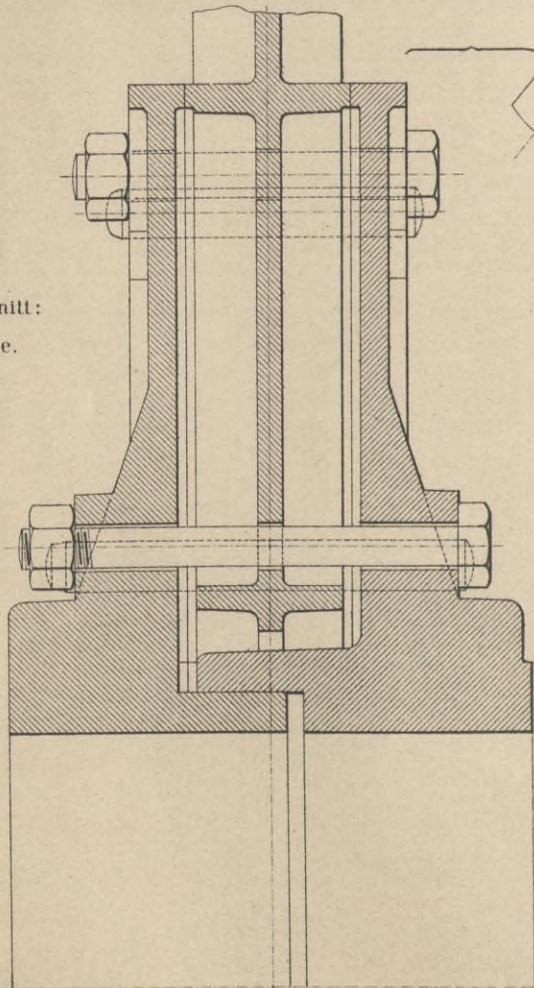


Fig. 84.
1 : 10.

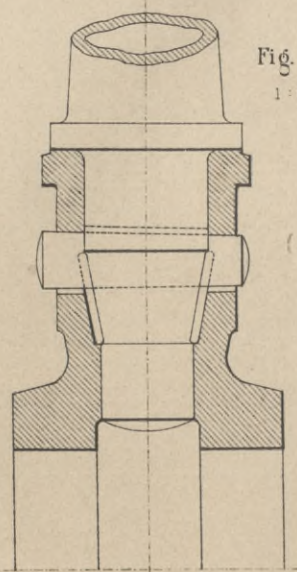
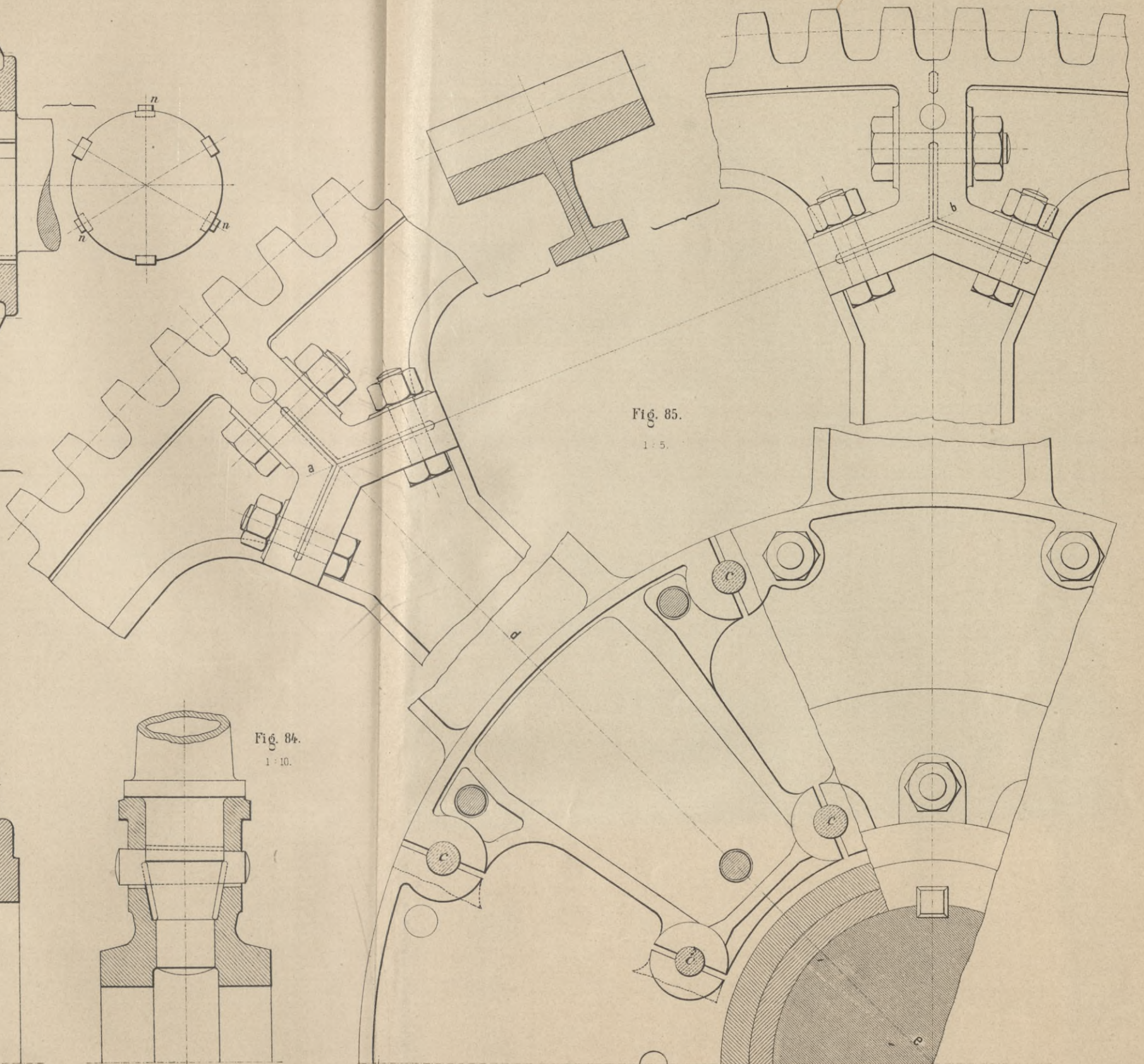
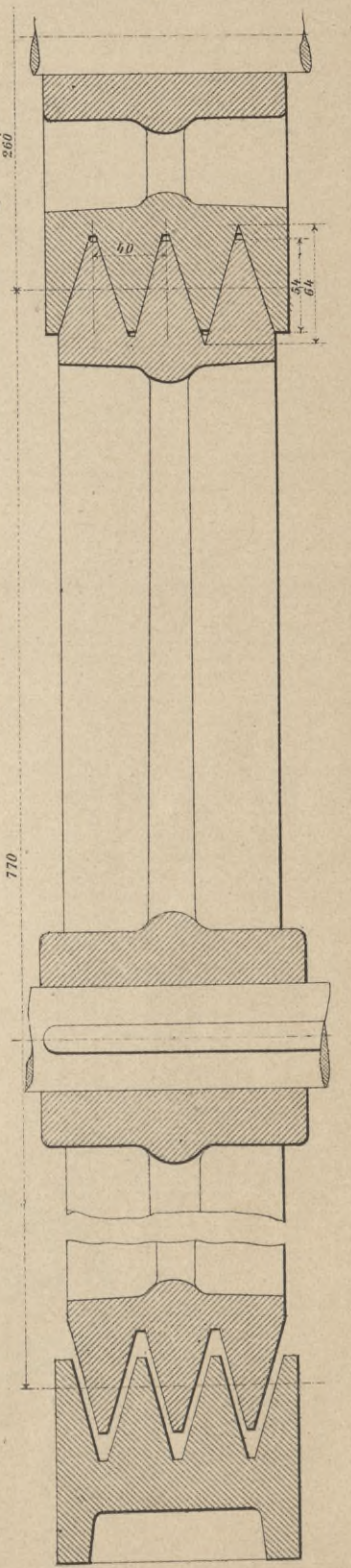
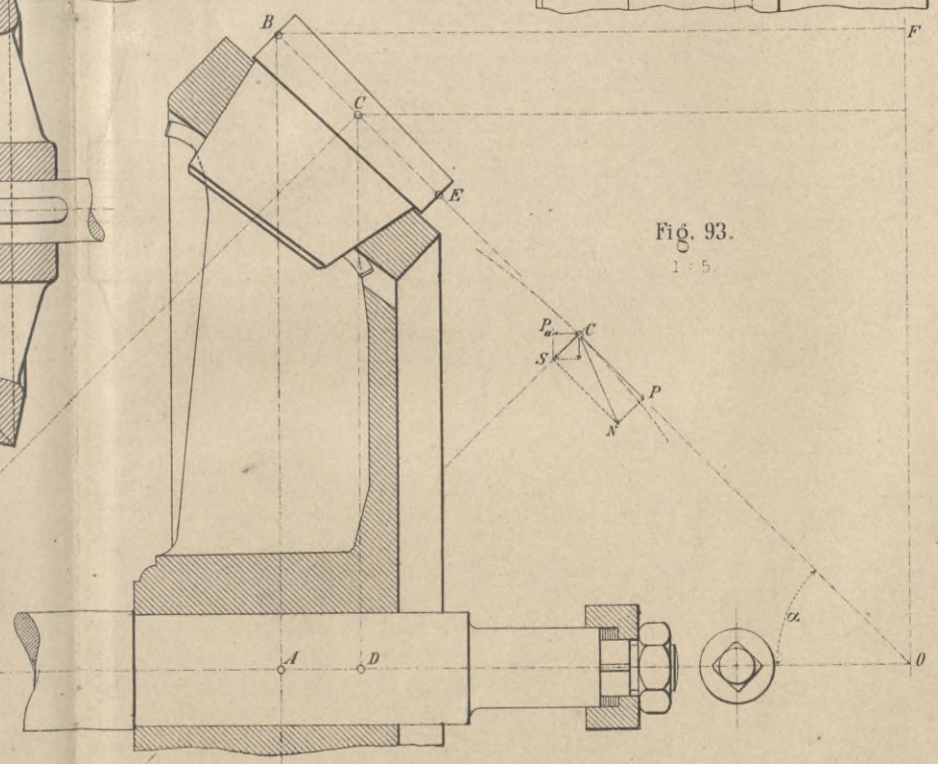
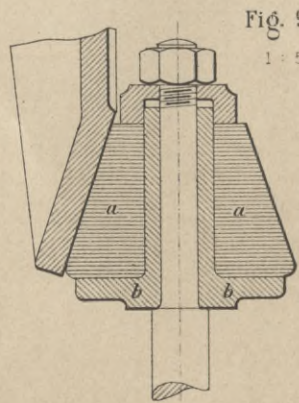
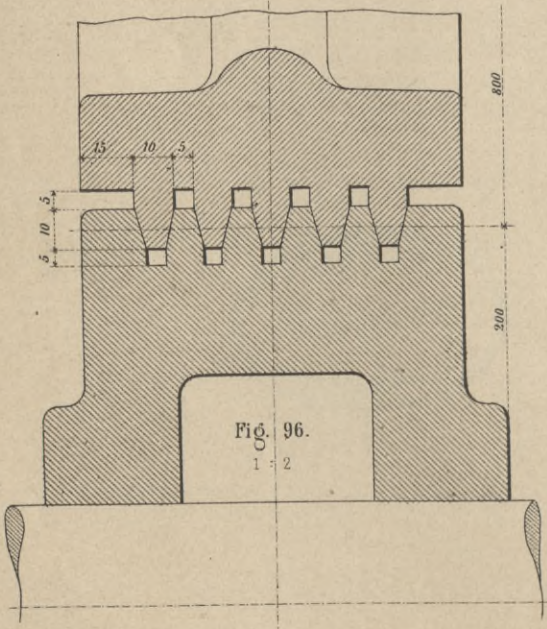
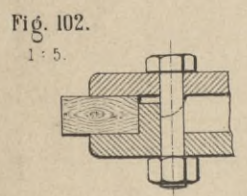
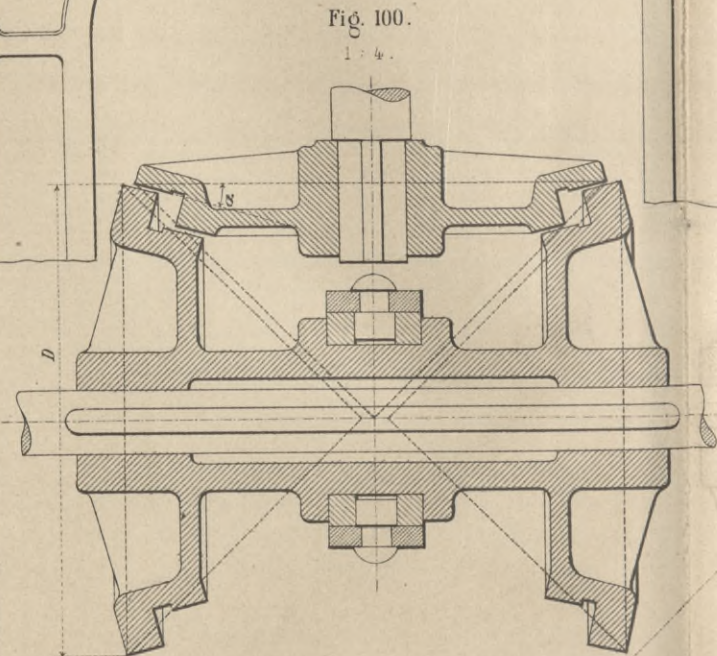
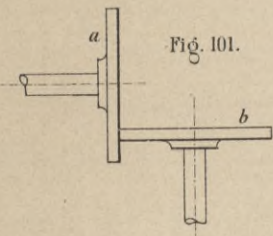
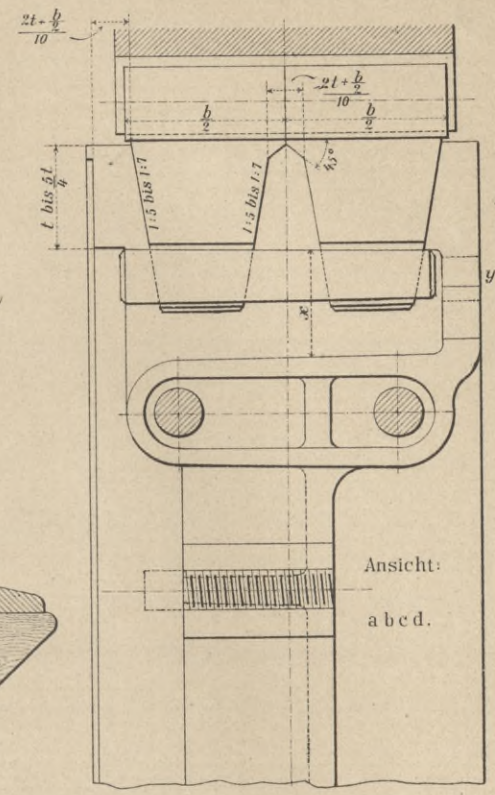
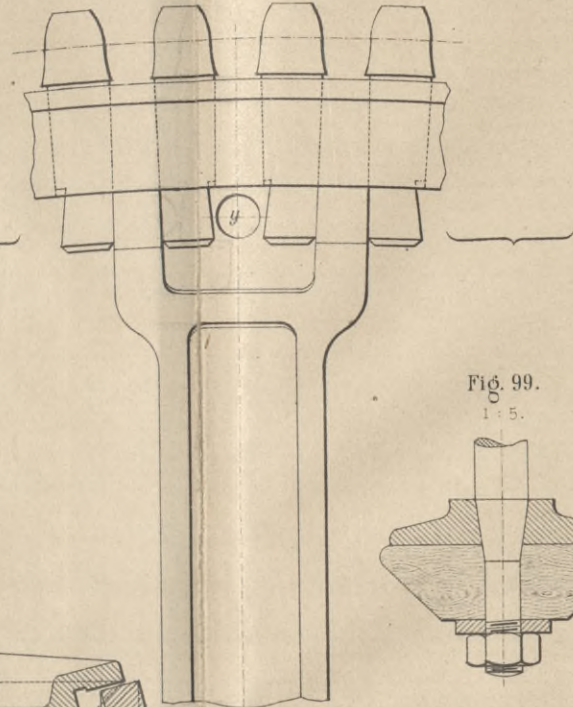
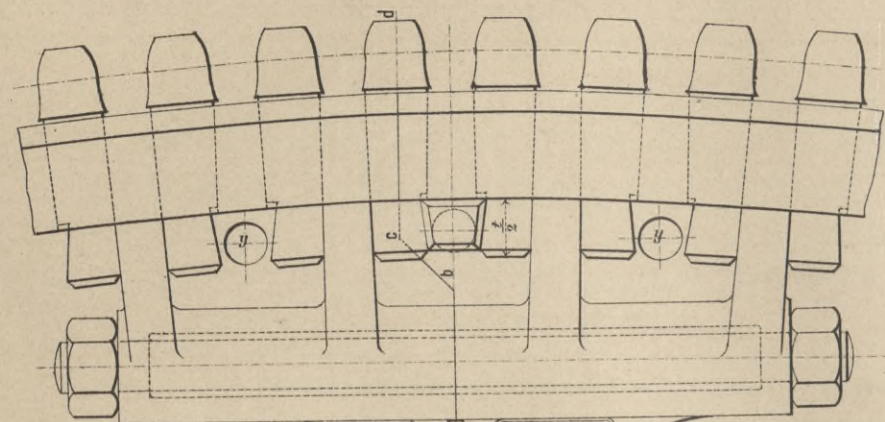


Fig. 85.
1 : 5.





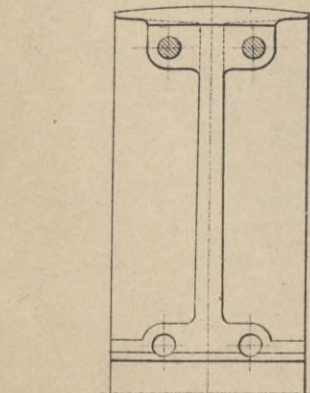
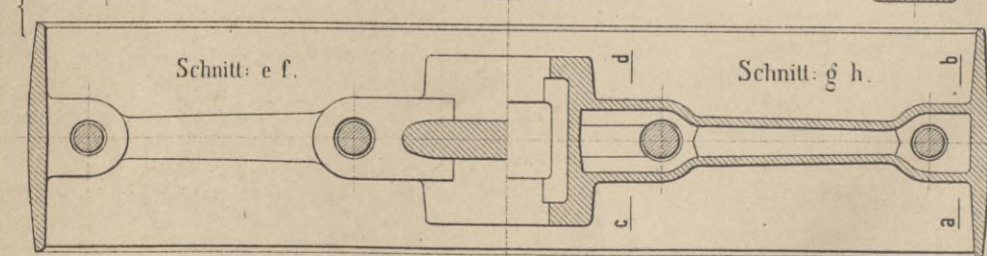
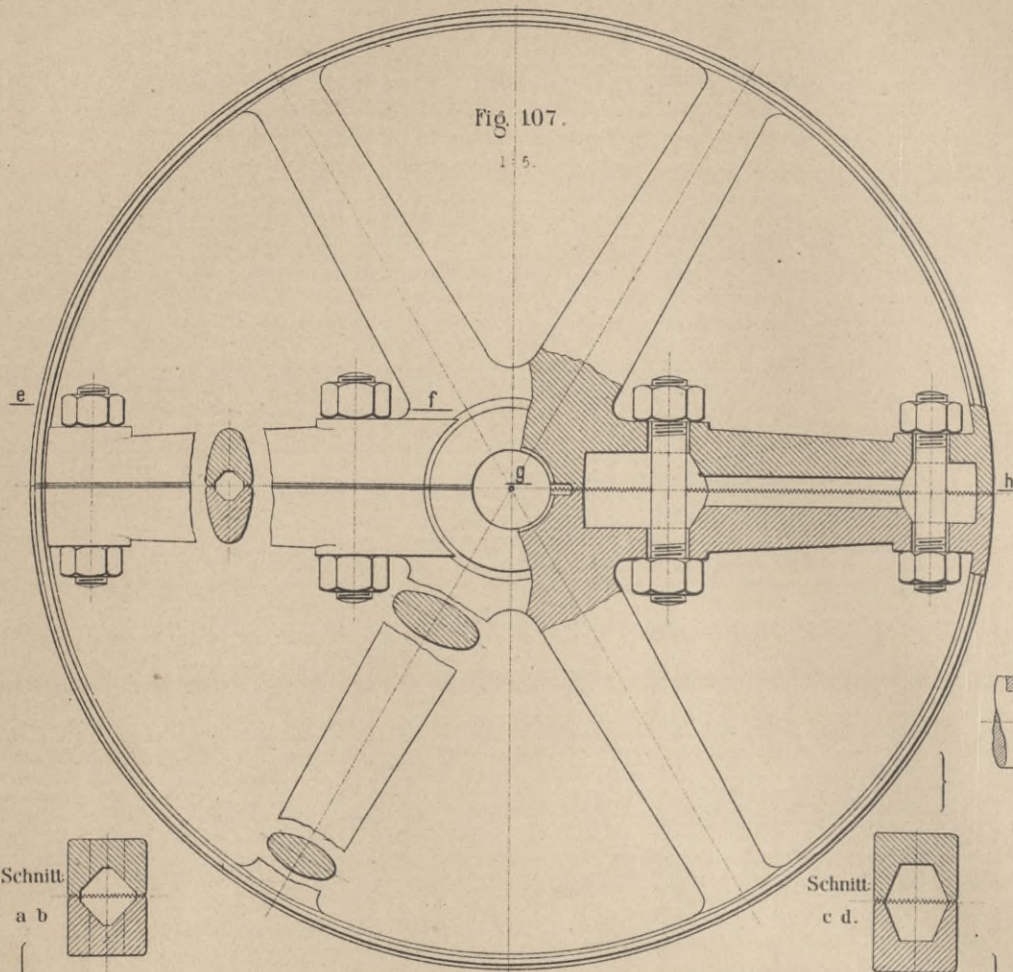


Fig. 106.
1:10.

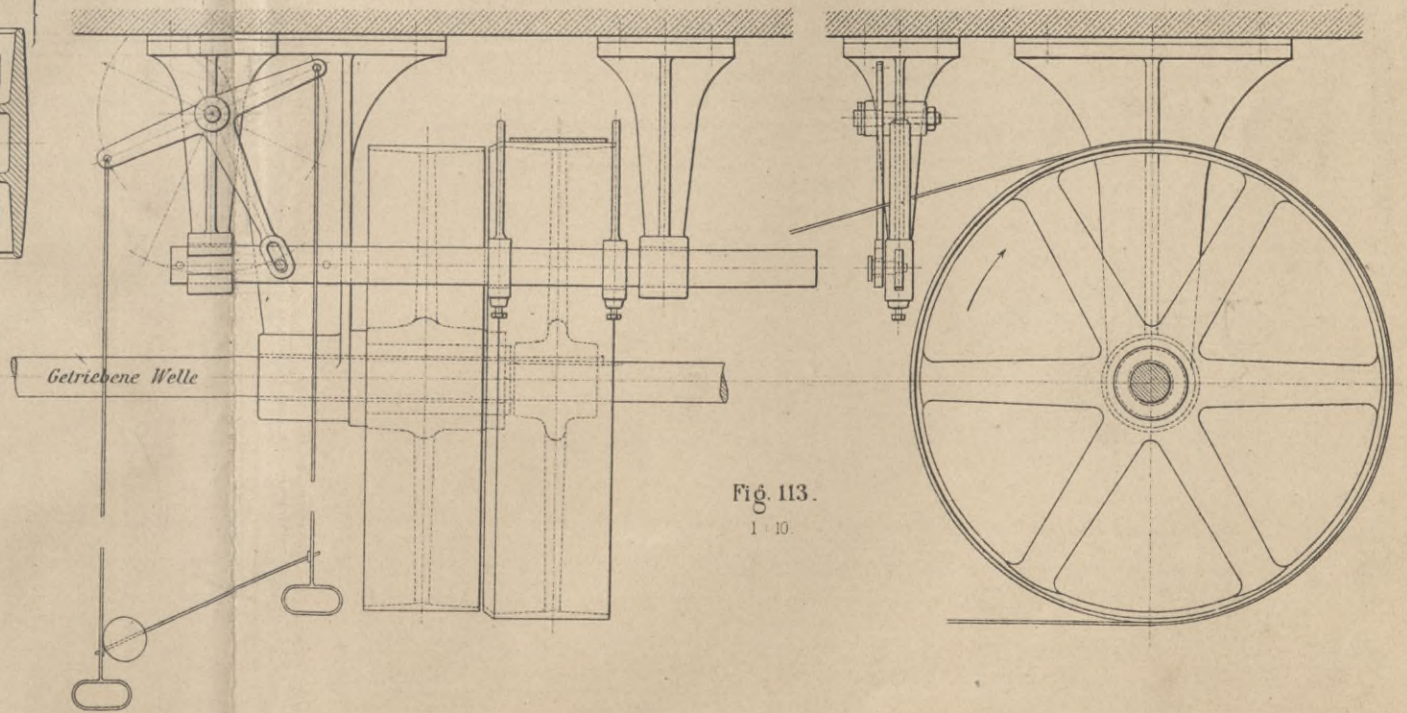
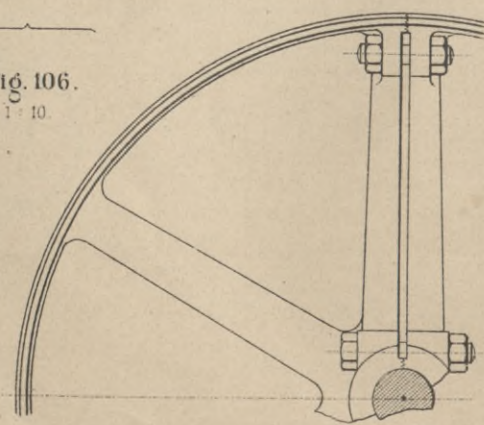


Fig. 113.
1:10.

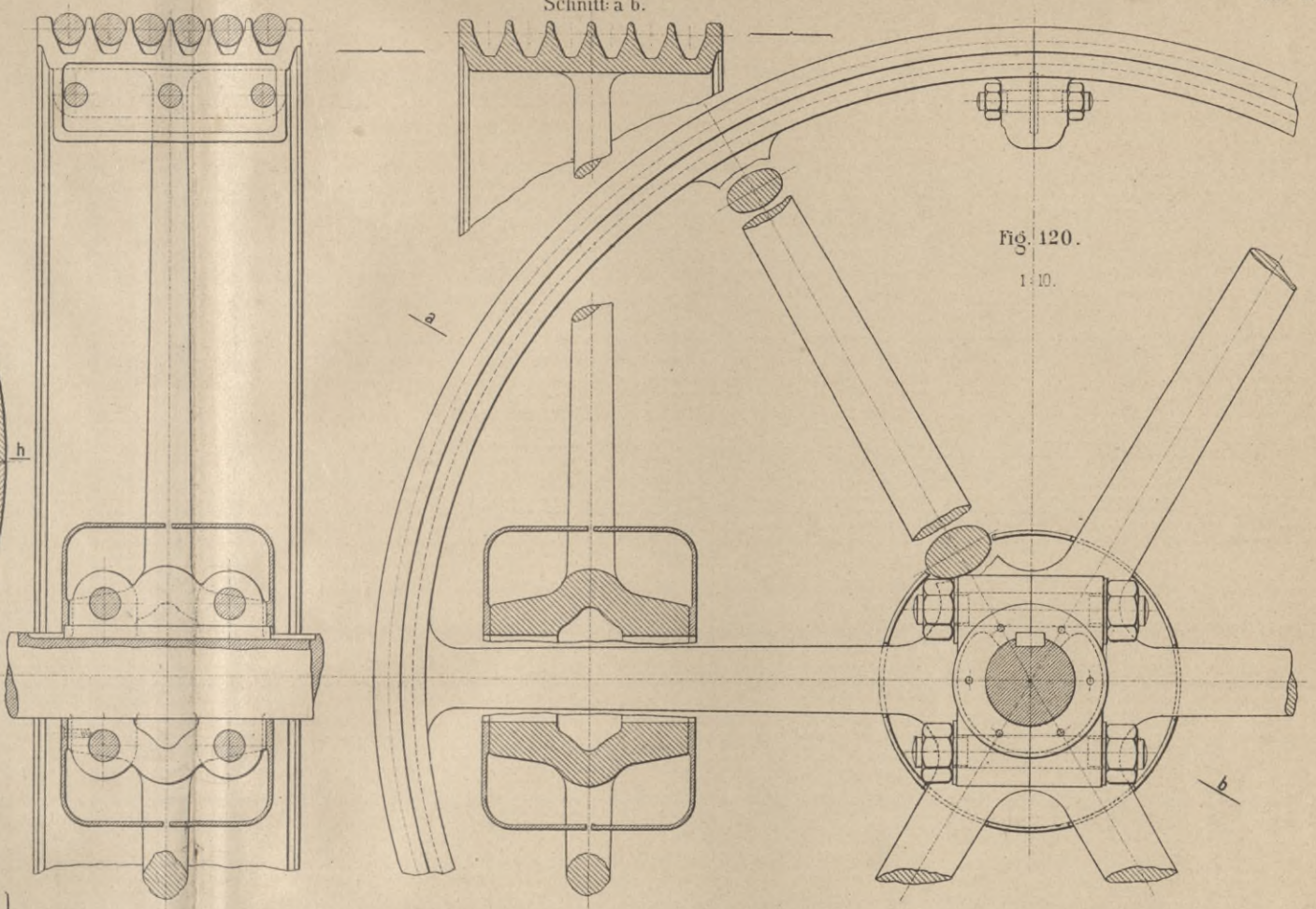


Fig. 120.
1:10.

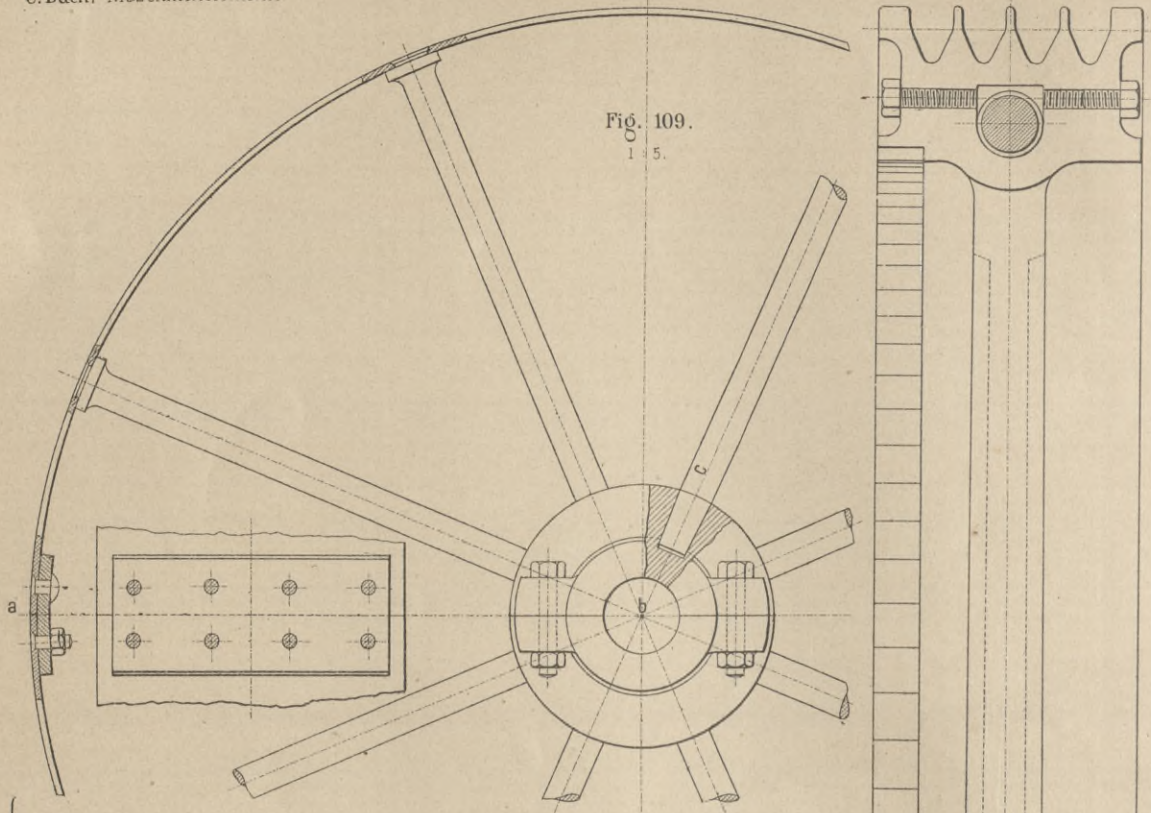


Fig. 109.
1 : 5.

Schnitt: a b c.

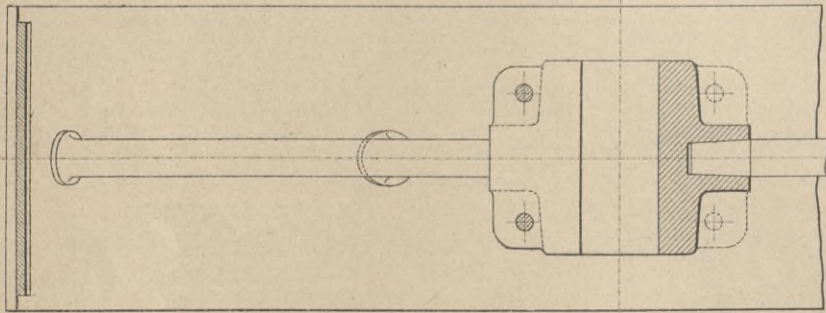


Fig. 116.
1 : 10.

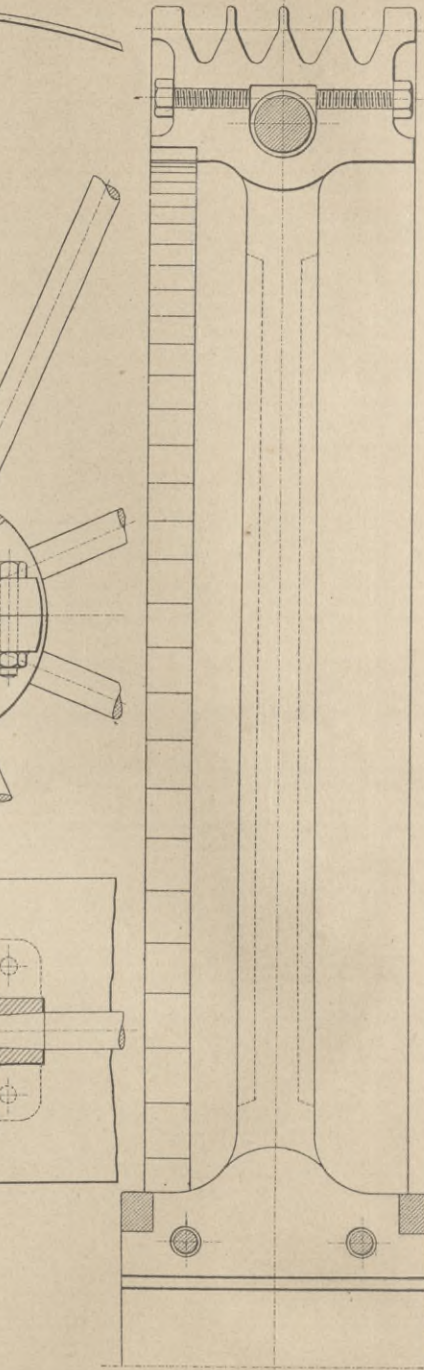
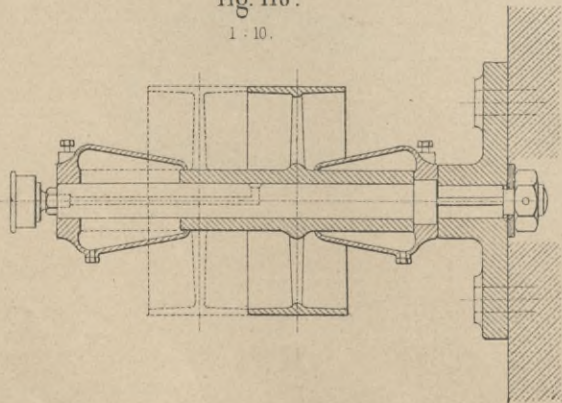


Fig. 108.
1 : 10.

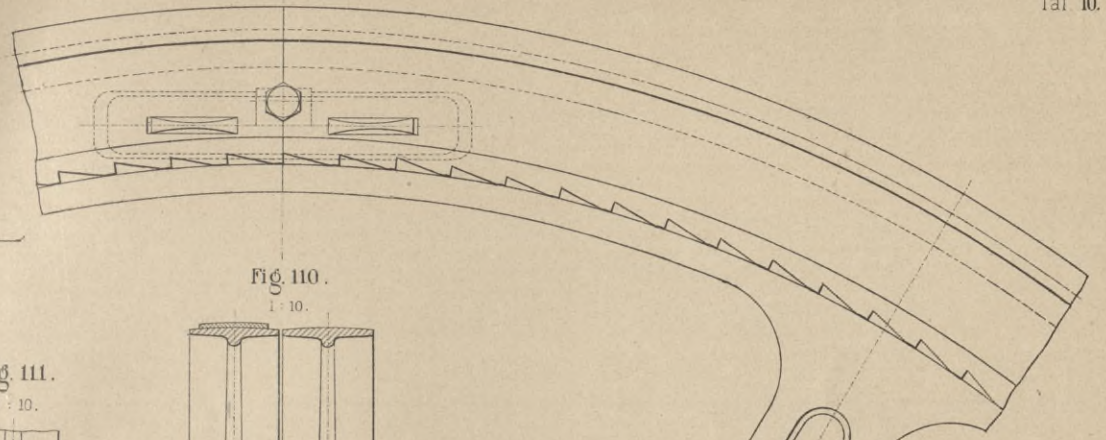
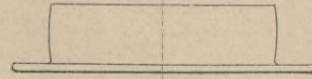


Fig. 110.
1 : 10.

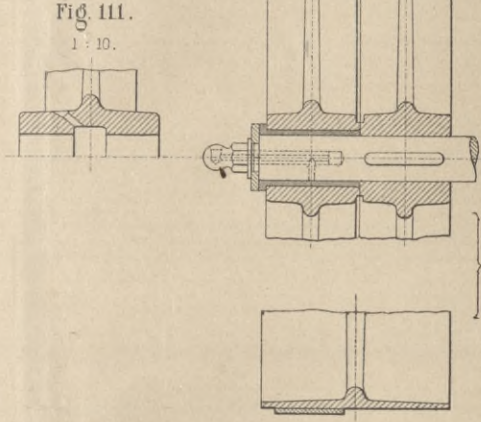


Fig. 111.
1 : 10.

Fig. 121.
1 : 10.

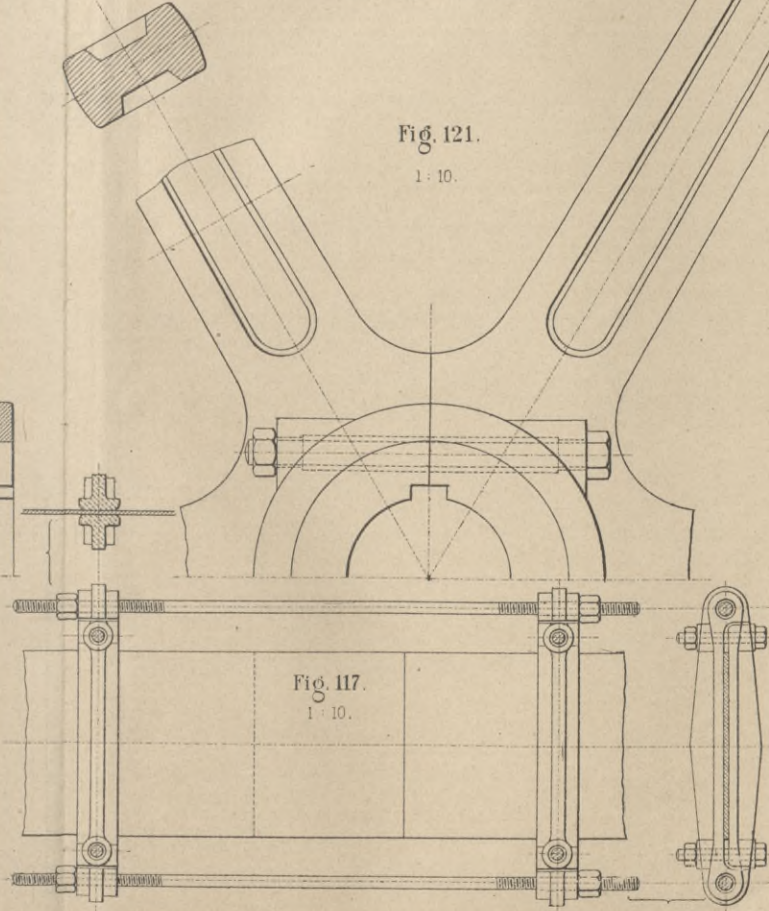


Fig. 117.
1 : 10.

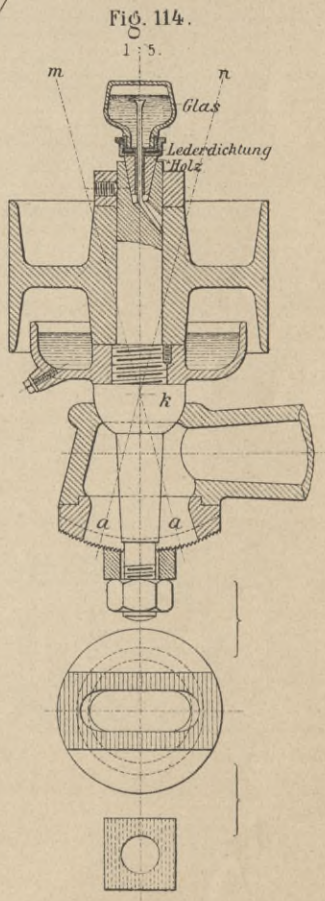
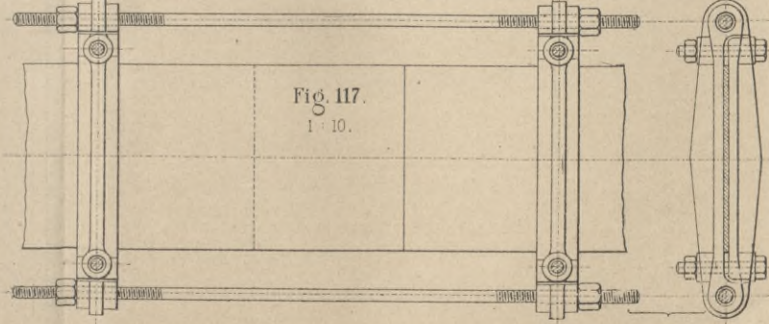
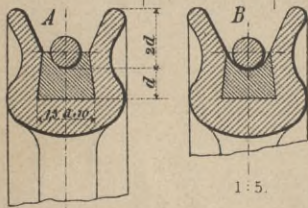
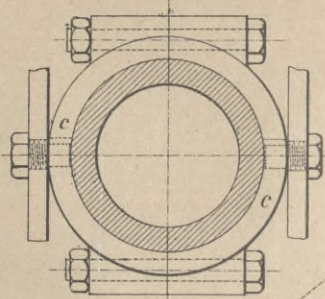
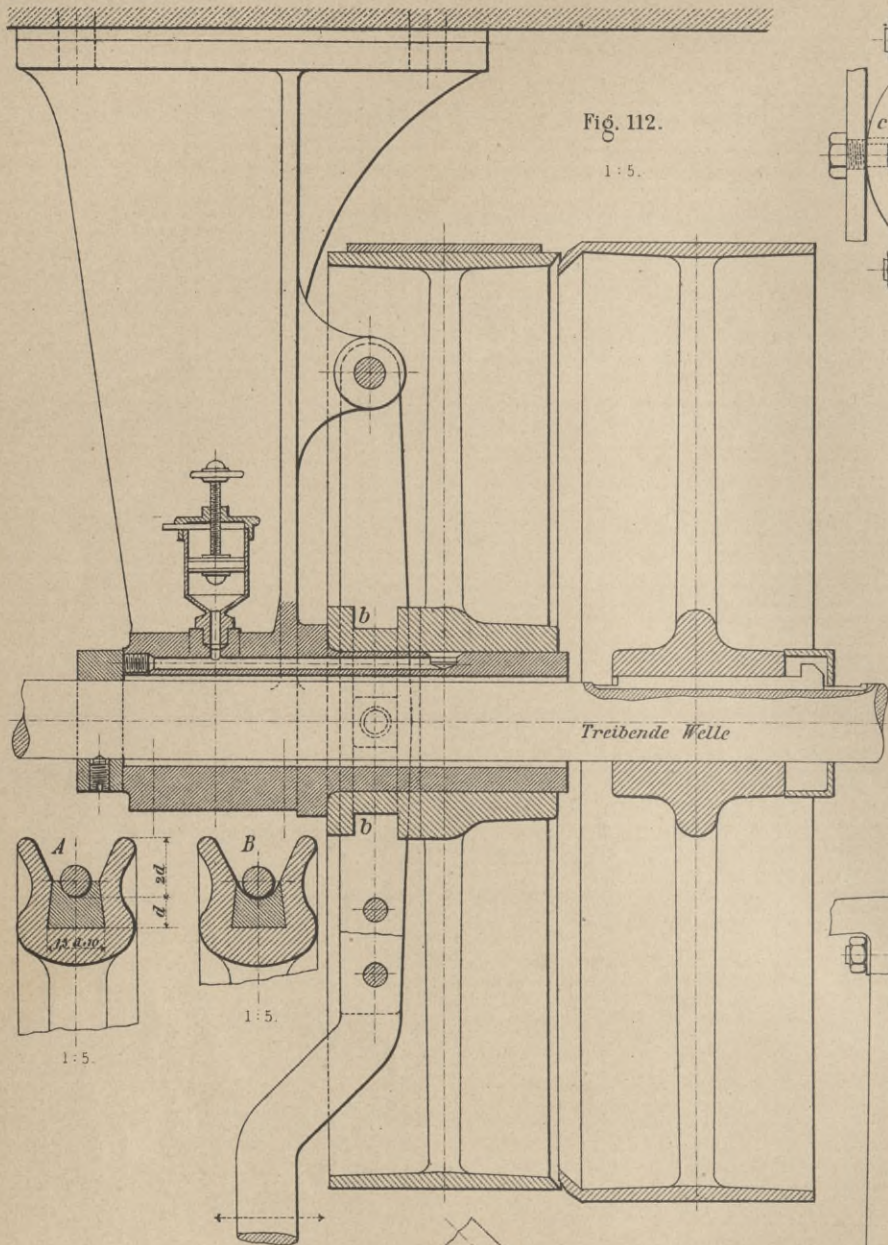


Fig. 114.
1 : 5.

Fig. 112.

1:5.



1:5.

1:5.

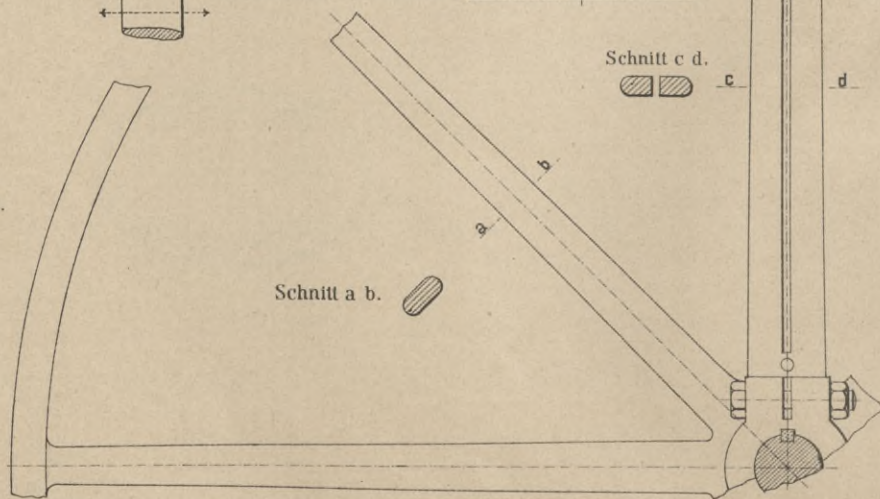
Schnitt c d.



d

Fig. 118.

1:20.

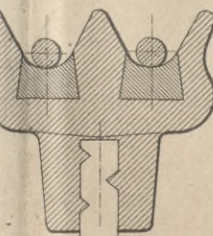
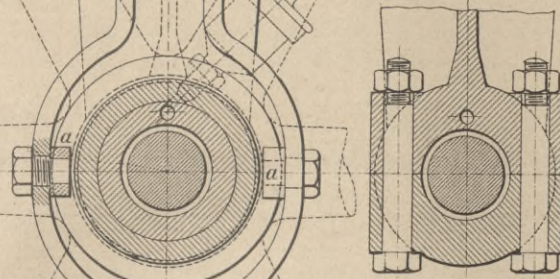
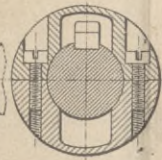
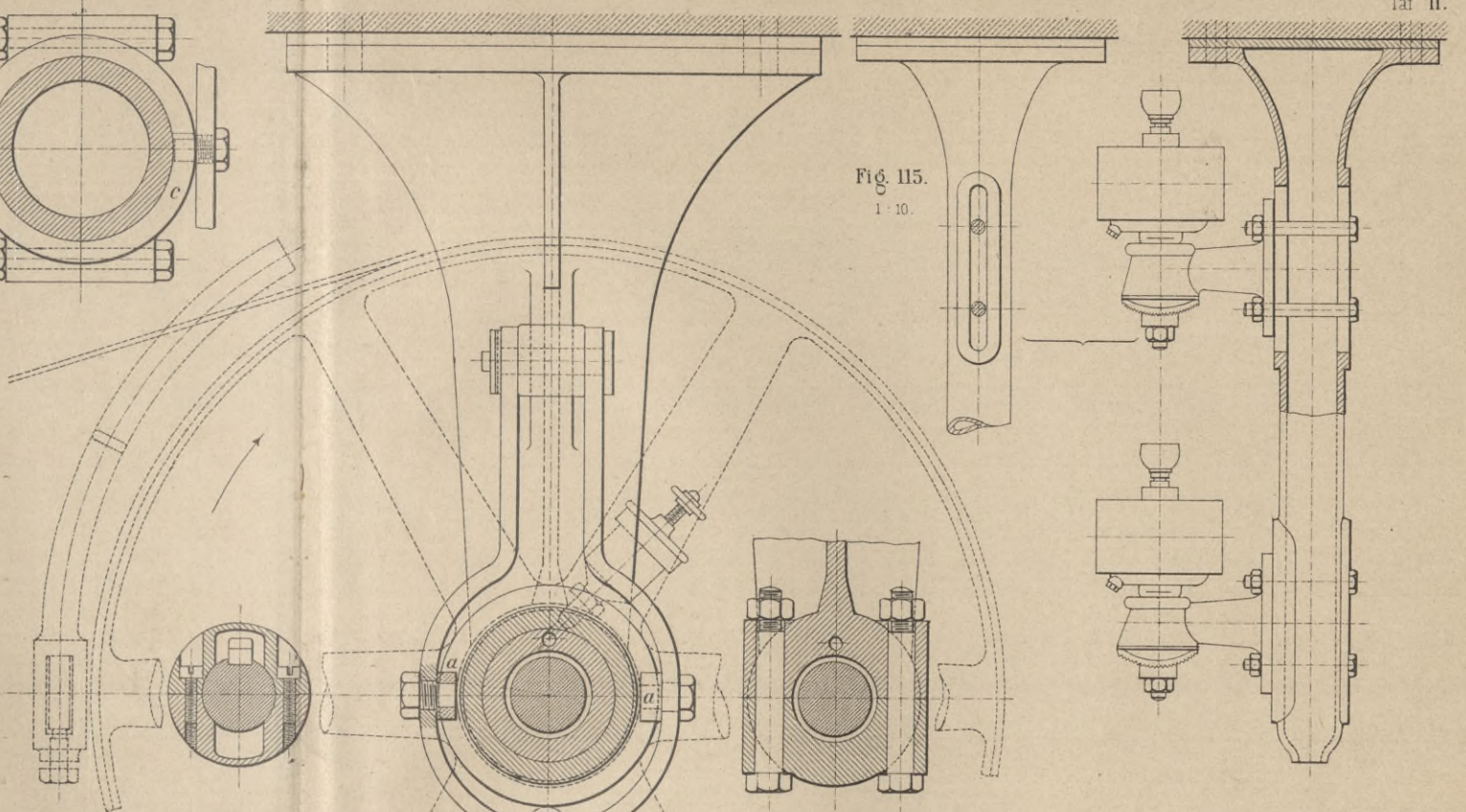


Schnitt a b.



Fig. 115.

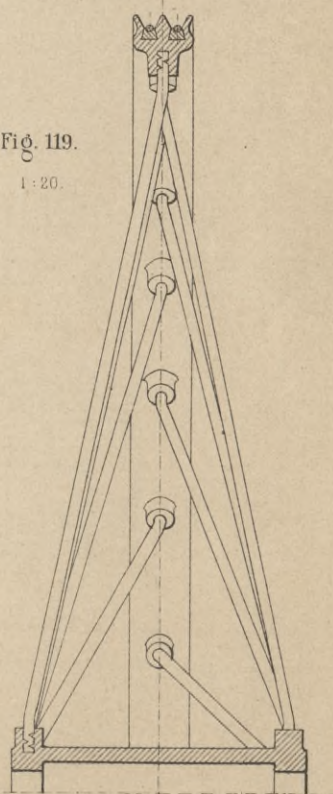
1:10.



1:5.

Fig. 119.

1:20.



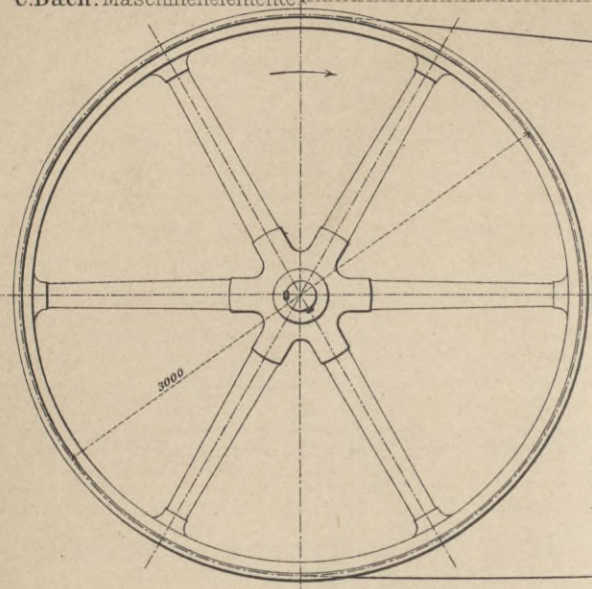


Fig. 122.

1:40

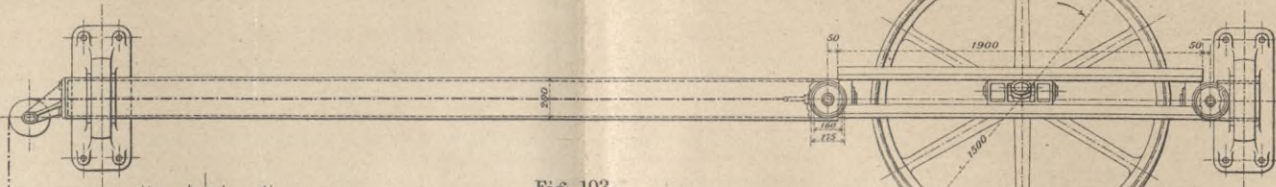


Fig. 103.

1:8

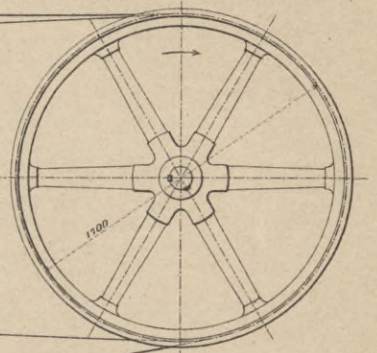


Fig. 125.

1:40

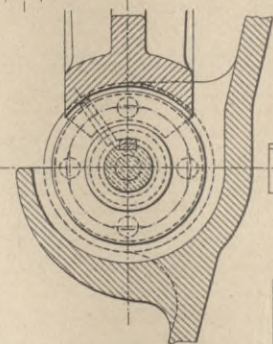


Fig. 105.

1:10

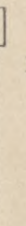


Fig. 104.

1:10

Fig. 124.

1:40

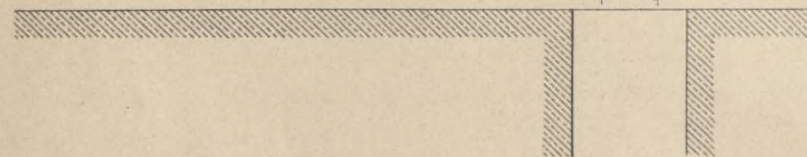
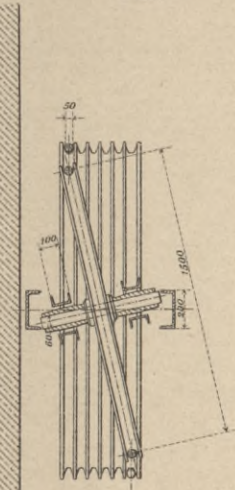


Fig. 126.

Fig. 127.

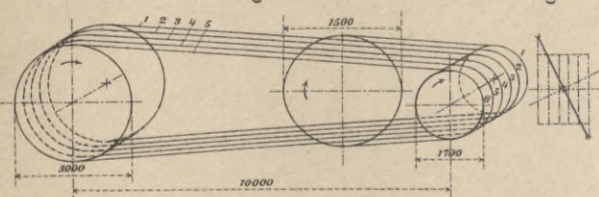


Fig. 123.

1:40

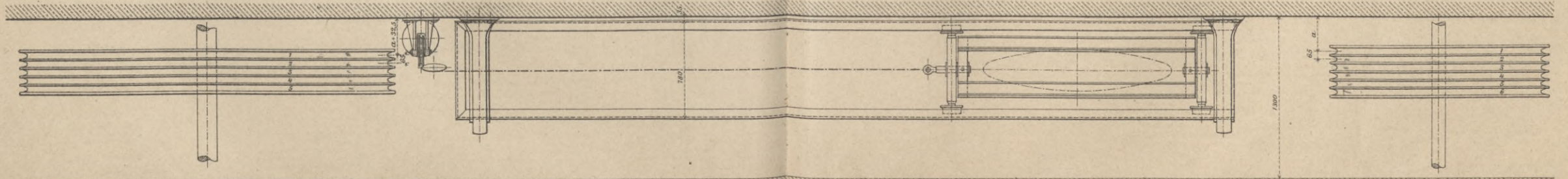


Fig. 128.
1:40.

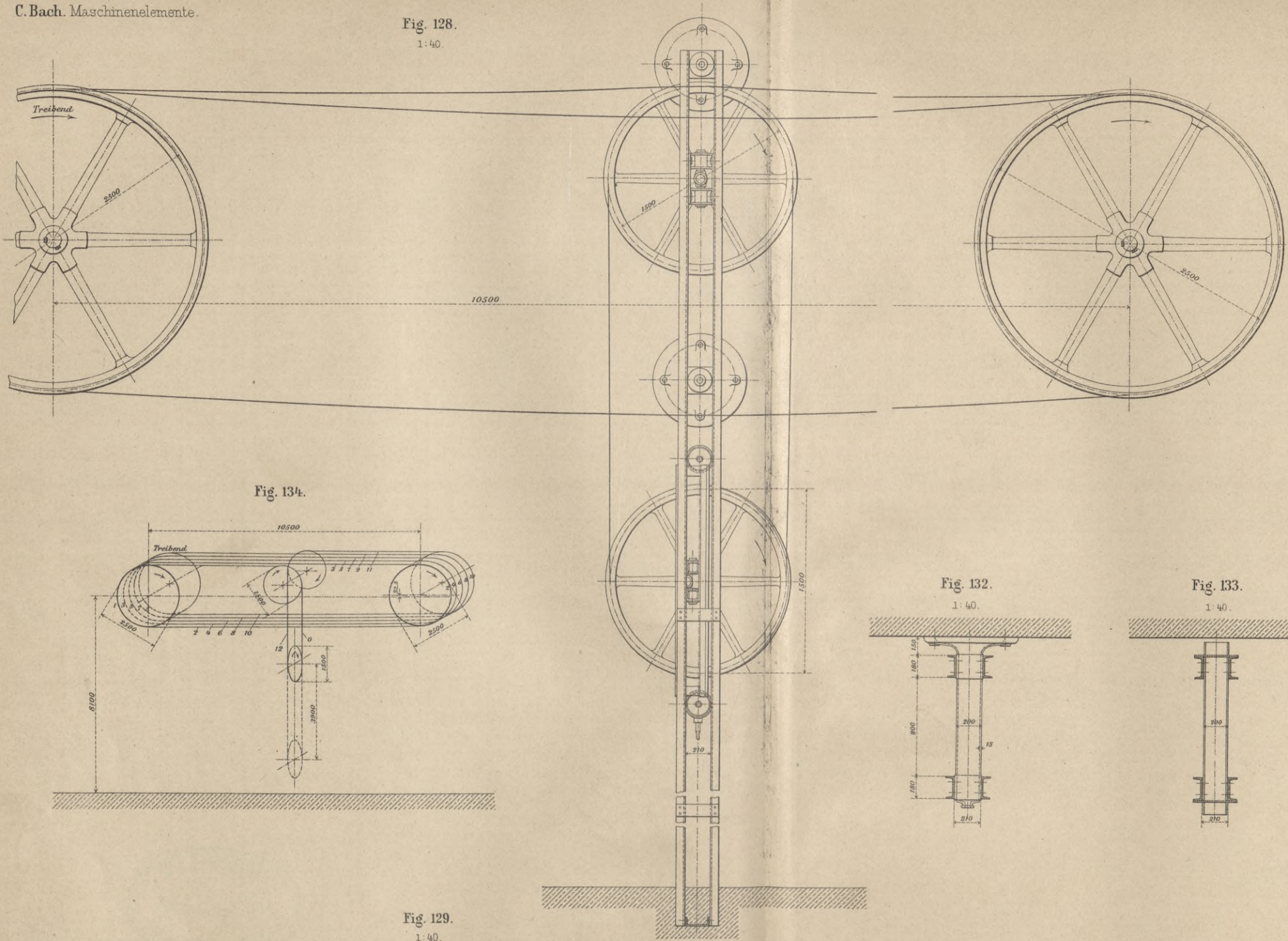


Fig. 134.

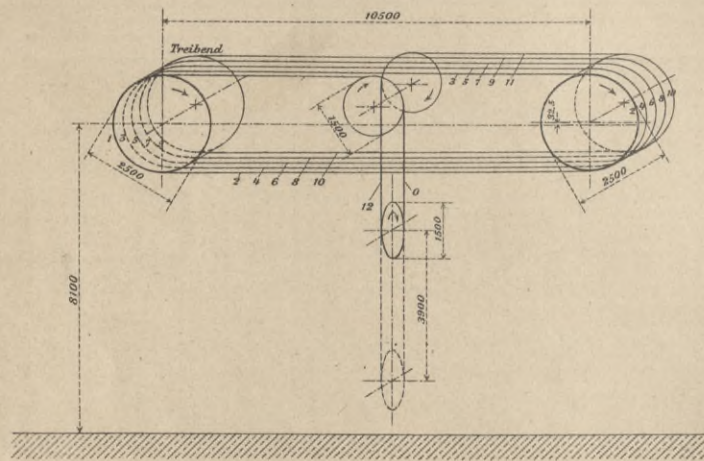


Fig. 129.
1:40.

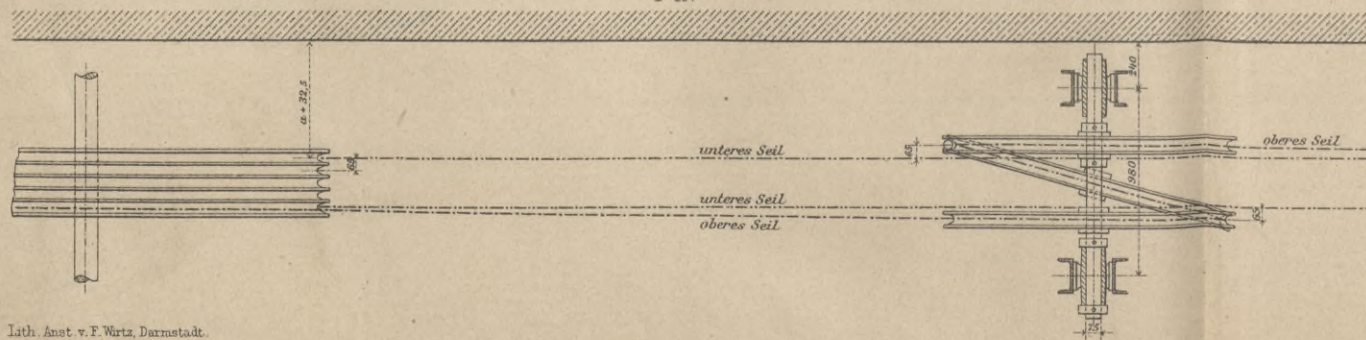


Fig. 132.
1:40.

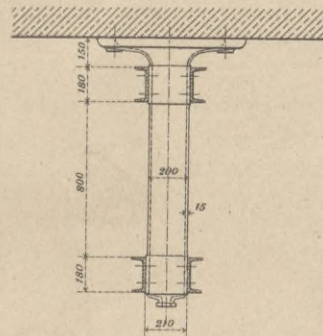


Fig. 133.
1:40.

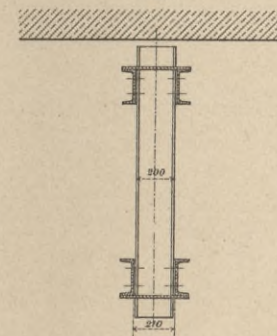


Fig. 130.
1:40.

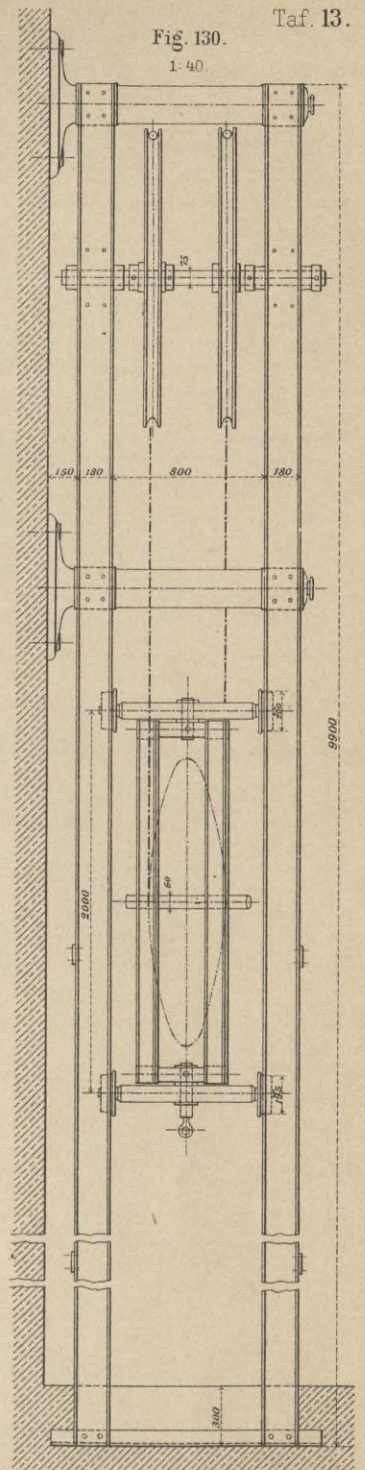
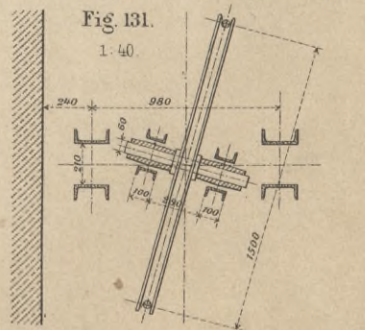


Fig. 131.
1:40.



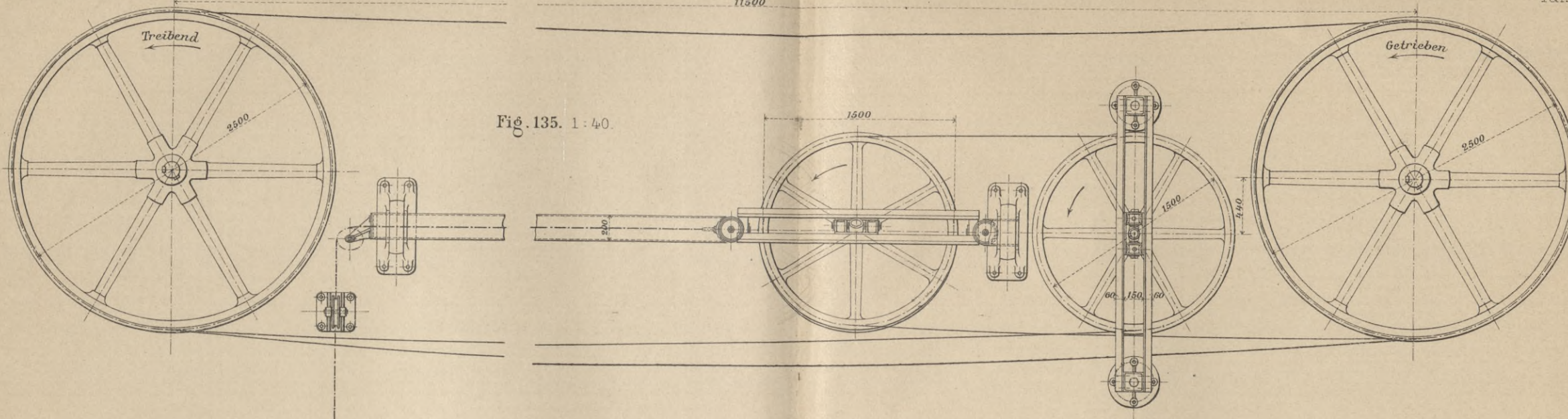


Fig. 135. 1:40.

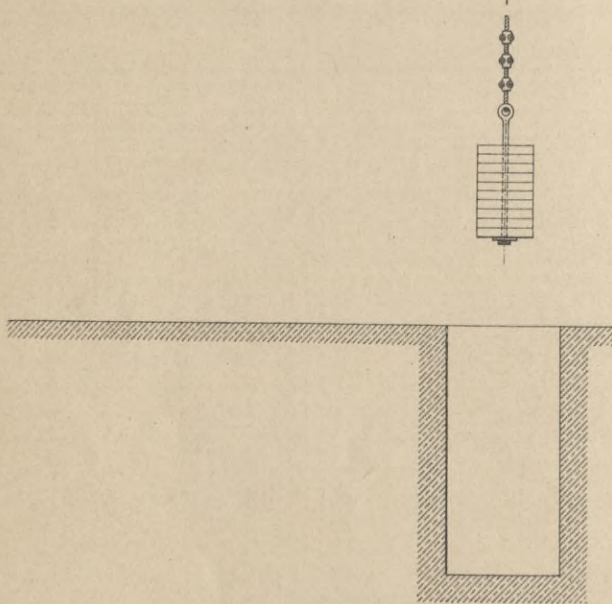


Fig. 140.

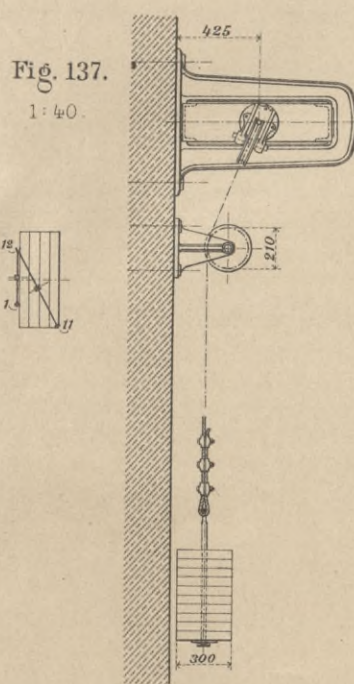


Fig. 137. 1:40.

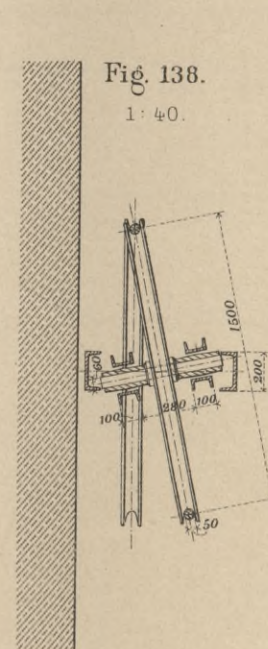


Fig. 138. 1:40.

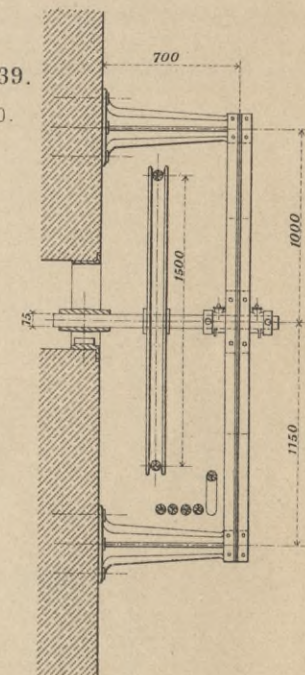


Fig. 139. 1:40.

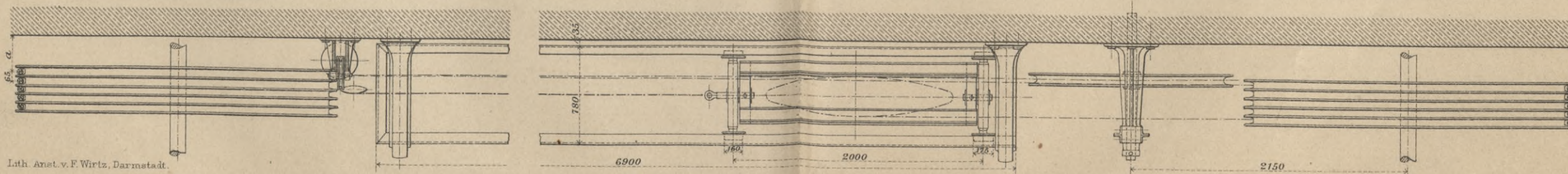


Fig. 136. 1:40.

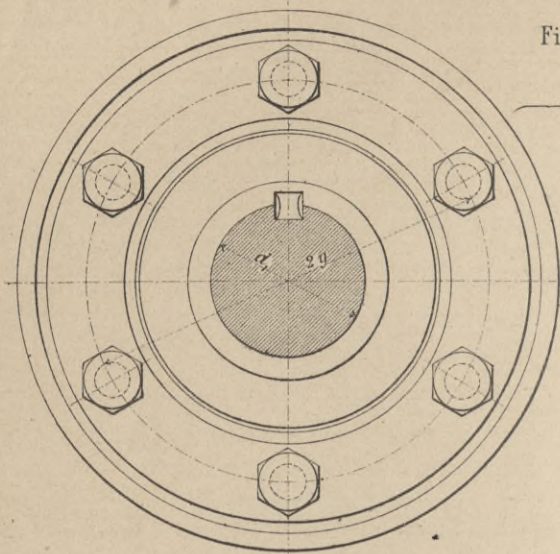


Fig. 162.
1:5.

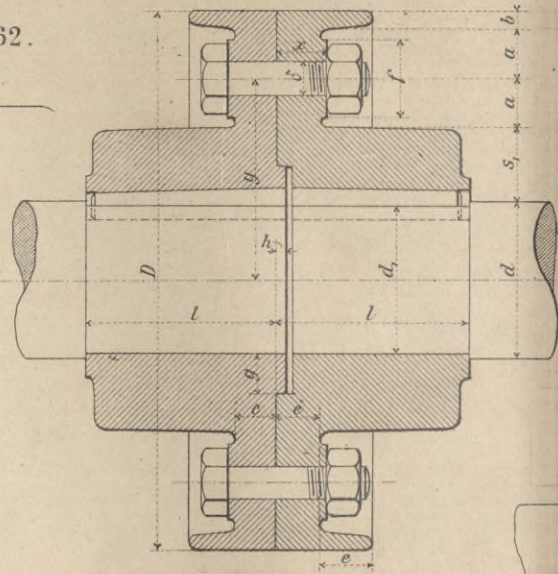


Fig. 163.
1:5.

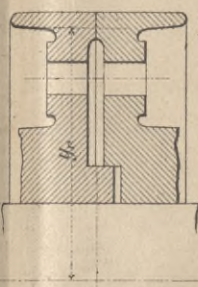


Fig. 167.

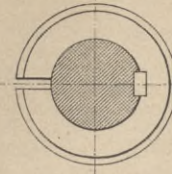


Fig. 166.
1:5.

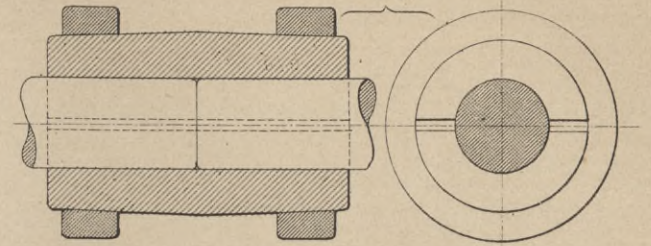


Fig. 168.
2:5.

Schnitt : a b.

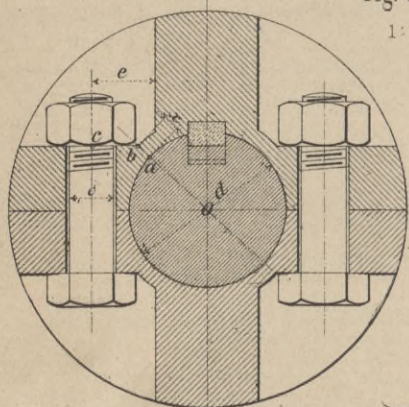
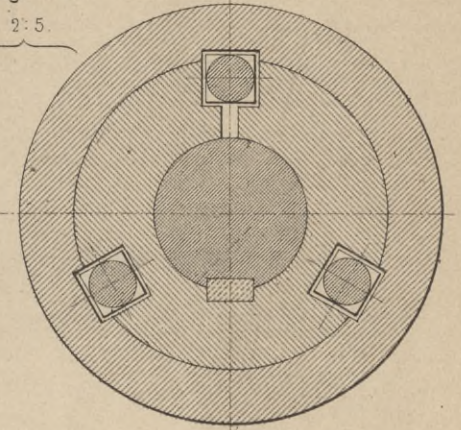


Fig. 164.
1:5.

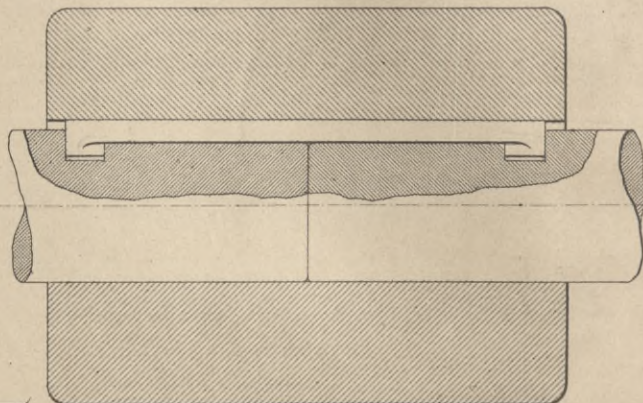


Fig. 161.
1:5.

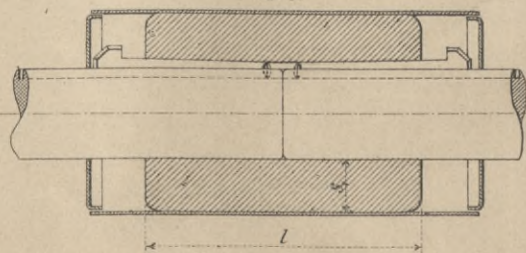
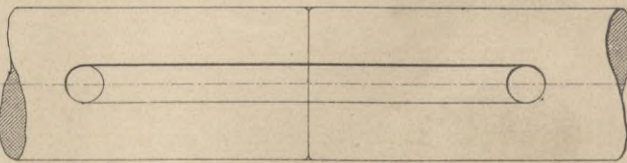


Fig. 165.
1:5.

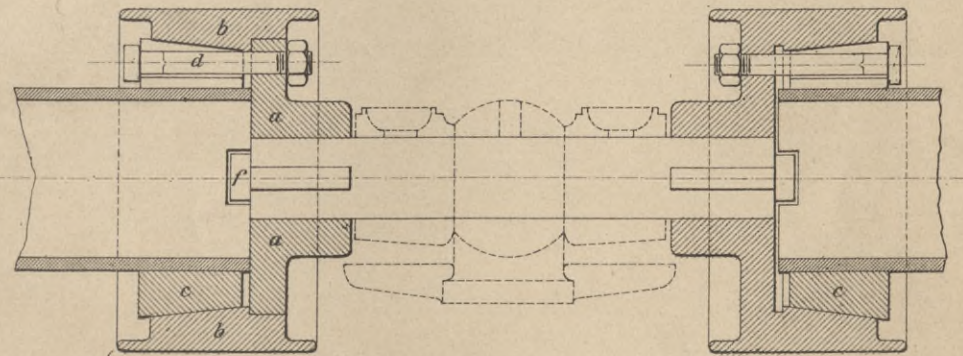
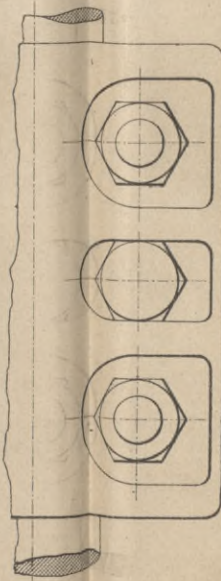
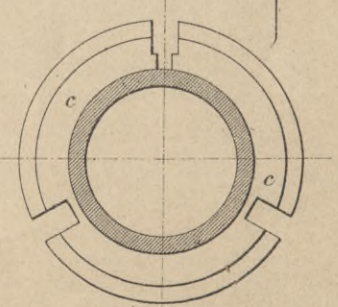
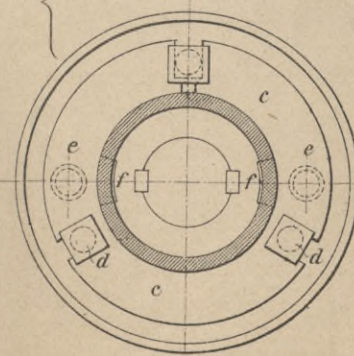


Fig. 169.



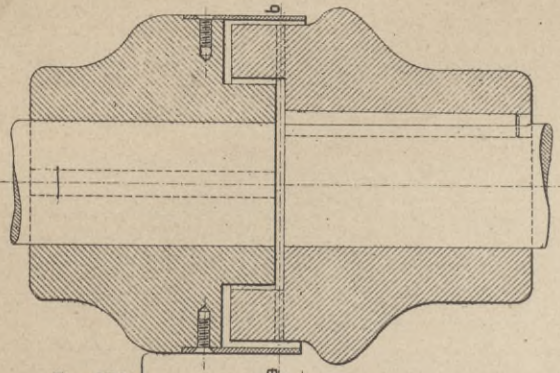
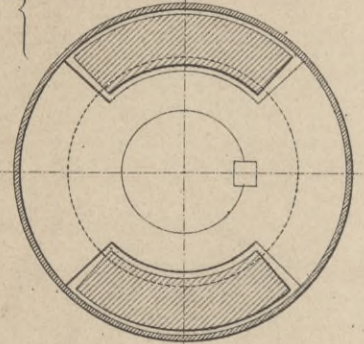


Fig. 170.
1:5



Schnitt: a b.

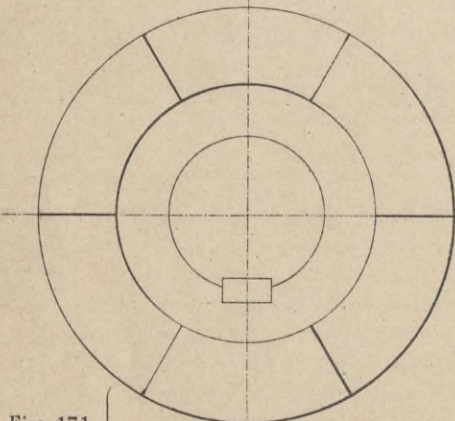


Fig. 171.
2:5

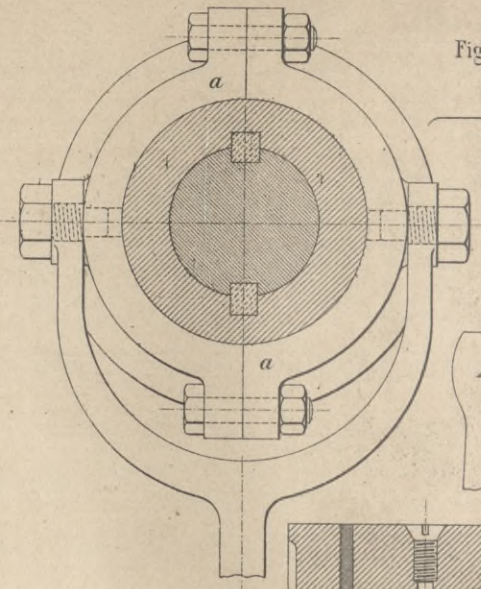
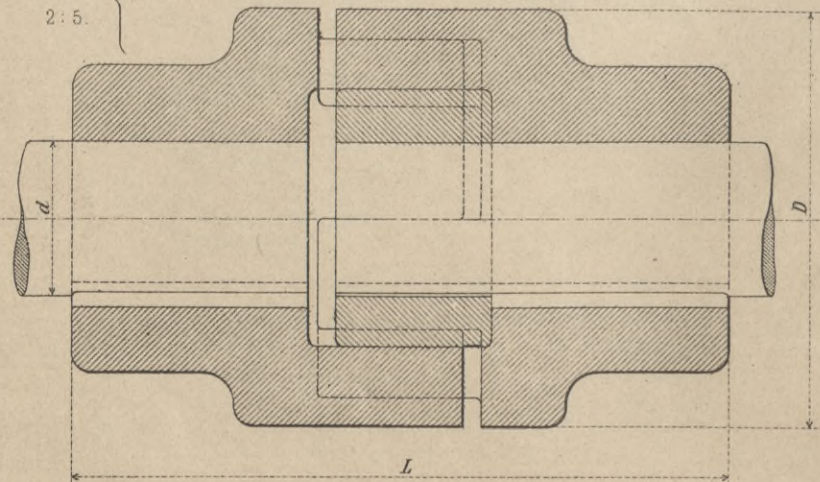


Fig. 174.
1:5

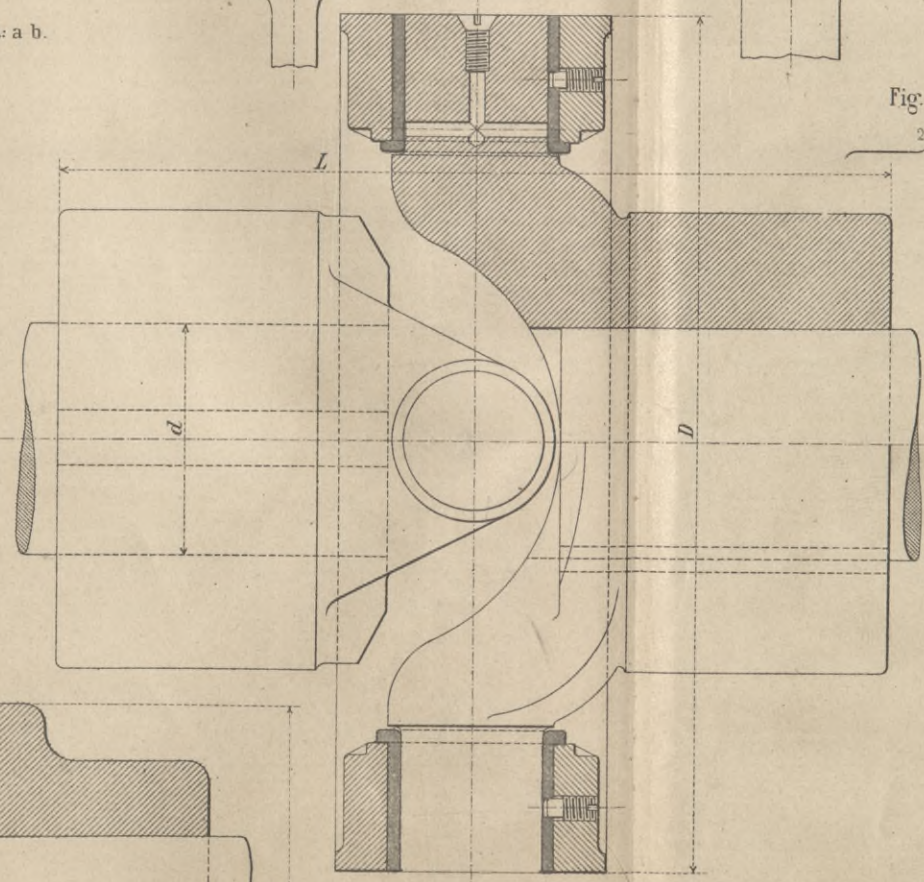
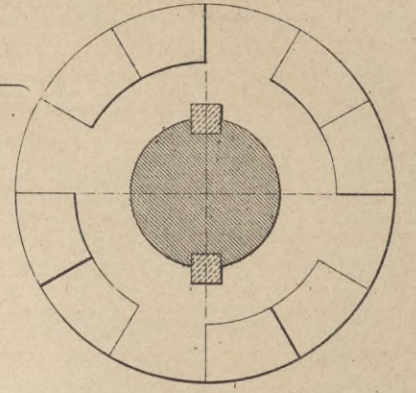
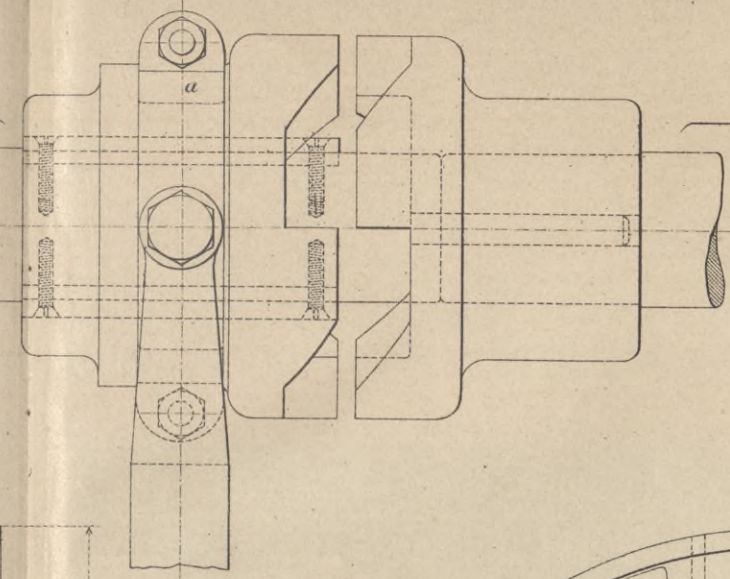
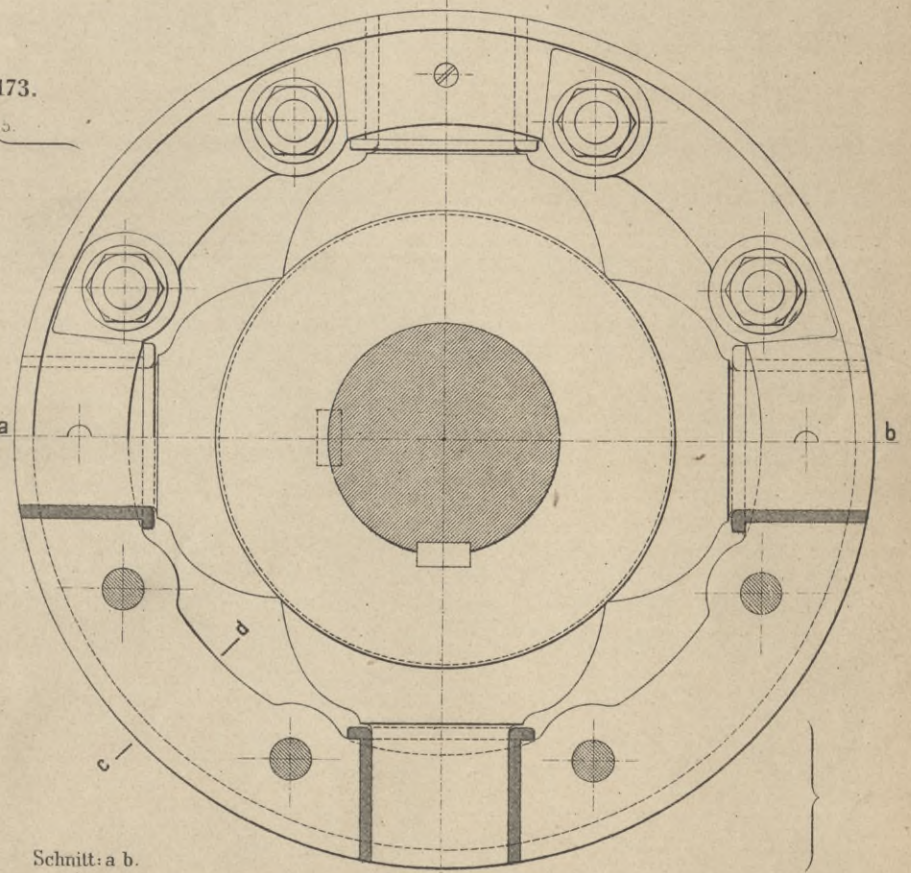
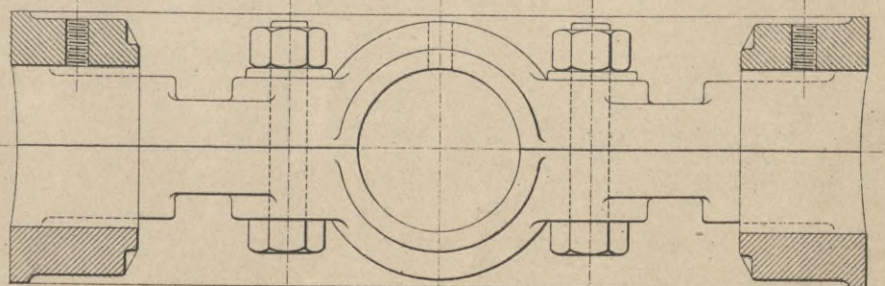
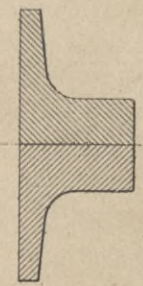


Fig. 173.
2:5



Schnitt: a b.

Schnitt: c d.



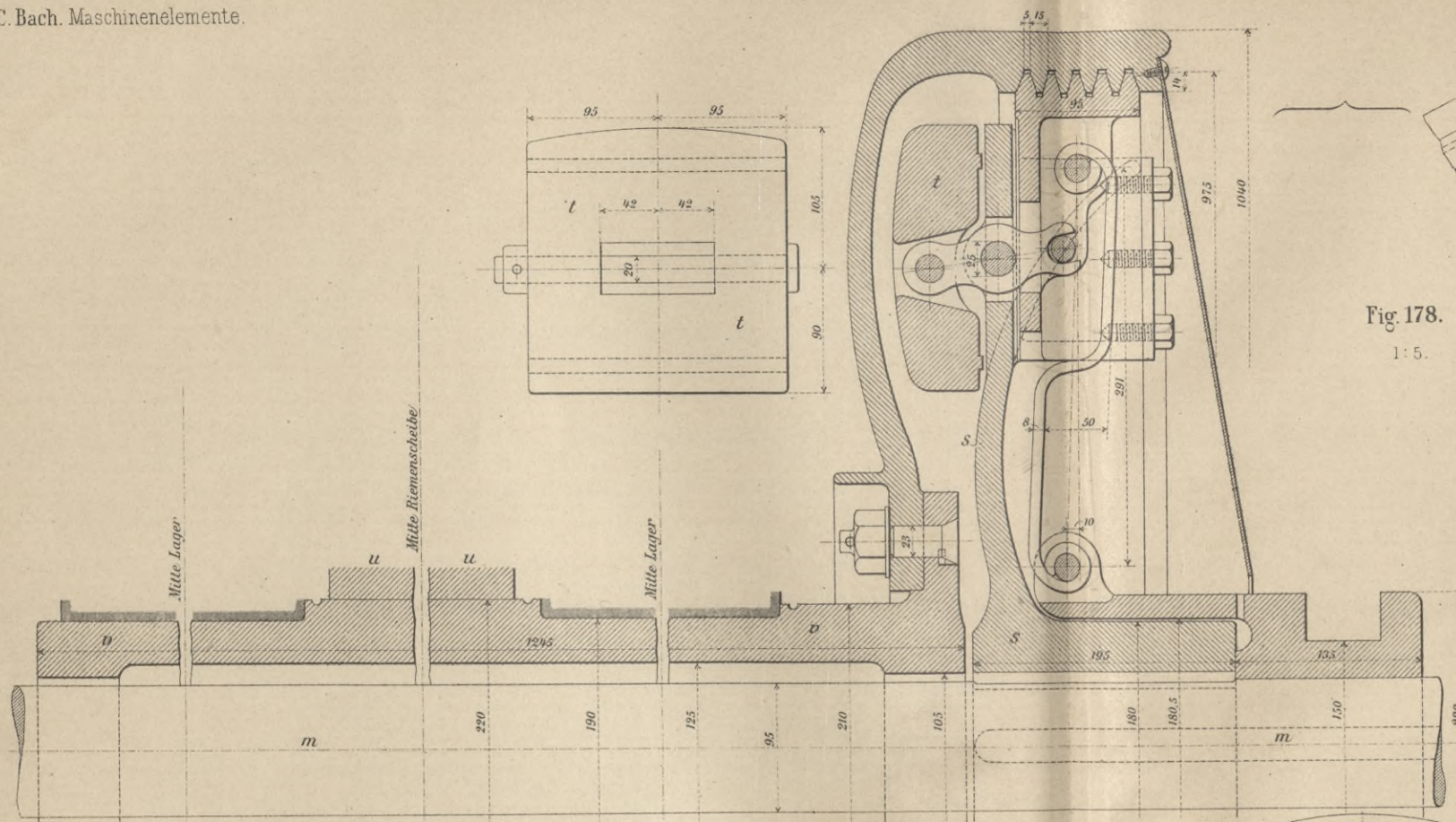
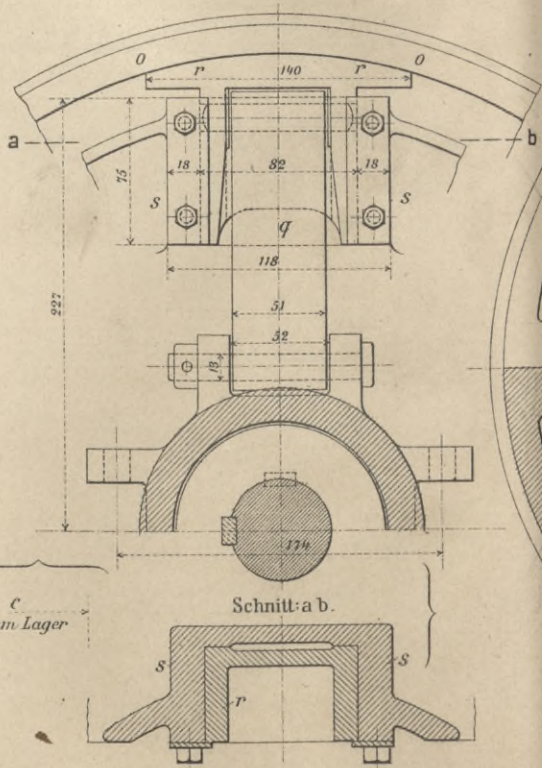
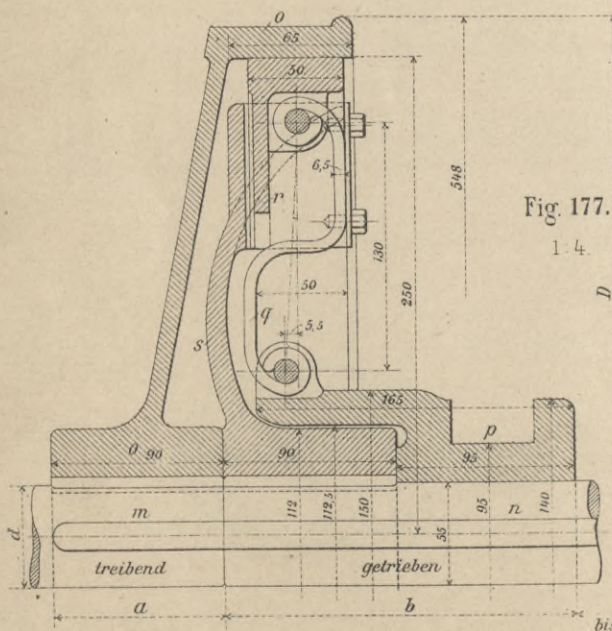


Fig. 177.
1:4.



Schnitt: a b.

Schnitt: c d.

Fig. 178.
1:5.

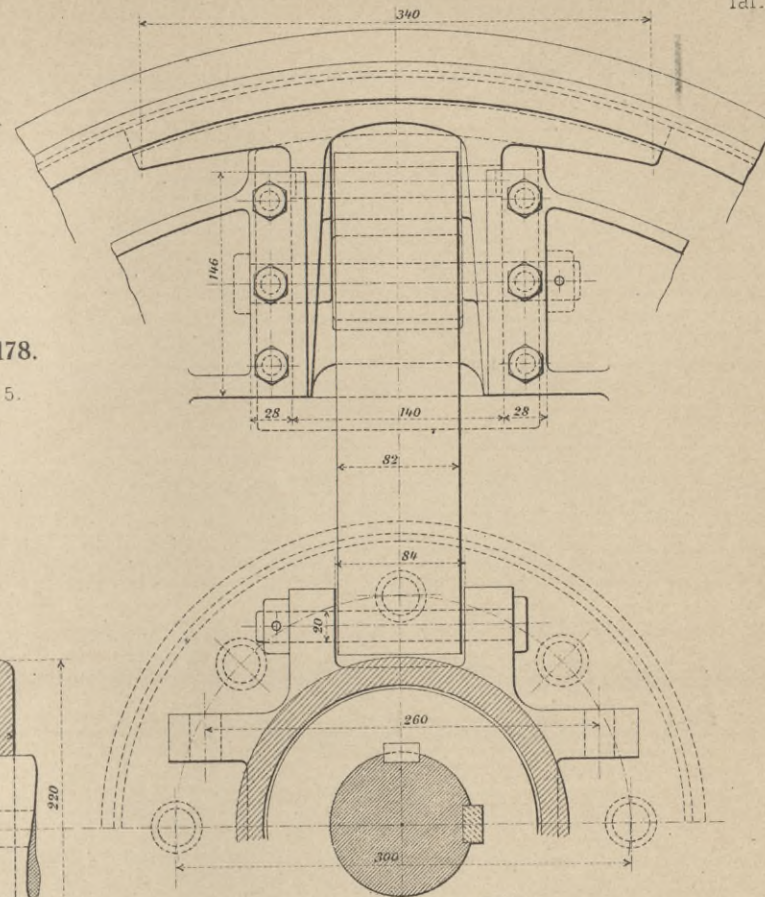
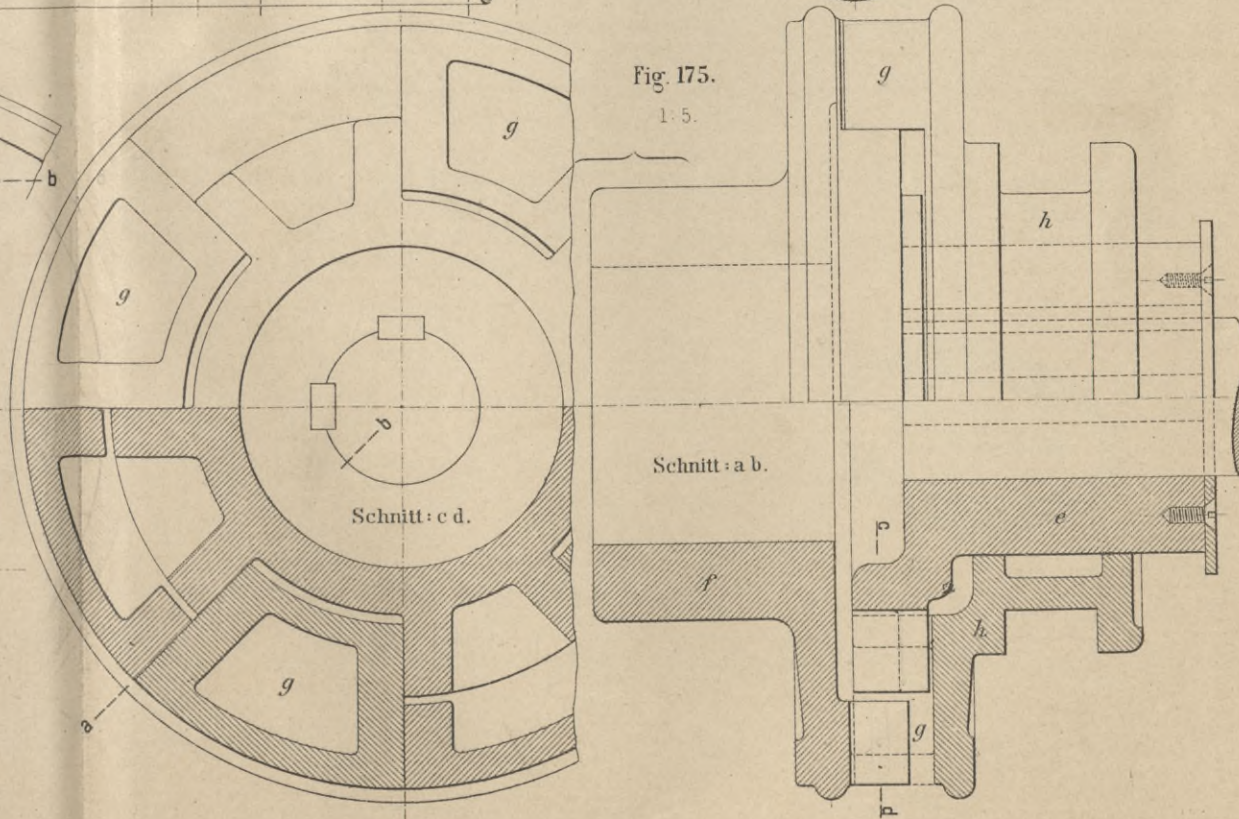


Fig. 175.
1:5.



Schnitt: a b.



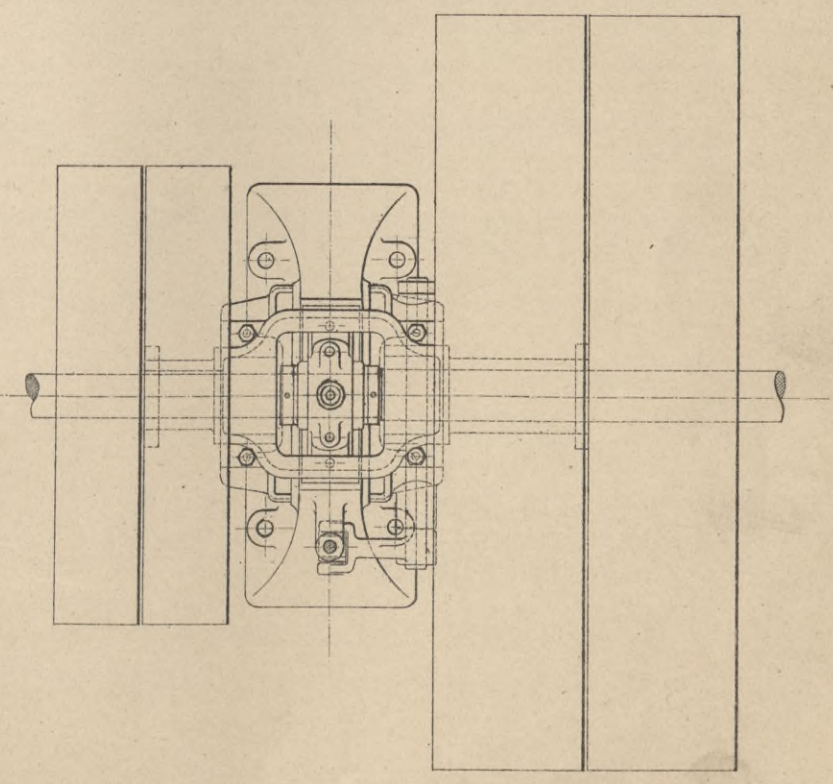
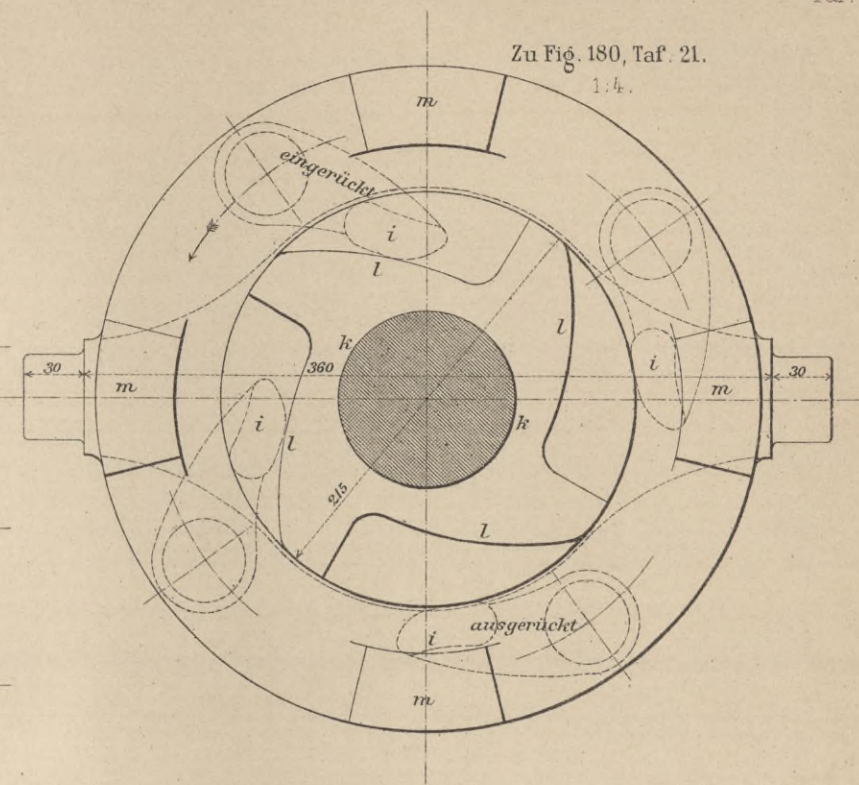
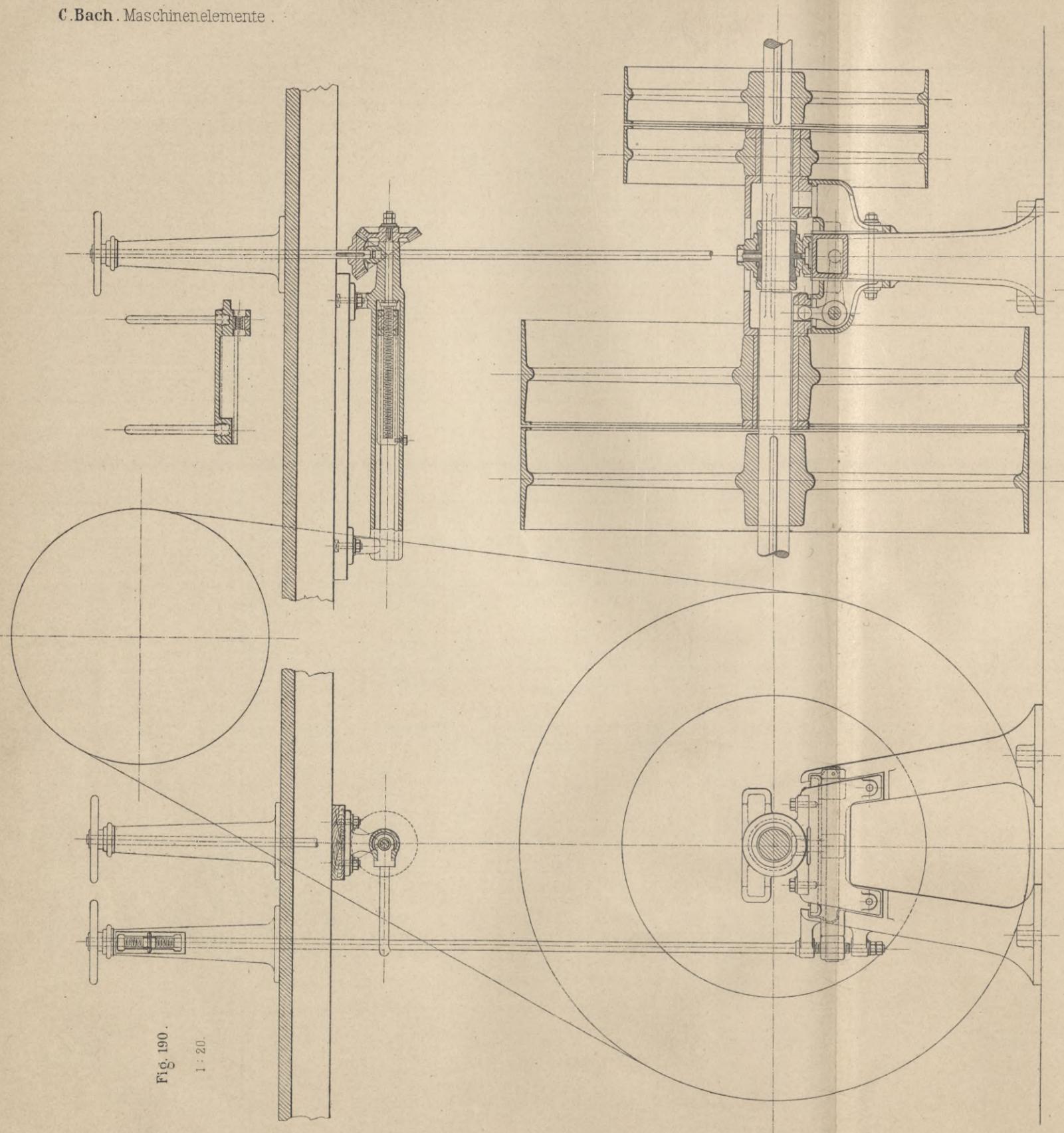


Fig. 181.

1:4.

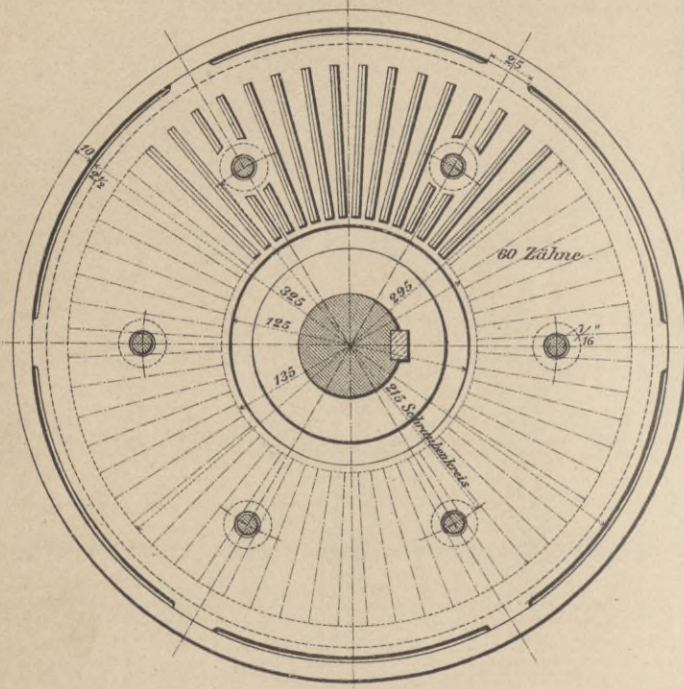


Fig. 185.

Rückansicht der Zahnscheibe.

1:4.

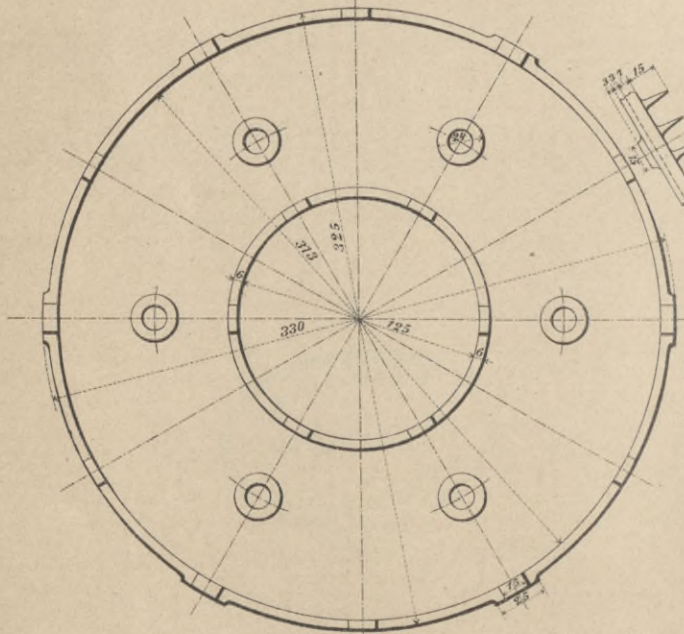


Fig. 182.

2:1.

1:4.

1:4.

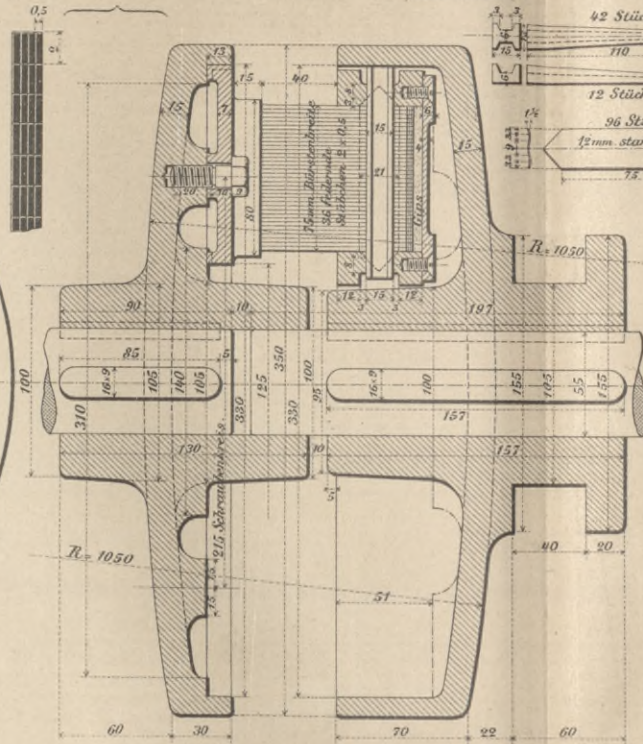


Fig. 186.

Kupplungshälfte für die Bürstenscheibe.

1:4.

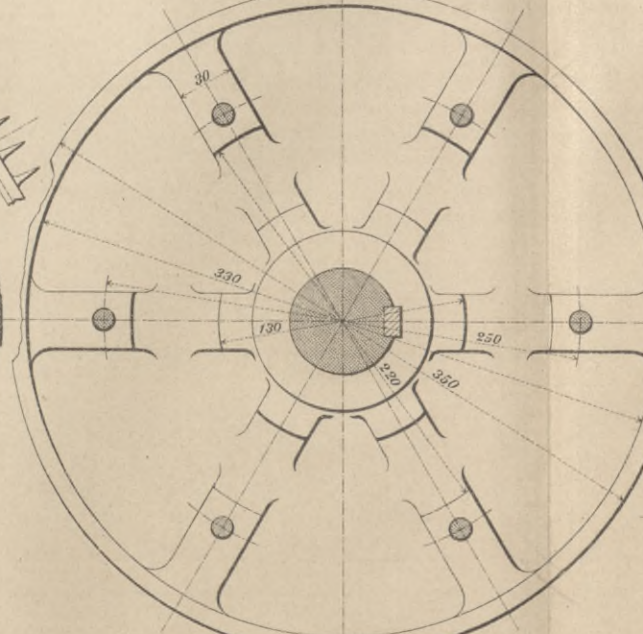


Fig. 183.

1:4.

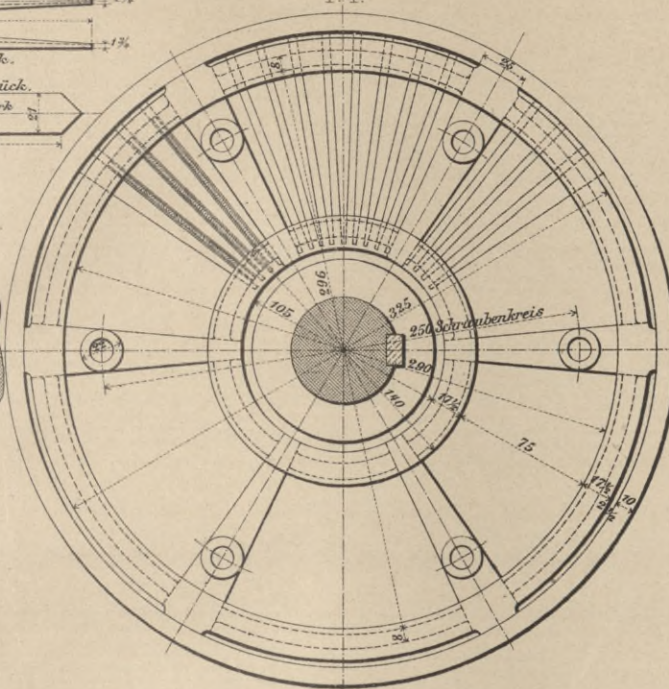
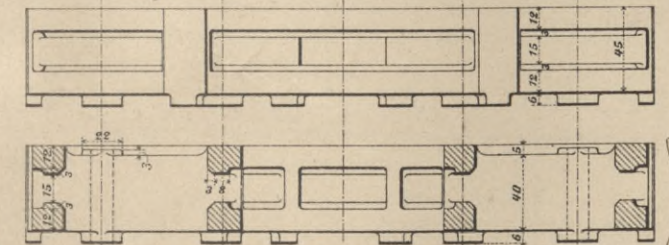


Fig. 187.

1:4.



Rückansicht der Bürstenscheibe.

1:4.

Fig. 188.

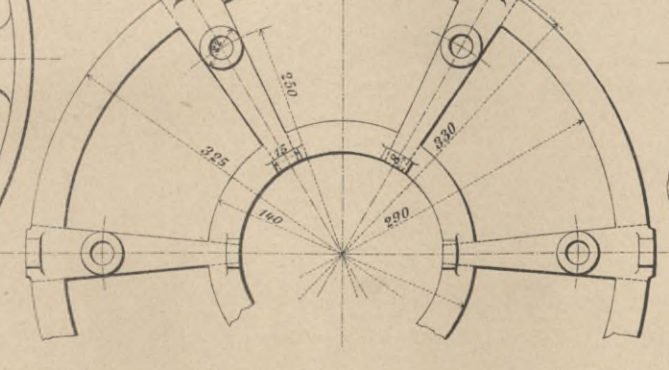


Fig. 184.

Kupplungshälfte für die Zahnscheibe.

1:4.

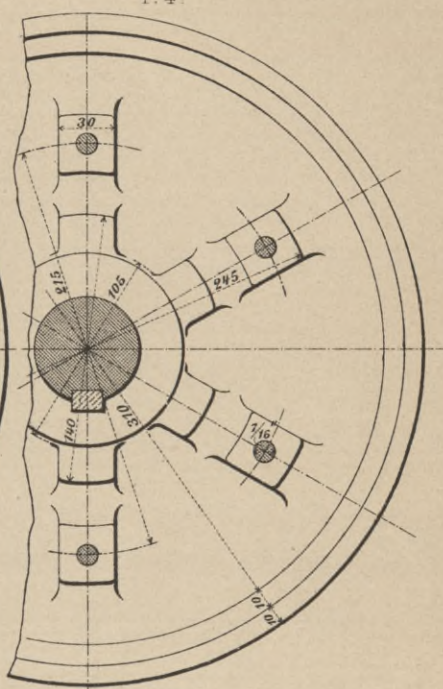
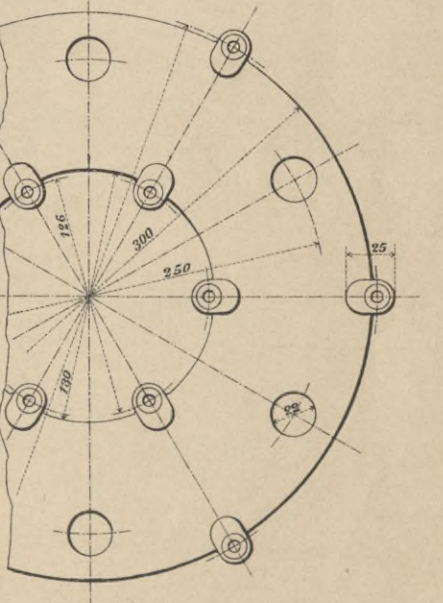


Fig. 189.

1:4.



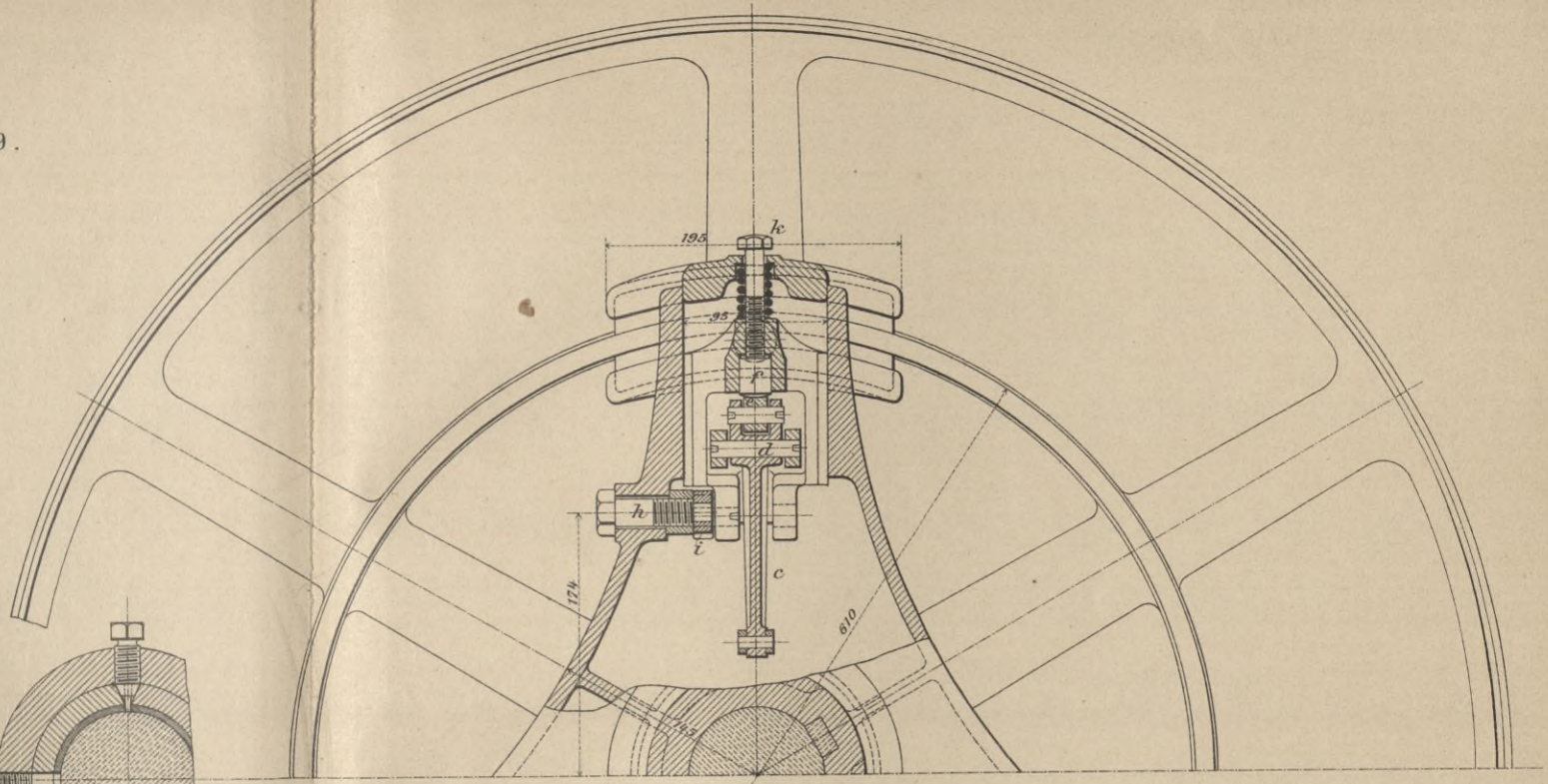
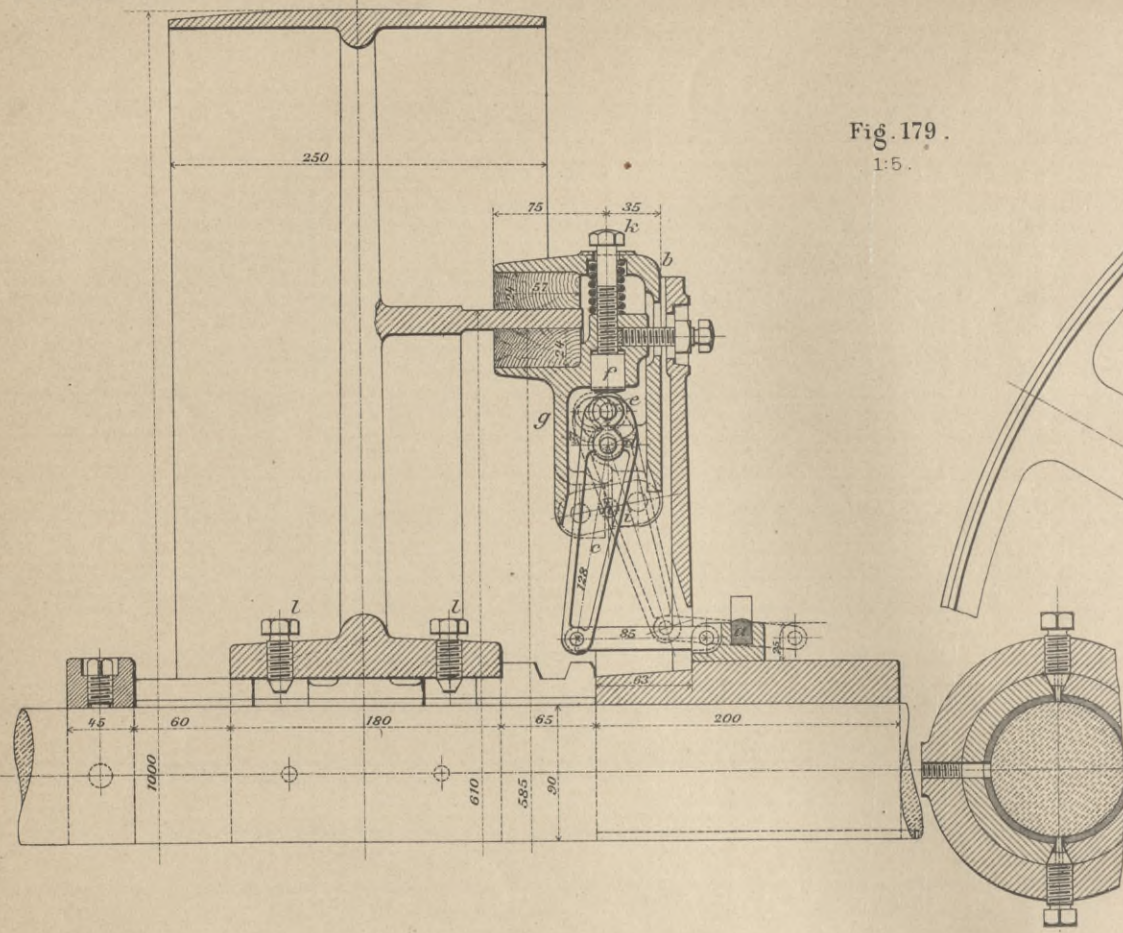


Fig. 172.
1:5.

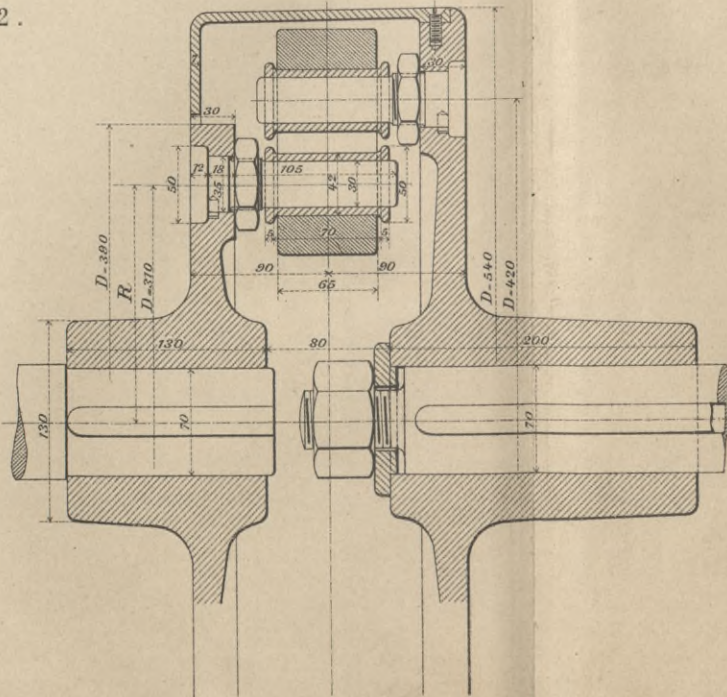
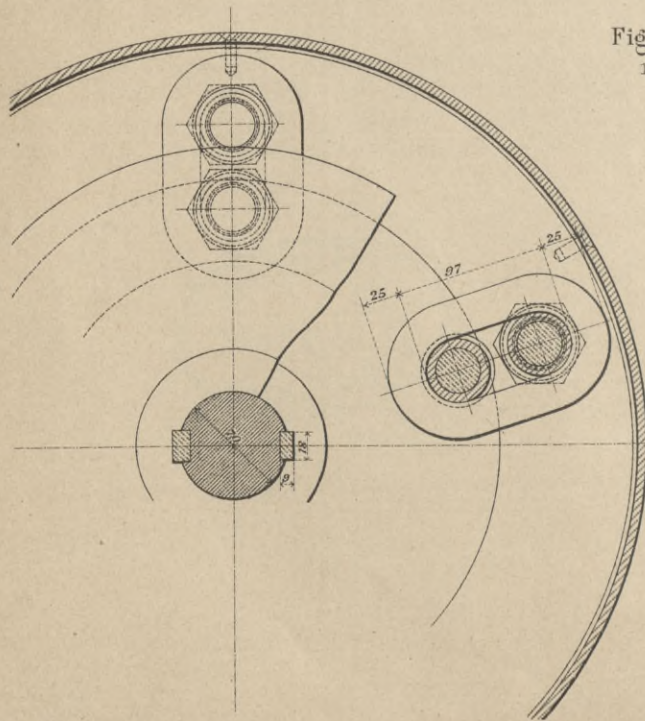
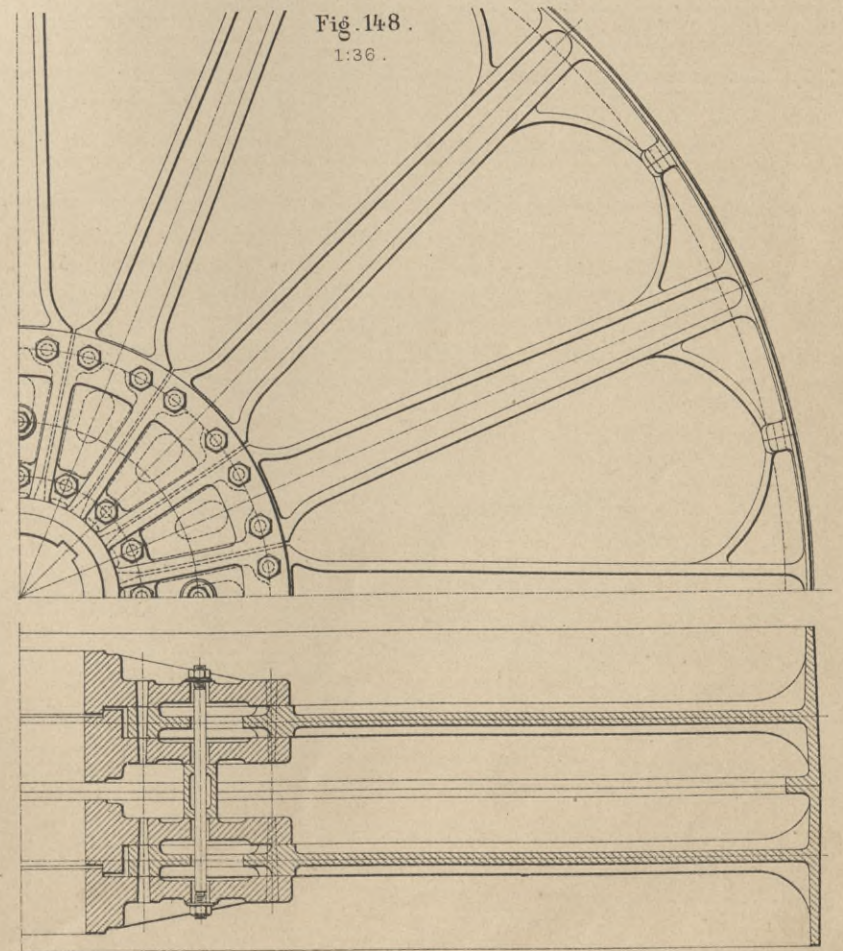


Fig. 148.
1:36.



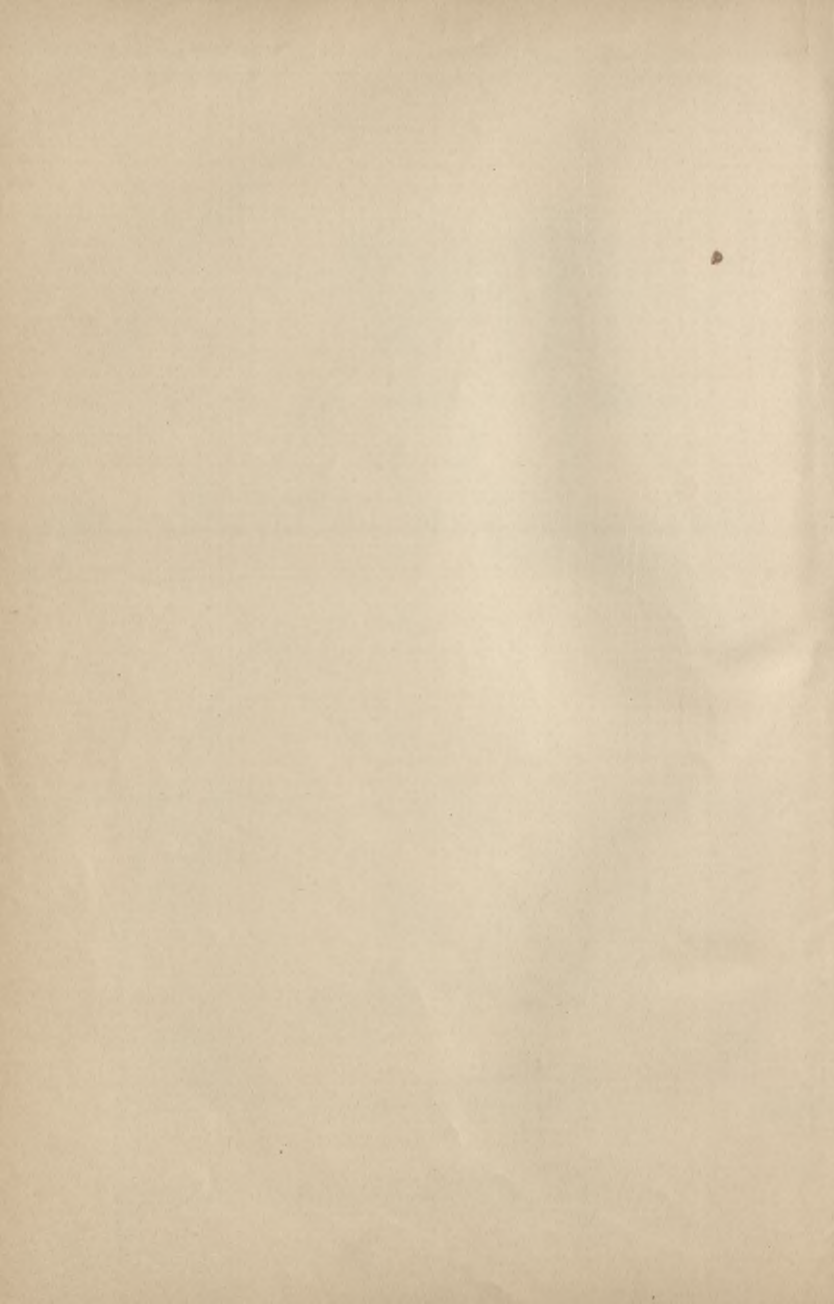


Fig. 191.

1:4.

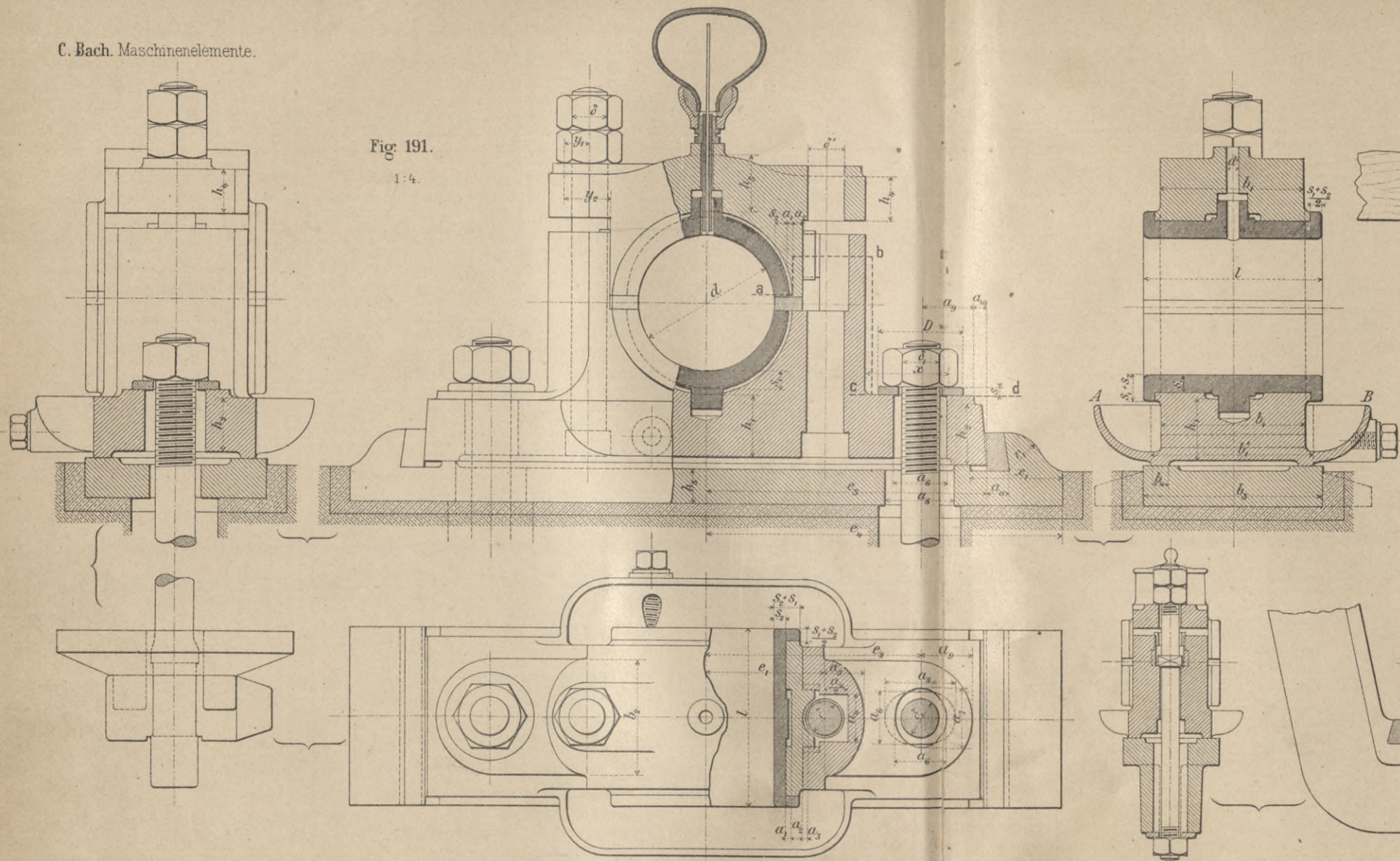


Fig. 192.

1:5.

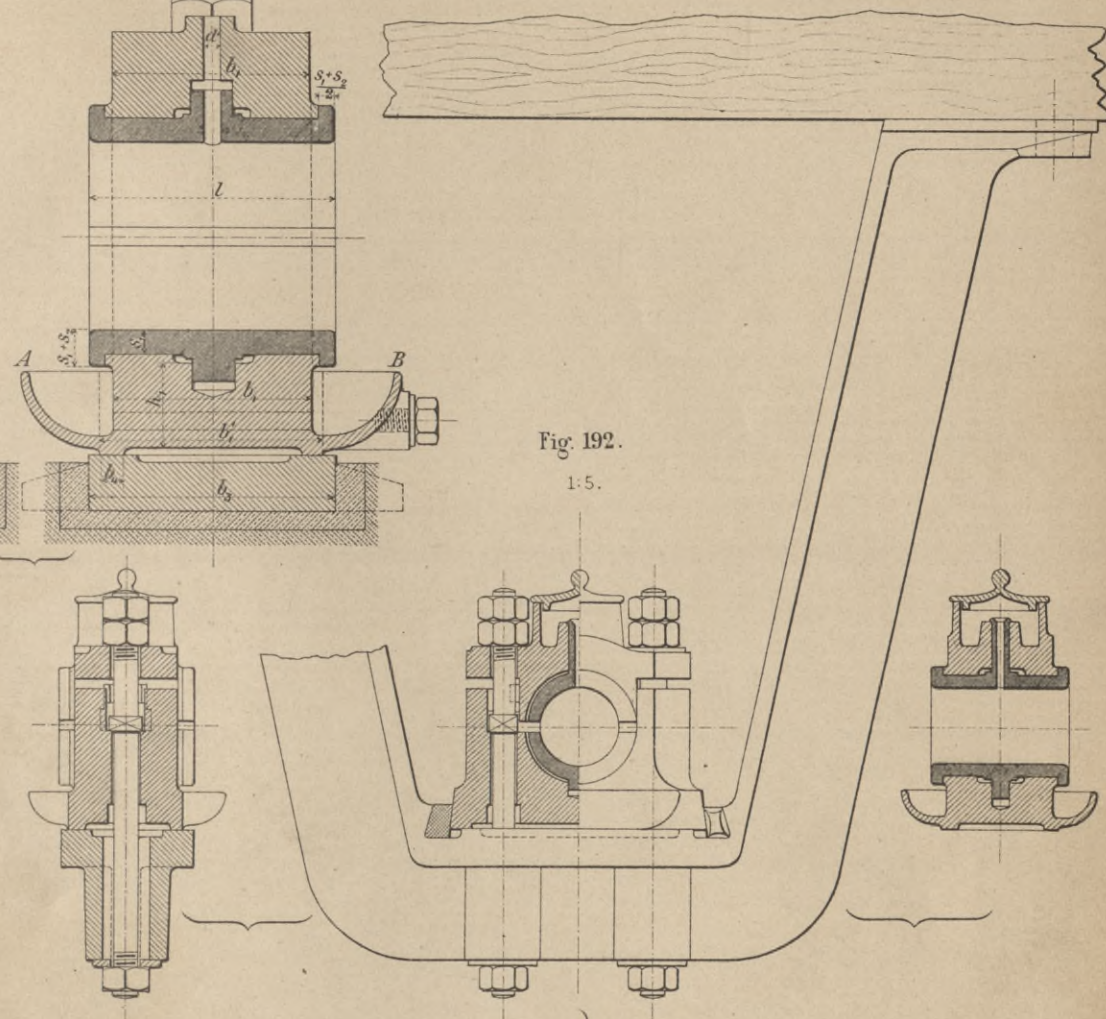
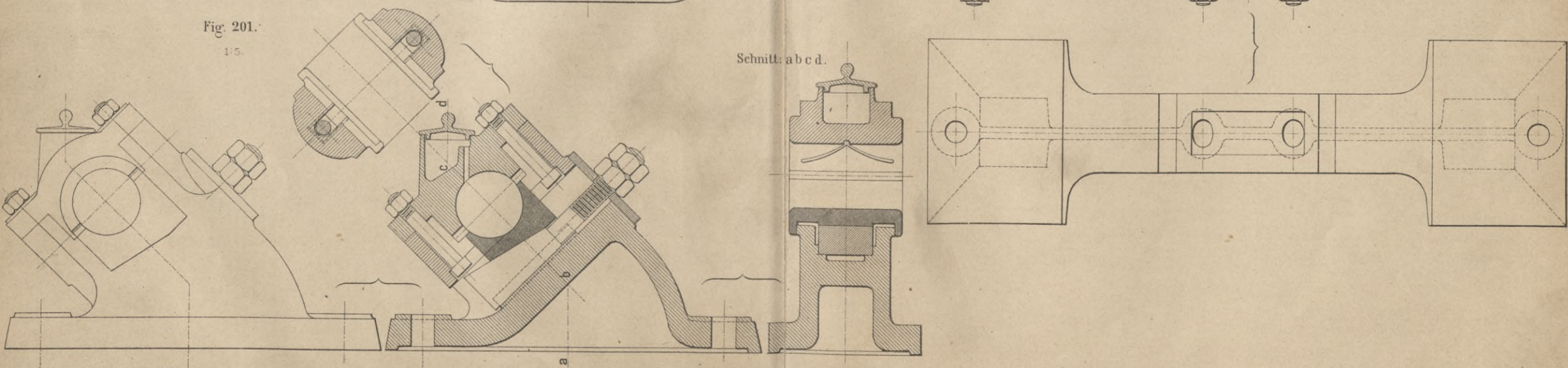


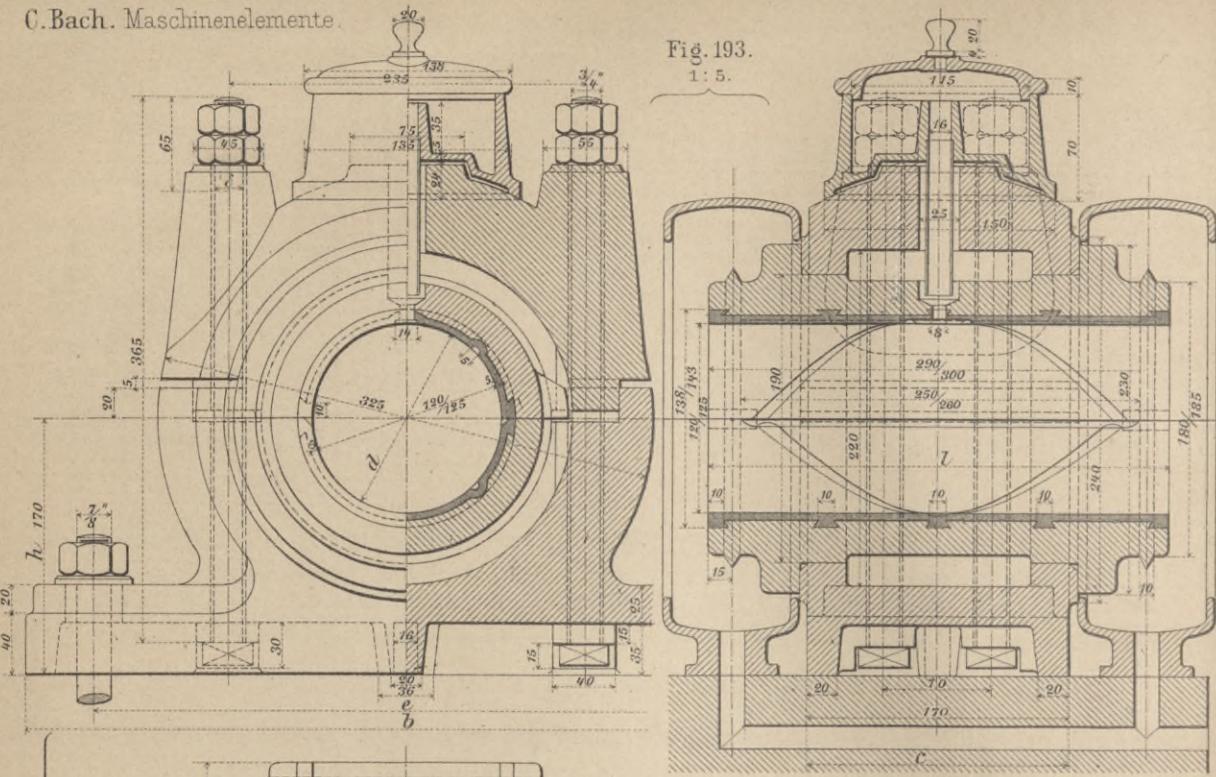
Fig. 201.

1:5.



Schnitt: a b c d.

Fig. 193.
1:5.



Schnitt a-b.

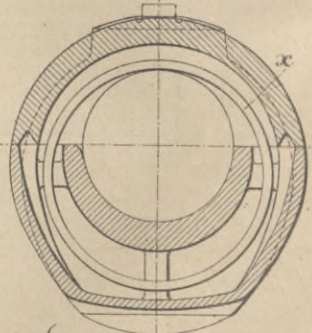


Fig. 203.
1:8.

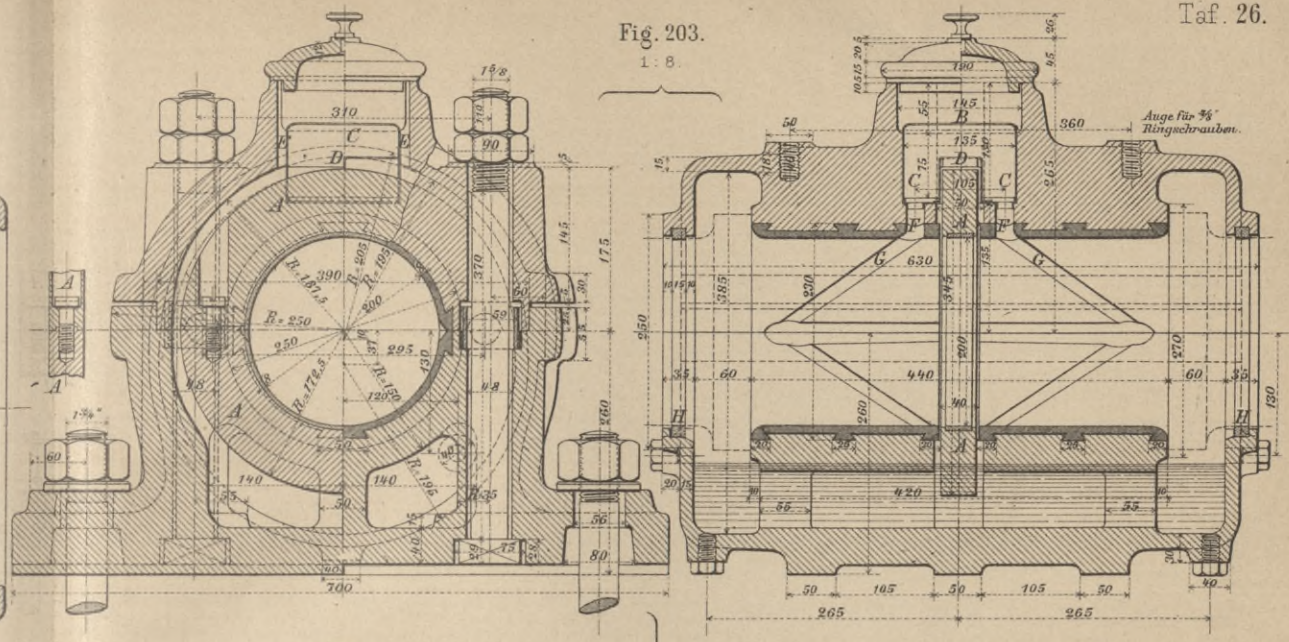


Fig. 202.
1:4.

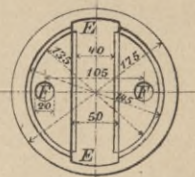
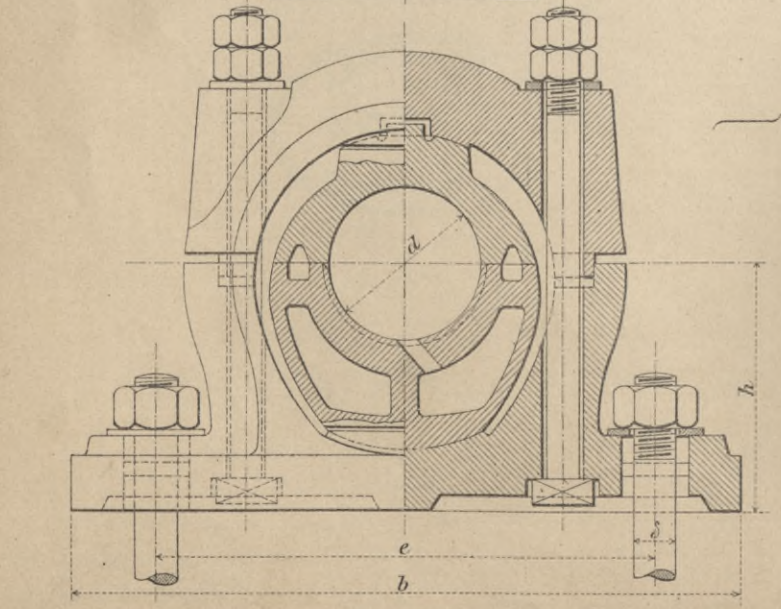
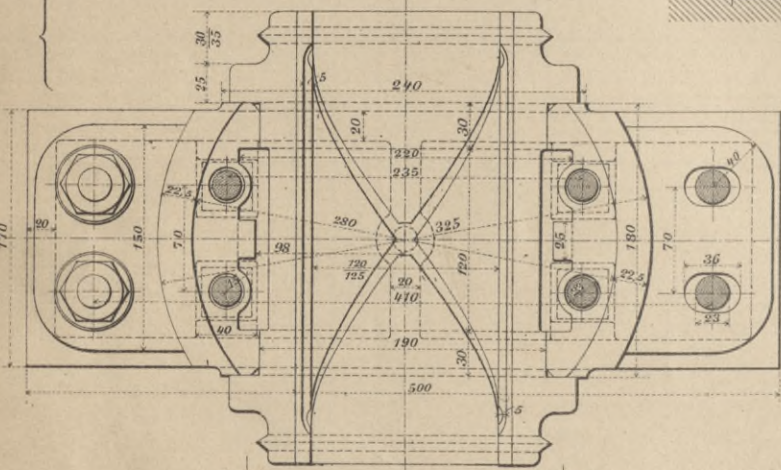
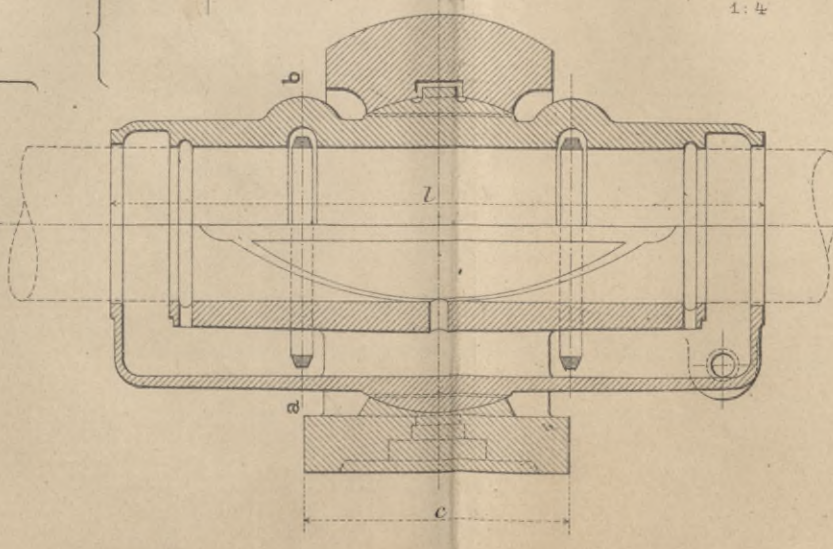


Fig. 194.

2:5.

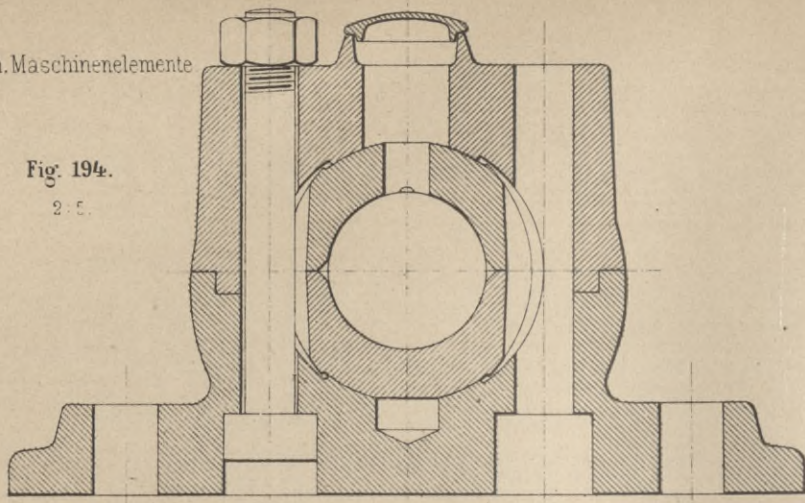


Fig. 195.

1:4

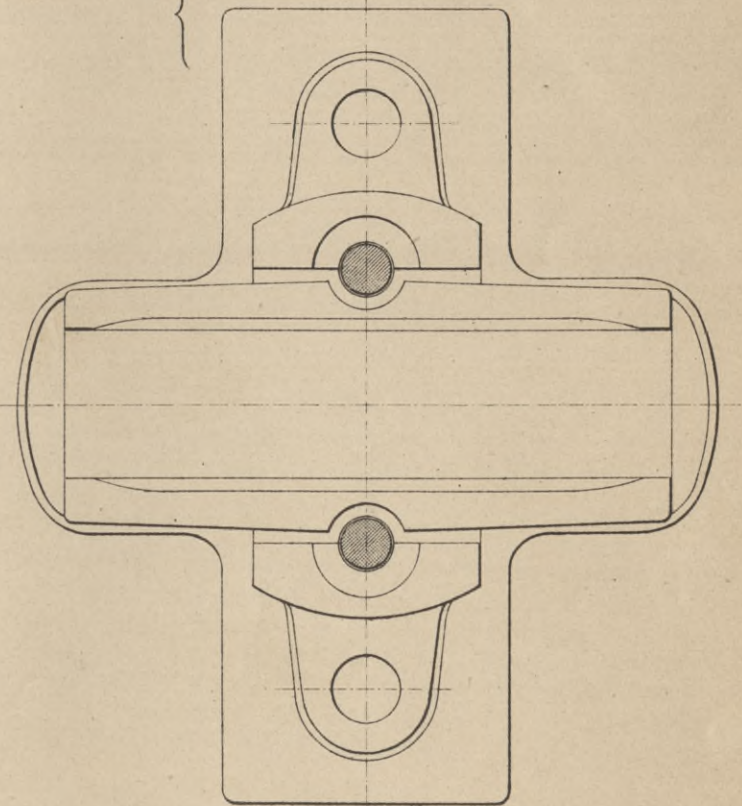
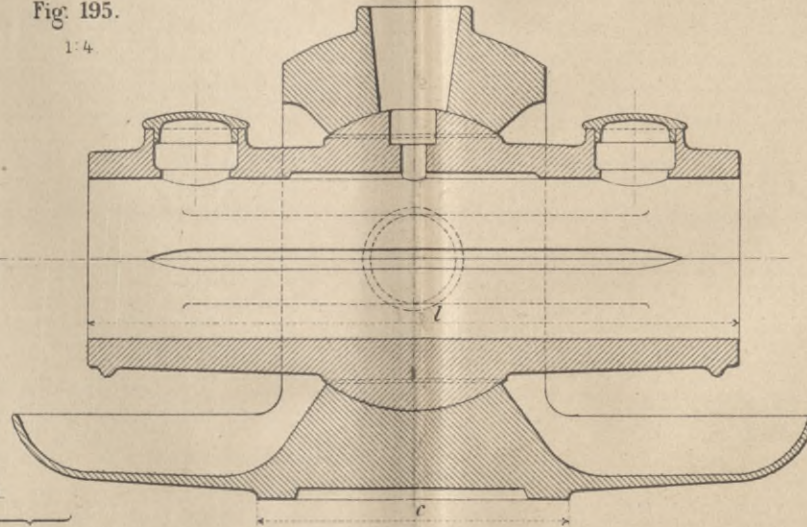
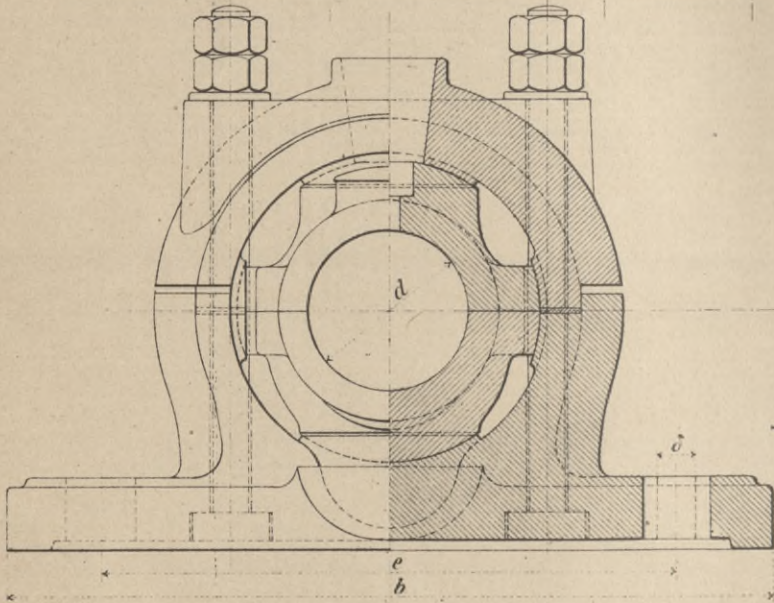
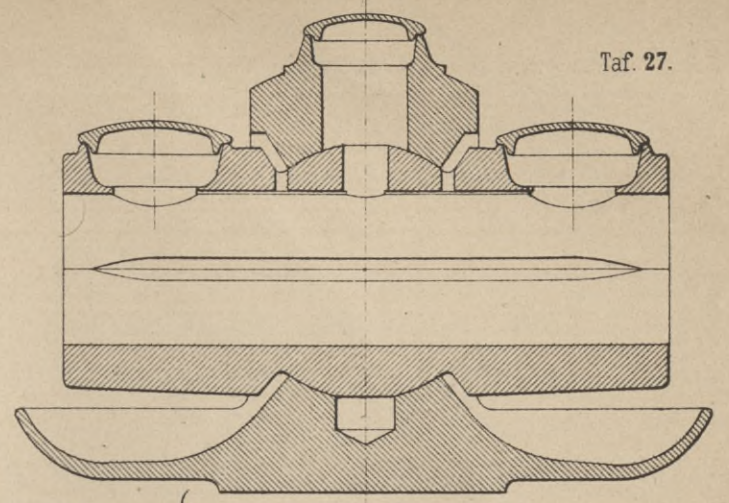
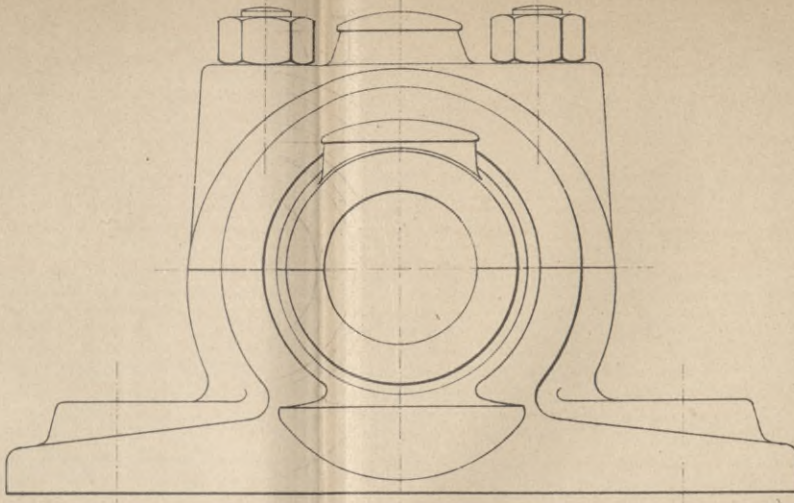
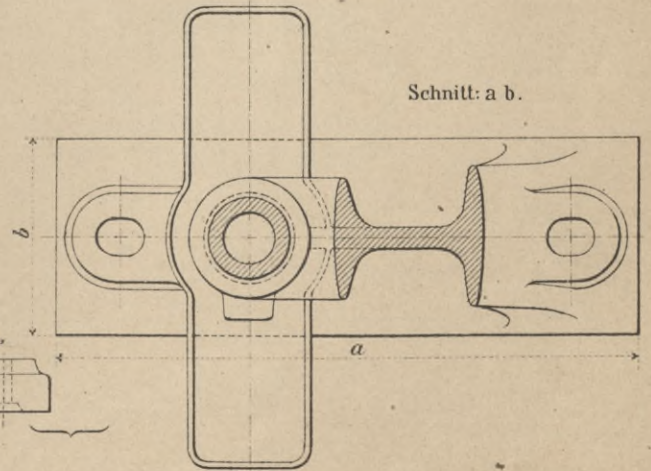
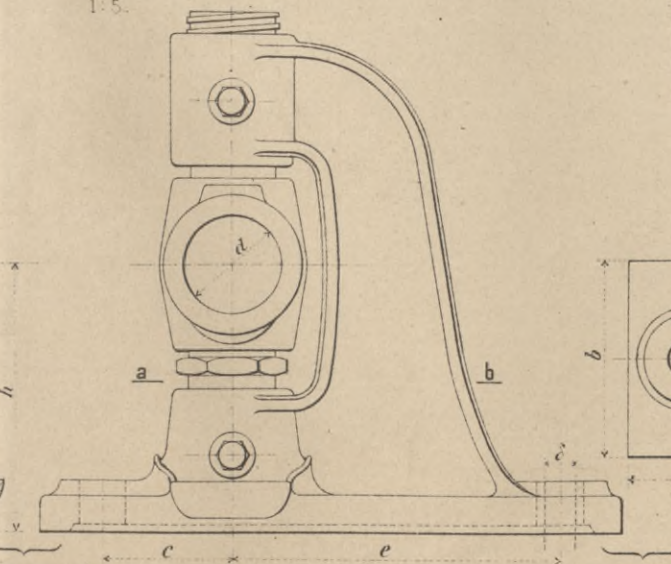
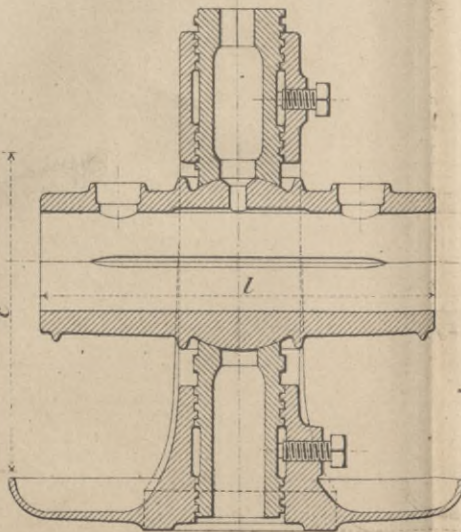
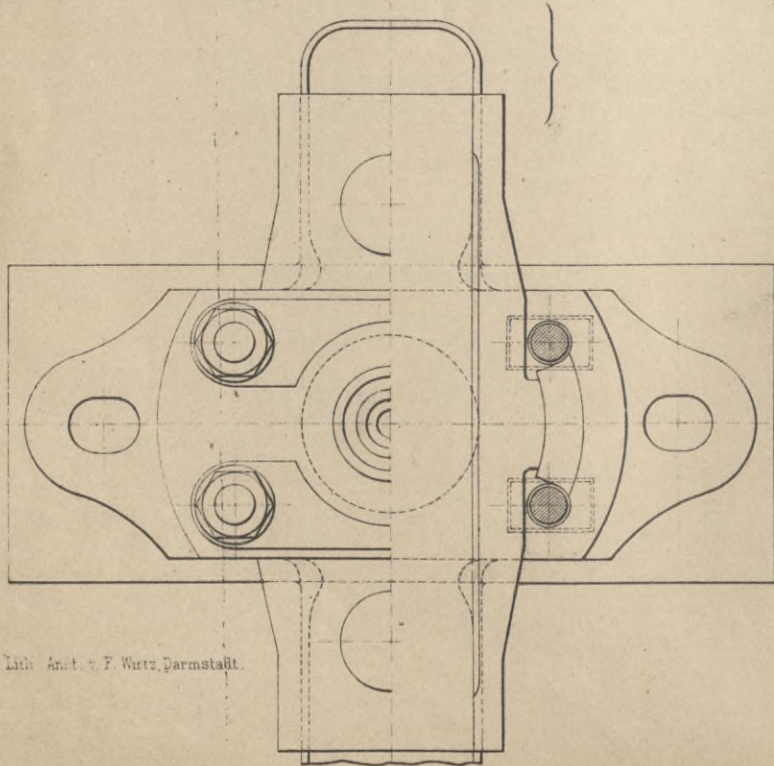


Fig. 196.

1:5.



Schnitt: a b.



Fig. 197.
1:5.

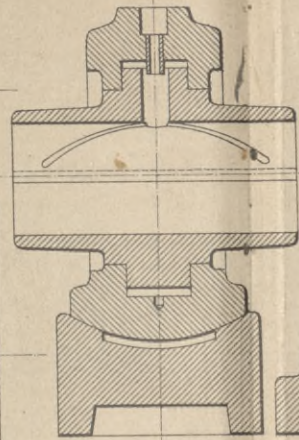
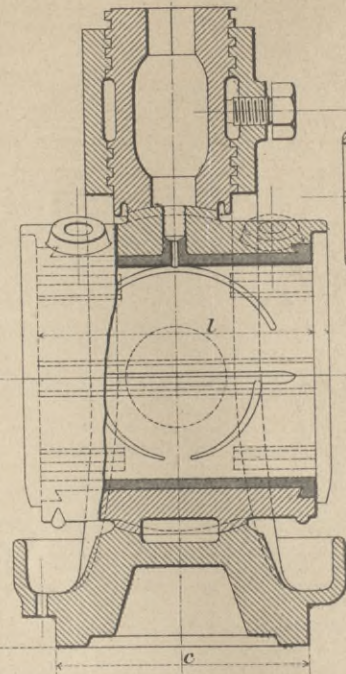
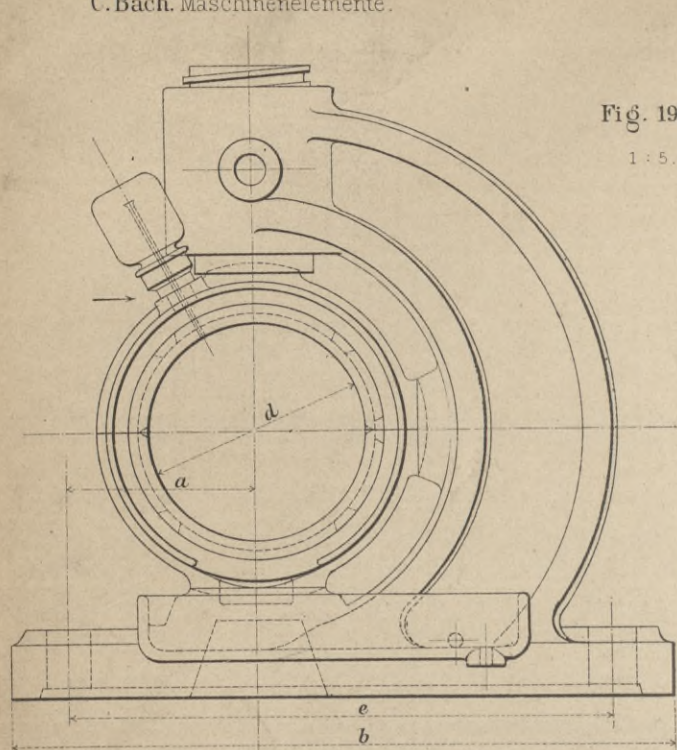


Fig. 198.
1:4.

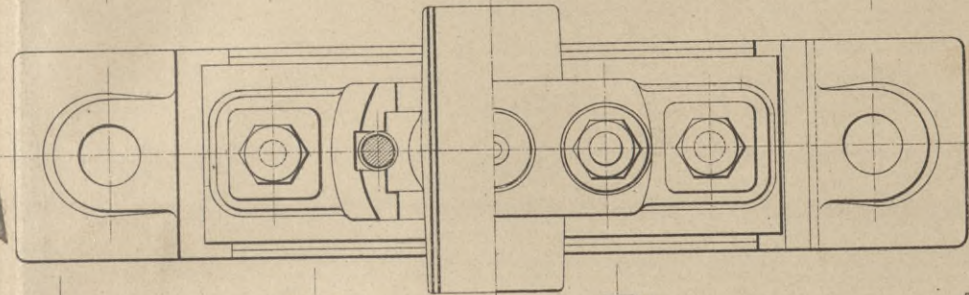
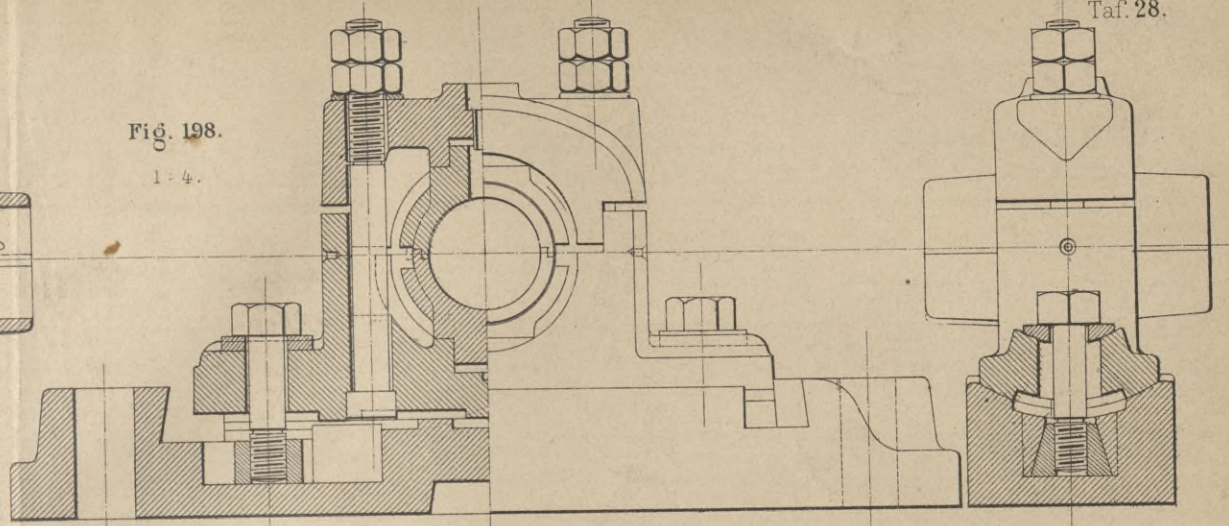


Fig. 205.
1:10.

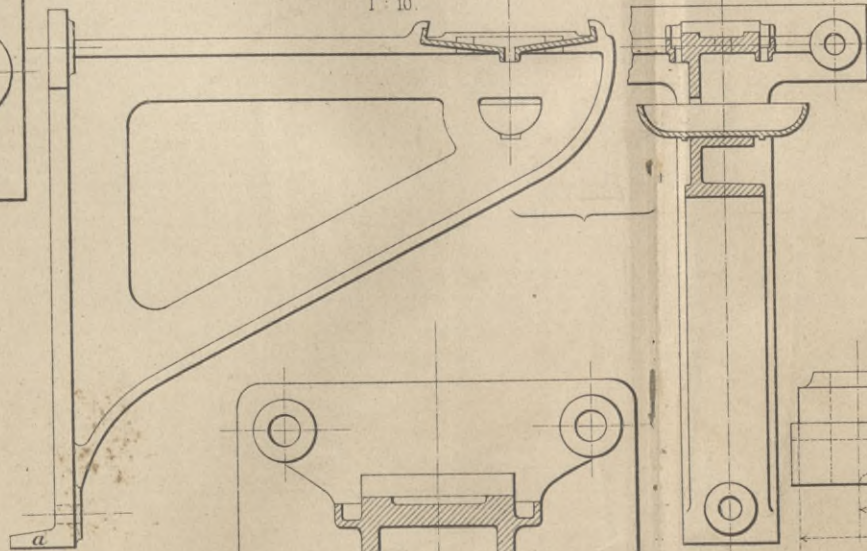


Fig. 206.
1:10.

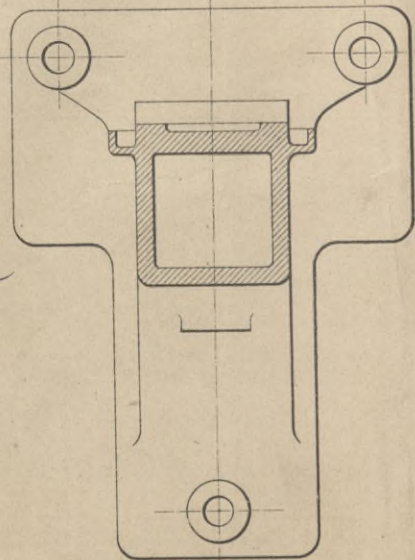
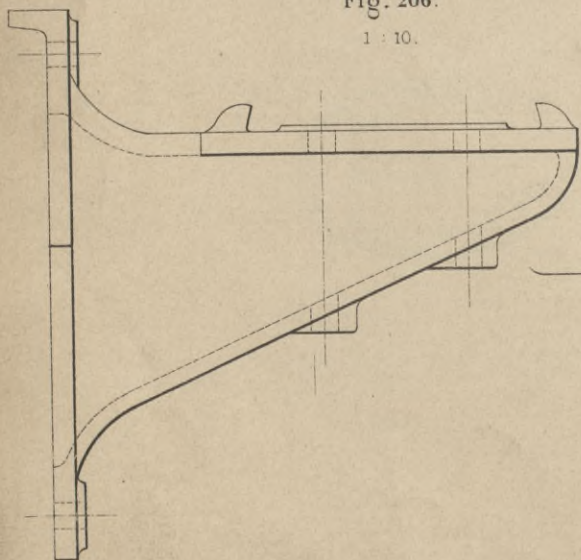


Fig. 199.
1:5.

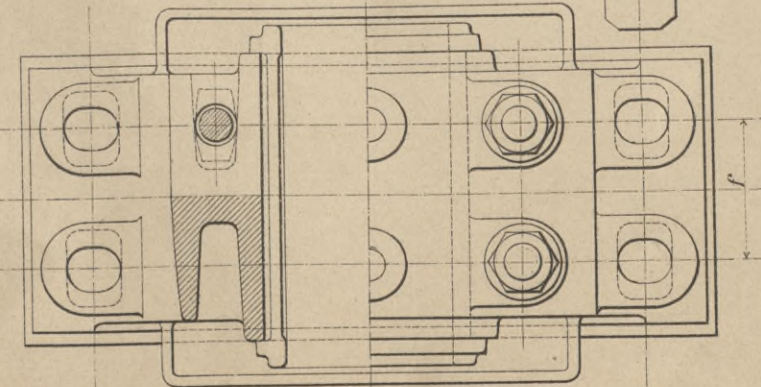
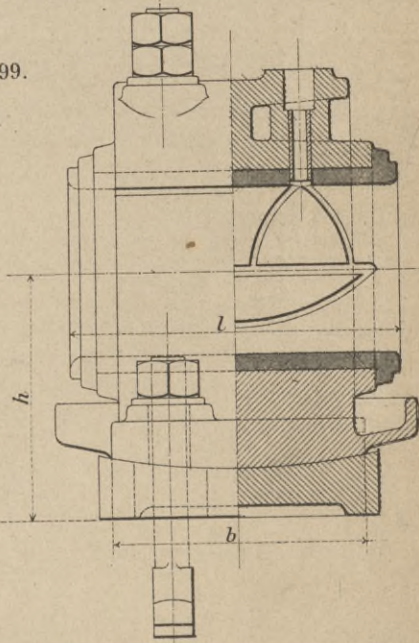
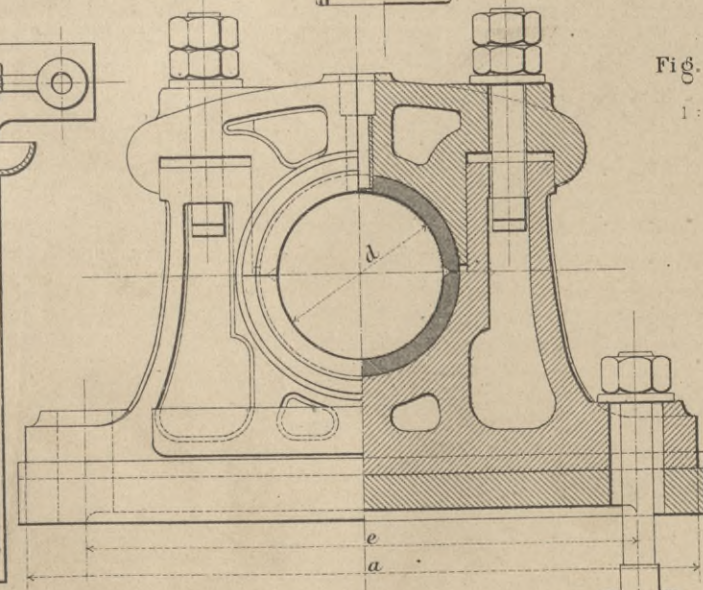




Fig. 200.

1:5.

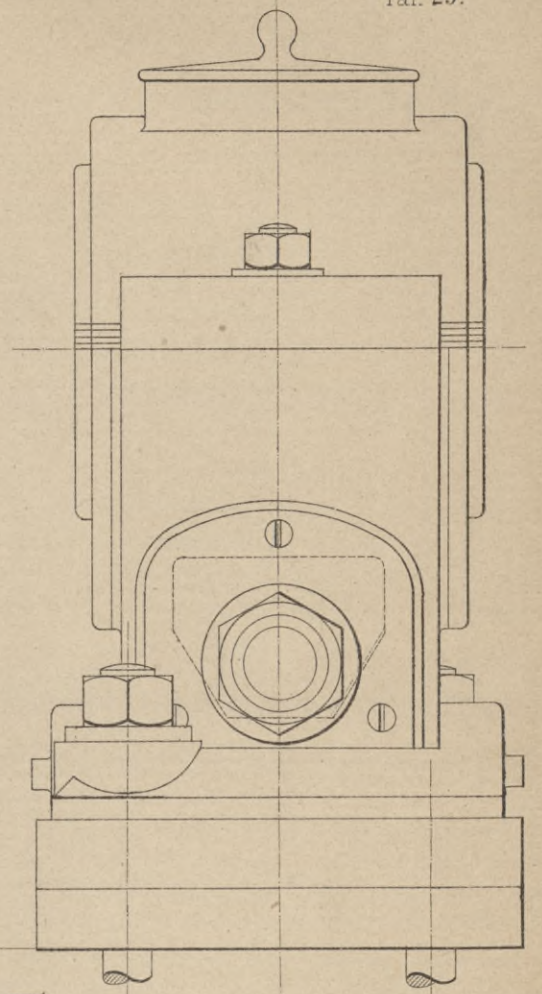
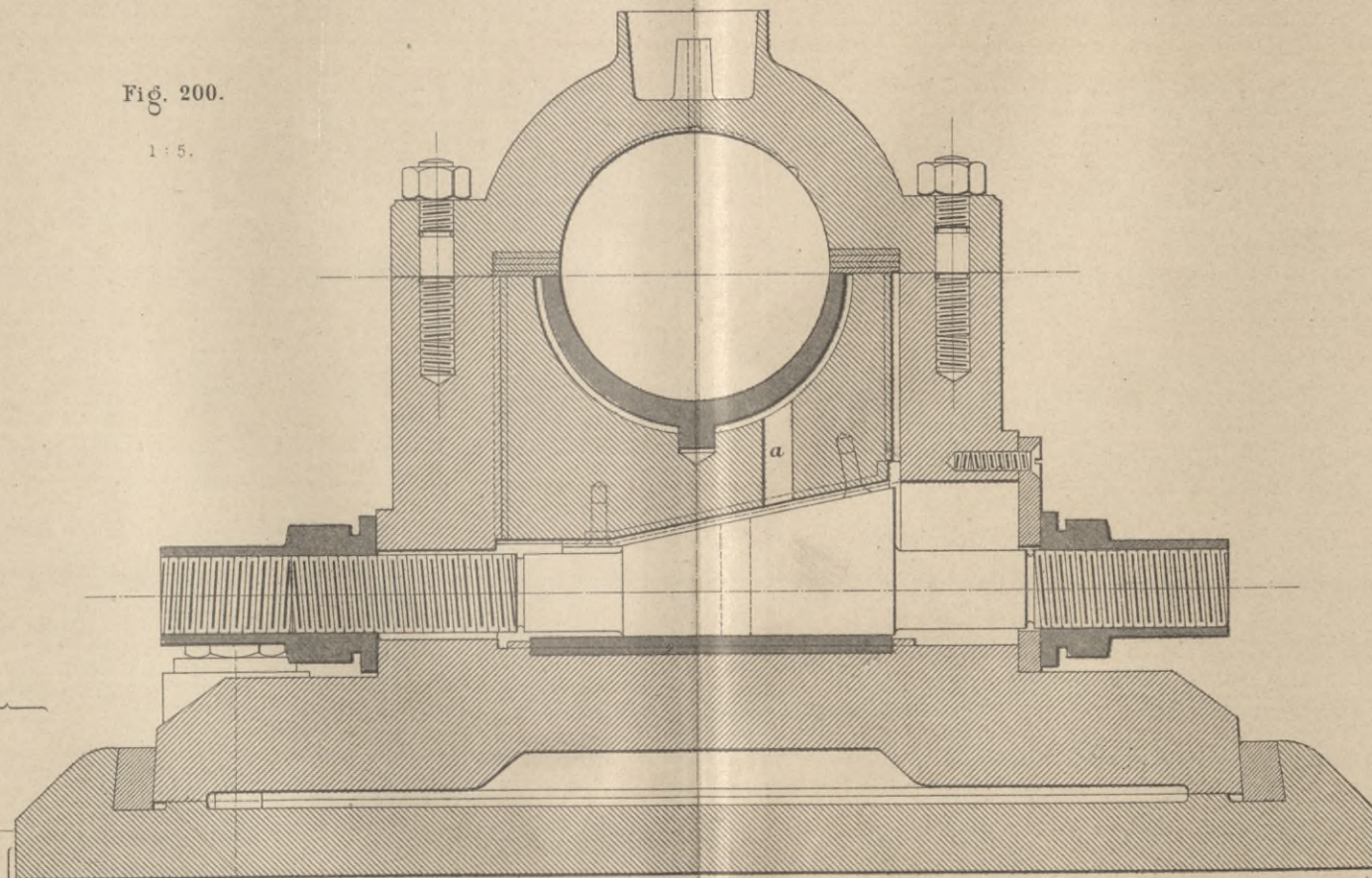
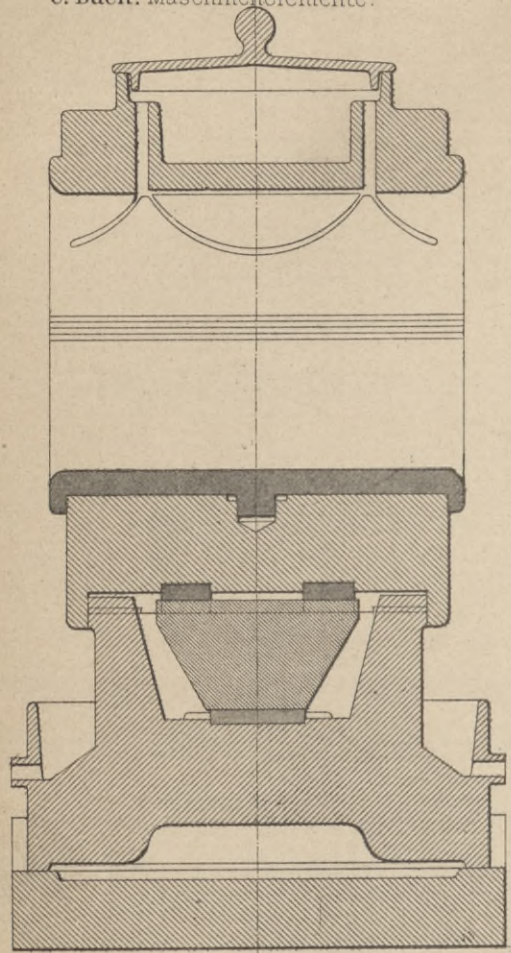


Fig. 213.

1:10.

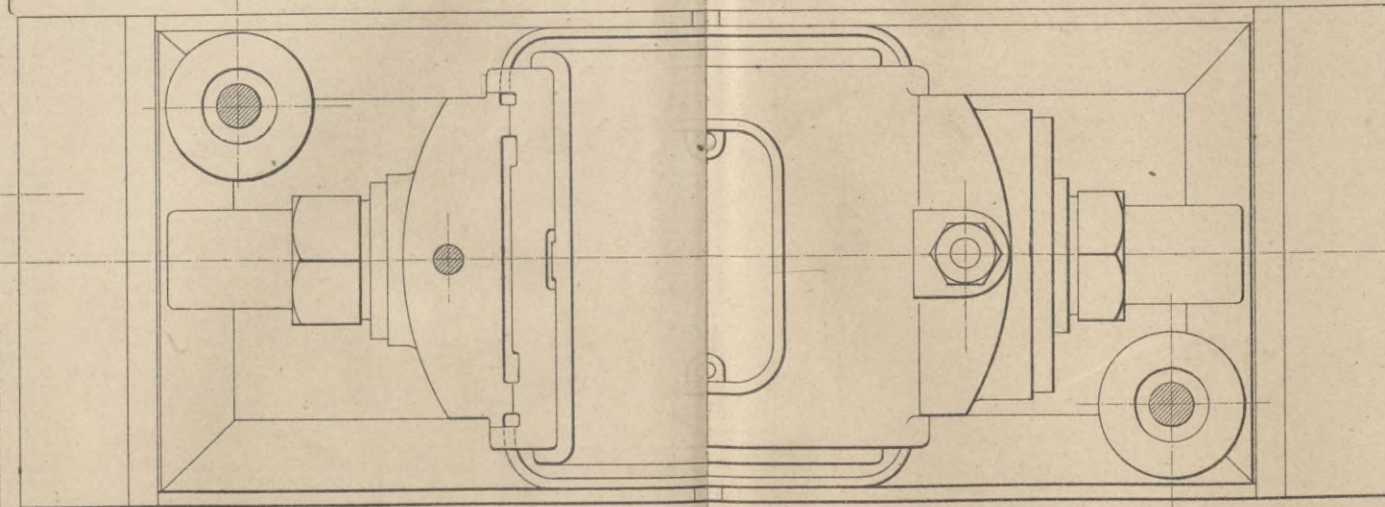
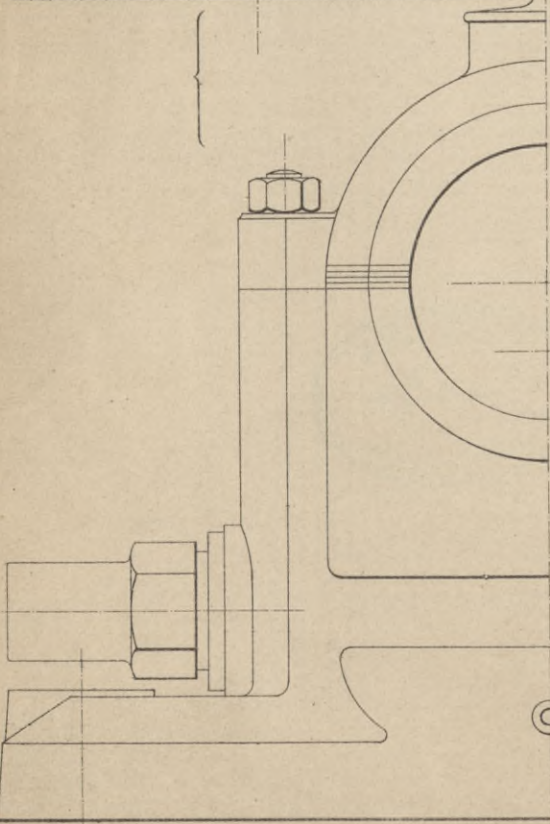
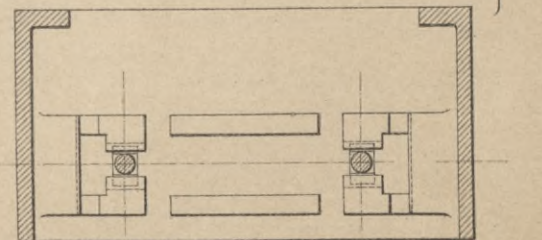
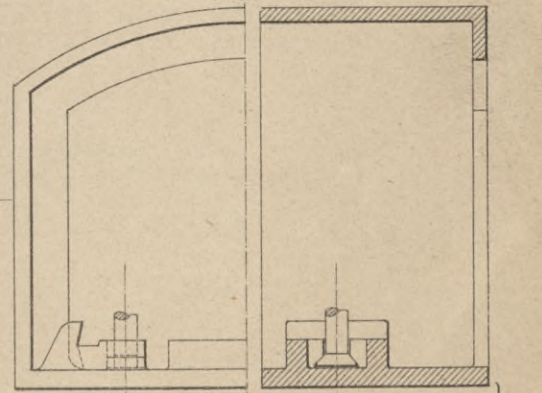


Fig. 207.

1:8.

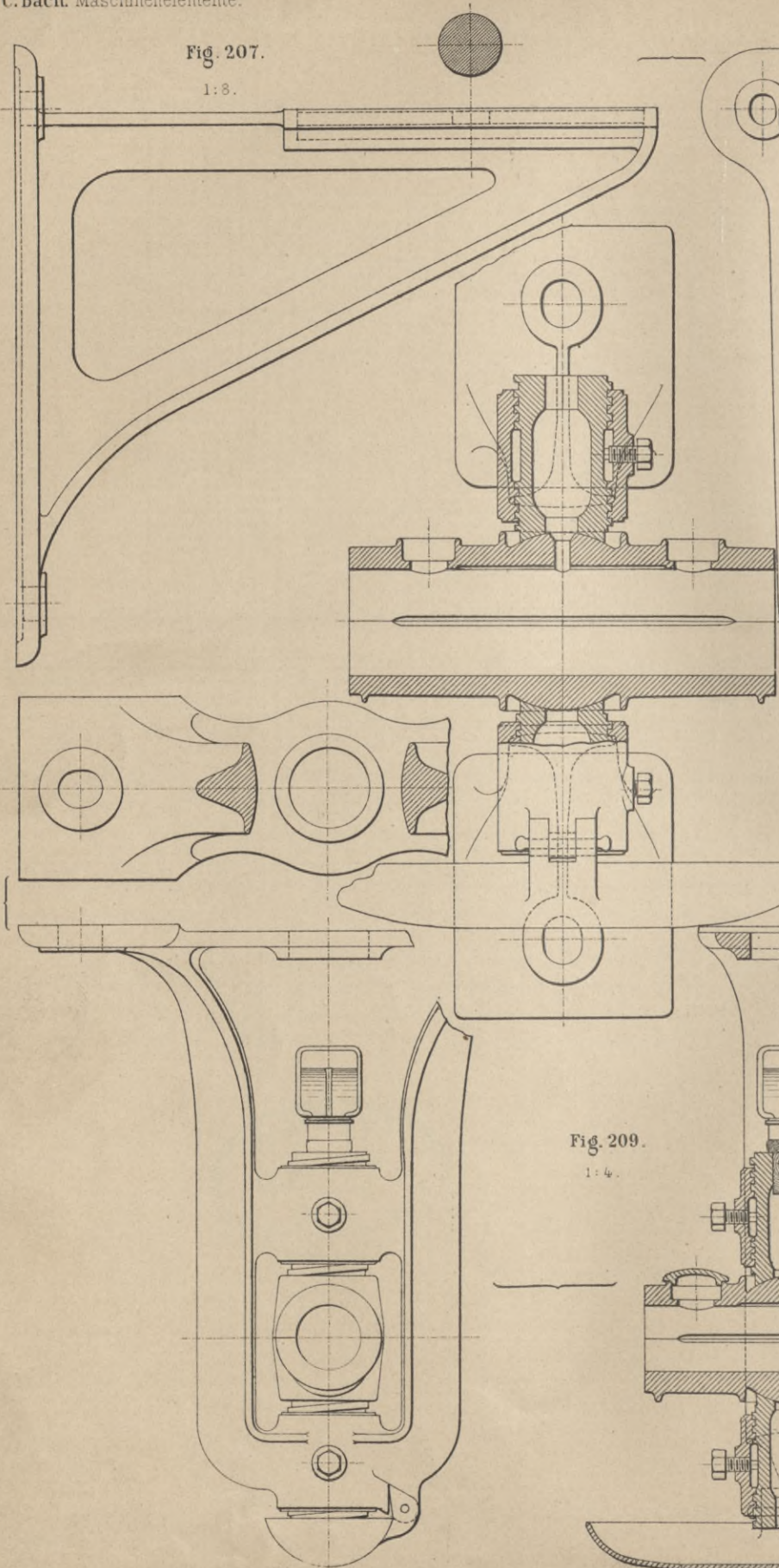


Fig. 208.

1:5.

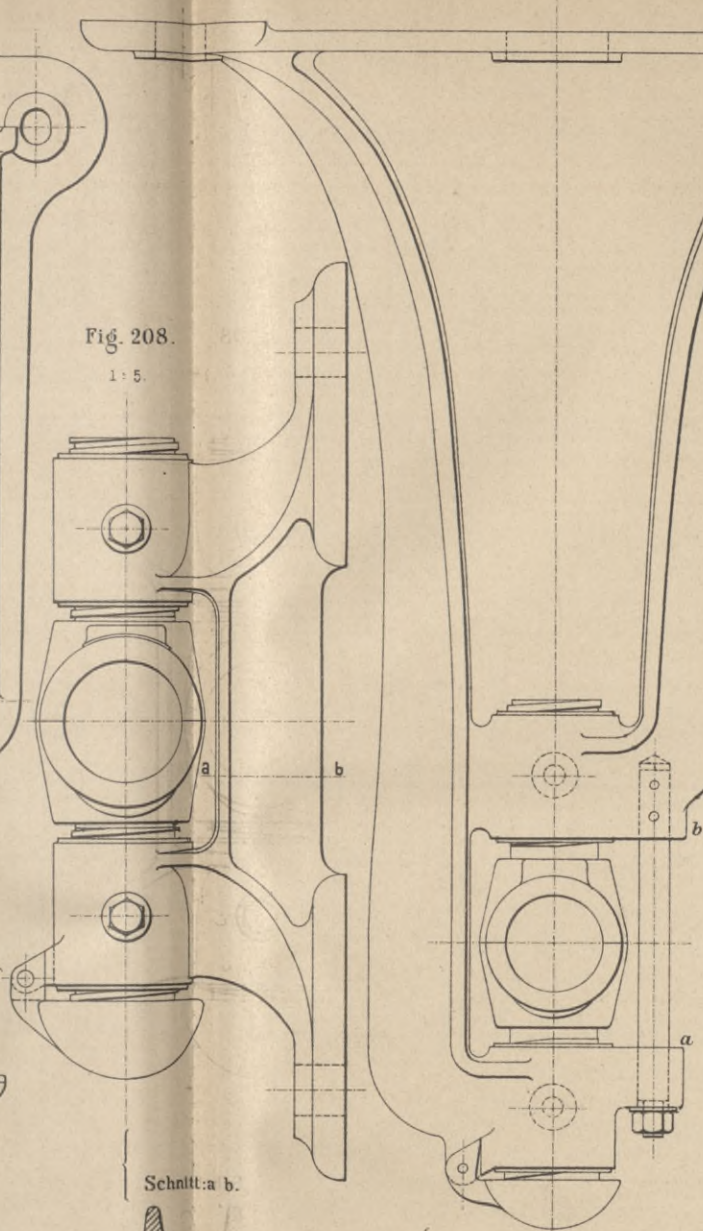


Fig. 210.

1:5.

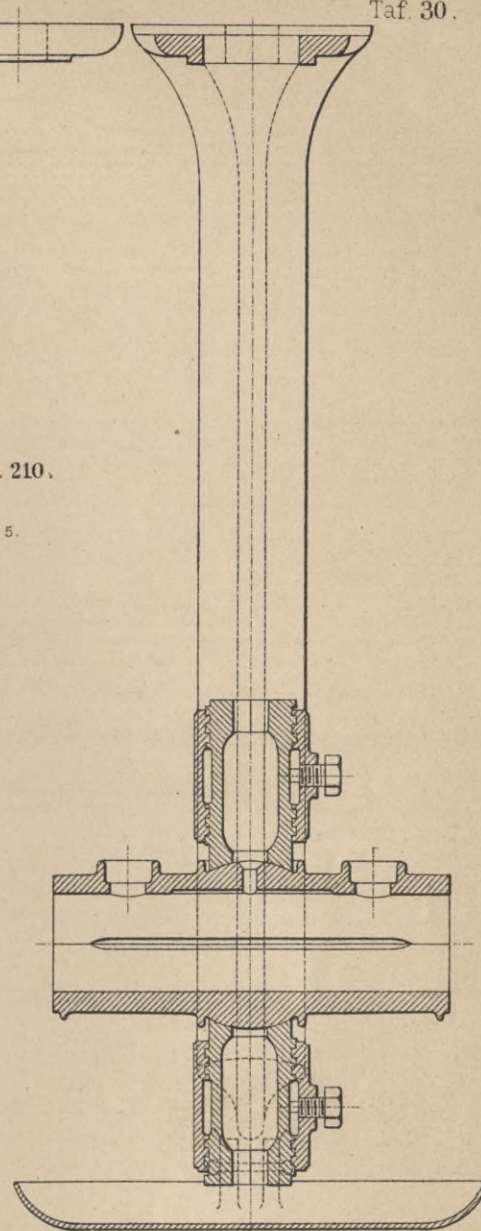
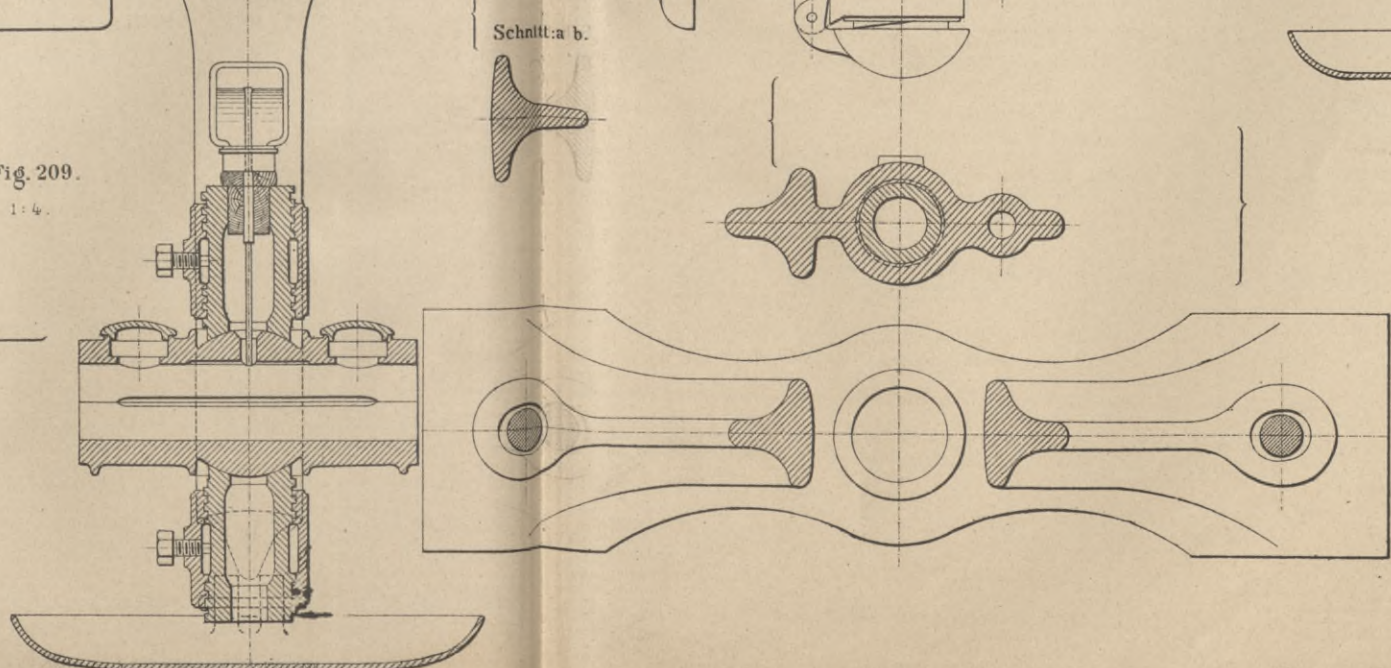


Fig. 209.

1:4.



Schnitt: a b.



Fig. 211.

1:5.

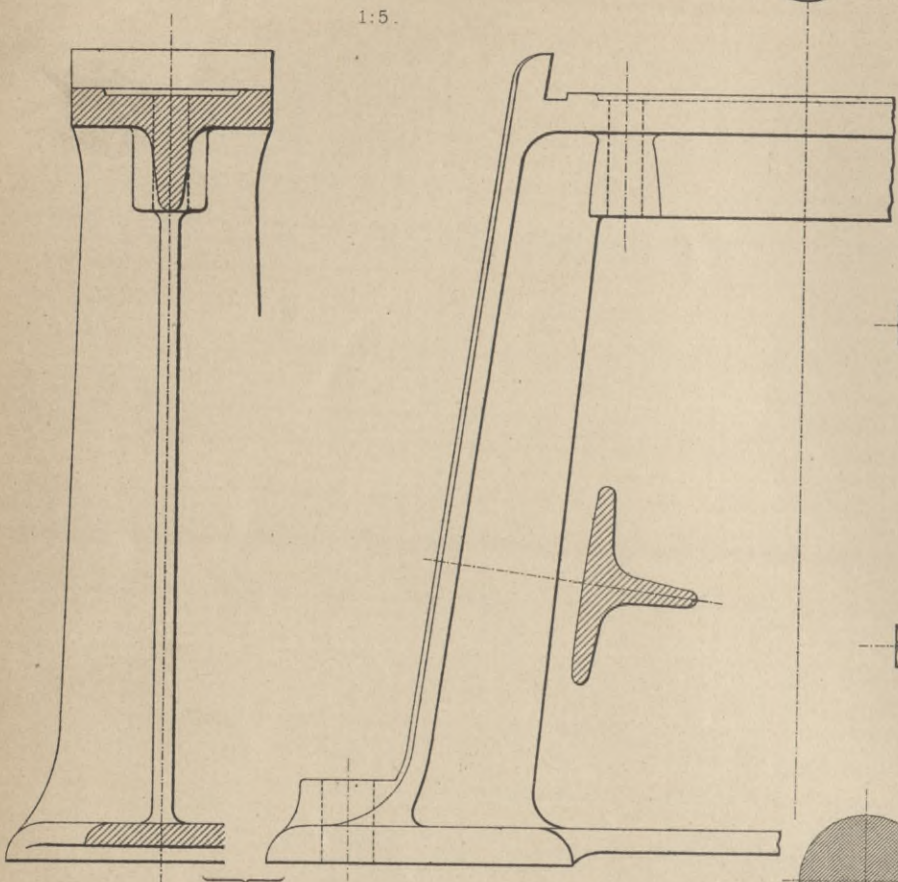


Fig. 219.

1:5.

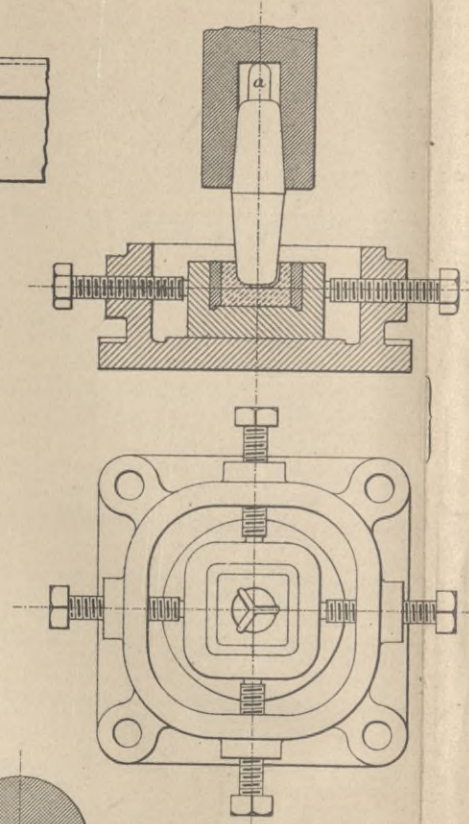


Fig. 220.

1:5.

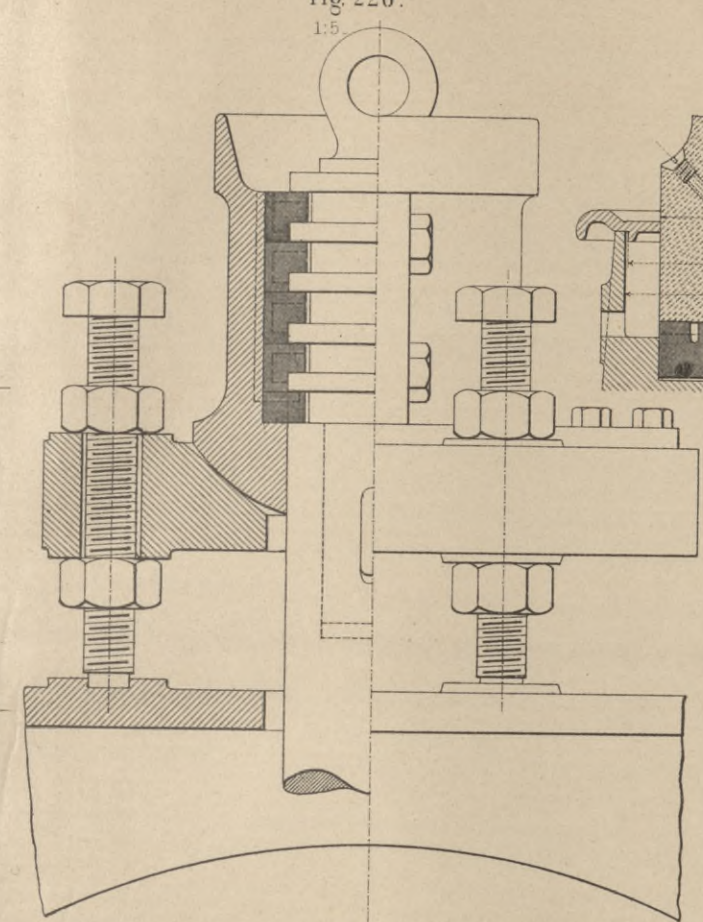


Fig. 216.

1:10.

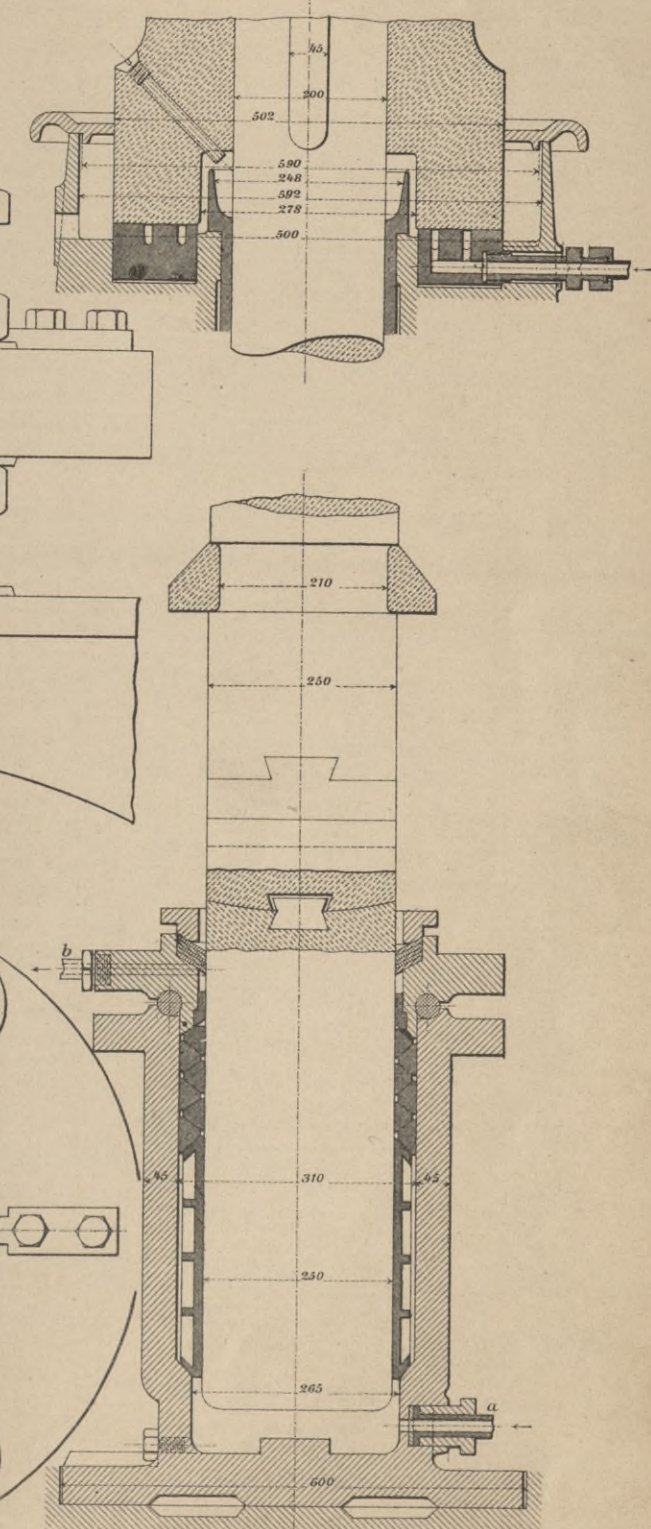
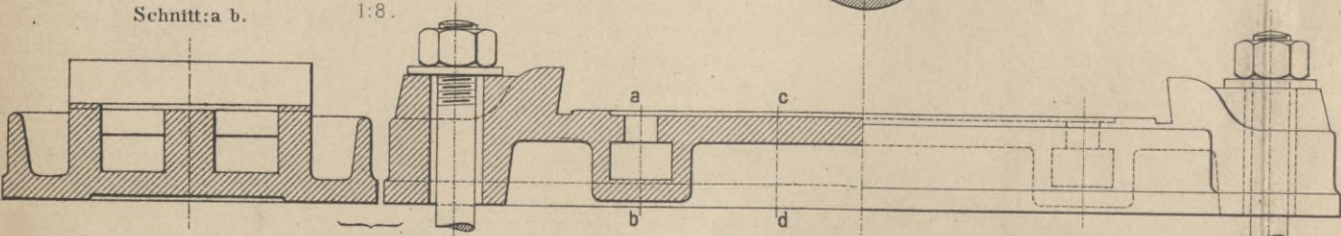


Fig. 212.

1:8.

Schnitt: a b.



Schnitt: c d.

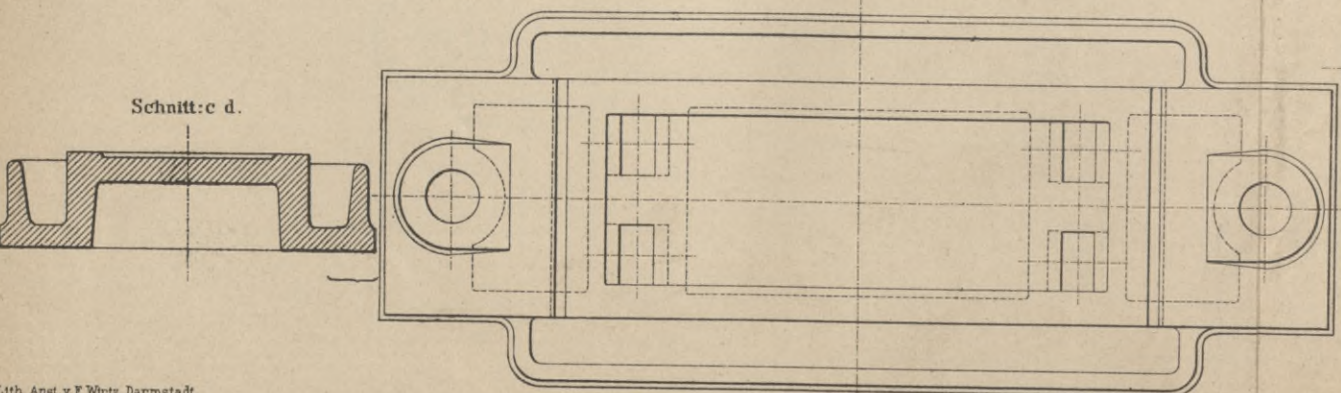


Fig. 215.
1:5.

Schnitt: d b.

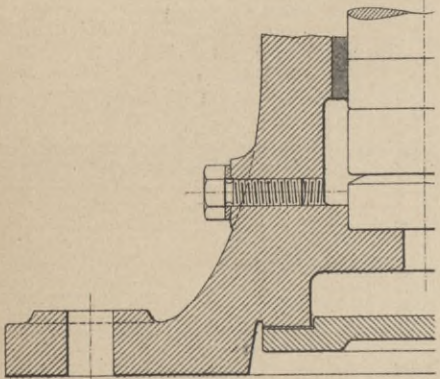


Fig. 214.
1:5.

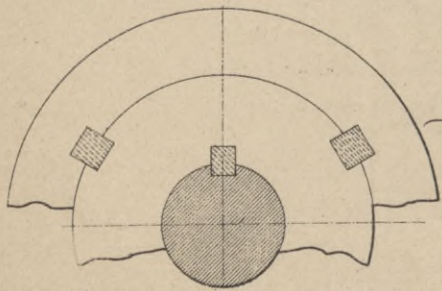
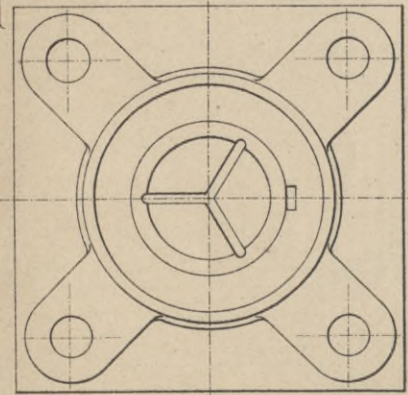
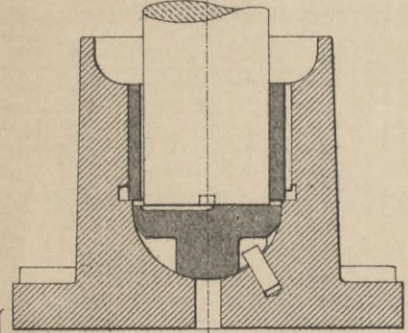
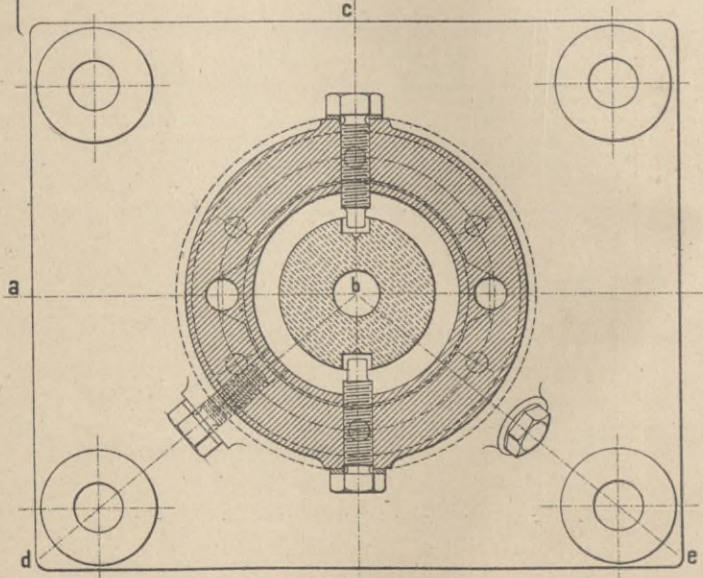
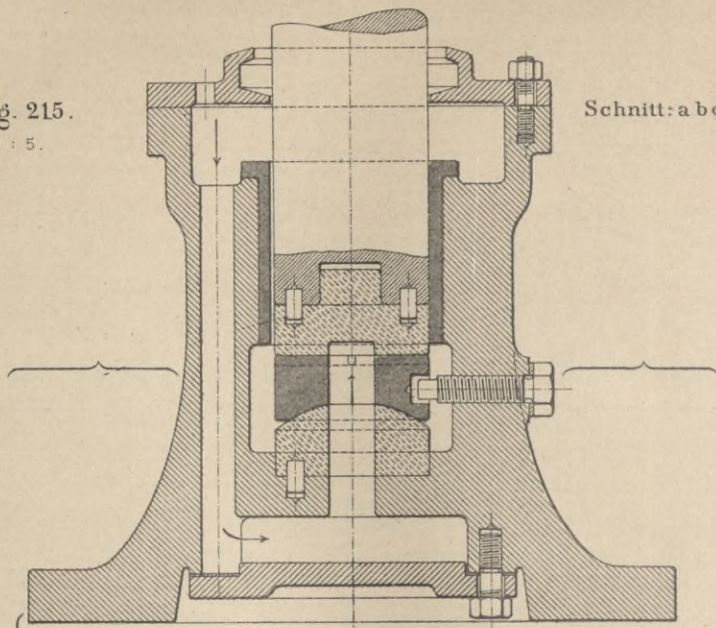


Fig. 223.
1:5.



Schnitt: a b c.



Schnitt: b e.

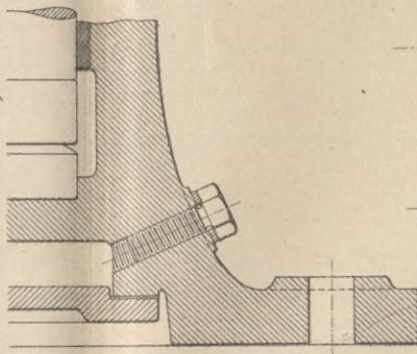


Fig. 224.
1:5.

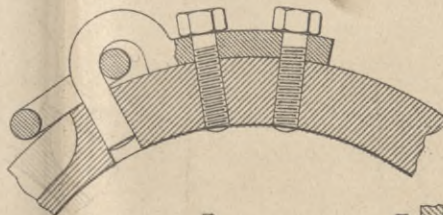


Fig. 250.

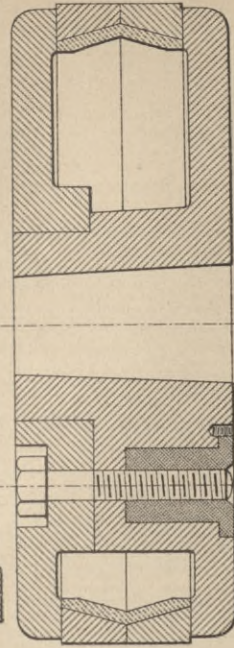


Fig. 251.

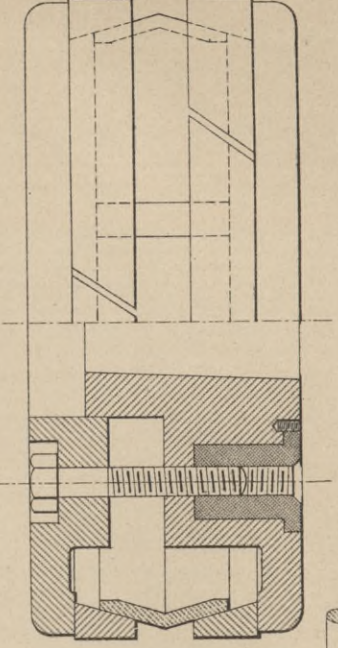


Fig. 225.
2:5.

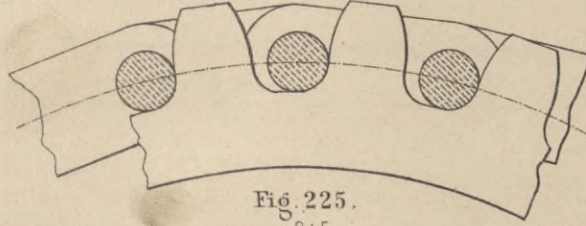


Fig. 222.
1:5.

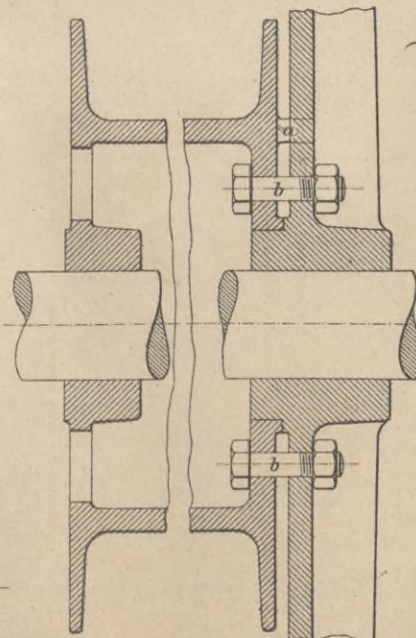
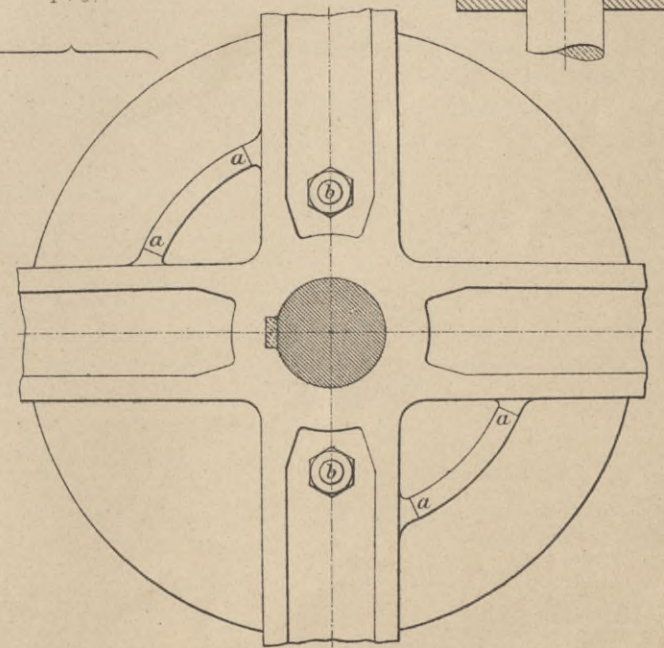
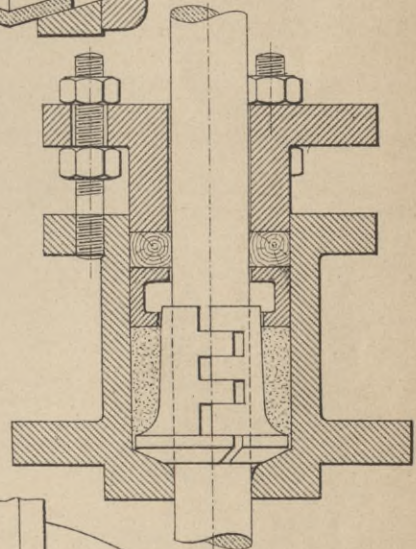


Fig. 274.



$3,5d + 3 \pm 6 \text{ mm}$



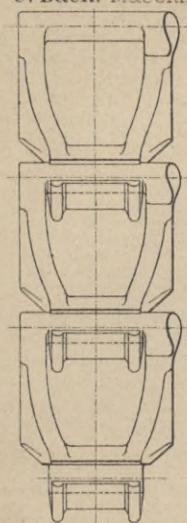


Fig. 226.

1:4.

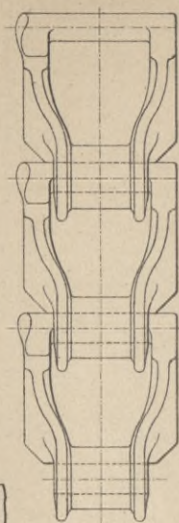


Fig. 227.

1:2.

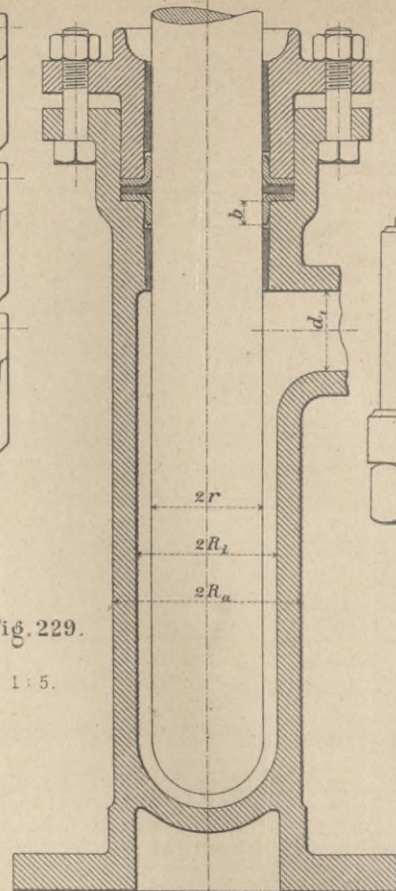


Fig. 229.

1:5.

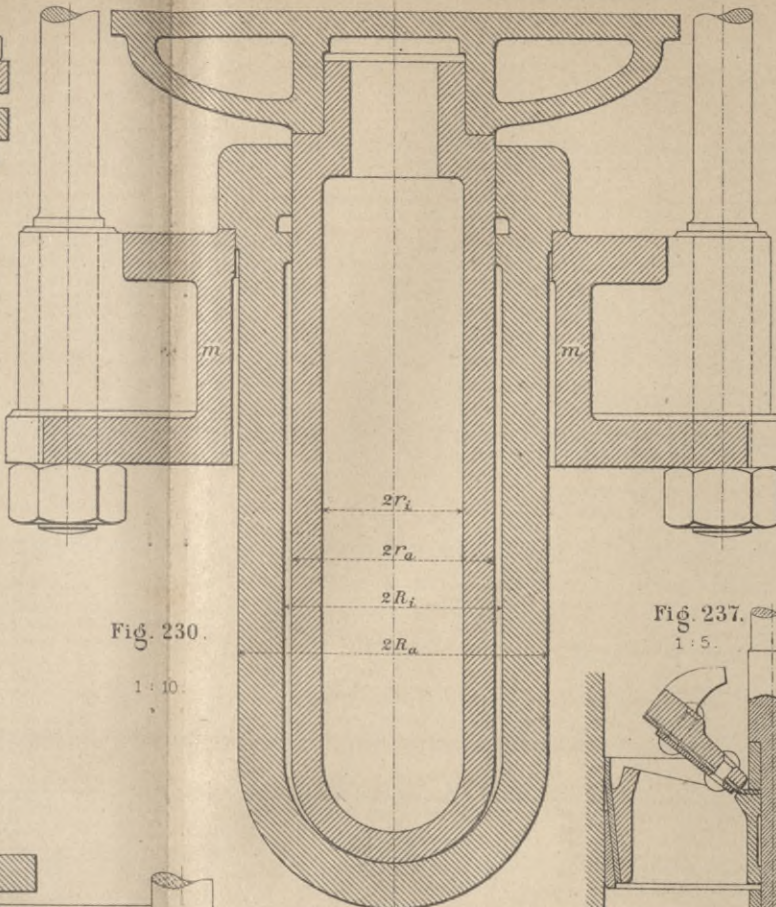


Fig. 230.

1:10.

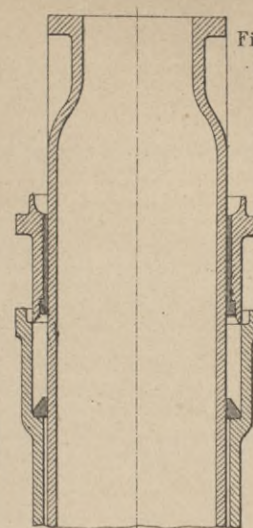


Fig. 235.

1:10.

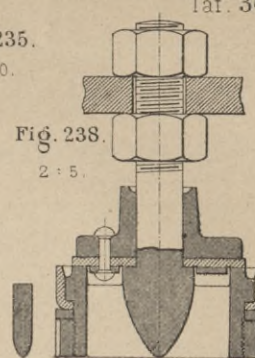


Fig. 238.

2:5.

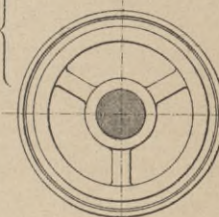


Fig. 228.

1:4.

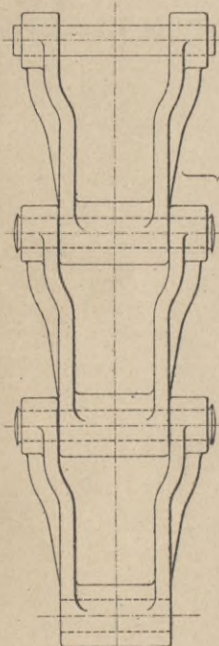


Fig. 231.

1:1.

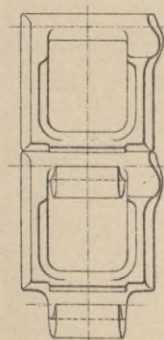
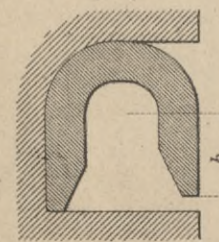


Fig. 233.

2:5.

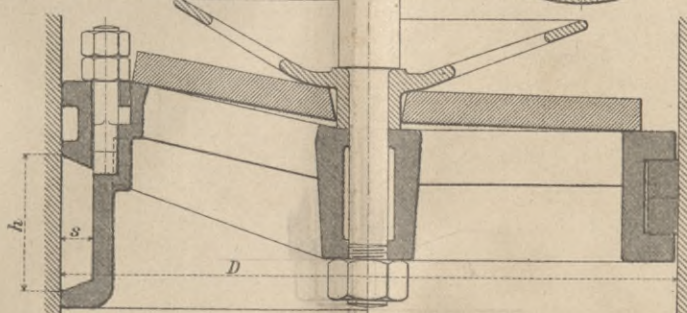
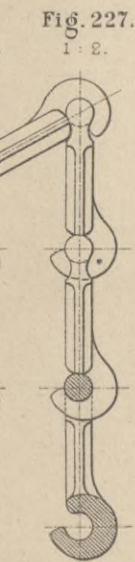


Fig. 236.

1:5.

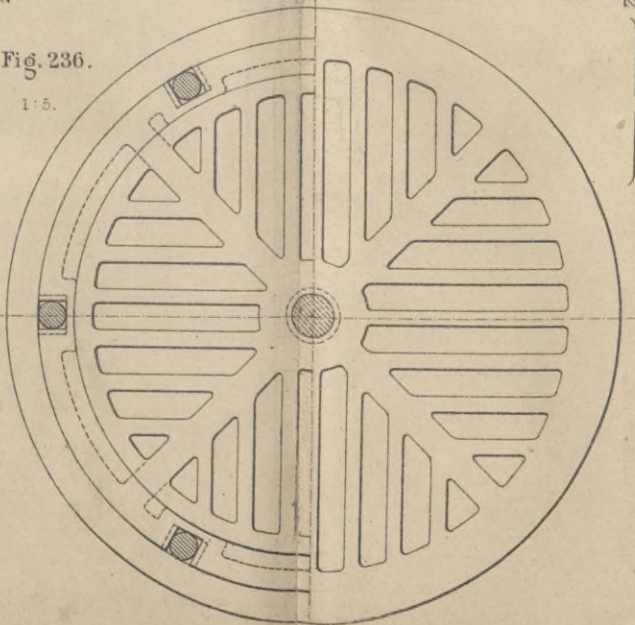


Fig. 237.

1:5.

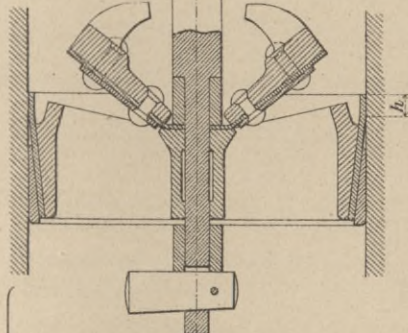


Fig. 239.

1:5.

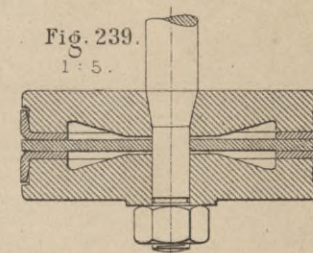


Fig. 234.

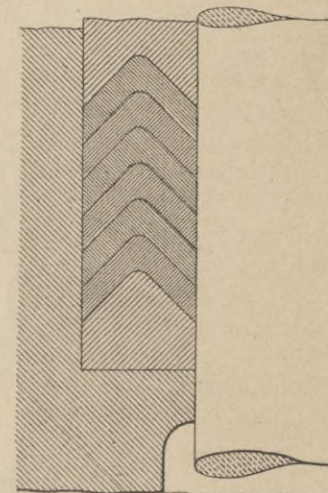
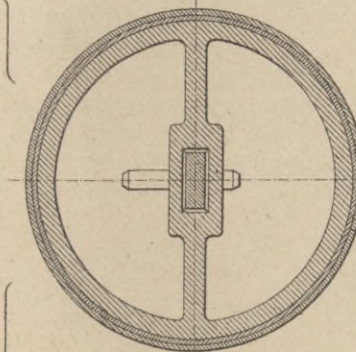
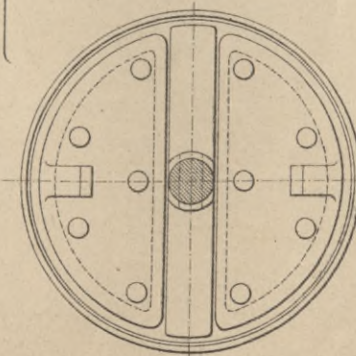


Fig. 232.

2:5.



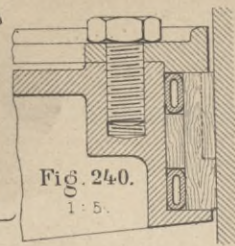
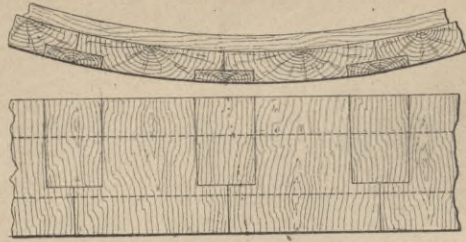


Fig. 240.
1:5.

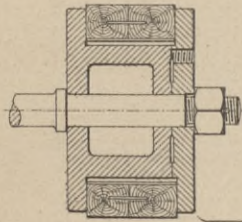


Fig. 241.
1:10.

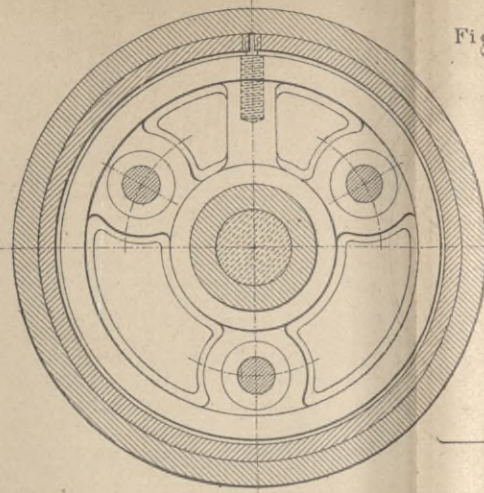


Fig. 246.
1:4.

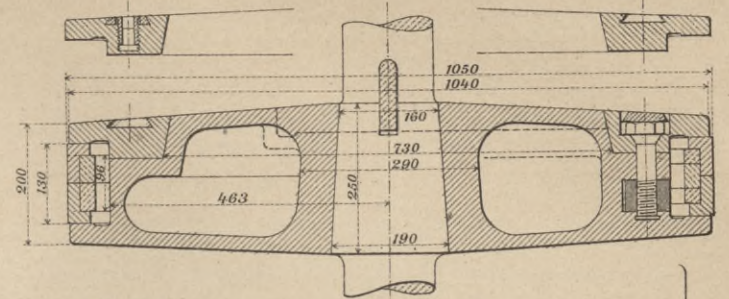
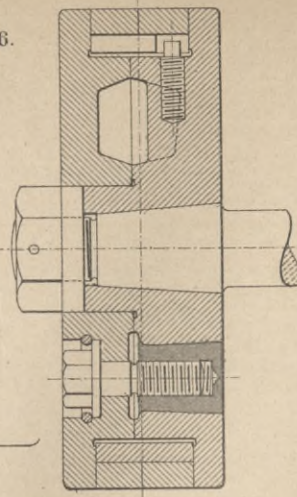


Fig. 248.

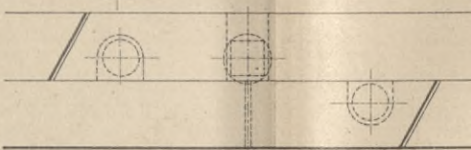


Fig. 242.
1:5.

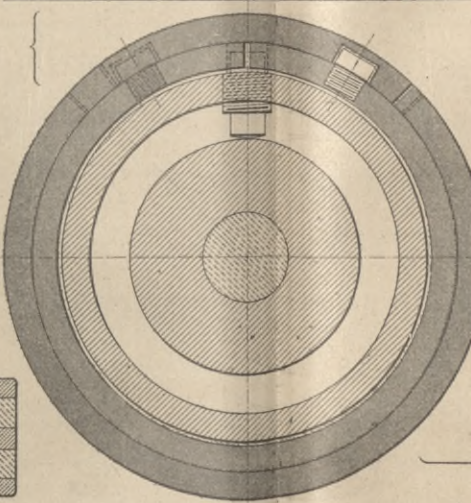


Fig. 247.
2:5.

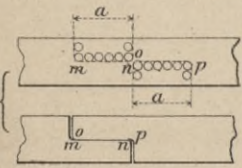
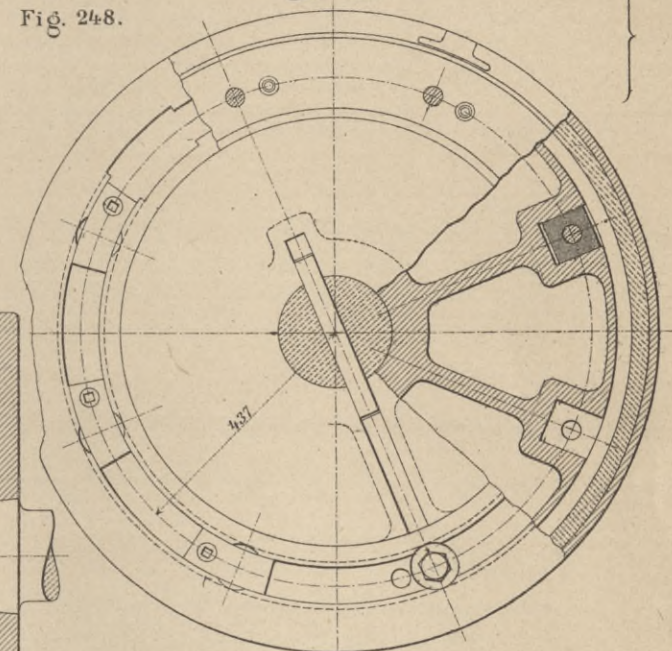
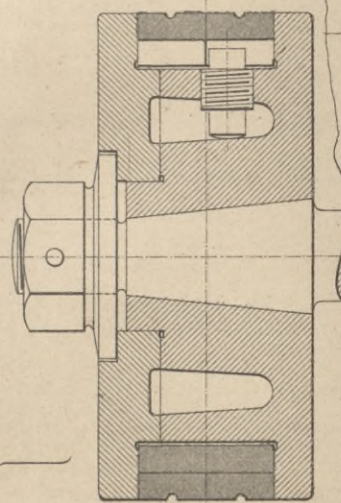


Fig. 243.
1:5.

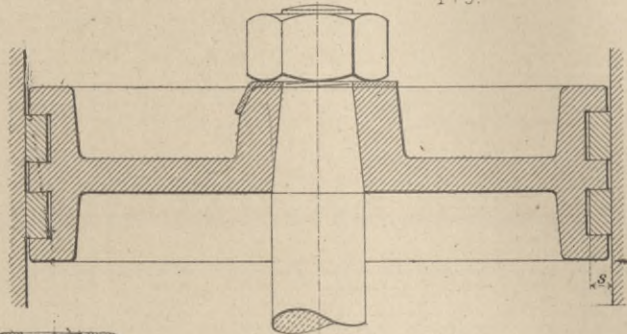


Fig. 244.
1:2.

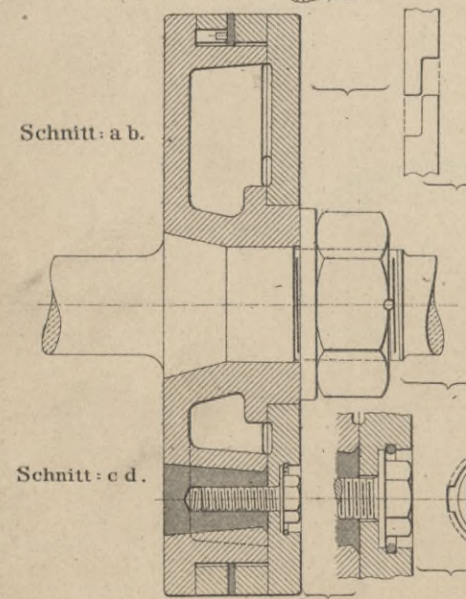
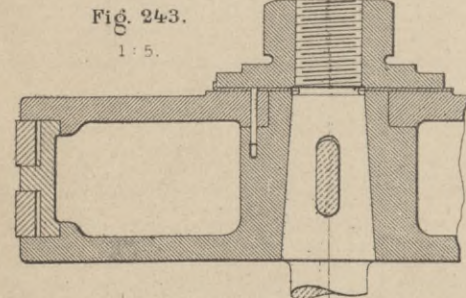


Fig. 245.
1:5.

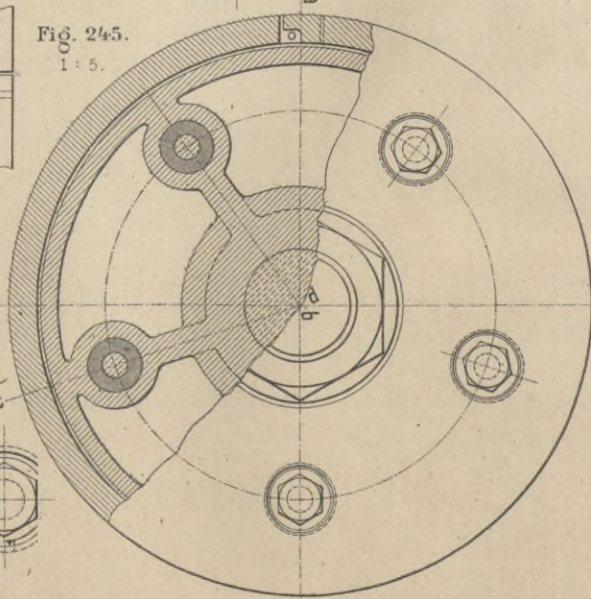


Fig. 256.
2:5.

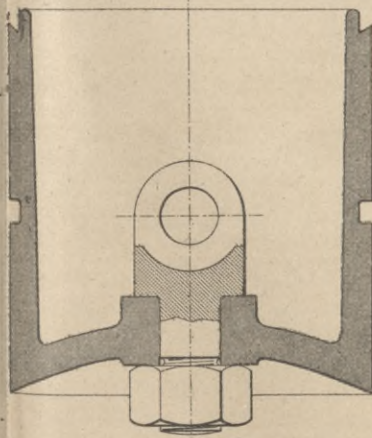


Fig. 257.
2:5.

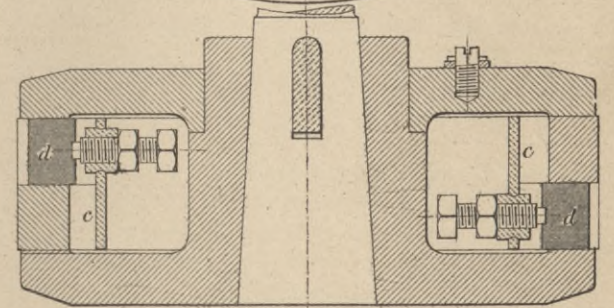
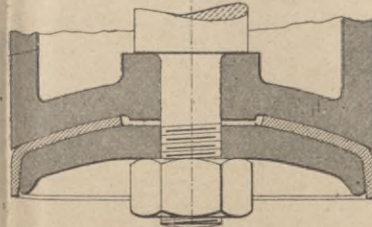
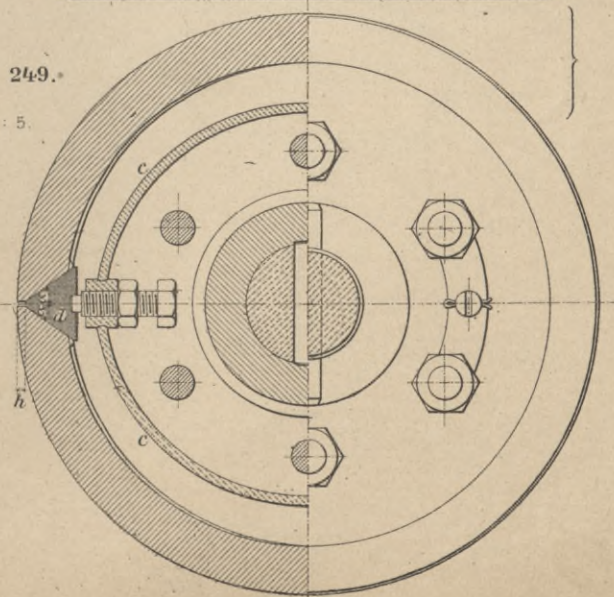


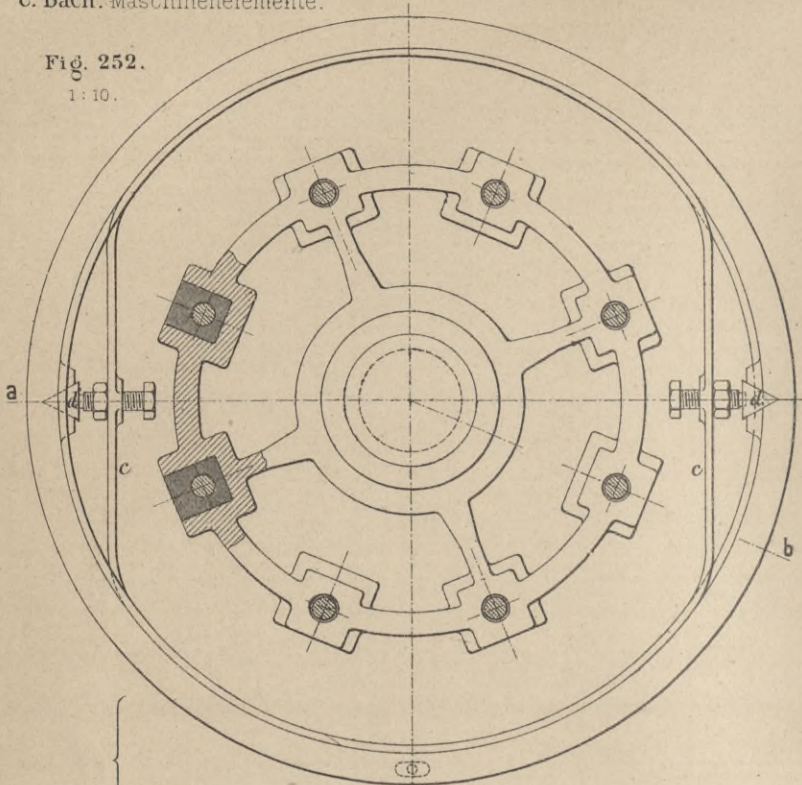
Fig. 249.
1:5.



Schnitt: a b.

Schnitt: c d.

Fig. 252.
1:10.



Schnitt: a b.

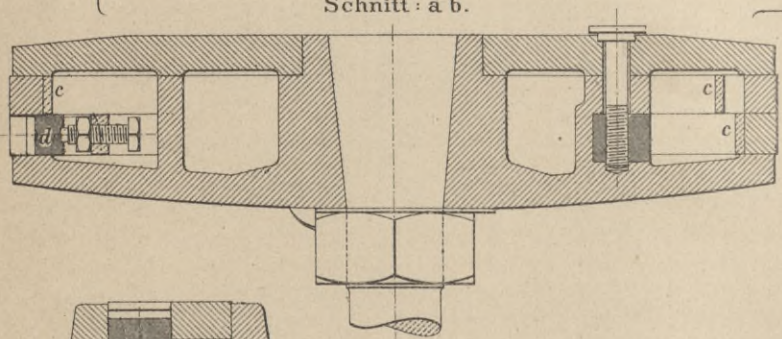
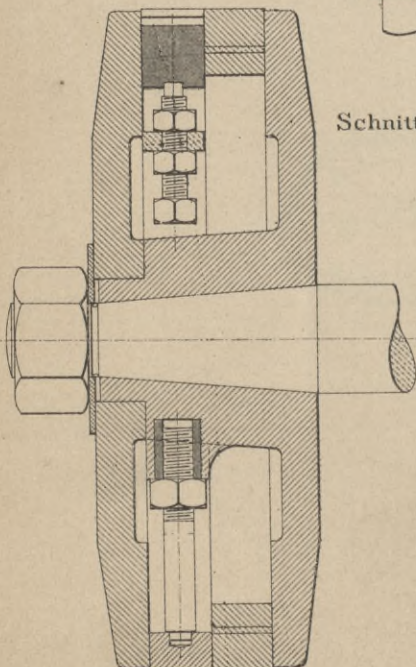


Fig. 253.
1:5.



Schnitt: c d.

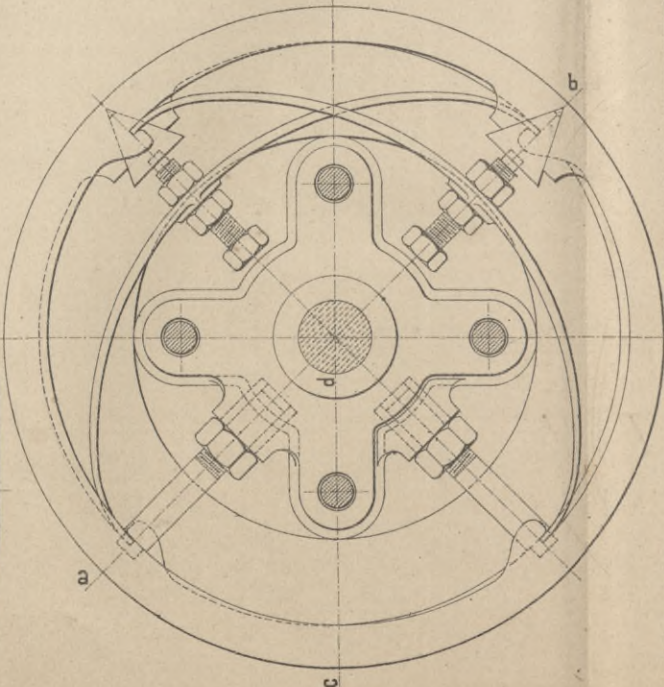
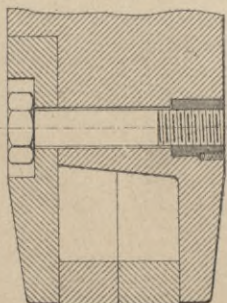
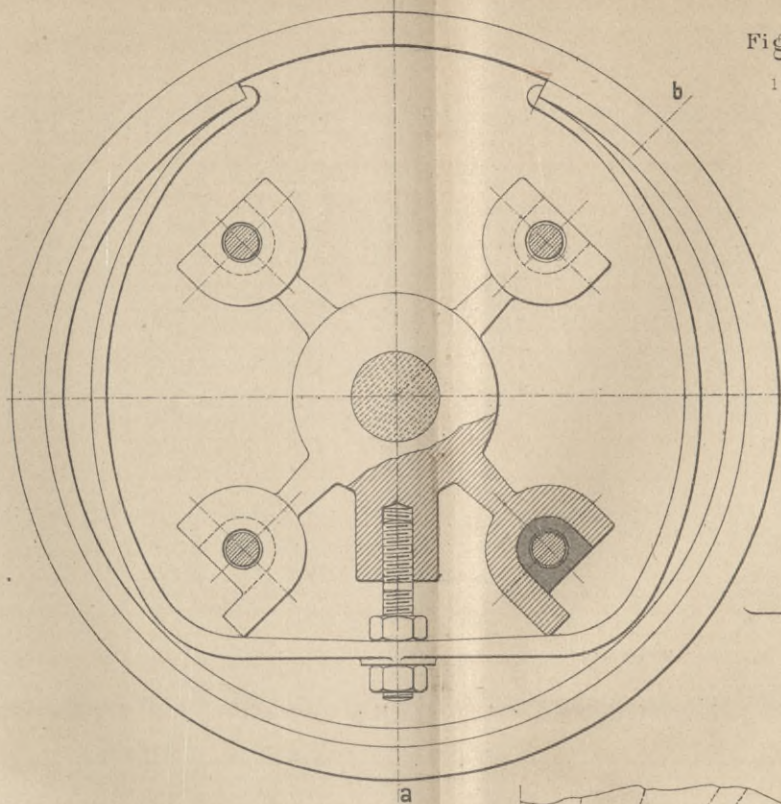


Fig. 254.
1:5.



a

b

Schnitt: a b.

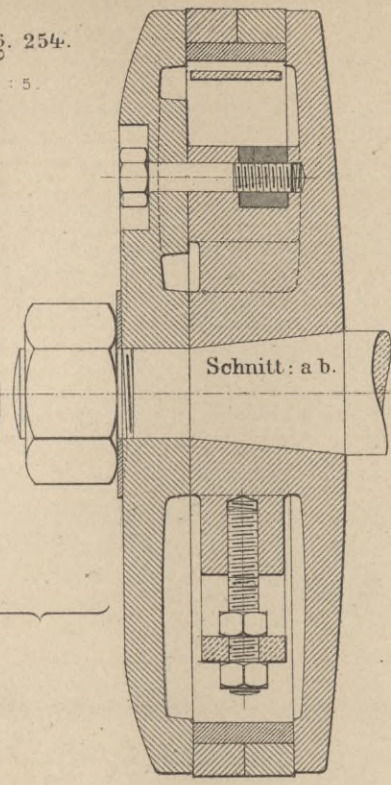
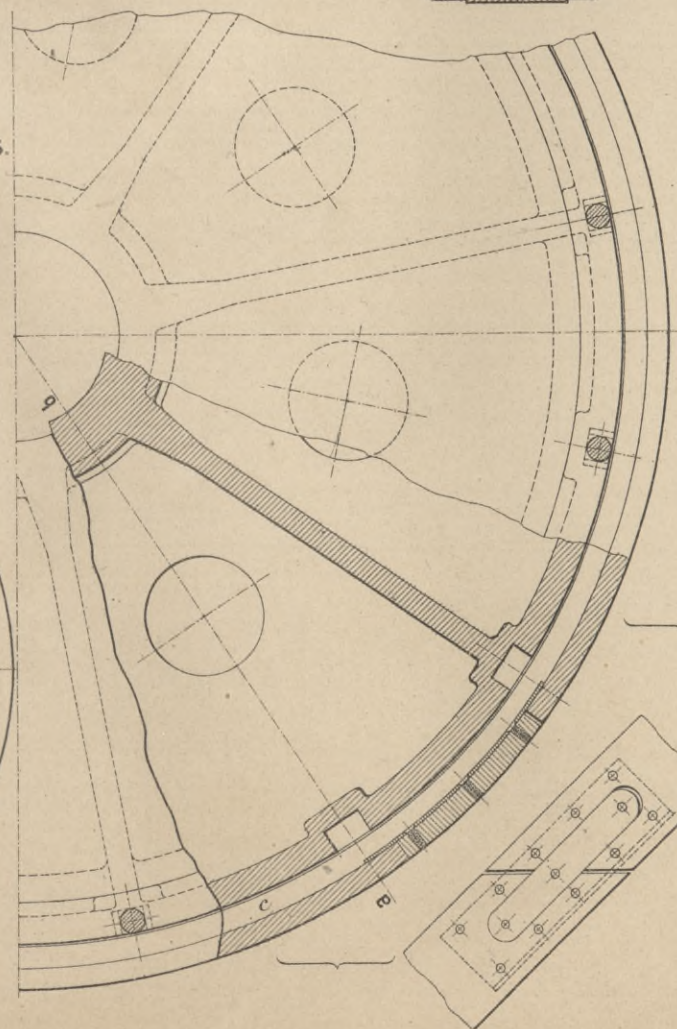


Fig. 255.
1:10.



b

a

Schnitt: a b.

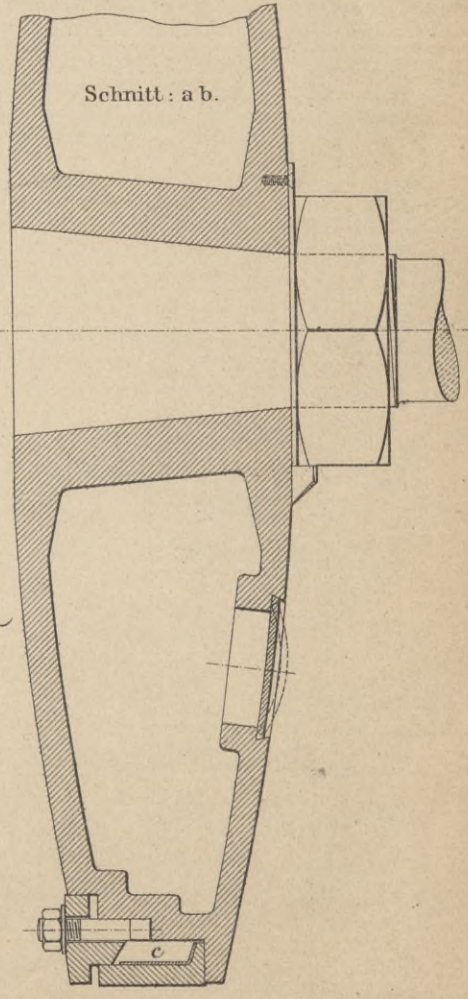


Fig. 259.
1:2.

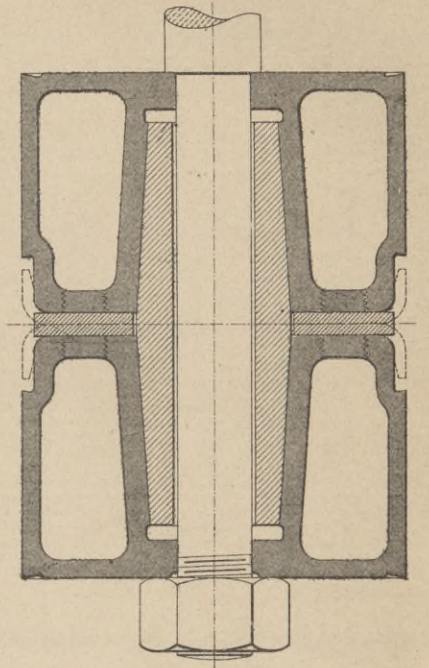


Fig. 264. 2/5.

Fig. 265. 1:5.

Fig. 260. 1:5.

Fig. 262. 1:5.

Fig. 266. 1:5.

Fig. 269. 2:5.

Fig. 270. 2:5.

Fig. 263. 1:5.

Fig. 267. 1:5.

Fig. 261. 1:5.

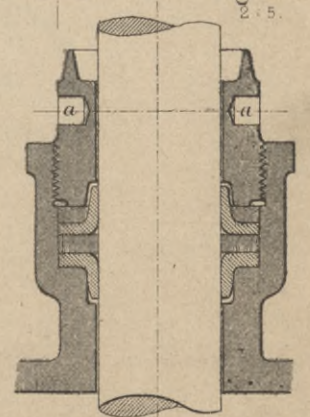
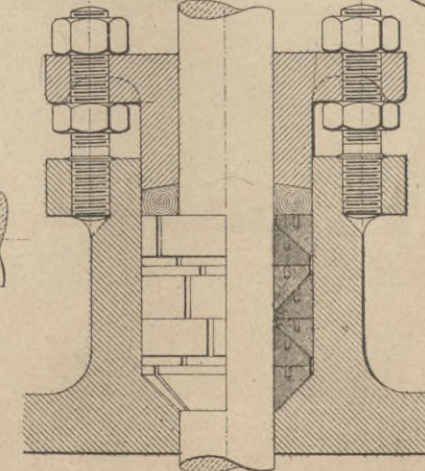
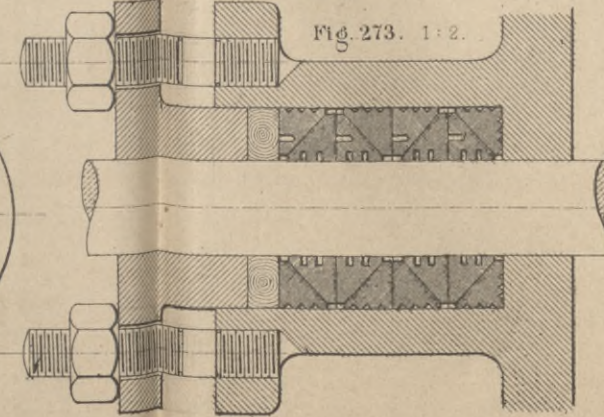
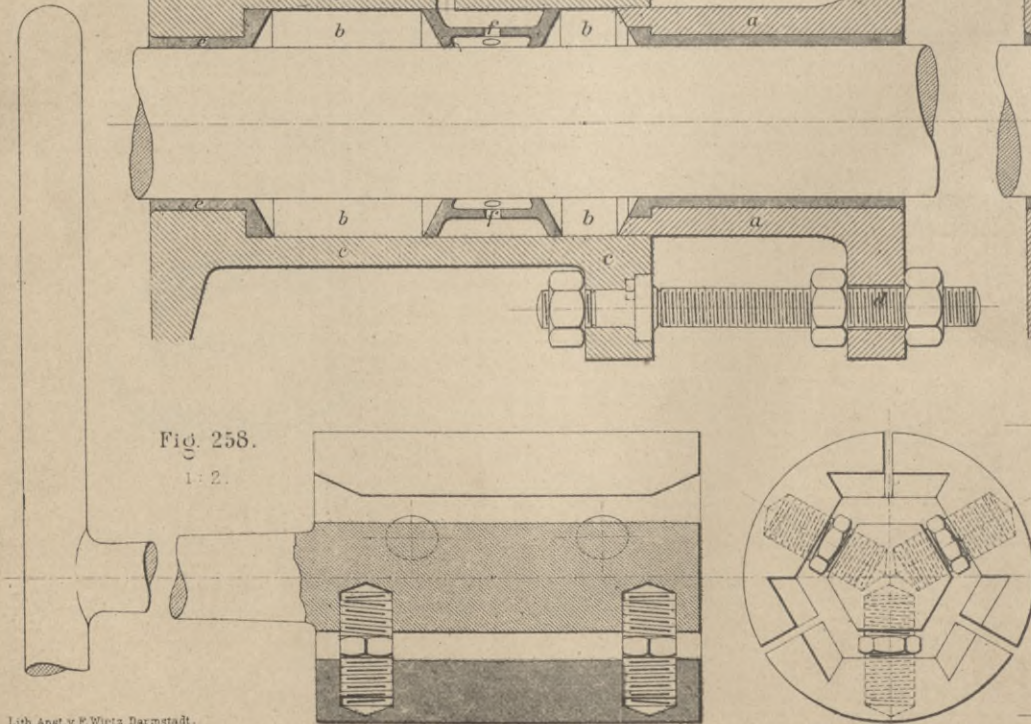
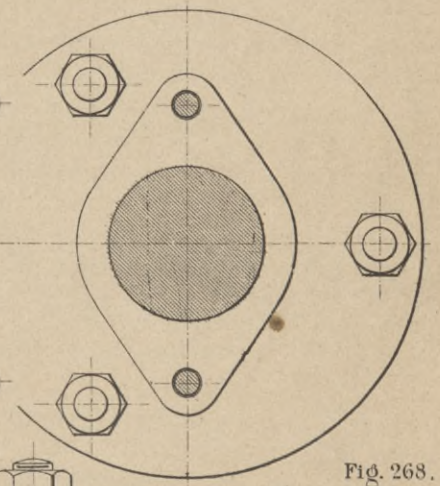
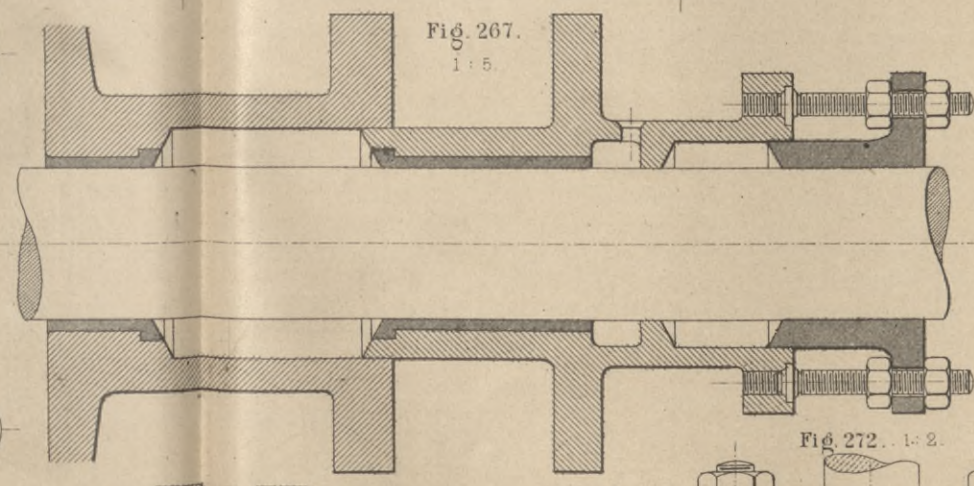
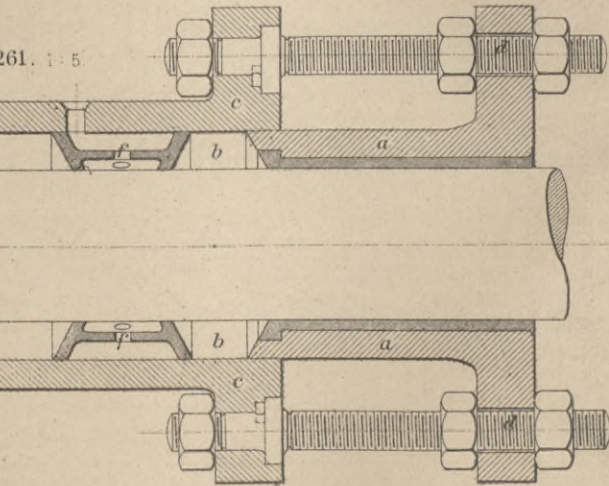
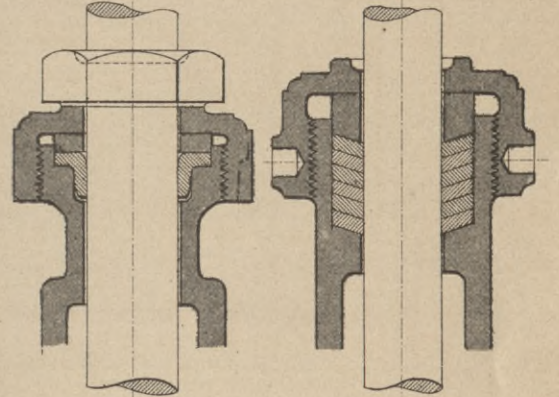
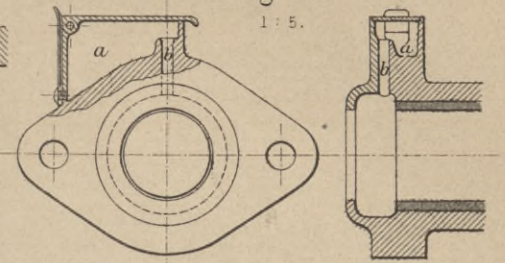
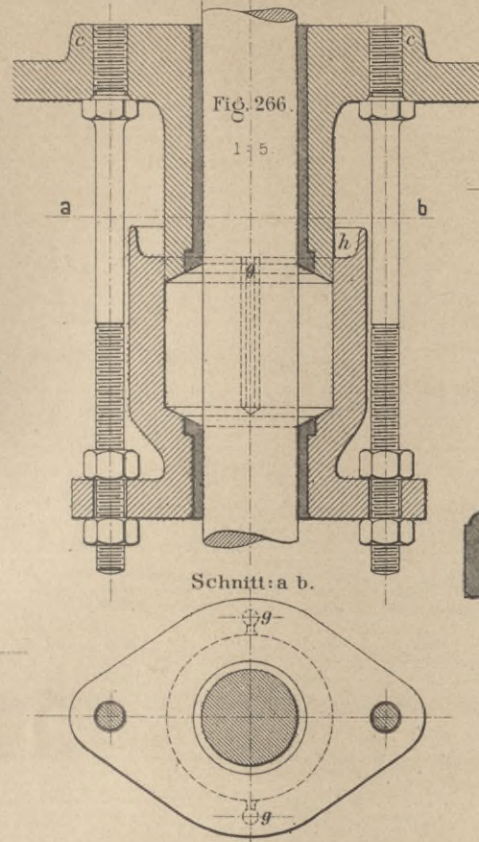
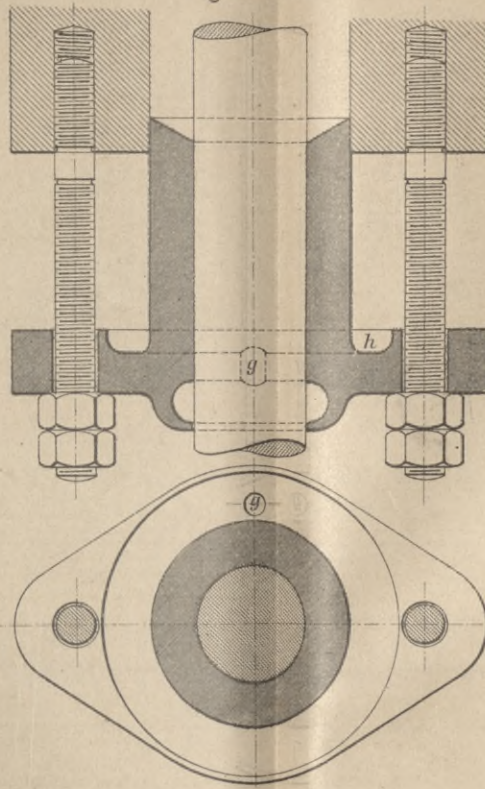
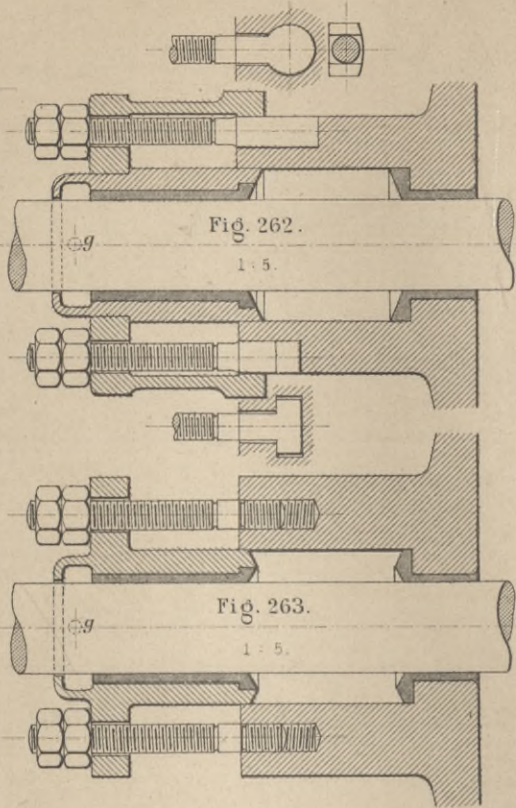
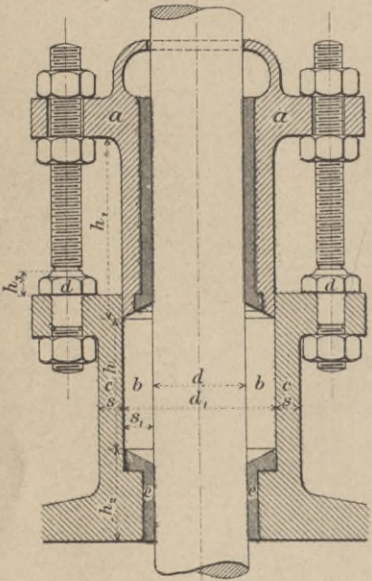
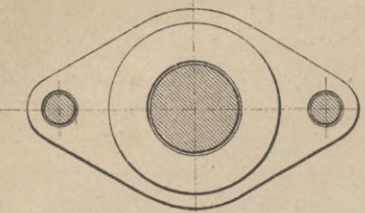
Fig. 273. 1:2.

Fig. 272. 1:2.

Fig. 268. 2:5.

Fig. 258. 1:2.

Schnitt: a b.



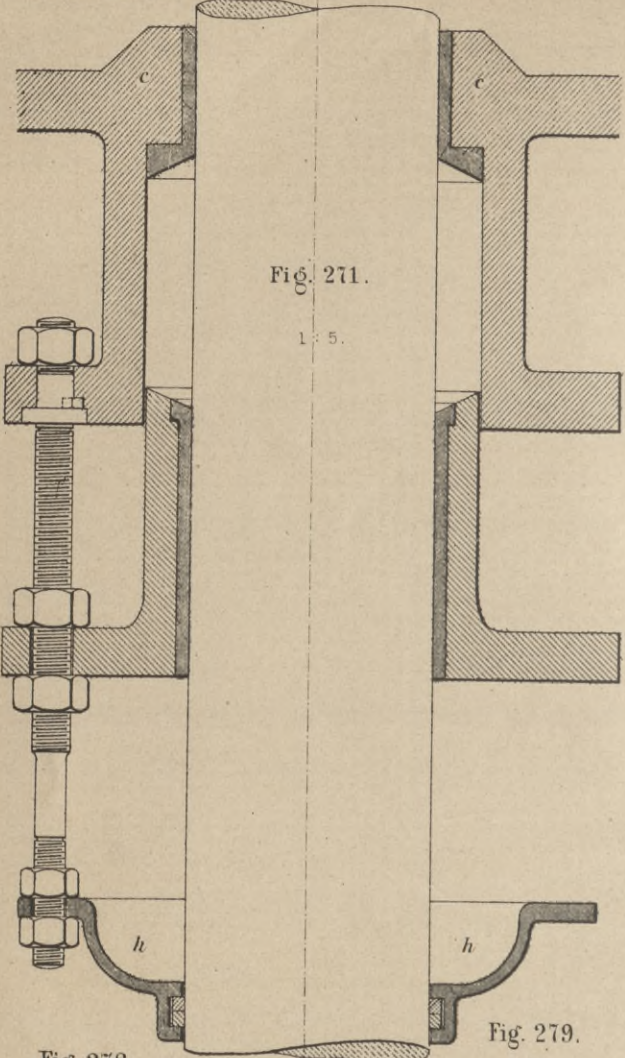


Fig. 271.
1:5.

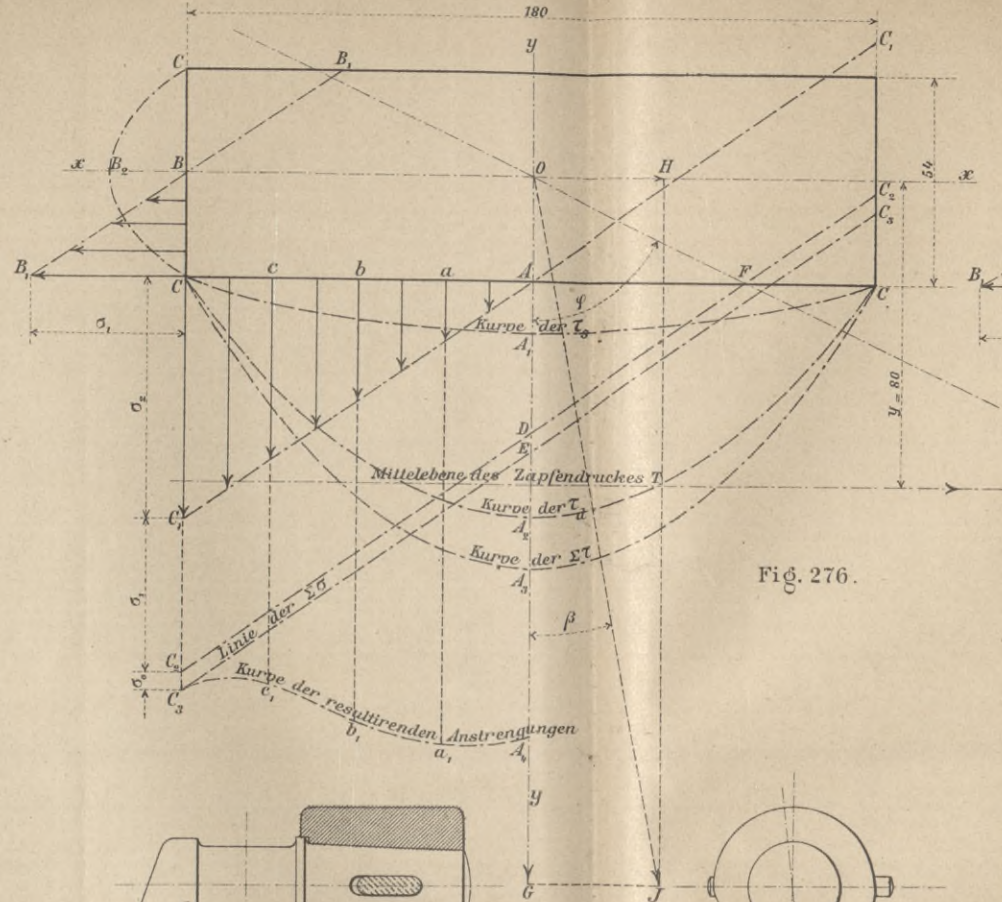


Fig. 276.

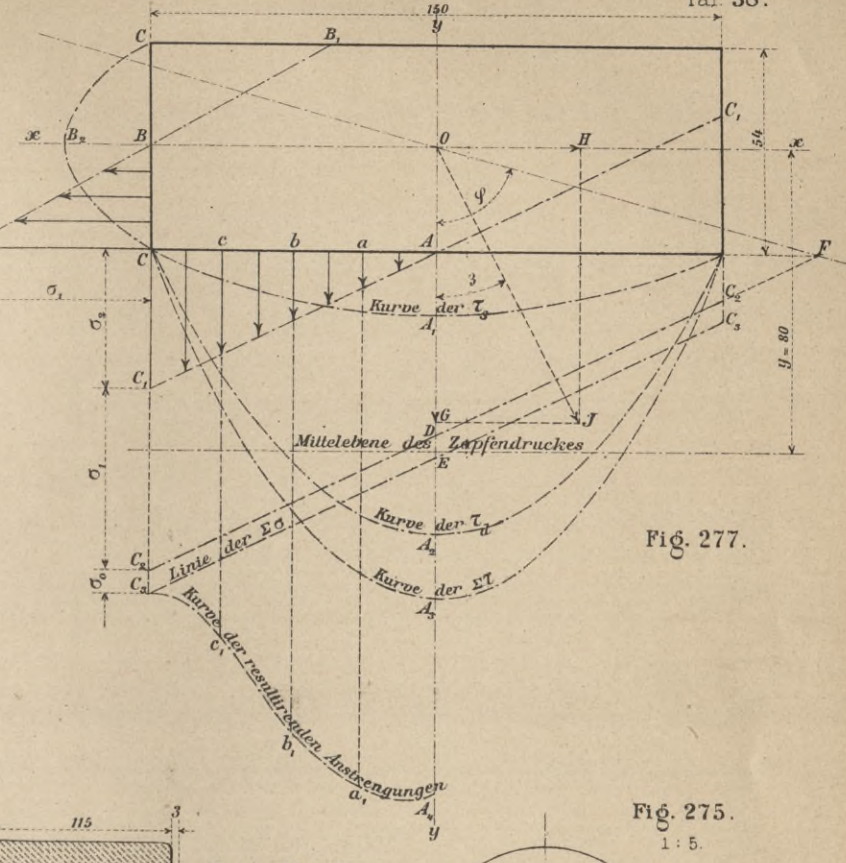


Fig. 277.

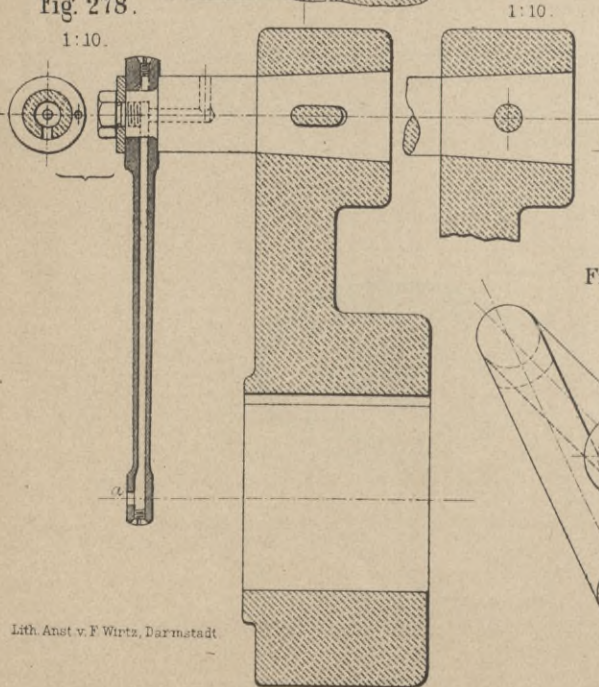


Fig. 278.
1:10.

Fig. 279.
1:10.

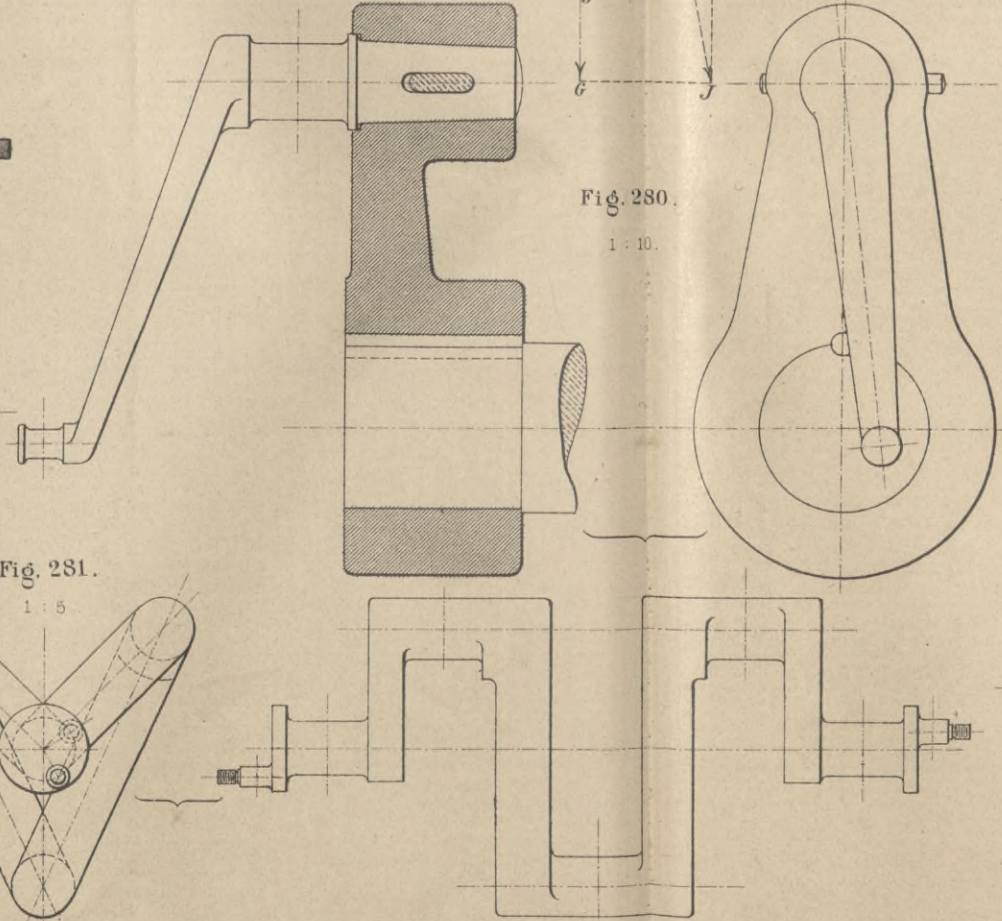


Fig. 280.
1:10.

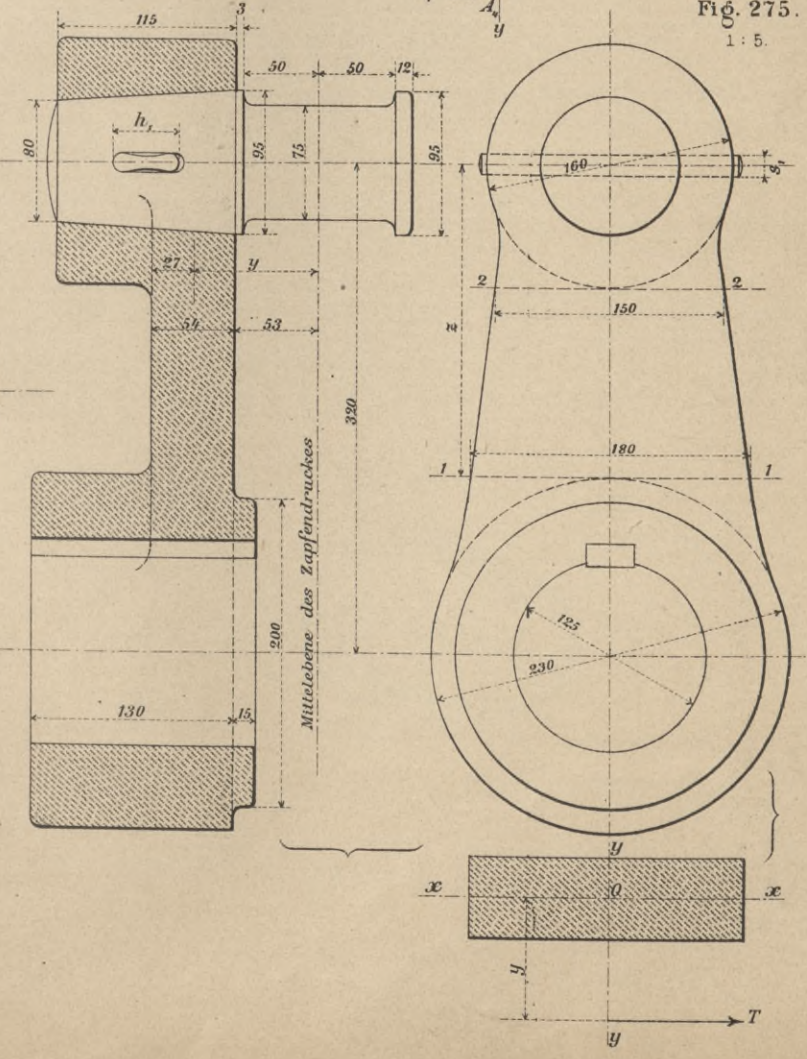


Fig. 275.
1:5.

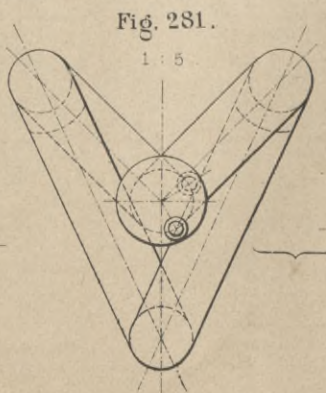


Fig. 281.
1:5.

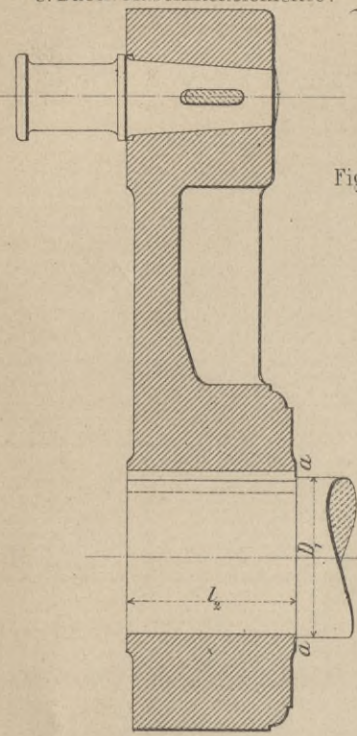


Fig. 282.
1:10

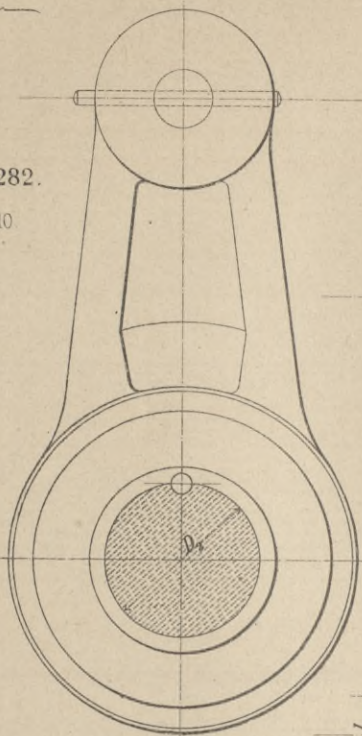


Fig. 283.
1:5.

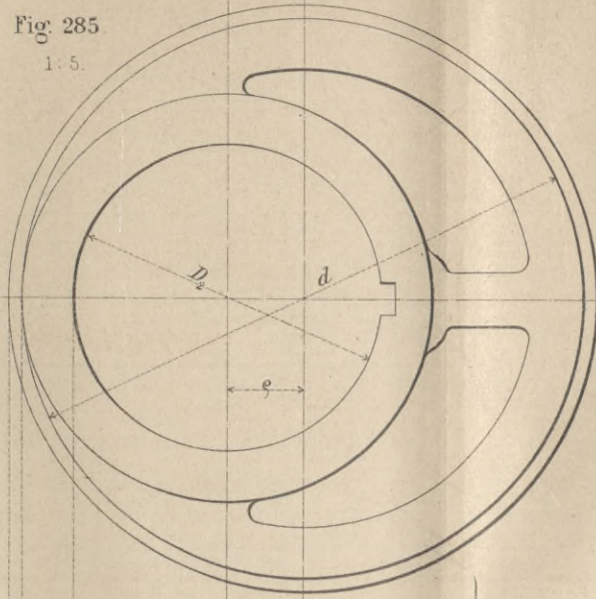


Fig. 285.
1:5.

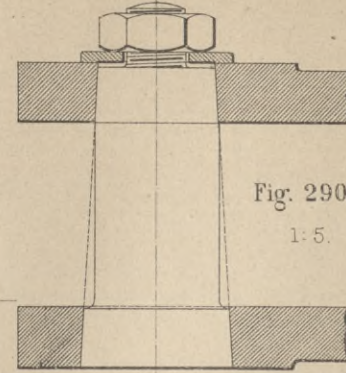


Fig. 290.
1:5.

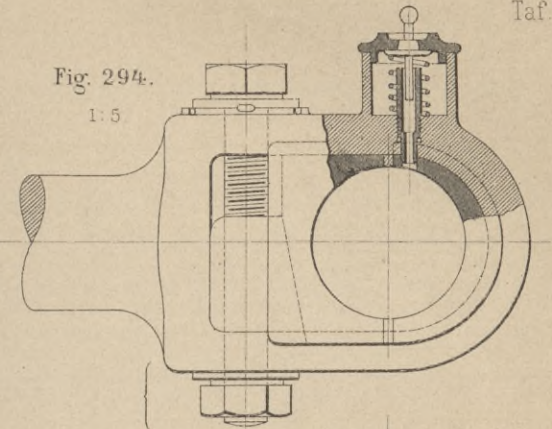


Fig. 294.
1:5

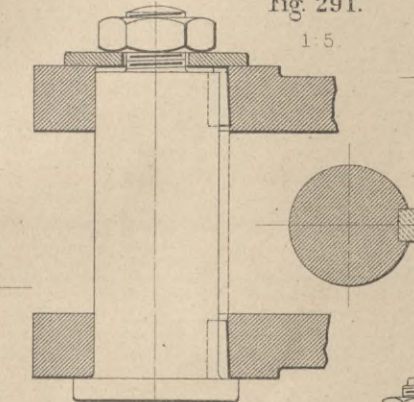


Fig. 291.
1:5

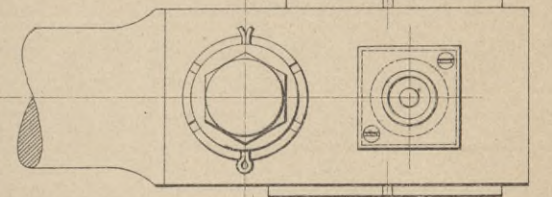


Fig. 288.
1:5.

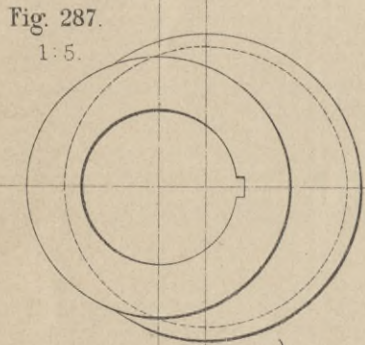


Fig. 287.
1:5.

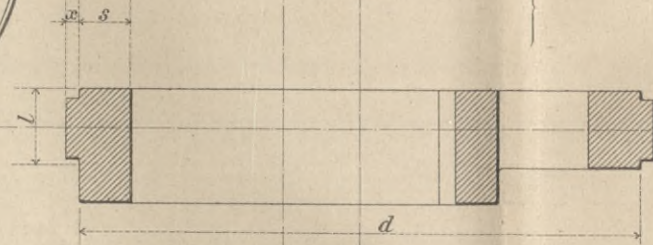


Fig. 284.
1:5.

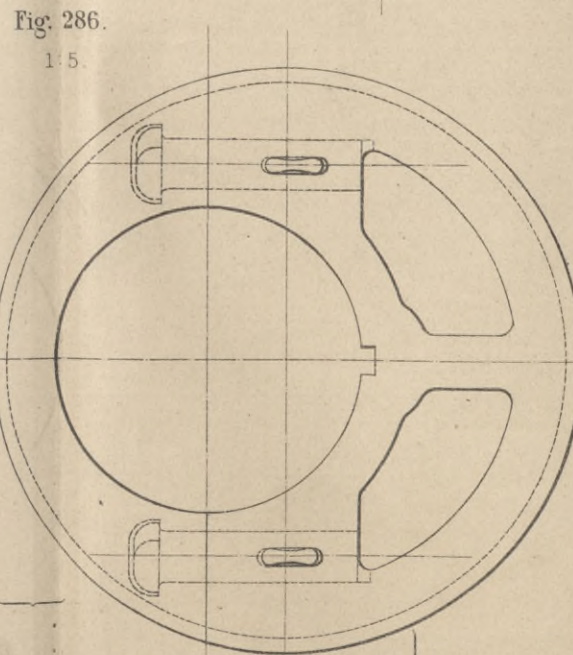
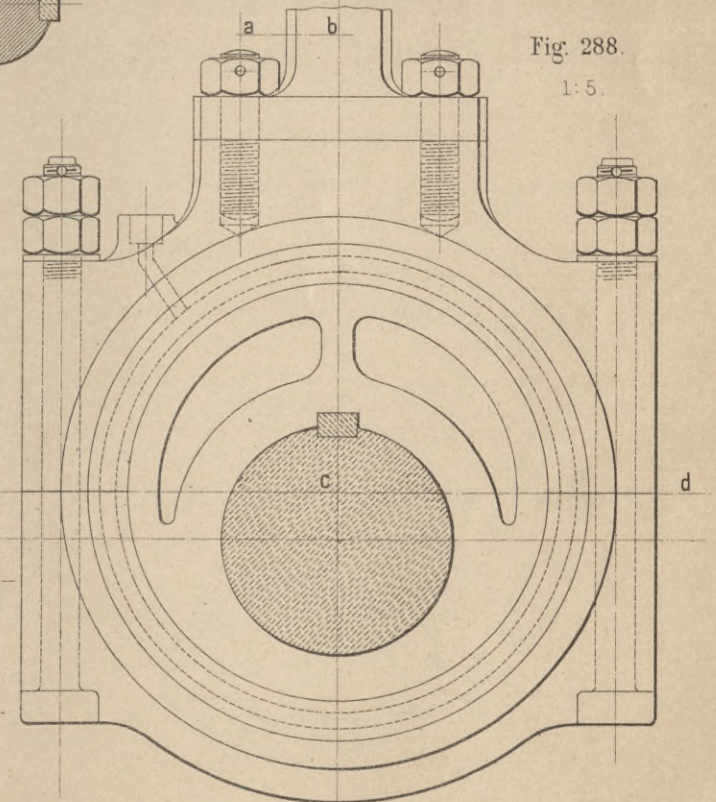
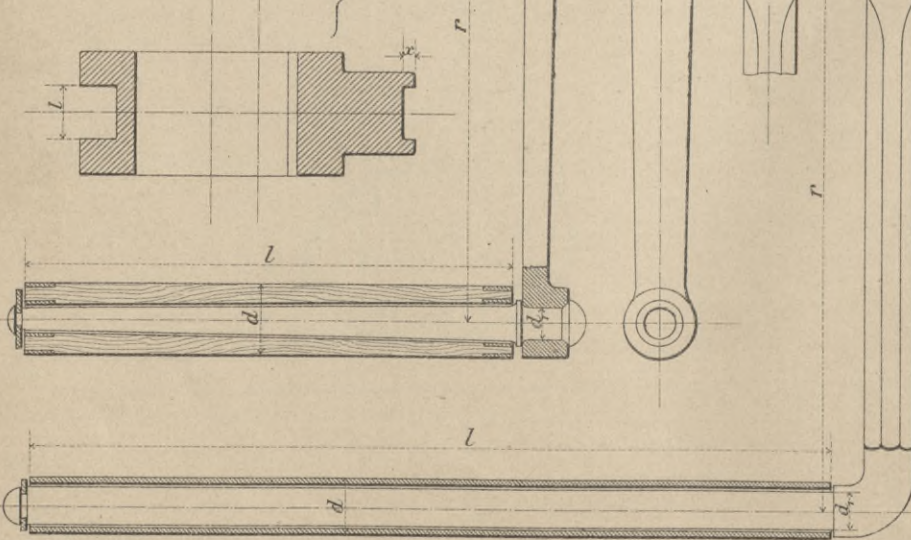
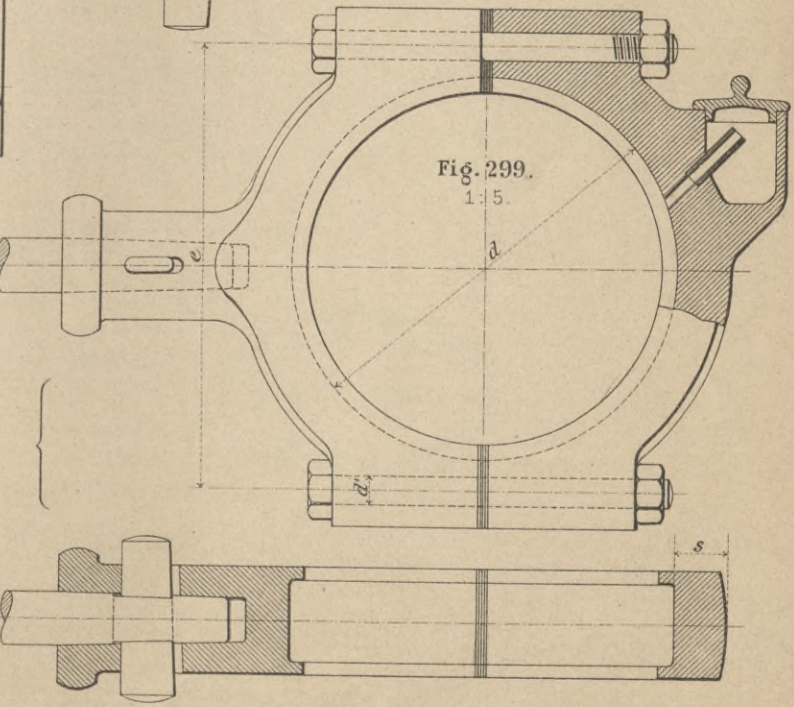
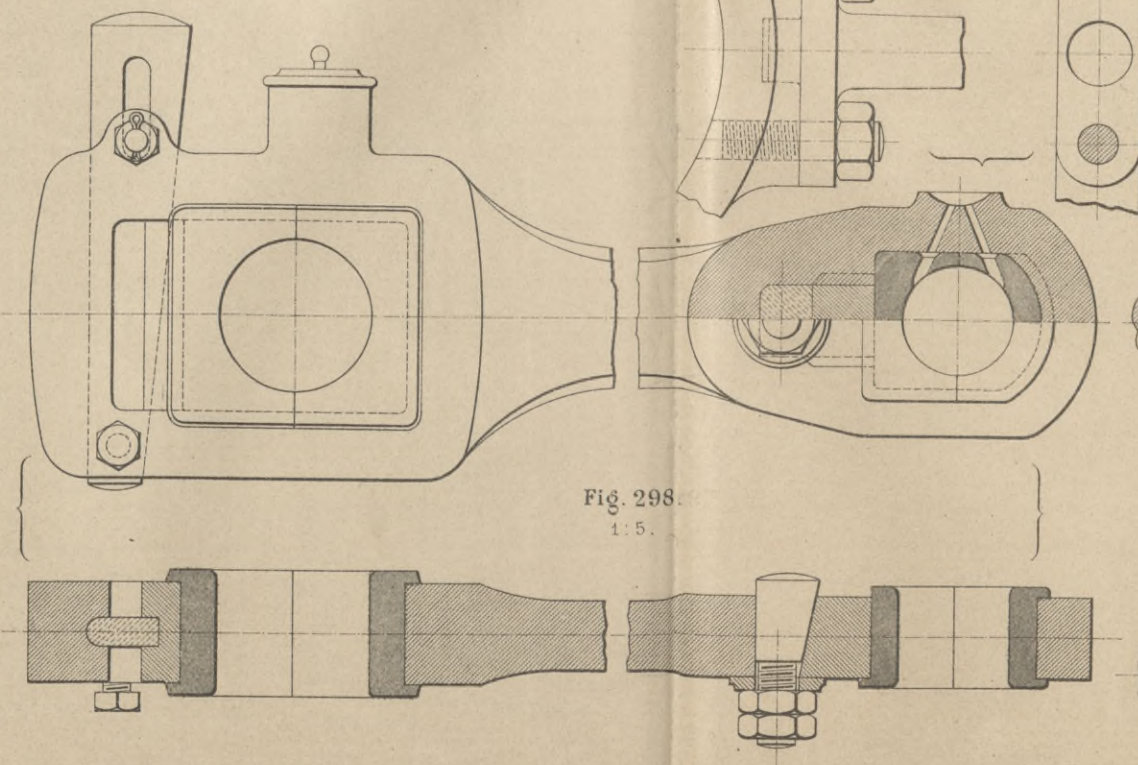
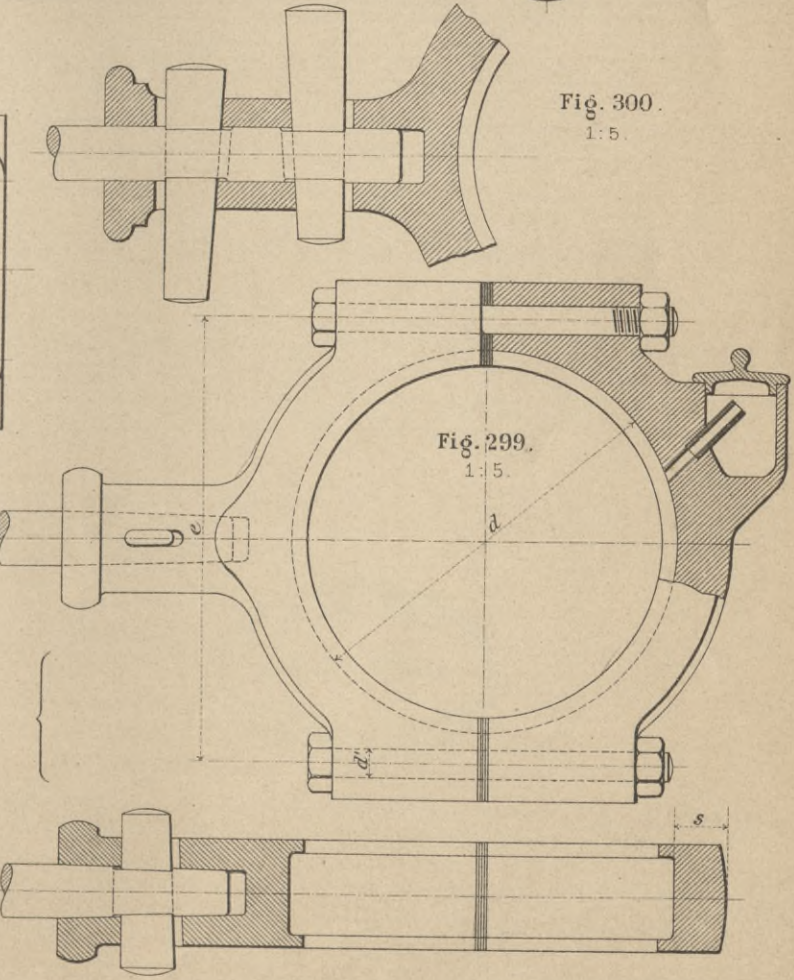
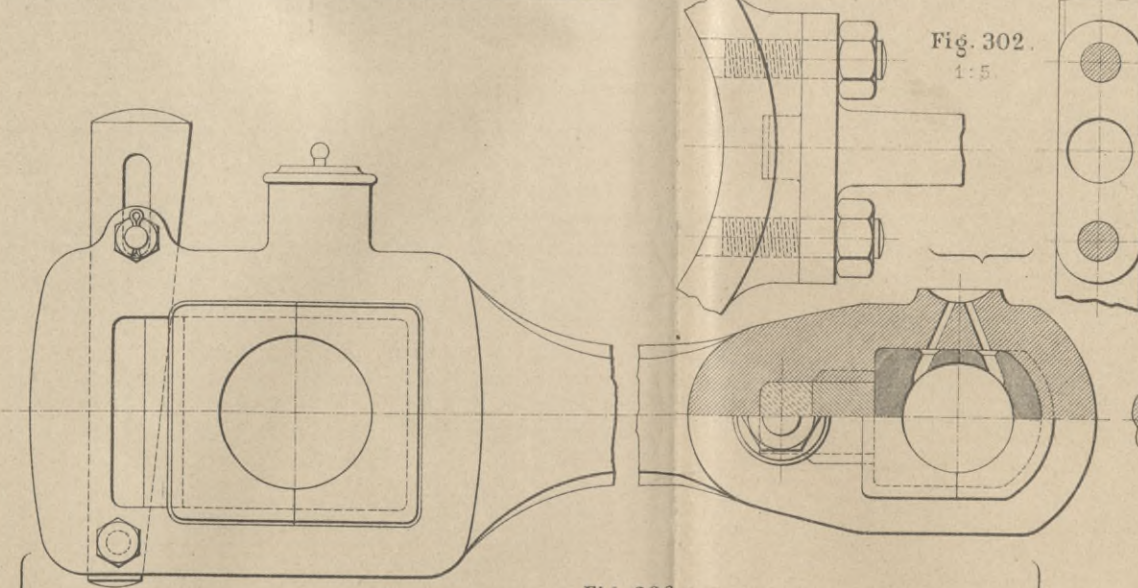
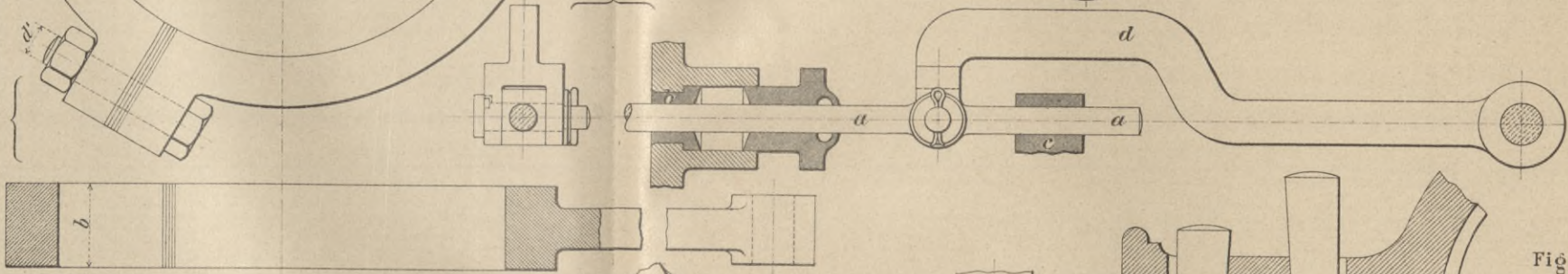
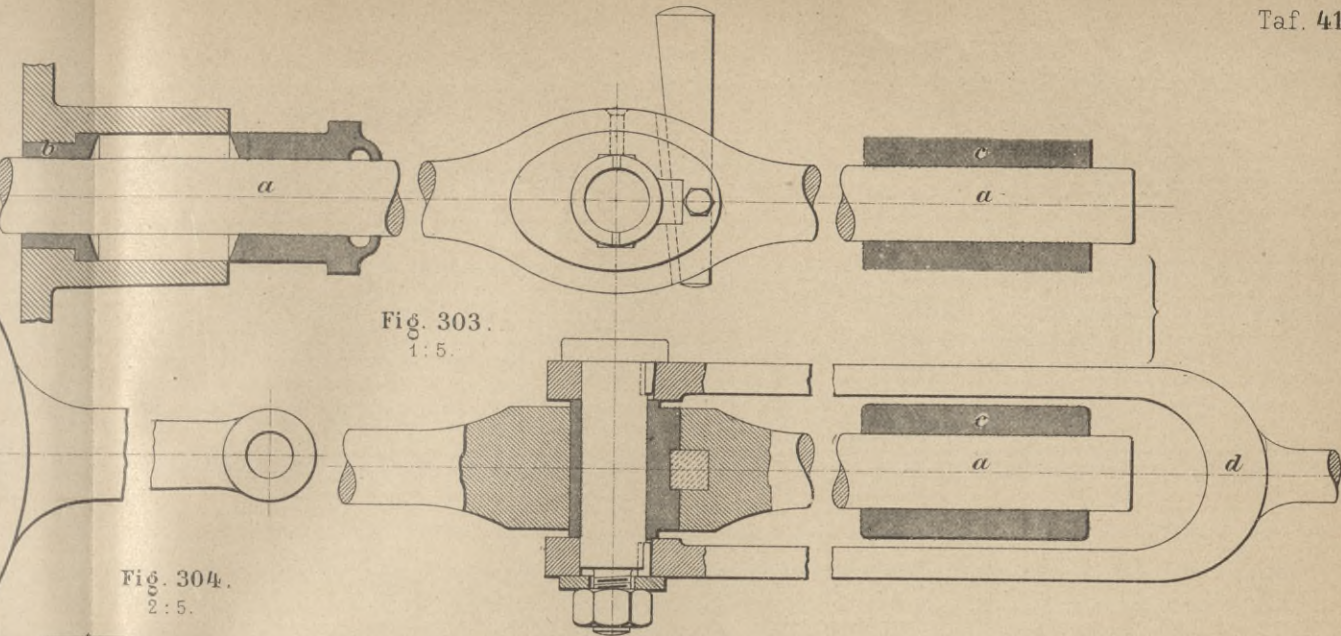
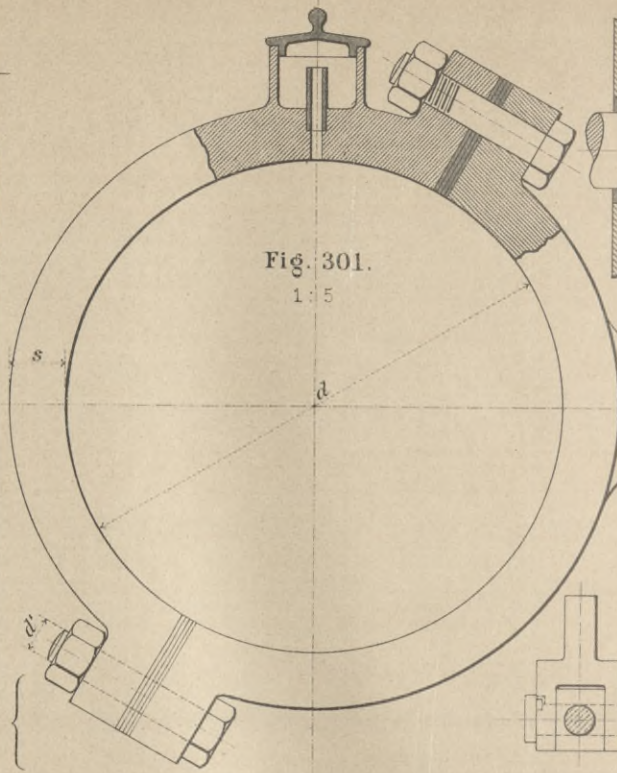
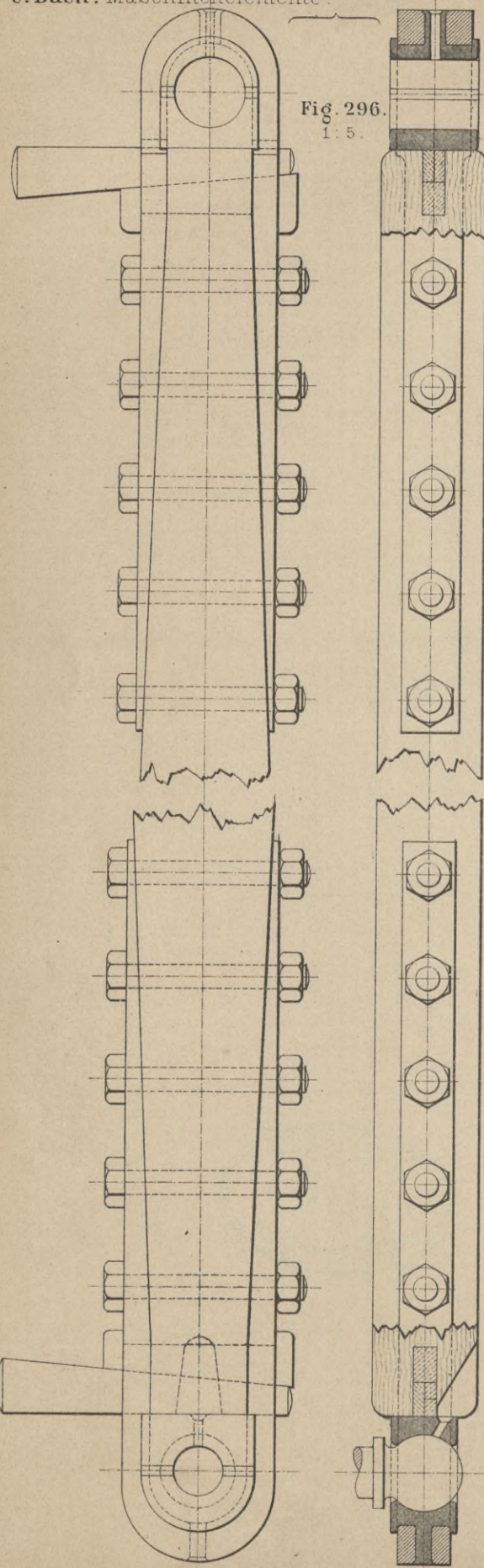


Fig. 286.
1:5.



Schnitt: a b c d.







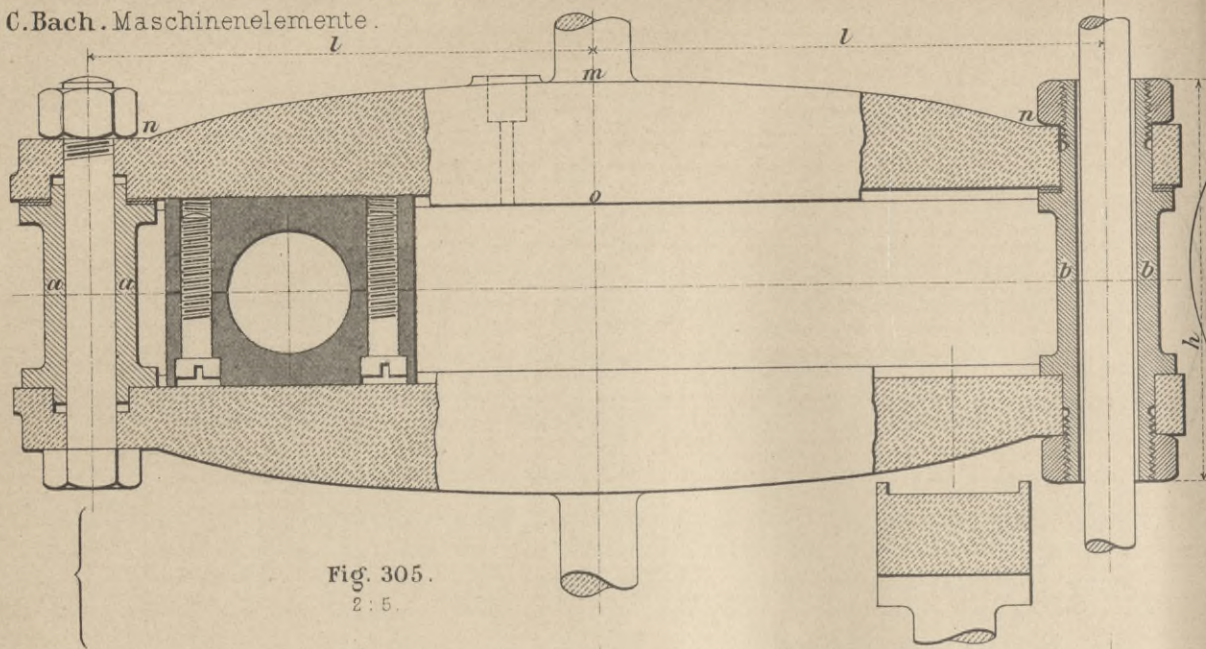


Fig. 305.
2:5.

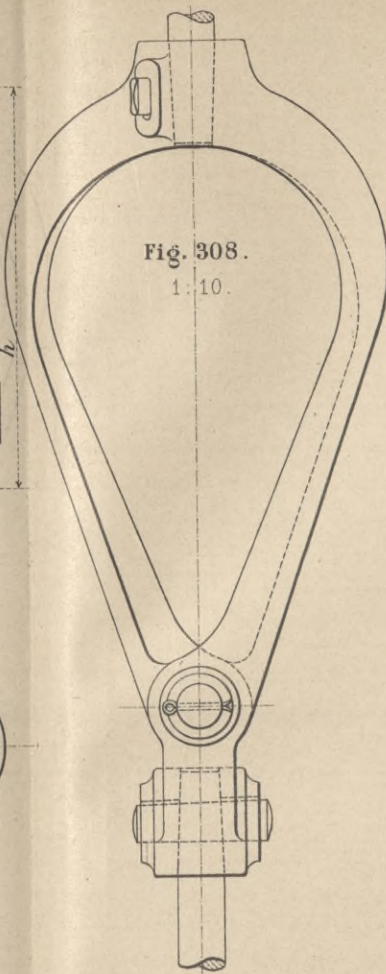
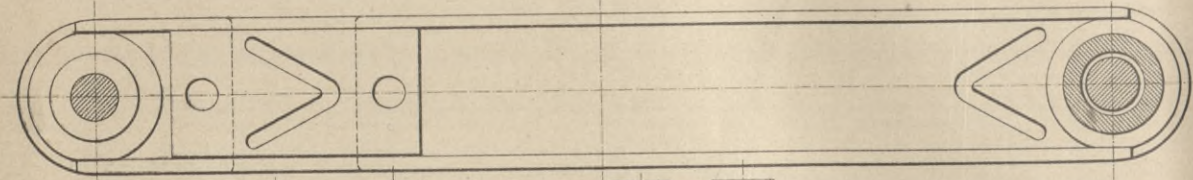


Fig. 308.
1:10.

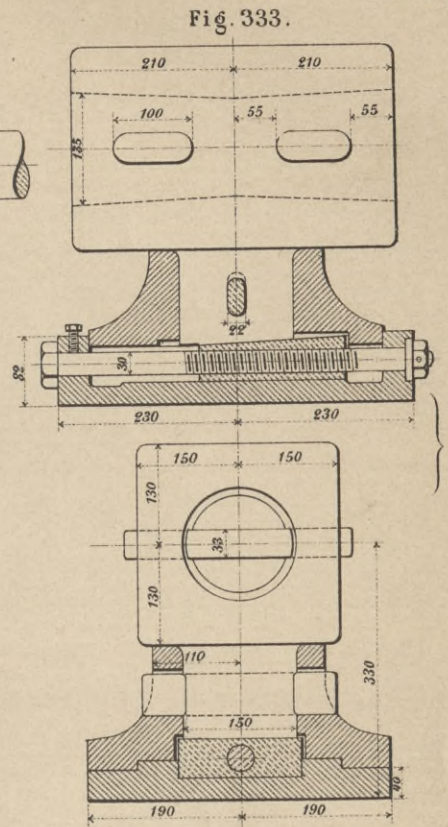
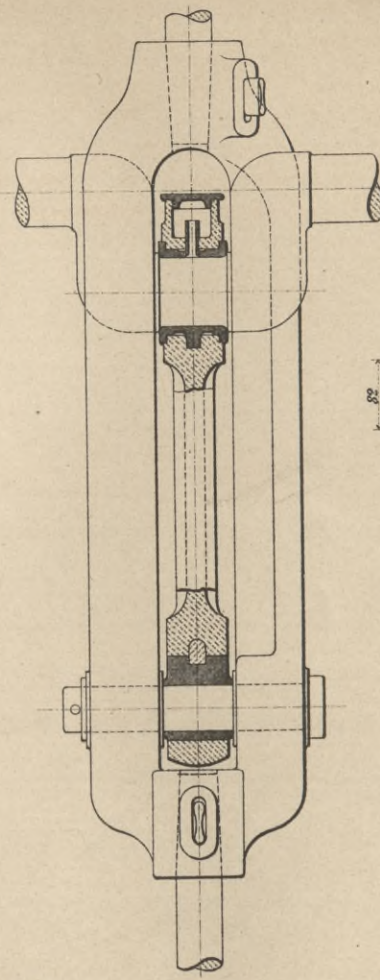


Fig. 333.

Fig. 307.
1:7.

Fig. 329.
1:10.

Schnitt: a b.

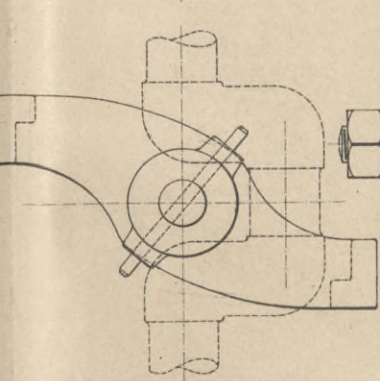
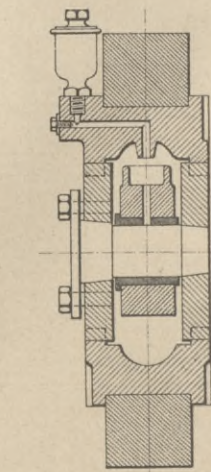
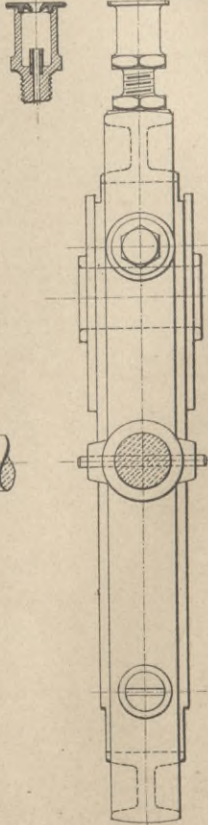
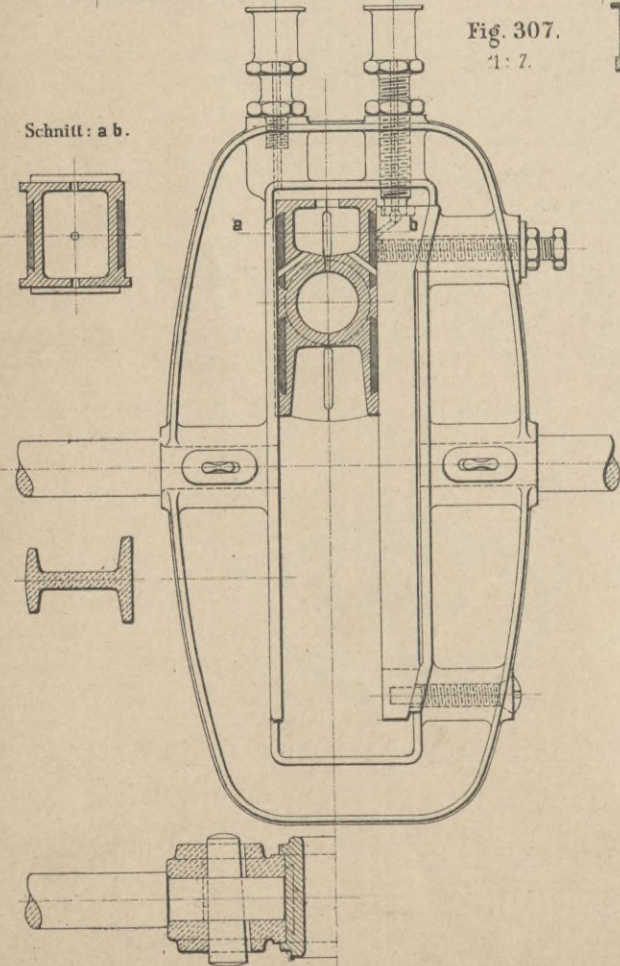


Fig. 306.
2:5.

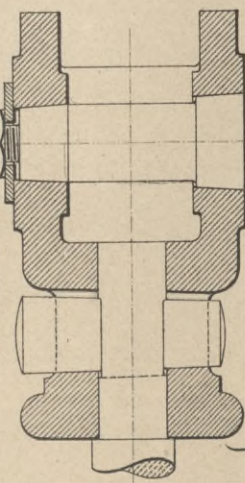
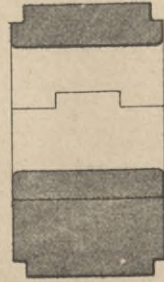
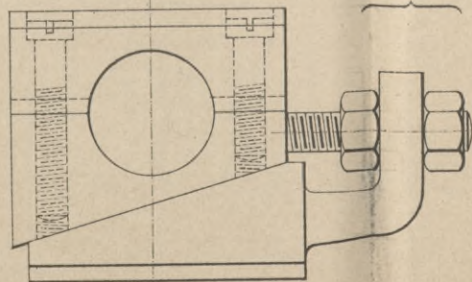


Fig. 328.
1:10.

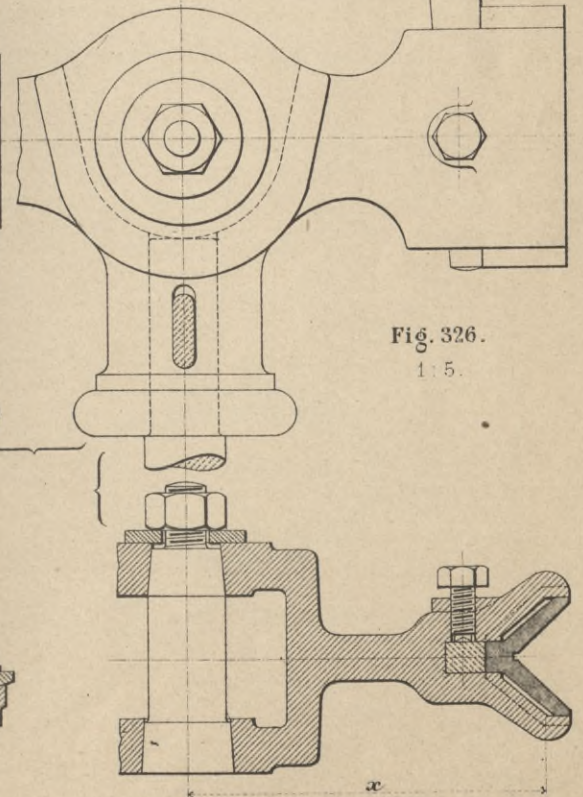
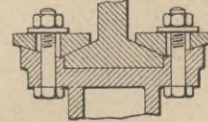


Fig. 326.
1:5.

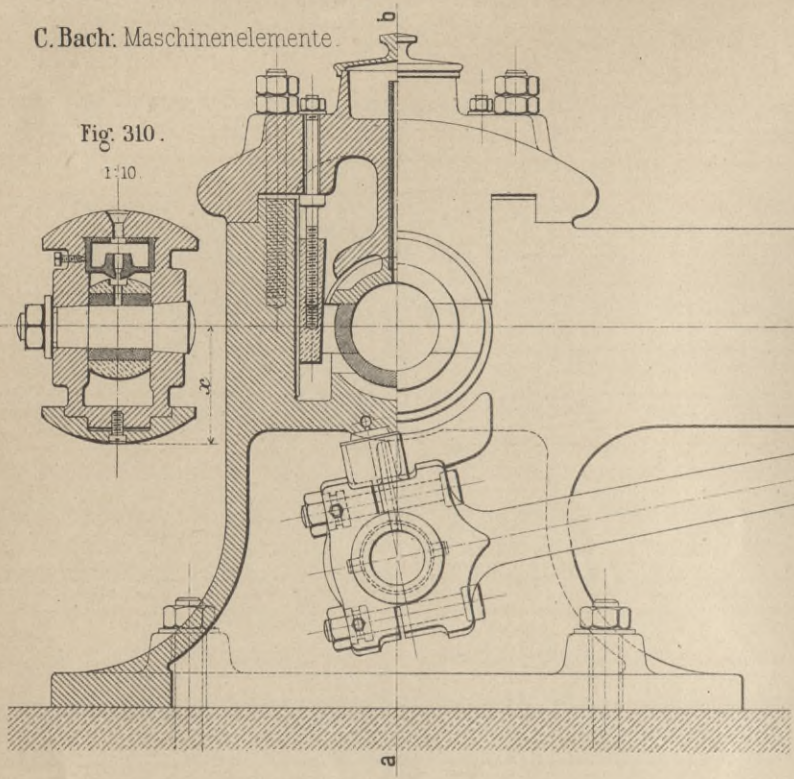
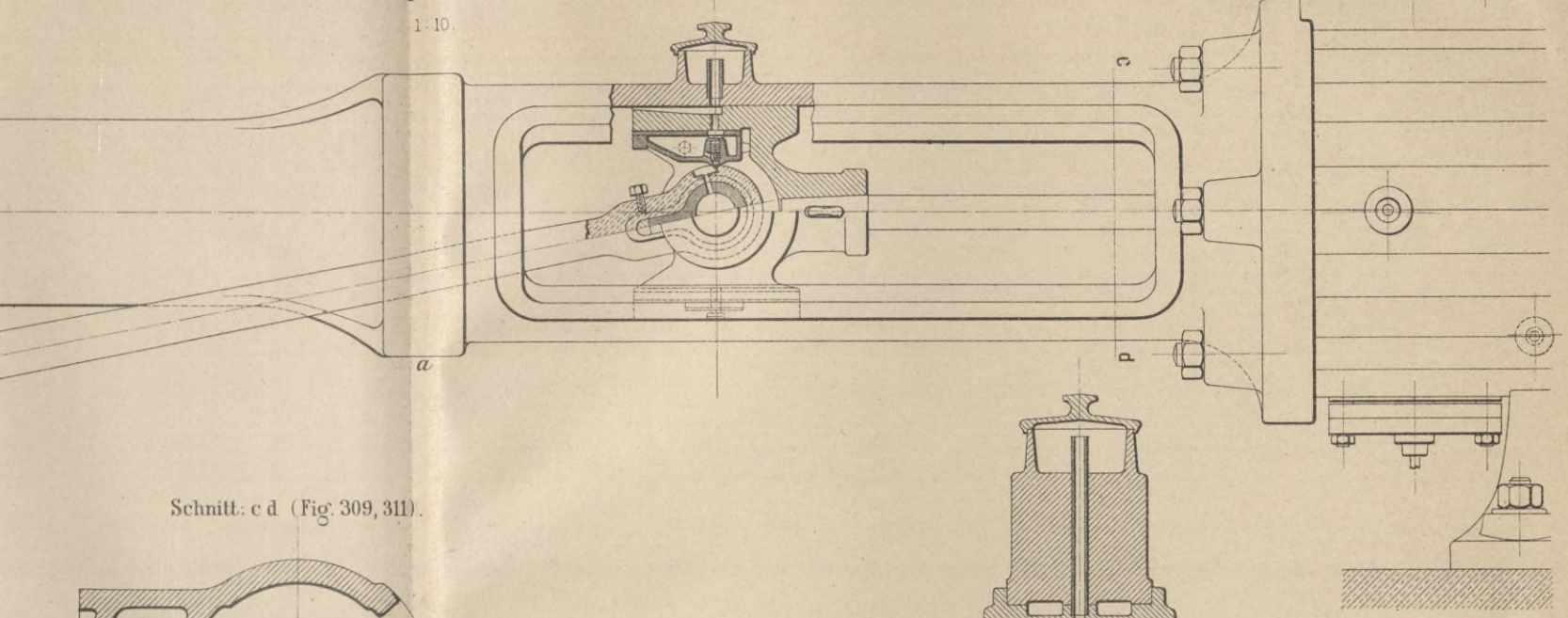


Fig. 309.

1:10.



Schnitt: c d (Fig. 309, 311).

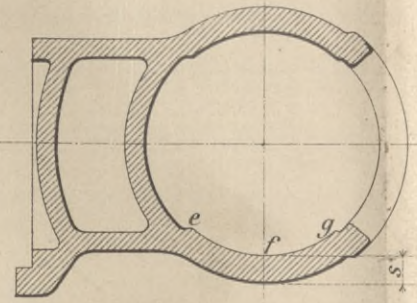
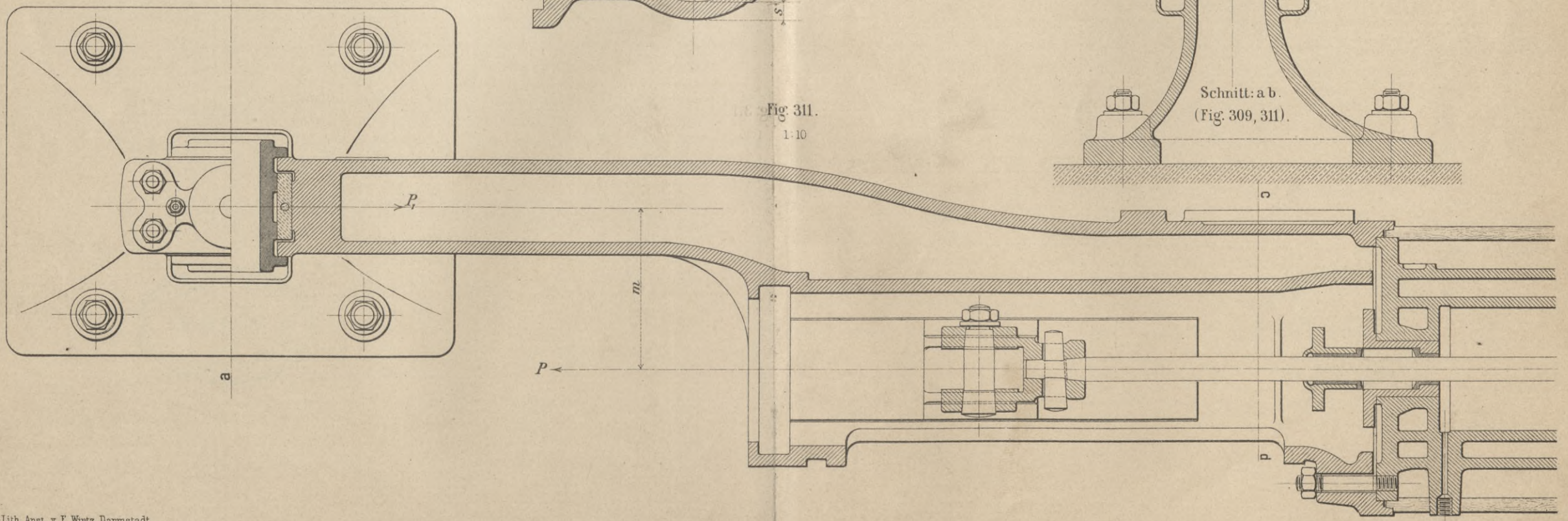


Fig. 311.

1:10



Schnitt: a b.
(Fig. 309, 311).



Fig. 313.

1:10.

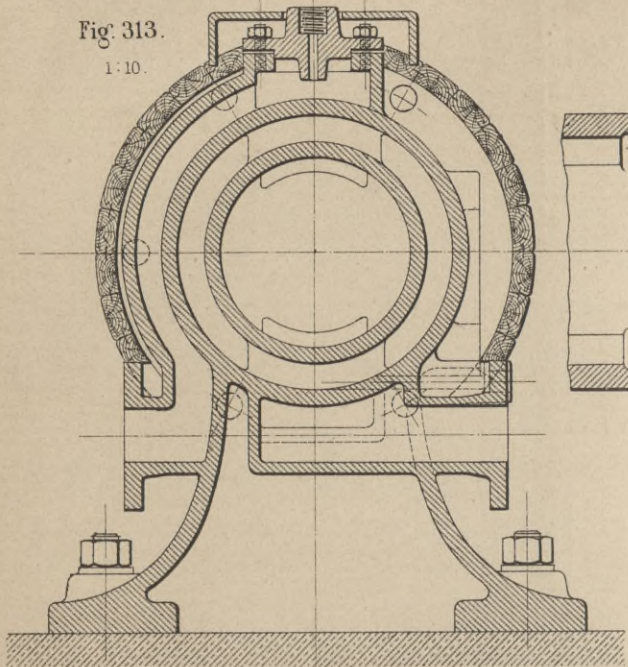


Fig. 312.

1:10.

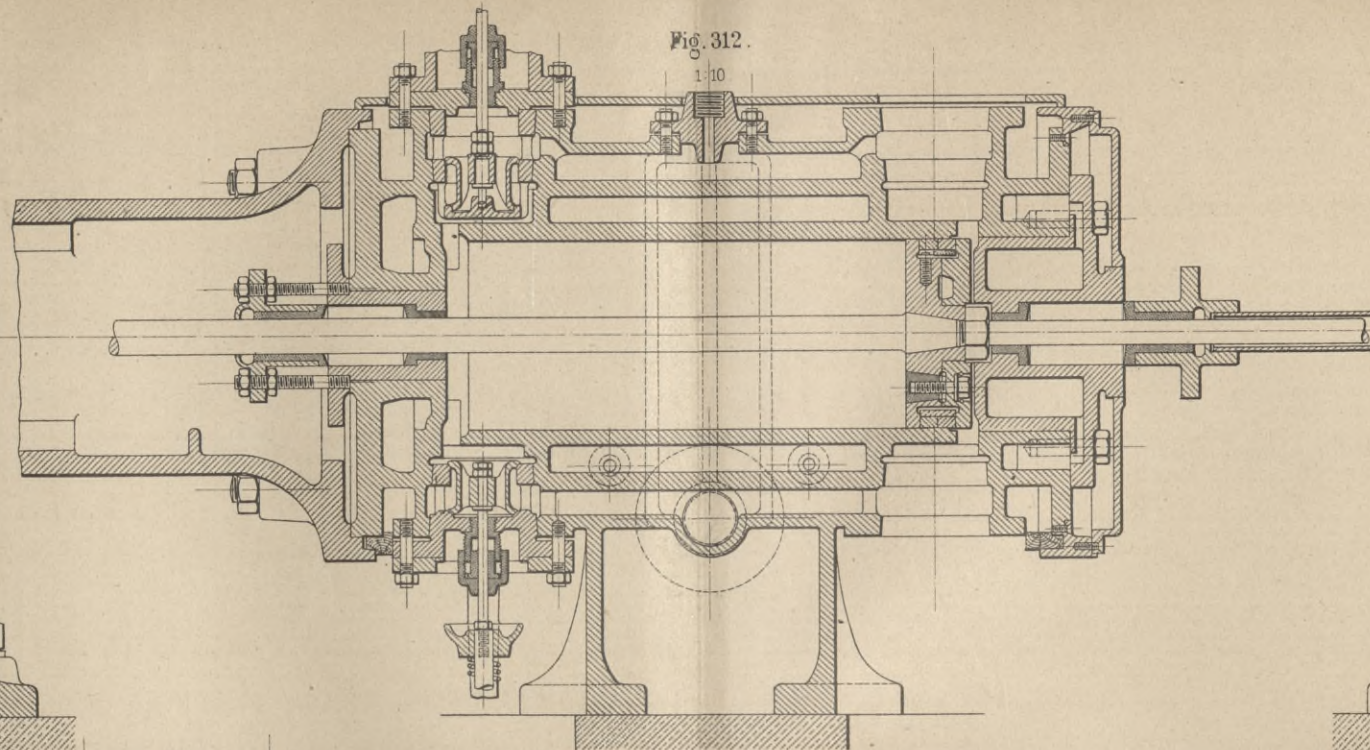


Fig. 314.

1:10.

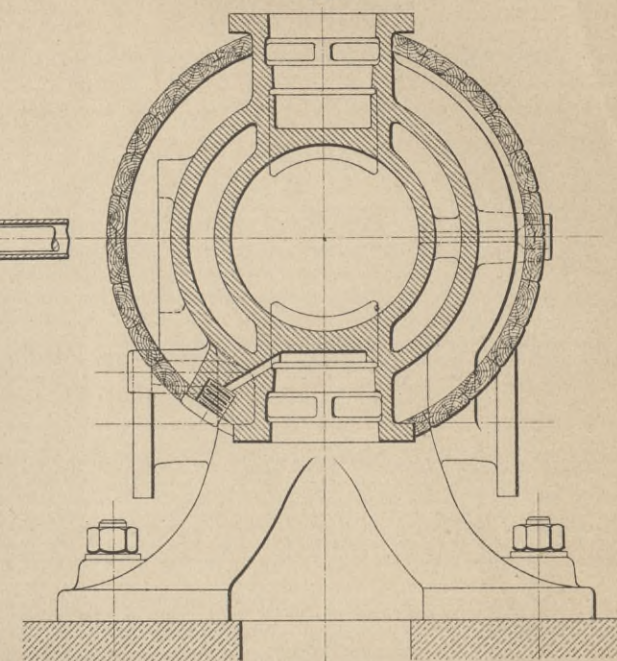


Fig. 348.

1:15.

Schnitt: a b.
In der Richtung des Pfeiles gesehen.

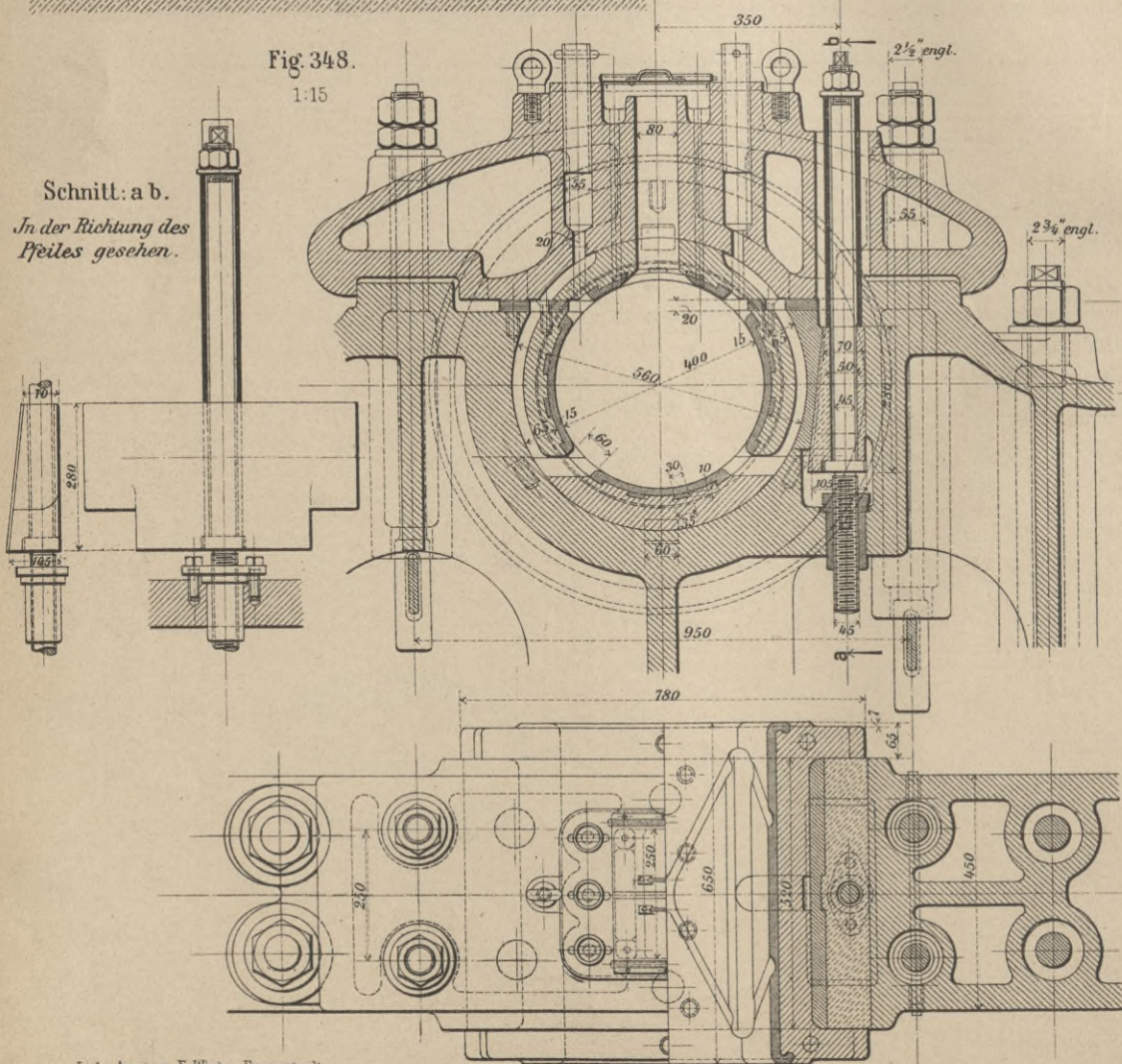


Fig. 327.

1:10.

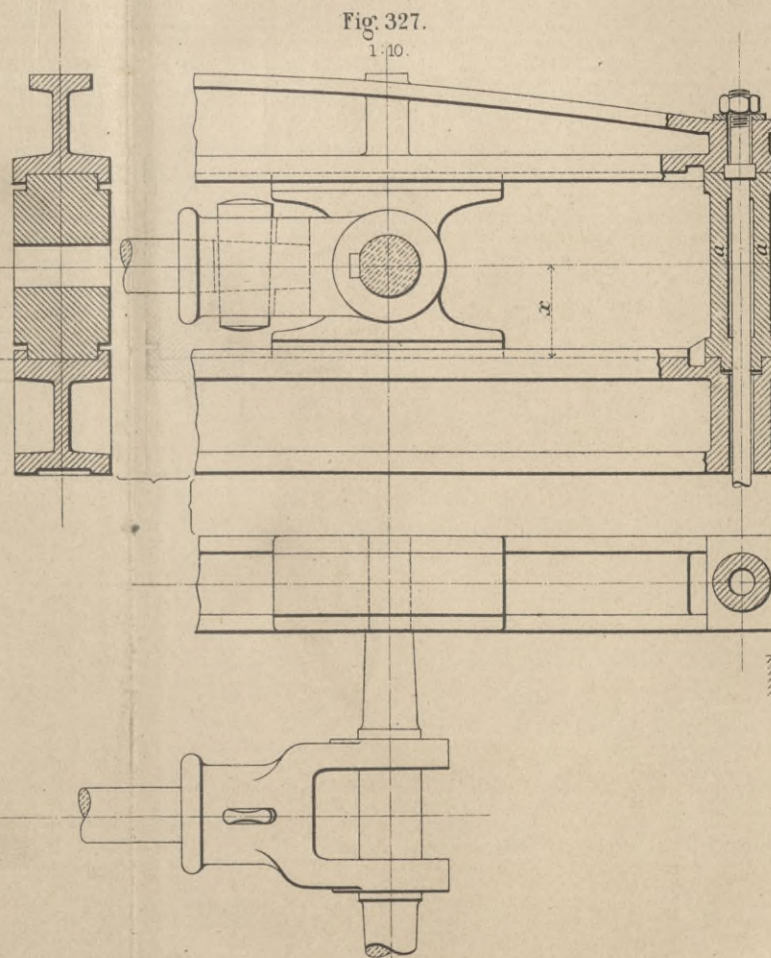


Fig. 315.

1:10.

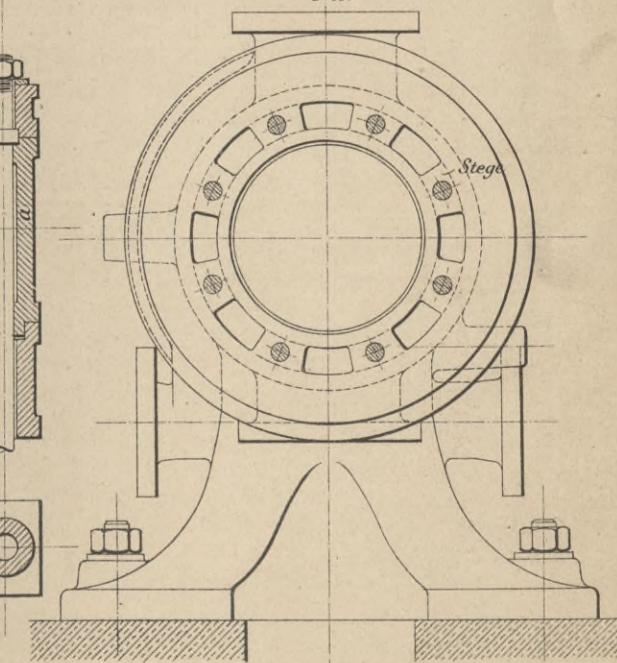




Fig. 316.
1:10.

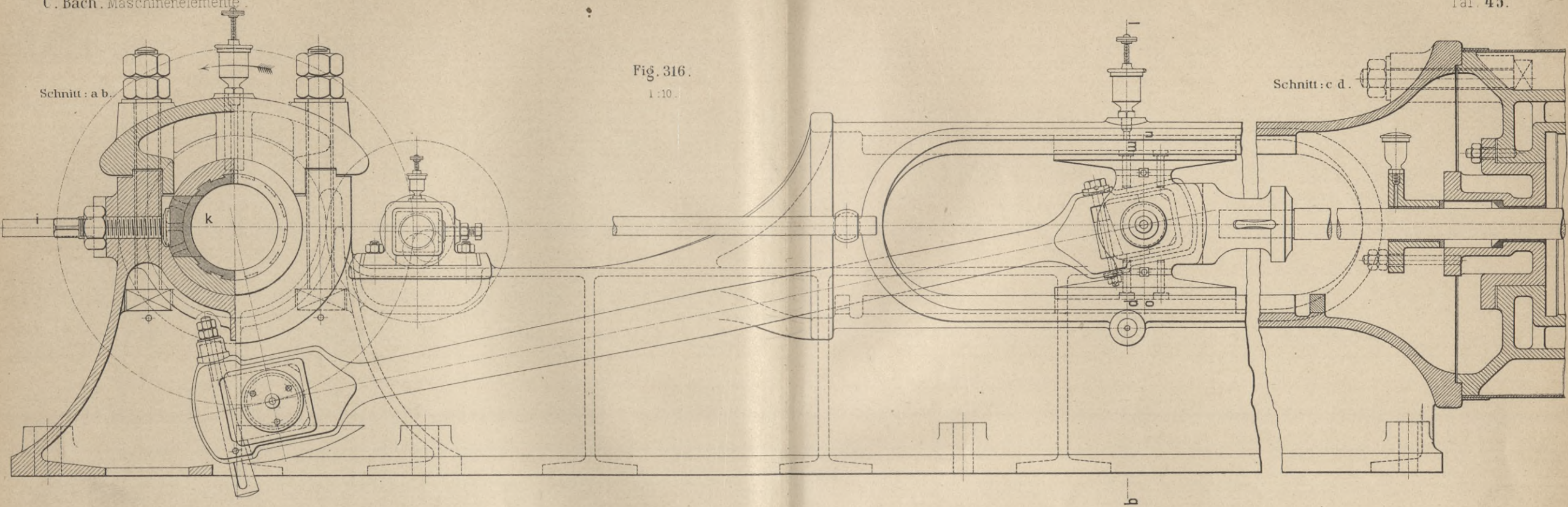


Fig. 317.
1:10.

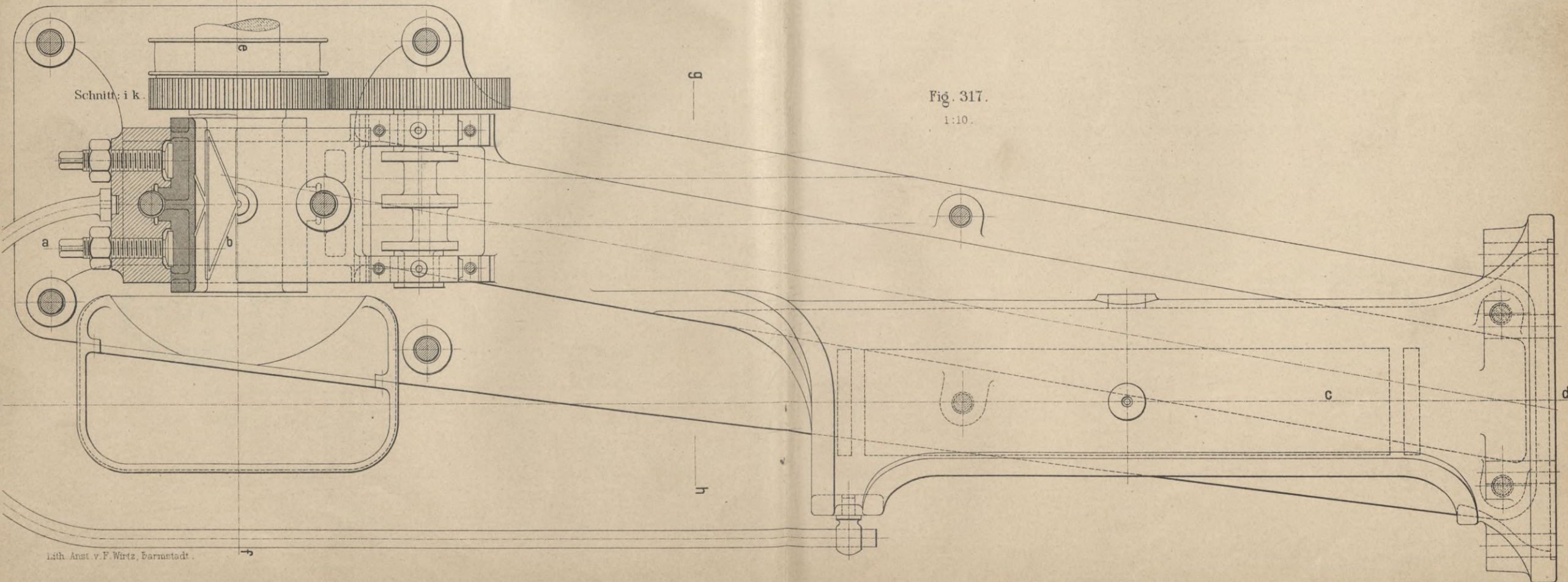




Fig. 318.

1:10.

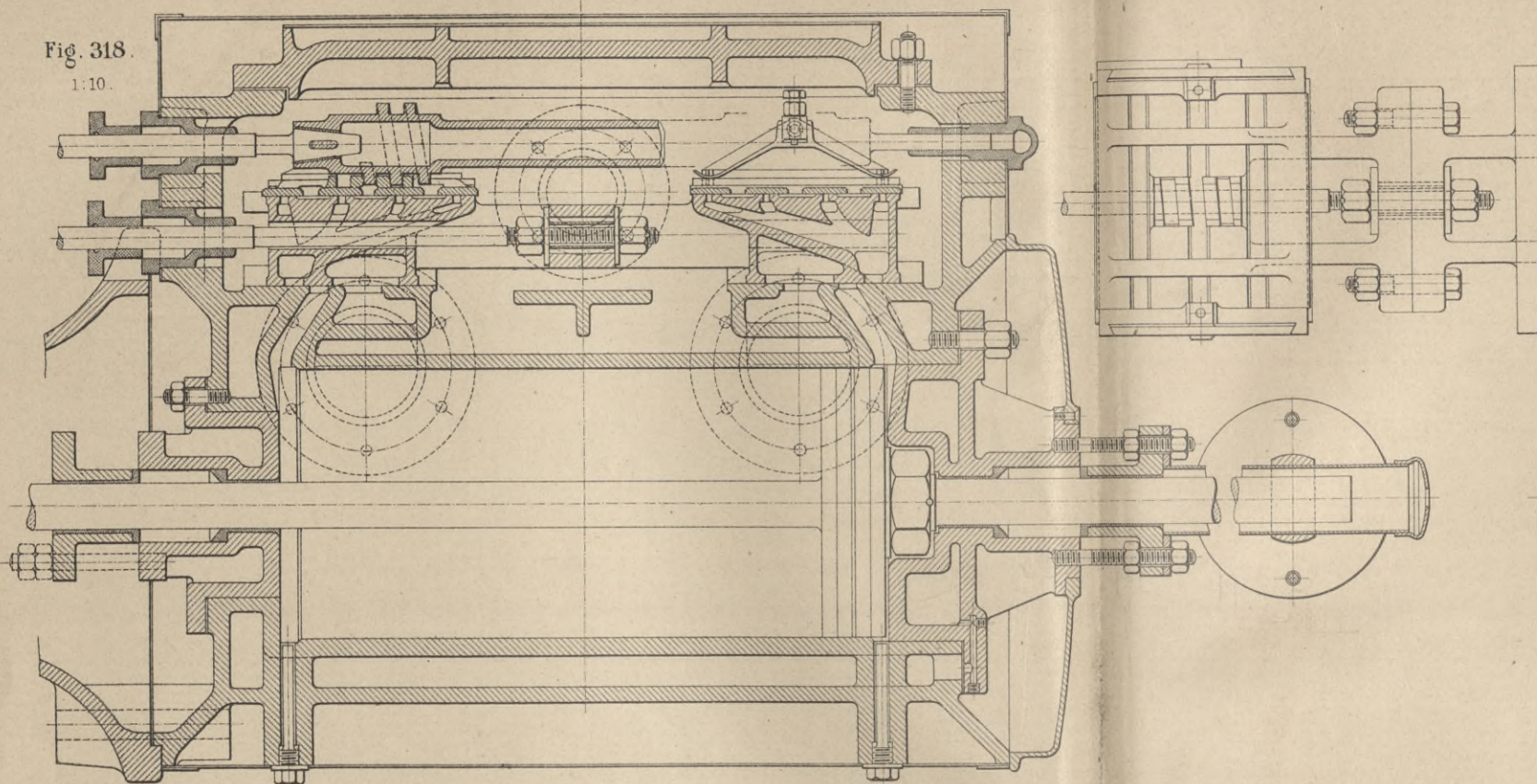


Fig. 319.

1:10.

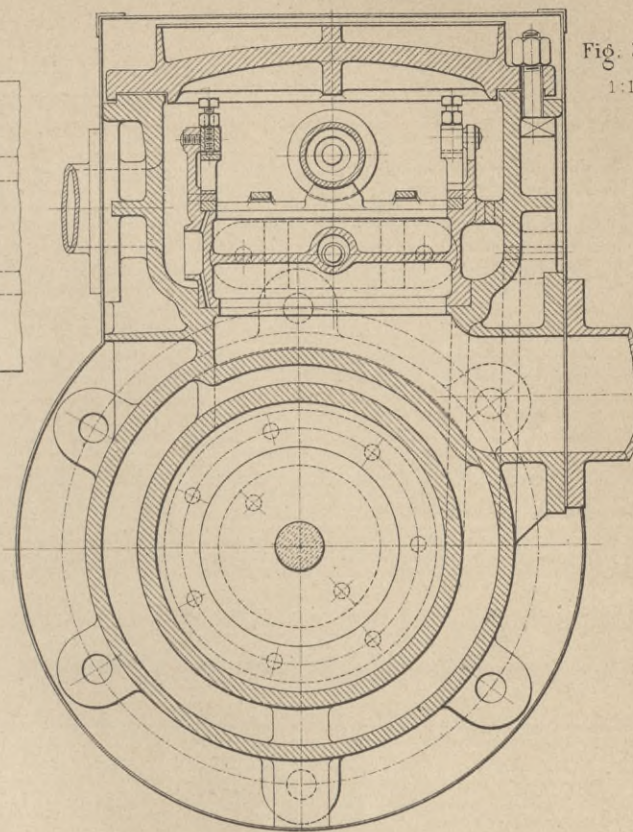


Fig. 320.

1:10.

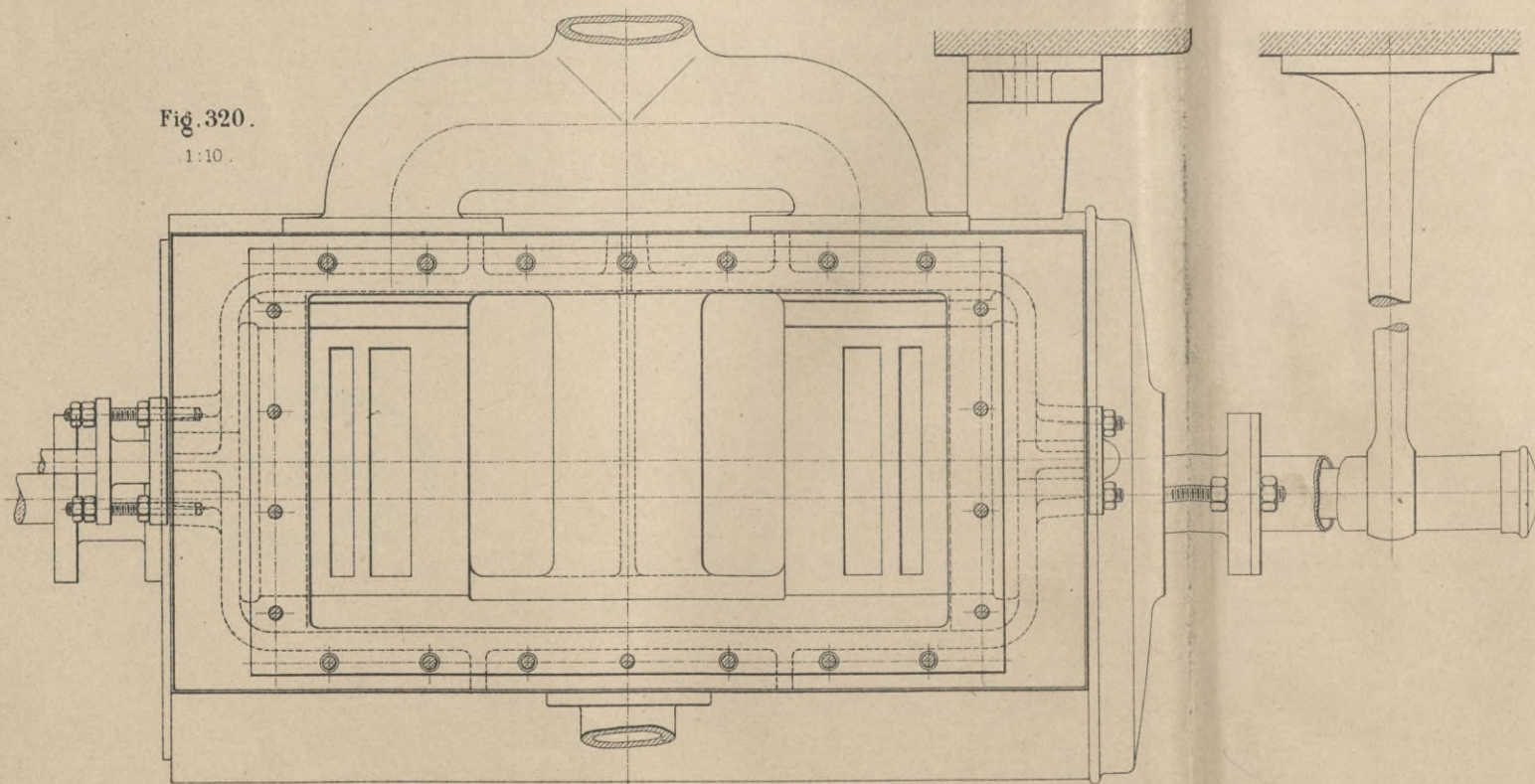


Fig. 321.

1:10.

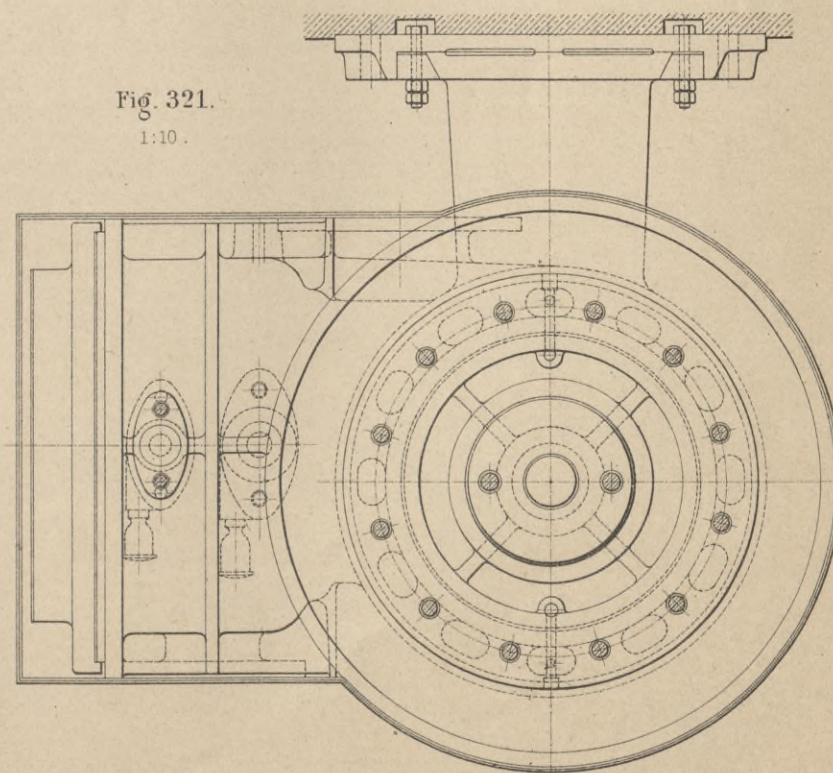




Fig. 322.
1:10.

Schnitt: e f (Fig. 317, Taf. 45) ohne Trog am Lagerfuß.

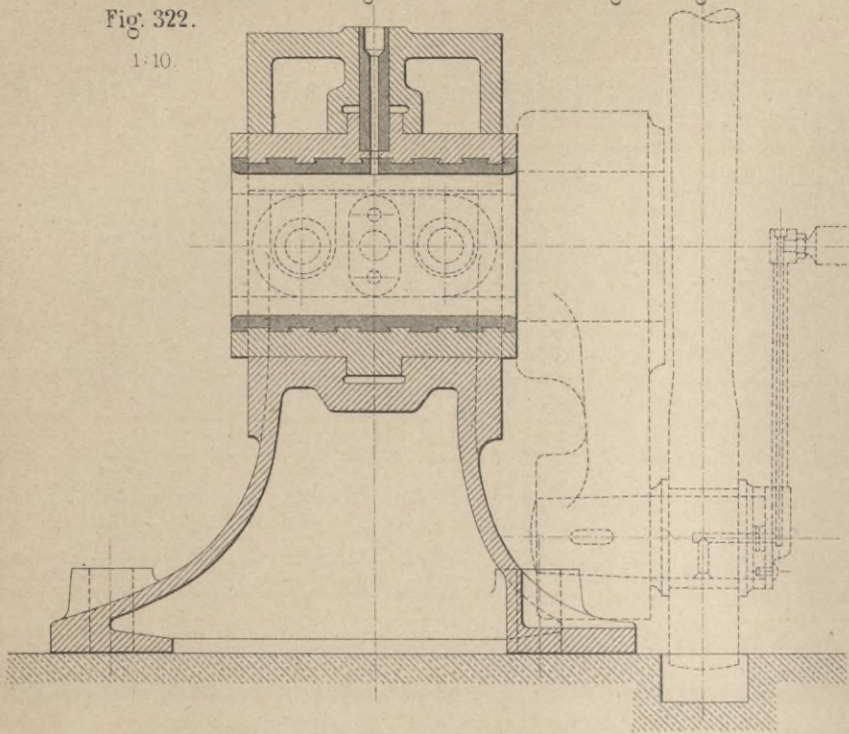


Fig. 323.
1:10.

Schnitt: l m, n o, p q.
(Fig. 316, Taf. 45).

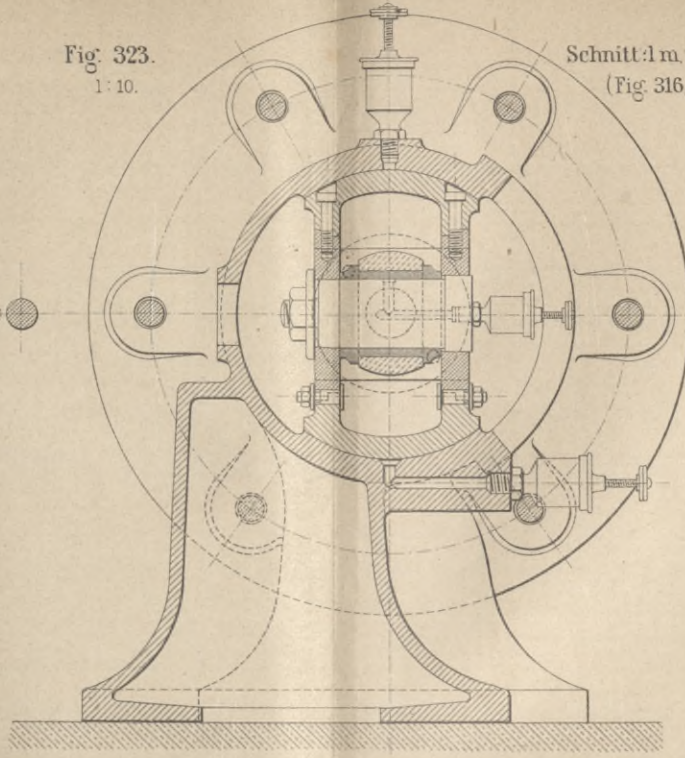
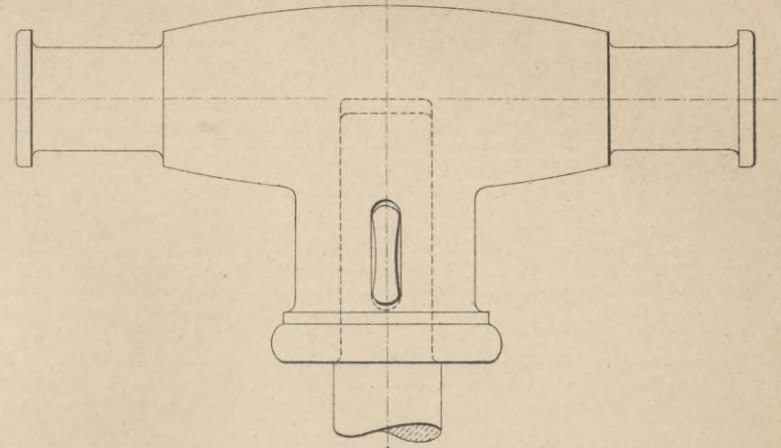
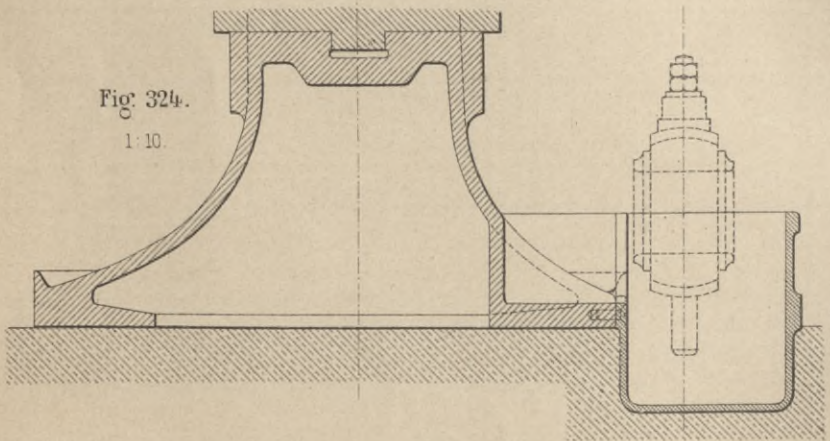


Fig. 336.
1:5.



Schnitt: e f mit Trog am Lagerfuß.

Fig. 324.
1:10.



Schnitt: g h (Fig. 317, Taf. 45).

Fig. 325.
1:10.

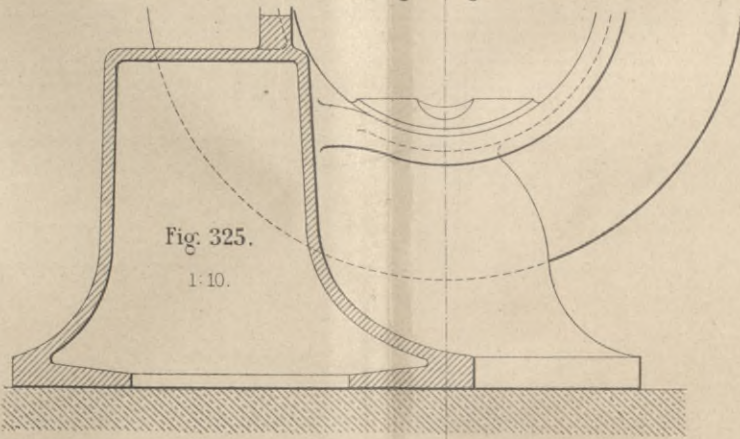


Fig. 337.
1:5.

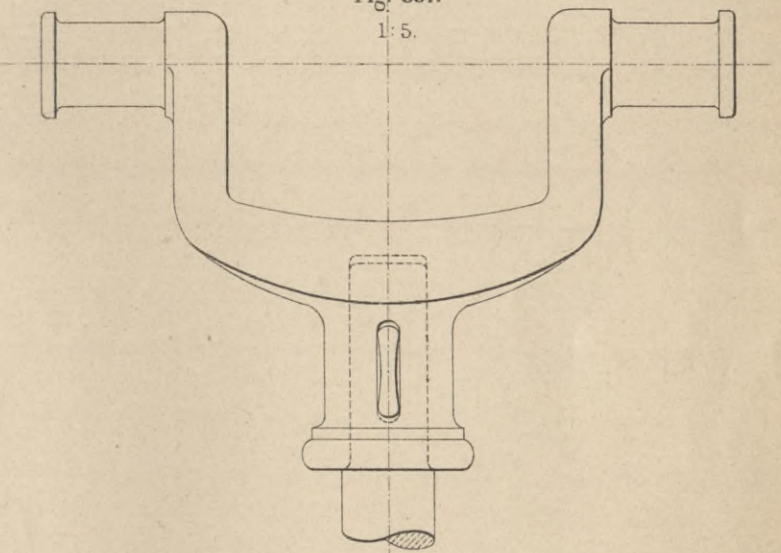


Fig. 331.
1:5.

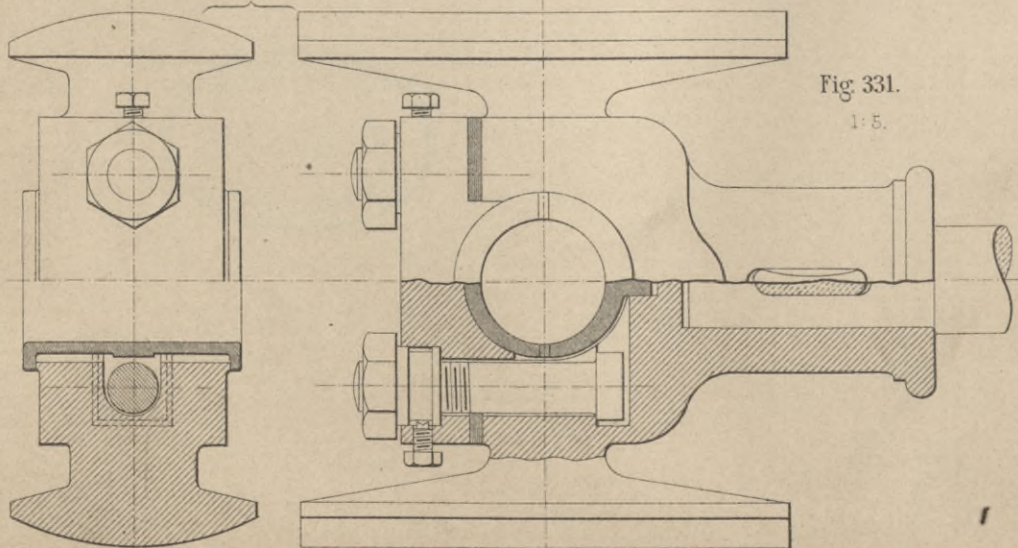
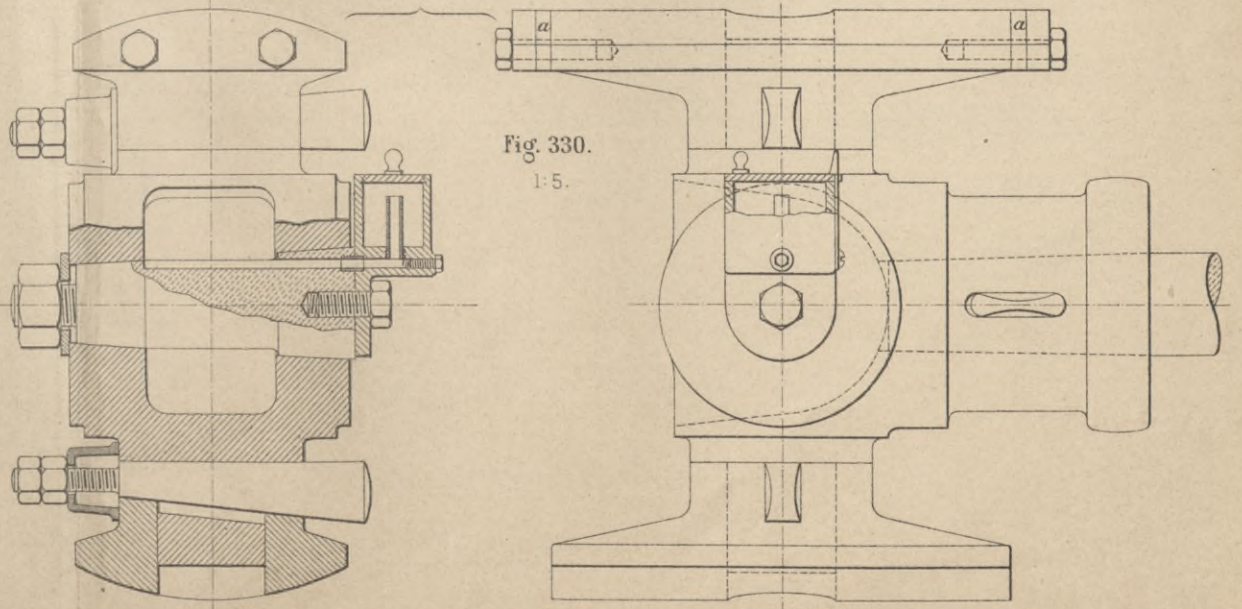
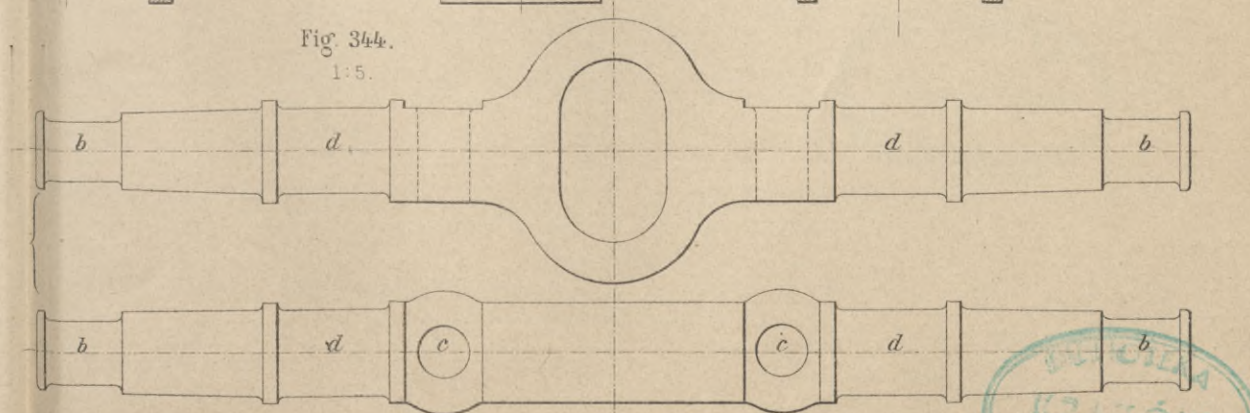
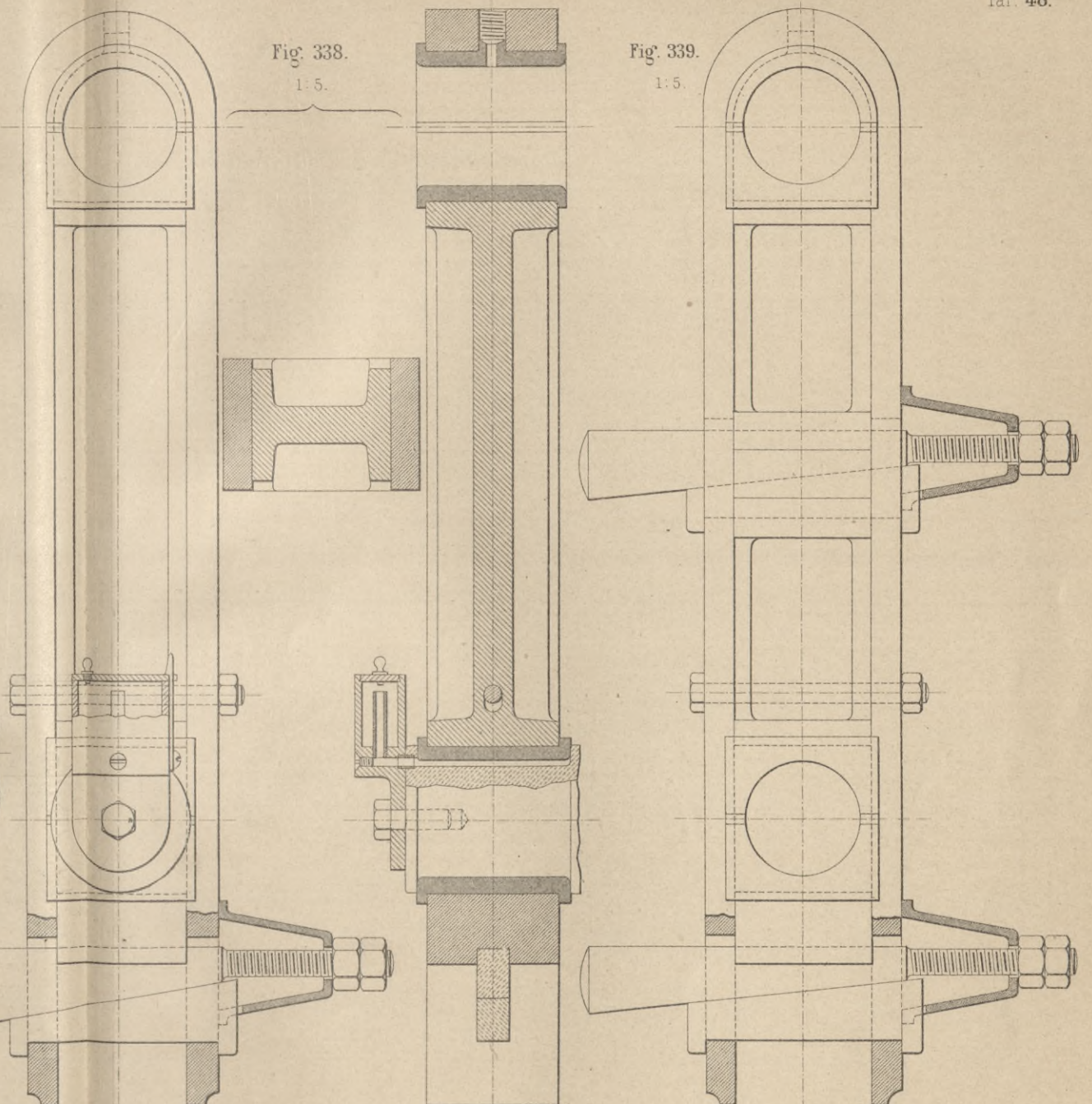
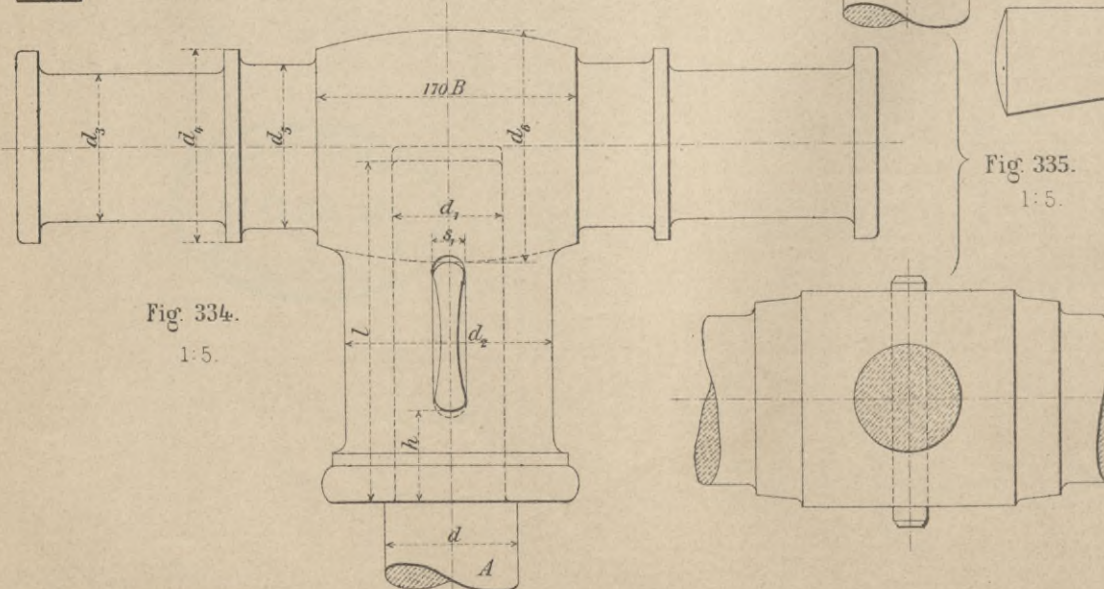
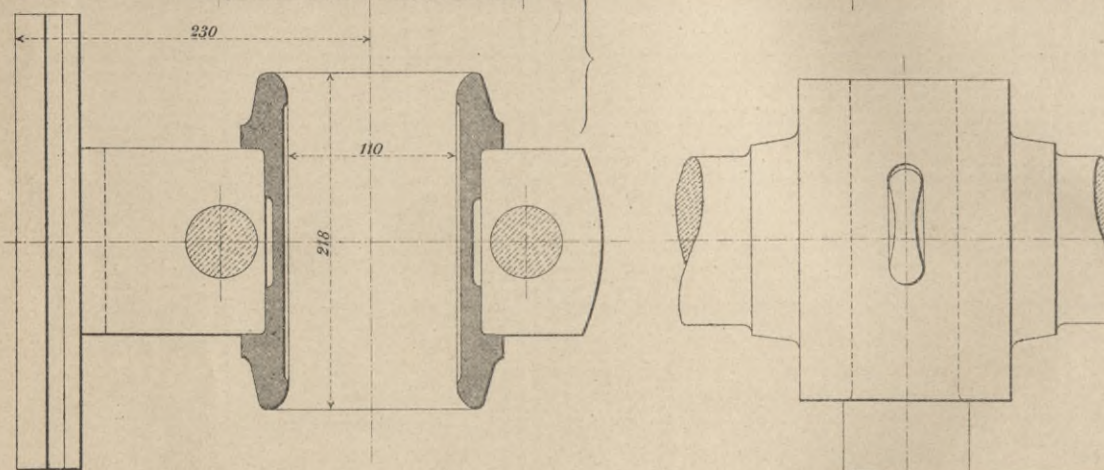
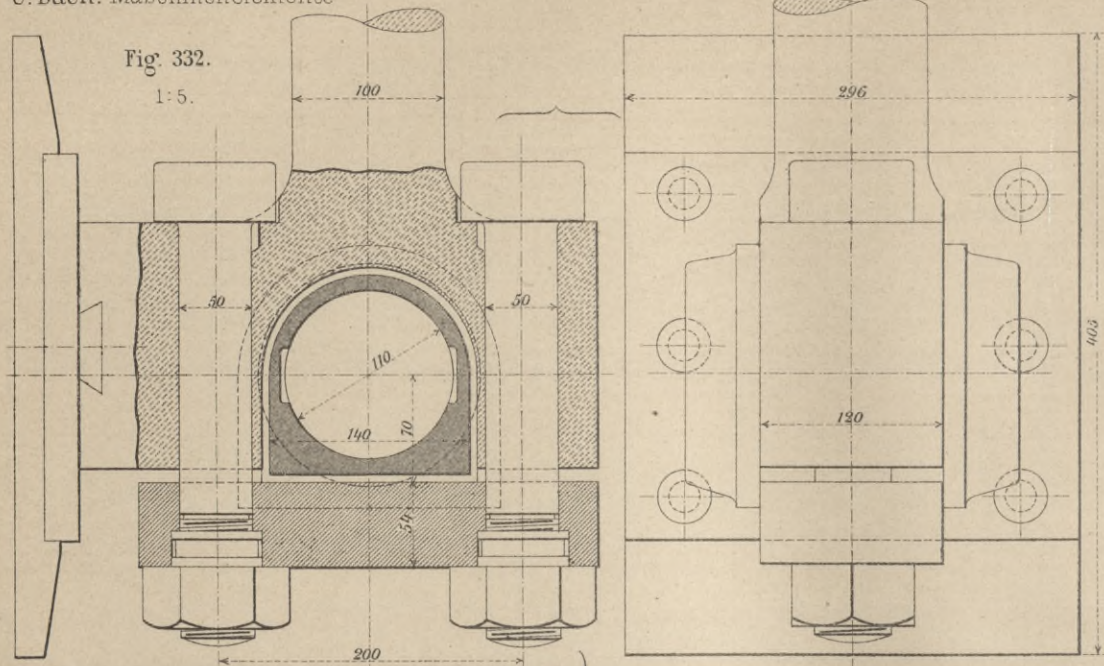


Fig. 330.
1:5.







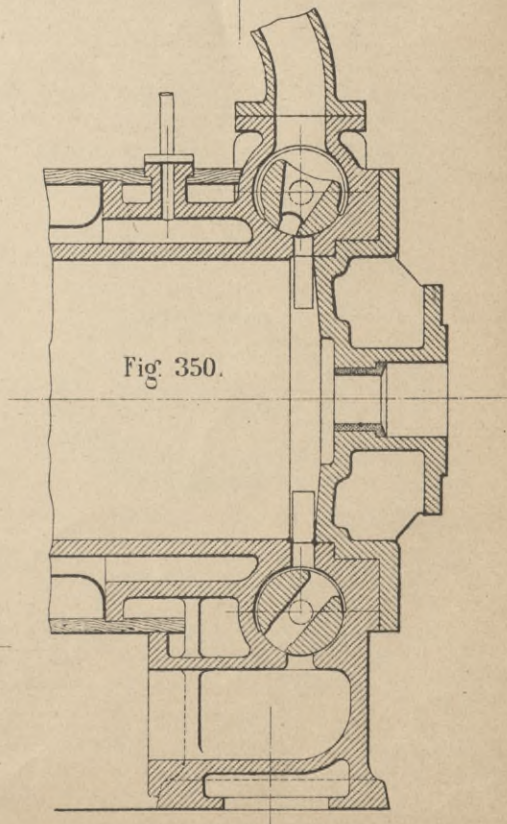
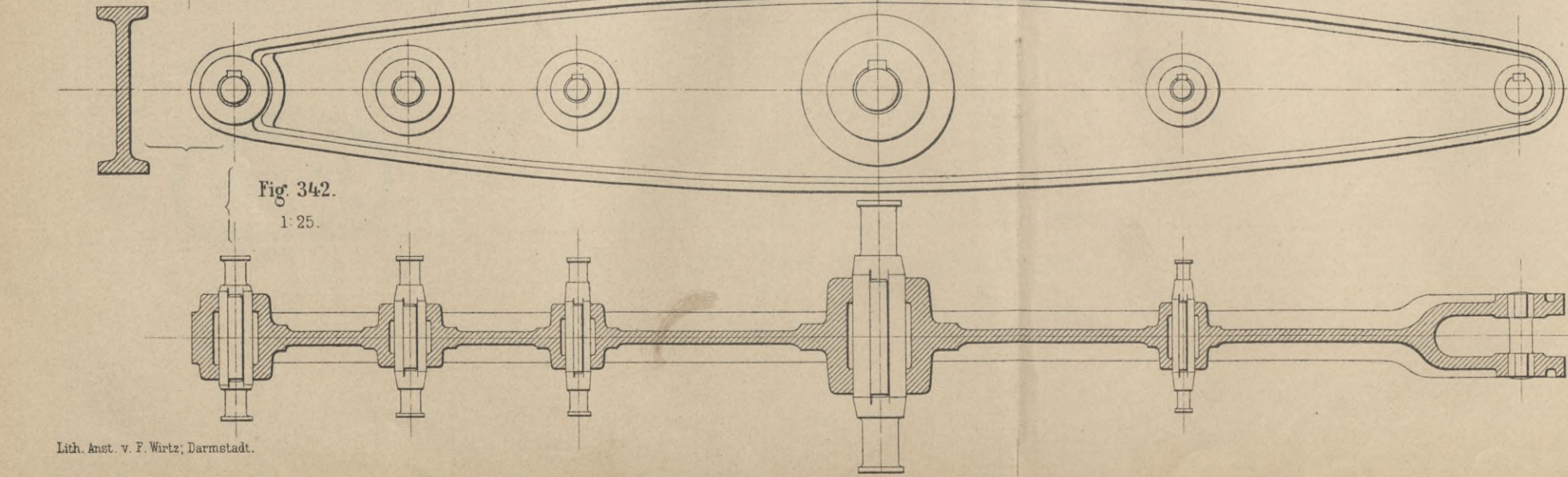
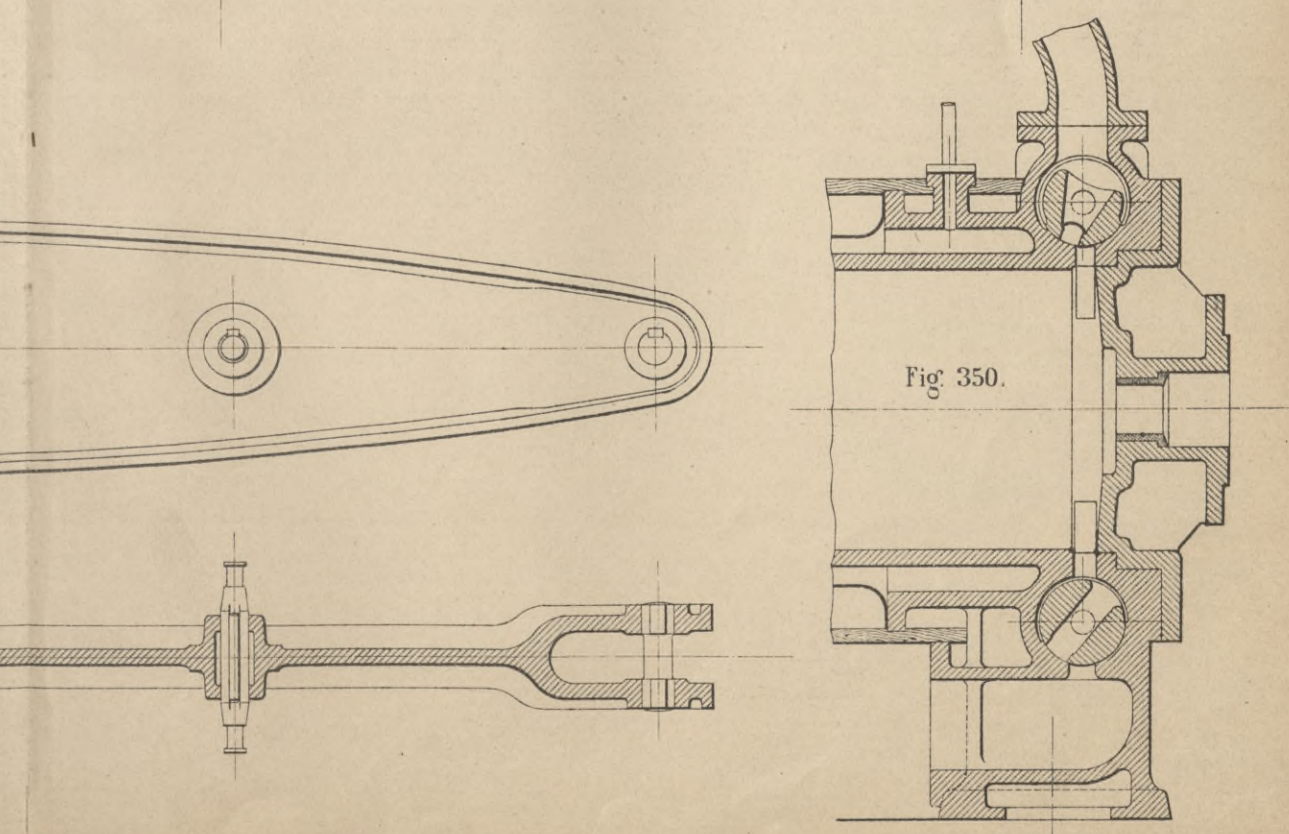
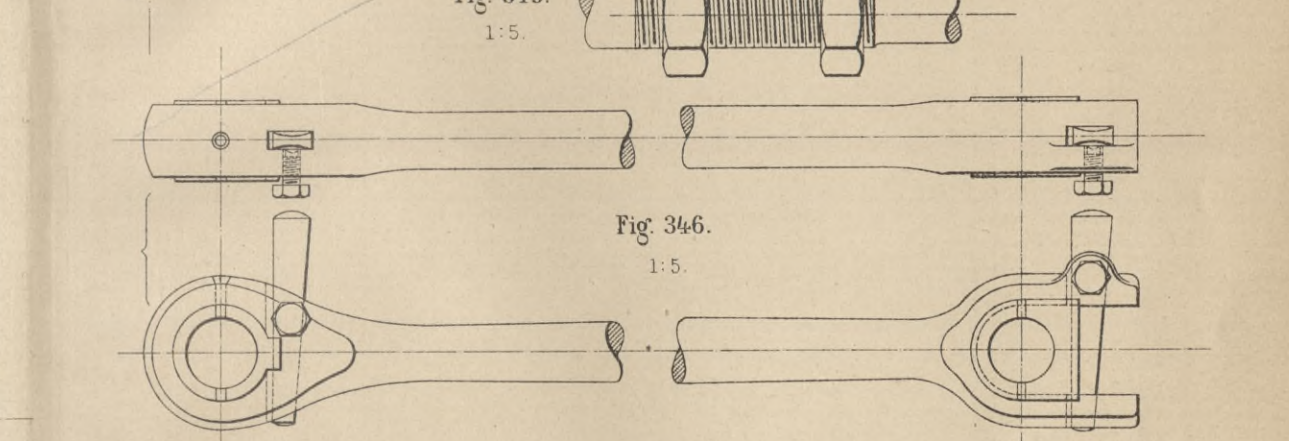
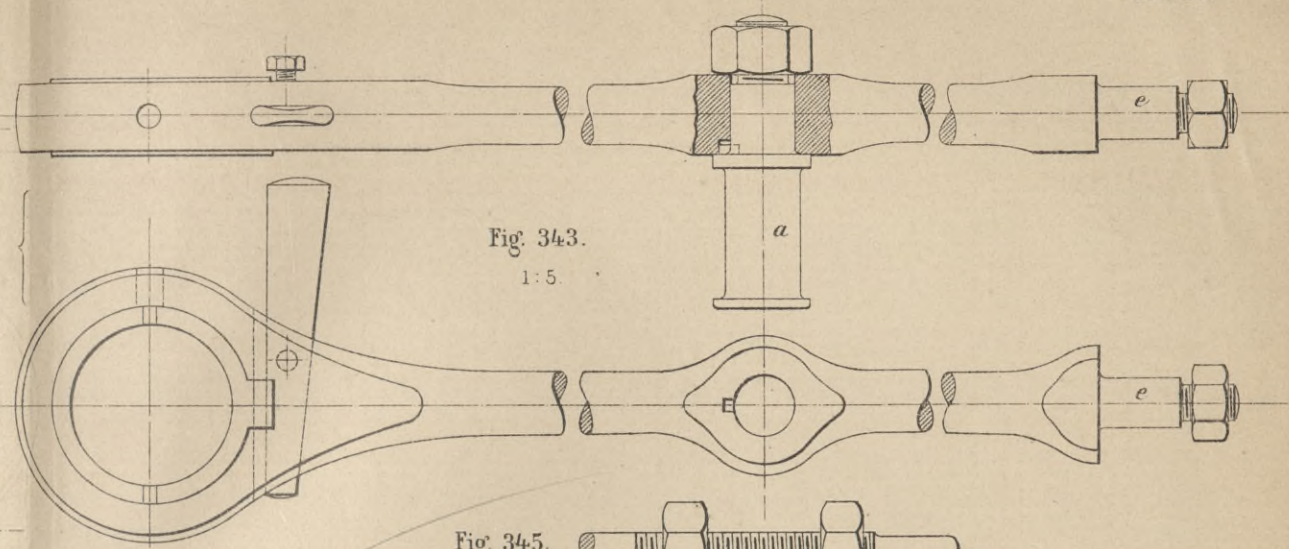
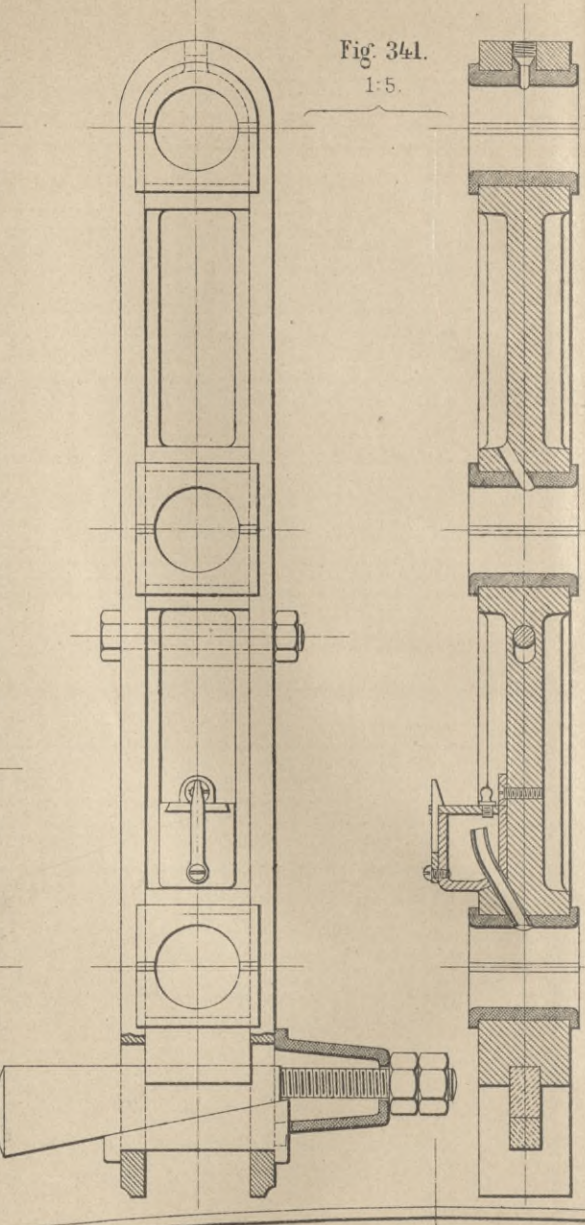
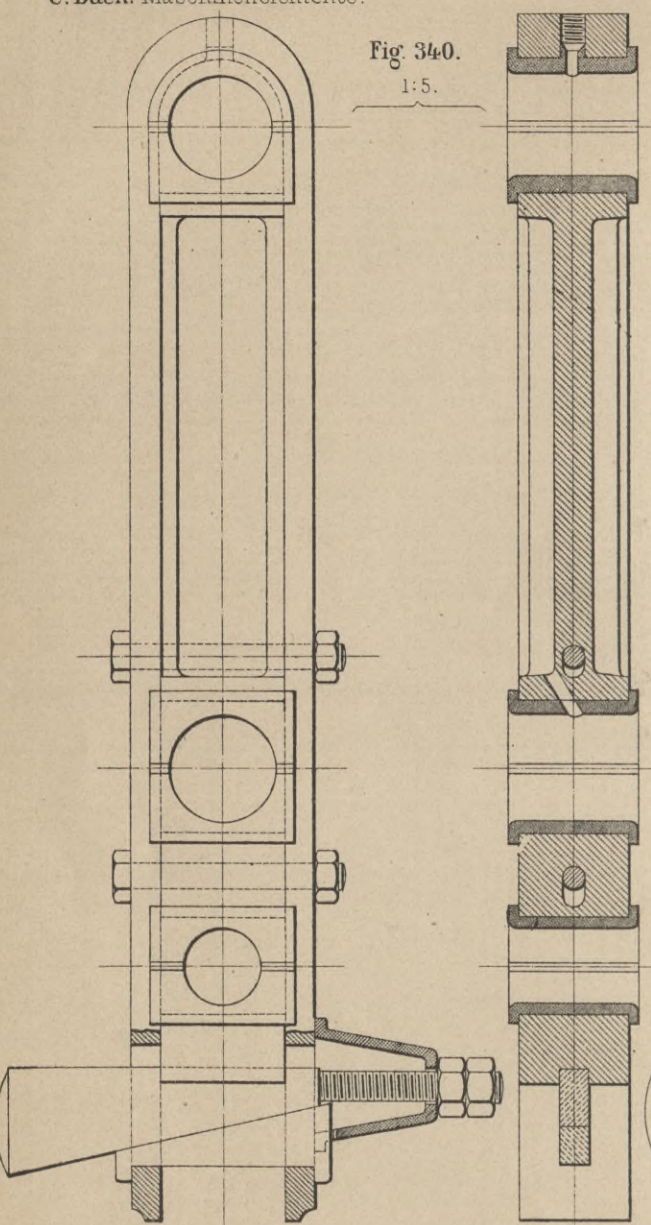




Fig. 351.

1:5.

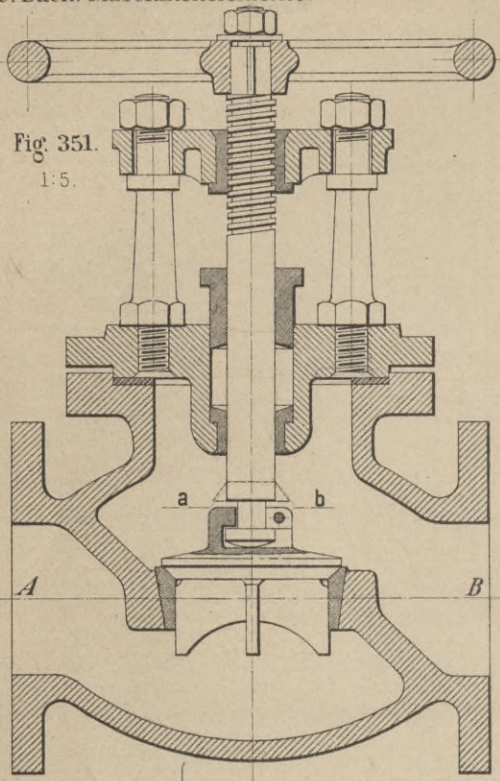


Fig. 352.

1:5.

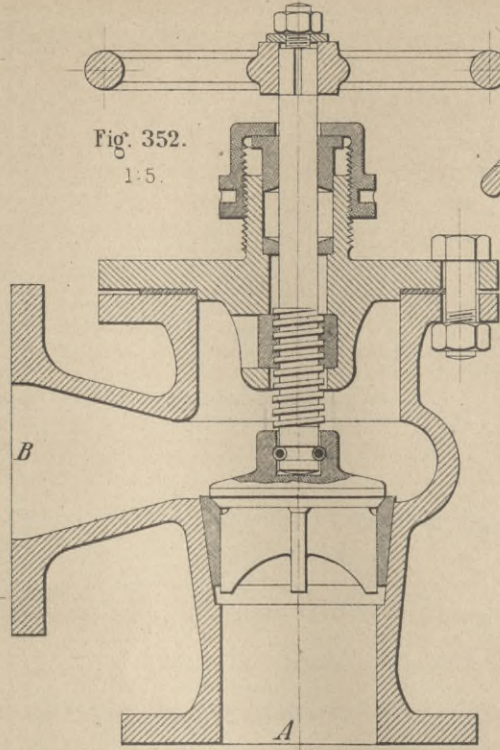


Fig. 354.

1:4.

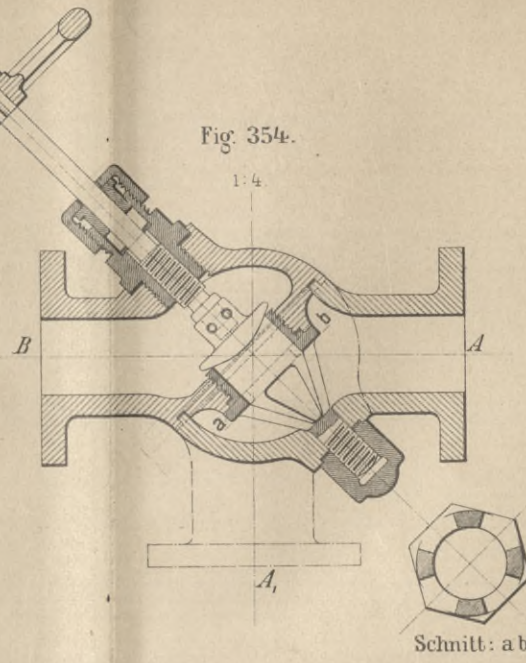


Fig. 356.

1:4.

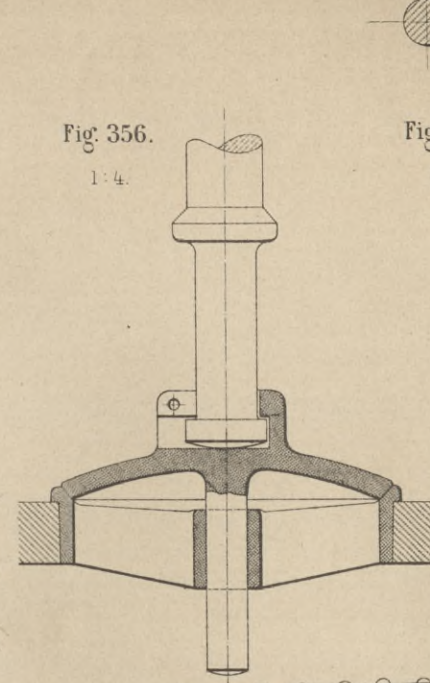
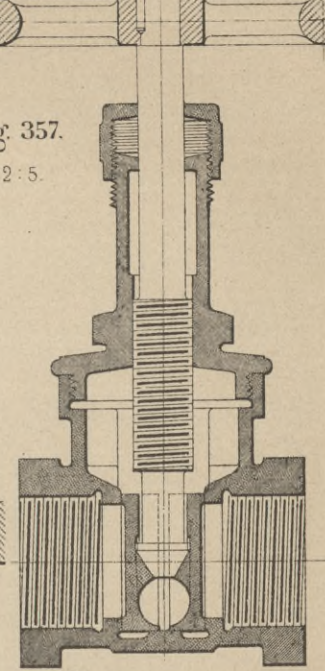


Fig. 357.

2:5.



Schnitt: a b.

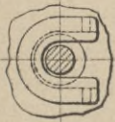
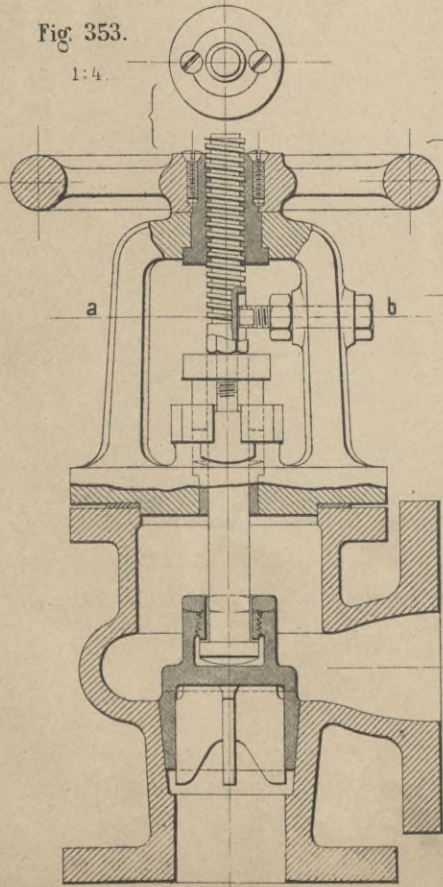


Fig. 353.

1:4.



Schnitt: a b.

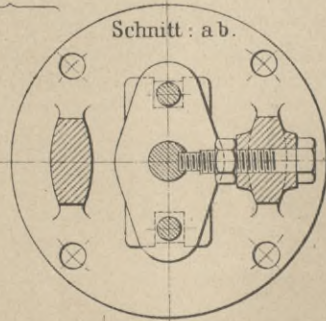


Fig. 355.

1:2.

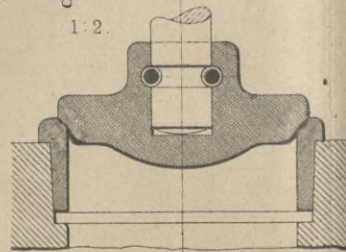


Fig. 347.

1:25.

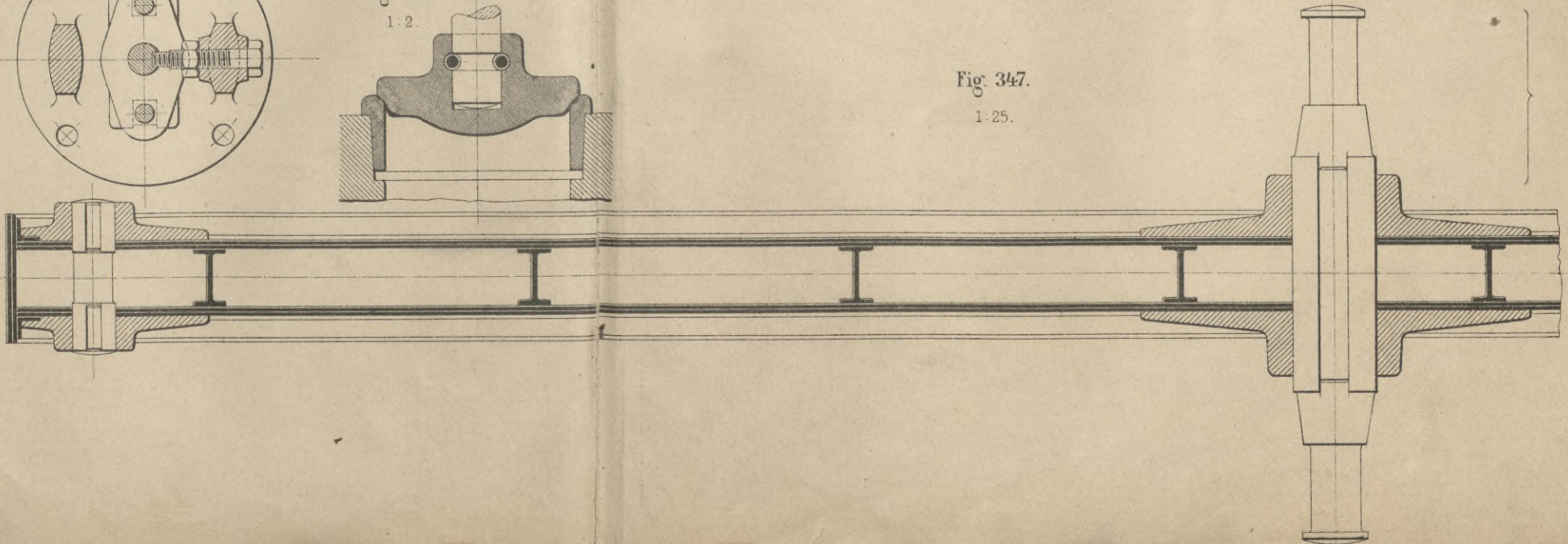
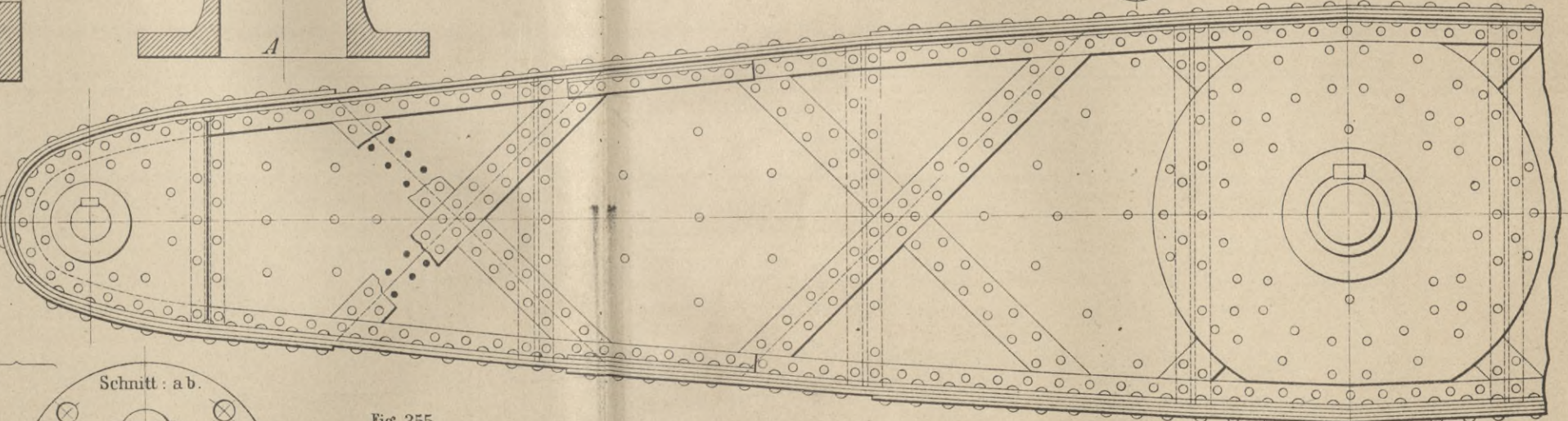




Fig. 359.

1:2.

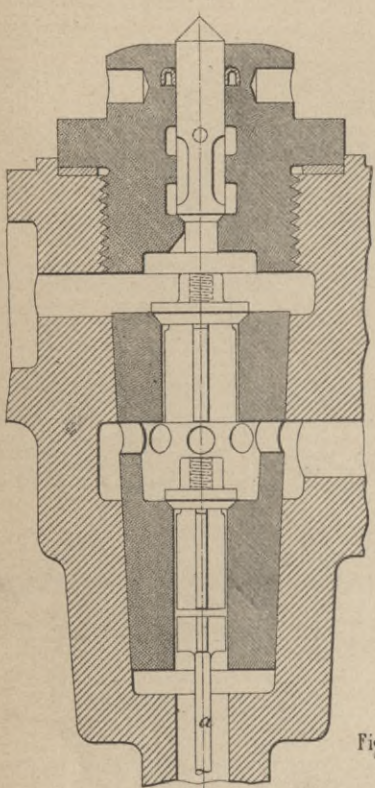
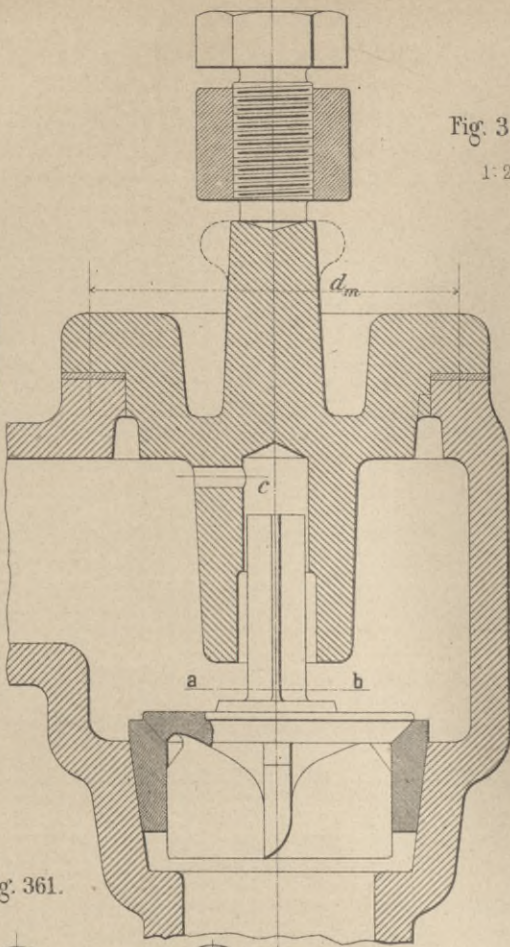


Fig. 358.

1:2.



Schnitt: a b.

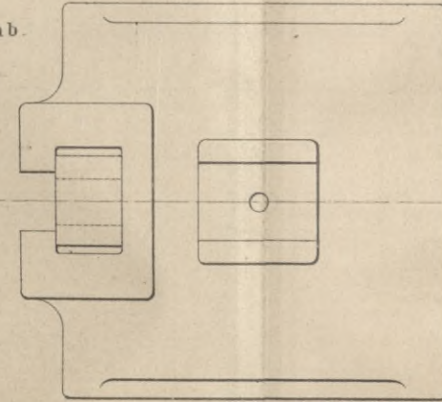


Fig. 362.

1:5.

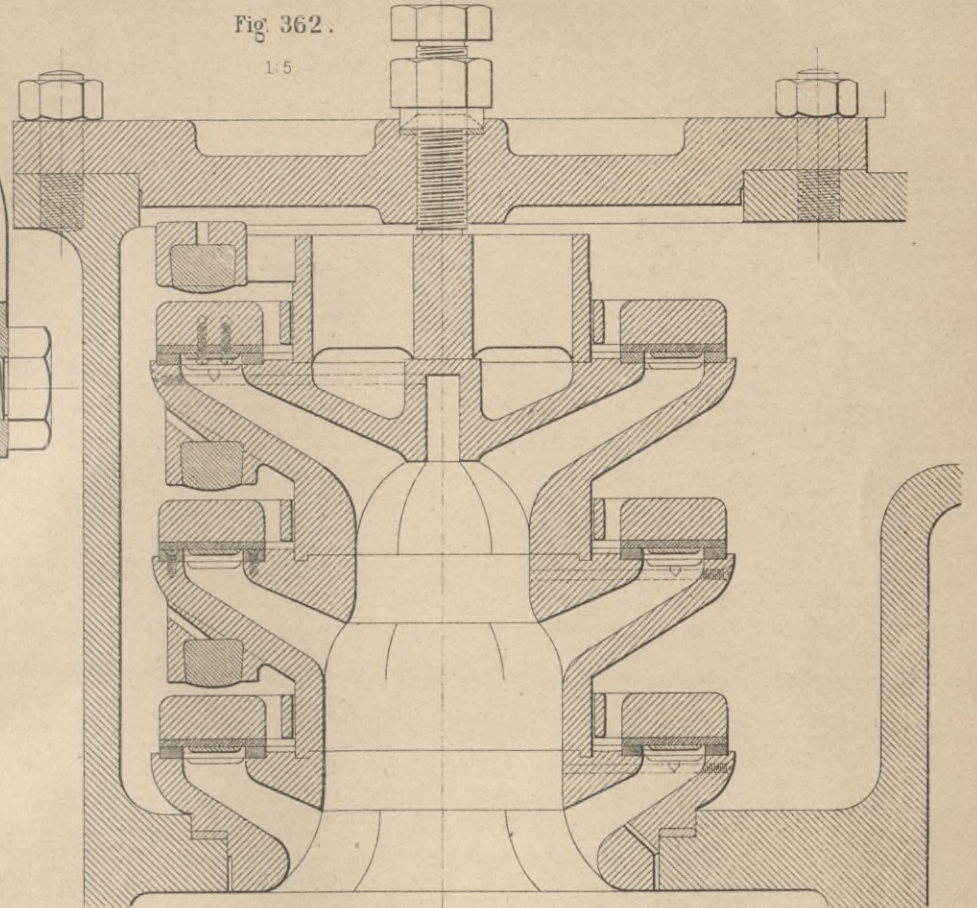


Fig. 361.

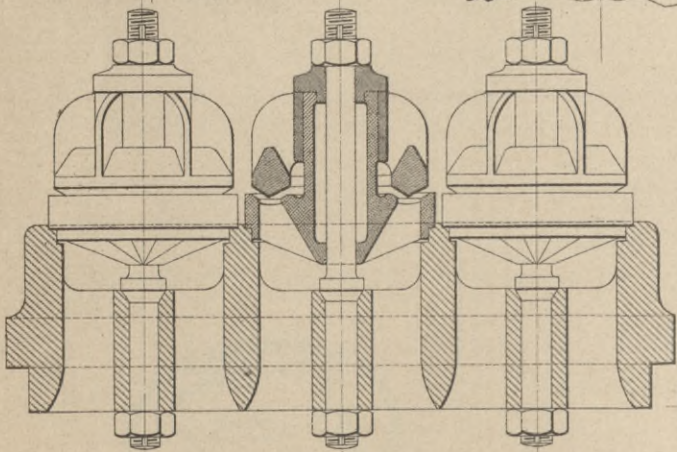


Fig. 349.

2:5.

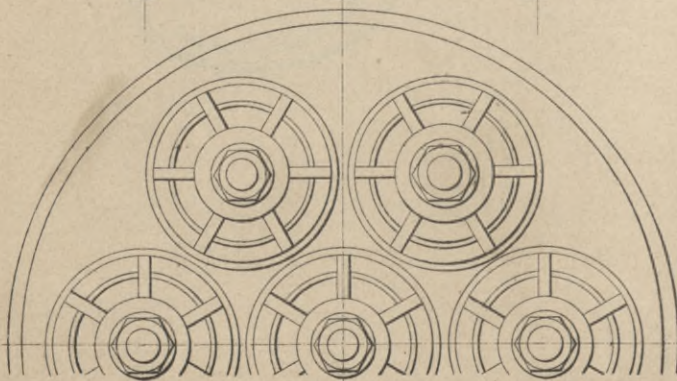
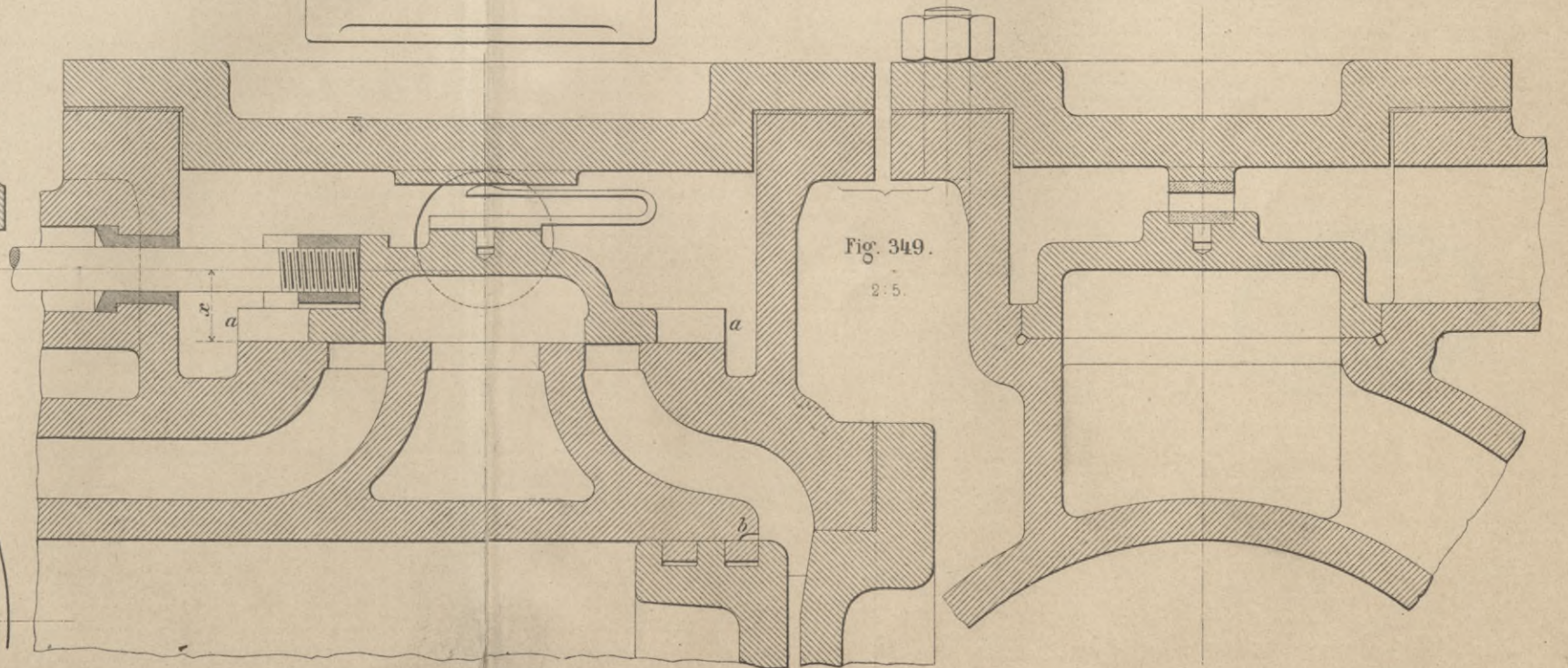




Fig. 360.

1:2

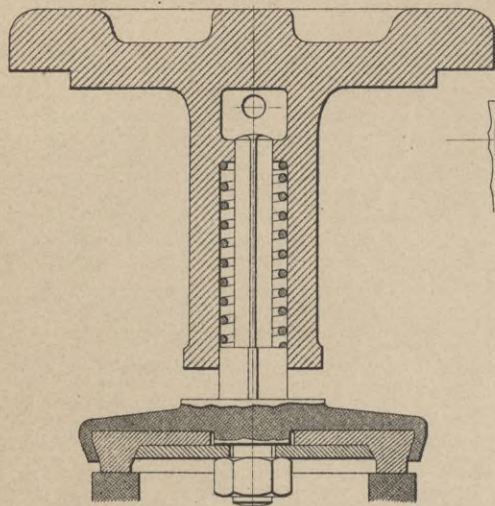
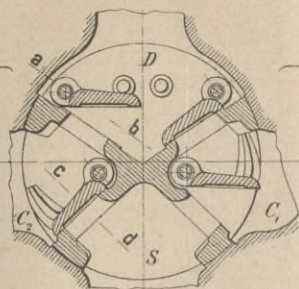


Fig. 364.

1:5



Schnitt: a b.

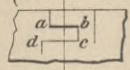
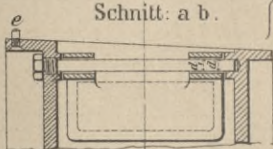
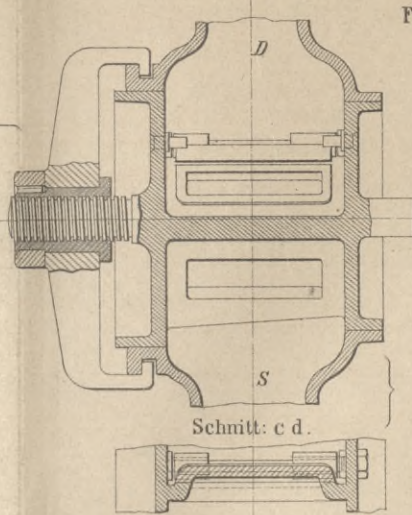


Fig. 366.

1:2



Schnitt: c d.

Fig. 365.

1:5

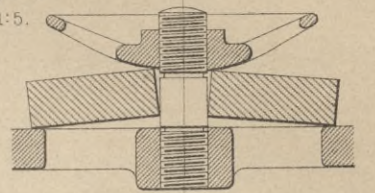


Fig. 367.

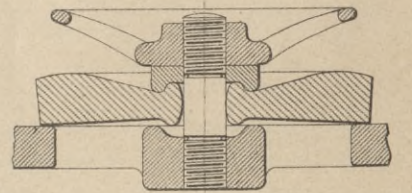


Fig. 368.

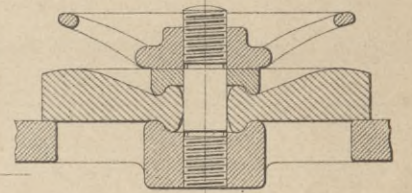


Fig. 369.

2:5

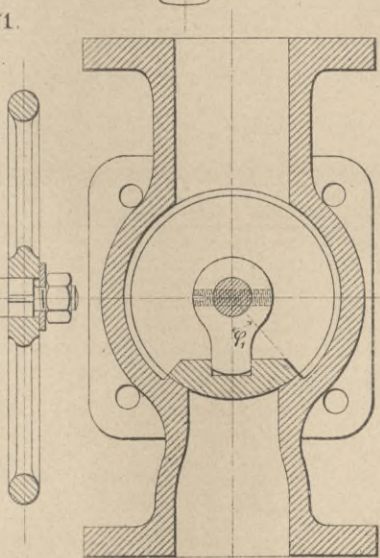


Fig. 371.

1:5

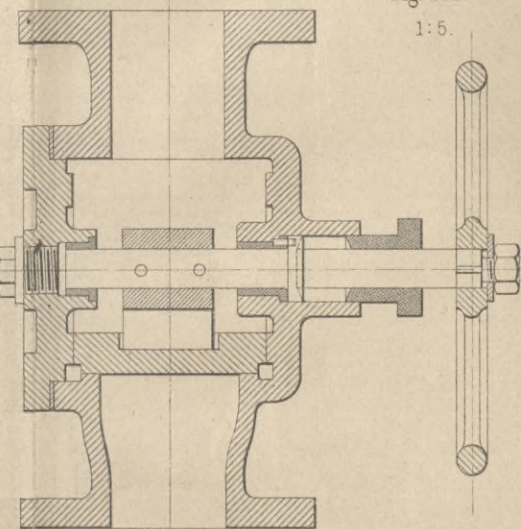


Fig. 375.

1:5

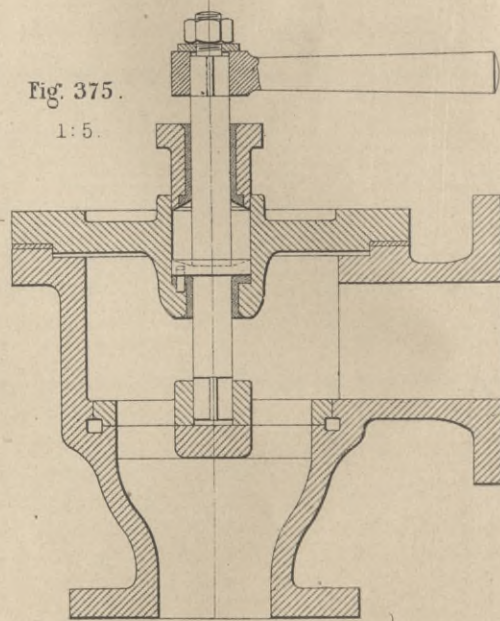


Fig. 363.

1:5

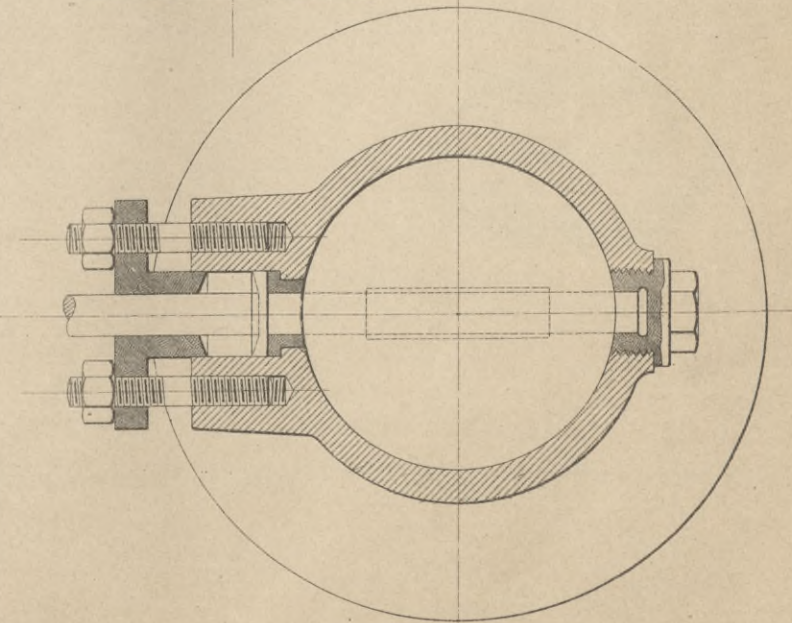
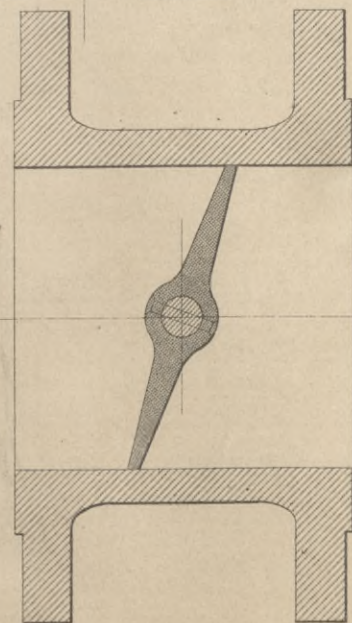
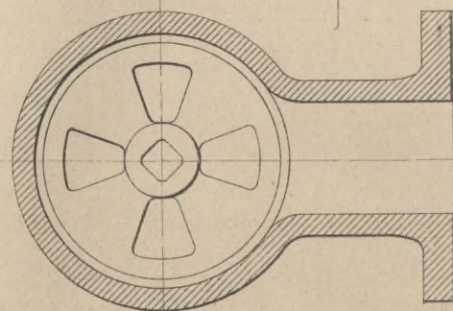
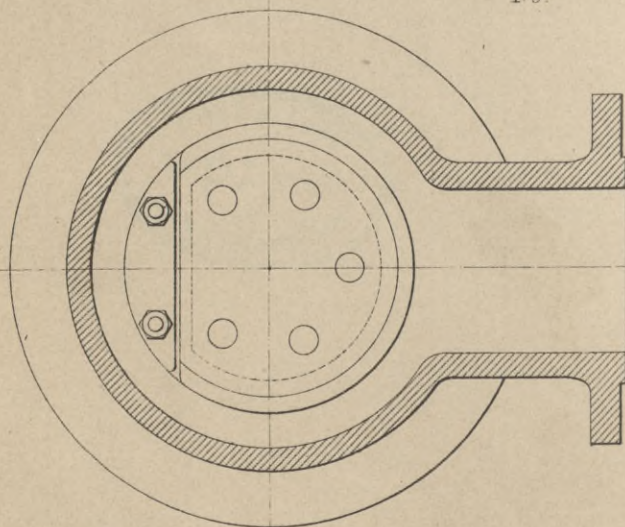




Fig. 370.
1:5.

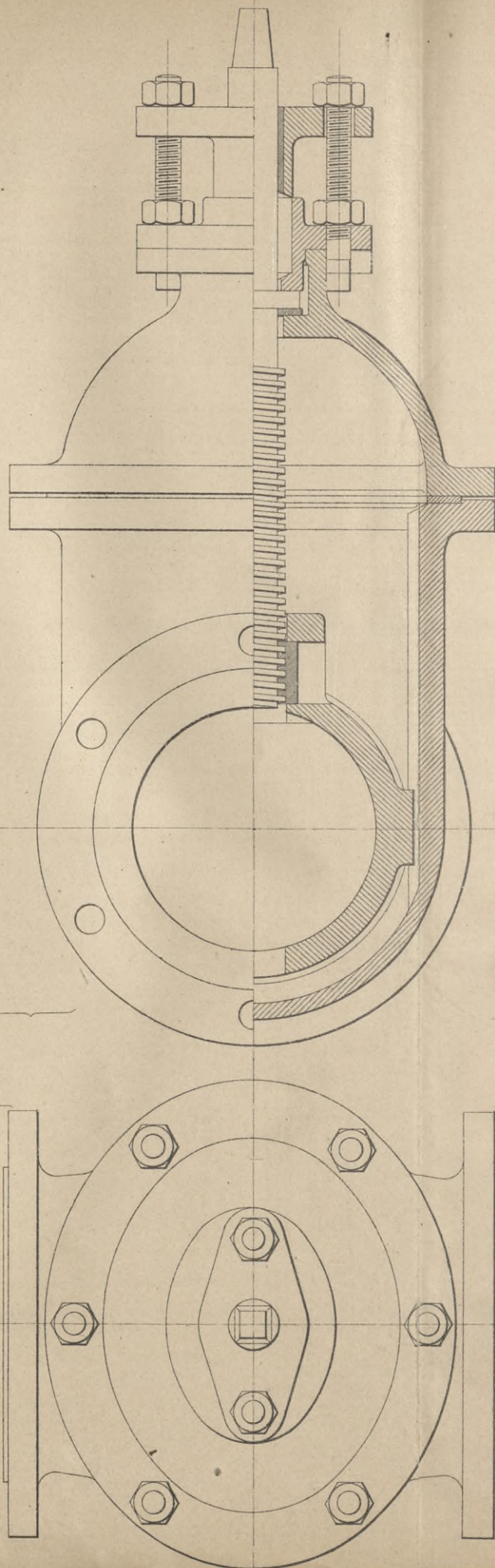
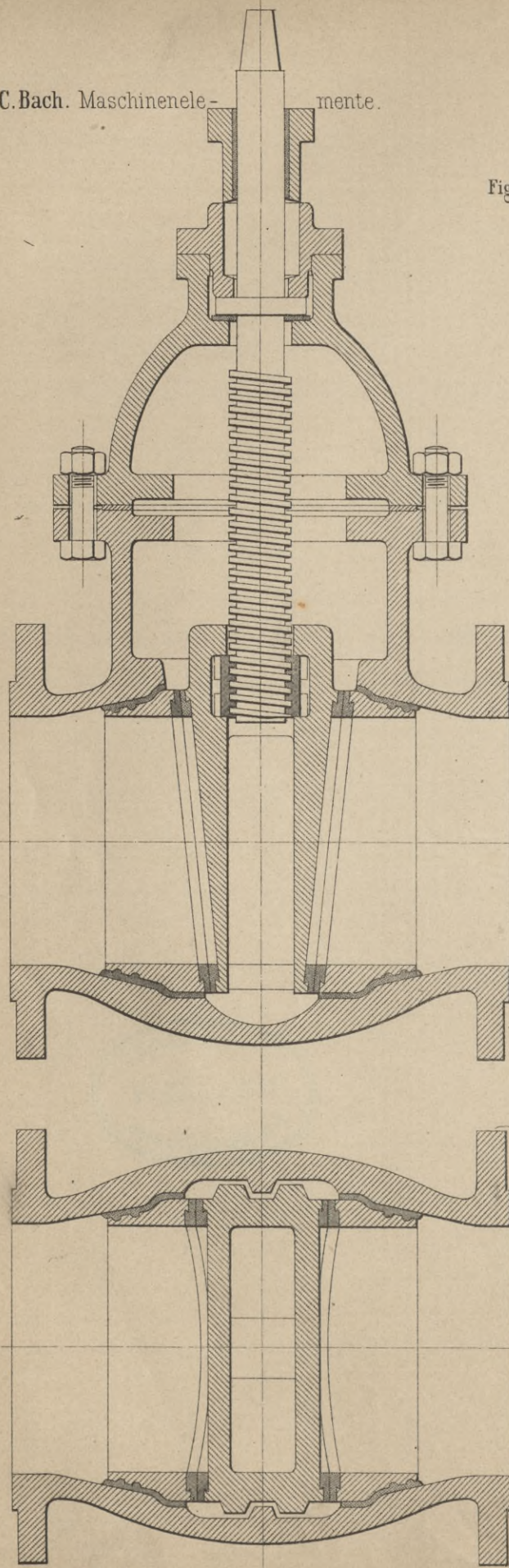
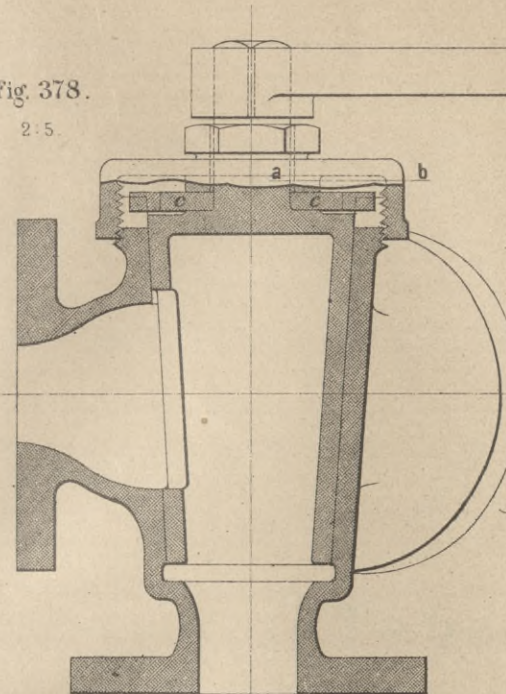


Fig. 378.
2:5.



Schnitt: a b.

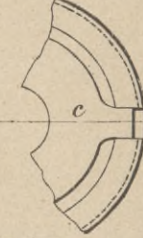


Fig. 376.
2:5.

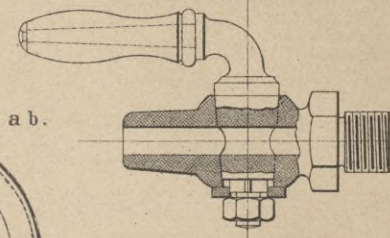


Fig. 377.
1:5.

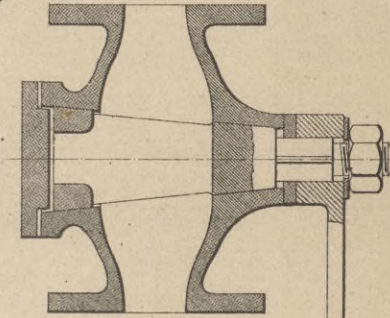


Fig. 374.
1:5.

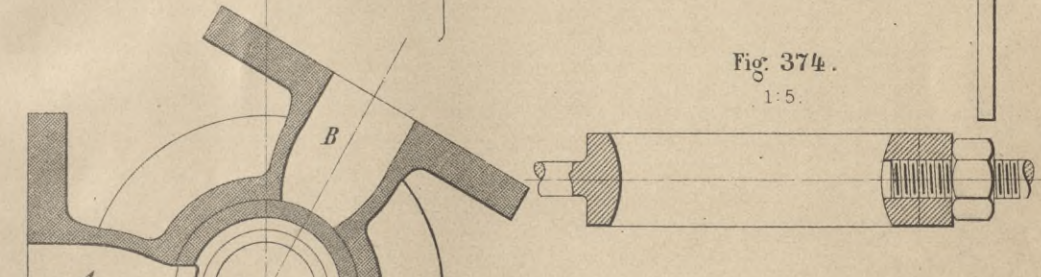


Fig. 373.
2:5.

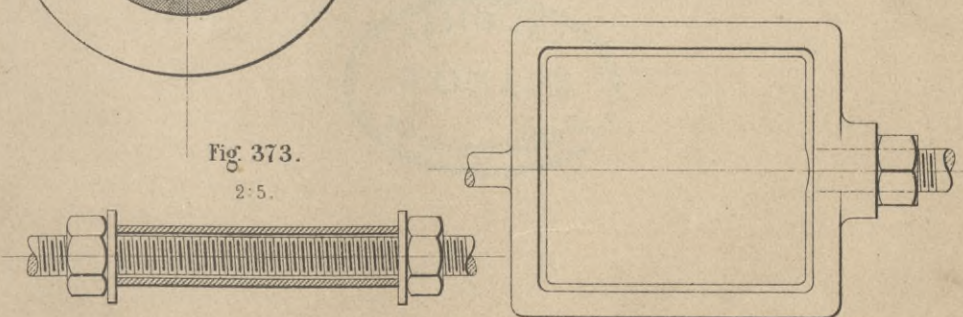
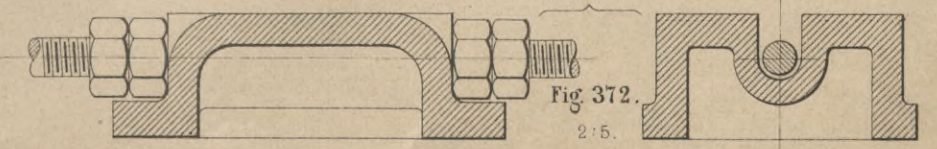


Fig. 372.
2:5.





Tabellen.

I. Tabelle der Potenzen, Wurzeln, Kreisumfänge, Kreisinnhalte, der natürlichen und der Brigg'schen Logarithmen	Seite 3
II. Trigonometrische Tabellen	26

T a b e l l e n.

I. Tabelle der Potenzen, Wurzeln, Kreisumfänge, Kreisinhalte, der natürlichen und der Brigg'schen Logarithmen.

n	n^2	n^3	\sqrt{n}	$\sqrt[3]{n}$	πn	$\frac{\pi}{4} n^2$	$\ln n$	$\lg n$
1	1	1	1,0000	1,0000	3,1416	0,7854	0,0000	0,00000
2	4	8	1,4142	1,2599	6,2832	3,1416	0,6931	0,30103
3	9	27	1,7321	1,4422	9,4248	7,0686	1,0986	0,47712
4	16	64	2,0000	1,5874	12,566	12,5664	1,3863	0,60206
5	25	125	2,2361	1,7100	15,708	19,6350	1,6094	0,69897
6	36	216	2,4495	1,8171	18,850	28,2743	1,7918	0,77815
7	49	343	2,6458	1,9129	21,991	38,4845	1,9459	0,84510
8	64	512	2,8284	2,0000	25,133	50,2655	2,0794	0,90309
9	81	729	3,0000	2,0801	28,274	63,6173	2,1972	0,95424
10	100	1 000	3,1623	2,1544	31,416	78,5398	2,3026	1,00000
11	121	1 331	3,3166	2,2240	34,558	95,0332	2,3979	1,04139
12	144	1 728	3,4641	2,2894	37,699	113,097	2,4849	1,07918
13	169	2 197	3,6056	2,3513	40,841	132,732	2,5649	1,11394
14	196	2 744	3,7417	2,4101	43,982	153,938	2,6391	1,14613
15	225	3 375	3,8730	2,4662	47,124	176,715	2,7081	1,17609
16	256	4 096	4,0000	2,5198	50,265	201,062	2,7726	1,20412
17	289	4 913	4,1231	2,5713	53,407	226,980	2,8332	1,23045
18	324	5 832	4,2426	2,6207	56,549	254,469	2,8904	1,25527
19	361	6 859	4,3589	2,6684	59,690	283,529	2,9444	1,27875

n	n^2	n^3	\sqrt{n}	$\sqrt[3]{n}$	πn	$\frac{\pi}{4} n^2$	$\ln n$	$\lg n$
20	400	8 000	4,4721	2,7144	62,832	314,159	2,9957	1,30103
21	441	9 261	4,5826	2,7589	65,973	346,361	3,0445	1,32222
22	484	10 648	4,6904	2,8020	69,115	380,133	3,0910	1,34242
23	529	12 167	4,7958	2,8439	72,257	415,476	3,1355	1,36173
24	576	13 824	4,8990	2,8845	75,398	452,389	3,1781	1,38021
25	625	15 625	5,0000	2,9240	78,540	490,874	3,2189	1,39794
26	676	17 576	5,0990	2,9625	81,681	530,929	3,2581	1,41497
27	729	19 683	5,1962	3,0000	84,823	572,555	3,2958	1,43136
28	784	21 952	5,2915	3,0366	87,965	615,752	3,3322	1,44716
29	841	24 389	5,3852	3,0723	91,106	660,520	3,3673	1,46240
30	900	27 000	5,4772	3,1072	94,248	706,858	3,4012	1,47712
31	961	29 791	5,5678	3,1414	97,389	754,768	3,4340	1,49136
32	1 024	32 768	5,6569	3,1748	100,53	804,248	3,4657	1,50515
33	1 089	35 937	5,7446	3,2075	103,67	855,299	3,4965	1,51851
34	1 156	39 304	5,8310	3,2396	106,81	907,920	3,5264	1,53148
35	1 225	42 875	5,9161	3,2711	109,96	962,113	3,5553	1,54407
36	1 296	46 656	6,0000	3,3019	113,10	1017,88	3,5835	1,55630
37	1 369	50 653	6,0828	3,3322	116,24	1075,21	3,6109	1,56820
38	1 444	54 872	6,1644	3,3620	119,38	1134,11	3,6376	1,57978
39	1 521	59 319	6,2450	3,3912	122,52	1194,59	3,6636	1,59106
40	1 600	64 000	6,3246	3,4200	125,66	1256,64	3,6889	1,60206
41	1 681	68 921	6,4031	3,4482	128,81	1320,25	3,7136	1,61278
42	1 764	74 088	6,4807	3,4760	131,95	1385,44	3,7377	1,62325
43	1 849	79 507	6,5574	3,5034	135,09	1452,20	3,7612	1,63347
44	1 936	85 184	6,6332	3,5303	138,23	1520,53	3,7842	1,64345
45	2 025	91 125	6,7082	3,5569	141,37	1590,43	3,8067	1,65321
46	2 116	97 336	6,7823	3,5830	144,51	1661,90	3,8286	1,66276
47	2 209	103 823	6,8557	3,6088	147,65	1734,94	3,8501	1,67210
48	2 304	110 592	6,9282	3,6342	150,80	1809,56	3,8712	1,68124
49	2 401	117 649	7,0000	3,6593	153,94	1885,74	3,8918	1,69020
50	2 500	125 000	7,0711	3,6840	157,08	1963,50	3,9120	1,69897
51	2 601	132 651	7,1414	3,7084	160,22	2042,82	3,9318	1,70757
52	2 704	140 608	7,2111	3,7325	163,36	2123,72	3,9512	1,71600
53	2 809	148 877	7,2801	3,7563	166,50	2206,18	3,9703	1,72428
54	2 916	157 464	7,3485	3,7798	169,65	2290,22	3,9890	1,73239
55	3 025	166 375	7,4162	3,8030	172,79	2375,83	4,0073	1,74036
56	3 136	175 616	7,4833	3,8259	175,93	2463,01	4,0254	1,74819
57	3 249	185 193	7,5498	3,8485	179,07	2551,76	4,0431	1,75587
58	3 364	195 112	7,6158	3,8709	182,21	2642,08	4,0604	1,76343
59	3 481	205 379	7,6811	3,8930	185,35	2733,97	4,0775	1,77085
60	3 600	216 000	7,7460	3,9149	188,50	2827,43	4,0943	1,77815
61	3 721	226 981	7,8102	3,9365	191,64	2922,47	4,1109	1,78533
62	3 844	238 328	7,8740	3,9579	194,78	3019,07	4,1271	1,79239
63	3 969	250 047	7,9373	3,9791	197,92	3117,25	4,1431	1,79934
64	4 096	262 144	8,0000	4,0000	201,06	3216,99	4,1589	1,80618

n	n^2	n^3	\sqrt{n}	$\sqrt[3]{n}$	πn	$\frac{\pi}{4} n^2$	$\ln n$	$\lg n$
65	4 225	274 625	8,0623	4,0207	204,20	3318,31	4,1744	1,81291
66	4 356	287 496	8,1240	4,0412	207,35	3421,19	4,1897	1,81954
67	4 489	300 763	8,1854	4,0615	210,49	3525,65	4,2047	1,82607
68	4 624	314 432	8,2462	4,0817	213,63	3631,68	4,2195	1,83251
69	4 761	328 509	8,3066	4,1016	216,77	3739,28	4,2341	1,83885
70	4 900	343 000	8,3666	4,1213	219,91	3848,45	4,2485	1,84510
71	5 041	357 911	8,4261	4,1408	223,05	3959,19	4,2627	1,85126
72	5 184	373 248	8,4853	4,1602	226,19	4071,50	4,2767	1,85733
73	5 329	389 017	8,5440	4,1793	229,34	4185,39	4,2905	1,86332
74	5 476	405 224	8,6023	4,1983	232,48	4300,84	4,3041	1,86923
75	5 625	421 875	8,6603	4,2172	235,62	4417,86	4,3175	1,87506
76	5 776	438 976	8,7178	4,2358	238,76	4536,46	4,3307	1,88081
77	5 929	456 533	8,7750	4,2543	241,90	4656,63	4,3438	1,88649
78	6 084	474 552	8,8318	4,2727	245,04	4778,36	4,3567	1,89209
79	6 241	493 039	8,8882	4,2908	248,19	4901,67	4,3694	1,89763
80	6 400	512 000	8,9443	4,3089	251,33	5026,55	4,3820	1,90309
81	6 561	531 441	9,0000	4,3267	254,47	5153,00	4,3944	1,90849
82	6 724	551 368	9,0554	4,3445	257,61	5281,02	4,4067	1,91381
83	6 889	571 787	9,1104	4,3621	260,75	5410,61	4,4188	1,91908
84	7 056	592 704	9,1652	4,3795	263,89	5541,77	4,4308	1,92428
85	7 225	614 125	9,2195	4,3968	267,04	5674,50	4,4427	1,92942
86	7 396	636 056	9,2736	4,4140	270,18	5808,80	4,4543	1,93450
87	7 569	658 503	9,3274	4,4310	273,32	5944,68	4,4659	1,93952
88	7 744	681 472	9,3808	4,4480	276,46	6082,12	4,4773	1,94448
89	7 921	704 969	9,4340	4,4647	279,60	6221,14	4,4886	1,94939
90	8 100	729 000	9,4868	4,4814	282,74	6361,73	4,4998	1,95424
91	8 281	753 571	9,5394	4,4979	285,88	6503,88	4,5109	1,95904
92	8 464	778 688	9,5917	4,5144	289,03	6647,61	4,5218	1,96379
93	8 649	804 357	9,6437	4,5307	292,17	6792,91	4,5326	1,96848
94	8 836	830 584	9,6954	4,5468	295,31	6939,78	4,5433	1,97313
95	9 025	857 375	9,7468	4,5629	298,45	7088,22	4,5539	1,97772
96	9 216	884 736	9,7980	4,5789	301,59	7238,23	4,5643	1,98227
97	9 409	912 673	9,8489	4,5947	304,73	7389,81	4,5747	1,98677
98	9 604	941 192	9,8995	4,6104	307,88	7542,96	4,5850	1,99123
99	9 801	970 299	9,9499	4,6261	311,02	7697,69	4,5951	1,99564
100	10 000	1 000 000	10,0000	4,6416	314,16	7853,98	4,6052	2,00000
101	10 201	1 030 301	10,0499	4,6570	317,30	8011,85	4,6151	2,00432
102	10 404	1 061 208	10,0995	4,6723	320,44	8171,28	4,6250	2,00860
103	10 609	1 092 727	10,1489	4,6875	323,58	8332,29	4,6347	2,01284
104	10 816	1 124 864	10,1980	4,7027	326,73	8494,87	4,6444	2,01703
105	11 025	1 157 625	10,2470	4,7177	329,87	8659,01	4,6540	2,02119
106	11 236	1 191 016	10,2956	4,7326	333,01	8824,73	4,6634	2,02531
107	11 449	1 225 043	10,3441	4,7475	336,15	8992,02	4,6728	2,02938
108	11 664	1 259 712	10,3923	4,7622	339,29	9160,88	4,6821	2,03342
109	11 881	1 295 029	10,4403	4,7769	342,43	9331,32	4,6913	2,03743

n	n^2	n^3	\sqrt{n}	$\sqrt[3]{n}$	πn	$\frac{\pi}{4} n^2$	$\ln n$	$\lg n$
110	12 100	1 331 000	10,4881	4,7914	345,58	9503,32	4,7005	2,04139
111	12 321	1 367 631	10,5357	4,8059	348,72	9676,89	4,7095	2,04532
112	12 544	1 404 928	10,5830	4,8203	351,86	9852,03	4,7185	2,04922
113	12 769	1 442 897	10,6301	4,8346	355,00	10028,7	4,7274	2,05308
114	12 996	1 481 544	10,6771	4,8488	358,14	10207,0	4,7362	2,05690
115	13 225	1 520 875	10,7238	4,8629	361,28	10386,9	4,7449	2,06070
116	13 456	1 560 896	10,7703	4,8770	364,42	10568,3	4,7536	2,06446
117	13 689	1 601 613	10,8167	4,8910	367,57	10751,3	4,7622	2,06819
118	13 924	1 643 032	10,8628	4,9049	370,71	10935,9	4,7707	2,07188
119	14 161	1 685 159	10,9087	4,9187	373,85	11122,0	4,7791	2,07555
120	14 400	1 728 000	10,9545	4,9324	376,99	11309,7	4,7875	2,07918
121	14 641	1 771 561	11,0000	4,9461	380,13	11499,0	4,7958	2,08279
122	14 884	1 815 848	11,0454	4,9597	383,27	11689,9	4,8040	2,08636
123	15 129	1 860 867	11,0905	4,9732	386,42	11882,3	4,8122	2,08991
124	15 376	1 906 624	11,1355	4,9866	389,56	12076,3	4,8203	2,09342
125	15 625	1 953 125	11,1803	5,0000	392,70	12271,8	4,8283	2,09691
126	15 876	2 000 376	11,2250	5,0133	395,84	12469,0	4,8363	2,10037
127	16 129	2 048 383	11,2694	5,0265	398,98	12667,7	4,8442	2,10380
128	16 384	2 097 152	11,3137	5,0397	402,12	12868,0	4,8520	2,10721
129	16 641	2 146 689	11,3578	5,0528	405,27	13069,8	4,8598	2,11059
130	16 900	2 197 000	11,4018	5,0658	408,41	13273,2	4,8675	2,11394
131	17 161	2 248 091	11,4455	5,0788	411,55	13478,2	4,8752	2,11727
132	17 424	2 299 968	11,4891	5,0916	414,69	13684,8	4,8828	2,12057
133	17 689	2 352 637	11,5326	5,1045	417,83	13892,9	4,8903	2,12385
134	17 956	2 406 104	11,5758	5,1172	420,97	14102,6	4,8978	2,12710
135	18 225	2 460 375	11,6190	5,1299	424,12	14313,9	4,9053	2,13033
136	18 496	2 515 456	11,6619	5,1426	427,26	14526,7	4,9127	2,13354
137	18 769	2 571 353	11,7047	5,1551	430,40	14741,1	4,9200	2,13672
138	19 044	2 628 072	11,7473	5,1676	433,54	14957,1	4,9273	2,13988
139	19 321	2 685 619	11,7898	5,1801	436,68	15174,7	4,9345	2,14301
140	19 600	2 744 000	11,8322	5,1925	439,82	15393,8	4,9416	2,14613
141	19 881	2 803 221	11,8743	5,2048	442,96	15614,5	4,9488	2,14922
142	20 164	2 863 288	11,9164	5,2171	446,11	15836,8	4,9558	2,15229
143	20 449	2 924 207	11,9583	5,2293	449,25	16060,6	4,9628	2,15534
144	20 736	2 985 984	12,0000	5,2415	452,39	16286,0	4,9698	2,15836
145	21 025	3 048 625	12,0416	5,2536	455,53	16513,0	4,9767	2,16137
146	21 316	3 112 136	12,0830	5,2656	458,67	16741,5	4,9836	2,16435
147	21 609	3 176 523	12,1244	5,2776	461,81	16971,7	4,9904	2,16732
148	21 904	3 241 792	12,1655	5,2896	464,96	17203,4	4,9972	2,17026
149	22 201	3 307 949	12,2066	5,3015	468,10	17436,6	5,0039	2,17319
150	22 500	3 375 000	12,2474	5,3133	471,24	17671,5	5,0106	2,17609
151	22 801	3 442 951	12,2882	5,3251	474,38	17907,9	5,0173	2,17898
152	23 104	3 511 808	12,3288	5,3368	477,52	18145,8	5,0239	2,18184
153	23 409	3 581 577	12,3693	5,3485	480,66	18385,4	5,0304	2,18469
154	23 716	3 652 264	12,4097	5,3601	483,81	18626,5	5,0370	2,18752

n	n^2	n^3	\sqrt{n}	$\sqrt[3]{n}$	πn	$\frac{\pi}{4} n^2$	$\ln n$	$\lg n$
155	24 025	3 723 875	12,4499	5,3717	486,95	18869,2	5,0434	2,19033
156	24 336	3 796 416	12,4900	5,3832	490,09	19113,4	5,0499	2,19312
157	24 649	3 869 893	12,5300	5,3947	493,23	19359,3	5,0562	2,19590
158	24 964	3 944 312	12,5698	5,4061	496,37	19606,7	5,0626	2,19866
159	25 281	4 019 679	12,6095	5,4175	499,51	19855,7	5,0689	2,20140
160	25 600	4 096 000	12,6491	5,4288	502,65	20106,2	5,0752	2,20412
161	25 921	4 173 281	12,6886	5,4401	505,80	20358,3	5,0814	2,20683
162	26 244	4 251 528	12,7279	5,4514	508,94	20612,0	5,0876	2,20952
163	26 569	4 330 747	12,7671	5,4626	512,08	20867,2	5,0938	2,21219
164	26 896	4 410 944	12,8062	5,4737	515,22	21124,1	5,0999	2,21484
165	27 225	4 492 125	12,8452	5,4848	518,36	21382,5	5,1059	2,21748
166	27 556	4 574 296	12,8841	5,4959	521,50	21642,4	5,1120	2,22011
167	27 889	4 657 463	12,9228	5,5069	524,65	21904,0	5,1180	2,22272
168	28 224	4 741 632	12,9615	5,5178	527,79	22167,1	5,1240	2,22531
169	28 561	4 826 809	13,0000	5,5288	530,93	22431,8	5,1299	2,22789
170	28 900	4 913 000	13,0384	5,5397	534,07	22698,0	5,1358	2,23045
171	29 241	5 000 211	13,0767	5,5505	537,21	22965,8	5,1417	2,23300
172	29 584	5 088 448	13,1149	5,5613	540,35	23235,2	5,1475	2,23553
173	29 929	5 177 717	13,1529	5,5721	543,50	23506,2	5,1533	2,23805
174	30 276	5 268 024	13,1909	5,5828	546,64	23778,7	5,1591	2,24055
175	30 625	5 359 375	13,2288	5,5934	549,78	24052,8	5,1648	2,24304
176	30 976	5 451 776	13,2665	5,6041	552,92	24328,5	5,1705	2,24551
177	31 329	5 545 233	13,3041	5,6147	556,06	24605,7	5,1761	2,24797
178	31 684	5 639 752	13,3417	5,6252	559,20	24884,6	5,1818	2,25042
179	32 041	5 735 339	13,3791	5,6357	562,35	25164,9	5,1874	2,25285
180	32 400	5 832 000	13,4164	5,6462	565,49	25446,9	5,1930	2,25527
181	32 761	5 929 741	13,4536	5,6567	568,63	25730,4	5,1985	2,25768
182	33 124	6 028 568	13,4907	5,6671	571,77	26015,5	5,2040	2,26007
183	33 489	6 128 487	13,5277	5,6774	574,91	26302,2	5,2095	2,26245
184	33 856	6 229 504	13,5647	5,6877	578,05	26590,4	5,2149	2,26482
185	34 225	6 331 625	13,6015	5,6980	581,19	26880,3	5,2204	2,26717
186	34 596	6 434 856	13,6382	5,7083	584,34	27171,6	5,2257	2,26951
187	34 969	6 539 203	13,6748	5,7185	587,48	27464,6	5,2311	2,27184
188	35 344	6 644 672	13,7113	5,7287	590,62	27759,1	5,2364	2,27416
189	35 721	6 751 269	13,7477	5,7388	593,76	28055,2	5,2417	2,27646
190	36 100	6 859 000	13,7840	5,7489	596,90	28352,9	5,2470	2,27875
191	36 481	6 967 871	13,8203	5,7590	600,04	28652,1	5,2523	2,28103
192	36 864	7 077 888	13,8564	5,7690	603,19	28952,9	5,2575	2,28330
193	37 249	7 189 057	13,8924	5,7790	606,33	29255,3	5,2627	2,28556
194	37 636	7 301 384	13,9284	5,7890	609,47	29559,2	5,2679	2,28780
195	38 025	7 414 875	13,9642	5,7989	612,61	29864,8	5,2730	2,29003
196	38 416	7 529 536	14,0000	5,8088	615,75	30171,9	5,2781	2,29226
197	38 809	7 645 373	14,0357	5,8186	618,89	30480,5	5,2832	2,29447
198	39 204	7 762 392	14,0712	5,8285	622,04	30790,7	5,2883	2,29667
199	39 601	7 880 599	14,1067	5,8383	625,18	31102,6	5,2933	2,29885

n	n^2	n^3	\sqrt{n}	$\sqrt[3]{n}$	πn	$\frac{\pi}{4}n^2$	$\ln n$	$\lg n$
200	40 000	8 000 000	14,1421	5,8480	628,32	31415,9	5,2983	2,30103
201	40 401	8 120 601	14,1774	5,8578	631,46	31730,9	5,3033	2,30320
202	40 804	8 242 408	14,2127	5,8675	634,60	32047,4	5,3083	2,30535
203	41 209	8 365 427	14,2478	5,8771	637,74	32365,5	5,3132	2,30750
204	41 616	8 489 664	14,2829	5,8868	640,88	32685,1	5,3181	2,30963
205	42 025	8 615 125	14,3178	5,8964	644,03	33006,4	5,3230	2,31175
206	42 436	8 741 816	14,3527	5,9059	647,17	33329,2	5,3279	2,31387
207	42 849	8 869 743	14,3875	5,9155	650,31	33653,5	5,3327	2,31597
208	43 264	8 998 912	14,4222	5,9250	653,45	33979,5	5,3375	2,31806
209	43 681	9 129 329	14,4568	5,9345	656,59	34307,0	5,3423	2,32015
210	44 100	9 261 000	14,4914	5,9439	659,73	34636,1	5,3471	2,32222
211	44 521	9 393 931	14,5258	5,9533	662,88	34966,7	5,3519	2,32428
212	44 944	9 528 128	14,5602	5,9627	666,02	35298,9	5,3566	2,32634
213	45 369	9 663 597	14,5945	5,9721	669,16	35632,7	5,3613	2,32838
214	45 796	9 800 344	14,6287	5,9814	672,30	35968,1	5,3660	2,33041
215	46 225	9 938 375	14,6629	5,9907	675,44	36305,0	5,3706	2,33244
216	46 656	10 077 696	14,6969	6,0000	678,58	36643,5	5,3753	2,33445
217	47 089	10 218 313	14,7309	6,0092	681,73	36983,6	5,3799	2,33646
218	47 524	10 360 232	14,7648	6,0185	684,87	37325,3	5,3845	2,33846
219	47 961	10 503 459	14,7986	6,0277	688,01	37668,5	5,3891	2,34044
220	48 400	10 648 000	14,8324	6,0368	691,15	38013,3	5,3936	2,34242
221	48 841	10 793 861	14,8661	6,0459	694,29	38359,6	5,3982	2,34439
222	49 284	10 941 048	14,8997	6,0550	697,43	38707,6	5,4027	2,34635
223	49 729	11 089 567	14,9332	6,0641	700,58	39057,1	5,4072	2,34830
224	50 176	11 239 424	14,9666	6,0732	703,72	39408,1	5,4116	2,35025
225	50 625	11 390 625	15,0000	6,0822	706,86	39760,8	5,4161	2,35218
226	51 076	11 543 176	15,0333	6,0912	710,00	40115,0	5,4205	2,35411
227	51 529	11 697 083	15,0665	6,1002	713,14	40470,8	5,4250	2,35603
228	51 984	11 852 352	15,0997	6,1091	716,28	40828,1	5,4293	2,35793
229	52 441	12 008 989	15,1327	6,1180	719,42	41187,1	5,4337	2,35984
230	52 900	12 167 000	15,1658	6,1269	722,57	41547,6	5,4381	2,36173
231	53 361	12 326 391	15,1987	6,1358	725,71	41909,6	5,4424	2,36361
232	53 824	12 487 168	15,2315	6,1446	728,85	42273,3	5,4467	2,36549
233	54 289	12 649 337	15,2643	6,1534	731,99	42638,5	5,4510	2,36736
234	54 756	12 812 904	15,2971	6,1622	735,13	43005,3	5,4553	2,36922
235	55 225	12 977 875	15,3297	6,1710	738,27	43373,6	5,4596	2,37107
236	55 696	13 144 256	15,3623	6,1797	741,42	43743,5	5,4638	2,37291
237	56 169	13 312 053	15,3948	6,1885	744,56	44115,0	5,4681	2,37475
238	56 644	13 481 272	15,4272	6,1972	747,70	44488,1	5,4723	2,37658
239	57 121	13 651 919	15,4596	6,2058	750,84	44862,7	5,4765	2,37840
240	57 600	13 824 000	15,4919	6,2145	753,98	45238,9	5,4806	2,38021
241	58 081	13 997 521	15,5242	6,2231	757,12	45616,7	5,4848	2,38202
242	58 564	14 172 488	15,5563	6,2317	760,27	45996,1	5,4889	2,38382
243	59 049	14 348 907	15,5885	6,2403	763,41	46377,0	5,4931	2,38561
244	59 536	14 526 784	15,6205	6,2488	766,55	46759,5	5,4972	2,38739

n	n^2	n^3	\sqrt{n}	$\sqrt[3]{n}$	πn	$\frac{\pi}{4}n^2$	$\ln n$	$\lg n$
245	60 025	14 706 125	15,6525	6,2573	769,69	47143,5	5,5013	2,38917
246	60 516	14 886 936	15,6844	6,2658	772,83	47529,2	5,5053	2,39094
247	61 009	15 069 223	15,7162	6,2743	775,97	47916,4	5,5094	2,39270
248	61 504	15 252 992	15,7480	6,2828	779,11	48305,1	5,5134	2,39445
249	62 001	15 438 249	15,7797	6,2912	782,26	48695,5	5,5175	2,39620
250	62 500	15 625 000	15,8114	6,2996	785,40	49087,4	5,5215	2,39794
251	63 001	15 813 251	15,8430	6,3080	788,54	49480,9	5,5255	2,39967
252	63 504	16 003 008	15,8745	6,3164	791,68	49875,9	5,5294	2,40140
253	64 009	16 194 277	15,9060	6,3247	794,82	50272,6	5,5334	2,40312
254	64 516	16 387 064	15,9374	6,3330	797,96	50670,7	5,5373	2,40483
255	65 025	16 581 375	15,9687	6,3413	801,11	51070,5	5,5413	2,40654
256	65 536	16 777 216	16,0000	6,3496	804,25	51471,9	5,5452	2,40824
257	66 049	16 974 593	16,0312	6,3579	807,39	51874,8	5,5491	2,40993
258	66 564	17 173 512	16,0624	6,3661	810,53	52279,2	5,5530	2,41162
259	67 081	17 373 979	16,0935	6,3743	813,67	52685,3	5,5568	2,41330
260	67 600	17 576 000	16,1245	6,3825	816,81	53092,9	5,5607	2,41497
261	68 121	17 779 581	16,1555	6,3907	819,96	53502,1	5,5645	2,41664
262	68 644	17 984 728	16,1864	6,3988	823,10	53912,9	5,5683	2,41830
263	69 169	18 191 447	16,2173	6,4070	826,24	54325,2	5,5722	2,41996
264	69 696	18 399 744	16,2481	6,4151	829,38	54739,1	5,5759	2,42160
265	70 225	18 609 625	16,2788	6,4232	832,52	55154,6	5,5797	2,42325
266	70 756	18 821 096	16,3095	6,4312	835,66	55571,6	5,5835	2,42488
267	71 289	19 034 163	16,3401	6,4393	838,81	55990,2	5,5872	2,42651
268	71 824	19 248 832	16,3707	6,4473	841,95	56410,4	5,5910	2,42813
269	72 361	19 465 109	16,4012	6,4553	845,09	56832,2	5,5947	2,42975
270	72 900	19 683 000	16,4317	6,4633	848,23	57255,5	5,5984	2,43136
271	73 441	19 902 511	16,4621	6,4713	851,37	57680,4	5,6021	2,43297
272	73 984	20 123 648	16,4924	6,4792	854,51	58106,9	5,6058	2,43457
273	74 529	20 346 417	16,5227	6,4872	857,65	58534,9	5,6095	2,43616
274	75 076	20 570 824	16,5529	6,4951	860,80	58964,6	5,6131	2,43775
275	75 625	20 796 875	16,5831	6,5030	863,94	59395,7	5,6168	2,43933
276	76 176	21 024 576	16,6132	6,5108	867,08	59828,5	5,6204	2,44091
277	76 729	21 253 933	16,6433	6,5187	870,22	60262,8	5,6240	2,44248
278	77 284	21 484 952	16,6733	6,5265	873,36	60698,7	5,6276	2,44404
279	77 841	21 717 639	16,7033	6,5343	876,50	61136,2	5,6312	2,44560
280	78 400	21 952 000	16,7332	6,5421	879,65	61575,2	5,6348	2,44716
281	78 961	22 188 041	16,7631	6,5499	882,79	62015,8	5,6384	2,44871
282	79 524	22 425 768	16,7929	6,5577	885,93	62458,0	5,6419	2,45025
283	80 089	22 665 187	16,8226	6,5654	889,07	62901,8	5,6454	2,45179
284	80 656	22 906 304	16,8523	6,5731	892,21	63347,1	5,6490	2,45332
285	81 225	23 149 125	16,8819	6,5808	895,35	63794,0	5,6525	2,45484
286	81 796	23 393 656	16,9115	6,5885	898,50	64242,4	5,6560	2,45637
287	82 369	23 639 903	16,9411	6,5962	901,64	64692,5	5,6595	2,45788
288	82 944	23 887 872	16,9706	6,6039	904,78	65144,1	5,6630	2,45939
289	83 521	24 137 569	17,0000	6,6115	907,92	65597,2	5,6664	2,46090

n	n^2	n^3	\sqrt{n}	$\sqrt[3]{n}$	πn	$\frac{\pi}{4} n^2$	$\ln n$	$\lg n$
290	84 100	24 389 000	17,0294	6,6191	911,06	66052,0	5,6699	2,46240
291	84 681	24 642 171	17,0587	6,6267	914,20	66508,3	5,6733	2,46389
292	85 264	24 897 088	17,0880	6,6343	917,35	66966,2	5,6768	2,46538
293	85 849	25 153 757	17,1172	6,6419	920,49	67425,6	5,6802	2,46687
294	86 436	25 412 184	17,1464	6,6494	923,63	67886,7	5,6836	2,46835
295	87 025	25 672 375	17,1756	6,6569	926,77	68349,3	5,6870	2,46982
296	87 616	25 934 336	17,2047	6,6644	929,91	68813,4	5,6904	2,47129
297	88 209	26 198 073	17,2337	6,6719	933,05	69279,2	5,6937	2,47276
298	88 804	26 463 592	17,2627	6,6794	936,19	69746,5	5,6971	2,47422
299	89 401	26 730 899	17,2916	6,6869	939,34	70215,4	5,7004	2,47567
300	90 000	27 000 000	17,3205	6,6943	942,48	70685,8	5,7038	2,47712
301	90 601	27 270 901	17,3494	6,7018	945,62	71157,9	5,7071	2,47857
302	91 204	27 543 608	17,3781	6,7092	948,76	71631,5	5,7104	2,48001
303	91 809	27 818 127	17,4069	6,7166	951,90	72106,6	5,7137	2,48144
304	92 416	28 094 464	17,4356	6,7240	955,04	72583,4	5,7170	2,48287
305	93 025	28 372 625	17,4642	6,7313	958,19	73061,7	5,7203	2,48430
306	93 636	28 652 616	17,4929	6,7387	961,33	73541,5	5,7236	2,48572
307	94 249	28 934 443	17,5214	6,7460	964,47	74023,0	5,7268	2,48714
308	94 864	29 218 112	17,5499	6,7533	967,61	74506,0	5,7301	2,48855
309	95 481	29 503 629	17,5784	6,7606	970,75	74990,6	5,7333	2,48996
310	96 100	29 791 000	17,6068	6,7679	973,89	75476,8	5,7366	2,49136
311	96 721	30 080 231	17,6352	6,7752	977,04	75964,5	5,7398	2,49276
312	97 344	30 371 328	17,6635	6,7824	980,18	76453,8	5,7430	2,49415
313	97 969	30 664 297	17,6918	6,7897	983,32	76944,7	5,7462	2,49554
314	98 596	30 959 144	17,7200	6,7969	986,46	77437,1	5,7494	2,49693
315	99 225	31 255 875	17,7482	6,8041	989,60	77931,1	5,7526	2,49831
316	99 856	31 554 496	17,7764	6,8113	992,74	78426,7	5,7557	2,49969
317	100 489	31 855 013	17,8045	6,8185	995,88	78923,9	5,7589	2,50106
318	101 124	32 157 432	17,8326	6,8256	999,03	79422,6	5,7621	2,50243
319	101 761	32 461 759	17,8606	6,8328	1002,2	79922,9	5,7652	2,50379
320	102 400	32 768 000	17,8885	6,8399	1005,3	80424,8	5,7683	2,50515
321	103 041	33 076 161	17,9165	6,8470	1008,5	80928,2	5,7714	2,50651
322	103 684	33 386 248	17,9444	6,8541	1011,6	81433,2	5,7746	2,50786
323	104 329	33 698 267	17,9722	6,8612	1014,7	81939,8	5,7777	2,50920
324	104 976	34 012 224	18,0000	6,8683	1017,9	82448,0	5,7807	2,51055
325	105 625	34 328 125	18,0278	6,8753	1021,0	82957,7	5,7838	2,51188
326	106 276	34 645 976	18,0555	6,8824	1024,2	83469,0	5,7869	2,51322
327	106 929	34 965 783	18,0831	6,8894	1027,3	83981,8	5,7900	2,51455
328	107 584	35 287 552	18,1108	6,8964	1030,4	84496,3	5,7930	2,51587
329	108 241	35 611 289	18,1384	6,9034	1033,6	85012,3	5,7961	2,51720
330	108 900	35 937 000	18,1659	6,9104	1036,7	85529,9	5,7991	2,51851
331	109 561	36 264 691	18,1934	6,9174	1039,9	86049,0	5,8021	2,51983
332	110 224	36 594 368	18,2209	6,9244	1043,0	86569,7	5,8051	2,52114
333	110 889	36 926 037	18,2483	6,9313	1046,2	87092,0	5,8081	2,52244
334	111 556	37 259 704	18,2757	6,9382	1049,3	87615,9	5,8111	2,52375

n	n^2	n^3	\sqrt{n}	$\sqrt[3]{n}$	πn	$\frac{\pi}{4} n^2$	$\ln n$	$\lg n$
335	112 225	37 595 375	18,3030	6,9451	1052,4	88141,3	5,8141	2,52504
336	112 896	37 933 056	18,3303	6,9521	1055,6	88668,3	5,8171	2,52634
337	113 569	38 272 753	18,3576	6,9589	1058,7	89196,9	5,8201	2,52763
338	114 244	38 614 472	18,3848	6,9658	1061,9	89727,9	5,8230	2,52892
339	114 921	38 958 219	18,4120	6,9727	1065,0	90258,7	5,8260	2,53020
340	115 600	39 304 000	18,4391	6,9795	1068,1	90792,0	5,8289	2,53148
341	116 281	39 651 821	18,4662	6,9864	1071,3	91326,9	5,8319	2,53275
342	116 964	40 001 688	18,4932	6,9932	1074,4	91863,3	5,8348	2,53403
343	117 649	40 353 607	18,5203	7,0000	1077,6	92401,3	5,8377	2,53529
344	118 336	40 707 584	18,5472	7,0068	1080,7	92940,9	5,8406	2,53656
345	119 025	41 063 625	18,5742	7,0136	1083,8	93482,0	5,8435	2,53782
346	119 716	41 421 736	18,6011	7,0203	1087,0	94024,7	5,8464	2,53908
347	120 409	41 781 923	18,6279	7,0271	1090,1	94569,0	5,8493	2,54033
348	121 104	42 144 192	18,6548	7,0338	1093,3	95114,9	5,8522	2,54158
349	121 801	42 508 549	18,6815	7,0406	1096,4	95662,3	5,8551	2,54283
350	122 500	42 875 000	18,7083	7,0473	1099,6	96211,3	5,8579	2,54407
351	123 201	43 243 551	18,7350	7,0540	1102,7	96761,8	5,8608	2,54531
352	123 904	43 614 208	18,7617	7,0607	1105,8	97314,0	5,8636	2,54654
353	124 609	43 986 977	18,7883	7,0674	1109,0	97867,7	5,8665	2,54777
354	125 316	44 361 864	18,8149	7,0740	1112,1	98423,0	5,8693	2,54900
355	126 025	44 738 875	18,8414	7,0807	1115,3	98979,8	5,8721	2,55023
356	126 736	45 118 016	18,8680	7,0873	1118,4	99538,2	5,8749	2,55145
357	127 449	45 499 293	18,8944	7,0940	1121,5	100098	5,8777	2,55267
358	128 164	45 882 712	18,9209	7,1006	1124,7	100660	5,8805	2,55388
359	128 881	46 268 279	18,9473	7,1072	1127,8	101223	5,8833	2,55509
360	129 600	46 656 000	18,9737	7,1138	1131,0	101788	5,8861	2,55630
361	130 321	47 045 881	19,0000	7,1204	1134,1	102354	5,8889	2,55751
362	131 044	47 437 928	19,0263	7,1269	1137,3	102922	5,8916	2,55871
363	131 769	47 832 147	19,0526	7,1335	1140,4	103491	5,8944	2,55991
364	132 496	48 228 544	19,0788	7,1400	1143,5	104062	5,8972	2,56110
365	133 225	48 627 125	19,1050	7,1466	1146,7	104635	5,8999	2,56229
366	133 956	49 027 896	19,1311	7,1531	1149,8	105209	5,9026	2,56348
367	134 689	49 430 863	19,1572	7,1596	1153,0	105785	5,9054	2,56467
368	135 424	49 836 032	19,1833	7,1661	1156,1	106362	5,9081	2,56585
369	136 161	50 243 409	19,2094	7,1726	1159,2	106941	5,9108	2,56703
370	136 900	50 653 000	19,2354	7,1791	1162,4	107521	5,9135	2,56820
371	137 641	51 064 811	19,2614	7,1855	1165,5	108103	5,9162	2,56937
372	138 384	51 478 848	19,2873	7,1920	1168,7	108687	5,9189	2,57054
373	139 129	51 895 117	19,3132	7,1984	1171,8	109272	5,9216	2,57171
374	139 876	52 313 624	19,3391	7,2048	1175,0	109858	5,9243	2,57287
375	140 625	52 734 375	19,3649	7,2112	1178,1	110447	5,9269	2,57403
376	141 376	53 157 376	19,3907	7,2177	1181,2	111036	5,9296	2,57519
377	142 129	53 582 633	19,4165	7,2240	1184,4	111628	5,9322	2,57634
378	142 884	54 010 152	19,4422	7,2304	1187,5	112221	5,9349	2,57749
379	143 641	54 439 939	19,4679	7,2368	1190,7	112815	5,9375	2,57864

n	n^2	n^3	\sqrt{n}	$\sqrt[3]{n}$	πn	$\frac{\pi}{4} n^2$	$\ln n$	$\lg n$
380	144 400	54 872 000	19,4936	7,2432	1193,8	113411	5,9402	2,57978
381	145 161	55 306 341	19,5192	7,2495	1196,9	114009	5,9428	2,58093
382	145 924	55 742 968	19,5448	7,2558	1200,1	114608	5,9454	2,58206
383	146 689	56 181 887	19,5704	7,2622	1203,2	115209	5,9480	2,58320
384	147 456	56 623 104	19,5959	7,2685	1206,4	115812	5,9506	2,58433
385	148 225	57 066 625	19,6214	7,2748	1209,5	116416	5,9532	2,58546
386	148 996	57 512 456	19,6469	7,2811	1212,7	117021	5,9558	2,58659
387	149 769	57 960 603	19,6723	7,2874	1215,8	117628	5,9584	2,58771
388	150 544	58 411 072	19,6977	7,2936	1218,9	118237	5,9610	2,58883
389	151 321	58 863 869	19,7231	7,2999	1222,1	118847	5,9636	2,58995
390	152 100	59 319 000	19,7484	7,3061	1225,2	119459	5,9661	2,59106
391	152 881	59 776 471	19,7737	7,3124	1228,4	120072	5,9687	2,59218
392	153 664	60 236 288	19,7990	7,3186	1231,5	120687	5,9713	2,59329
393	154 449	60 698 457	19,8242	7,3248	1234,6	121304	5,9738	2,59439
394	155 236	61 162 984	19,8494	7,3310	1237,8	121922	5,9764	2,59550
395	156 025	61 629 875	19,8746	7,3372	1240,9	122542	5,9789	2,59660
396	156 816	62 099 136	19,8997	7,3434	1244,1	123163	5,9814	2,59770
397	157 609	62 570 773	19,9249	7,3496	1247,2	123786	5,9839	2,59879
398	158 404	63 044 792	19,9499	7,3558	1250,4	124410	5,9865	2,59988
399	159 201	63 521 199	19,9750	7,3619	1253,5	125036	5,9890	2,60097
400	160 000	64 000 000	20,0000	7,3681	1256,6	125664	5,9915	2,60206
401	160 801	64 481 201	20,0250	7,3742	1259,8	126293	5,9940	2,60314
402	161 604	64 964 808	20,0499	7,3803	1262,9	126923	5,9965	2,60423
403	162 409	65 450 827	20,0749	7,3864	1266,1	127556	5,9989	2,60531
404	163 216	65 939 264	20,0998	7,3925	1269,2	128190	6,0014	2,60638
405	164 025	66 430 125	20,1246	7,3986	1272,3	128825	6,0039	2,60746
406	164 836	66 923 416	20,1494	7,4047	1275,5	129462	6,0064	2,60853
407	165 649	67 419 143	20,1742	7,4108	1278,6	130100	6,0088	2,60959
408	166 464	67 917 312	20,1990	7,4169	1281,8	130741	6,0113	2,61066
409	167 281	68 417 929	20,2237	7,4229	1284,9	131382	6,0137	2,61172
410	168 100	68 921 000	20,2485	7,4290	1288,1	132025	6,0162	2,61278
411	168 921	69 426 531	20,2731	7,4350	1291,2	132670	6,0186	2,61384
412	169 744	69 934 528	20,2978	7,4410	1294,3	133317	6,0210	2,61490
413	170 569	70 444 997	20,3224	7,4470	1297,5	133965	6,0234	2,61595
414	171 396	70 957 944	20,3470	7,4530	1300,6	134614	6,0259	2,61700
415	172 225	71 473 375	20,3715	7,4590	1303,8	135265	6,0283	2,61805
416	173 056	71 991 296	20,3961	7,4650	1306,9	135918	6,0307	2,61909
417	173 889	72 511 713	20,4206	7,4710	1310,0	136572	6,0331	2,62014
418	174 724	73 034 632	20,4450	7,4770	1313,2	137228	6,0355	2,62118
419	175 561	73 560 059	20,4695	7,4829	1316,3	137885	6,0379	2,62221
420	176 400	74 088 000	20,4939	7,4889	1319,5	138544	6,0403	2,62325
421	177 241	74 618 461	20,5183	7,4948	1322,6	139205	6,0426	2,62428
422	178 084	75 151 448	20,5426	7,5007	1325,8	139867	6,0450	2,62531
423	178 929	75 686 967	20,5670	7,5067	1328,9	140531	6,0474	2,62634
424	179 776	76 225 024	20,5913	7,5126	1332,0	141196	6,0497	2,62737

n	n^2	n^3	\sqrt{n}	$\sqrt[3]{n}$	πn	$\frac{\pi}{4} n^2$	$\ln n$	$\lg n$
425	180 625	76 765 625	20,6155	7,5185	1335,2	141863	6,0521	2,62839
426	181 476	77 308 776	20,6398	7,5244	1338,3	142531	6,0544	2,62941
427	182 329	77 854 483	20,6640	7,5302	1341,5	143201	6,0568	2,63043
428	183 184	78 402 752	20,6882	7,5361	1344,6	143872	6,0591	2,63144
429	184 041	78 953 589	20,7123	7,5420	1347,7	144545	6,0615	2,63246
430	184 900	79 507 000	20,7364	7,5478	1350,9	145220	6,0638	2,63347
431	185 761	80 062 991	20,7605	7,5537	1354,0	145896	6,0661	2,63448
432	186 624	80 621 568	20,7846	7,5595	1357,2	146574	6,0684	2,63548
433	187 489	81 182 737	20,8087	7,5654	1360,3	147254	6,0707	2,63649
434	188 356	81 746 504	20,8327	7,5712	1363,5	147934	6,0730	2,63749
435	189 225	82 312 875	20,8567	7,5770	1366,6	148617	6,0753	2,63849
436	190 096	82 881 856	20,8806	7,5828	1369,7	149301	6,0776	2,63949
437	190 969	83 453 453	20,9045	7,5886	1372,9	149987	6,0799	2,64048
438	191 844	84 027 672	20,9284	7,5944	1376,0	150674	6,0822	2,64147
439	192 721	84 604 519	20,9523	7,6001	1379,2	151363	6,0845	2,64246
440	193 600	85 184 000	20,9762	7,6059	1382,3	152053	6,0868	2,64345
441	194 481	85 766 121	21,0000	7,6117	1385,4	152745	6,0890	2,64444
442	195 364	86 350 888	21,0238	7,6174	1388,6	153439	6,0913	2,64542
443	196 249	86 938 307	21,0476	7,6232	1391,7	154134	6,0936	2,64640
444	197 136	87 528 384	21,0713	7,6289	1394,9	154830	6,0958	2,64738
445	198 025	88 121 125	21,0950	7,6346	1398,0	155528	6,0981	2,64836
446	198 916	88 716 536	21,1187	7,6403	1401,2	156228	6,1003	2,64933
447	199 809	89 314 623	21,1424	7,6460	1404,3	156930	6,1026	2,65031
448	200 704	89 915 392	21,1660	7,6517	1407,4	157633	6,1048	2,65128
449	201 601	90 518 849	21,1896	7,6574	1410,6	158337	6,1070	2,65225
450	202 500	91 125 000	21,2132	7,6631	1413,7	159043	6,1092	2,65321
451	203 401	91 733 851	21,2368	7,6688	1416,9	159751	6,1115	2,65418
452	204 304	92 345 408	21,2603	7,6744	1420,0	160460	6,1137	2,65514
453	205 209	92 959 677	21,2838	7,6801	1423,1	161171	6,1159	2,65610
454	206 116	93 576 664	21,3073	7,6857	1426,3	161883	6,1181	2,65706
455	207 025	94 196 375	21,3307	7,6914	1429,4	162597	6,1203	2,65801
456	207 936	94 818 816	21,3542	7,6970	1432,6	163313	6,1225	2,65896
457	208 849	95 443 993	21,3776	7,7026	1435,7	164030	6,1247	2,65992
458	209 764	96 071 912	21,4009	7,7082	1438,8	164748	6,1269	2,66087
459	210 681	96 702 579	21,4243	7,7138	1442,0	165468	6,1291	2,66181
460	211 600	97 336 000	21,4476	7,7194	1445,1	166190	6,1312	2,66276
461	212 521	97 972 181	21,4709	7,7250	1448,3	166914	6,1334	2,66370
462	213 444	98 611 128	21,4942	7,7306	1451,4	167639	6,1356	2,66464
463	214 369	99 252 847	21,5174	7,7362	1454,6	168365	6,1377	2,66558
464	215 296	99 897 344	21,5407	7,7418	1457,7	169093	6,1399	2,66652
465	216 225	100 544 625	21,5639	7,7473	1460,8	169823	6,1420	2,66745
466	217 156	101 194 696	21,5870	7,7529	1464,0	170554	6,1442	2,66839
467	218 089	101 847 563	21,6102	7,7584	1467,1	171287	6,1463	2,66932
468	219 024	102 503 232	21,6333	7,7639	1470,3	172021	6,1485	2,67025
469	219 961	103 161 709	21,6564	7,7695	1473,4	172757	6,1506	2,67117

n	n^2	n^3	\sqrt{n}	$\sqrt[3]{n}$	πn	$\frac{\pi}{4}n^2$	$\ln n$	$\lg n$
470	220 900	103 823 000	21,6795	7,7750	1476,5	173494	6,1527	2,67210
471	221 841	104 487 111	21,7025	7,7805	1479,7	174234	6,1549	2,67302
472	222 784	105 154 048	21,7256	7,7860	1482,8	174974	6,1570	2,67394
473	223 729	105 823 817	21,7486	7,7915	1486,0	175716	6,1591	2,67486
474	224 676	106 496 424	21,7715	7,7970	1489,1	176460	6,1612	2,67578
475	225 625	107 171 875	21,7945	7,8025	1492,3	177205	6,1633	2,67669
476	226 576	107 850 176	21,8174	7,8079	1495,4	177952	6,1654	2,67761
477	227 529	108 531 333	21,8403	7,8134	1498,5	178701	6,1675	2,67852
478	228 484	109 215 352	21,8632	7,8188	1501,7	179451	6,1696	2,67943
479	229 441	109 902 239	21,8861	7,8243	1504,8	180203	6,1717	2,68034
480	230 400	110 592 000	21,9089	7,8297	1508,0	180956	6,1738	2,68124
481	231 361	111 284 641	21,9317	7,8352	1511,1	181711	6,1759	2,68215
482	232 324	111 980 168	21,9545	7,8406	1514,2	182467	6,1779	2,68305
483	233 289	112 678 587	21,9773	7,8460	1517,4	183225	6,1800	2,68395
484	234 256	113 379 904	22,0000	7,8514	1520,5	183984	6,1821	2,68485
485	235 225	114 084 125	22,0227	7,8568	1523,7	184745	6,1841	2,68574
486	236 196	114 791 256	22,0454	7,8622	1526,8	185508	6,1862	2,68664
487	237 169	115 501 303	22,0681	7,8676	1530,0	186272	6,1883	2,68753
488	238 144	116 214 272	22,0907	7,8730	1533,1	187038	6,1903	2,68842
489	239 121	116 930 169	22,1133	7,8784	1536,2	187805	6,1924	2,68931
490	240 100	117 649 000	22,1359	7,8837	1539,4	188574	6,1944	2,69020
491	241 081	118 370 771	22,1585	7,8891	1542,5	189345	6,1964	2,69108
492	242 064	119 095 488	22,1811	7,8944	1545,7	190117	6,1985	2,69197
493	243 049	119 823 157	22,2036	7,8998	1548,8	190890	6,2005	2,69285
494	244 036	120 553 784	22,2261	7,9051	1551,9	191665	6,2025	2,69373
495	245 025	121 287 375	22,2486	7,9105	1555,1	192442	6,2046	2,69461
496	246 016	122 023 936	22,2711	7,9158	1558,2	193221	6,2066	2,69548
497	247 009	122 763 473	22,2935	7,9211	1561,4	194000	6,2086	2,69636
498	248 004	123 505 992	22,3159	7,9264	1564,5	194782	6,2106	2,69723
499	249 001	124 251 499	22,3383	7,9317	1567,7	195565	6,2126	2,69810
500	250 000	125 000 000	22,3607	7,9370	1570,8	196350	6,2146	2,69897
501	251 001	125 751 501	22,3830	7,9423	1573,9	197136	6,2166	2,69984
502	252 004	126 506 008	22,4054	7,9476	1577,1	197923	6,2186	2,70070
503	253 009	127 263 527	22,4277	7,9528	1580,2	198713	6,2206	2,70157
504	254 016	128 024 064	22,4499	7,9581	1583,4	199504	6,2226	2,70243
505	255 025	128 787 625	22,4722	7,9634	1586,5	200296	6,2246	2,70329
506	256 036	129 554 216	22,4944	7,9686	1589,6	201090	6,2265	2,70415
507	257 049	130 323 843	22,5167	7,9739	1592,8	201886	6,2285	2,70501
508	258 064	131 096 512	22,5389	7,9791	1595,9	202683	6,2305	2,70586
509	259 081	131 872 229	22,5610	7,9843	1599,1	203482	6,2324	2,70672
510	260 100	132 651 000	22,5832	7,9896	1602,2	204282	6,2344	2,70757
511	261 121	133 432 831	22,6053	7,9948	1605,4	205084	6,2364	2,70842
512	262 144	134 217 728	22,6274	8,0000	1608,5	205887	6,2383	2,70927
513	263 169	135 005 697	22,6495	8,0052	1611,6	206692	6,2403	2,71012
514	264 196	135 796 744	22,6716	8,0104	1614,8	207499	6,2422	2,71096

n	n^2	n^3	\sqrt{n}	$\sqrt[3]{n}$	πn	$\frac{\pi}{4}n^2$	$\ln n$	$\lg n$
515	265 225	136 590 875	22,6936	8,0156	1617,9	208307	6,2442	2,71181
516	266 256	137 388 096	22,7156	8,0208	1621,1	209117	6,2461	2,71265
517	267 289	138 188 413	22,7376	8,0260	1624,2	209928	6,2480	2,71349
518	268 324	138 991 832	22,7596	8,0311	1627,3	210741	6,2500	2,71433
519	269 361	139 798 359	22,7816	8,0363	1630,5	211556	6,2519	2,71517
520	270 400	140 608 000	22,8035	8,0415	1633,6	212372	6,2538	2,71600
521	271 441	141 420 761	22,8254	8,0466	1636,8	213189	6,2558	2,71684
522	272 484	142 236 648	22,8473	8,0517	1639,9	214008	6,2577	2,71767
523	273 529	143 055 667	22,8692	8,0569	1643,1	214829	6,2596	2,71850
524	274 576	143 877 824	22,8910	8,0620	1646,2	215651	6,2615	2,71933
525	275 625	144 703 125	22,9129	8,0671	1649,3	216475	6,2634	2,72016
526	276 676	145 531 576	22,9347	8,0723	1652,5	217301	6,2653	2,72099
527	277 729	146 363 183	22,9565	8,0774	1655,6	218128	6,2672	2,72181
528	278 784	147 197 952	22,9783	8,0825	1658,8	218956	6,2691	2,72263
529	279 841	148 035 889	23,0000	8,0876	1661,9	219787	6,2710	2,72346
530	280 900	148 877 000	23,0217	8,0927	1665,0	220618	6,2729	2,72428
531	281 961	149 721 291	23,0434	8,0978	1668,2	221452	6,2748	2,72509
532	283 024	150 568 768	23,0651	8,1028	1671,3	222287	6,2766	2,72591
533	284 089	151 419 437	23,0868	8,1079	1674,5	223123	6,2785	2,72673
534	285 156	152 273 304	23,1084	8,1130	1677,6	223961	6,2804	2,72754
535	286 225	153 130 375	23,1301	8,1180	1680,8	224801	6,2823	2,72835
536	287 296	153 990 656	23,1517	8,1231	1683,9	225642	6,2841	2,72916
537	288 369	154 854 153	23,1733	8,1281	1687,0	226484	6,2860	2,72997
538	289 444	155 720 872	23,1948	8,1332	1690,2	227329	6,2879	2,73078
539	290 521	156 590 819	23,2164	8,1382	1693,3	228175	6,2897	2,73159
540	291 600	157 464 000	23,2379	8,1433	1696,5	229022	6,2916	2,73239
541	292 681	158 340 421	23,2594	8,1483	1699,6	229871	6,2934	2,73320
542	293 764	159 220 088	23,2809	8,1533	1702,7	230722	6,2953	2,73400
543	294 849	160 103 007	23,3024	8,1583	1705,9	231574	6,2971	2,73480
544	295 936	160 989 184	23,3238	8,1633	1709,0	232428	6,2989	2,73560
545	297 025	161 878 625	23,3452	8,1683	1712,2	233283	6,3008	2,73640
546	298 116	162 771 336	23,3666	8,1733	1715,3	234140	6,3026	2,73719
547	299 209	163 667 323	23,3880	8,1783	1718,5	234998	6,3044	2,73799
548	300 304	164 566 592	23,4094	8,1833	1721,6	235858	6,3063	2,73878
549	301 401	165 469 149	23,4307	8,1882	1724,7	236720	6,3081	2,73957
550	302 500	166 375 000	23,4521	8,1932	1727,9	237583	6,3099	2,74036
551	303 601	167 284 151	23,4734	8,1982	1731,0	238448	6,3117	2,74115
552	304 704	168 196 608	23,4947	8,2031	1734,2	239314	6,3135	2,74194
553	305 809	169 112 377	23,5160	8,2081	1737,3	240182	6,3154	2,74273
554	306 916	170 031 464	23,5372	8,2130	1740,4	241051	6,3172	2,74351
555	308 025	170 953 875	23,5584	8,2180	1743,6	241922	6,3190	2,74429
556	309 136	171 879 616	23,5797	8,2229	1746,7	242795	6,3208	2,74507
557	310 249	172 808 693	23,6008	8,2278	1749,9	243669	6,3226	2,74586
558	311 364	173 741 112	23,6220	8,2327	1753,0	244545	6,3244	2,74663
559	312 481	174 676 879	23,6432	8,2377	1756,2	245422	6,3261	2,74741

n	n^2	n^3	\sqrt{n}	$\sqrt[3]{n}$	πn	$\frac{\pi}{4} n^2$	$\ln n$	$\lg n$
560	313 600	175 616 000	23,6643	8,2426	1759,3	246301	6,3279	2,74819
561	314 721	176 558 481	23,6854	8,2475	1762,4	247181	6,3297	2,74896
562	315 844	177 504 328	23,7065	8,2524	1765,6	248063	6,3315	2,74974
563	316 969	178 453 547	23,7276	8,2573	1768,7	248947	6,3333	2,75051
564	318 096	179 406 144	23,7487	8,2621	1771,9	249832	6,3351	2,75128
565	319 225	180 362 125	23,7697	8,2670	1775,0	250719	6,3368	2,75205
566	320 356	181 321 496	23,7908	8,2719	1778,1	251607	6,3386	2,75282
567	321 489	182 284 263	23,8118	8,2768	1781,3	252497	6,3404	2,75358
568	322 624	183 250 432	23,8328	8,2816	1784,4	253388	6,3421	2,75435
569	323 761	184 220 009	23,8537	8,2865	1787,6	254281	6,3439	2,75511
570	324 900	185 193 000	23,8747	8,2913	1790,7	255176	6,3456	2,75587
571	326 041	186 169 411	23,8956	8,2962	1793,8	256072	6,3474	2,75664
572	327 184	187 149 248	23,9165	8,3010	1797,0	256970	6,3491	2,75740
573	328 329	188 132 517	23,9374	8,3059	1800,1	257869	6,3509	2,75815
574	329 476	189 119 224	23,9583	8,3107	1803,3	258770	6,3526	2,75891
575	330 625	190 109 375	23,9792	8,3155	1806,4	259672	6,3544	2,75967
576	331 776	191 102 976	24,0000	8,3203	1809,6	260576	6,3561	2,76042
577	332 929	192 100 033	24,0208	8,3251	1812,7	261482	6,3578	2,76118
578	334 084	193 100 552	24,0416	8,3300	1815,8	262389	6,3596	2,76193
579	335 241	194 104 539	24,0624	8,3348	1819,0	263298	6,3613	2,76268
580	336 400	195 112 000	24,0832	8,3396	1822,1	264208	6,3630	2,76343
581	337 561	196 122 941	24,1039	8,3443	1825,3	265120	6,3648	2,76418
582	338 724	197 137 368	24,1247	8,3491	1828,4	266033	6,3665	2,76492
583	339 889	198 155 287	24,1454	8,3539	1831,5	266948	6,3682	2,76567
584	341 056	199 176 704	24,1661	8,3587	1834,7	267865	6,3699	2,76641
585	342 225	200 201 625	24,1868	8,3634	1837,8	268783	6,3716	2,76716
586	343 396	201 230 056	24,2074	8,3682	1841,0	269703	6,3733	2,76790
587	344 569	202 262 003	24,2281	8,3730	1844,1	270624	6,3750	2,76864
588	345 744	203 297 472	24,2487	8,3777	1847,3	271547	6,3767	2,76938
589	346 921	204 336 469	24,2693	8,3825	1850,4	272471	6,3784	2,77012
590	348 100	205 379 000	24,2899	8,3872	1853,5	273397	6,3801	2,77085
591	349 281	206 425 071	24,3105	8,3919	1856,7	274325	6,3818	2,77159
592	350 464	207 474 688	24,3311	8,3967	1859,8	275254	6,3835	2,77232
593	351 649	208 527 857	24,3516	8,4014	1863,0	276184	6,3852	2,77305
594	352 836	209 584 584	24,3721	8,4061	1866,1	277117	6,3869	2,77379
595	354 025	210 644 875	24,3926	8,4108	1869,2	278051	6,3886	2,77452
596	355 216	211 708 736	24,4131	8,4155	1872,4	278986	6,3902	2,77525
597	356 409	212 776 173	24,4336	8,4202	1875,5	279923	6,3919	2,77597
598	357 604	213 847 192	24,4540	8,4249	1878,7	280862	6,3936	2,77670
599	358 801	214 921 799	24,4745	8,4296	1881,8	281802	6,3953	2,77743
600	360 000	216 000 000	24,4949	8,4343	1885,0	282743	6,3969	2,77815
601	361 201	217 081 801	24,5153	8,4390	1888,1	283687	6,3986	2,77887
602	362 404	218 167 208	24,5357	8,4437	1891,2	284631	6,4003	2,77960
603	363 609	219 256 227	24,5561	8,4484	1894,4	285578	6,4019	2,78032
604	364 816	220 348 864	24,5764	8,4530	1897,5	286526	6,4036	2,78104

n	n^2	n^3	\sqrt{n}	$\sqrt[3]{n}$	πn	$\frac{\pi}{4} n^2$	$\ln n$	$\lg n$
605	366 025	221 445 125	24,5967	8,4577	1900,7	287475	6,4052	2,78176
606	367 236	222 545 016	24,6171	8,4623	1903,8	288426	6,4069	2,78247
607	368 449	223 648 543	24,6374	8,4670	1906,9	289379	6,4085	2,78319
608	369 664	224 755 712	24,6577	8,4716	1910,1	290333	6,4102	2,78390
609	370 881	225 866 529	24,6779	8,4763	1913,2	291289	6,4118	2,78462
610	372 100	226 981 000	24,6982	8,4809	1916,4	292247	6,4135	2,78533
611	373 321	228 099 131	24,7184	8,4856	1919,5	293206	6,4151	2,78604
612	374 544	229 220 928	24,7386	8,4902	1922,7	294166	6,4167	2,78675
613	375 769	230 346 397	24,7588	8,4948	1925,8	295128	6,4184	2,78746
614	376 996	231 475 544	24,7790	8,4994	1928,9	296092	6,4200	2,78817
615	378 225	232 608 375	24,7992	8,5040	1932,1	297057	6,4216	2,78888
616	379 456	233 744 896	24,8193	8,5086	1935,2	298024	6,4232	2,78958
617	380 689	234 885 113	24,8395	8,5132	1938,4	298992	6,4249	2,79029
618	381 924	236 029 032	24,8596	8,5178	1941,5	299962	6,4265	2,79099
619	383 161	237 176 659	24,8797	8,5224	1944,6	300934	6,4281	2,79169
620	384 400	238 328 000	24,8998	8,5270	1947,8	301907	6,4297	2,79239
621	385 641	239 483 061	24,9199	8,5316	1950,9	302882	6,4313	2,79309
622	386 884	240 641 848	24,9399	8,5362	1954,1	303858	6,4329	2,79379
623	388 129	241 804 367	24,9600	8,5408	1957,2	304836	6,4345	2,79449
624	389 376	242 970 624	24,9800	8,5453	1960,4	305815	6,4362	2,79518
625	390 625	244 140 625	25,0000	8,5499	1963,5	306796	6,4378	2,79588
626	391 876	245 314 376	25,0200	8,5544	1966,6	307779	6,4394	2,79657
627	393 129	246 491 883	25,0400	8,5590	1969,8	308763	6,4409	2,79727
628	394 384	247 673 152	25,0599	8,5635	1972,9	309748	6,4425	2,79796
629	395 641	248 858 189	25,0799	8,5681	1976,1	310736	6,4441	2,79865
630	396 900	250 047 000	25,0998	8,5726	1979,2	311725	6,4457	2,79934
631	398 161	251 239 591	25,1197	8,5772	1982,3	312715	6,4473	2,80003
632	399 424	252 435 968	25,1396	8,5817	1985,5	313707	6,4489	2,80072
633	400 689	253 636 137	25,1595	8,5862	1988,6	314700	6,4505	2,80140
634	401 956	254 840 104	25,1794	8,5907	1991,8	315696	6,4520	2,80209
635	403 225	256 047 875	25,1992	8,5952	1994,9	316692	6,4536	2,80277
636	404 496	257 259 456	25,2190	8,5997	1998,1	317690	6,4552	2,80346
637	405 769	258 474 853	25,2389	8,6043	2001,2	318690	6,4568	2,80414
638	407 044	259 694 072	25,2587	8,6088	2004,3	319692	6,4583	2,80482
639	408 321	260 917 119	25,2784	8,6132	2007,5	320695	6,4599	2,80550
640	409 600	262 144 000	25,2982	8,6177	2010,6	321699	6,4615	2,80618
641	410 881	263 374 721	25,3180	8,6222	2013,8	322705	6,4630	2,80686
642	412 164	264 609 288	25,3377	8,6267	2016,9	323713	6,4646	2,80754
643	413 449	265 847 707	25,3574	8,6312	2020,0	324722	6,4661	2,80821
644	414 736	267 089 984	25,3772	8,6357	2023,2	325733	6,4677	2,80889
645	416 025	268 336 125	25,3969	8,6401	2026,3	326745	6,4693	2,80956
646	417 316	269 586 136	25,4165	8,6446	2029,5	327759	6,4708	2,81023
647	418 609	270 840 023	25,4362	8,6490	2032,6	328775	6,4723	2,81090
648	419 904	272 097 792	25,4558	8,6535	2035,8	329792	6,4739	2,81158
649	421 201	273 359 449	25,4755	8,6579	2038,9	330810	6,4754	2,81224

n	n^2	n^3	\sqrt{n}	$\sqrt[3]{n}$	πn	$\frac{\pi}{4}n^2$	$\ln n$	$\lg n$
650	422 500	274 625 000	25,4951	8,6624	2042,0	331831	6,4770	2,81291
651	423 801	275 894 451	25,5147	8,6668	2045,2	332853	6,4785	2,81358
652	425 104	277 167 808	25,5343	8,6713	2048,3	333876	6,4800	2,81425
653	426 409	278 445 077	25,5539	8,6757	2051,3	334901	6,4816	2,81491
654	427 716	279 726 264	25,5734	8,6801	2054,6	335927	6,4831	2,81558
655	429 025	281 011 375	25,5930	8,6845	2057,7	336955	6,4846	2,81624
656	430 336	282 300 416	25,6125	8,6890	2060,9	337985	6,4862	2,81690
657	431 649	283 593 393	25,6320	8,6934	2064,0	339016	6,4877	2,81757
658	432 964	284 890 312	25,6515	8,6978	2067,2	340049	6,4892	2,81823
659	434 281	286 191 179	25,6710	8,7022	2070,3	341083	6,4907	2,81889
660	435 600	287 496 000	25,6905	8,7066	2073,5	342119	6,4922	2,81954
661	436 921	288 804 781	25,7099	8,7110	2076,6	343157	6,4938	2,82020
662	438 244	290 117 528	25,7294	8,7154	2079,7	344196	6,4953	2,82086
663	439 569	291 434 247	25,7488	8,7198	2082,9	345237	6,4968	2,82151
664	440 896	292 754 944	25,7682	8,7241	2086,0	346279	6,4983	2,82217
665	442 225	294 079 625	25,7876	8,7285	2089,2	347323	6,4998	2,82282
666	443 556	295 408 296	25,8070	8,7329	2092,3	348368	6,5013	2,82347
667	444 889	296 740 963	25,8263	8,7373	2095,4	349415	6,5028	2,82413
668	446 224	298 077 632	25,8457	8,7416	2098,6	350464	6,5043	2,82478
669	447 561	299 418 309	25,8650	8,7460	2101,7	351514	6,5058	2,82543
670	448 900	300 763 000	25,8844	8,7503	2104,9	352565	6,5073	2,82607
671	450 241	302 111 711	25,9037	8,7547	2108,0	353618	6,5088	2,82672
672	451 584	303 464 448	25,9230	8,7590	2111,2	354673	6,5103	2,82737
673	452 929	304 821 217	25,9422	8,7634	2114,3	355730	6,5117	2,82802
674	454 276	306 182 024	25,9615	8,7677	2117,4	356788	6,5132	2,82866
675	455 625	307 546 875	25,9808	8,7721	2120,6	357847	6,5147	2,82930
676	456 976	308 915 776	26,0000	8,7764	2123,7	358908	6,5162	2,82995
677	458 329	310 288 733	26,0192	8,7807	2126,9	359971	6,5177	2,83059
678	459 684	311 665 752	26,0384	8,7850	2130,0	361035	6,5191	2,83123
679	461 041	313 046 839	26,0576	8,7893	2133,1	362101	6,5206	2,83187
680	462 400	314 432 000	26,0768	8,7937	2136,3	363168	6,5221	2,83251
681	463 761	315 821 241	26,0960	8,7980	2139,4	364237	6,5236	2,83315
682	465 124	317 214 568	26,1151	8,8023	2142,6	365308	6,5250	2,83378
683	466 489	318 611 987	26,1343	8,8066	2145,7	366380	6,5265	2,83442
684	467 856	320 013 504	26,1534	8,8109	2148,8	367453	6,5280	2,83506
685	469 225	321 419 125	26,1725	8,8152	2152,0	368528	6,5294	2,83569
686	470 596	322 828 856	26,1916	8,8194	2155,1	369605	6,5309	2,83632
687	471 969	324 242 703	26,2107	8,8237	2158,3	370684	6,5323	2,83696
688	473 344	325 660 672	26,2298	8,8280	2161,4	371764	6,5338	2,83759
689	474 721	327 082 769	26,2488	8,8323	2164,6	372845	6,5352	2,83822
690	476 100	328 509 000	26,2679	8,8366	2167,7	373928	6,5367	2,83885
691	477 481	329 939 371	26,2869	8,8408	2170,8	375013	6,5381	2,83948
692	478 864	331 373 888	26,3059	8,8451	2174,0	376099	6,5396	2,84011
693	480 249	332 812 557	26,3249	8,8493	2177,1	377187	6,5410	2,84073
694	481 636	334 255 384	26,3439	8,8536	2180,3	378276	6,5425	2,84136

n	n^2	n^3	\sqrt{n}	$\sqrt[3]{n}$	πn	$\frac{\pi}{4}n^2$	$\ln n$	$\lg n$
695	483 025	335 702 375	26,3629	8,8578	2183,4	379367	6,5439	2,84198
696	484 416	337 153 536	26,3818	8,8621	2186,5	380459	6,5453	2,84261
697	485 809	338 608 873	26,4008	8,8663	2189,7	381553	6,5468	2,84323
698	487 204	340 068 392	26,4197	8,8706	2192,8	382649	6,5482	2,84386
699	488 601	341 532 099	26,4386	8,8748	2196,0	383746	6,5497	2,84448
700	490 000	343 000 000	26,4575	8,8790	2199,1	384845	6,5511	2,84510
701	491 401	344 472 101	26,4764	8,8833	2202,3	385945	6,5525	2,84572
702	492 804	345 948 408	26,4953	8,8875	2205,4	387047	6,5539	2,84634
703	494 209	347 428 927	26,5141	8,8917	2208,5	388151	6,5554	2,84696
704	495 616	348 913 664	26,5330	8,8959	2211,7	389256	6,5568	2,84757
705	497 025	350 402 625	26,5518	8,9001	2214,8	390363	6,5582	2,84819
706	498 436	351 895 816	26,5707	8,9043	2218,0	391471	6,5596	2,84880
707	499 849	353 393 243	26,5895	8,9085	2221,1	392580	6,5610	2,84942
708	501 264	354 894 912	26,6083	8,9127	2224,2	393692	6,5624	2,85003
709	502 681	356 400 829	26,6271	8,9169	2227,4	394805	6,5639	2,85065
710	504 100	357 911 000	26,6458	8,9211	2230,5	395919	6,5653	2,85126
711	505 521	359 425 431	26,6646	8,9253	2233,7	397035	6,5667	2,85187
712	506 944	360 944 128	26,6833	8,9295	2236,8	398153	6,5681	2,85248
713	508 369	362 467 097	26,7021	8,9337	2240,0	399272	6,5695	2,85309
714	509 796	363 994 344	26,7208	8,9378	2243,1	400393	6,5709	2,85370
715	511 225	365 525 875	26,7395	8,9420	2246,2	401515	6,5723	2,85431
716	512 656	367 061 696	26,7582	8,9462	2249,4	402639	6,5737	2,85491
717	514 089	368 601 813	26,7769	8,9503	2252,5	403765	6,5751	2,85552
718	515 524	370 146 232	26,7955	8,9545	2255,7	404892	6,5765	2,85612
719	516 961	371 694 959	26,8142	8,9587	2258,8	406020	6,5779	2,85673
720	518 400	373 248 000	26,8328	8,9628	2261,9	407150	6,5793	2,85733
721	519 841	374 805 361	26,8514	8,9670	2265,1	408282	6,5806	2,85794
722	521 284	376 367 048	26,8701	8,9711	2268,2	409415	6,5820	2,85854
723	522 729	377 933 067	26,8887	8,9752	2271,4	410550	6,5834	2,85914
724	524 176	379 503 424	26,9072	8,9794	2274,5	411687	6,5848	2,85974
725	525 625	381 078 125	26,9258	8,9835	2277,7	412825	6,5862	2,86034
726	527 076	382 657 176	26,9444	8,9876	2280,8	413965	6,5876	2,86094
727	528 529	384 240 583	26,9629	8,9918	2283,9	415106	6,5889	2,86153
728	529 984	385 828 352	26,9815	8,9959	2287,1	416248	6,5903	2,86213
729	531 441	387 420 489	27,0000	9,0000	2290,2	417393	6,5917	2,86273
730	532 900	389 017 000	27,0185	9,0041	2293,4	418539	6,5930	2,86332
731	534 361	390 617 891	27,0370	9,0082	2296,5	419686	6,5944	2,86392
732	535 824	392 223 168	27,0555	9,0123	2299,6	420835	6,5958	2,86451
733	537 289	393 832 837	27,0740	9,0164	2302,8	421986	6,5971	2,86510
734	538 756	395 446 904	27,0924	9,0205	2305,9	423138	6,5985	2,86570
735	540 225	397 065 375	27,1109	9,0246	2309,1	424292	6,5999	2,86629
736	541 696	398 688 256	27,1293	9,0287	2312,2	425447	6,6012	2,86688
737	543 169	400 315 553	27,1477	9,0328	2315,4	426604	6,6026	2,86747
738	544 644	401 947 272	27,1662	9,0369	2318,5	427762	6,6039	2,86806
739	546 121	403 583 419	27,1846	9,0410	2321,6	428922	6,6053	2,86864

n	n^2	n^3	\sqrt{n}	$\sqrt[3]{n}$	πn	$\frac{\pi}{4}n^2$	$\ln n$	$\lg n$
740	547 600	405 224 000	27,2029	9,0450	2324,8	430084	6,6067	2,86923
741	549 081	406 869 021	27,2213	9,0491	2327,9	431247	6,6080	2,86982
742	550 564	408 518 488	27,2397	9,0532	2331,1	432412	6,6093	2,87040
743	552 049	410 172 407	27,2580	9,0572	2334,2	433578	6,6107	2,87099
744	553 536	411 830 784	27,2764	9,0613	2337,3	434746	6,6120	2,87157
745	555 025	413 493 625	27,2947	9,0654	2340,5	435916	6,6134	2,87216
746	556 516	415 160 936	27,3130	9,0694	2343,6	437087	6,6147	2,87274
747	558 009	416 832 723	27,3313	9,0735	2346,8	438259	6,6161	2,87332
748	559 504	418 508 992	27,3496	9,0775	2349,9	439433	6,6174	2,87390
749	561 001	420 189 749	27,3679	9,0816	2353,1	440609	6,6187	2,87448
750	562 500	421 875 000	27,3861	9,0856	2356,2	441786	6,6201	2,87506
751	564 001	423 564 751	27,4044	9,0896	2359,3	442965	6,6214	2,87564
752	565 504	425 259 008	27,4226	9,0937	2362,5	444146	6,6227	2,87622
753	567 009	426 957 777	27,4408	9,0977	2365,6	445328	6,6241	2,87679
754	568 516	428 661 064	27,4591	9,1017	2368,8	446511	6,6254	2,87737
755	570 025	430 368 875	27,4773	9,1057	2371,9	447697	6,6267	2,87795
756	571 536	432 081 216	27,4955	9,1098	2375,0	448883	6,6280	2,87852
757	573 049	433 798 093	27,5136	9,1138	2378,2	450072	6,6294	2,87910
758	574 564	435 519 512	27,5318	9,1178	2381,3	451262	6,6307	2,87967
759	576 081	437 245 479	27,5500	9,1218	2384,5	452453	6,6320	2,88024
760	577 600	438 976 000	27,5681	9,1258	2387,6	453646	6,6333	2,88081
761	579 121	440 711 081	27,5862	9,1298	2390,8	454841	6,6346	2,88138
762	580 644	442 450 728	27,6043	9,1338	2393,9	456037	6,6359	2,88195
763	582 169	444 194 947	27,6225	9,1378	2397,0	457234	6,6373	2,88252
764	583 696	445 943 744	27,6405	9,1418	2400,2	458434	6,6386	2,88309
765	585 225	447 697 125	27,6586	9,1458	2403,3	459635	6,6399	2,88366
766	586 756	449 455 096	27,6767	9,1498	2406,5	460837	6,6412	2,88423
767	588 289	451 217 663	27,6948	9,1537	2409,6	462041	6,6425	2,88480
768	589 824	452 984 832	27,7128	9,1577	2412,7	463247	6,6438	2,88536
769	591 361	454 756 609	27,7308	9,1617	2415,9	464454	6,6451	2,88593
770	592 900	456 533 000	27,7489	9,1657	2419,0	465663	6,6464	2,88649
771	594 441	458 314 011	27,7669	9,1696	2422,2	466873	6,6477	2,88705
772	595 984	460 099 648	27,7849	9,1736	2425,3	468085	6,6490	2,88762
773	597 529	461 889 917	27,8029	9,1775	2428,5	469298	6,6503	2,88818
774	599 076	463 684 824	27,8209	9,1815	2431,6	470513	6,6516	2,88874
775	600 625	465 484 375	27,8388	9,1855	2434,7	471730	6,6529	2,88930
776	602 176	467 288 576	27,8568	9,1894	2437,9	472948	6,6542	2,88986
777	603 729	469 097 433	27,8747	9,1933	2441,0	474168	6,6554	2,89042
778	605 284	470 910 952	27,8927	9,1973	2444,2	475389	6,6567	2,89098
779	606 841	472 729 139	27,9106	9,2012	2447,3	476612	6,6580	2,89154
780	608 400	474 552 000	27,9285	9,2052	2450,4	477836	6,6593	2,89209
781	609 961	476 379 541	27,9464	9,2091	2453,6	479062	6,6606	2,89265
782	611 524	478 211 768	27,9643	9,2130	2456,7	480290	6,6619	2,89321
783	613 089	480 048 687	27,9821	9,2170	2459,9	481519	6,6631	2,89376
784	614 656	481 890 304	28,0000	9,2209	2463,0	482750	6,6644	2,89432

n	n^2	n^3	\sqrt{n}	$\sqrt[3]{n}$	πn	$\frac{\pi}{4}n^2$	$\ln n$	$\lg n$
785	616 225	483 736 625	28,0179	9,2248	2466,2	483982	6,6657	2,89487
786	617 796	485 587 656	28,0357	9,2287	2469,3	485216	6,6670	2,89542
787	619 369	487 443 403	28,0535	9,2326	2472,4	486451	6,6682	2,89597
788	620 944	489 303 872	28,0713	9,2365	2475,6	487688	6,6695	2,89653
789	622 521	491 169 069	28,0891	9,2404	2478,7	488927	6,6708	2,89708
790	624 100	493 039 000	28,1069	9,2443	2481,9	490167	6,6720	2,89763
791	625 681	494 913 671	28,1247	9,2482	2485,0	491409	6,6733	2,89818
792	627 264	496 793 088	28,1425	9,2521	2488,1	492652	6,6746	2,89873
793	628 849	498 677 257	28,1603	9,2560	2491,3	493897	6,6758	2,89927
794	630 436	500 566 184	28,1780	9,2599	2494,4	495143	6,6771	2,89982
795	632 025	502 459 875	28,1957	9,2638	2497,6	496391	6,6783	2,90037
796	633 616	504 358 336	28,2135	9,2677	2500,7	497641	6,6796	2,90091
797	635 209	506 261 573	28,2312	9,2716	2503,8	498892	6,6809	2,90146
798	636 804	508 169 592	28,2489	9,2754	2507,0	500145	6,6821	2,90200
799	638 401	510 082 399	28,2666	9,2793	2510,1	501399	6,6834	2,90255
800	640 000	512 000 000	28,2843	9,2832	2513,3	502655	6,6846	2,90309
801	641 601	513 922 401	28,3019	9,2870	2516,4	503912	6,6859	2,90363
802	643 204	515 849 608	28,3196	9,2909	2519,6	505171	6,6871	2,90417
803	644 809	517 781 627	28,3373	9,2948	2522,7	506432	6,6884	2,90472
804	646 416	519 718 464	28,3549	9,2986	2525,8	507694	6,6896	2,90526
805	648 025	521 660 125	28,3725	9,3025	2529,0	508958	6,6908	2,90580
806	649 636	523 606 616	28,3901	9,3063	2532,1	510223	6,6921	2,90634
807	651 249	525 557 943	28,4077	9,3102	2535,3	511490	6,6933	2,90687
808	652 864	527 514 112	28,4253	9,3140	2538,4	512758	6,6946	2,90741
809	654 481	529 475 129	28,4429	9,3179	2541,5	514028	6,6958	2,90795
810	656 100	531 441 000	28,4605	9,3217	2544,7	515300	6,6970	2,90849
811	657 721	533 411 731	28,4781	9,3255	2547,8	516573	6,6983	2,90902
812	659 344	535 387 328	28,4956	9,3294	2551,0	517848	6,6995	2,90956
813	660 969	537 367 797	28,5132	9,3332	2554,1	519124	6,7007	2,91009
814	662 596	539 353 144	28,5307	9,3370	2557,3	520402	6,7020	2,91062
815	664 225	541 343 375	28,5482	9,3408	2560,4	521681	6,7032	2,91116
816	665 856	543 338 496	28,5657	9,3447	2563,5	522962	6,7044	2,91169
817	667 489	545 338 513	28,5832	9,3485	2566,7	524245	6,7056	2,91222
818	669 124	547 343 432	28,6007	9,3523	2569,8	525529	6,7069	2,91275
819	670 761	549 353 259	28,6182	9,3561	2573,0	526814	6,7081	2,91328
820	672 400	551 368 000	28,6356	9,3599	2576,1	528102	6,7093	2,91381
821	674 041	553 387 661	28,6531	9,3637	2579,2	529391	6,7105	2,91434
822	675 684	555 412 248	28,6705	9,3675	2582,4	530681	6,7117	2,91487
823	677 329	557 441 767	28,6880	9,3713	2585,5	531973	6,7130	2,91540
824	678 976	559 476 224	28,7054	9,3751	2588,7	533267	6,7142	2,91593
825	680 625	561 515 625	28,7228	9,3789	2591,8	534562	6,7154	2,91645
826	682 276	563 559 976	28,7402	9,3827	2595,0	535858	6,7166	2,91698
827	683 929	565 609 283	28,7576	9,3865	2598,1	537157	6,7178	2,91751
828	685 584	567 663 552	28,7750	9,3902	2601,2	538456	6,7190	2,91803
829	687 241	569 722 789	28,7924	9,3940	2604,4	539758	6,7202	2,91855

n	n^2	n^3	\sqrt{n}	$\sqrt[3]{n}$	πn	$\frac{\pi}{4} n^2$	$\ln n$	$\lg n$
830	688 900	571 787 000	28,8097	9,3978	2607,5	541061	6,7214	2,91908
831	690 561	573 856 191	28,8271	9,4016	2610,7	542365	6,7226	2,91960
832	692 224	575 930 368	28,8444	9,4053	2613,8	543671	6,7238	2,92012
833	693 889	578 009 537	28,8617	9,4091	2616,9	544979	6,7250	2,92065
834	695 556	580 093 704	28,8791	9,4129	2620,1	546288	6,7262	2,92117
835	697 225	582 182 875	28,8964	9,4166	2623,2	547599	6,7274	2,92169
836	698 896	584 277 056	28,9137	9,4204	2626,4	548912	6,7286	2,92221
837	700 569	586 376 253	28,9310	9,4241	2629,5	550226	6,7298	2,92273
838	702 244	588 480 472	28,9482	9,4279	2632,7	551541	6,7310	2,92324
839	703 921	590 589 719	28,9655	9,4316	2635,8	552858	6,7322	2,92376
840	705 600	592 704 000	28,9828	9,4354	2638,9	554177	6,7334	2,92428
841	707 281	594 823 321	29,0000	9,4391	2642,1	555497	6,7346	2,92480
842	708 964	596 947 688	29,0172	9,4429	2645,2	556819	6,7358	2,92531
843	710 649	599 077 107	29,0345	9,4466	2648,4	558142	6,7370	2,92583
844	712 336	601 211 584	29,0517	9,4503	2651,5	559467	6,7382	2,92634
845	714 025	603 351 125	29,0689	9,4541	2654,6	560794	6,7393	2,92686
846	715 716	605 495 736	29,0861	9,4578	2657,8	562122	6,7405	2,92737
847	717 409	607 645 423	29,1033	9,4615	2660,9	563452	6,7417	2,92788
848	719 104	609 800 192	29,1204	9,4652	2664,1	564783	6,7429	2,92840
849	720 801	611 960 049	29,1376	9,4690	2667,2	566116	6,7441	2,92891
850	722 500	614 125 000	29,1548	9,4727	2670,4	567450	6,7452	2,92942
851	724 201	616 295 051	29,1719	9,4764	2673,5	568786	6,7464	2,92993
852	725 904	618 470 208	29,1890	9,4801	2676,6	570124	6,7476	2,93044
853	727 609	620 650 477	29,2062	9,4838	2679,8	571463	6,7488	2,93095
854	729 316	622 835 864	29,2233	9,4875	2682,9	572803	6,7499	2,93146
855	731 025	625 026 375	29,2404	9,4912	2686,1	574146	6,7511	2,93197
856	732 736	627 222 016	29,2575	9,4949	2689,2	575490	6,7523	2,93247
857	734 449	629 422 793	29,2746	9,4986	2692,3	576835	6,7534	2,93298
858	736 164	631 628 712	29,2916	9,5023	2695,5	578182	6,7546	2,93349
859	737 881	633 839 779	29,3087	9,5060	2698,6	579530	6,7558	2,93399
860	739 600	636 056 000	29,3258	9,5097	2701,8	580880	6,7569	2,93450
861	741 321	638 277 381	29,3428	9,5134	2704,9	582232	6,7581	2,93500
862	743 044	640 503 928	29,3598	9,5171	2708,1	583585	6,7593	2,93551
863	744 769	642 735 647	29,3769	9,5207	2711,2	584940	6,7604	2,93601
864	746 496	644 972 544	29,3939	9,5244	2714,3	586297	6,7616	2,93651
865	748 225	647 214 625	29,4109	9,5281	2717,5	587655	6,7627	2,93702
866	749 956	649 461 896	29,4279	9,5317	2720,6	589014	6,7639	2,93752
867	751 689	651 714 363	29,4449	9,5354	2723,8	590375	6,7650	2,93802
868	753 424	653 972 032	29,4618	9,5391	2726,9	591738	6,7662	2,93852
869	755 161	656 234 909	29,4788	9,5427	2730,0	593102	6,7673	2,93902
870	756 900	658 503 000	29,4958	9,5464	2733,2	594468	6,7685	2,93952
871	758 641	660 776 311	29,5127	9,5501	2736,3	595835	6,7696	2,94002
872	760 384	663 054 848	29,5296	9,5537	2739,5	597204	6,7708	2,94052
873	762 129	665 338 617	29,5466	9,5574	2742,6	598575	6,7719	2,94101
874	763 876	667 627 624	29,5635	9,5610	2745,8	599947	6,7731	2,94151

n	n^2	n^3	\sqrt{n}	$\sqrt[3]{n}$	πn	$\frac{\pi}{4} n^2$	$\ln n$	$\lg n$
875	765 625	669 921 875	29,5804	9,5647	2748,9	601320	6,7742	2,94201
876	767 376	672 221 376	29,5973	9,5683	2752,0	602696	6,7754	2,94250
877	769 129	674 526 133	29,6142	9,5719	2755,2	604073	6,7765	2,94300
878	770 884	676 836 152	29,6311	9,5756	2758,3	605451	6,7776	2,94349
879	772 641	679 151 439	29,6479	9,5792	2761,5	606831	6,7788	2,94399
880	774 400	681 472 000	29,6648	9,5828	2764,6	608212	6,7799	2,94448
881	776 161	683 797 841	29,6816	9,5865	2767,7	609595	6,7811	2,94498
882	777 924	686 128 968	29,6985	9,5901	2770,9	610980	6,7822	2,94547
883	779 689	688 465 387	29,7153	9,5937	2774,0	612366	6,7833	2,94596
884	781 456	690 807 104	29,7321	9,5973	2777,2	613754	6,7845	2,94645
885	783 225	693 154 125	29,7489	9,6010	2780,3	615143	6,7856	2,94694
886	784 996	695 506 456	29,7658	9,6046	2783,5	616534	6,7867	2,94743
887	786 769	697 864 103	29,7825	9,6082	2786,6	617927	6,7878	2,94792
888	788 544	700 227 072	29,7993	9,6118	2789,7	619321	6,7890	2,94841
889	790 321	702 595 369	29,8161	9,6154	2792,9	620717	6,7901	2,94890
890	792 100	704 969 000	29,8329	9,6190	2796,0	622114	6,7912	2,94939
891	793 881	707 347 971	29,8496	9,6226	2799,2	623513	6,7923	2,94988
892	795 664	709 732 288	29,8664	9,6262	2802,3	624913	6,7935	2,95036
893	797 449	712 121 957	29,8831	9,6298	2805,4	626315	6,7946	2,95085
894	799 236	714 516 984	29,8998	9,6334	2808,6	627718	6,7957	2,95134
895	801 025	716 917 375	29,9166	9,6370	2811,7	629124	6,7968	2,95182
896	802 816	719 323 136	29,9333	9,6406	2814,9	630530	6,7979	2,95231
897	804 609	721 734 273	29,9500	9,6442	2818,0	631938	6,7991	2,95279
898	806 404	724 150 792	29,9666	9,6477	2821,2	633348	6,8002	2,95328
899	808 201	726 572 699	29,9833	9,6513	2824,3	634760	6,8013	2,95376
900	810 000	729 000 000	30,0000	9,6549	2827,4	636173	6,8024	2,95424
901	811 801	731 432 701	30,0167	9,6585	2830,6	637587	6,8035	2,95472
902	813 604	733 870 808	30,0333	9,6620	2833,7	639003	6,8046	2,95521
903	815 409	736 314 327	30,0500	9,6656	2836,9	640421	6,8057	2,95569
904	817 216	738 763 264	30,0666	9,6692	2840,0	641840	6,8068	2,95617
905	819 025	741 217 625	30,0832	9,6727	2843,1	643261	6,8079	2,95665
906	820 836	743 677 416	30,0998	9,6763	2846,3	644683	6,8090	2,95713
907	822 649	746 142 643	30,1164	9,6799	2849,4	646107	6,8101	2,95761
908	824 464	748 613 312	30,1330	9,6834	2852,6	647533	6,8112	2,95809
909	826 281	751 089 429	30,1496	9,6870	2855,7	648960	6,8123	2,95856
910	828 100	753 571 000	30,1662	9,6905	2858,8	650388	6,8134	2,95904
911	829 921	756 058 031	30,1828	9,6941	2862,0	651818	6,8145	2,95952
912	831 744	758 550 528	30,1993	9,6976	2865,1	653250	6,8156	2,95999
913	833 569	761 048 497	30,2159	9,7012	2868,3	654684	6,8167	2,96047
914	835 396	763 551 944	30,2324	9,7047	2871,4	656118	6,8178	2,96095
915	837 225	766 060 875	30,2490	9,7082	2874,6	657555	6,8189	2,96142
916	839 056	768 575 296	30,2655	9,7118	2877,7	658993	6,8200	2,96190
917	840 889	771 095 213	30,2820	9,7153	2880,8	660433	6,8211	2,96237
918	842 724	773 620 632	30,2985	9,7188	2884,0	661874	6,8222	2,96284
919	844 561	776 151 559	30,3150	9,7224	2887,1	663317	6,8233	2,96332

n	n^2	n^3	\sqrt{n}	$\sqrt[3]{n}$	πn	$\frac{\pi}{4} n^2$	$\ln n$	$\lg n$
920	846 400	778 688 000	30,3315	9,7259	2890,3	664761	6,8244	2,96379
921	848 241	781 229 961	30,3480	9,7294	2893,4	666207	6,8255	2,96426
922	850 084	783 777 448	30,3645	9,7329	2896,5	667654	6,8265	2,96473
923	851 929	786 330 467	30,3809	9,7364	2899,7	669103	6,8276	2,96520
924	853 776	788 889 024	30,3974	9,7400	2902,8	670554	6,8287	2,96567
925	855 625	791 453 125	30,4138	9,7435	2906,0	672006	6,8298	2,96614
926	857 476	794 022 776	30,4302	9,7470	2909,1	673460	6,8309	2,96661
927	859 329	796 597 983	30,4467	9,7505	2912,3	674915	6,8320	2,96708
928	861 184	799 178 752	30,4631	9,7540	2915,4	676372	6,8330	2,96755
929	863 041	801 765 089	30,4795	9,7575	2918,5	677831	6,8341	2,96802
930	864 900	804 357 000	30,4959	9,7610	2921,7	679291	6,8352	2,96848
931	866 761	806 954 491	30,5123	9,7645	2924,8	680752	6,8363	2,96895
932	868 624	809 557 568	30,5287	9,7680	2928,0	682216	6,8373	2,96942
933	870 489	812 166 237	30,5450	9,7715	2931,1	683680	6,8384	2,96988
934	872 356	814 780 504	30,5614	9,7750	2934,2	685147	6,8395	2,97035
935	874 225	817 400 375	30,5778	9,7785	2937,4	686615	6,8405	2,97081
936	876 096	820 025 856	30,5941	9,7819	2940,5	688084	6,8416	2,97128
937	877 969	822 656 953	30,6105	9,7854	2943,7	689555	6,8427	2,97174
938	879 844	825 293 672	30,6268	9,7889	2946,8	691028	6,8437	2,97220
939	881 721	827 936 019	30,6431	9,7924	2950,0	692502	6,8448	2,97267
940	883 600	830 584 000	30,6594	9,7959	2953,1	693978	6,8459	2,97313
941	885 481	833 237 621	30,6757	9,7993	2956,2	695455	6,8469	2,97359
942	887 364	835 896 888	30,6920	9,8028	2959,4	696934	6,8480	2,97405
943	889 249	838 561 807	30,7083	9,8063	2962,5	698415	6,8491	2,97451
944	891 136	841 232 384	30,7246	9,8097	2965,7	699897	6,8501	2,97497
945	893 025	843 908 625	30,7409	9,8132	2968,8	701380	6,8512	2,97543
946	894 916	846 590 536	30,7571	9,8167	2971,9	702865	6,8522	2,97589
947	896 809	849 278 123	30,7734	9,8201	2975,1	704352	6,8533	2,97635
948	898 704	851 971 392	30,7896	9,8236	2978,2	705840	6,8544	2,97681
949	900 601	854 670 349	30,8058	9,8270	2981,4	707330	6,8554	2,97727
950	902 500	857 375 000	30,8221	9,8305	2984,5	708822	6,8565	2,97772
951	904 401	860 085 351	30,8383	9,8339	2987,7	710315	6,8575	2,97818
952	906 304	862 801 408	30,8545	9,8374	2990,8	711809	6,8586	2,97864
953	908 209	865 523 177	30,8707	9,8408	2993,9	713306	6,8596	2,97909
954	910 116	868 250 664	30,8869	9,8443	2997,1	714803	6,8607	2,97955
955	912 025	870 983 875	30,9031	9,8477	3000,2	716303	6,8617	2,98000
956	913 936	873 722 816	30,9192	9,8511	3003,4	717804	6,8628	2,98046
957	915 849	876 467 493	30,9354	9,8546	3006,5	719306	6,8638	2,98091
958	917 764	879 217 912	30,9516	9,8580	3009,6	720810	6,8648	2,98137
959	919 681	881 974 079	30,9677	9,8614	3012,8	722316	6,8659	2,98182
960	921 600	884 736 000	30,9839	9,8648	3015,9	723823	6,8669	2,98227
961	923 521	887 503 681	31,0000	9,8683	3019,1	725332	6,8680	2,98272
962	925 444	890 277 128	31,0161	9,8717	3022,2	726842	6,8690	2,98318
963	927 369	893 056 347	31,0322	9,8751	3025,4	728354	6,8701	2,98363
964	929 296	895 841 344	31,0483	9,8785	3028,5	729867	6,8711	2,98408

n	n^2	n^3	\sqrt{n}	$\sqrt[3]{n}$	πn	$\frac{\pi}{4} n^2$	$\ln n$	$\lg n$
965	931 225	898 632 125	31,0644	9,8819	3031,6	731382	6,8721	2,98453
966	933 156	901 428 696	31,0805	9,8854	3034,8	732899	6,8732	2,98498
967	935 089	904 231 063	31,0966	9,8888	3037,9	734417	6,8742	2,98543
968	937 024	907 039 232	31,1127	9,8922	3041,1	735937	6,8752	2,98588
969	938 961	909 853 209	31,1288	9,8956	3044,2	737458	6,8763	2,98632
970	940 900	912 673 000	31,1448	9,8990	3047,3	738981	6,8773	2,98677
971	942 841	915 498 611	31,1609	9,9024	3050,5	740506	6,8783	2,98722
972	944 784	918 330 048	31,1769	9,9058	3053,6	742032	6,8794	2,98767
973	946 729	921 167 317	31,1929	9,9092	3056,8	743559	6,8804	2,98811
974	948 676	924 010 024	31,2090	9,9126	3059,9	745088	6,8814	2,98856
975	950 625	926 859 375	31,2250	9,9160	3063,1	746619	6,8824	2,98900
976	952 576	929 714 176	31,2410	9,9194	3066,2	748151	6,8835	2,98945
977	954 529	932 574 833	31,2570	9,9227	3069,3	749685	6,8845	2,98989
978	956 484	935 441 352	31,2730	9,9261	3072,5	751221	6,8855	2,99034
979	958 441	938 313 739	31,2890	9,9295	3075,6	752758	6,8865	2,99078
980	960 400	941 192 000	31,3050	9,9329	3078,8	754296	6,8876	2,99123
981	962 361	944 076 141	31,3209	9,9363	3081,9	755837	6,8886	2,99167
982	964 324	946 966 168	31,3369	9,9396	3085,0	757378	6,8896	2,99211
983	966 289	949 862 087	31,3528	9,9430	3088,2	758922	6,8906	2,99255
984	968 256	952 763 904	31,3688	9,9464	3091,3	760466	6,8916	2,99300
985	970 225	955 671 625	31,3847	9,9497	3094,5	762013	6,8926	2,99344
986	972 196	958 585 256	31,4006	9,9531	3097,6	763561	6,8937	2,99388
987	974 169	961 504 803	31,4166	9,9565	3100,8	765111	6,8947	2,99432
988	976 144	964 430 272	31,4325	9,9598	3103,9	766662	6,8957	2,99476
989	978 121	967 361 669	31,4484	9,9632	3107,0	768214	6,8967	2,99520
990	980 100	970 299 000	31,4643	9,9666	3110,2	769769	6,8977	2,99564
991	982 081	973 242 271	31,4802	9,9699	3113,3	771325	6,8987	2,99607
992	984 064	976 191 488	31,4960	9,9733	3116,5	772882	6,8997	2,99651
993	986 049	979 146 657	31,5119	9,9766	3119,6	774441	6,9007	2,99695
994	988 036	982 107 784	31,5278	9,9800	3122,7	776002	6,9017	2,99739
995	990 025	985 074 875	31,5436	9,9833	3125,9	777564	6,9027	2,99782
996	992 016	988 047 936	31,5595	9,9866	3129,0	779128	6,9037	2,99826
997	994 009	991 026 973	31,5753	9,9900	3132,2	780693	6,9048	2,99870
998	996 004	994 011 992	31,5911	9,9933	3135,3	782260	6,9058	2,99913
999	998 001	997 002 999	31,6070	9,9967	3138,5	783828	6,9068	2,99957

II. Trigonometrische Tabellen

auf folgender Seite.

Grad	Sinus						Grad
	0'	10'	20'	30'	40'	50'	
0	0,00000	0,00291	0,00582	0,00873	0,01164	0,01454	89
1	0,01745	0,02036	0,02327	0,02618	0,02908	0,03199	88
2	0,03490	0,03781	0,04071	0,04362	0,04653	0,04943	87
3	0,05234	0,05524	0,05814	0,06105	0,06395	0,06685	86
4	0,06976	0,07266	0,07556	0,07846	0,08136	0,08426	85
5	0,08716	0,09005	0,09295	0,09585	0,09874	0,10164	84
6	0,10453	0,10742	0,11031	0,11320	0,11609	0,11898	83
7	0,12187	0,12476	0,12764	0,13053	0,13341	0,13629	82
8	0,13917	0,14205	0,14493	0,14781	0,15069	0,15356	81
9	0,15643	0,15931	0,16218	0,16505	0,16792	0,17078	80
10	0,17365	0,17651	0,17937	0,18224	0,18509	0,18795	79
11	0,19081	0,19366	0,19652	0,19937	0,20222	0,20507	78
12	0,20791	0,21076	0,21360	0,21644	0,21928	0,22212	77
13	0,22495	0,22778	0,23062	0,23345	0,23627	0,23910	76
14	0,24192	0,24474	0,24756	0,25038	0,25320	0,25601	75
15	0,25882	0,26163	0,26443	0,26724	0,27004	0,27284	74
16	0,27564	0,27843	0,28123	0,28402	0,28680	0,28959	73
17	0,29237	0,29515	0,29793	0,30071	0,30348	0,30625	72
18	0,30902	0,31178	0,31454	0,31730	0,32006	0,32282	71
19	0,32557	0,32832	0,33106	0,33381	0,33655	0,33929	70
20	0,34202	0,34475	0,34748	0,35021	0,35293	0,35565	69
21	0,35837	0,36108	0,36379	0,36650	0,36921	0,37191	68
22	0,37461	0,37730	0,37999	0,38268	0,38537	0,38805	67
23	0,39073	0,39341	0,39608	0,39875	0,40141	0,40408	66
24	0,40674	0,40939	0,41204	0,41469	0,41734	0,41998	65
25	0,42262	0,42525	0,42788	0,43051	0,43313	0,43575	64
26	0,43837	0,44098	0,44359	0,44620	0,44880	0,45140	63
27	0,45399	0,45658	0,45917	0,46175	0,46433	0,46690	62
28	0,46947	0,47204	0,47460	0,47716	0,47971	0,48226	61
29	0,48481	0,48735	0,48989	0,49242	0,49495	0,49748	60
30	0,50000	0,50252	0,50503	0,50754	0,51004	0,51254	59
31	0,51504	0,51753	0,52002	0,52250	0,52498	0,52745	58
32	0,52992	0,53238	0,53484	0,53730	0,53975	0,54220	57
33	0,54464	0,54708	0,54951	0,55194	0,55436	0,55678	56
34	0,55919	0,56160	0,56401	0,56641	0,56880	0,57119	55
35	0,57358	0,57596	0,57833	0,58070	0,58307	0,58543	54
36	0,58779	0,59014	0,59248	0,59482	0,59716	0,59949	53
37	0,60182	0,60414	0,60645	0,60876	0,61107	0,61337	52
38	0,61566	0,61795	0,62024	0,62251	0,62479	0,62706	51
39	0,62932	0,63158	0,63383	0,63608	0,63832	0,64056	50
40	0,64279	0,64501	0,64723	0,64945	0,65166	0,65386	49
41	0,65606	0,65825	0,66044	0,66262	0,66480	0,66697	48
42	0,66913	0,67129	0,67344	0,67559	0,67773	0,67987	47
43	0,68200	0,68412	0,68624	0,68835	0,69046	0,69256	46
44	0,69466	0,69675	0,69883	0,70091	0,70298	0,70505	45
45	0,70711						44
	60'	50'	40'	30'	20'	10'	Grad

Cosinus

Grad	Cosinus						
	0'	10'	20'	30'	40'	50'	
0	1,00000	1,00000	0,99998	0,99996	0,99993	0,99989	89
1	0,99985	0,99979	0,99973	0,99966	0,99958	0,99949	88
2	0,99939	0,99929	0,99917	0,99905	0,99892	0,99878	87
3	0,99863	0,99847	0,99831	0,99813	0,99795	0,99776	86
4	0,99756	0,99736	0,99714	0,99692	0,99668	0,99644	85
5	0,99619	0,99594	0,99567	0,99540	0,99511	0,99482	84
6	0,99452	0,99421	0,99390	0,99357	0,99324	0,99290	83
7	0,99255	0,99219	0,99182	0,99144	0,99106	0,99067	82
8	0,99027	0,98986	0,98944	0,98902	0,98858	0,98814	81
9	0,98769	0,98723	0,98676	0,98629	0,98580	0,98531	80
10	0,98481	0,98430	0,98378	0,98325	0,98272	0,98218	79
11	0,98163	0,98107	0,98050	0,97992	0,97934	0,97875	78
12	0,97815	0,97754	0,97692	0,97630	0,97566	0,97502	77
13	0,97437	0,97371	0,97304	0,97237	0,97169	0,97100	76
14	0,97030	0,96959	0,96887	0,96815	0,96742	0,96667	75
15	0,96593	0,96517	0,96440	0,96363	0,96285	0,96206	74
16	0,96126	0,96046	0,95964	0,95882	0,95799	0,95715	73
17	0,95630	0,95545	0,95459	0,95372	0,95284	0,95195	72
18	0,95106	0,95015	0,94924	0,94832	0,94740	0,94646	71
19	0,94552	0,94457	0,94361	0,94264	0,94167	0,94068	70
20	0,93969	0,93869	0,93769	0,93667	0,93565	0,93462	69
21	0,93358	0,93253	0,93148	0,93042	0,92935	0,92827	68
22	0,92718	0,92609	0,92499	0,92388	0,92276	0,92164	67
23	0,92050	0,91936	0,91822	0,91706	0,91590	0,91472	66
24	0,91355	0,91236	0,91116	0,90996	0,90875	0,90753	65
25	0,90631	0,90507	0,90383	0,90259	0,90133	0,90007	64
26	0,89879	0,89752	0,89623	0,89493	0,89363	0,89232	63
27	0,89101	0,88968	0,88835	0,88701	0,88566	0,88431	62
28	0,88295	0,88158	0,88020	0,87882	0,87743	0,87603	61
29	0,87462	0,87321	0,87178	0,87036	0,86892	0,86748	60
30	0,86603	0,86457	0,86310	0,86163	0,86015	0,85866	59
31	0,85717	0,85567	0,85416	0,85264	0,85112	0,84959	58
32	0,84805	0,84650	0,84495	0,84339	0,84182	0,84025	57
33	0,83867	0,83708	0,83549	0,83389	0,83228	0,83066	56
34	0,82904	0,82741	0,82577	0,82413	0,82248	0,82082	55
35	0,81915	0,81748	0,81580	0,81412	0,81242	0,81072	54
36	0,80902	0,80730	0,80558	0,80386	0,80212	0,80038	53
37	0,79864	0,79688	0,79512	0,79335	0,79158	0,78980	52
38	0,78801	0,78622	0,78442	0,78261	0,78079	0,77897	51
39	0,77715	0,77531	0,77347	0,77162	0,76977	0,76791	50
40	0,76604	0,76417	0,76229	0,76041	0,75851	0,75661	49
41	0,75471	0,75280	0,75088	0,74896	0,74703	0,74509	48
42	0,74314	0,74120	0,73924	0,73728	0,73531	0,73333	47
43	0,73135	0,72937	0,72737	0,72537	0,72337	0,72136	46
44	0,71934	0,71732	0,71529	0,71325	0,71121	0,70916	45
45	0,70711						44
	60'	50'	40'	30'	20'	10'	Grad

Sinus

Grad	Tangens						Grad
	0'	10'	20'	30'	40'	50'	
0	0,00000	0,00291	0,00582	0,00873	0,01164	0,01455	89
1	0,01746	0,02036	0,02328	0,02619	0,02910	0,03201	88
2	0,03492	0,03783	0,04075	0,04366	0,04658	0,04949	87
3	0,05241	0,05533	0,05824	0,06116	0,06408	0,06700	86
4	0,06993	0,07285	0,07578	0,07870	0,08163	0,08456	85
5	0,08749	0,09042	0,09335	0,09629	0,09923	0,10216	84
6	0,10510	0,10805	0,11099	0,11394	0,11688	0,11983	83
7	0,12278	0,12574	0,12869	0,13165	0,13461	0,13758	82
8	0,14054	0,14351	0,14648	0,14945	0,15243	0,15540	81
9	0,15838	0,16137	0,16435	0,16734	0,17033	0,17333	80
10	0,17633	0,17933	0,18233	0,18534	0,18835	0,19136	79
11	0,19438	0,19740	0,20042	0,20345	0,20648	0,20952	78
12	0,21256	0,21560	0,21864	0,22169	0,22475	0,22781	77
13	0,23087	0,23393	0,23700	0,24008	0,24316	0,24624	76
14	0,24933	0,25242	0,25552	0,25862	0,26172	0,26483	75
15	0,26795	0,27107	0,27419	0,27732	0,28046	0,28360	74
16	0,28675	0,28990	0,29305	0,29621	0,29938	0,30255	73
17	0,30573	0,30891	0,31210	0,31530	0,31850	0,32171	72
18	0,32492	0,32814	0,33136	0,33460	0,33783	0,34108	71
19	0,34433	0,34758	0,35085	0,35412	0,35740	0,36068	70
20	0,36397	0,36727	0,37057	0,37388	0,37720	0,38053	69
21	0,38386	0,38721	0,39055	0,39391	0,39727	0,40065	68
22	0,40403	0,40741	0,41081	0,41421	0,41763	0,42105	67
23	0,42447	0,42791	0,43136	0,43481	0,43828	0,44175	66
24	0,44523	0,44872	0,45222	0,45573	0,45924	0,46277	65
25	0,46631	0,46985	0,47341	0,47698	0,48055	0,48414	64
26	0,48773	0,49134	0,49495	0,49858	0,50222	0,50587	63
27	0,50953	0,51319	0,51688	0,52057	0,52427	0,52798	62
28	0,53171	0,53545	0,53920	0,54296	0,54673	0,55051	61
29	0,55431	0,55812	0,56194	0,56577	0,56962	0,57348	60
30	0,57735	0,58124	0,58513	0,58905	0,59297	0,59691	59
31	0,60086	0,60483	0,60881	0,61280	0,61681	0,62083	58
32	0,62487	0,62892	0,63299	0,63707	0,64117	0,64528	57
33	0,64941	0,65355	0,65771	0,66189	0,66608	0,67028	56
34	0,67451	0,67875	0,68301	0,68728	0,69157	0,69588	55
35	0,70021	0,70455	0,70891	0,71329	0,71769	0,72211	54
36	0,72654	0,73100	0,73547	0,73996	0,74447	0,74900	53
37	0,75355	0,75812	0,76272	0,76733	0,77196	0,77661	52
38	0,78129	0,78598	0,79070	0,79544	0,80020	0,80498	51
39	0,80978	0,81461	0,81946	0,82434	0,82923	0,83415	50
40	0,83910	0,84407	0,84906	0,85408	0,85912	0,86419	49
41	0,86929	0,87441	0,87955	0,88473	0,88992	0,89515	48
42	0,90040	0,90569	0,91099	0,91633	0,92170	0,92709	47
43	0,93252	0,93797	0,94345	0,94896	0,95451	0,96008	46
44	0,96569	0,97133	0,97700	0,98270	0,98843	0,99420	45
45	1,00000						44
	60'	50'	40'	30'	20'	10'	Grad

Cotangens

Grad	Cotangens						Grad
	0'	10'	20'	30'	40'	50'	
0	∞	343,77371	171,88540	114,58865	85,93979	68,75009	89
1	57,28996	49,10388	42,96408	38,18846	34,36777	31,24158	88
2	28,63625	26,43160	24,54176	22,90377	21,47040	20,20555	87
3	19,08114	18,07498	17,16934	16,34986	15,60478	14,92442	86
4	14,30067	13,72674	13,19688	12,70621	12,25051	11,82617	85
5	11,43005	11,05943	10,71191	10,38540	10,07803	9,78817	84
6	9,51436	9,25530	9,00983	8,77689	8,55555	8,34496	83
7	8,14435	7,95302	7,77035	7,59575	7,42871	7,26873	82
8	7,11537	6,96823	6,82694	6,69116	6,56055	6,43484	81
9	6,31375	6,19703	6,08444	5,97576	5,87080	5,76937	80
10	5,67128	5,57638	5,48451	5,39552	5,30928	5,22566	79
11	5,14455	5,06584	4,98940	4,91516	4,84300	4,77286	78
12	4,70463	4,63825	4,57363	4,51071	4,44942	4,38969	77
13	4,33148	4,27471	4,21933	4,16530	4,11256	4,06107	76
14	4,01078	3,96165	3,91364	3,86671	3,82083	3,77595	75
15	3,73205	3,68909	3,64705	3,60588	3,56557	3,52609	74
16	3,48741	3,44951	3,41236	3,37594	3,34023	3,30521	73
17	3,27085	3,23714	3,20406	3,17159	3,13972	3,10842	72
18	3,07768	3,04749	3,01783	2,98868	2,96004	2,93189	71
19	2,90421	2,87700	2,85023	2,82391	2,79802	2,77254	70
20	2,74748	2,72281	2,69853	2,67462	2,65109	2,62791	69
21	2,60509	2,58261	2,56046	2,53865	2,51715	2,49597	68
22	2,47509	2,45451	2,43422	2,41421	2,39449	2,37504	67
23	2,35585	2,33693	2,31826	2,29984	2,28167	2,26374	66
24	2,24604	2,22857	2,21132	2,19430	2,17749	2,16090	65
25	2,14451	2,12832	2,11233	2,09654	2,08094	2,06553	64
26	2,05030	2,03526	2,02039	2,00569	1,99116	1,97680	63
27	1,96261	1,94858	1,93470	1,92098	1,90741	1,89400	62
28	1,88073	1,86760	1,85462	1,84177	1,82906	1,81649	61
29	1,80405	1,79174	1,77955	1,76749	1,75556	1,74375	60
30	1,73205	1,72047	1,70901	1,69766	1,68643	1,67530	59
31	1,66428	1,65337	1,64256	1,63185	1,62125	1,61074	58
32	1,60033	1,59002	1,57981	1,56969	1,55966	1,54972	57
33	1,53987	1,53010	1,52043	1,51084	1,50133	1,49190	56
34	1,48256	1,47330	1,46411	1,45501	1,44598	1,43703	55
35	1,42815	1,41934	1,41061	1,40195	1,39336	1,38484	54
36	1,37638	1,36800	1,35968	1,35142	1,34323	1,33511	53
37	1,32704	1,31904	1,31110	1,30323	1,29541	1,28764	52
38	1,27994	1,27230	1,26471	1,25717	1,24969	1,24227	51
39	1,23490	1,22758	1,22031	1,21310	1,20593	1,19882	50
40	1,19175	1,18474	1,17777	1,17085	1,16398	1,15715	49
41	1,15037	1,14363	1,13694	1,13029	1,12369	1,11713	48
42	1,11061	1,10414	1,09770	1,09131	1,08496	1,07864	47
43	1,07237	1,06613	1,05994	1,05378	1,04766	1,04158	46
44	1,03553	1,02952	1,02355	1,01761	1,01170	1,00583	45
45	1,00000						44
	60'	50'	40'	30'	20'	10'	Grad

Tangens



40.00

S. 61





WYDZIAŁY POLITECHNICZNE KRAKÓW

Biblioteka Politechniki Krakowskiej



III-306936

Druk. U. J. Zam. 356. 10.000.

Biblioteka Politechniki Krakowskiej



100000300266