



Biblioteka Politechniki Krakowskiej



100000300860

PLATEN

BEHOORENDE BIJ DE

WATERBOUWKUNDE,

DOOR

N. H. HENKET, DR. CH. M. SCHOLS EN J. M. TELDERS,

HOOGLEERAREN AAN DE POLYTECHNISCHE SCHOOL TE DELFT

MET MEDEWERKING VAN

VERSCHILLENDE INGENIEURS.

F. No. 17433

VIERDE DEEL.

Afd. XV^B. Spoorwegen.



'S-GRAVENHAGE, DE GEBROEDERS VAN CLEFF.

G. 37.
35.

xxx
343/1



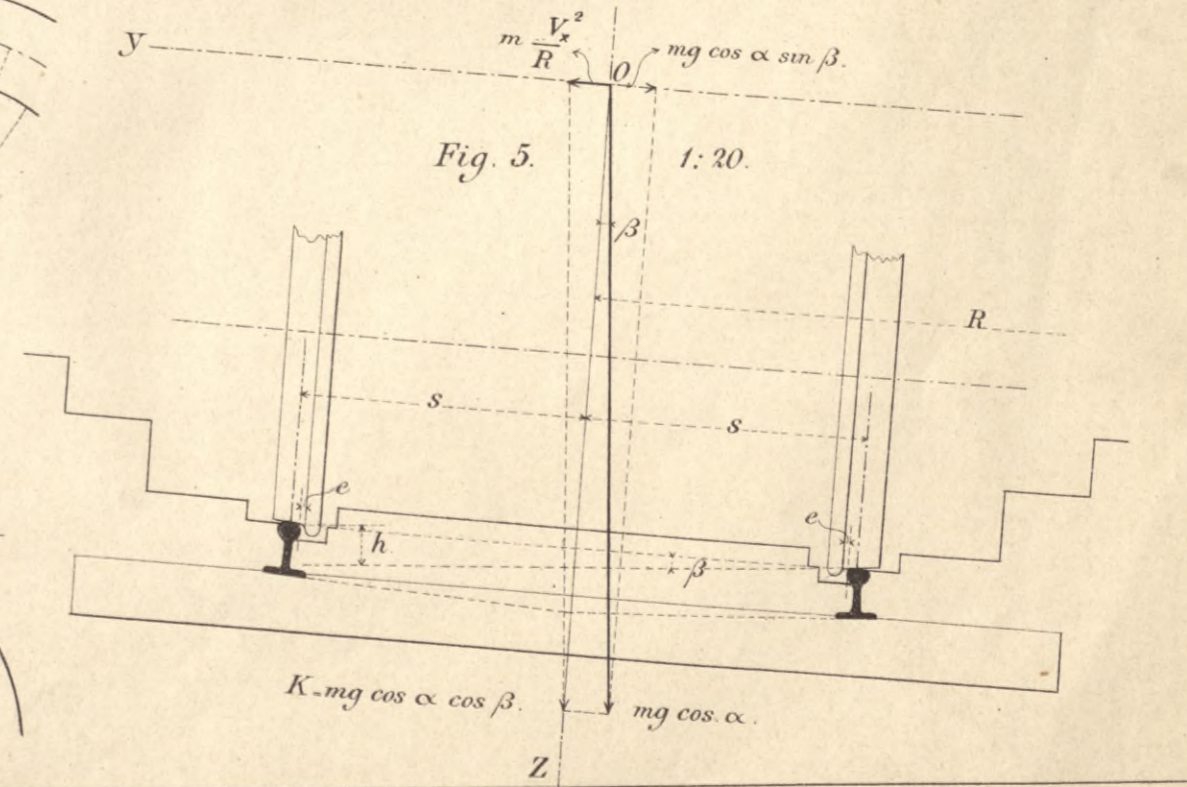
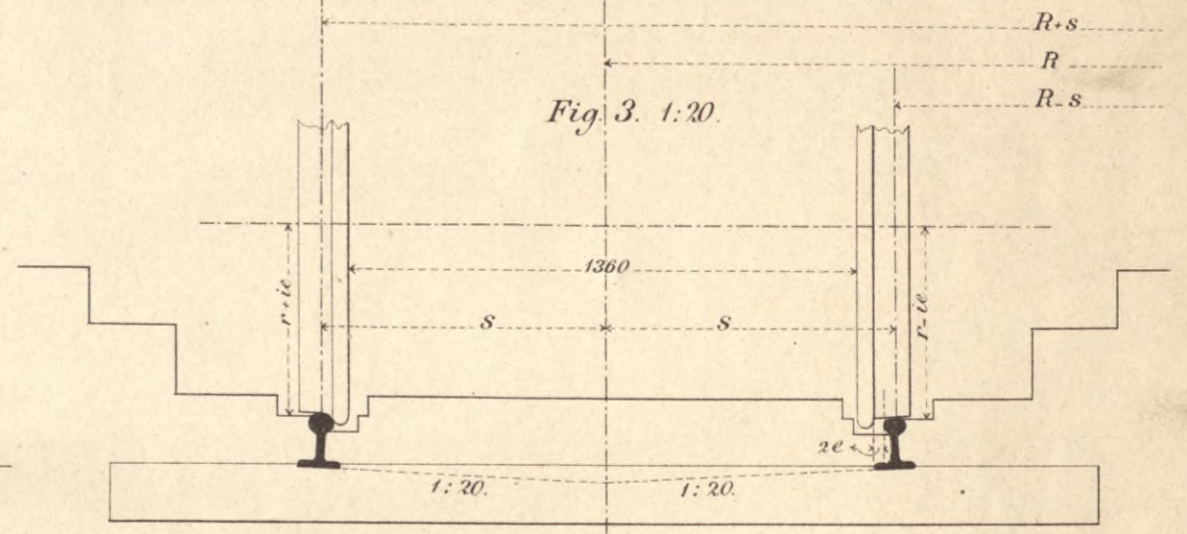
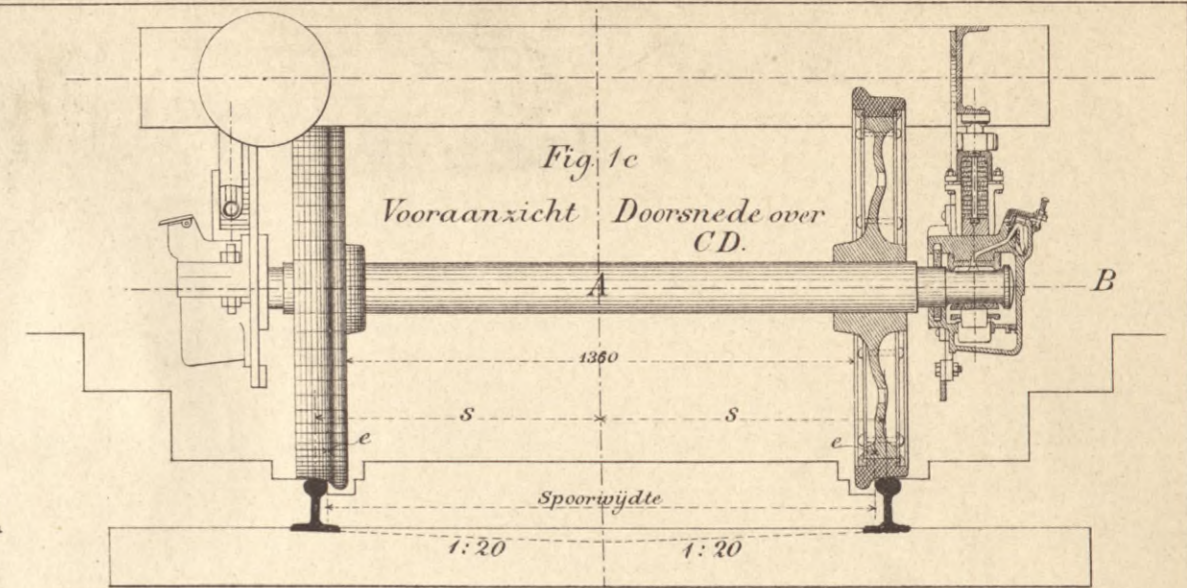
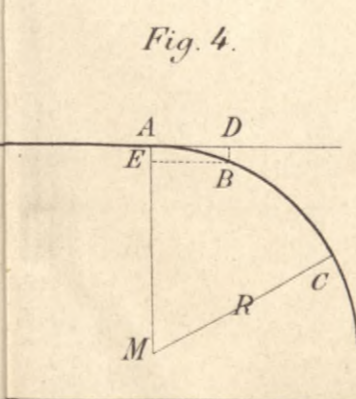
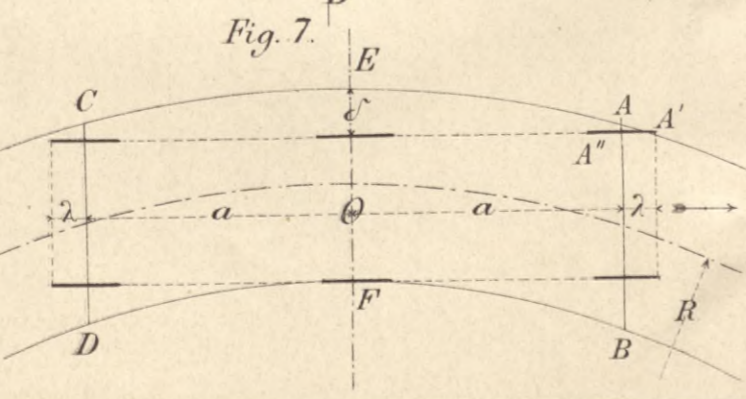
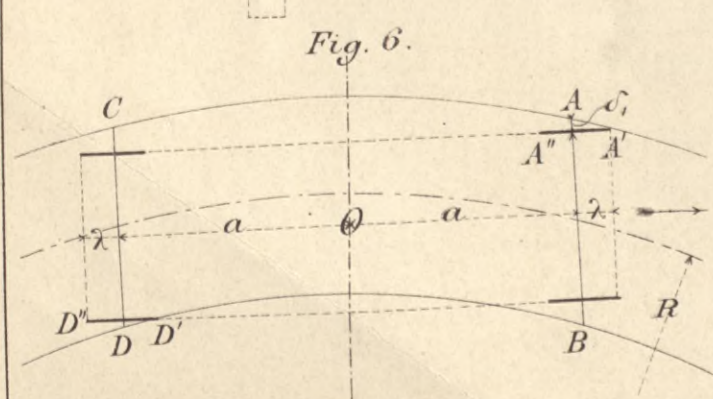
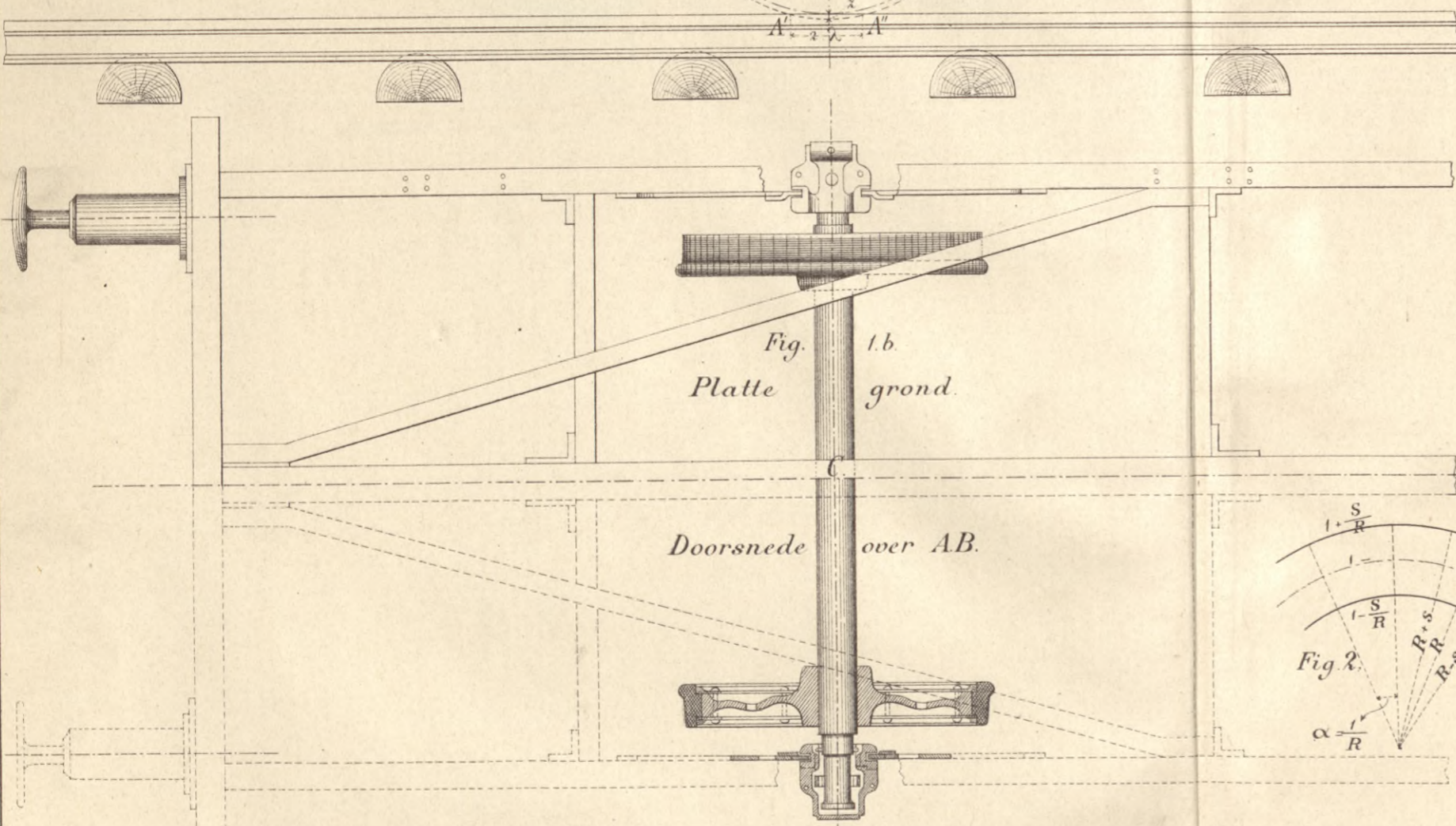
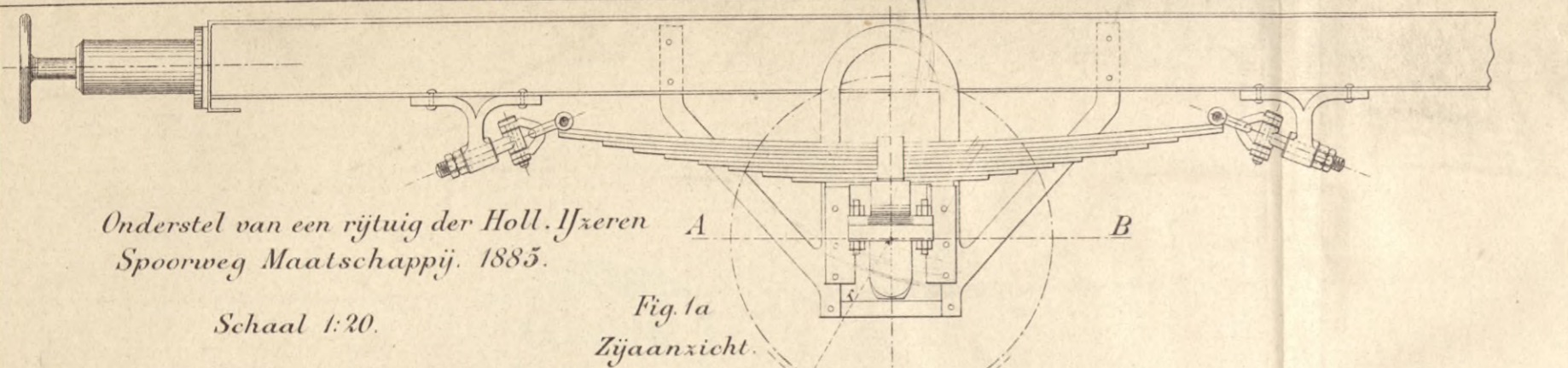
IV - 300961

~~III 18242~~

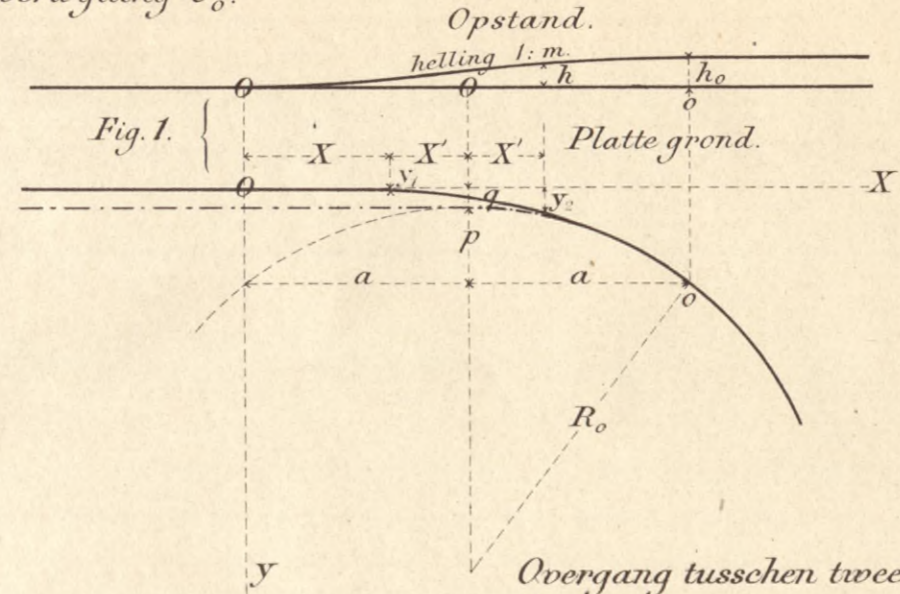
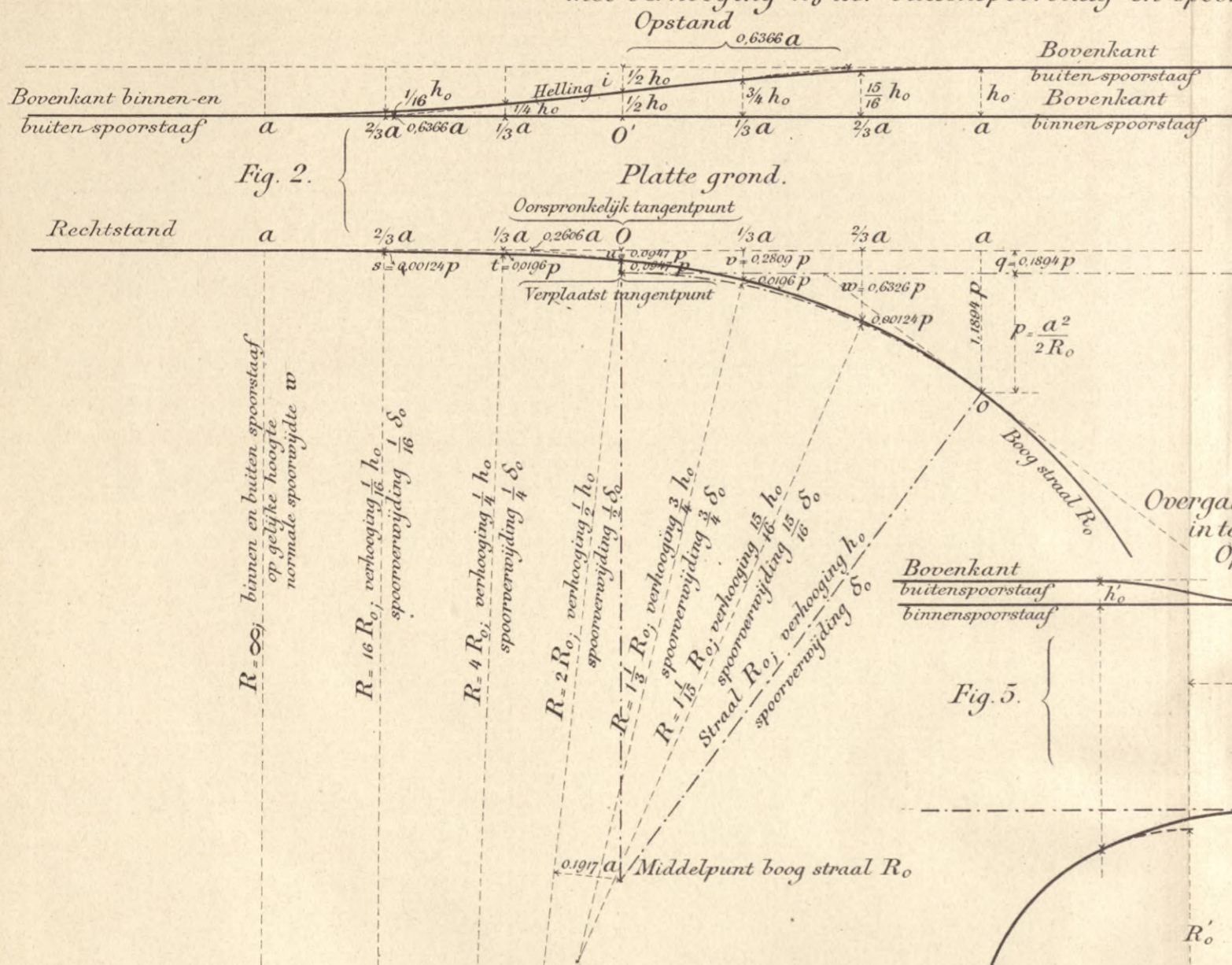
Akc. Nr.

~~1050~~ 52

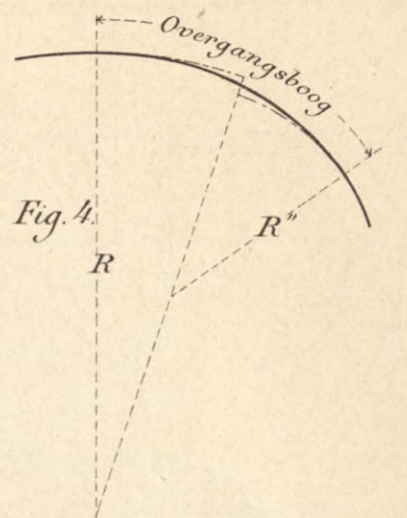
BPK - 0-277 / 2017



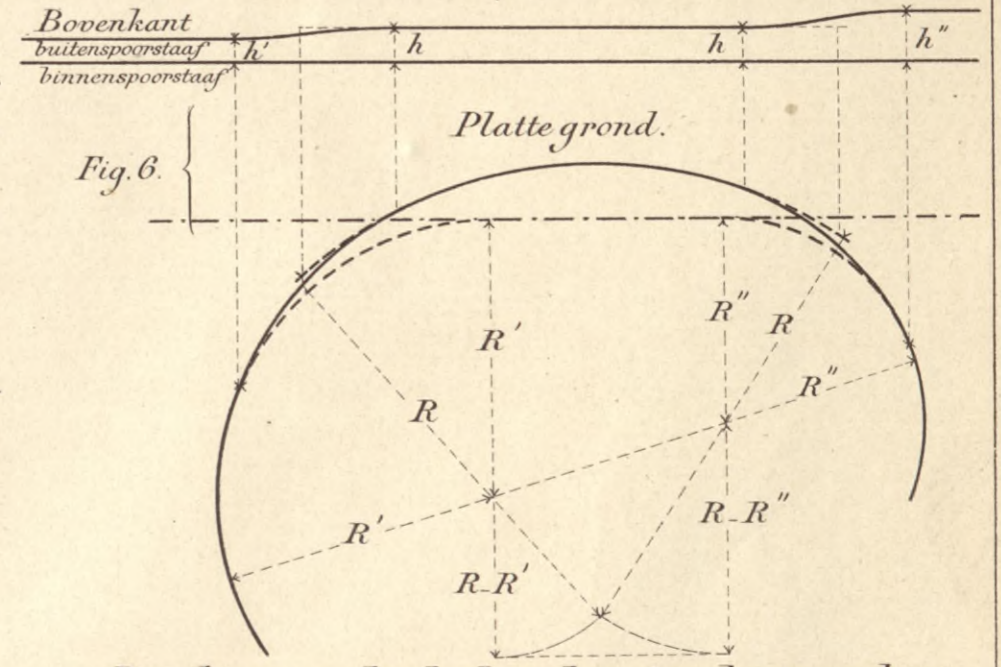
Overgang van een rechtstand in een boog van een straal R_0 , met verhooging h_0 der buitenspoorstaaf en spoorverwijding δ_0 .



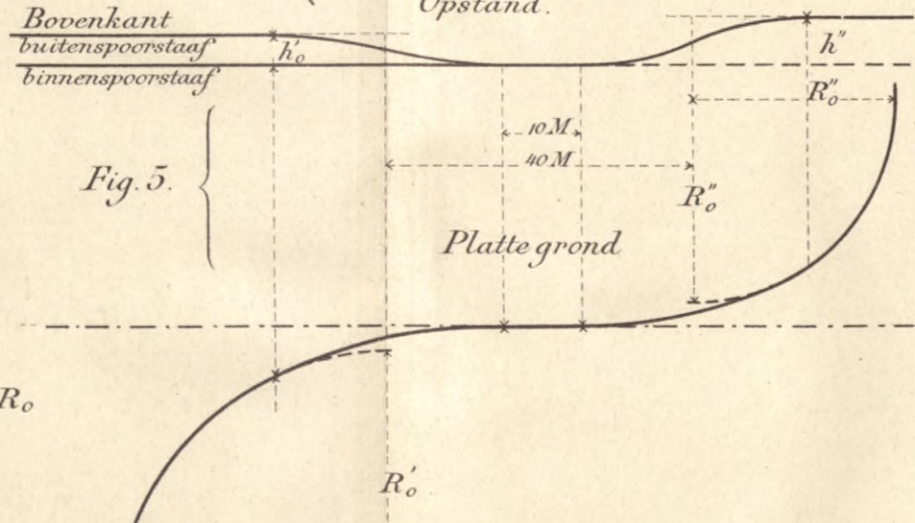
Overgang tusschen bogen van verschillenden straal.



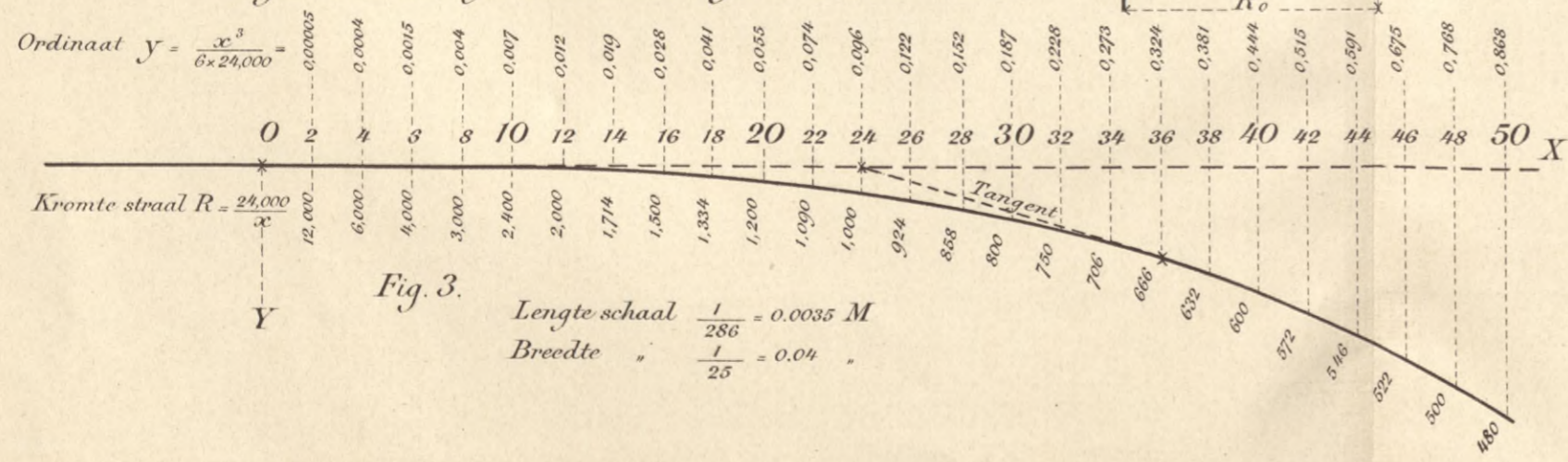
Overgang tusschen twee bogen in dexelfde richting.



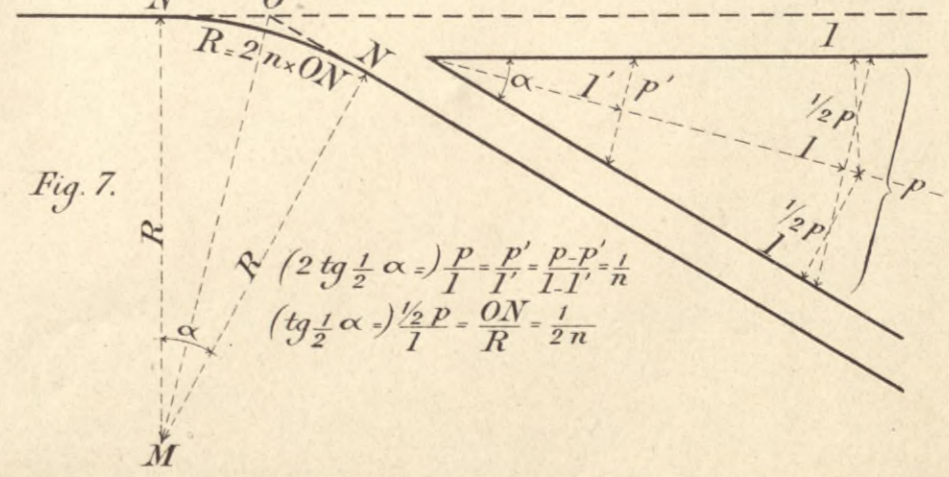
Overgang tusschen twee bogen in tegengestelde richting.

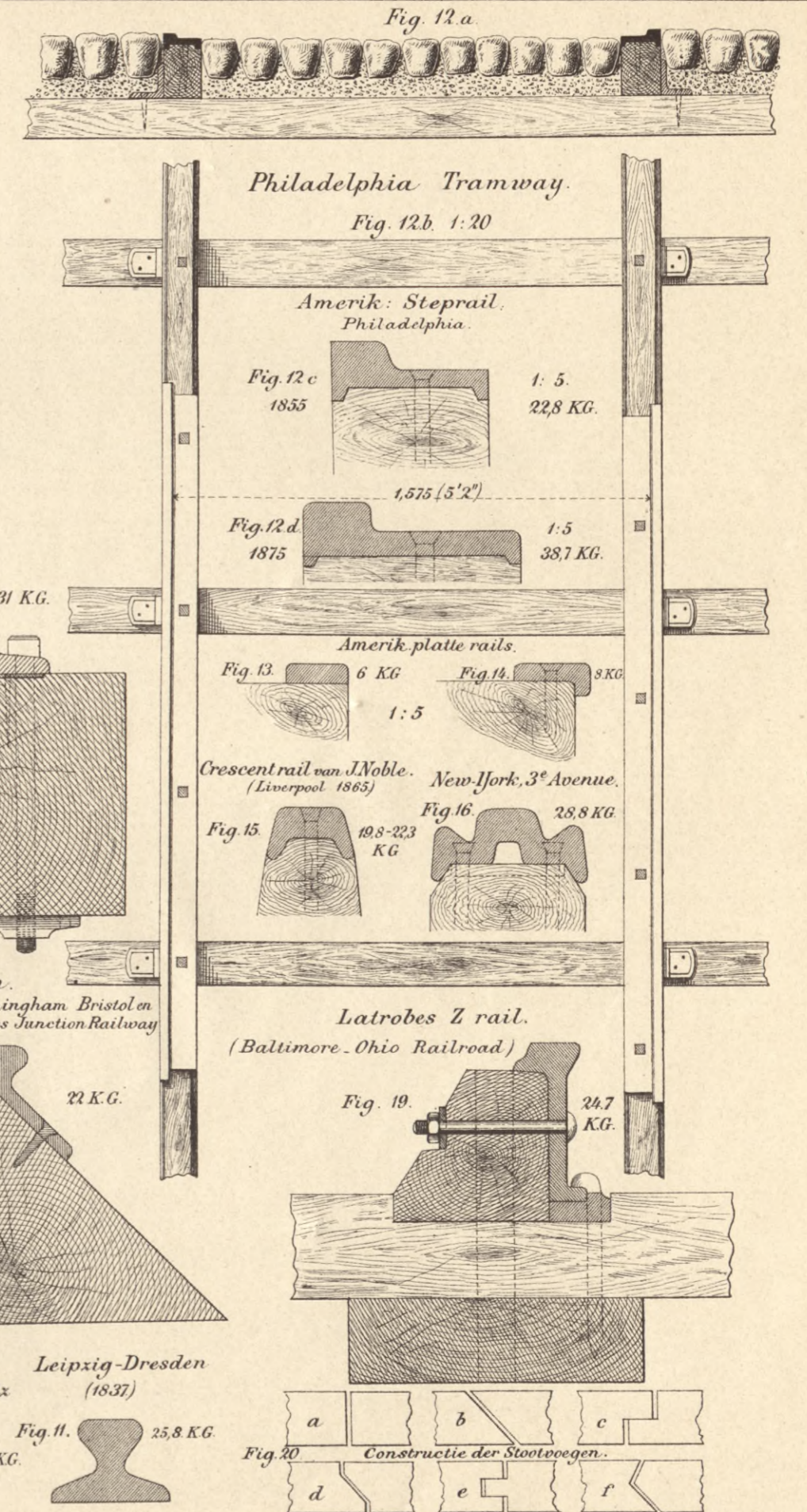
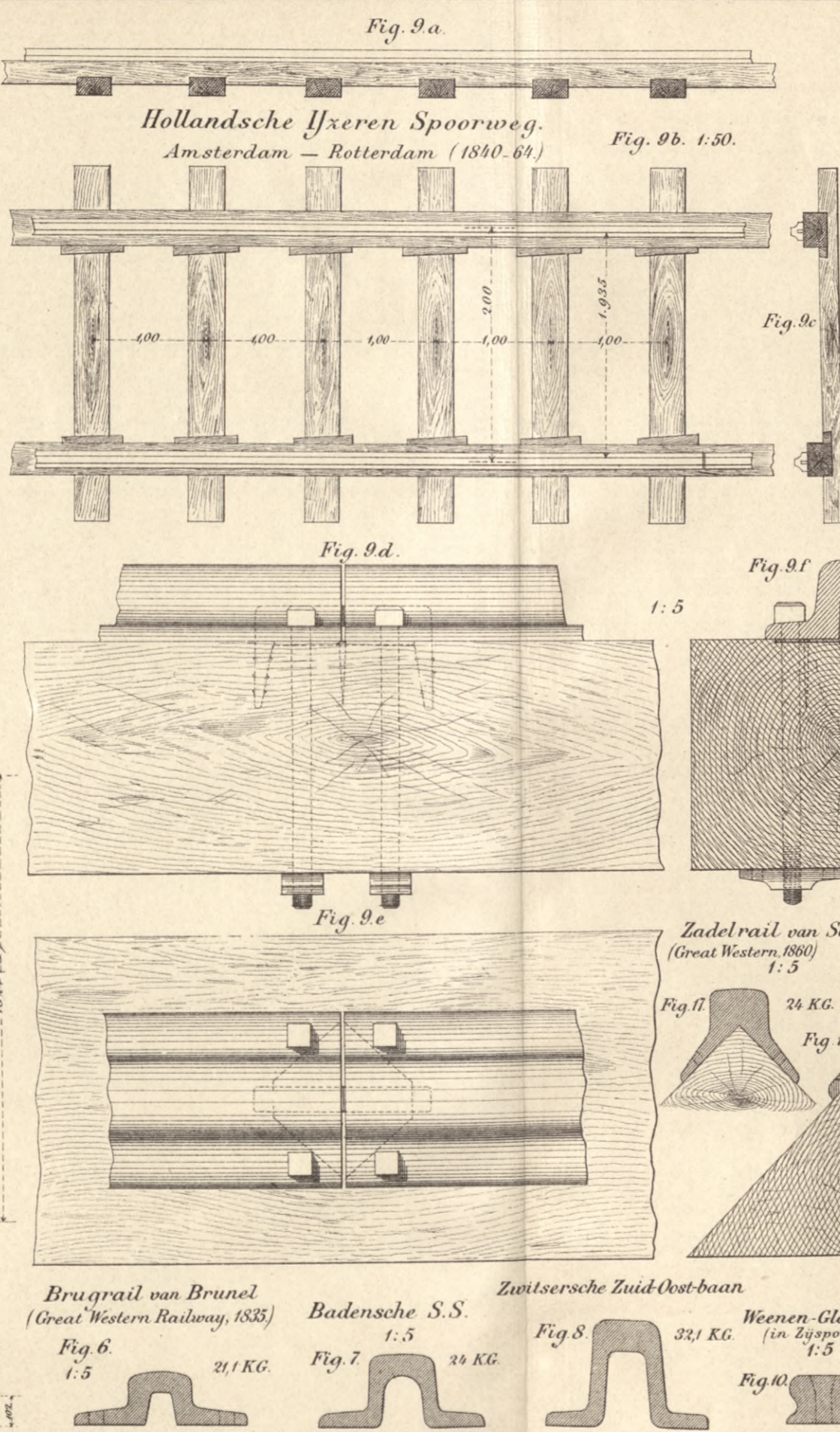
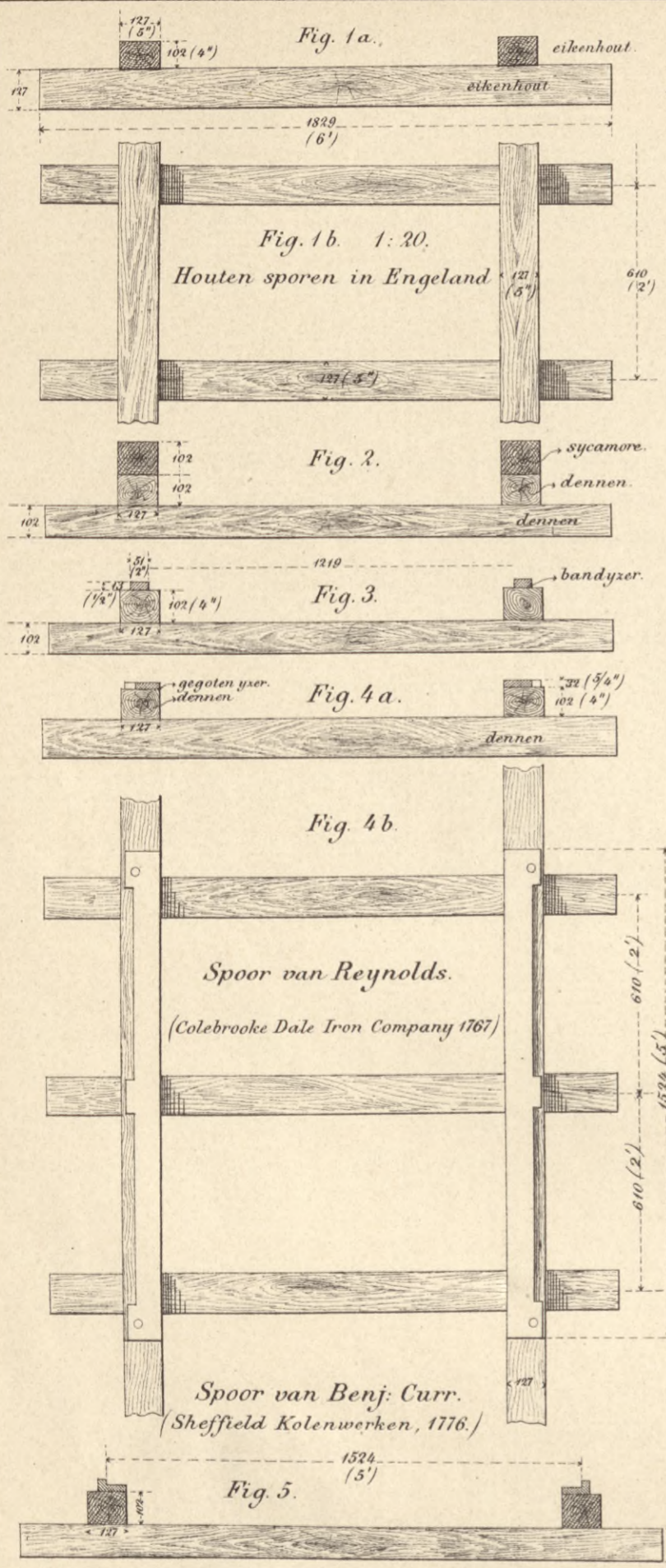


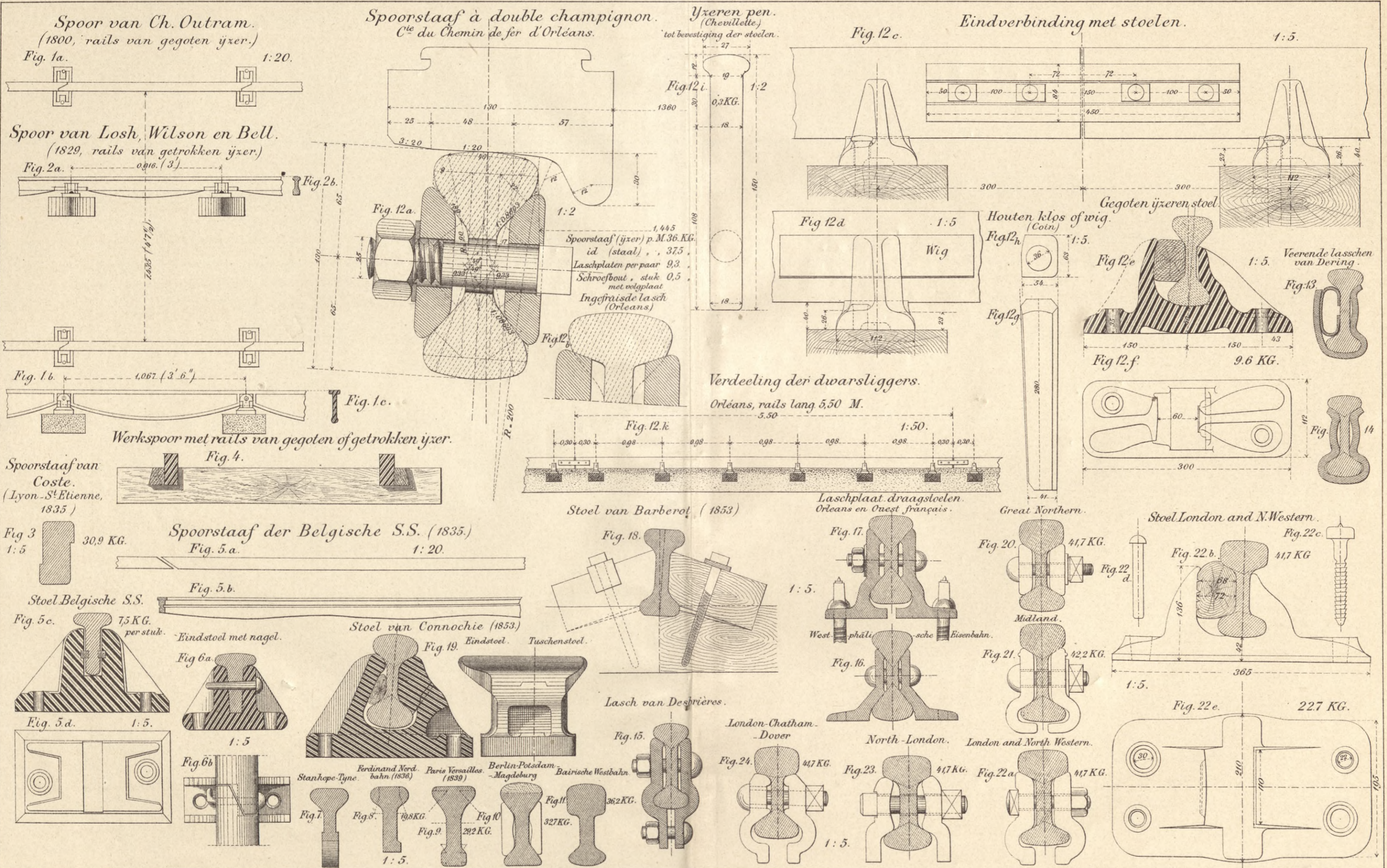
Overgang van een rechtstand in een boog, volgens voorschriften Chemin de fer d'Orléans 1867.

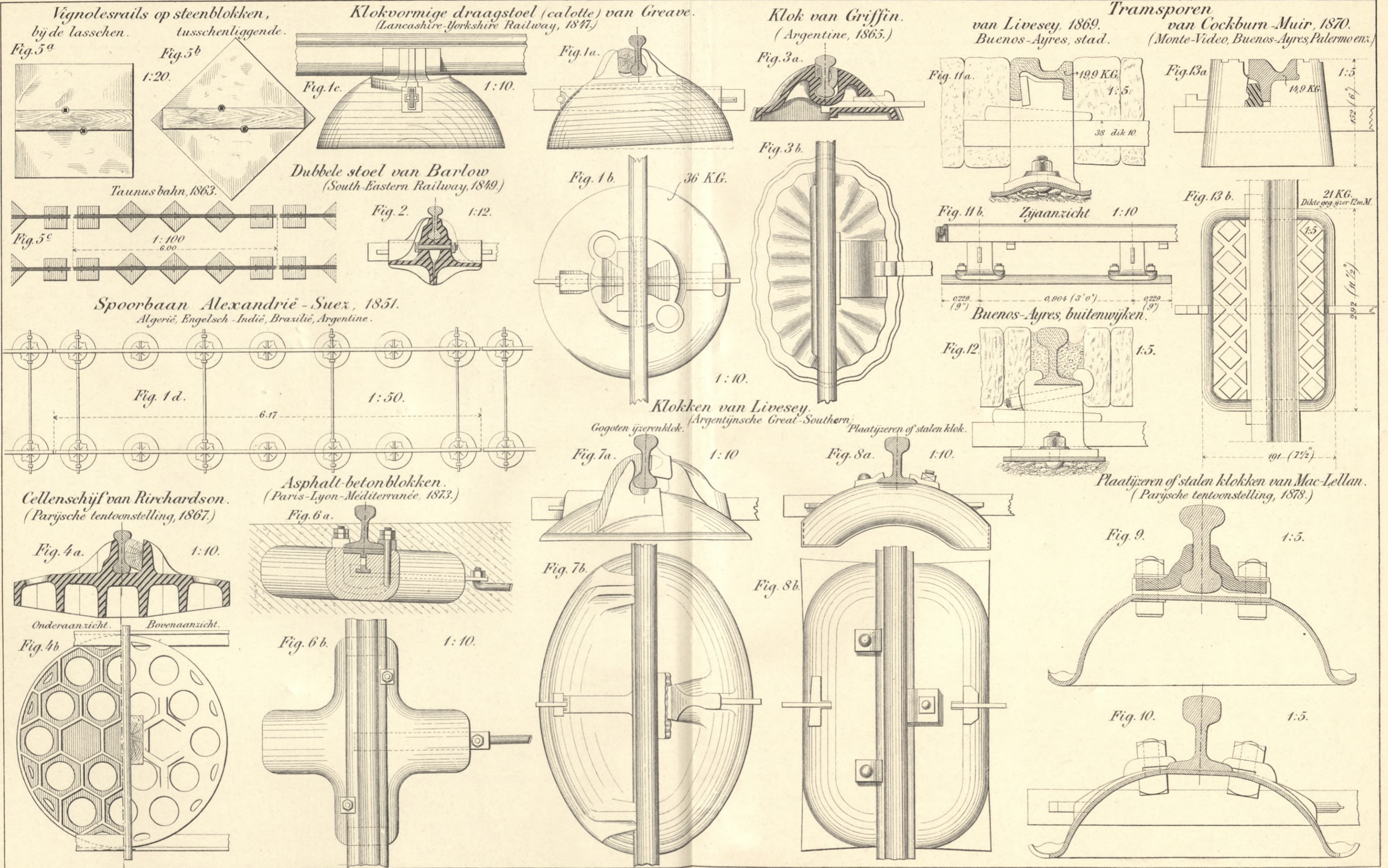


Bepaling van den hoek en den straal van een boog.

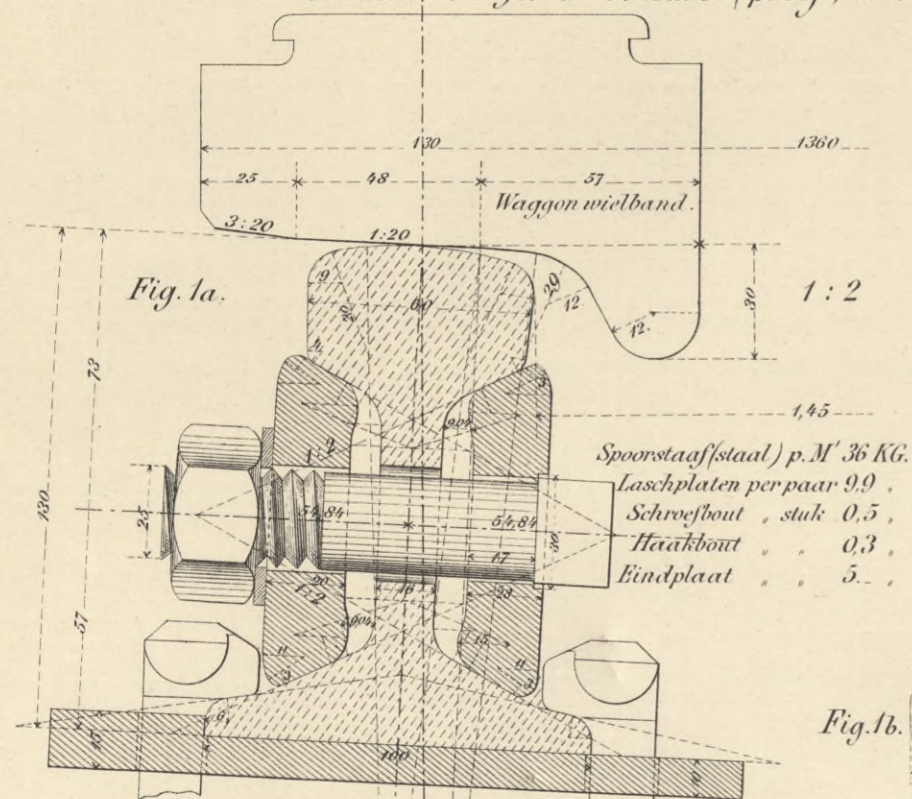




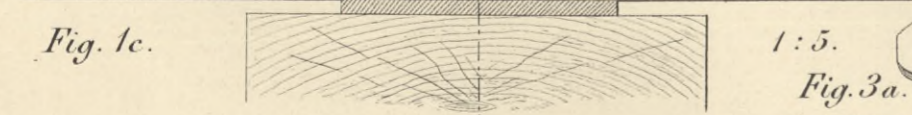
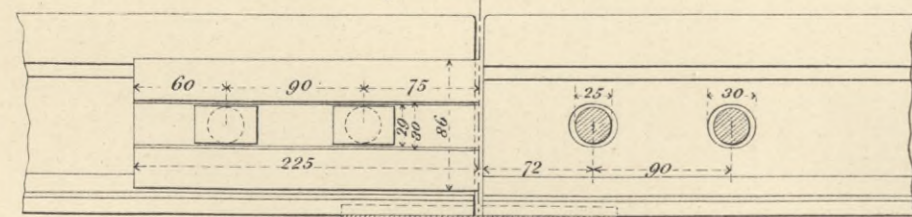




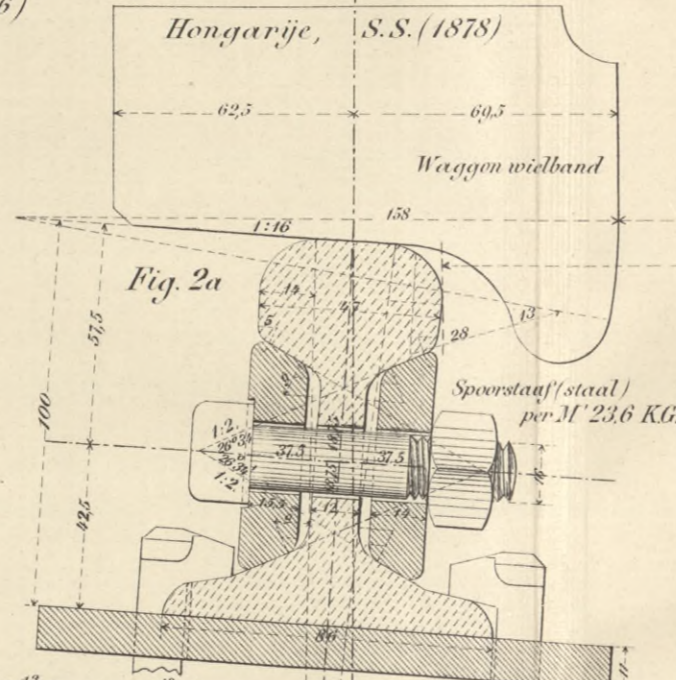
Spoorstaven met eindverbindingen.
Chemin de fer d'Orléans (proef, 1873-76)



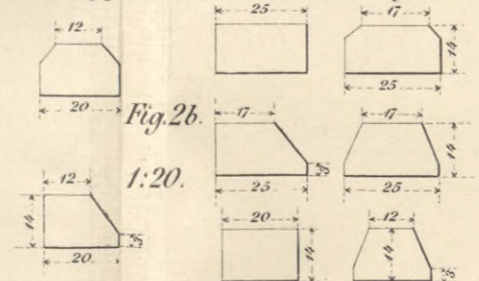
Eindverbinding.
Chemin de fer d'Orléans.



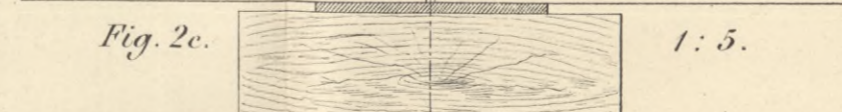
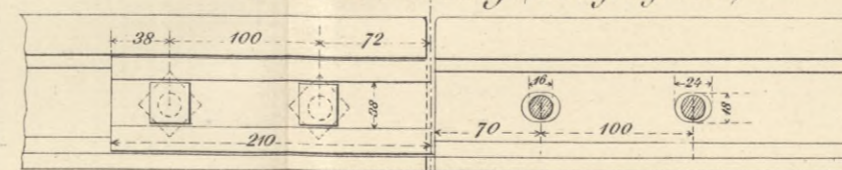
Hongarije, S.S. (1878)



Dwarssliggers. (Hongarije S.S.)
Tusschenliggende. Onder de stootvoegen.

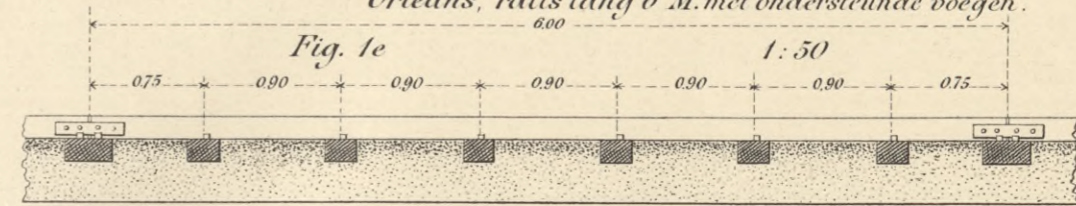


Eindverbinding. (Hongarije S.S.)

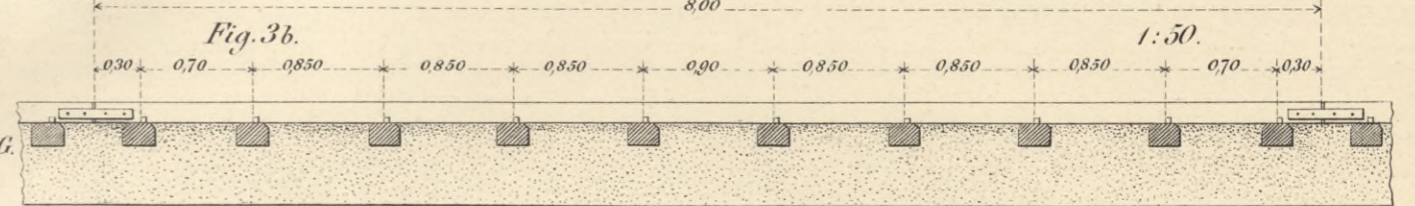


Verdeeling der dwarssliggers.

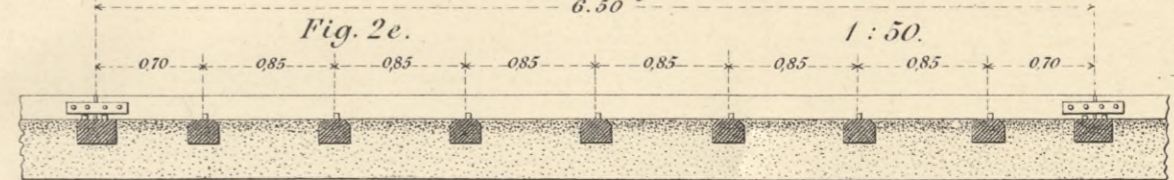
Orléans, rails lang 6 M. met ondersteunde voegen.



P.L.M. rails lang 8 M' met overstekende voegen.



Hongarije, S.S. rails lang 6,50 M. met ondersteunde voegen.



Eikendwarsligger na ± 7 jaar gebruik.

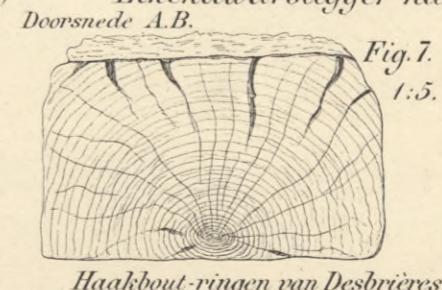
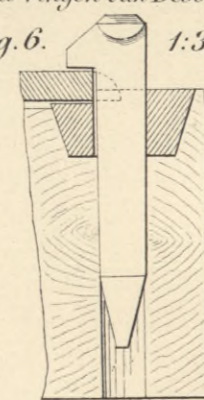
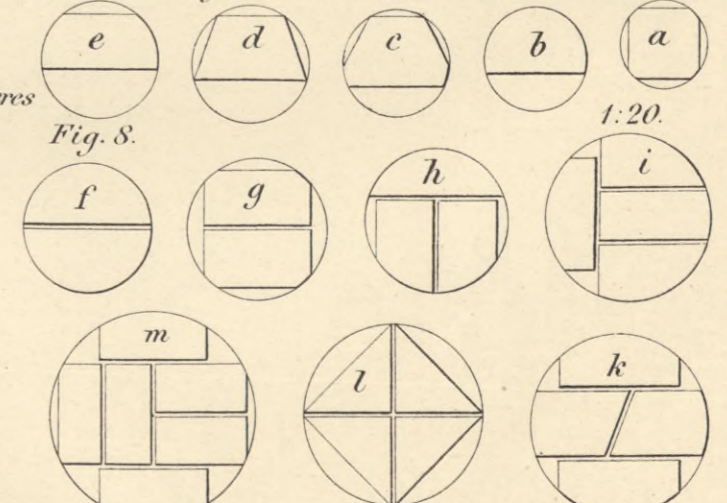


Fig. 6. 1:3.



Verdeeling van dwarssliggers uit boomstammen.

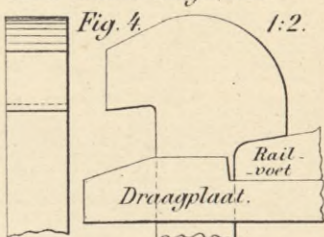


Gebreken van hout.
Vries wind- en hart-scheuren. Losse ringen.

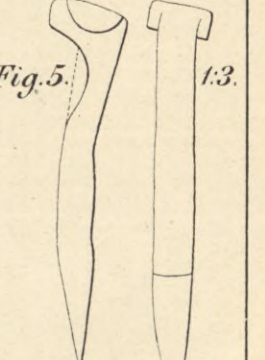


Haakbouthop.

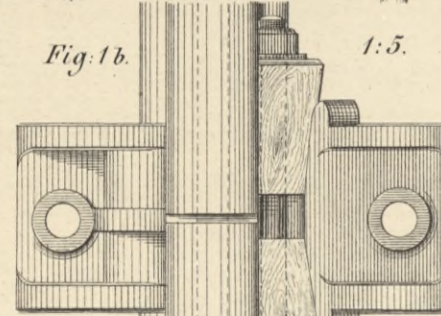
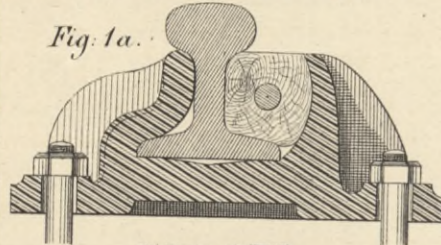
Alta-Italia. Turijn, 1875



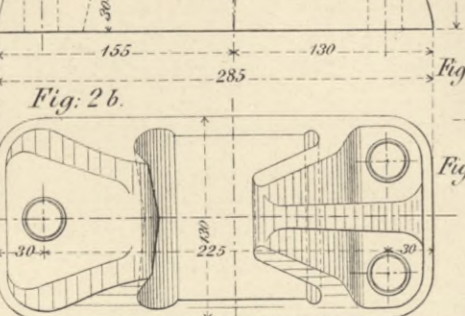
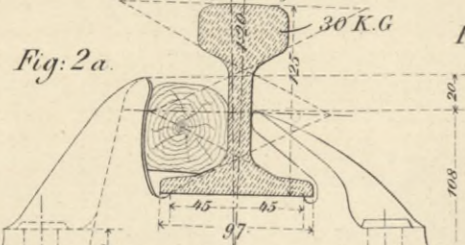
Gebruikte haakbout



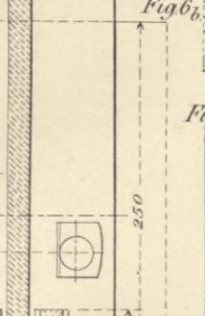
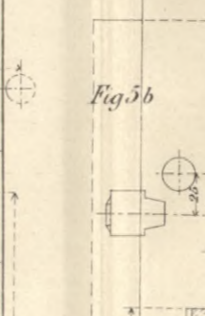
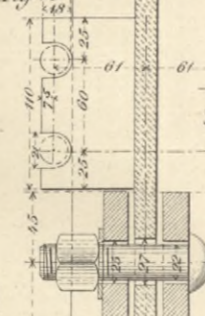
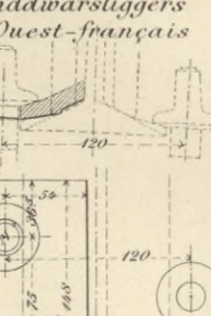
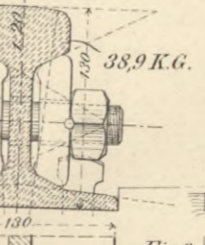
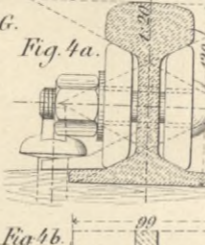
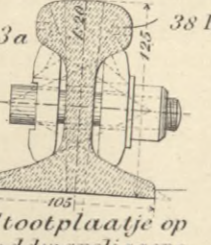
Eindstoel voor Vignolesrails. Saarbrücker Bahn, 1865.



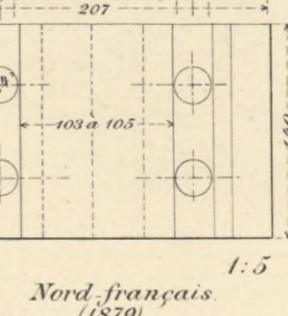
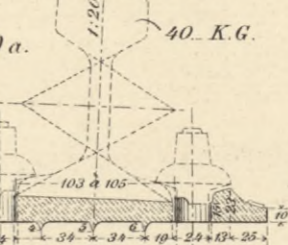
Tussenstoel voor Vignolesrails. Ouest-français.



Rails met eindverbindingen; bevestiging en ondersteuning op de dwarsliggers. Etat-Belge. Est-français. P. M. P. L. M.-A.



Tandplaat. Expt. Mg. S.S.



Geg. ijz. steunklossen. N.H.S.S.

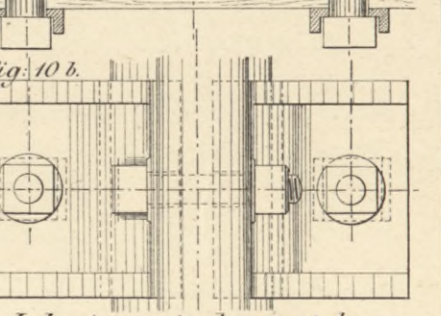
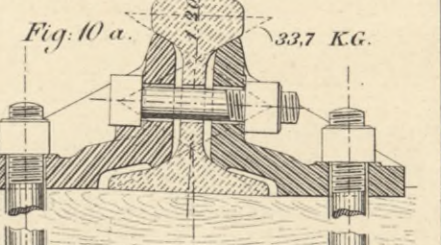
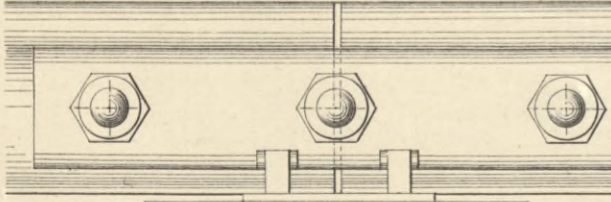
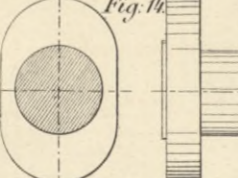


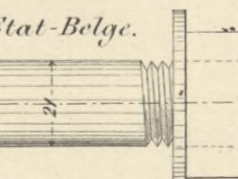
Fig. 13. Eindverbinding met drie bouten.



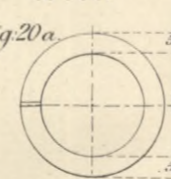
Schlesische Bahn.



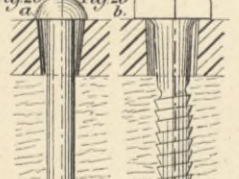
Laschbouten. Etat-Belge.



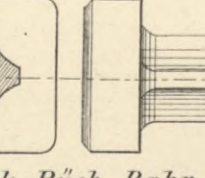
Veerring van Grover



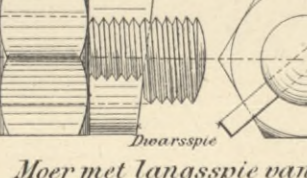
Bevestiging van geg. ijz. stoelen London and N.Western



Parsons bout.



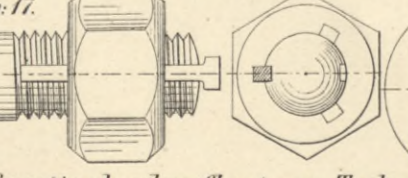
Lübeck-Büch-Bahn



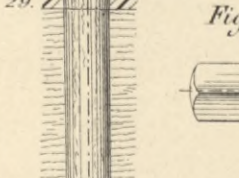
South-Eastern London and Chatham Dover



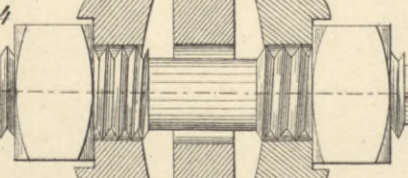
Moer met langspie van Lucas



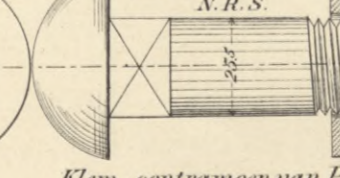
Great-Northern



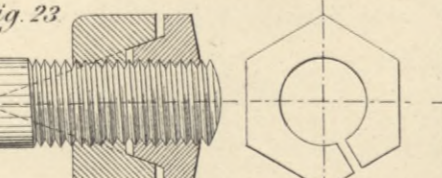
Differentiaal-schroefbout van Tudor



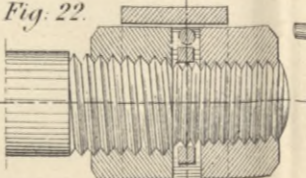
Ibbotsens bout. N.R.S.

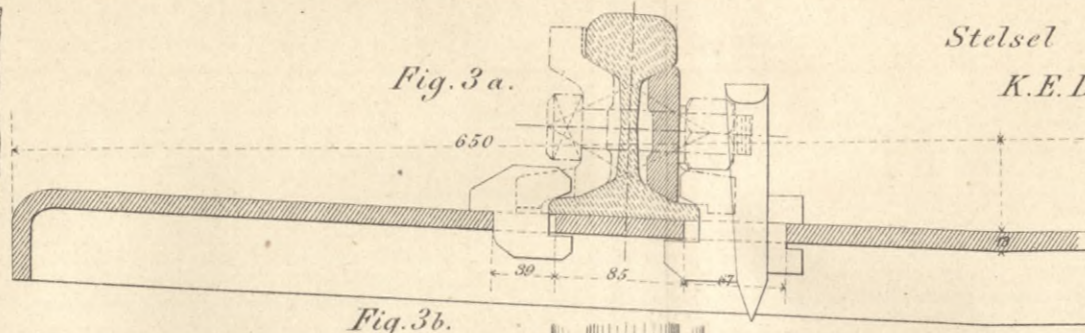
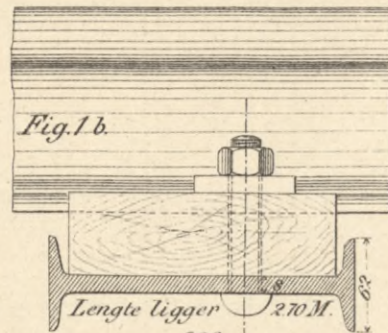
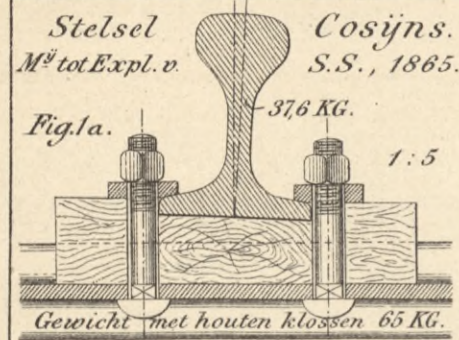


Klem-contramoer van Palliser.

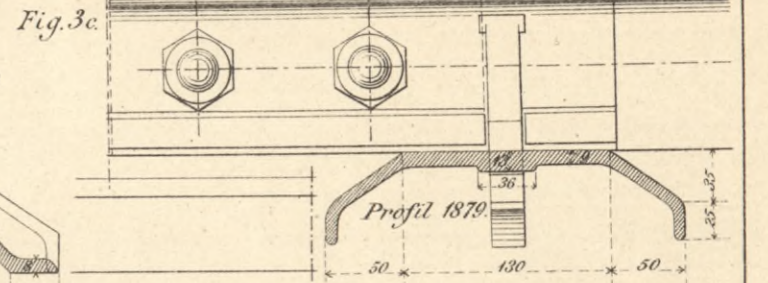
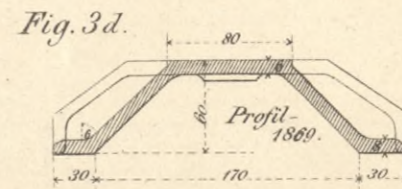


Contraoer van Strauch.

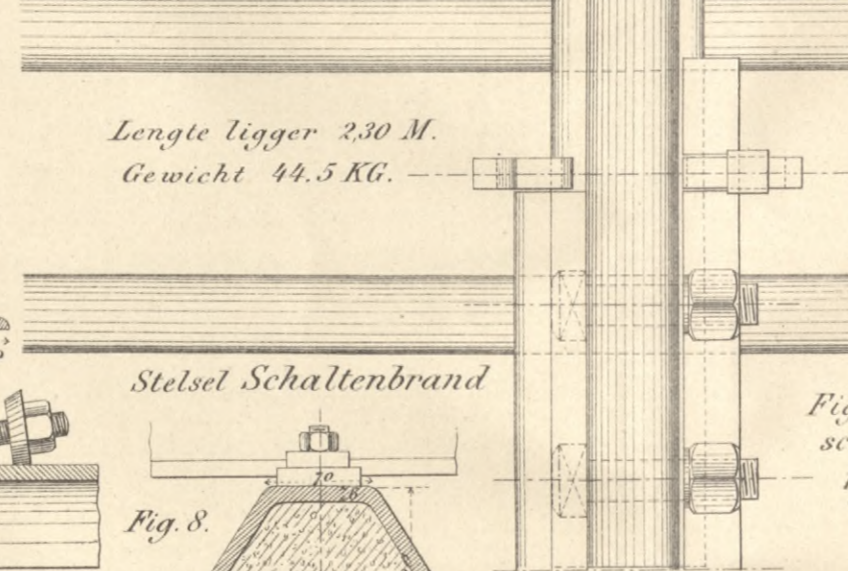
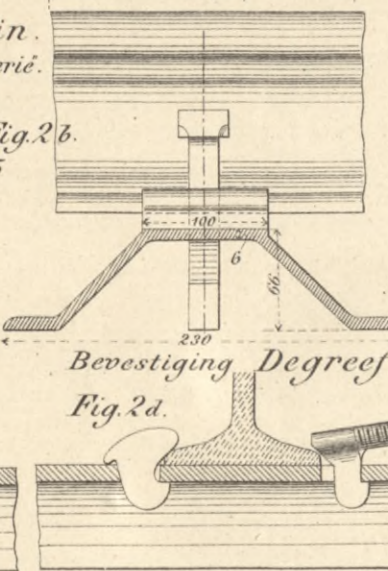
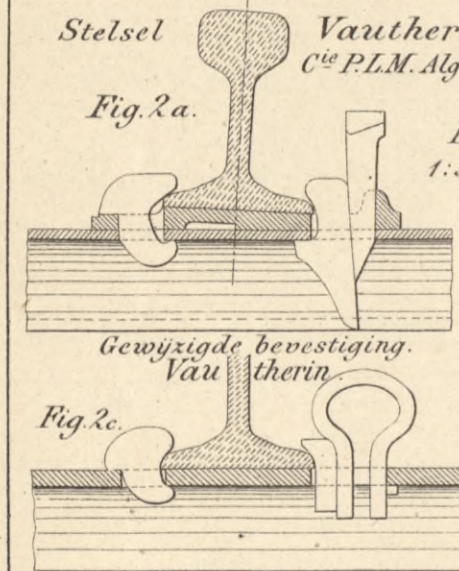




Stelsel Vautherin.
K.E.D. Elberfeld.

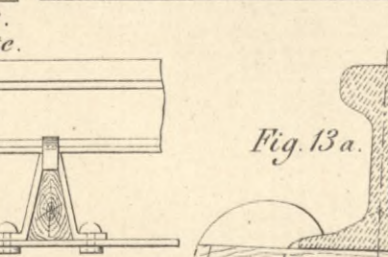
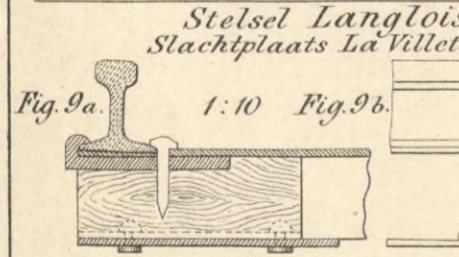


Stelsel Le Crenier. Portugal.



Stelsel Schaltenbrand

Figurenschaal 1:5



Stelsel Guillaume. Est-francais.

Stelsel Gotthard. K^upferbahn.

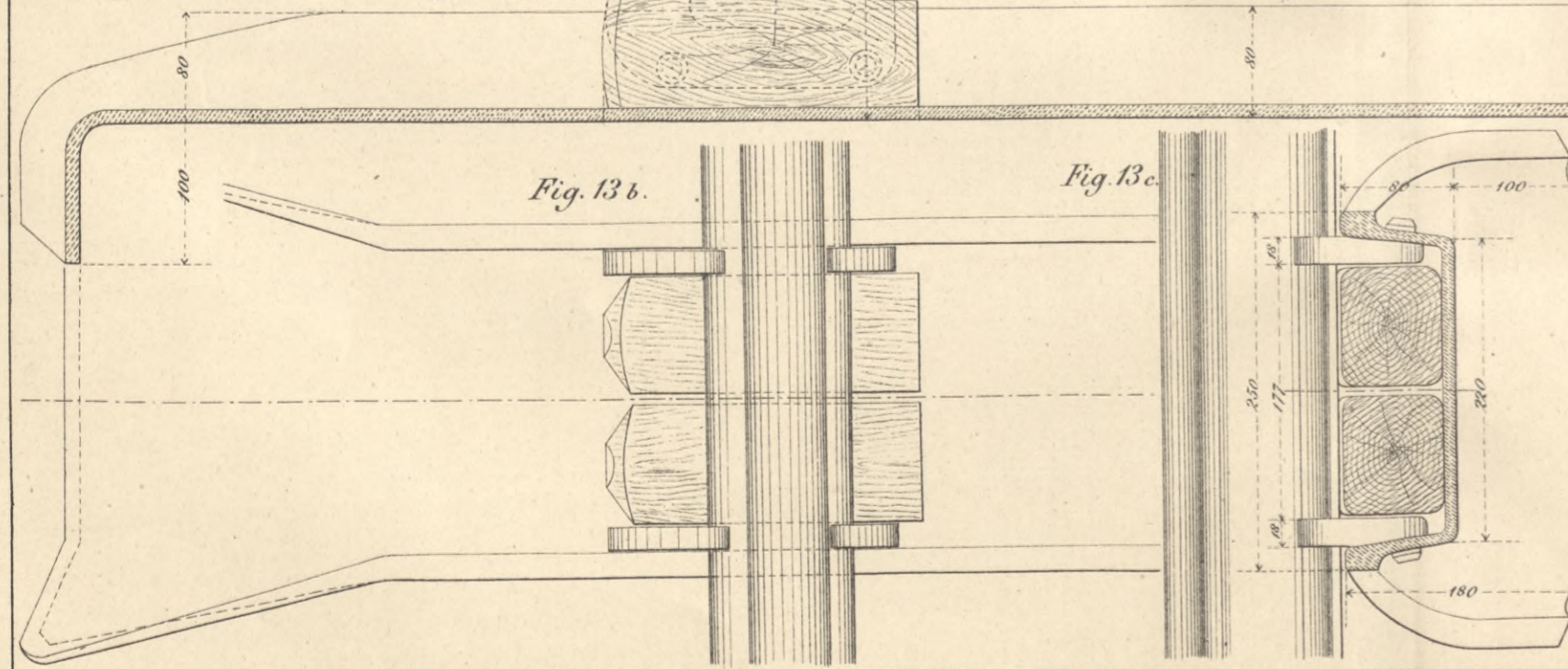
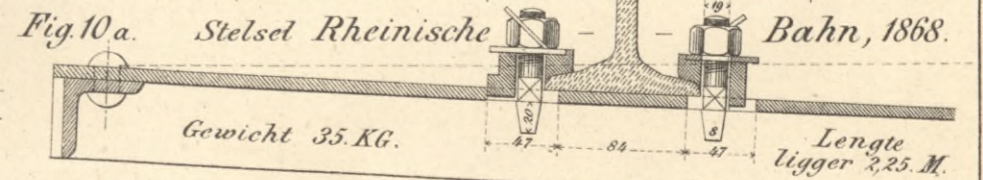
Reichsbahnen. Elsass-Lothringen.

Stelsel Legrand en Sal-kin. Etat-Belge

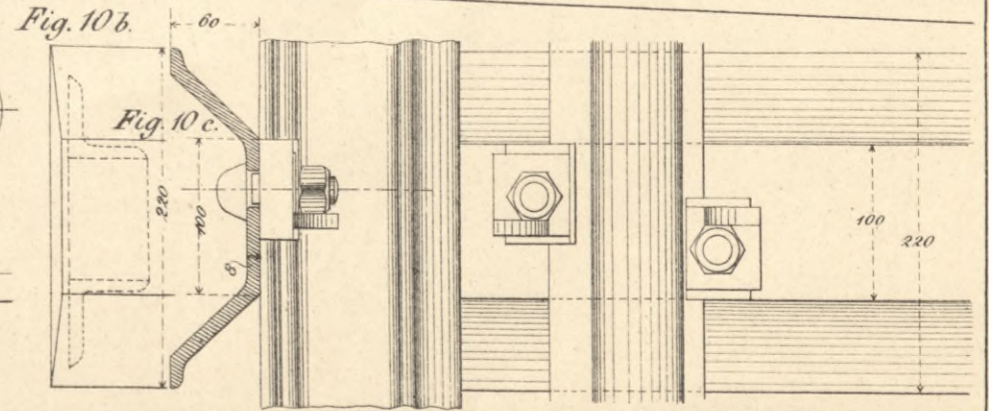
Stelsel Humbert. Est-francais

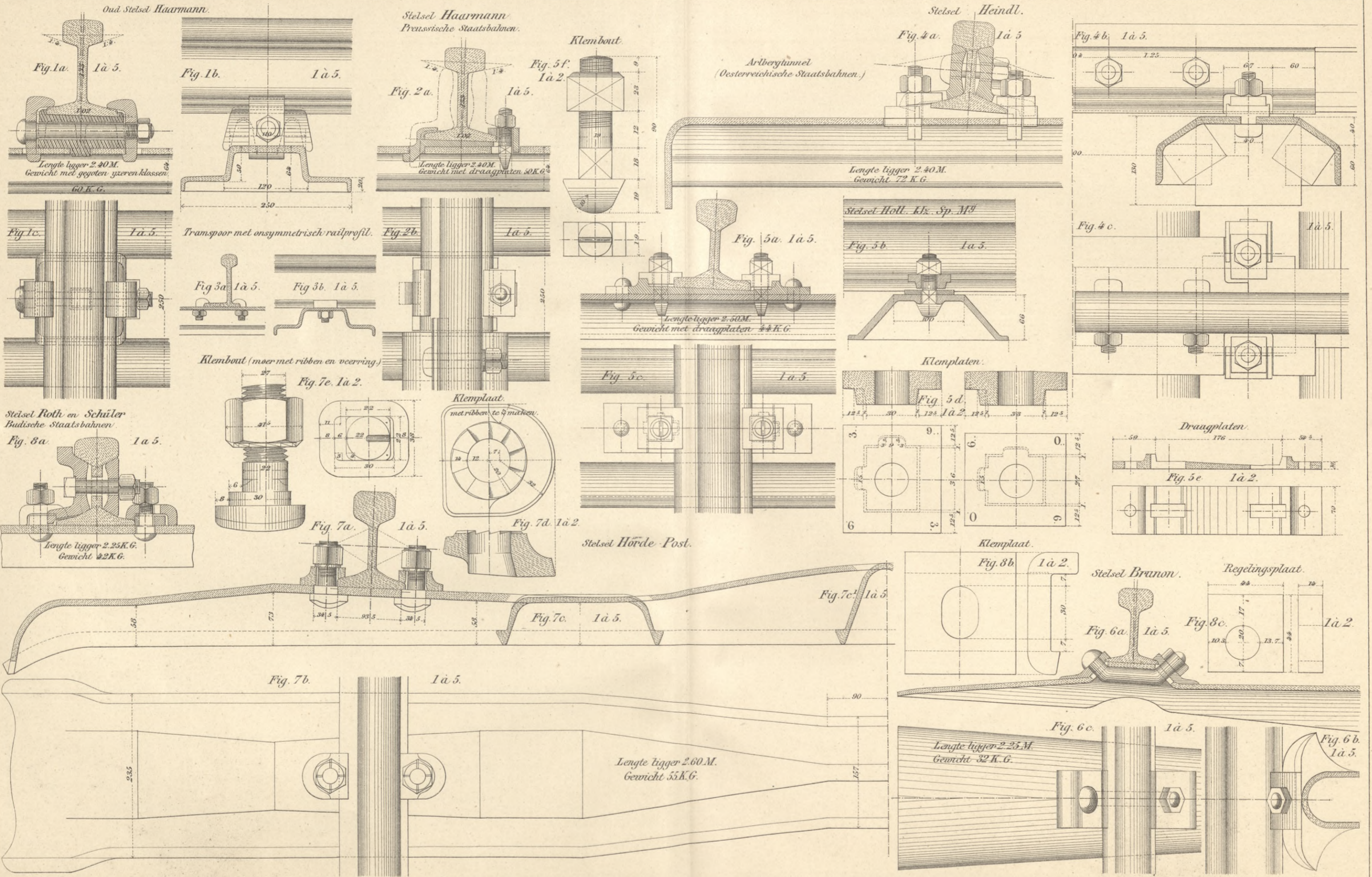
Klemlaten Ruppell. N^o 5, N^o 0.

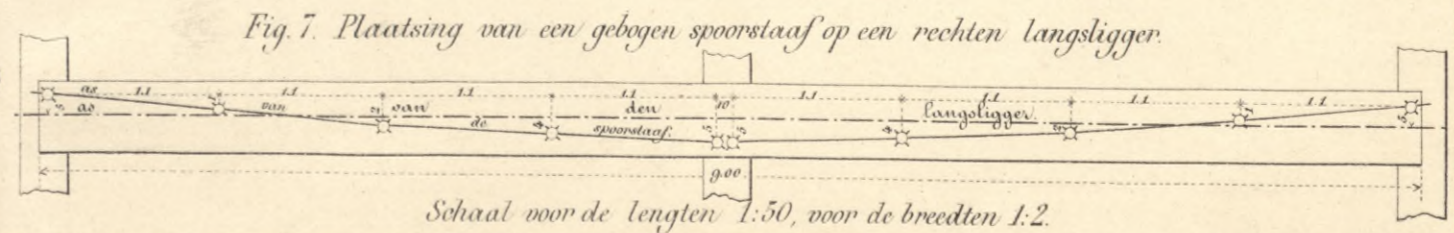
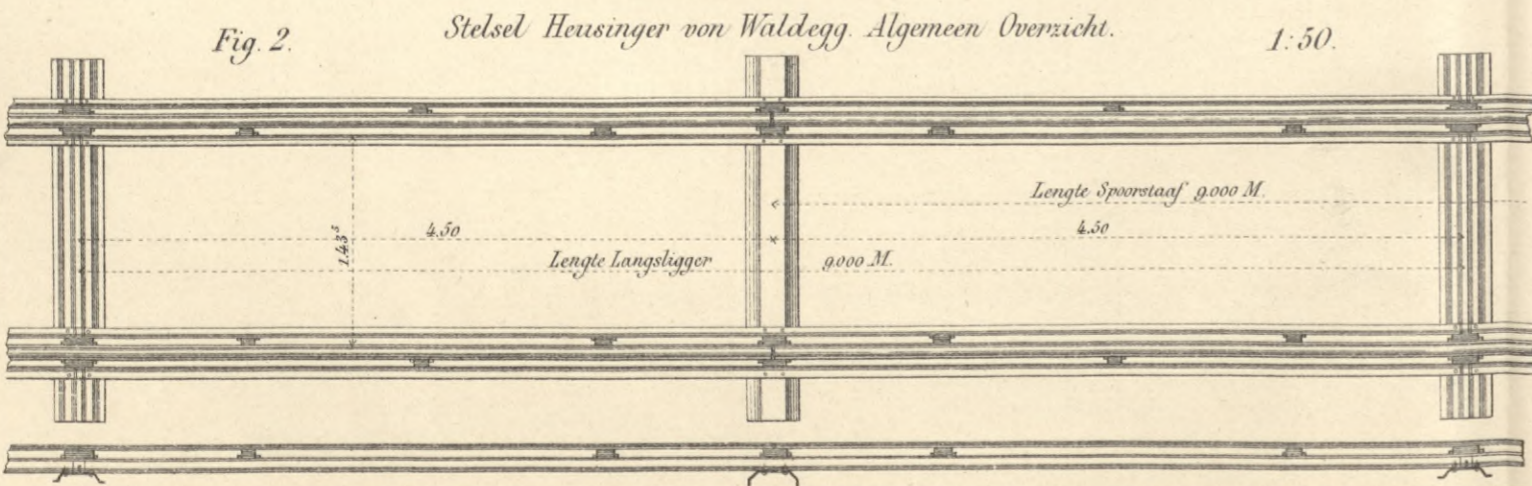
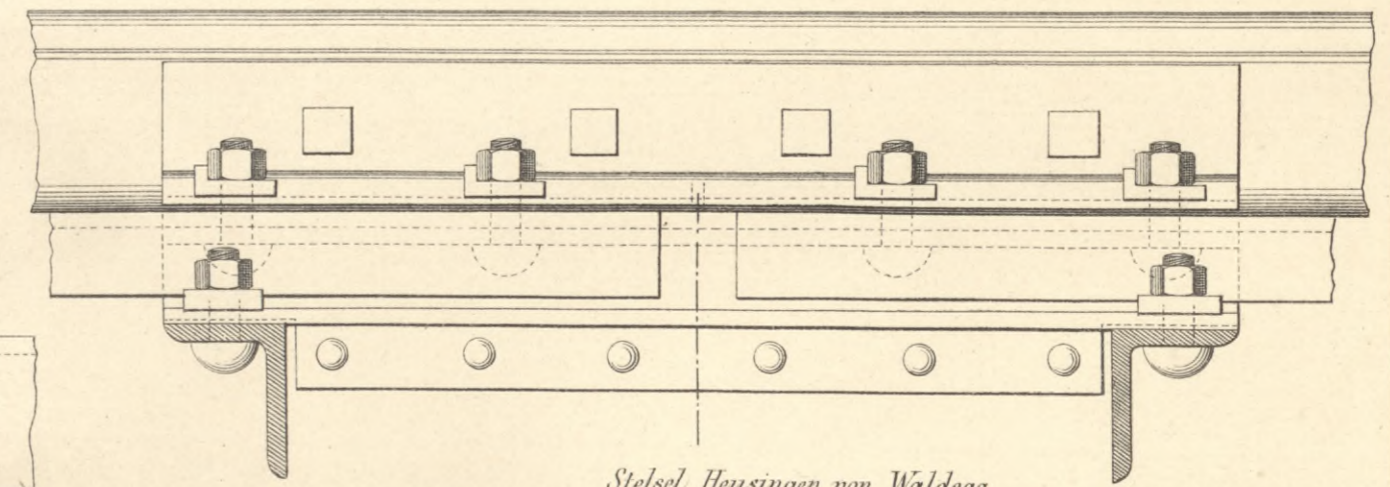
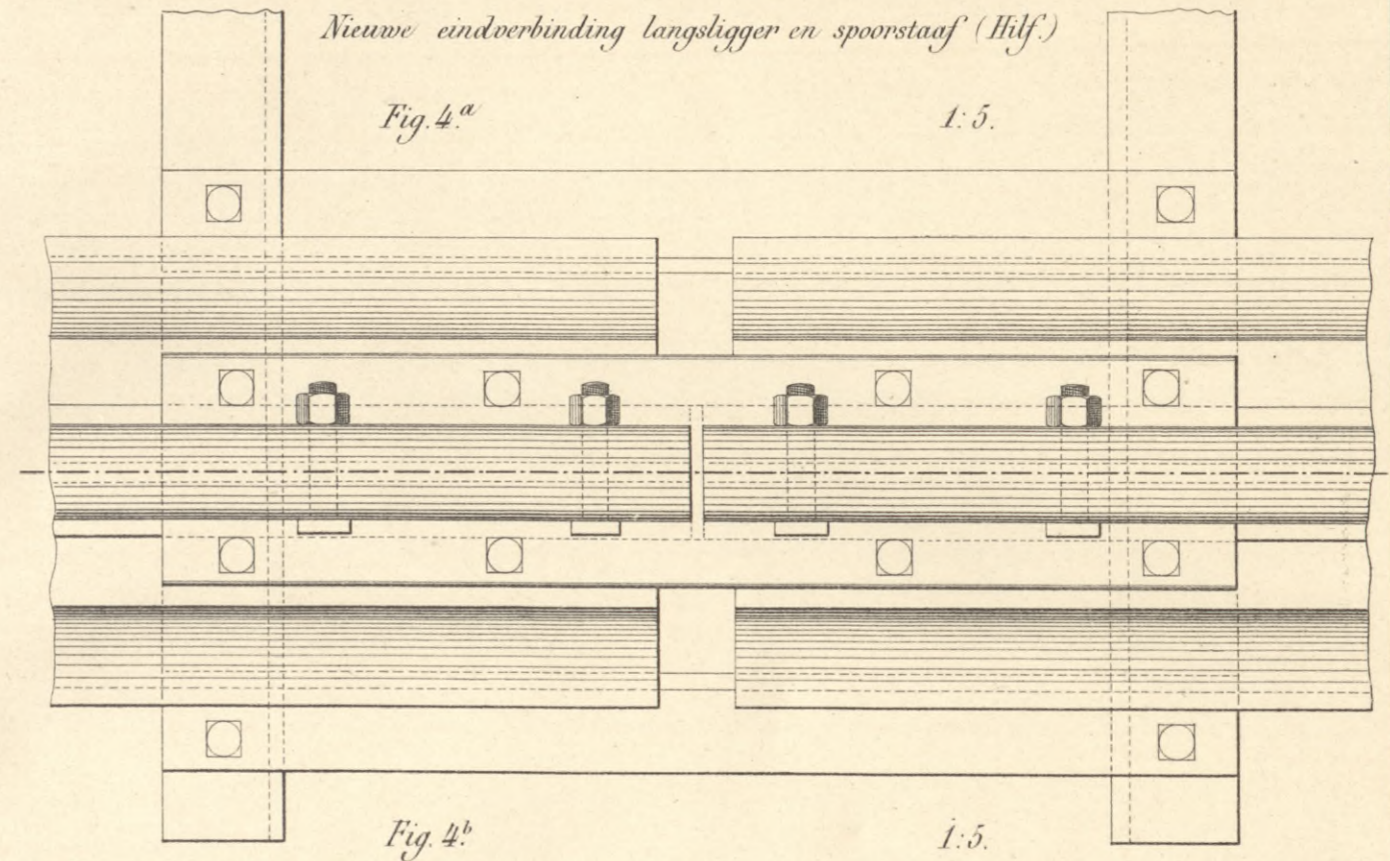
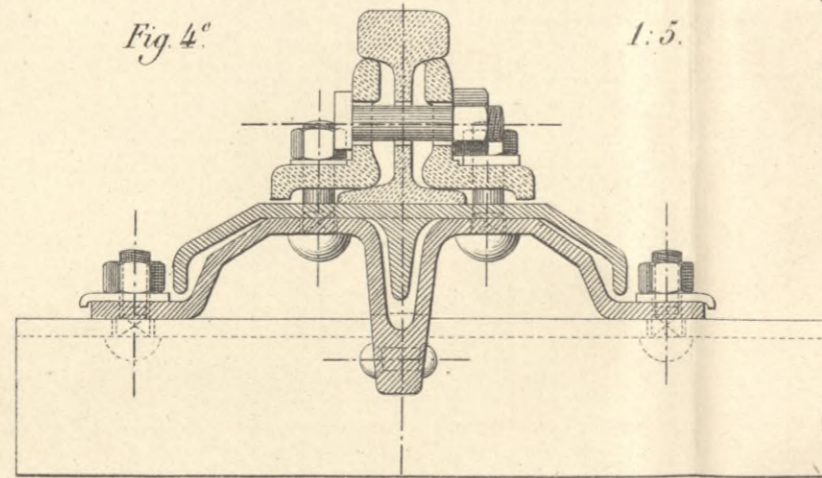
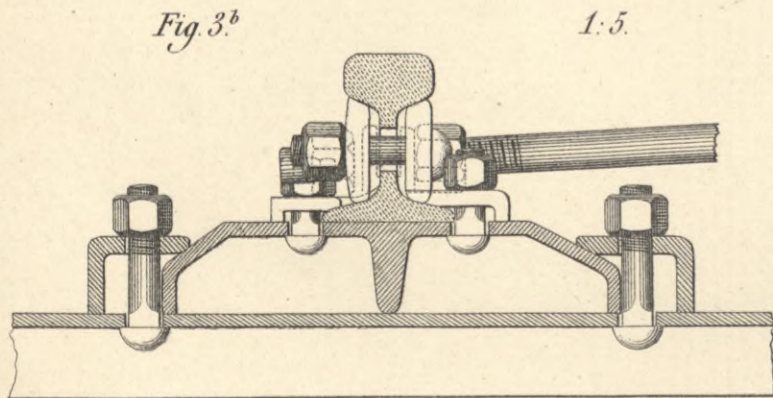
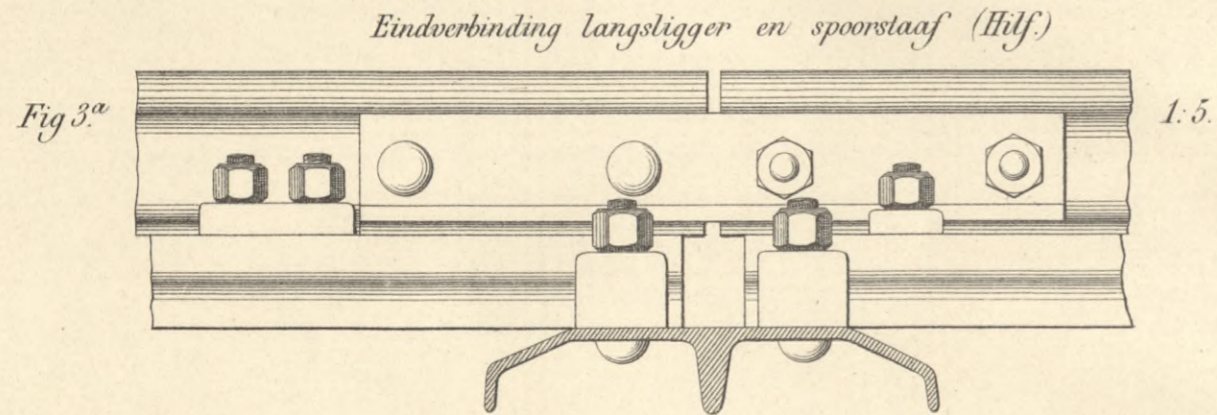
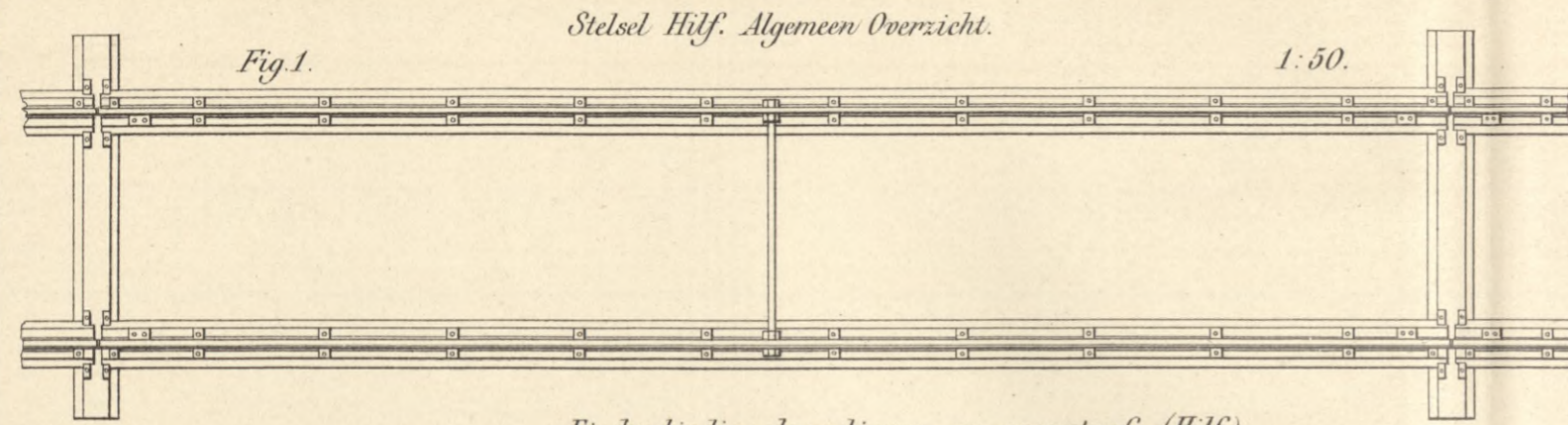
Fig. 10e. 1:2. 1880



Lengte ligger 250 M.
Gewicht 78 KG.







Stelsel Hohenegger Algemeen overzicht.

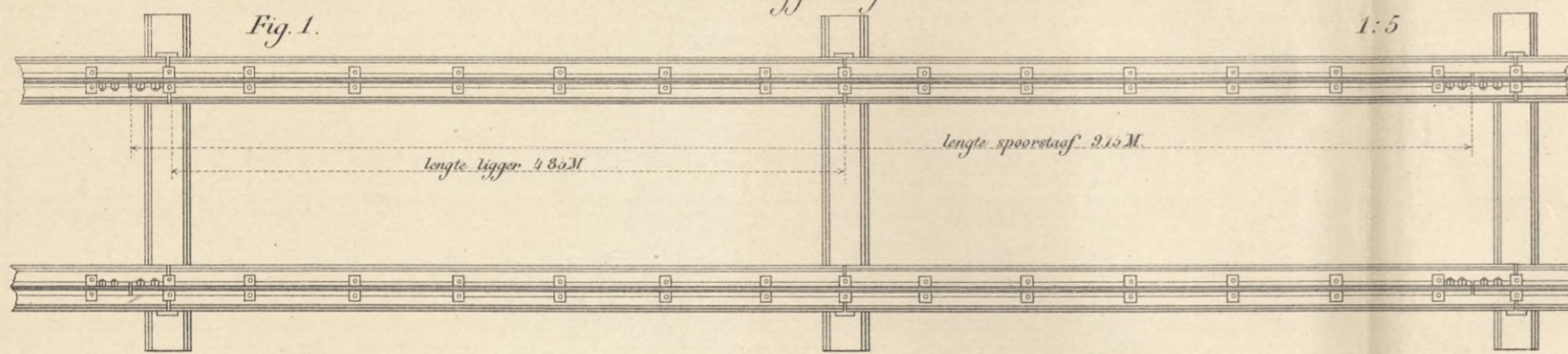
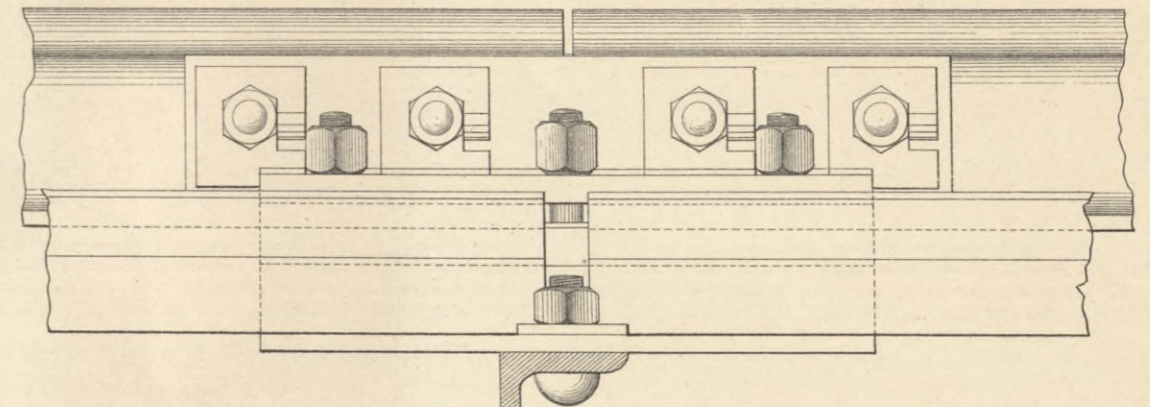
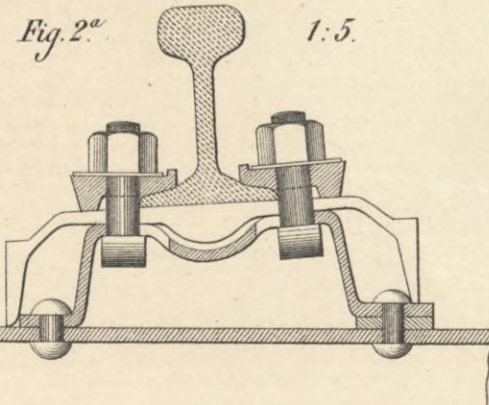


Fig. 3^a Nieuwe eindverbinding langsligger en spoorstaaf (Hohenegger) 1:5.



Eindverbinding langsligger (Hohenegger)



Eindverbinding der spoorstaven (Haarmann)

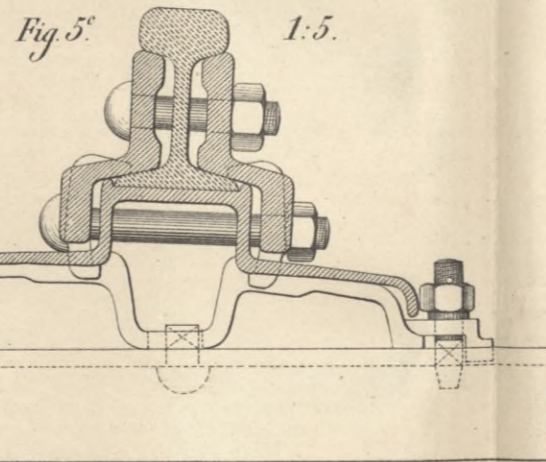


Fig. 3^b 1:5.

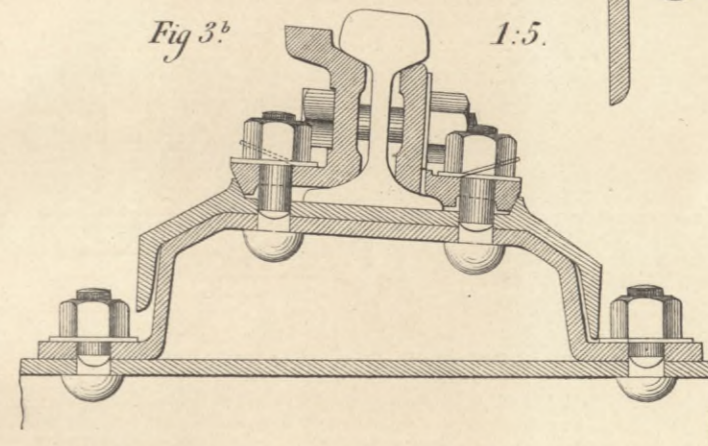


Fig. 3^c 1:5.

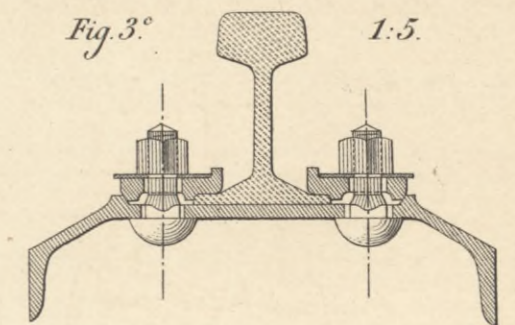
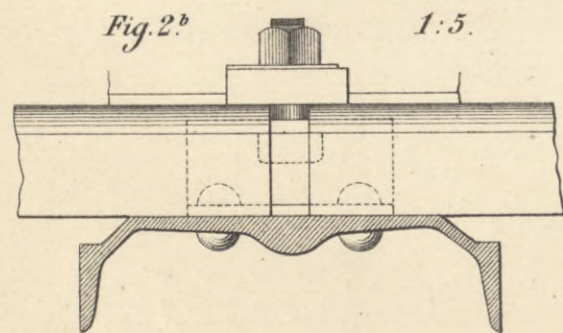
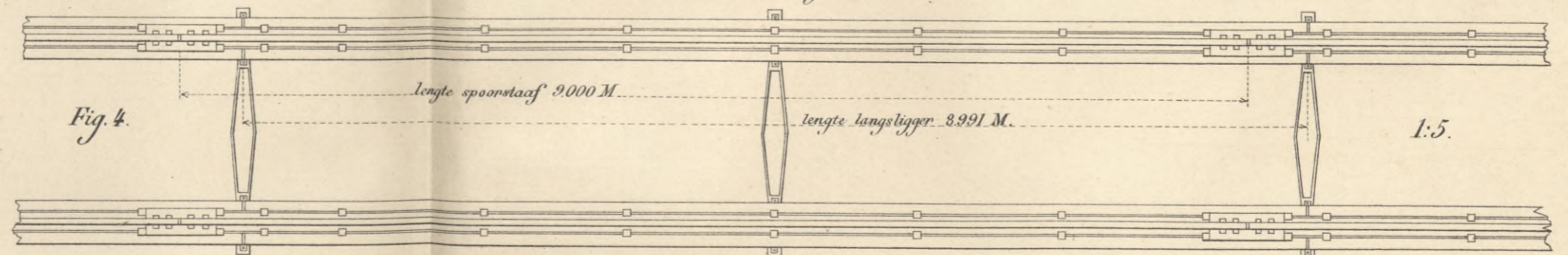


Fig. 2^b 1:5.



Stelsel Haarmann Algemeen overzicht.



Eindverbinding langsligger (Haarmann)

Fig. 5^b 1:5.

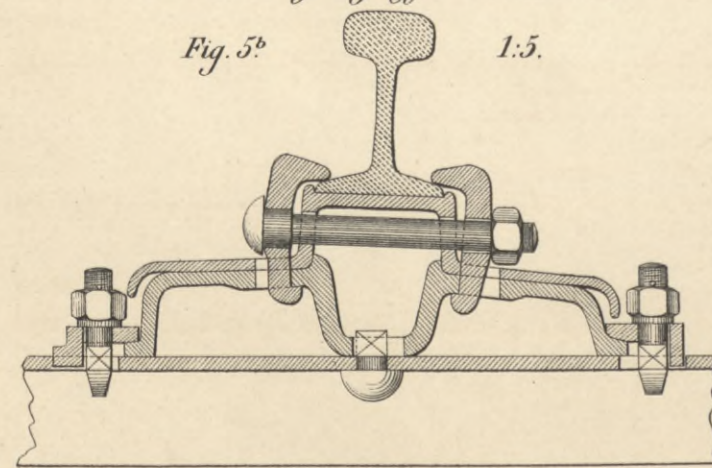
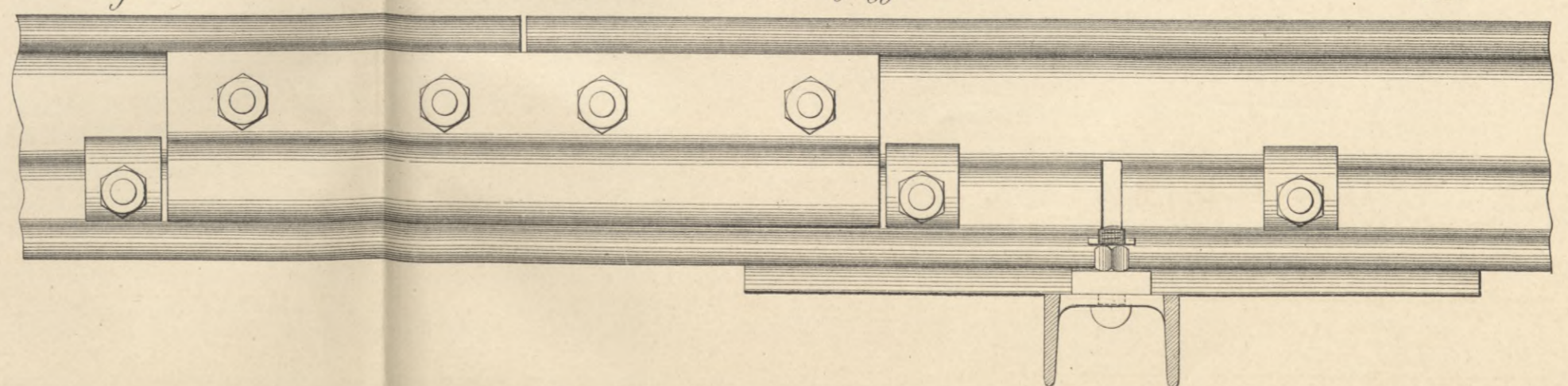
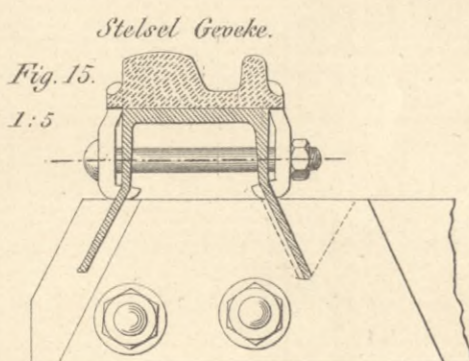
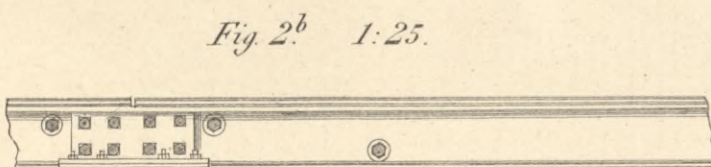
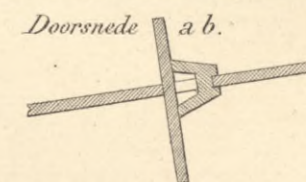
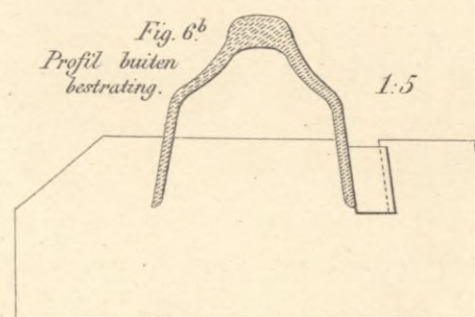
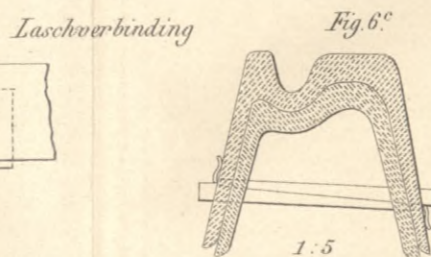
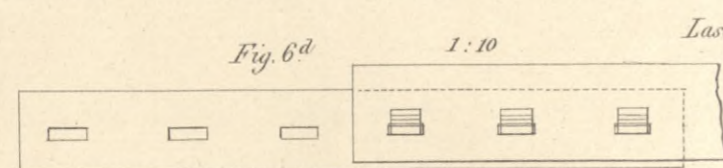
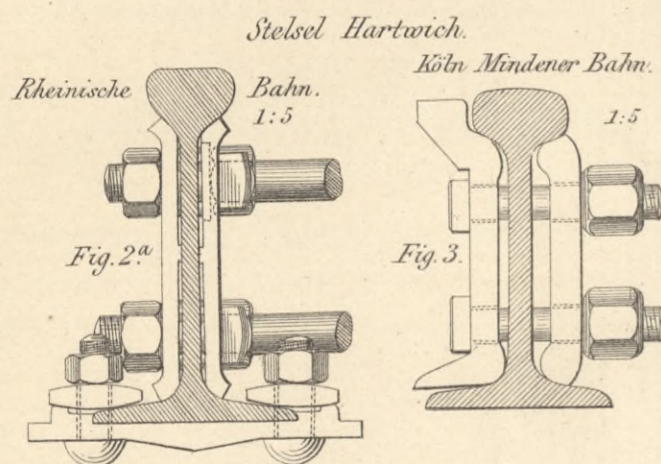
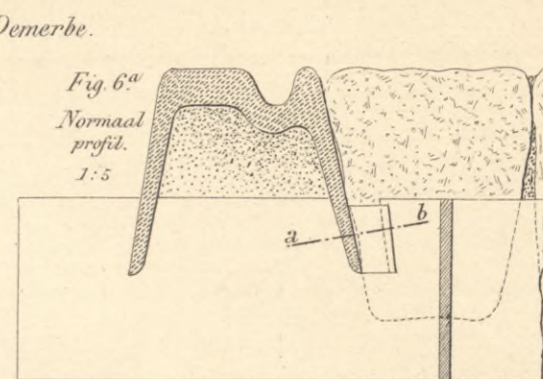
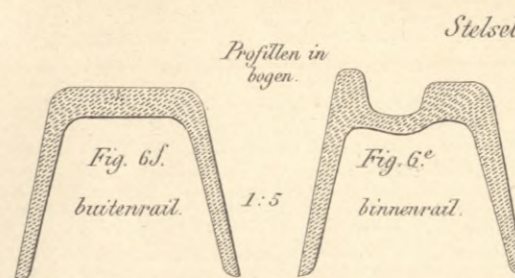
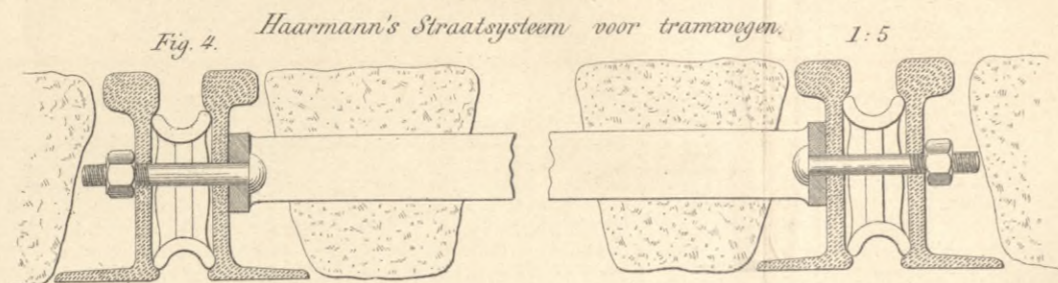
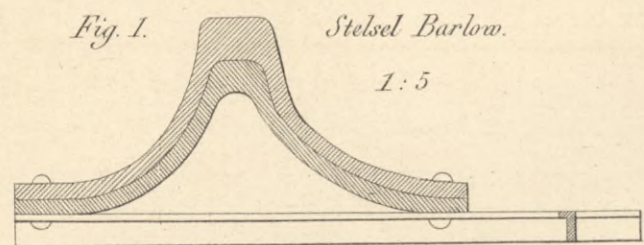


Fig. 5^a

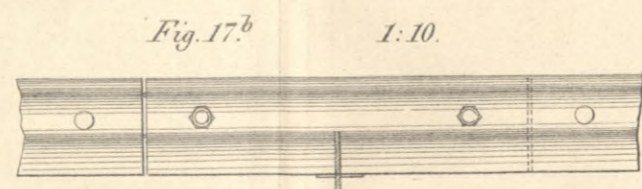
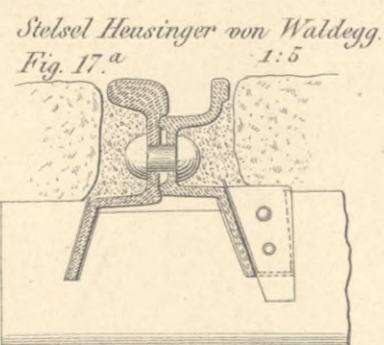
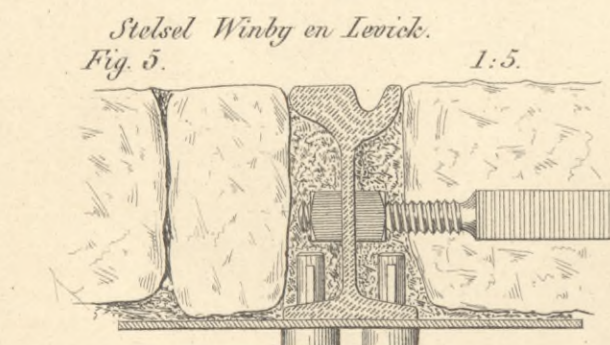
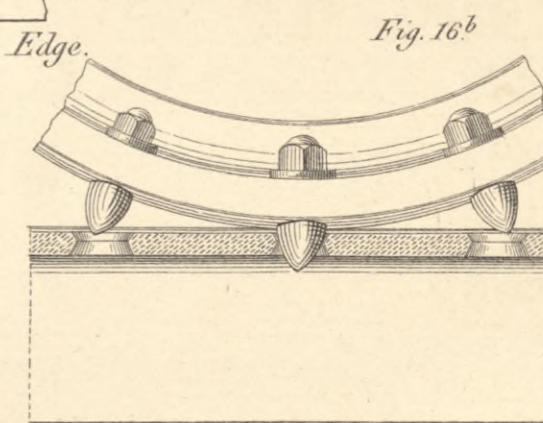
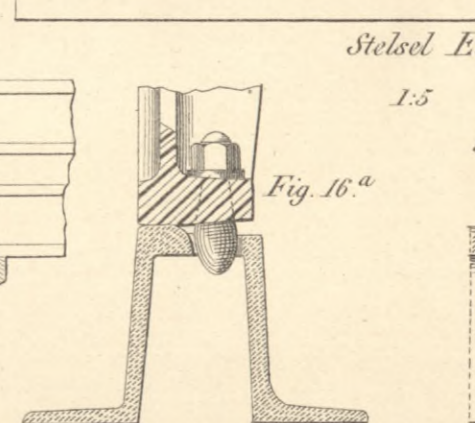
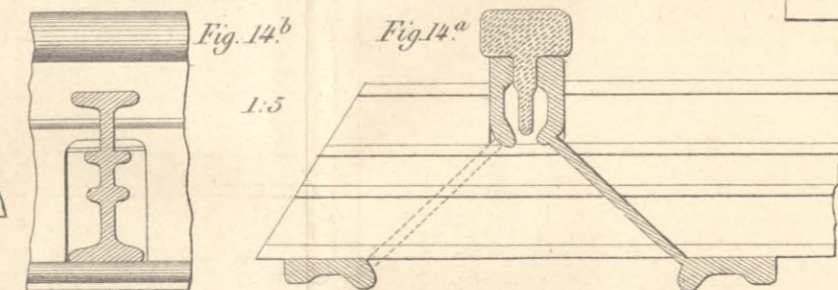
Eindverbinding der spoorstaven en der langsliggers (Haarmann) Aanzicht.

1:5.

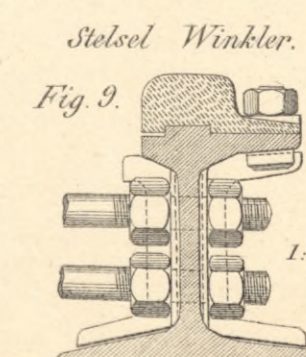
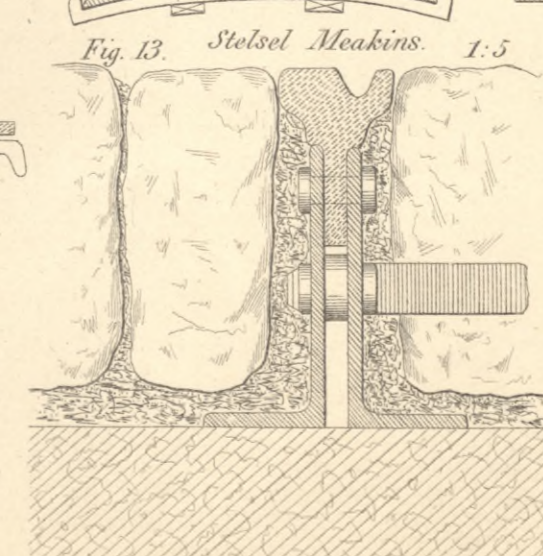
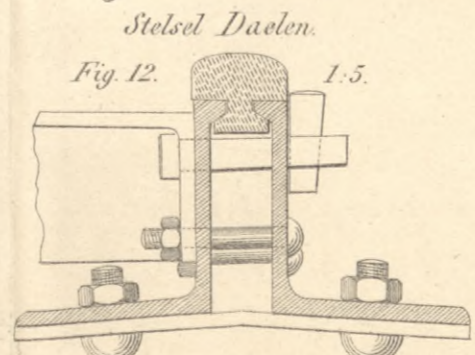
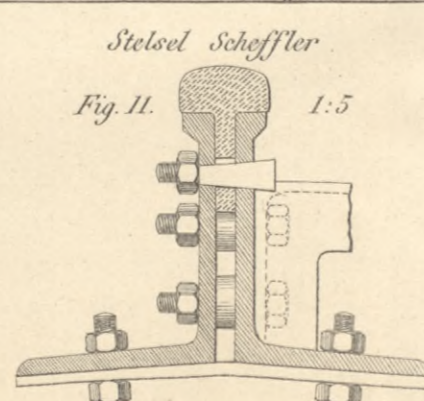
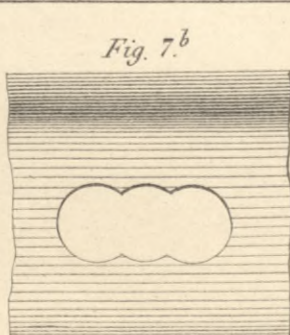
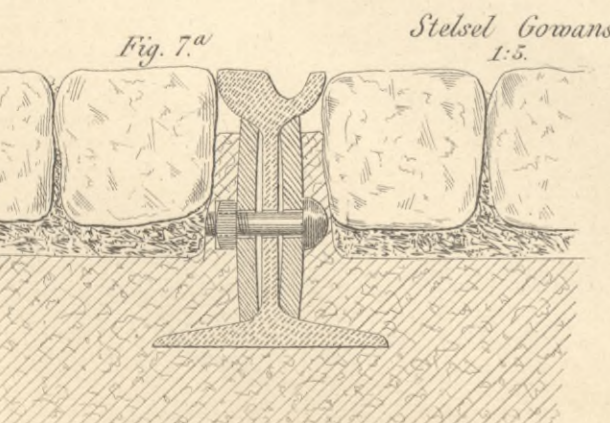
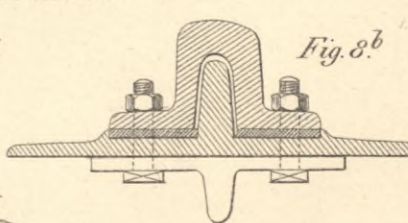
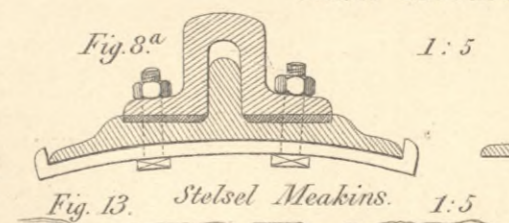
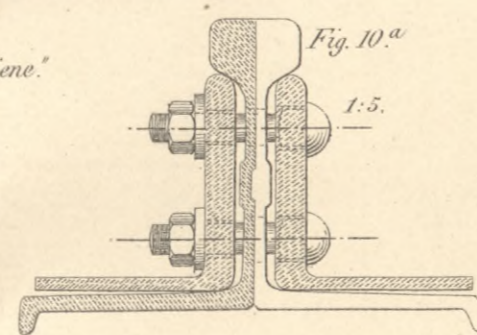
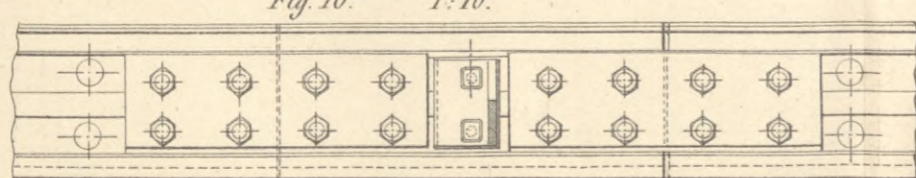




Stelsel de Serres en Battig.



Haarmann's, Schwellenschiene.



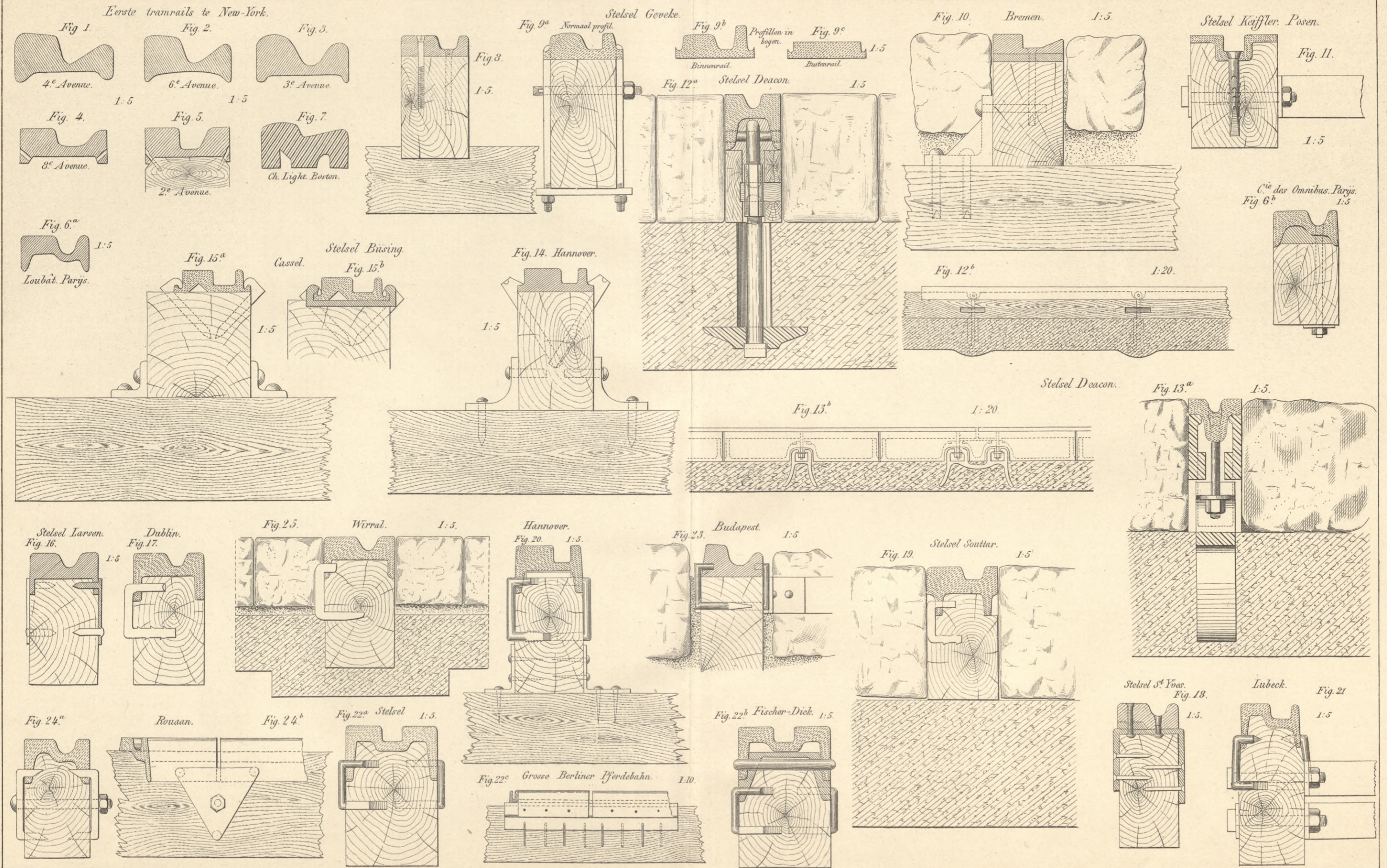


Fig. 1^a Stelsel Mackison. 1:5.

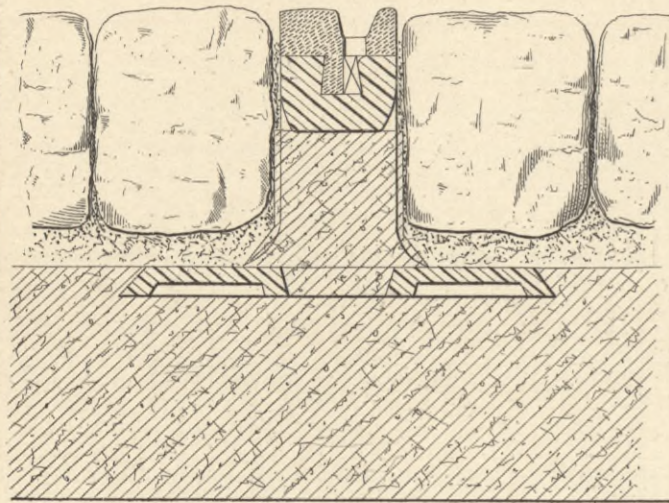


Fig. 2. Stelsel Kerr. 1:5.

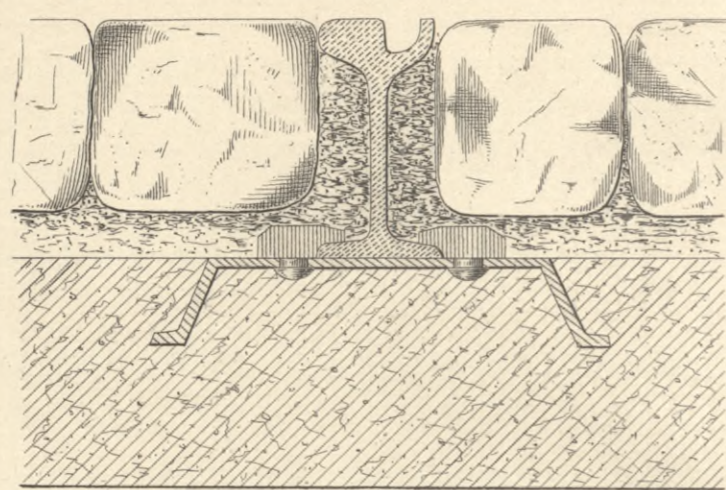


Fig. 3. Stelsel Aldred en Spielmann. 1:5.

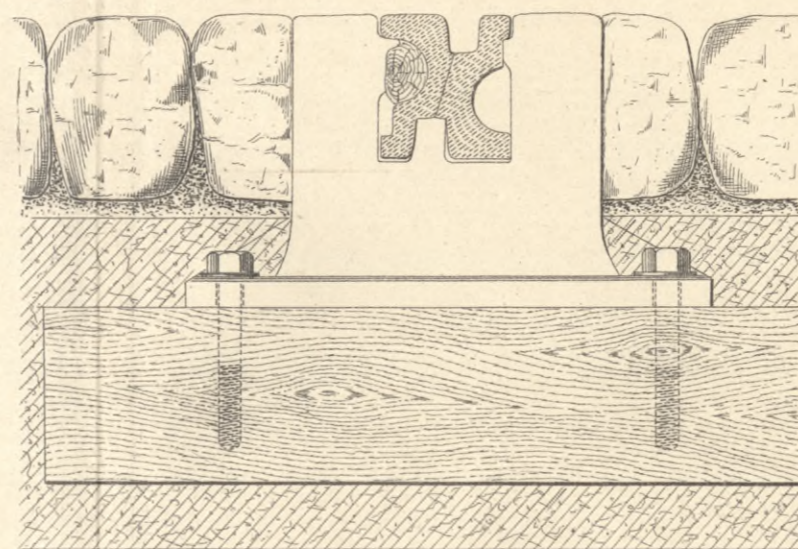


Fig. 4. Stelsel Truswell. 1:5.

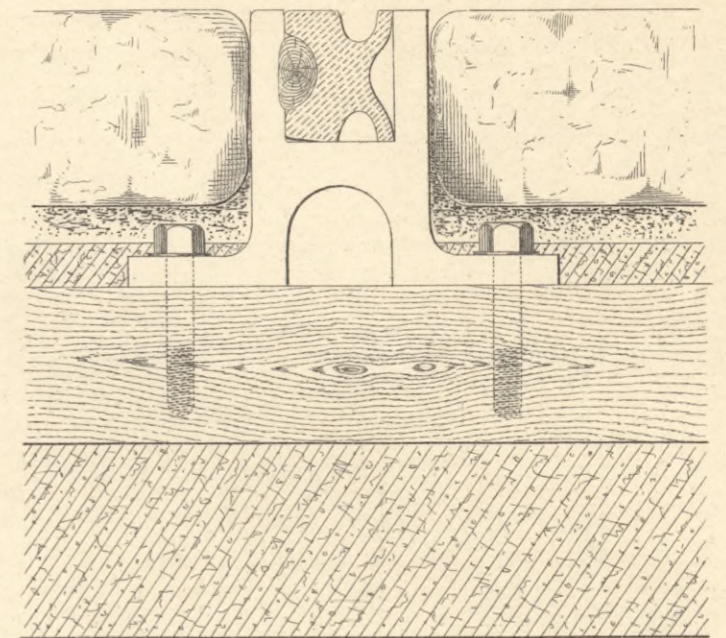


Fig. 1^b

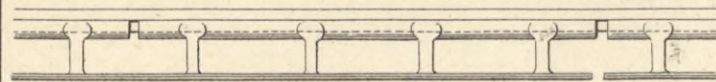


Fig. 1^c 1:20.

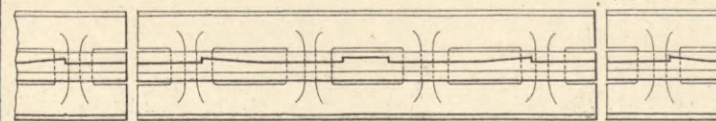


Fig. 6^a Stelsel Shaw. 1:5.

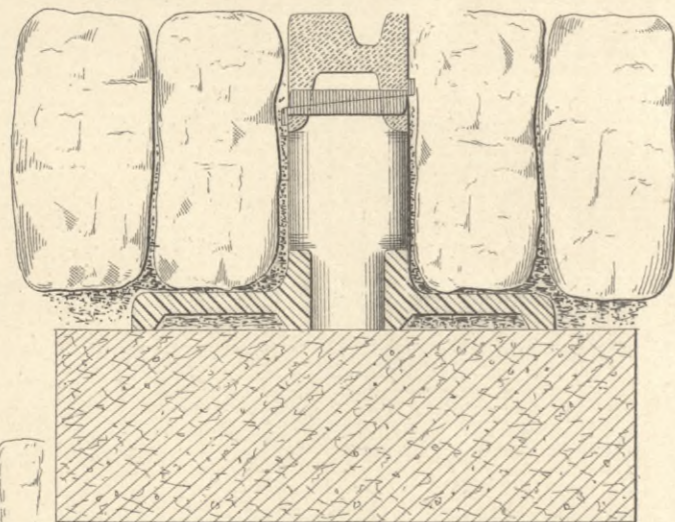
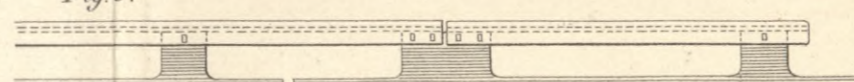


Fig. 6^b



1:20.

Fig. 6^c

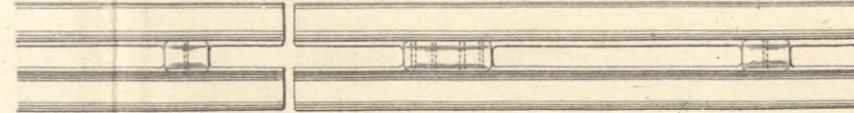


Fig. 7^a Stelsel Vignoles. 1:5.

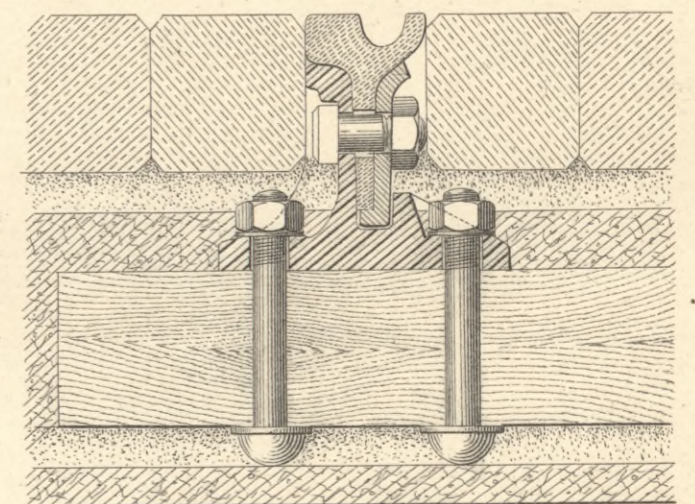


Fig. 5^a Stelsel Dugdale. 1:5.

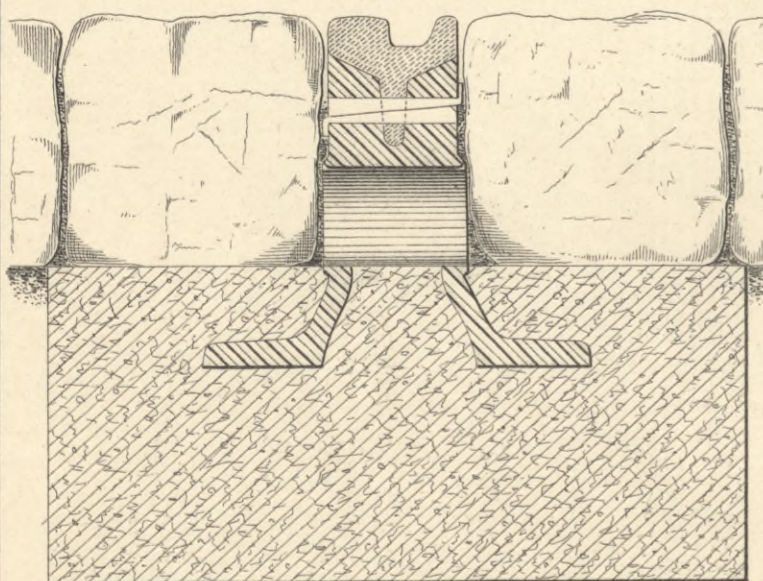


Fig. 8^a Stelsel Hincaid. 1:5.

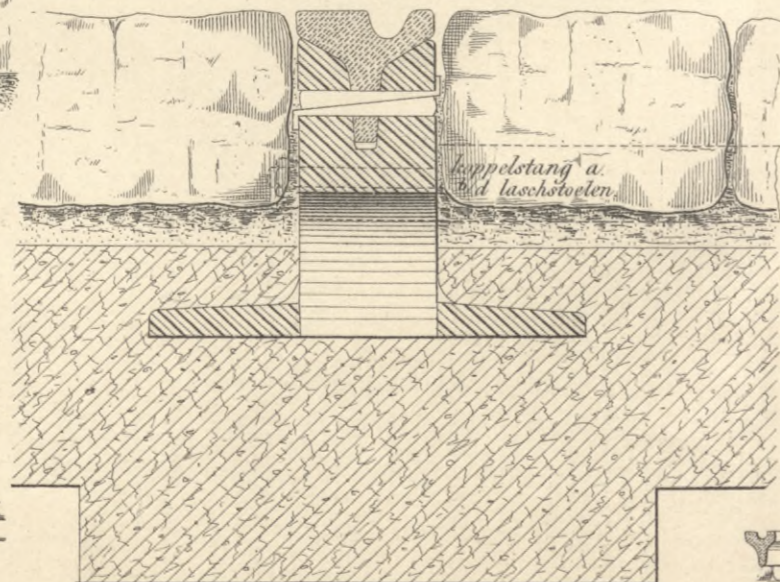


Fig. 9^a Stelsel Wilson. 1:5.

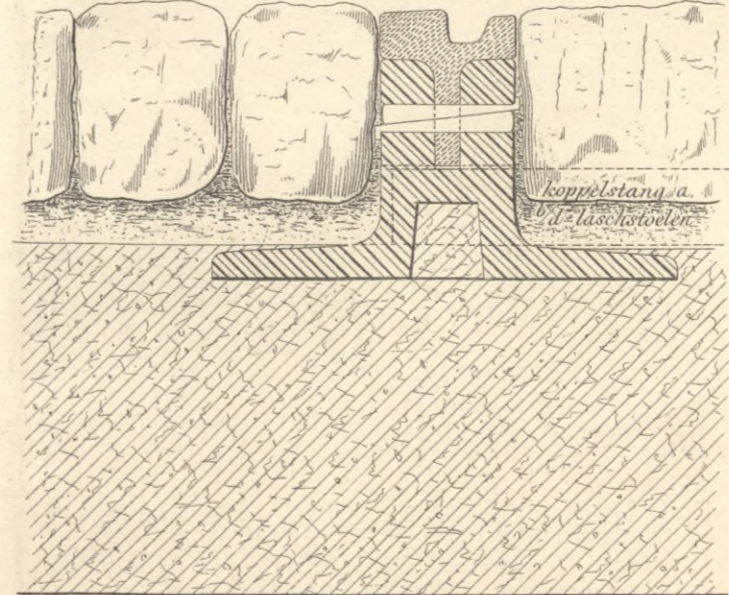


Fig. 7^b 1:20.



Fig. 5^b 1:20.

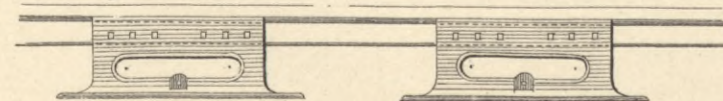


Fig. 8^b 1:20.

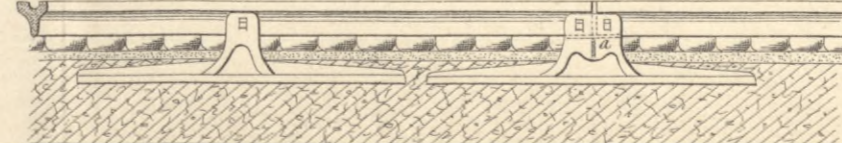
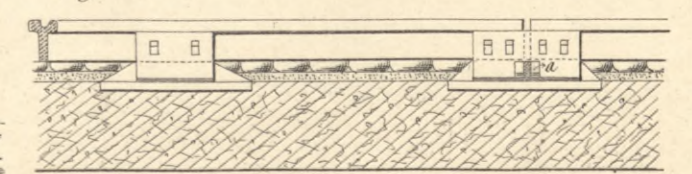
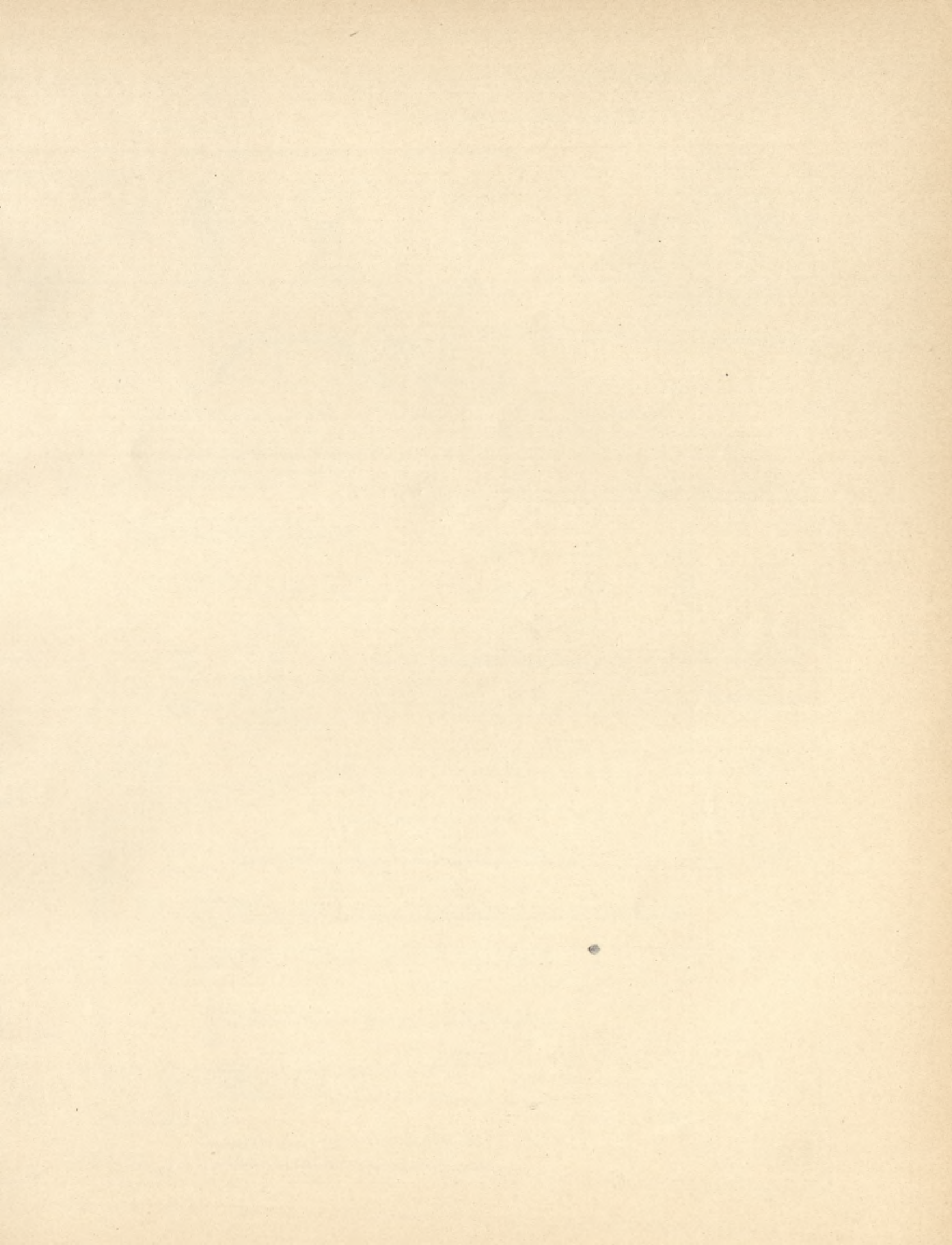


Fig. 9^b 1:20.





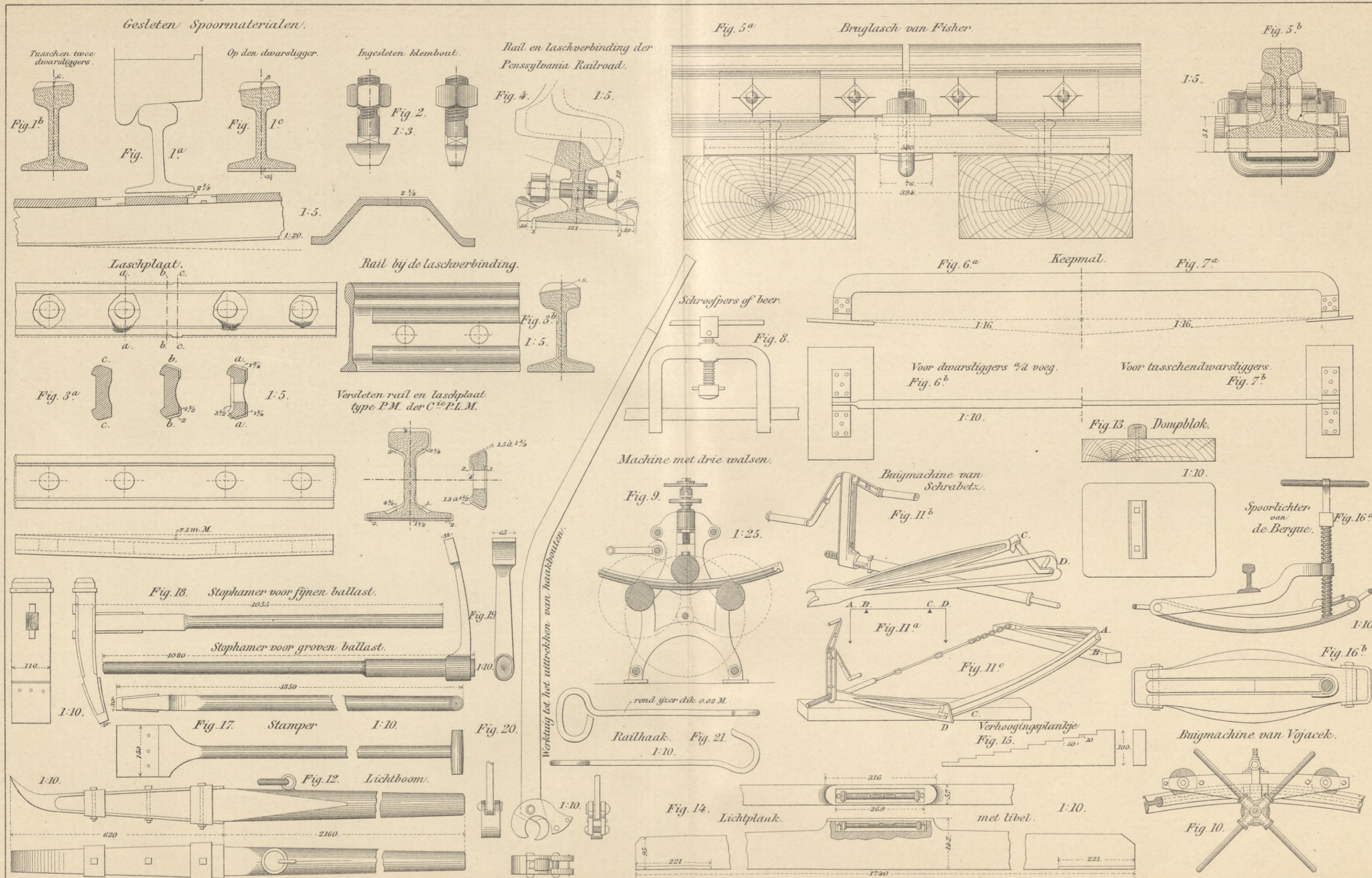


Fig. 1^a
Sleepwissel van Stephenson. 1:50.

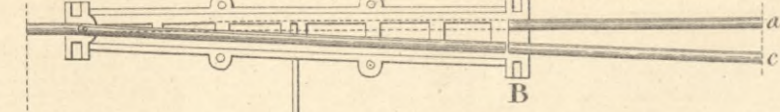


Fig. 1^b

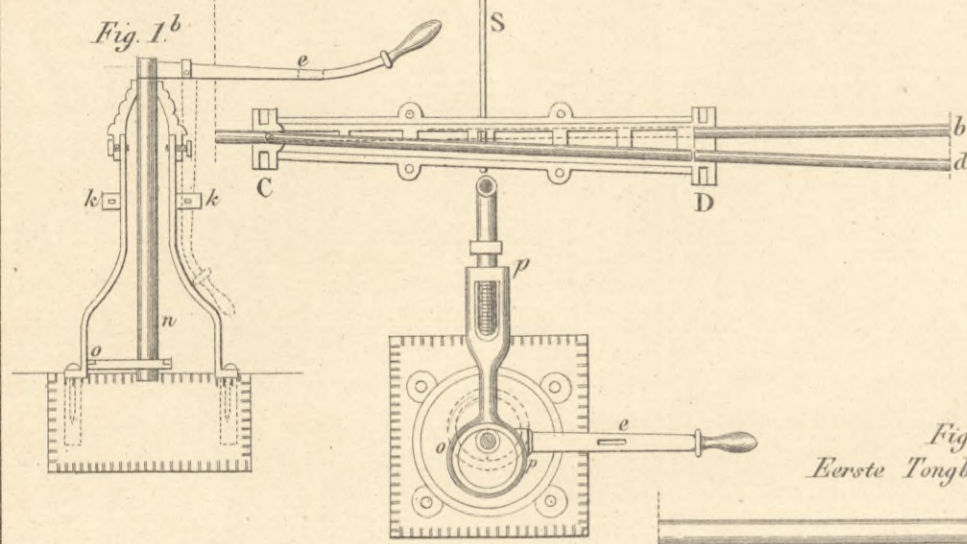


Fig. 2.
Dubbele Sleepwissel. 1:60.

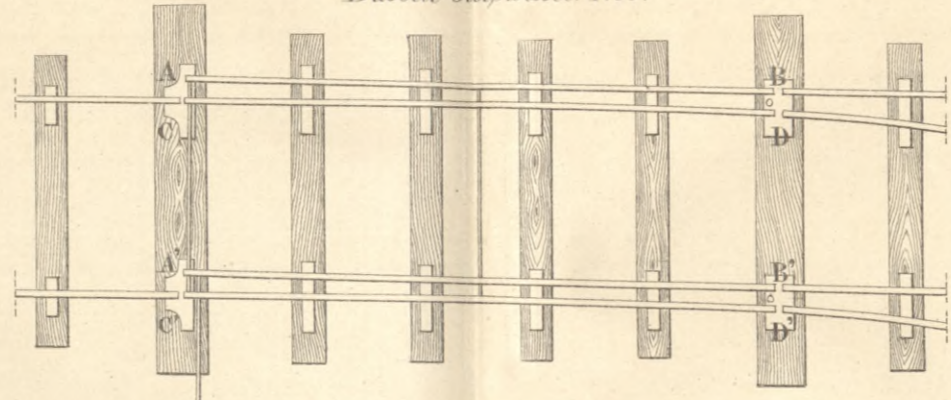


Fig. 3.
Sleepwissel van Poiriet. 1:60.

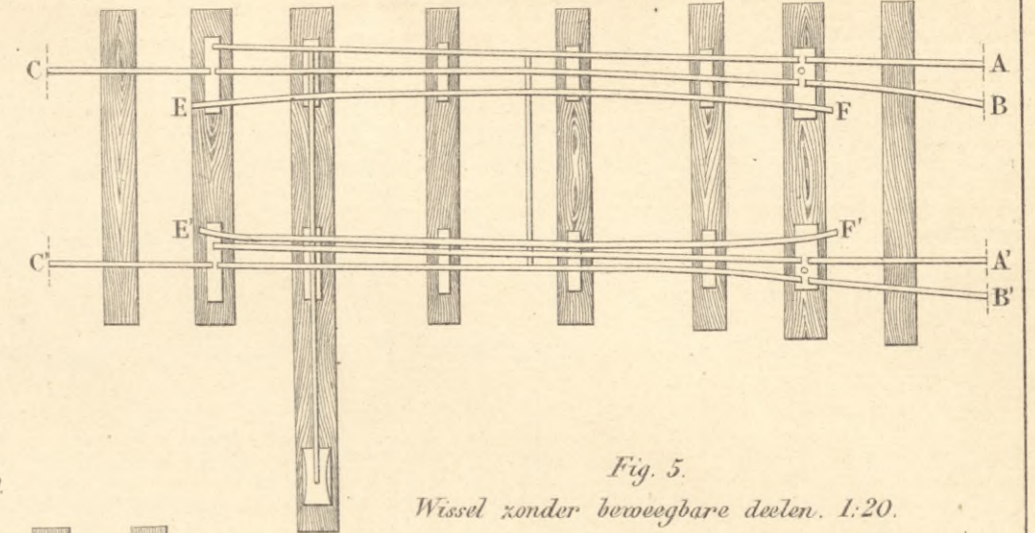


Fig. 8.
Wissel met beweegbare contrarail. 1:60.

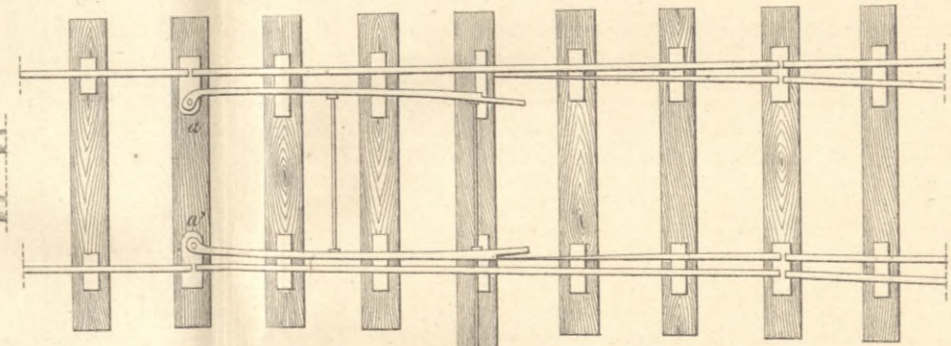


Fig. 5.
Wissel zonder beweegbare deelen. 1:20.

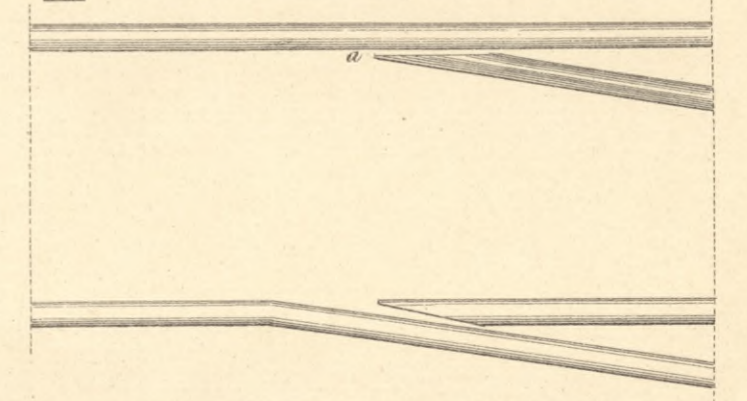


Fig. 9.
Eerste Tongbeweging. 1:20.



Fig. 10.
Wissel met ééne tong van Stephenson. 1:60.

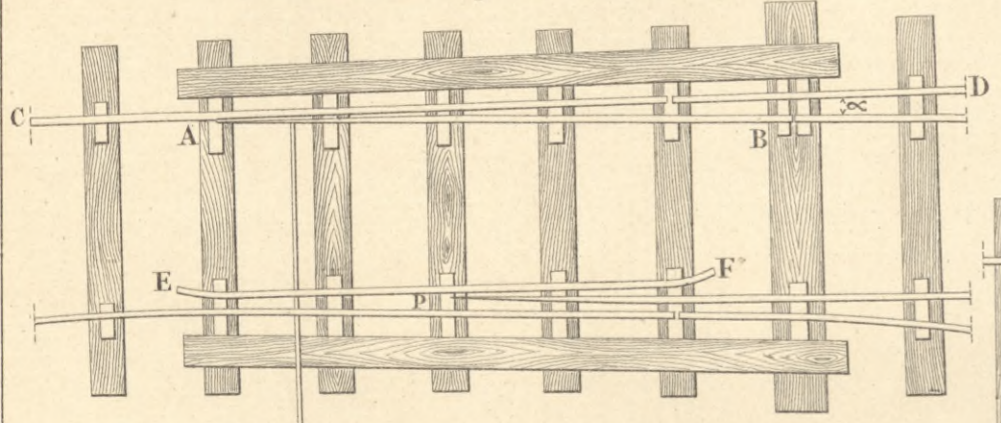


Fig. 13.
Wissel met even lange tongen. 1:60.

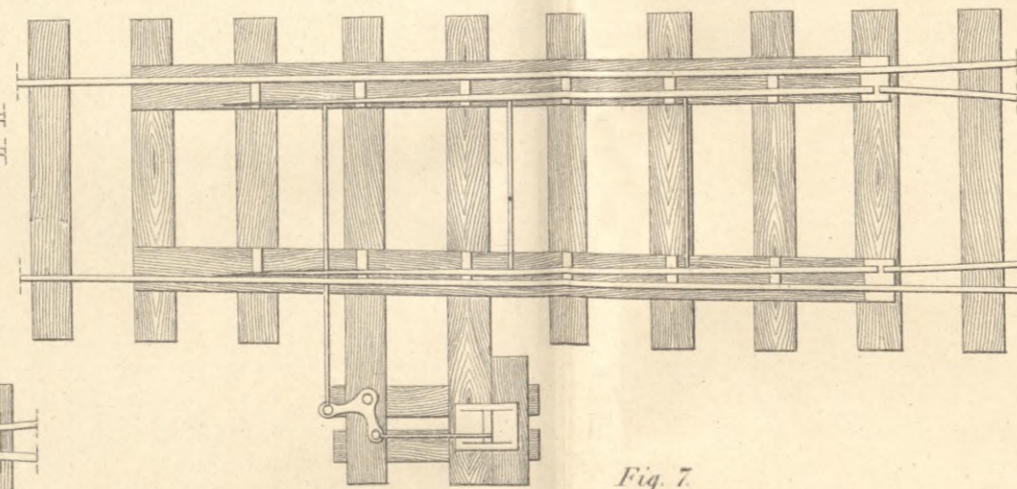


Fig. 6^a
Wissel voor tramwegen. 1:27,5

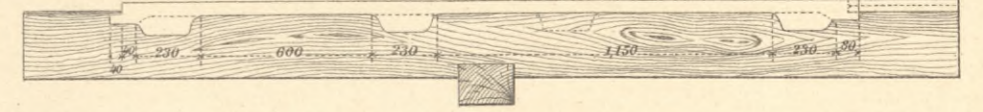


Fig. 6^e
Aanzicht a.

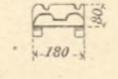


Fig. 6^f
Aanzicht b.

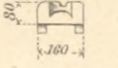


Fig. 6^b Rechterdeel.

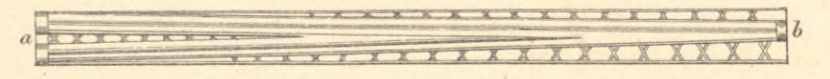


Fig. 6^c Linkerdeel.

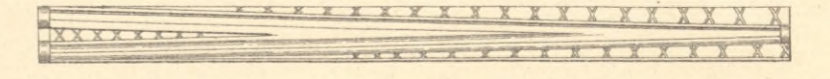


Fig. 6^d Doorsnede.

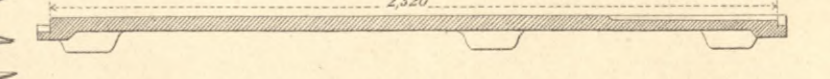


Fig. 11.
Wissel met ongelijk lange tongen. 1:60.

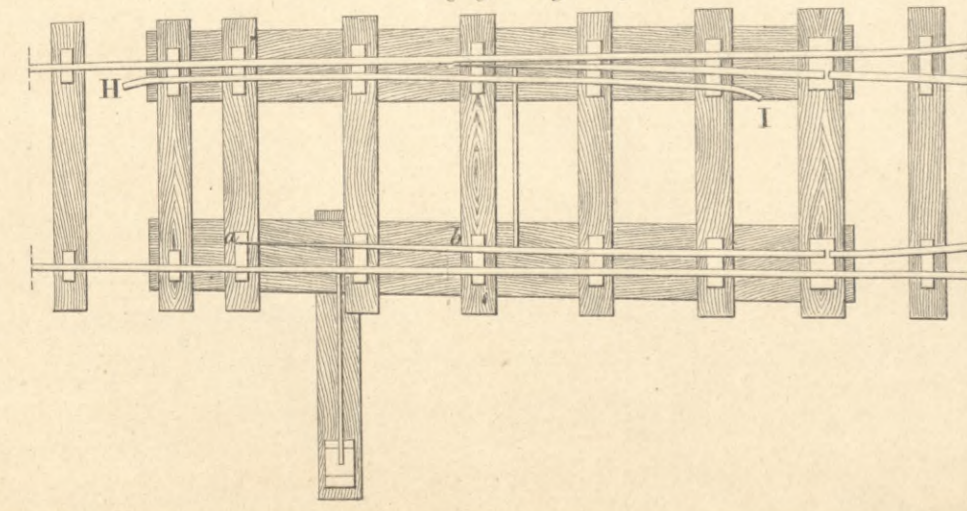


Fig. 7.
Wissel voor Tramwegen. 1:20.



Fig. 12.
Aanslaande tong voor tramwegwissels. 1:25.

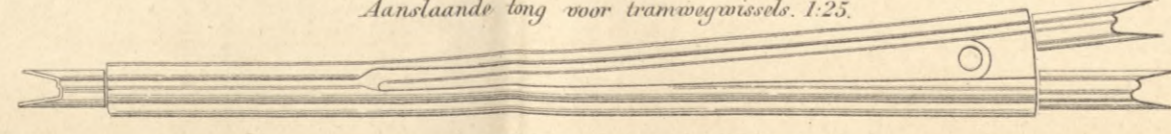
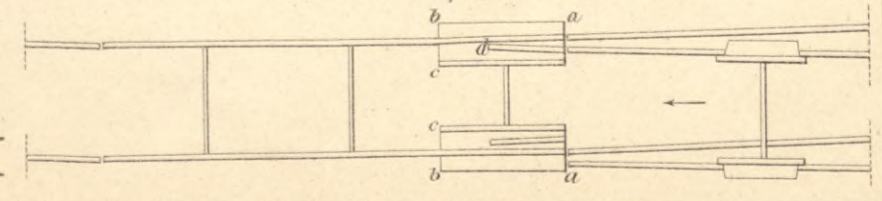
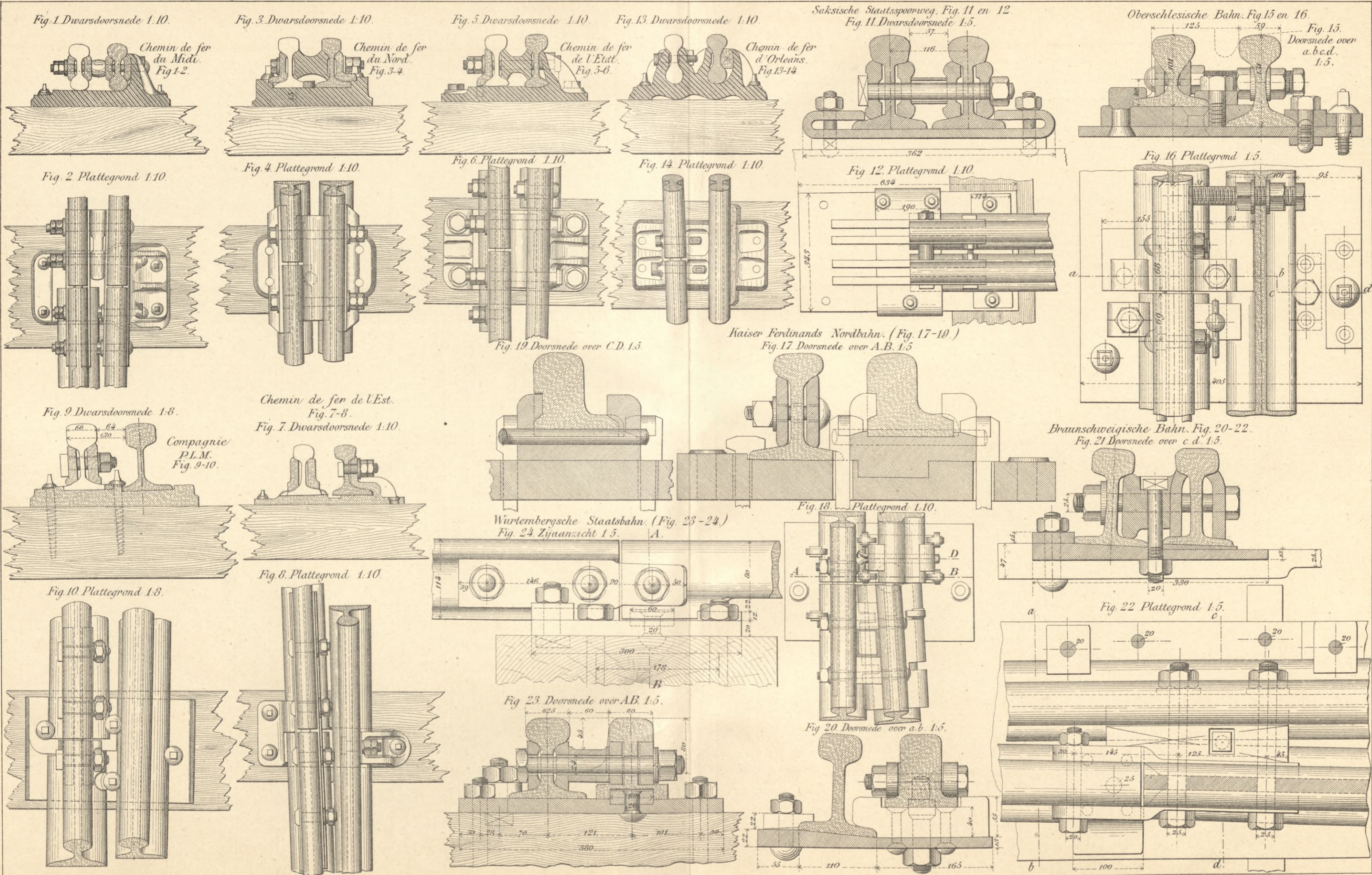


Fig. 4.
Verbeterd Sleepwissel. 1:100.





Maatschappij tot Exploitatie van Staatsspoorwegen.

Wissel op langsliggers. Fig. 1-8.

Fig. 2. Doorsnede over A.B. 1:20.

Fig. 1. Platte grond. 1:20.

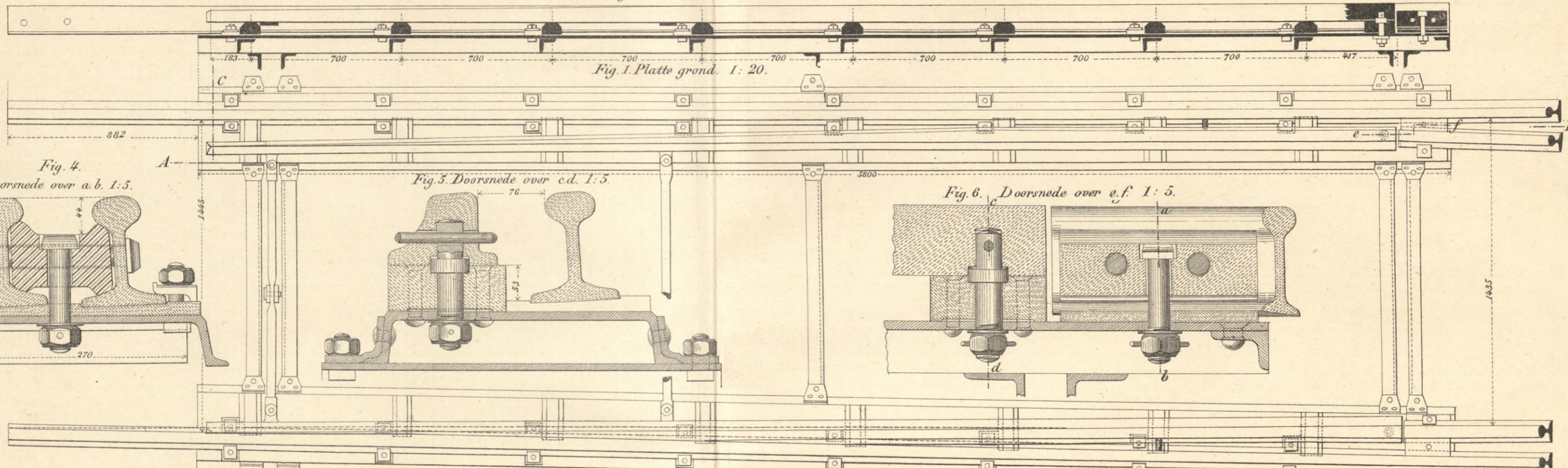


Fig. 4. Doorsnede over a.b. 1:5.

Fig. 5. Doorsnede over c.d. 1:5.

Fig. 6. Doorsnede over e.f. 1:5.

Fig. 13. Glijdstoel. Zijaanzicht 1:5.

Fig. 11. Doorsnede over x.y. 1:5.

Fig. 10. Draaistoel. Langsdoorsnede. 1:5.

Maatschappij tot Exploitatie van Staatsspoorwegen. Wissel op dwarsliggers. Fig. 9-17.

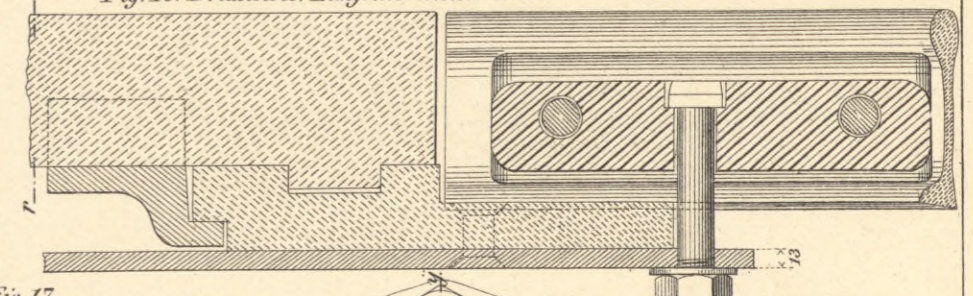
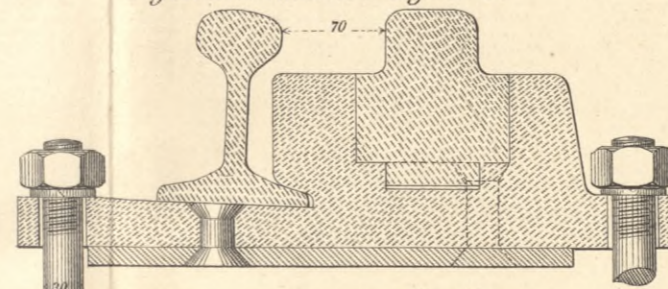
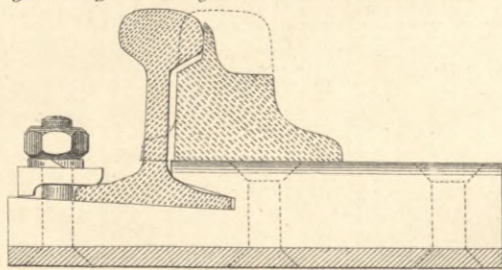


Fig. 15. Doorsnede nabij de verbindingsstang. 1:5.

Fig. 16. Doorsnede bij een steunbout. 1:5.

Fig. 17. Doorsn. over p.q. 1:5.

Fig. 9. Draaistoel. Bovenaanzicht. 1:5.

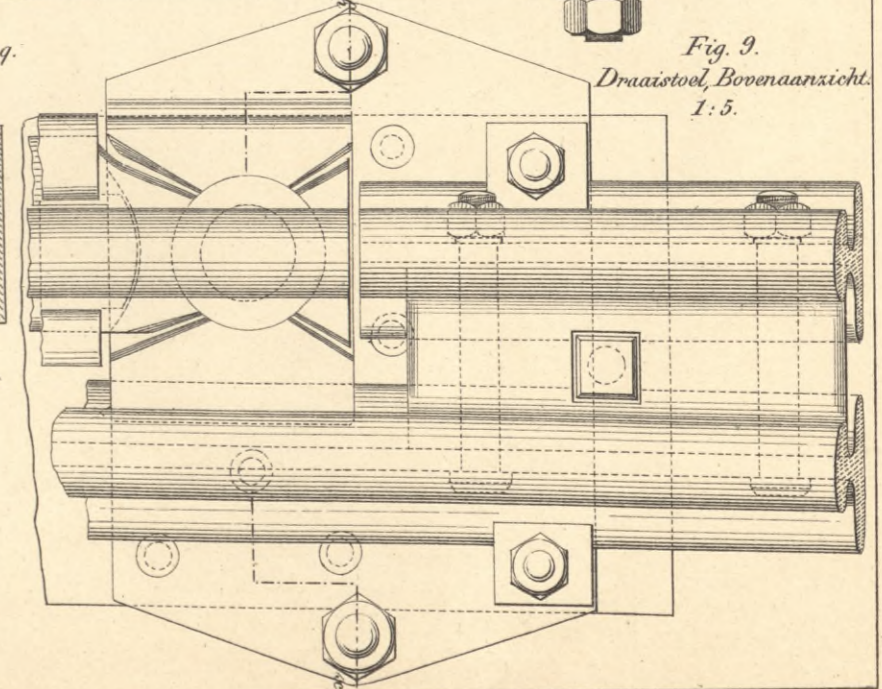
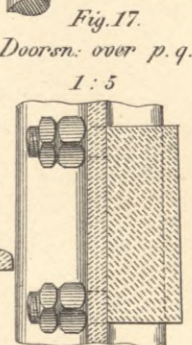
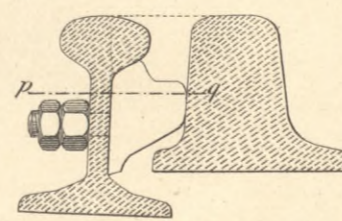
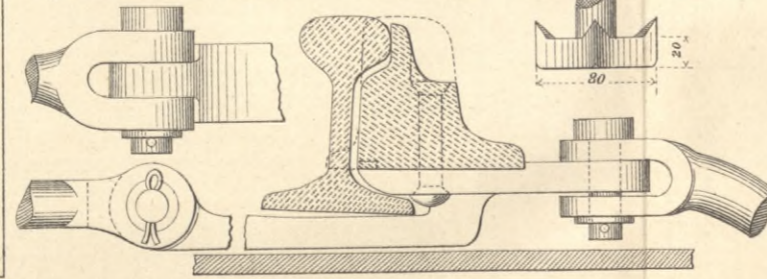
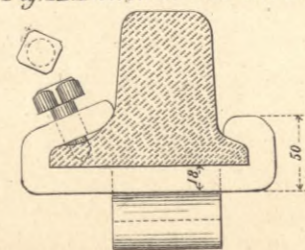
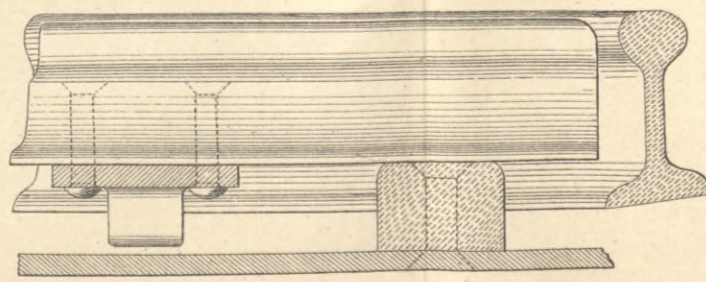
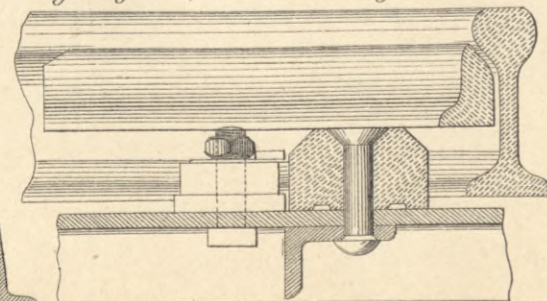
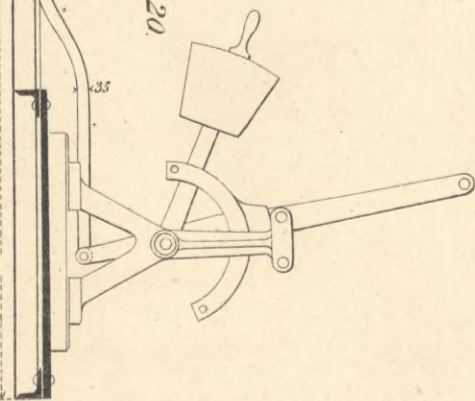


Fig. 7. Glijdstoel, Zijaanzicht 1:5.

Fig. 8. Glijdstoel, Doorsnede over g.h. 1:5.

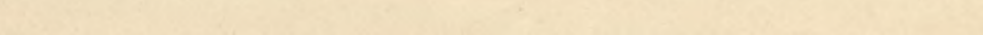
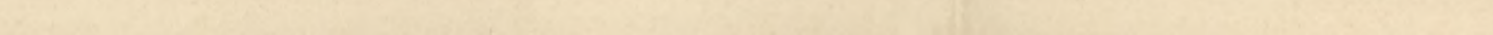
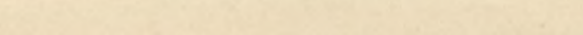
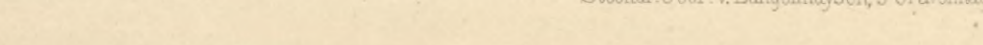
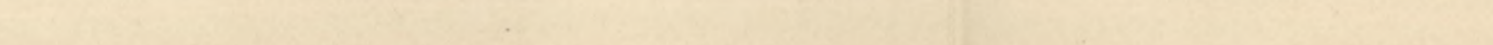
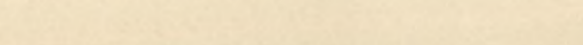
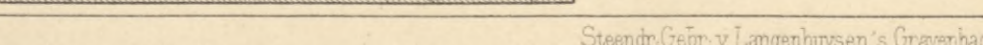
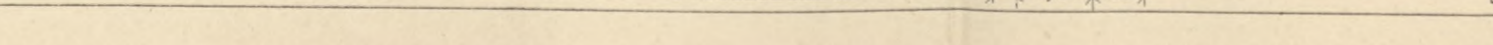
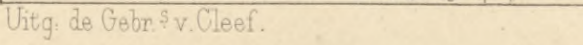
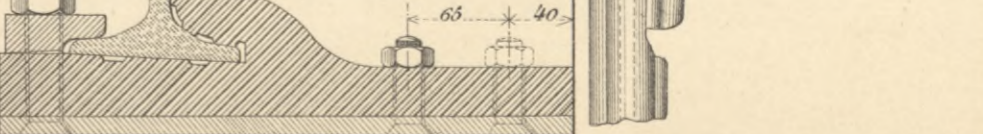
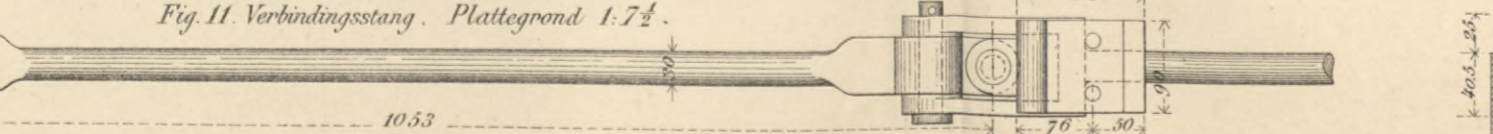
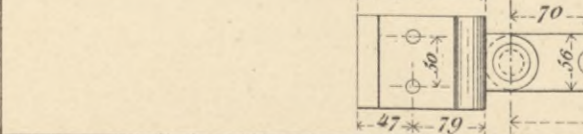
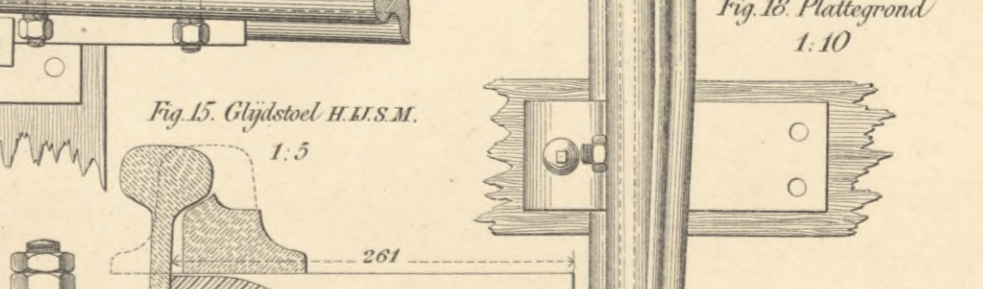
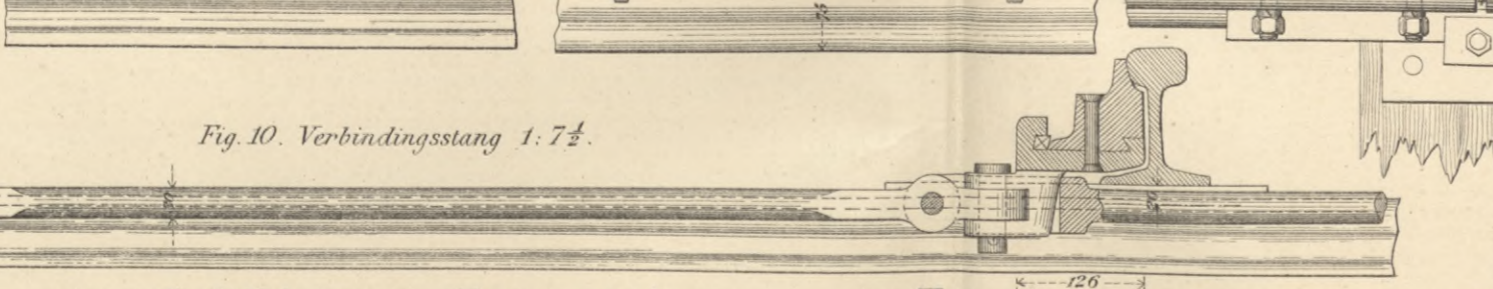
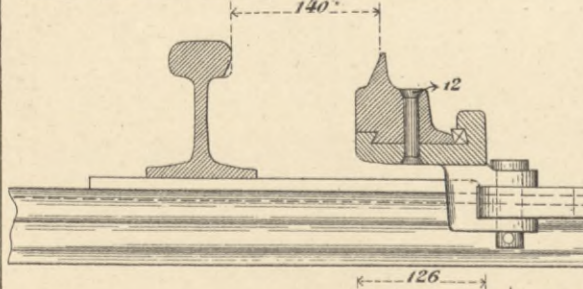
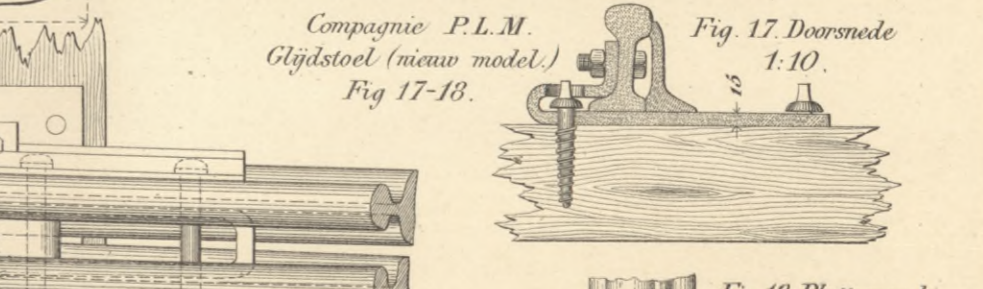
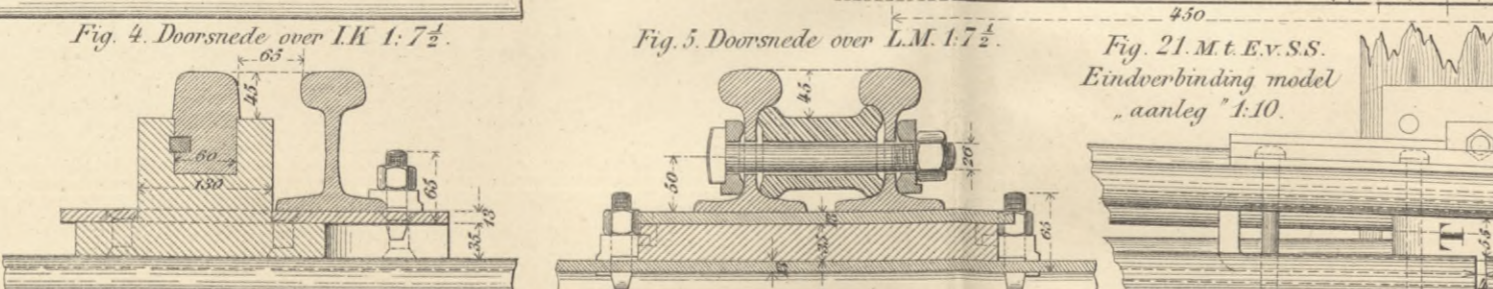
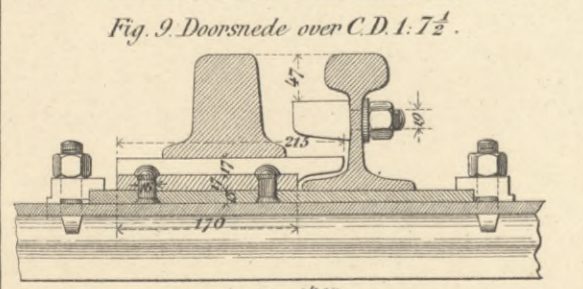
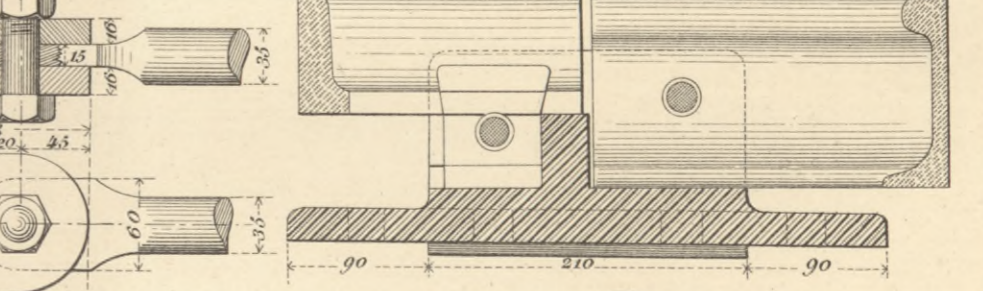
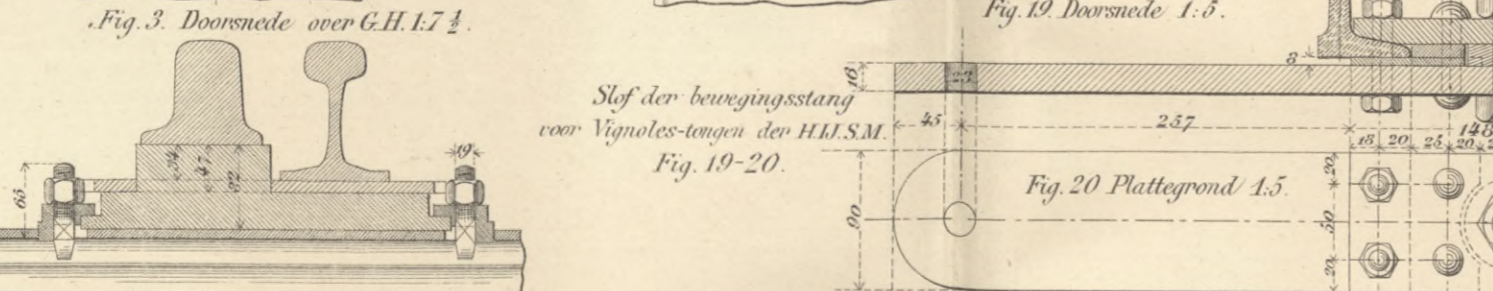
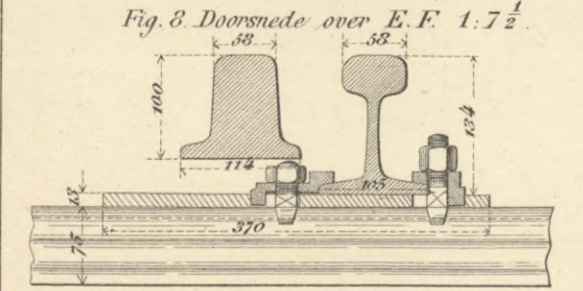
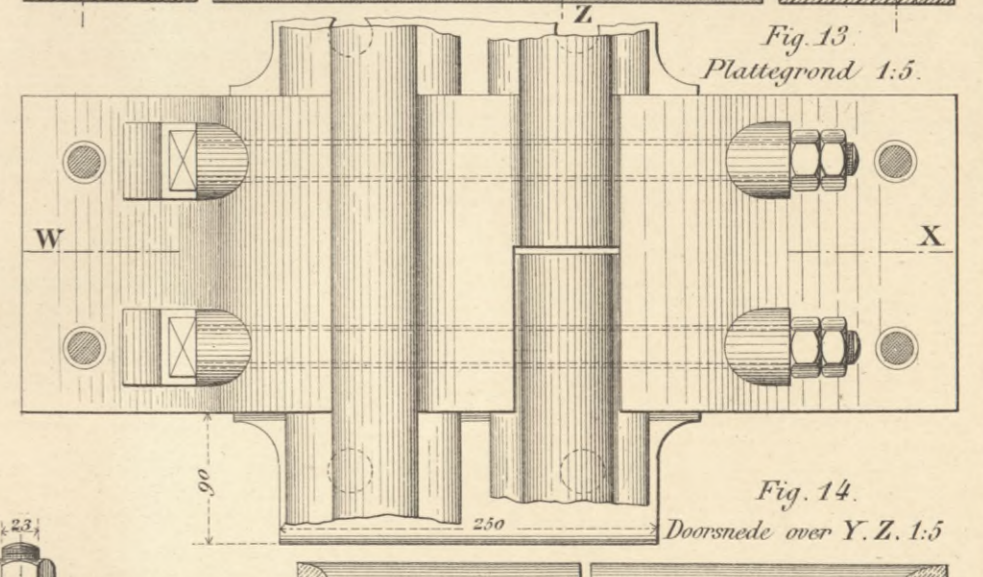
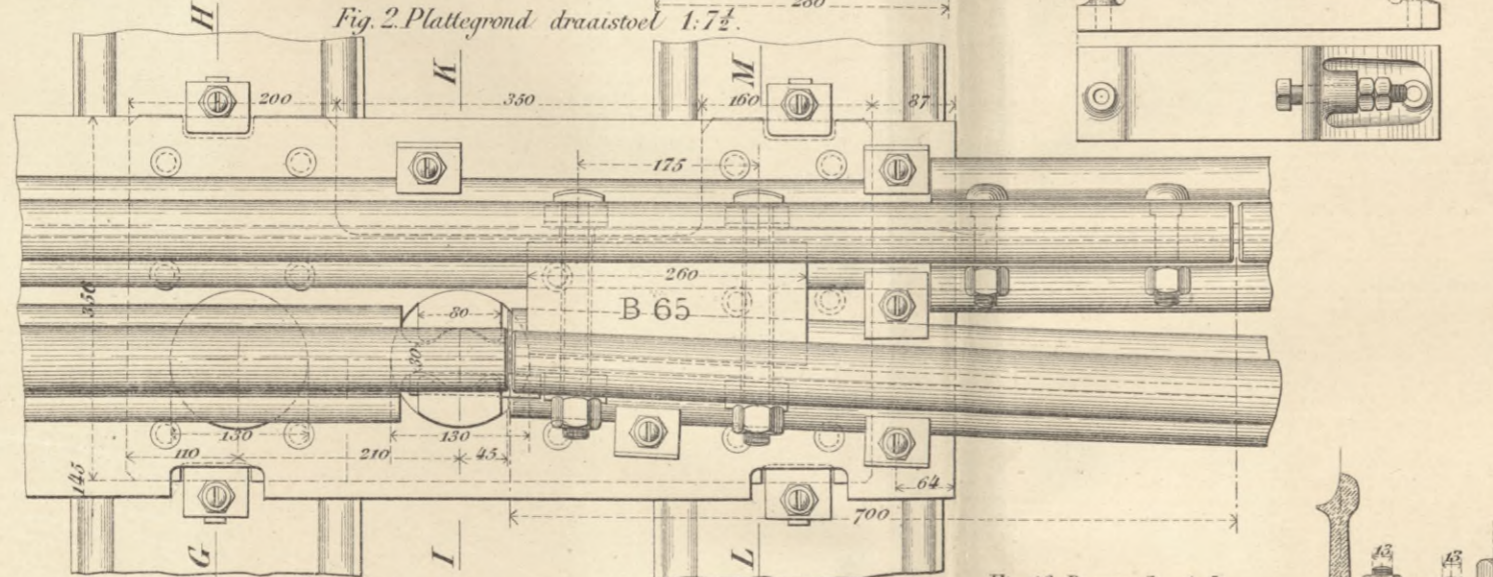
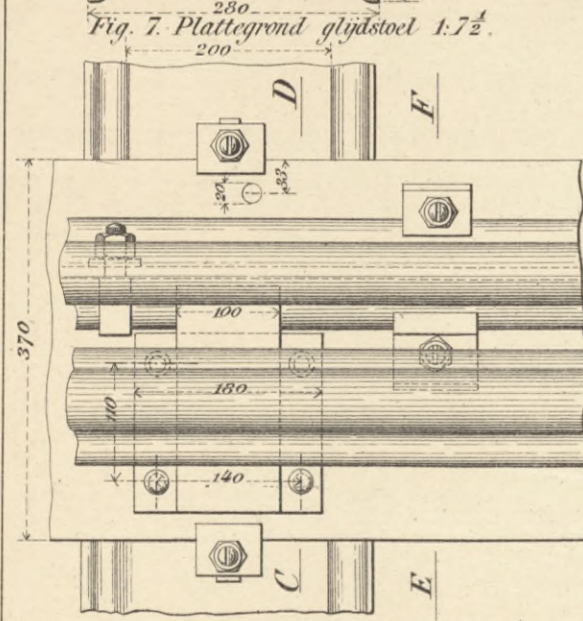
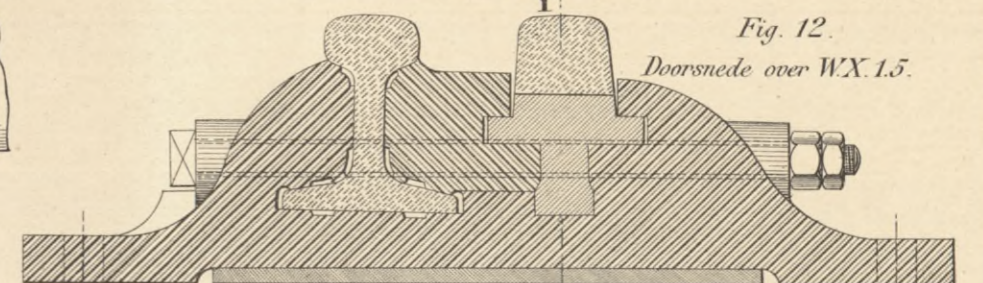
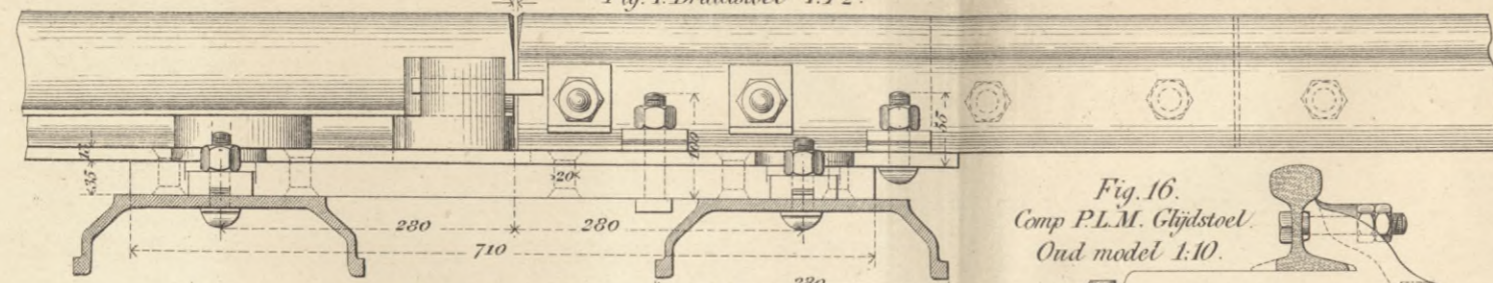
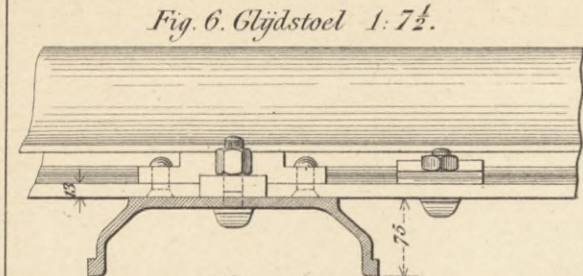
Fig. 14. Doorsnede over glijdstoel en verbindingsstang. 1:5.

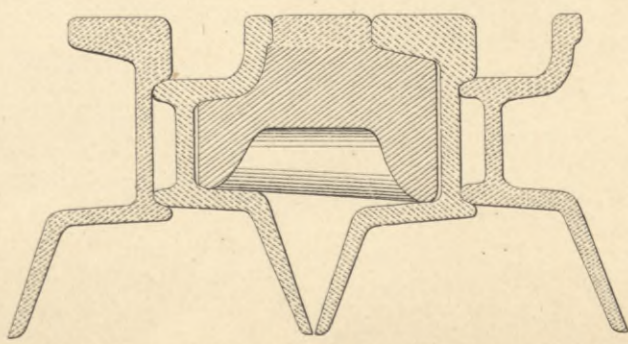
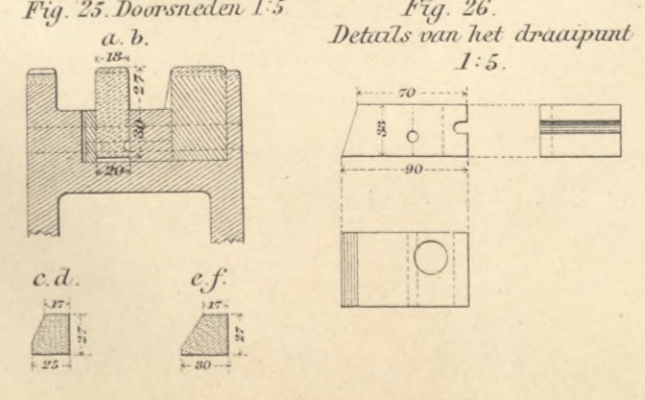
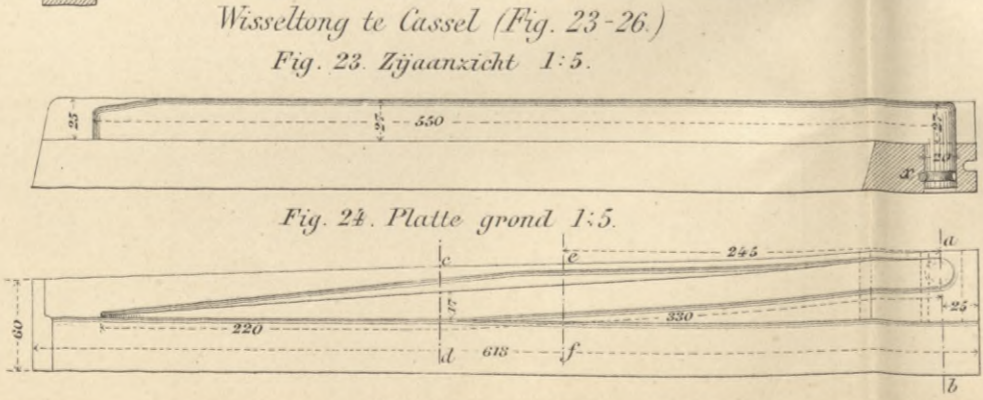
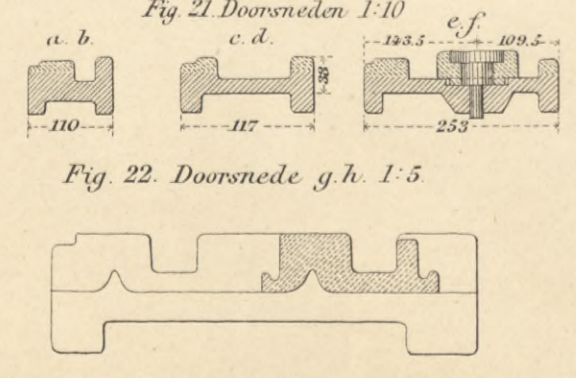
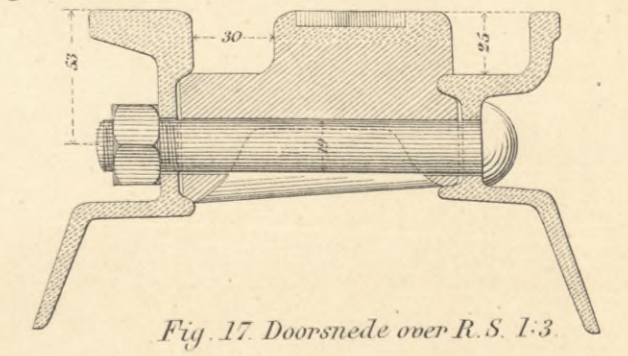
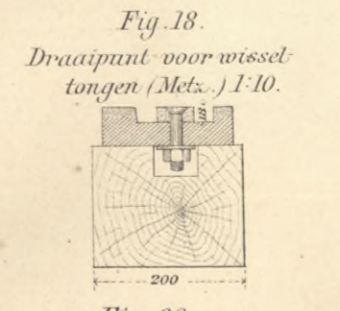
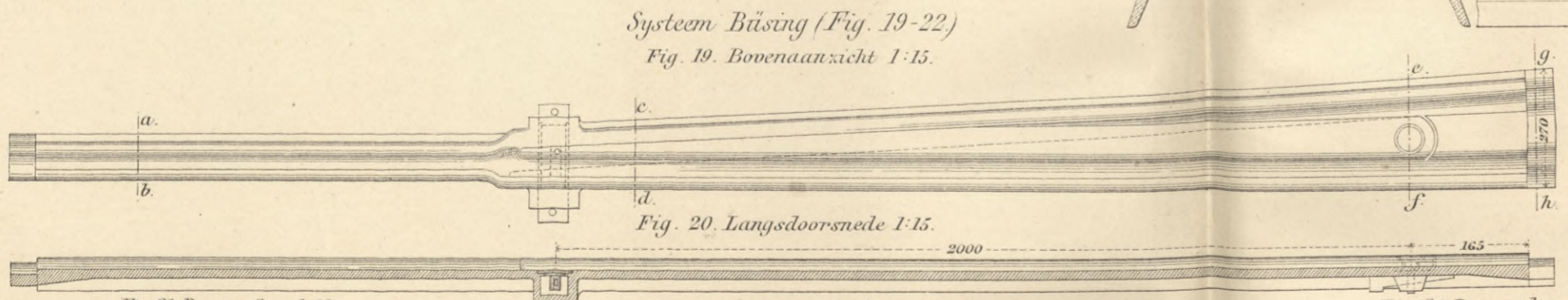
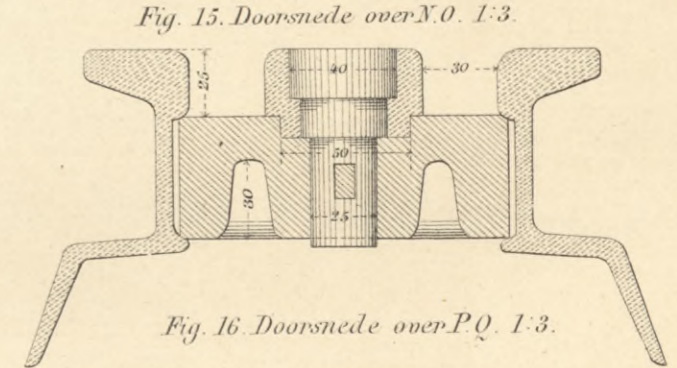
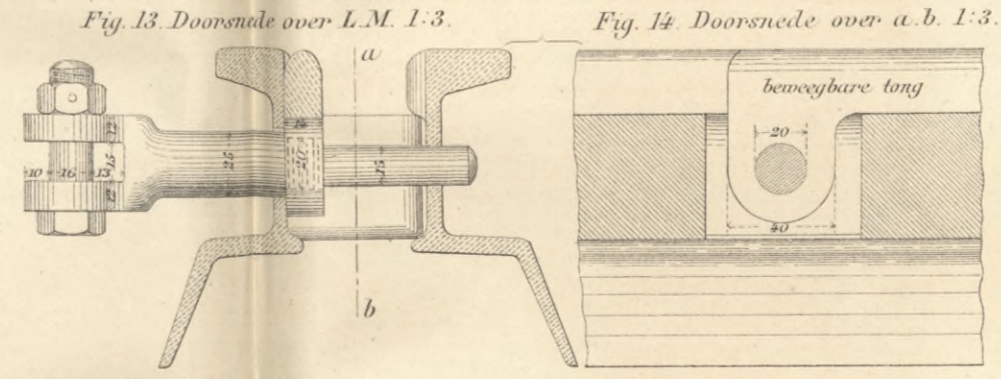
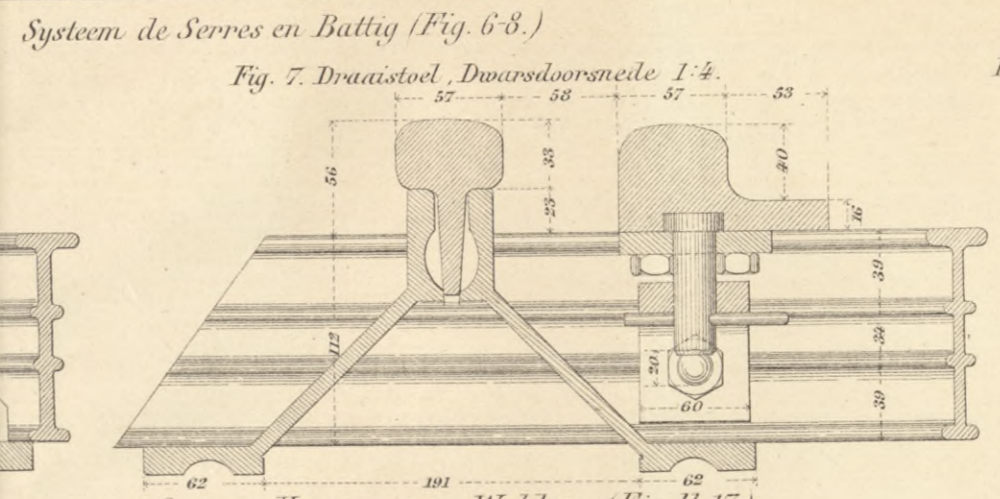
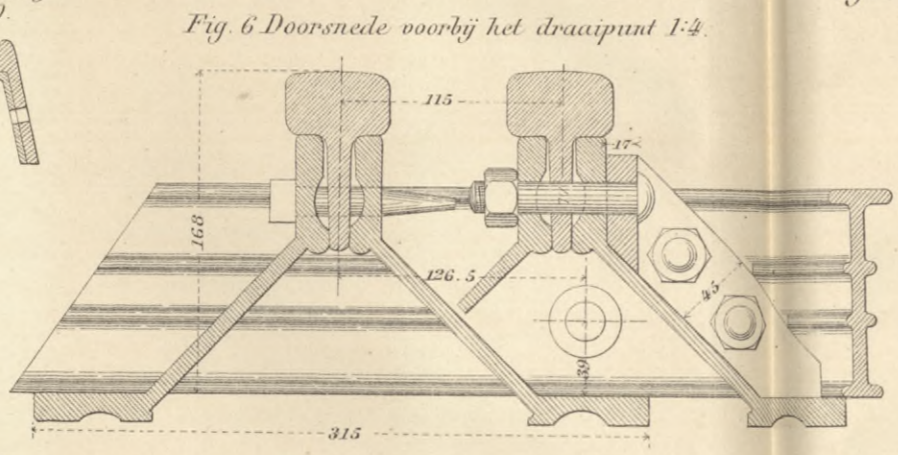
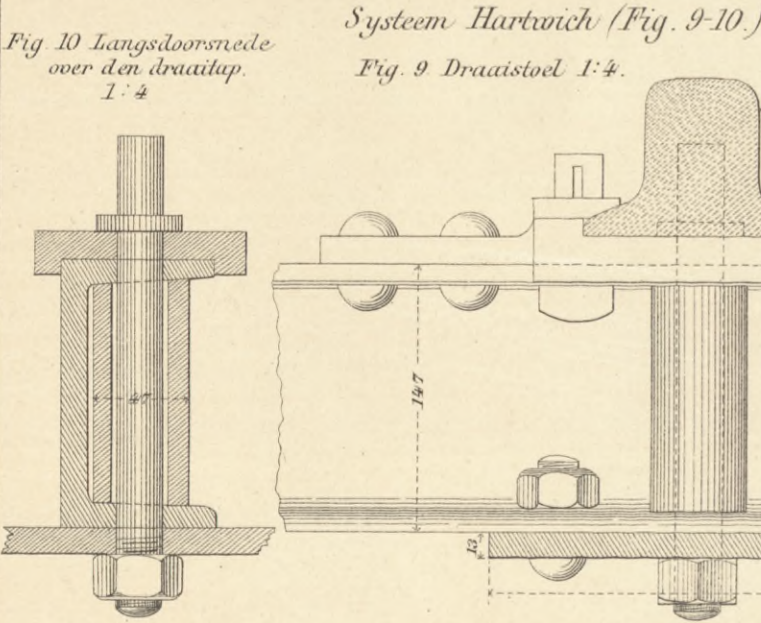
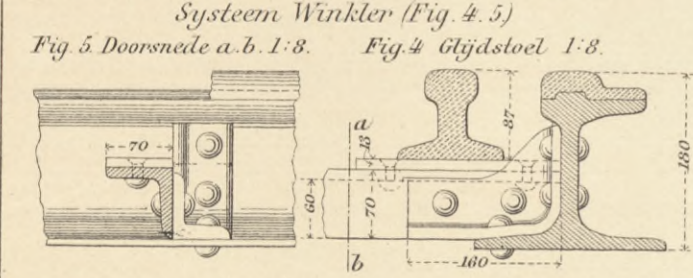
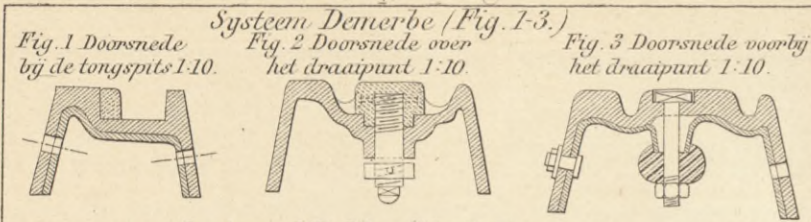
Fig. 12. Doorsnede over r.s. 1:5.

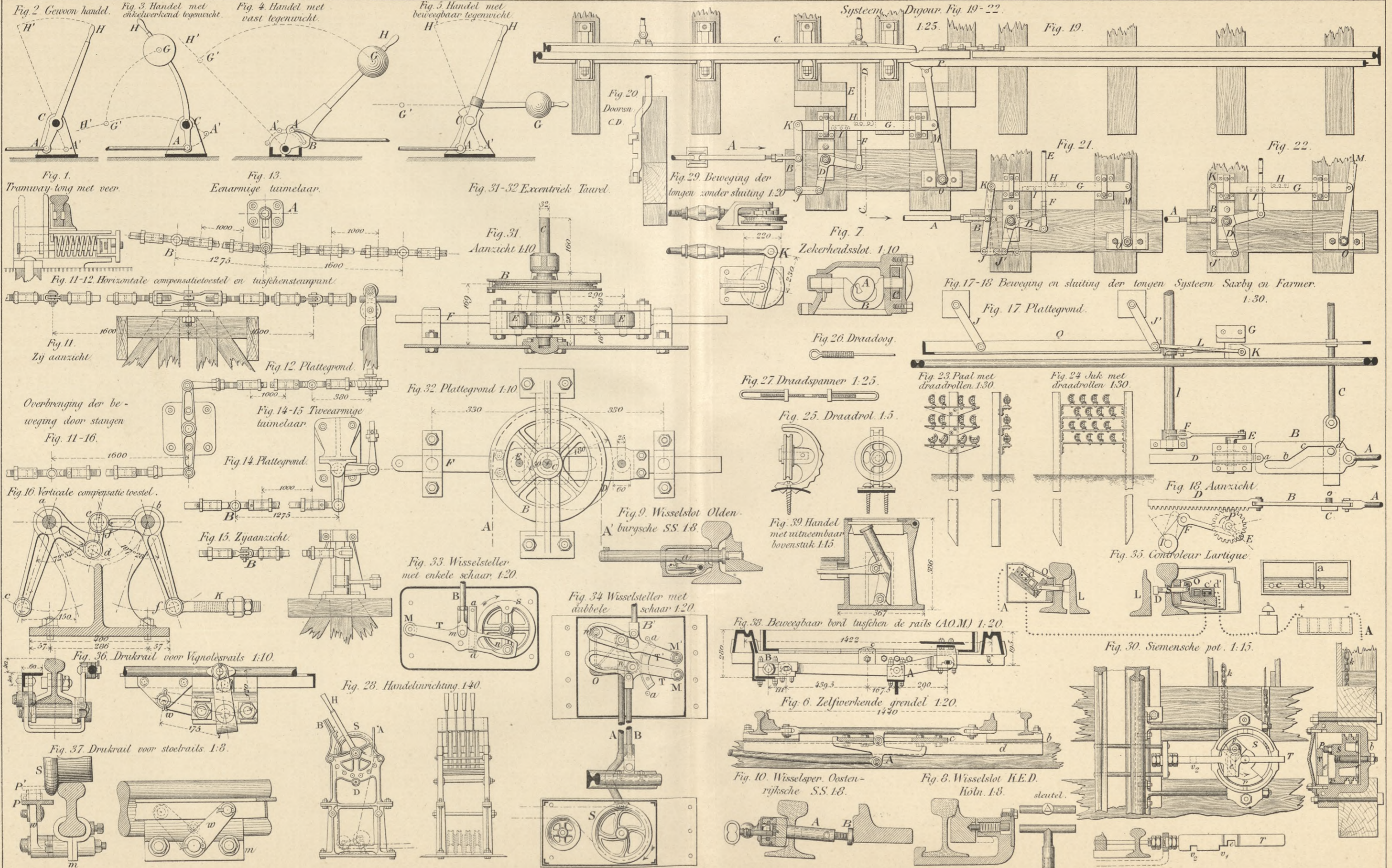


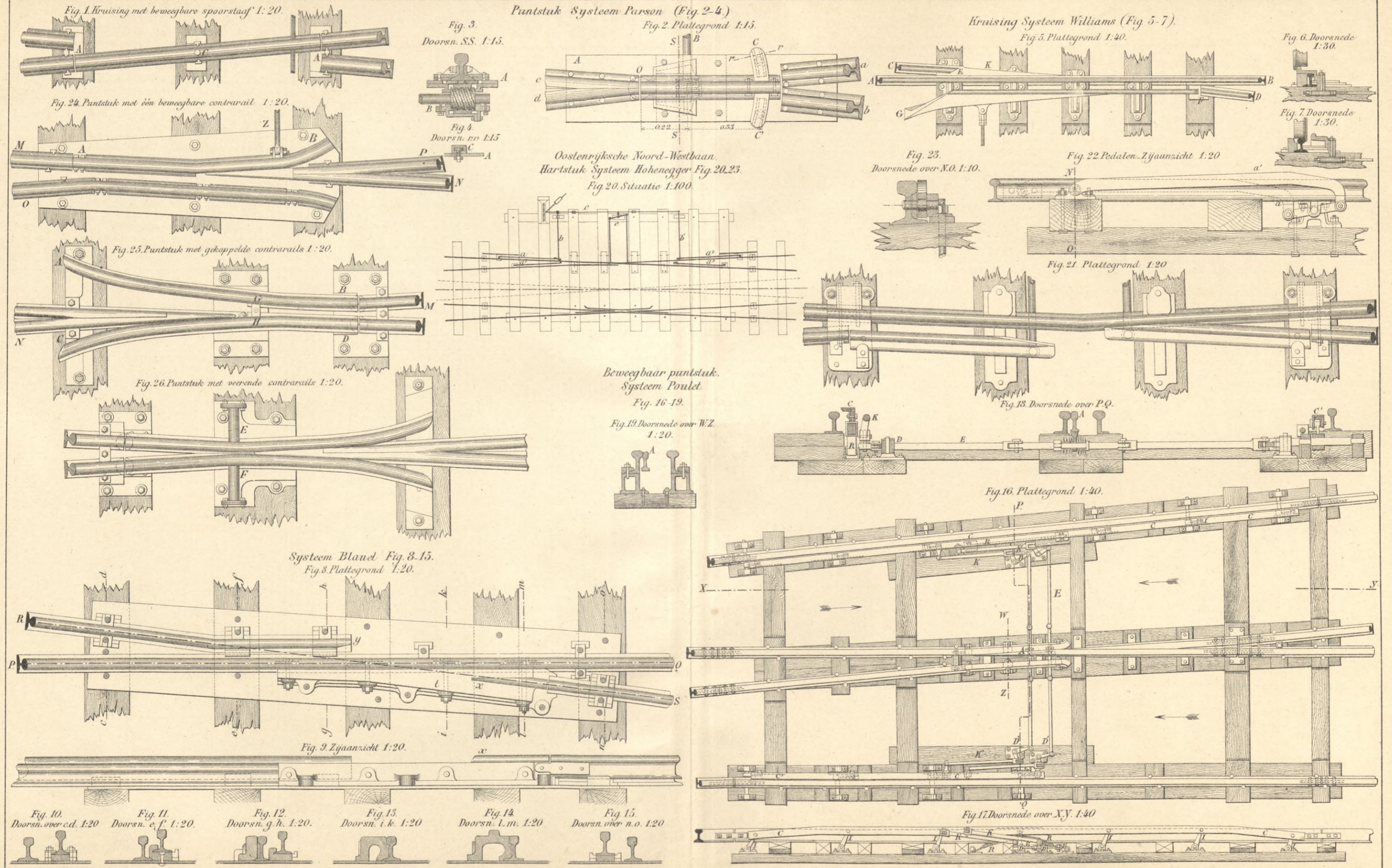
Pruisische Staatsspoorwegen (Fig. 1-11.)
Fig. 1. Draaistoel 1:7 1/2.

Draaistoel H.H.S.M. (Fig. 12-14.)

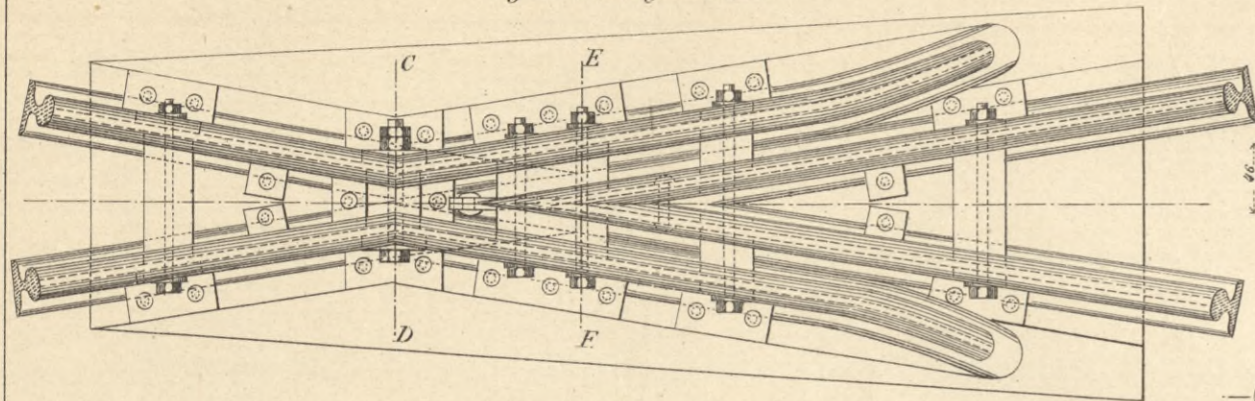








Puntstuk uit rails (Fig. 1^a-1^c).
Fig. 1^a Platte grond 1:15.



Doorsnede over CD 1:5.

Fig. 1^b

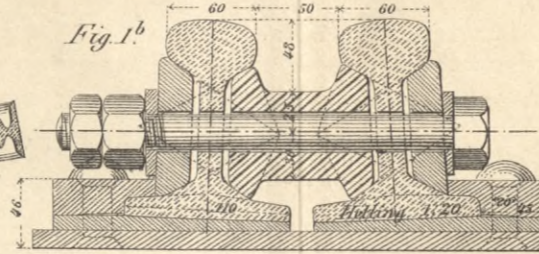
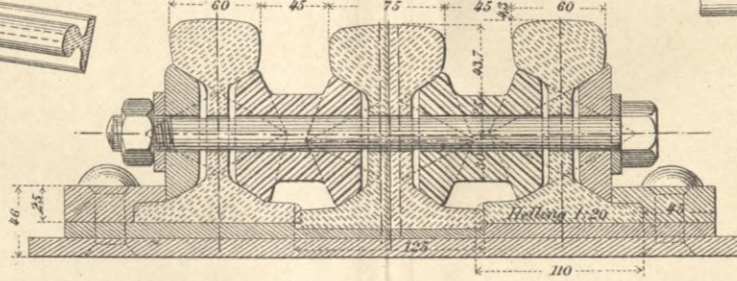


Fig. 1^c Doorsnede over E.F. 1:5.



Hartstuk uit rails (Fig. 2^a-2^b).
Fig. 2^a Platte grond 1:15.

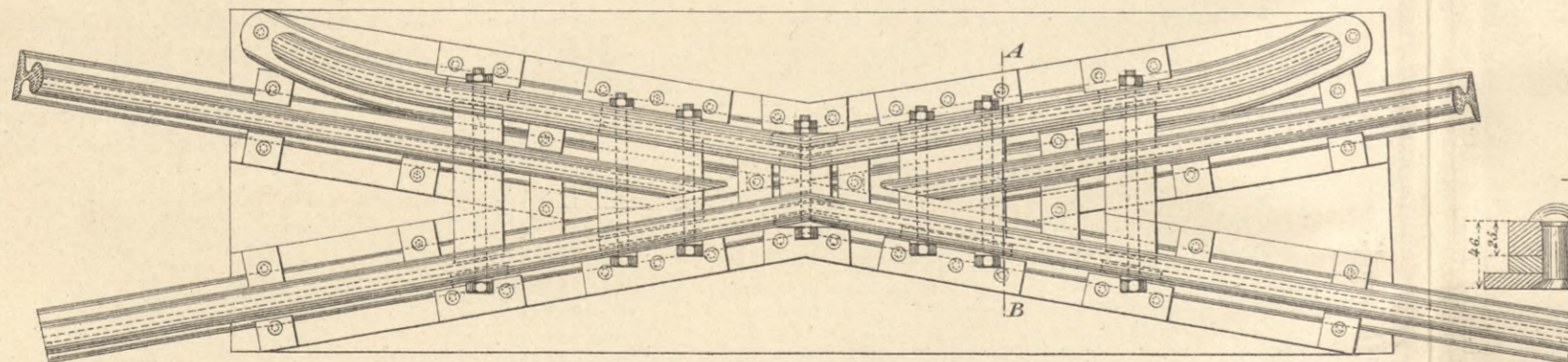
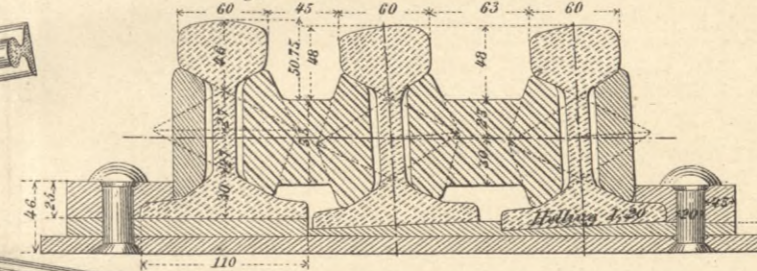


Fig. 2^b Doorsnede over AB 1:5.



Puntstuk voor tramwegen. System Heusinger von Waldegg. Fig. 6^a-6^e.
Fig. 6^a Platte grond 1:15.

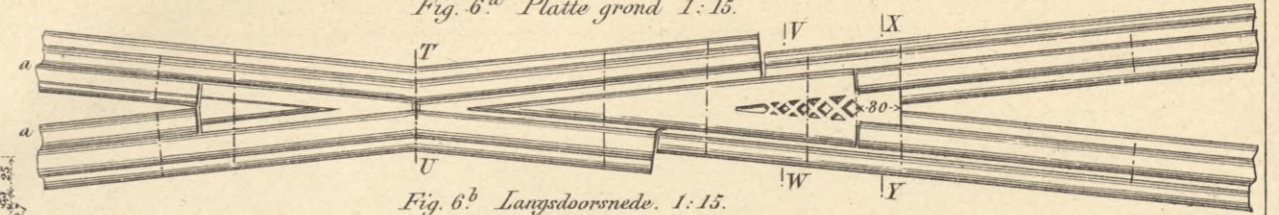


Fig. 6^b Langsdoorsnede. 1:15.

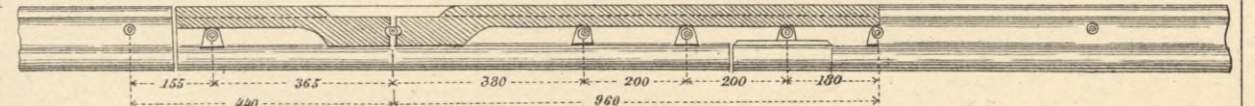


Fig. 6^c Doorsnede over TU. 1:5.

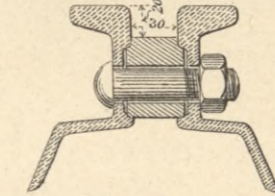


Fig. 6^d Doorsnede VW. 1:5.

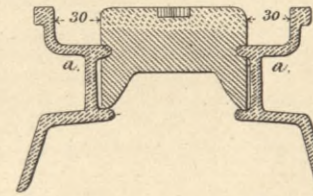


Fig. 6^e Doorsnede XY. 1:5.

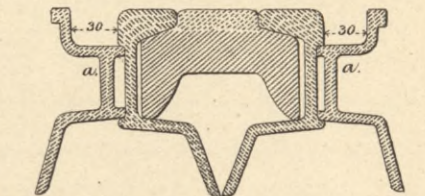
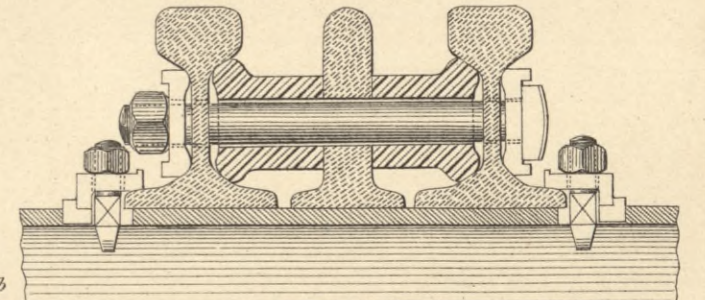


Fig. 4^c Doorsnede over cd. 1:5.



Puntstuk uit rails met stalen spits (Fig. 4^a-4^c).
Fig. 4^a Platte grond 1:15.

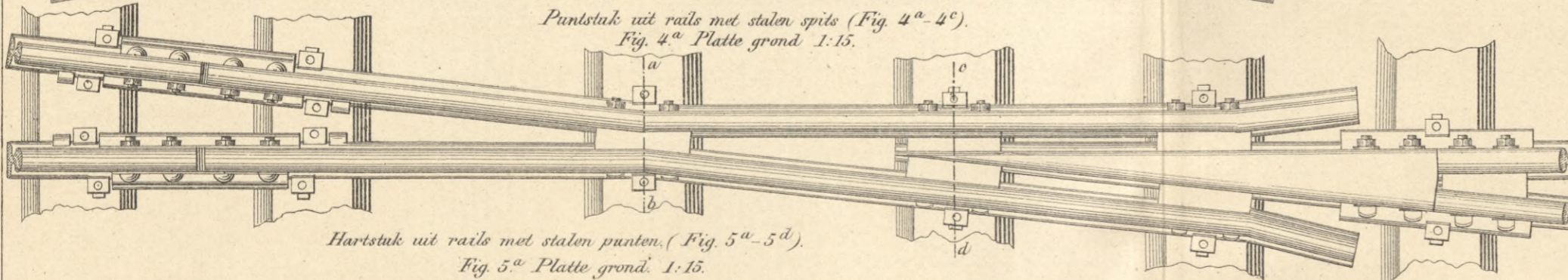


Fig. 4^b Doorsnede over a b. 1:5.

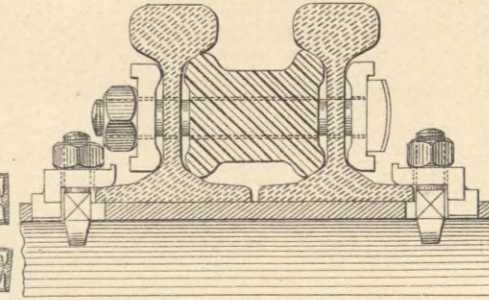
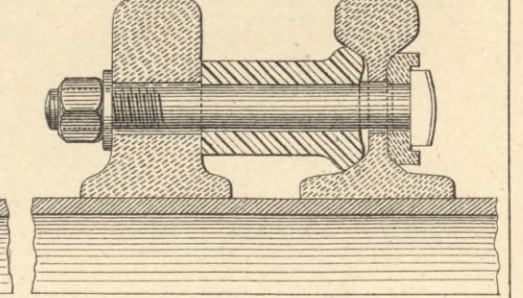


Fig. 5^b Doorsnede over ef. 1:5.



Hartstuk uit rails met stalen punten. (Fig. 5^a-5^d).
Fig. 5^a Platte grond. 1:15.

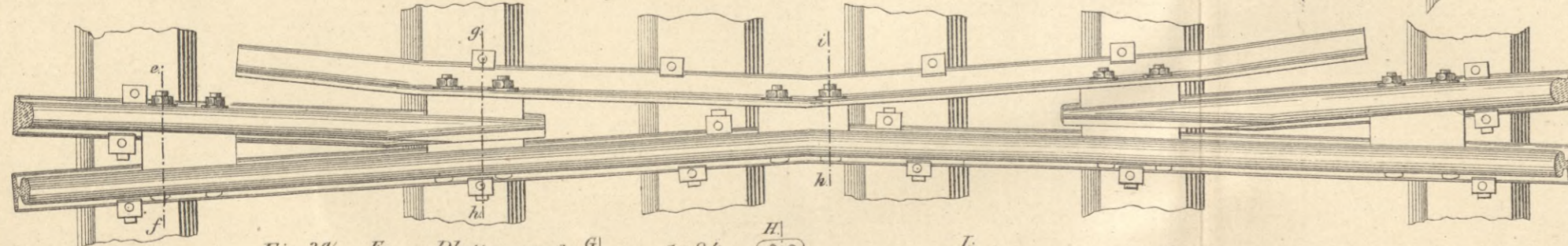


Fig. 5^c Doorsnede over gh. 1:5.

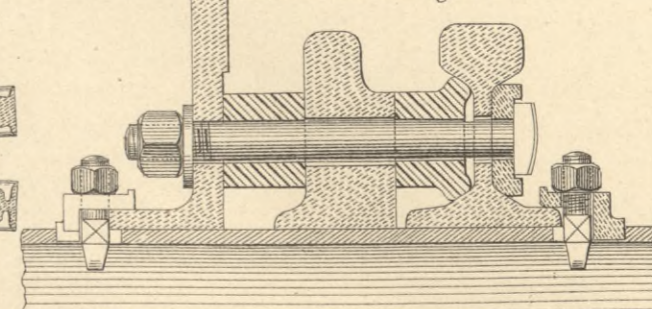


Fig. 5^d Doorsnede over ik. 1:5.

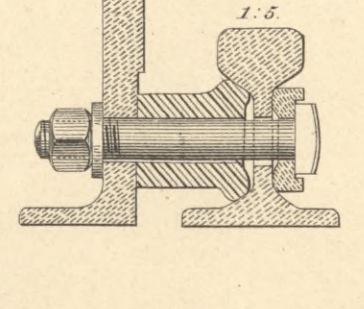
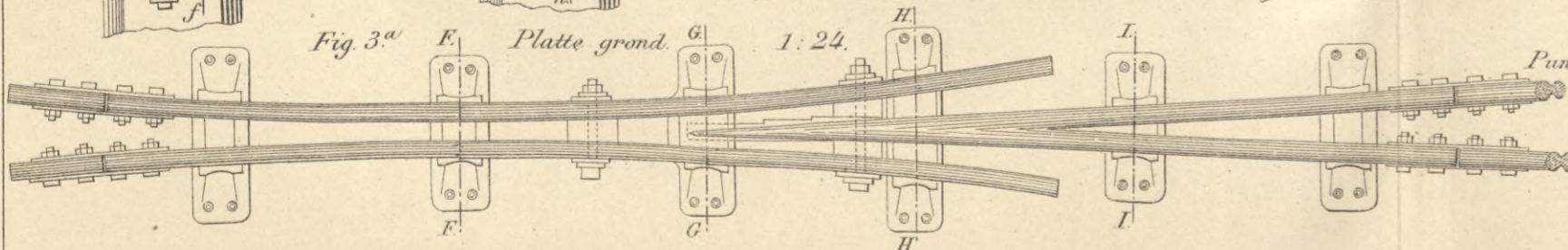


Fig. 3^a Platte grond. 1:24.



Puntstuk van den London and North Western Railway. (Fig. 3^a-3^e).

Fig. 3^b Doorsn. over FF. 1:16.



Fig. 3^c Doorsn. over GG. 1:16.



Fig. 3^d Doorsn. over HH. 1:16.



Fig. 3^e Doorsn. over II. 1:16.



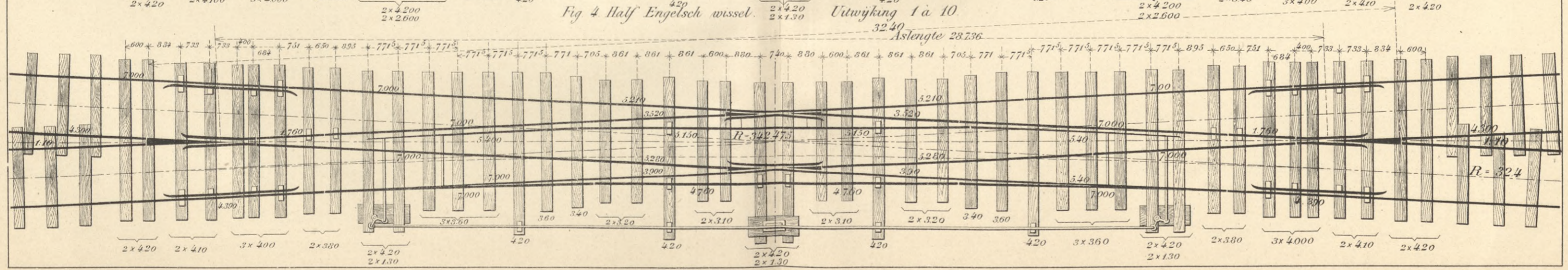
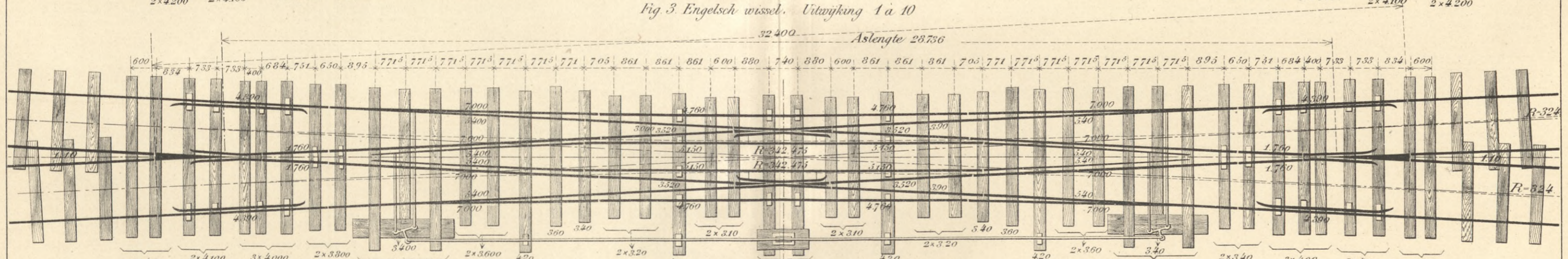
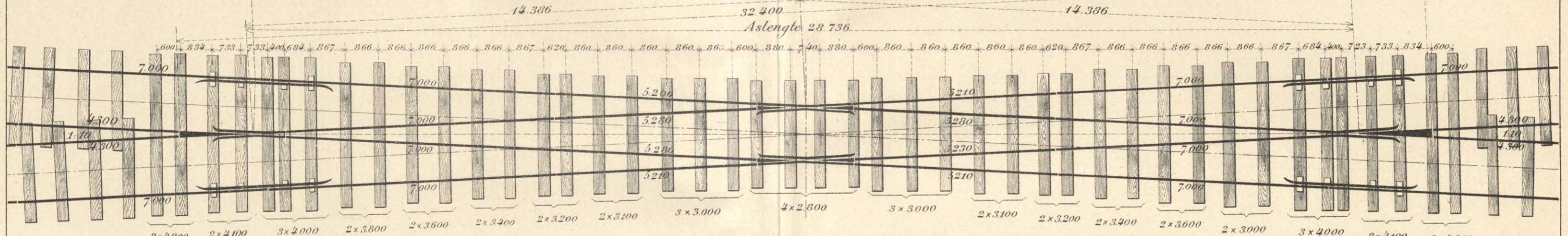
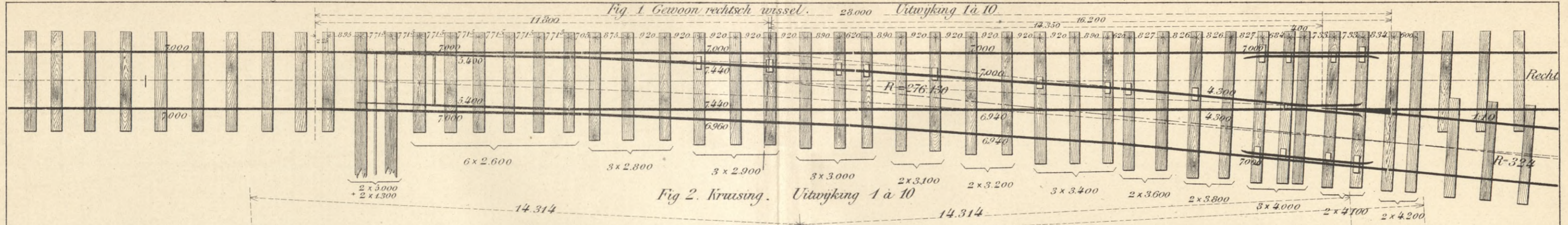


Fig. 2^a Langsdoorsnede 1:20.

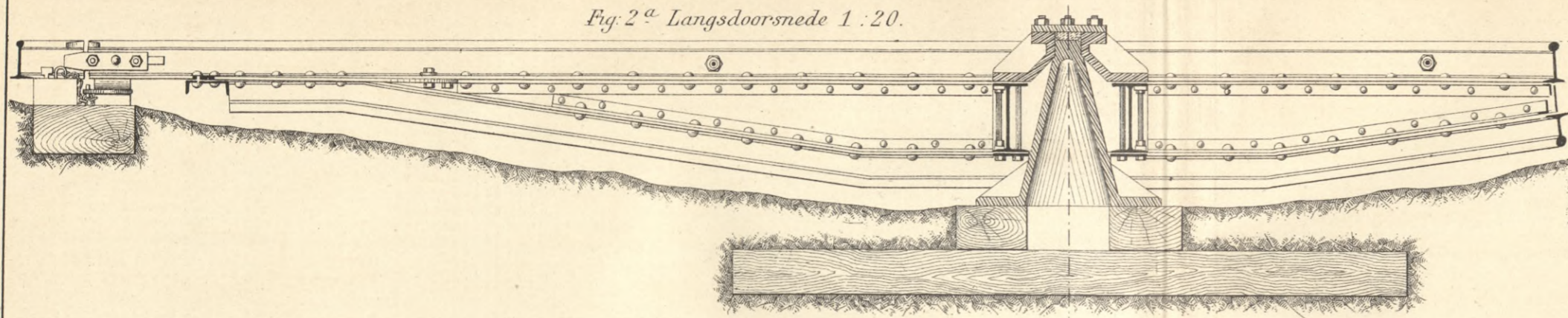


Fig. 2^b Dwars-
doorsnede 1:20.

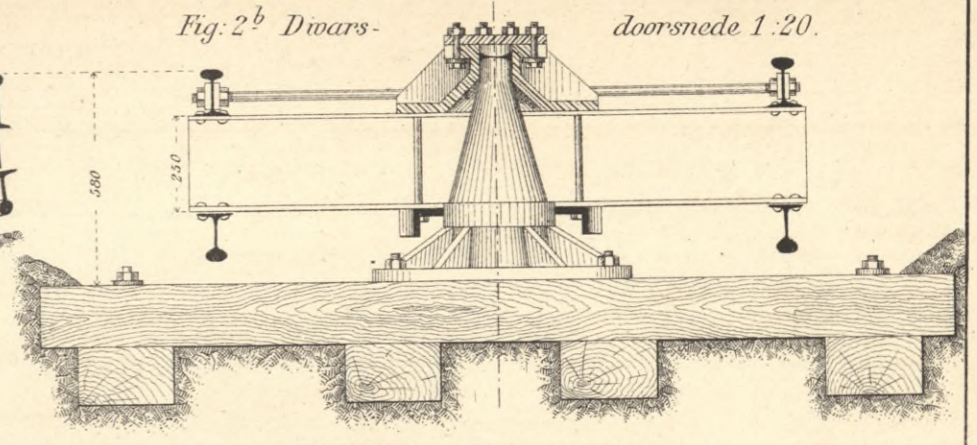
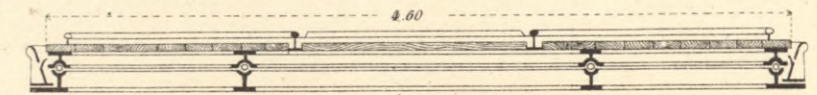


Fig. 1^a Dwarsdoorsnede 1:46.



Draaischijf voor wagens der
Oldenburgsche S.S. Fig. 2^{a-c}.

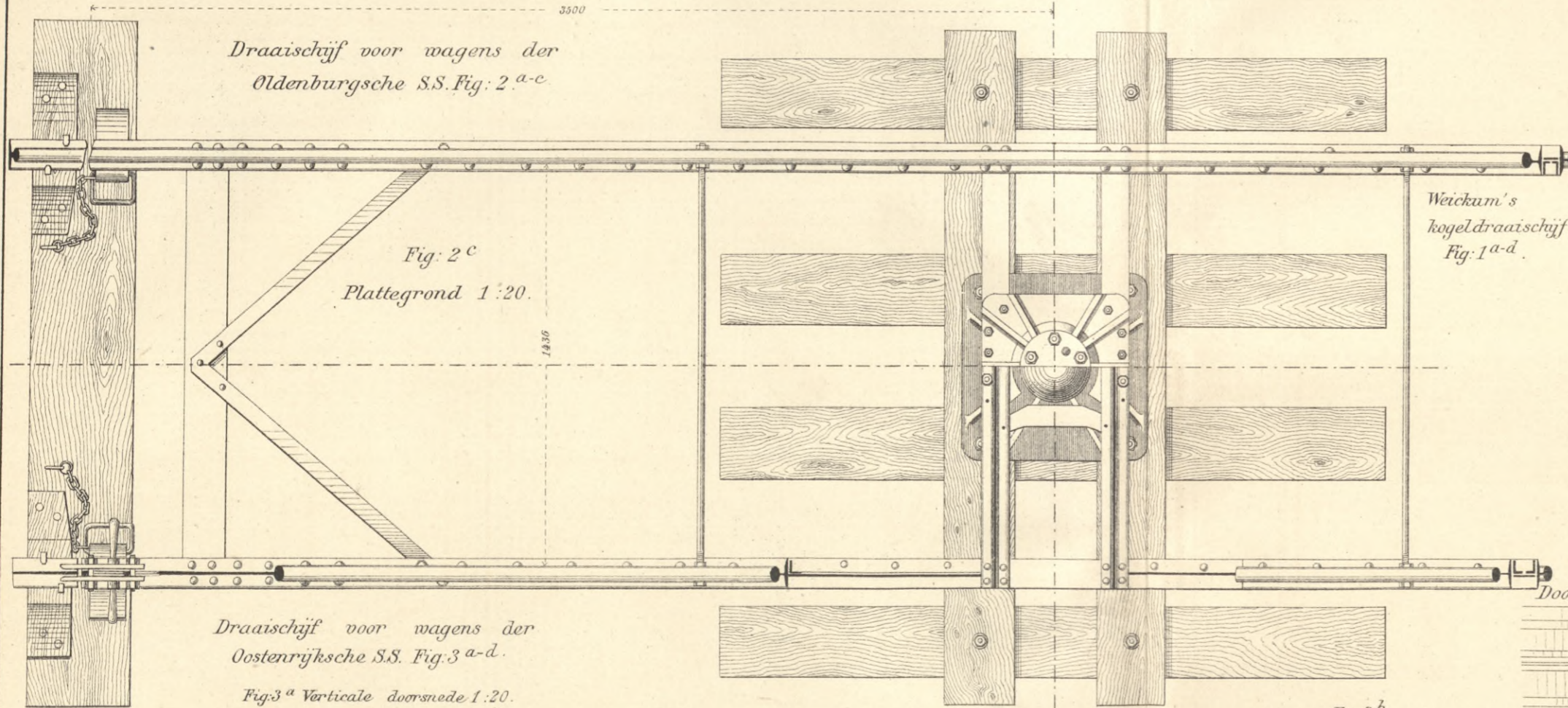
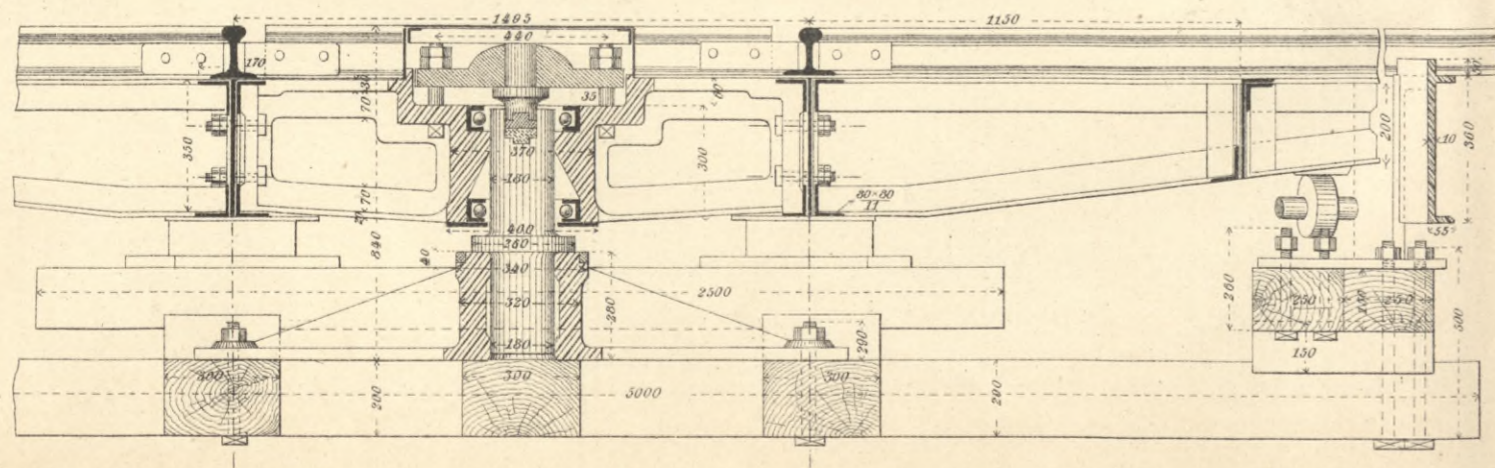


Fig. 2^c
Plattegrond 1:20.

Draaischijf voor wagens der
Oostenrijksche S.S. Fig. 3^{a-d}.

Fig. 3^a Verticale doorsnede 1:20.



Weickum's
kogeldraaischijf
Fig. 1^{a-d}.

Fig. 1^c
Doorsnede 1:15.

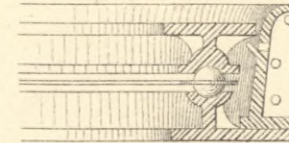


Fig. 1^b
Plattegrond.
1:46.

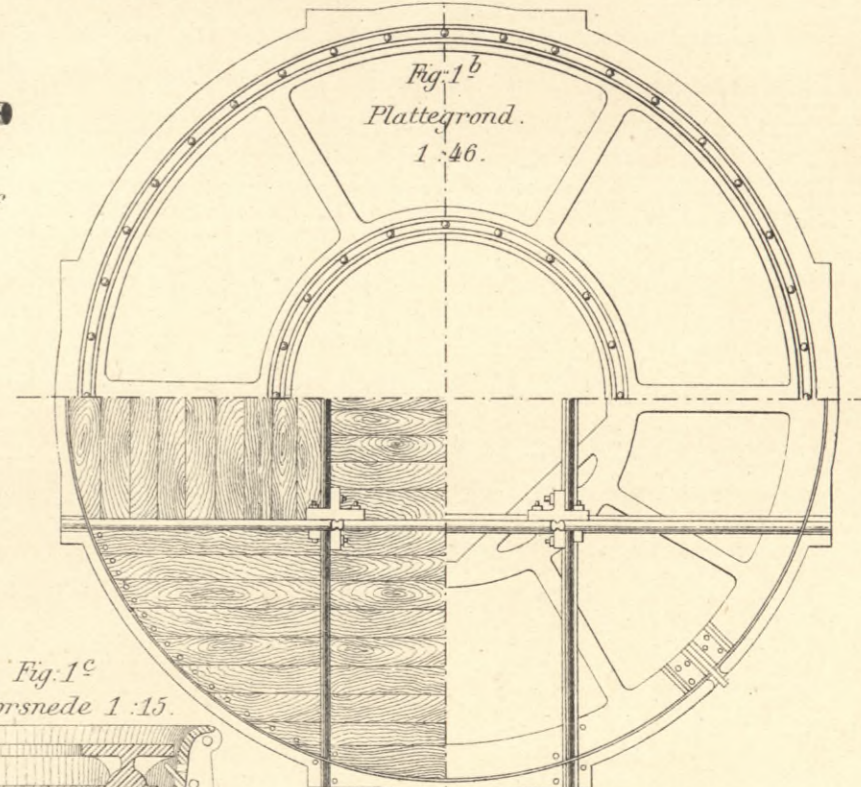


Fig. 1^d Details der kogels 1:15.

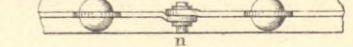


Fig. 3^b
Steunrol
Doorsnede 1:10.

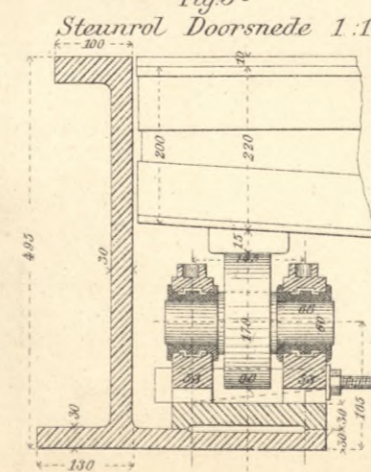


Fig. 3^c Steunrol
Zijaanzicht 1:10.

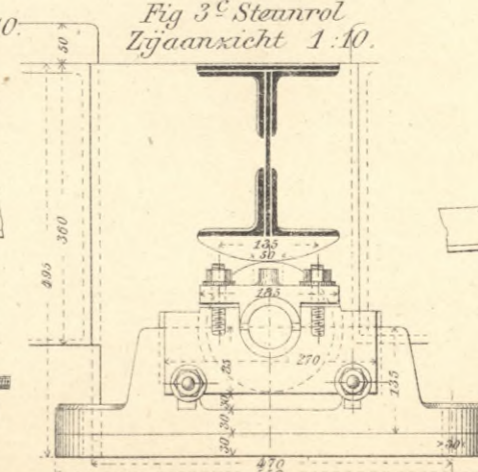
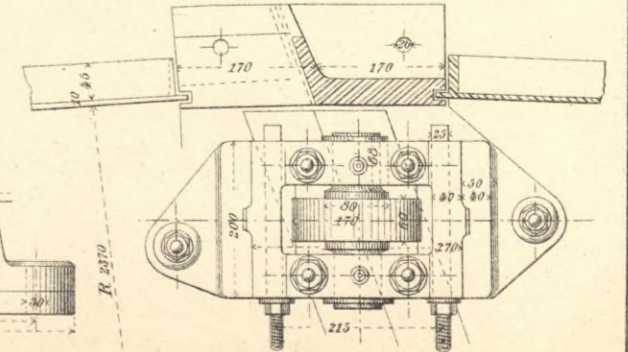
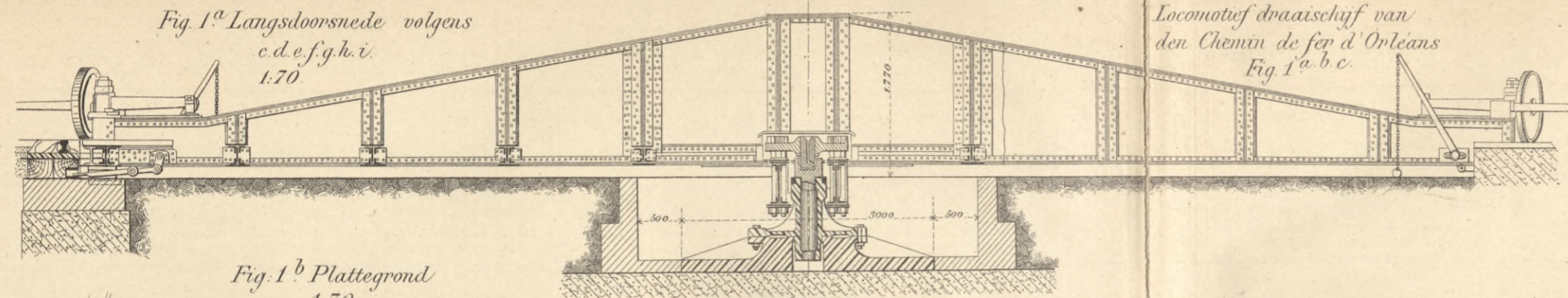


Fig. 3^d
Steunrol
Bovenaanzicht 1:10.





Locomotief draaischijf van den Chemin de fer d'Orléans Fig. 1 a. b. c.

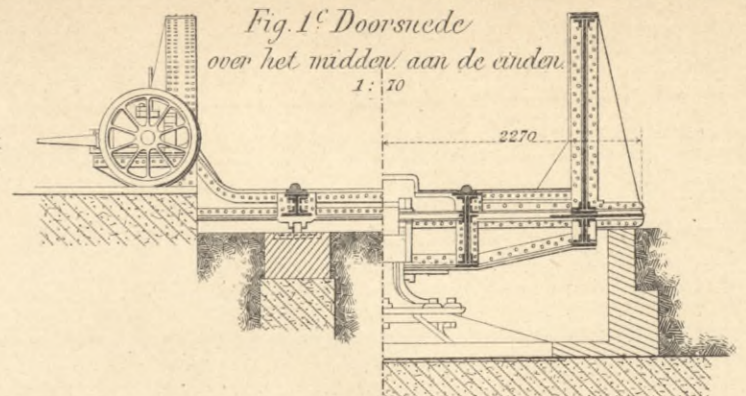
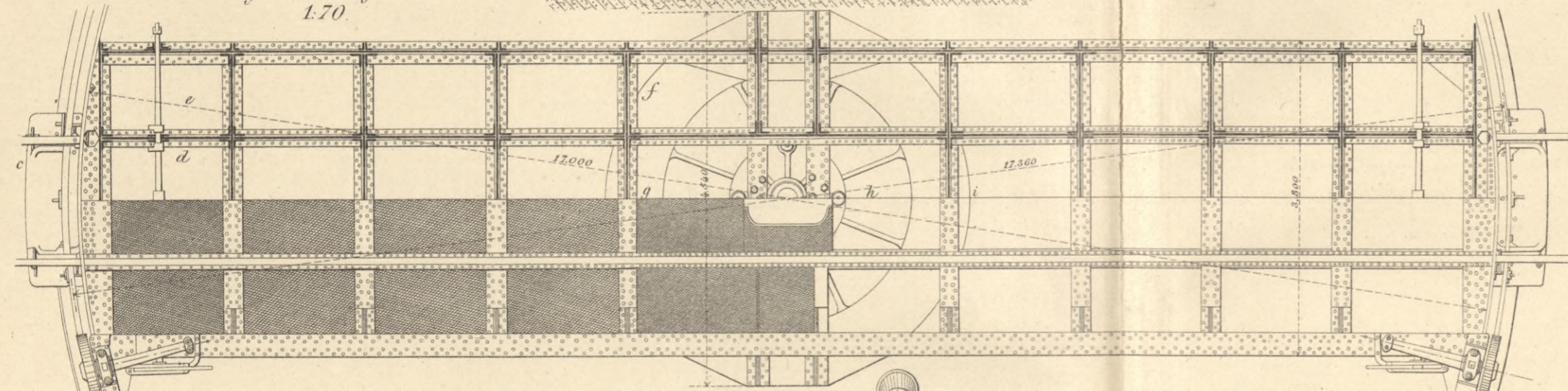


Fig. 1 b Plattegrond 1:70.



Locomotief draaischijf der Pruisische S.S. Fig. 2 a-g.

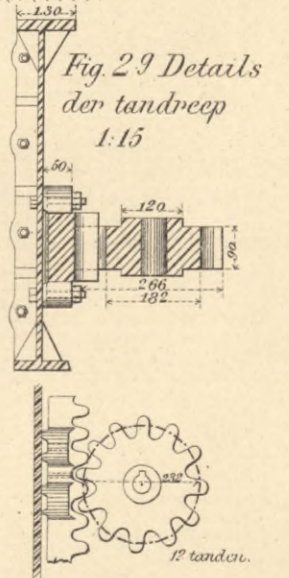


Fig. 2 e Doorsnede AB.

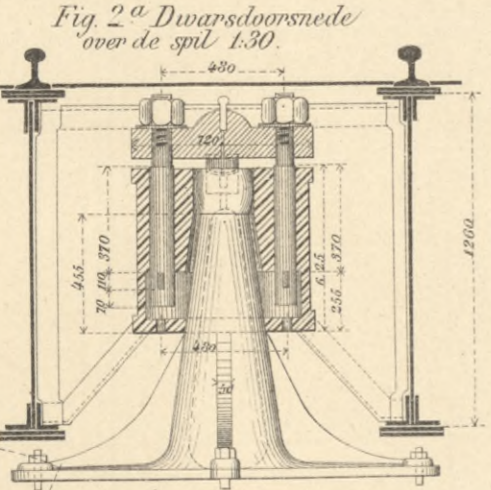
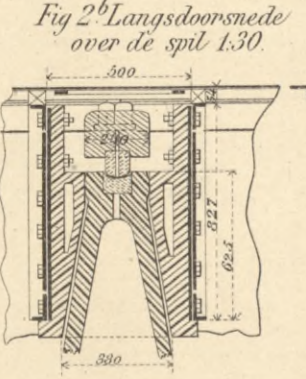
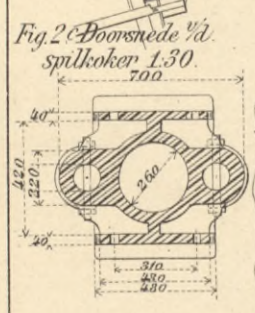
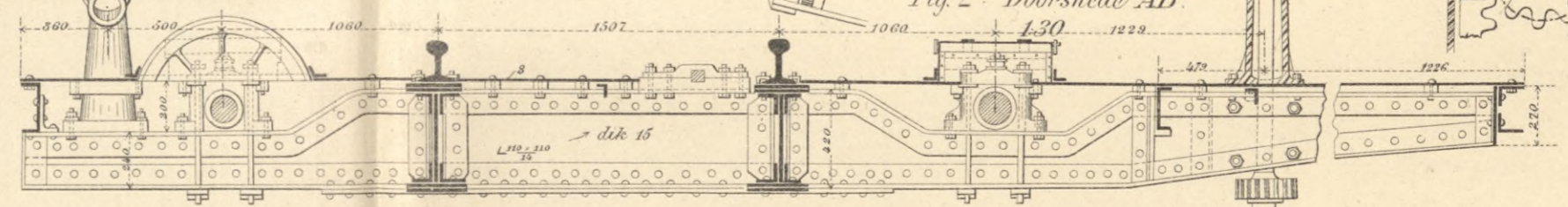
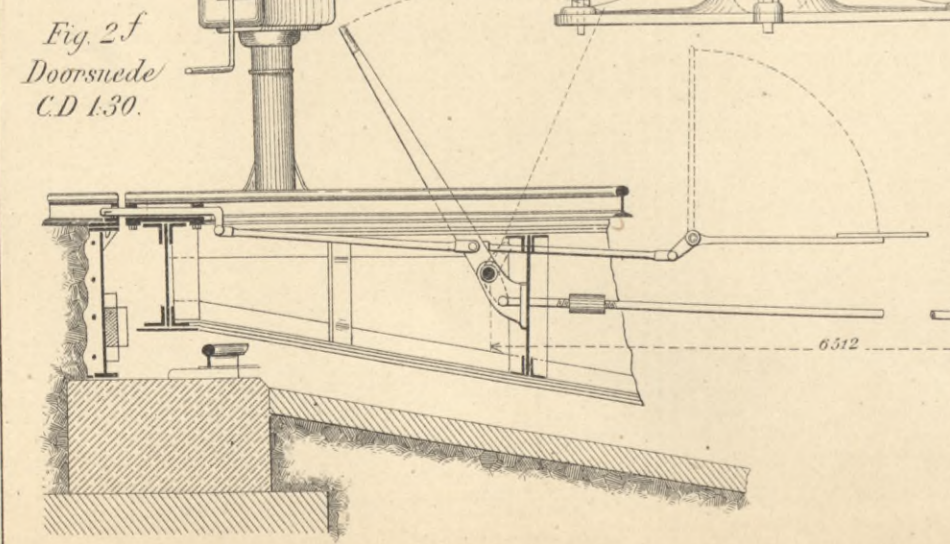
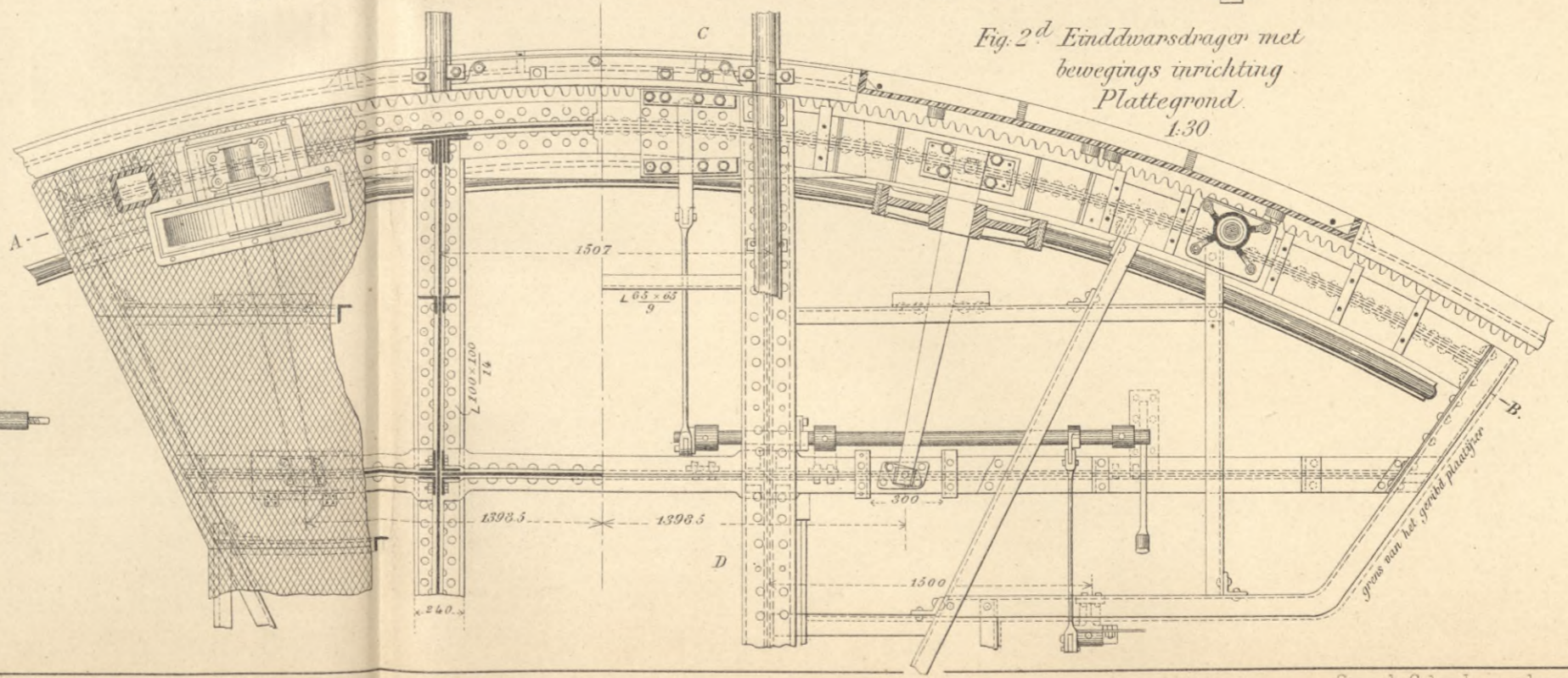


Fig. 2 d Einddwarsdrager met bewegings inrichting Plattegrond. 1:30.



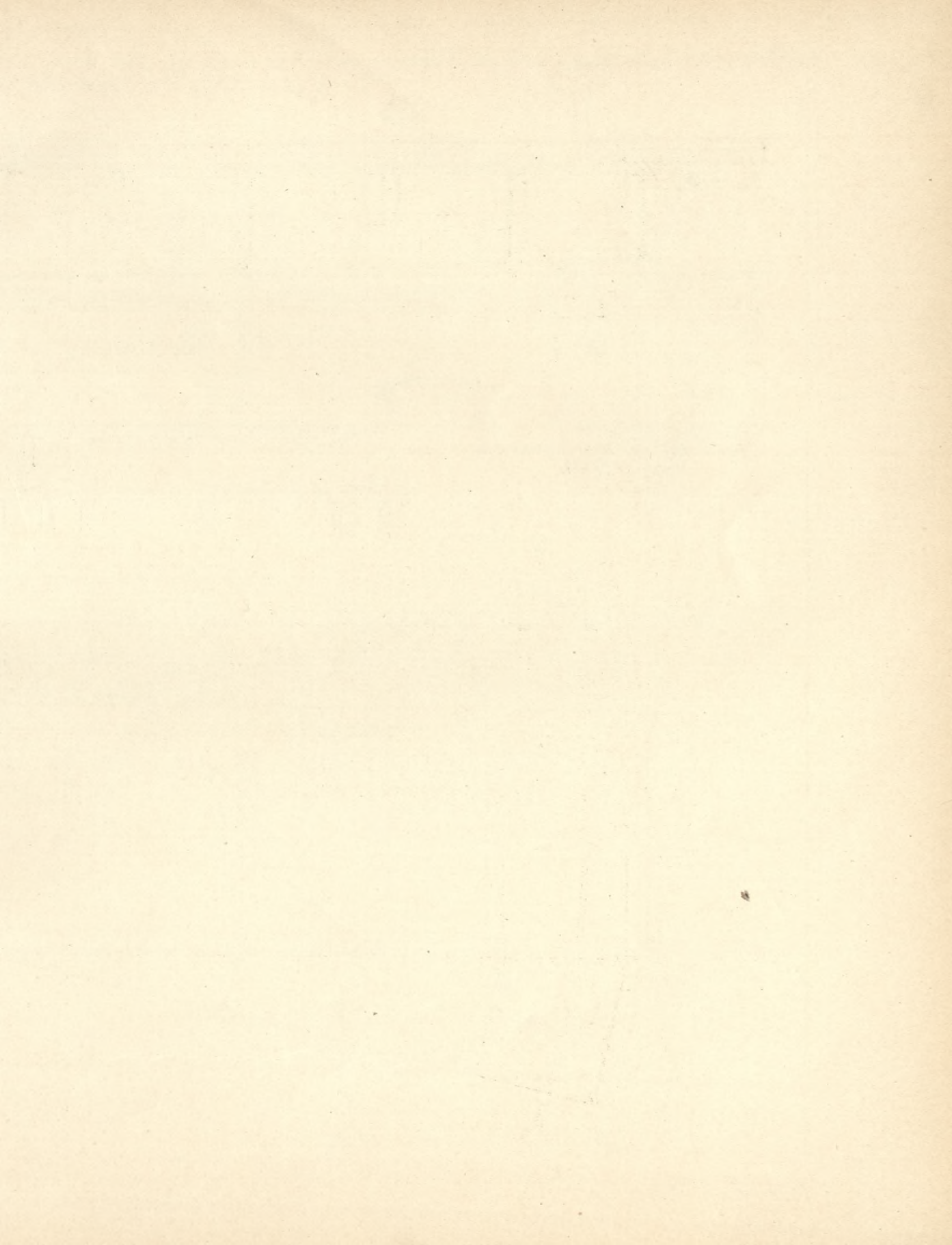
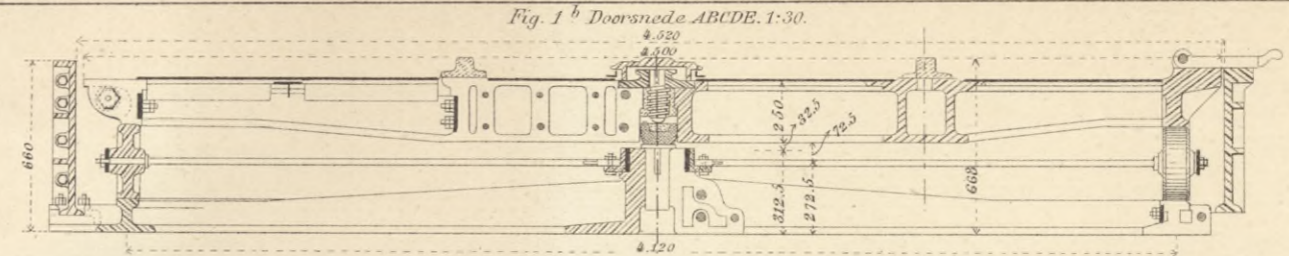
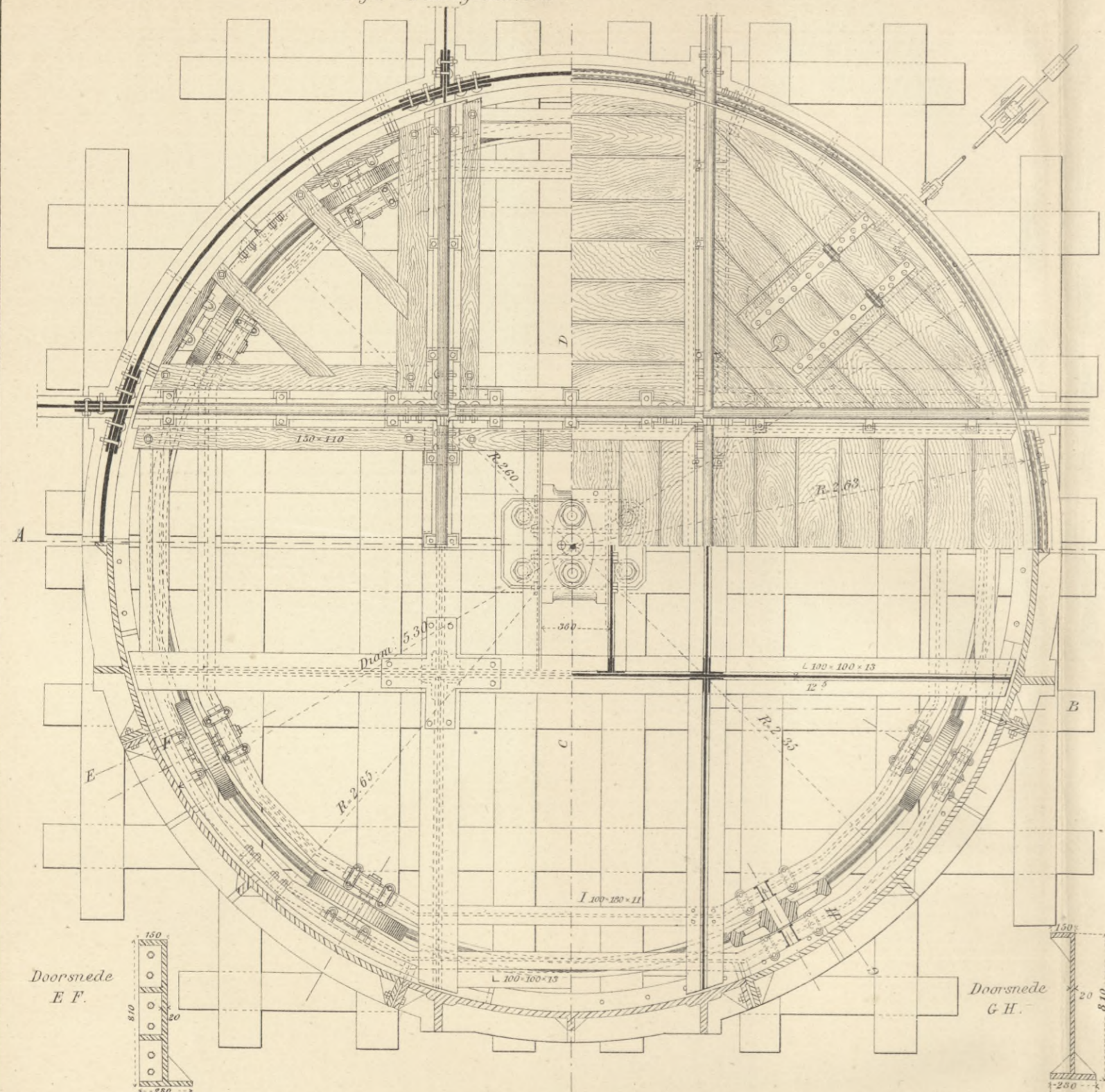
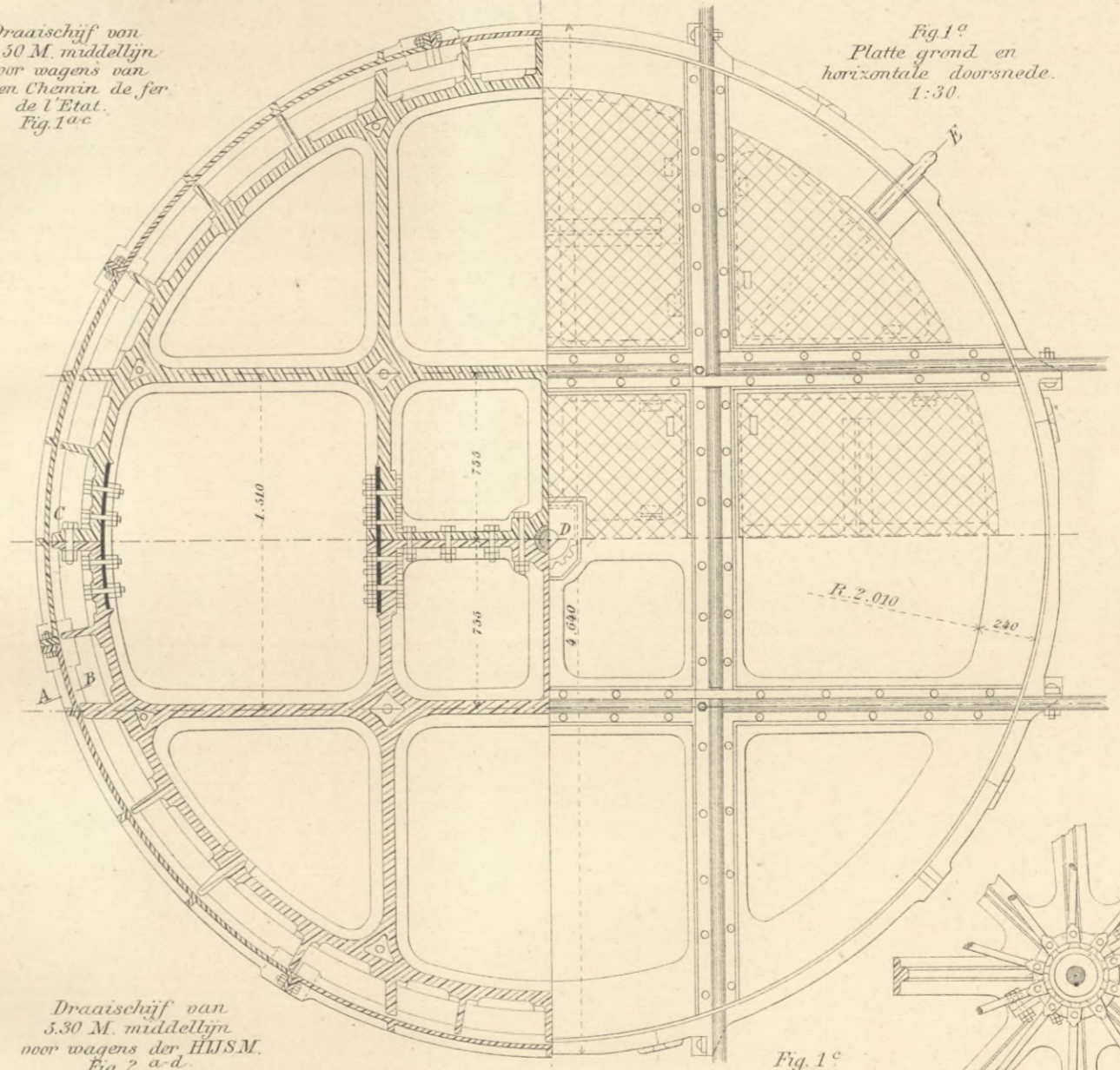


Fig. 2^a Plattegrond. 1:30.



Draaischijf van 4.50 M. middellijn voor wagens van den Chemin de fer de l'Etat. Fig. 1^{a-c}

Fig. 1^a Platte grond en horizontale doorsnede. 1:30.



Draaischijf van 5.30 M. middellijn voor wagens der H.N.S.M. Fig. 2. a-d.

Fig. 1^c Onderbouw met rolring. 1:30.

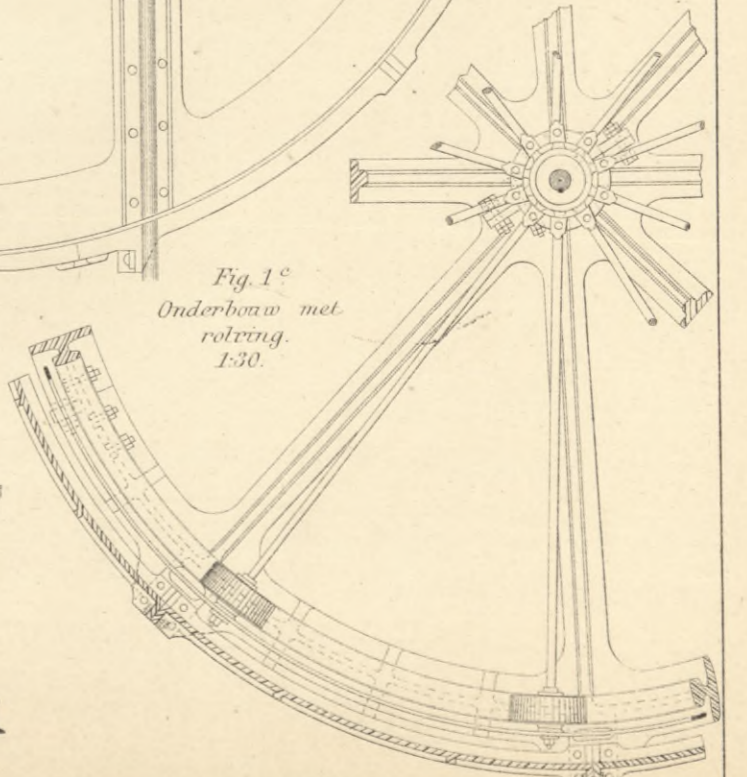


Fig. 2^b Doorsnede AB. 1:30.

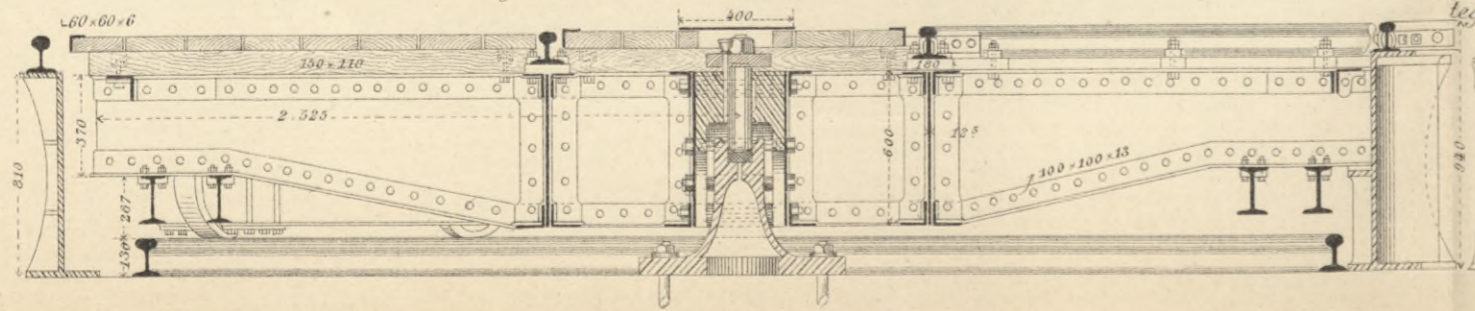


Fig. 1^e Binnen-aanzicht tegen het steunvlak der kuis 1:30.

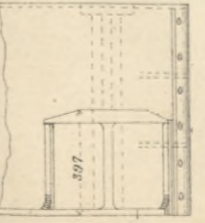
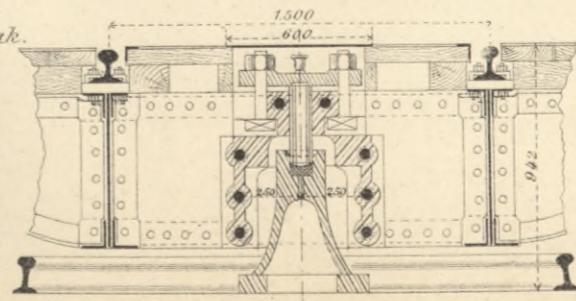


Fig. 2^d Doorsnede CD. 1:30.



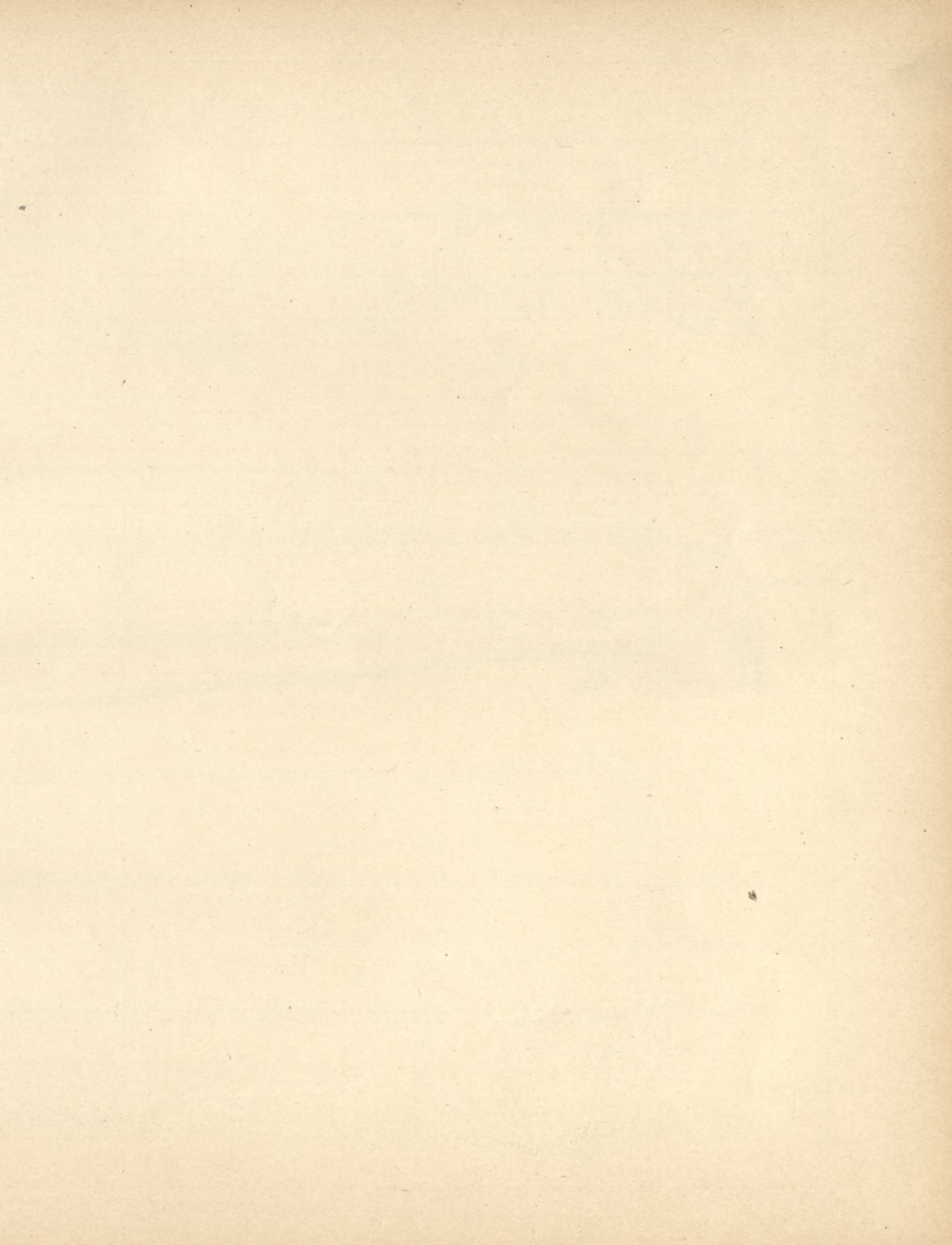


Fig. 1^a Plattegrond en horizontale doorsnede 1:30

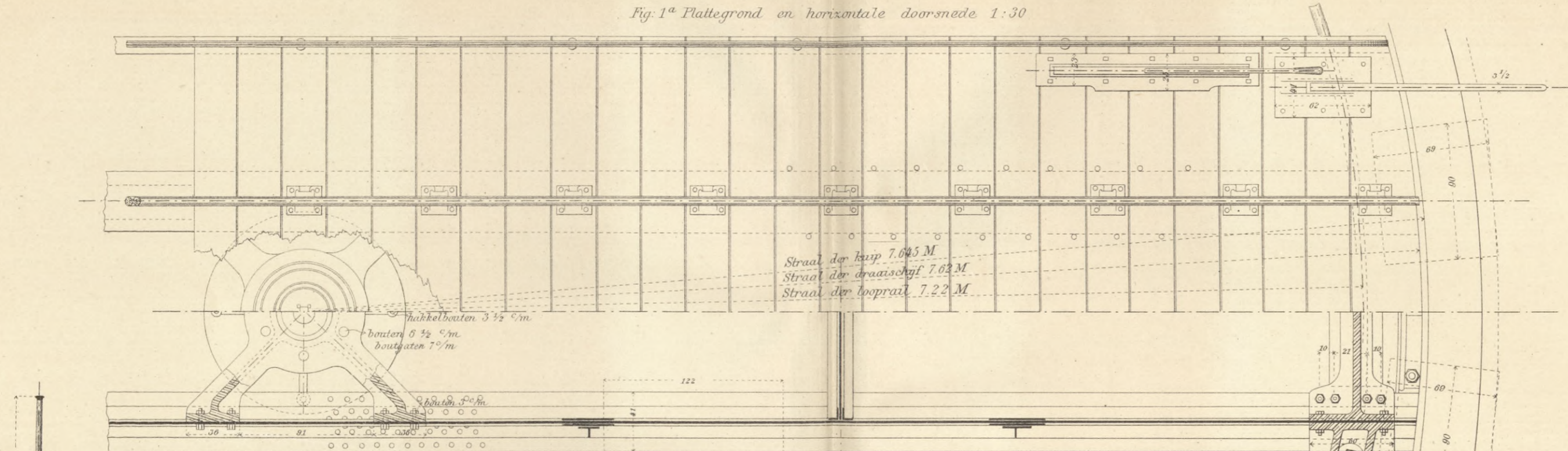
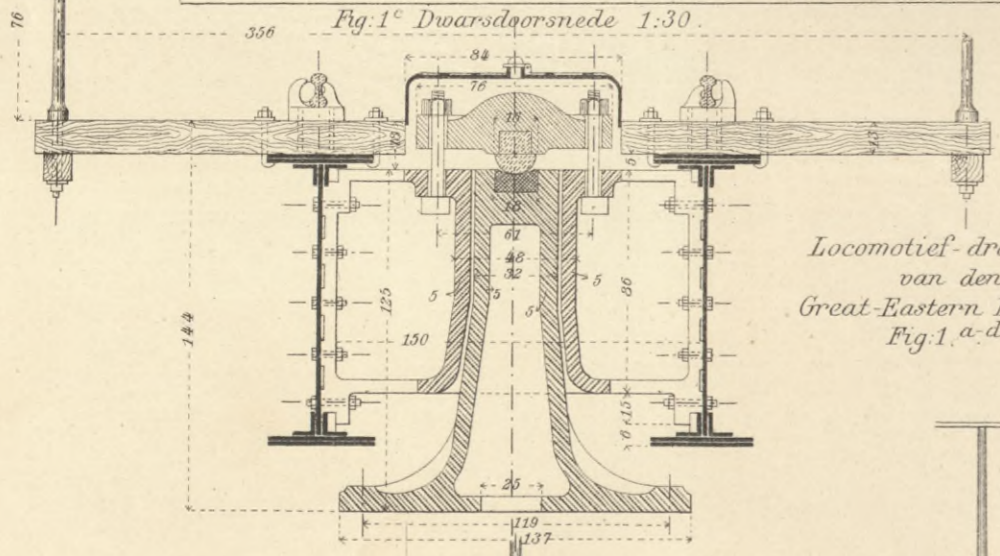


Fig. 1^c Dwarsdoorsnede 1:30



Locomotief-draaischijf van der Great-Eastern Railway. Fig. 1, a-d

Fig. 1^d Vooraanzicht 1:30

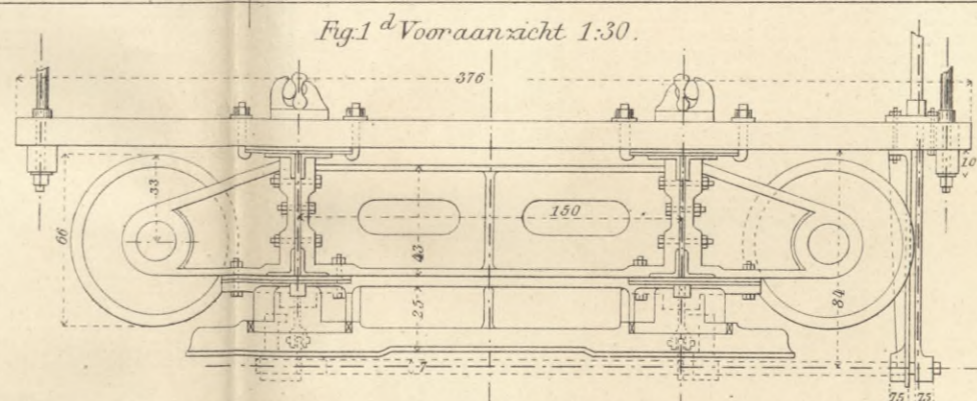


Fig. 1^b Zijaanzicht, gedeeltelijk langsdoorsnede 1:30

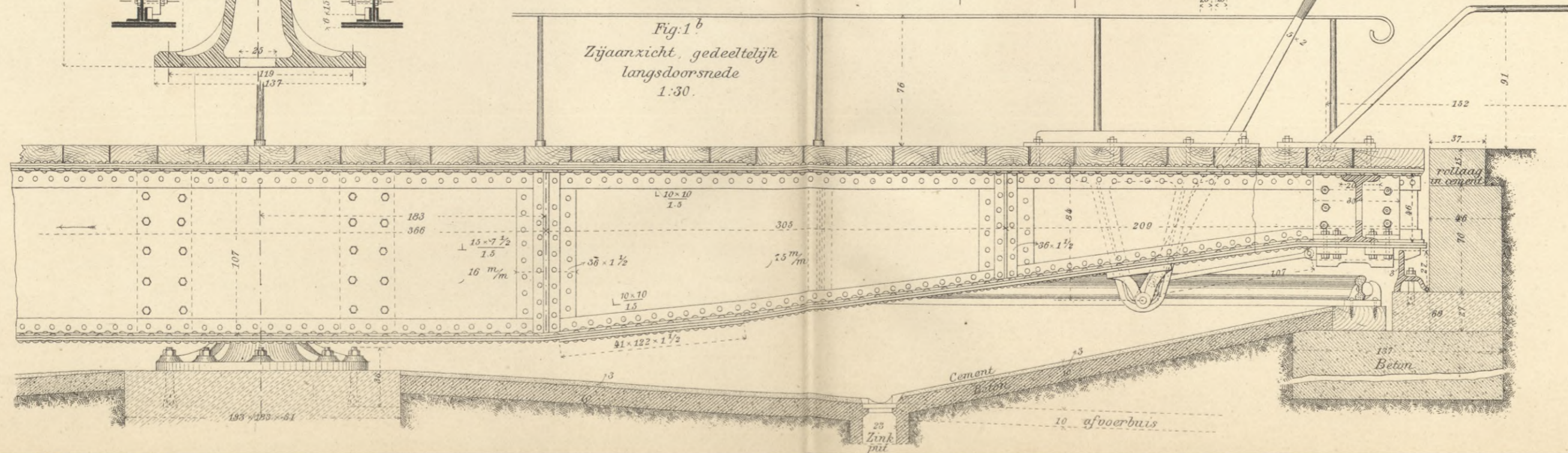
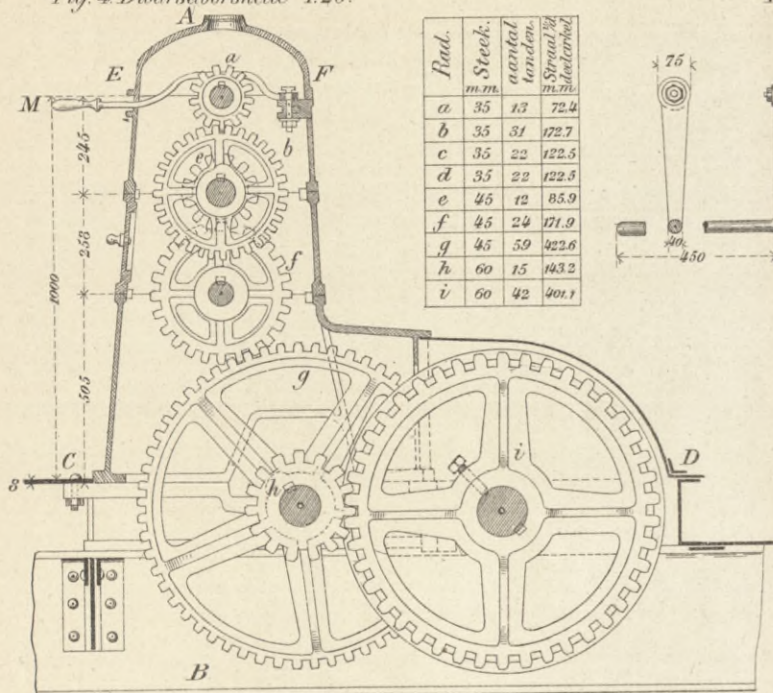
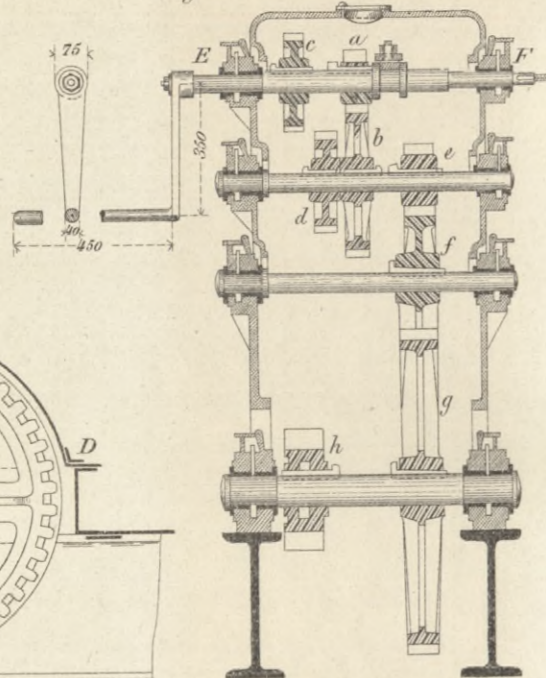


Fig. 4 Dwarsdoorsnede 1:20.



| Rad. | Steek. | aantal tanden. | Spiraal- of draaivertoon. |
|------|--------|----------------|---------------------------|
| m.m. | m.m. | m.m. | m.m. |
| a | 35 | 17 | 72.4 |
| b | 35 | 31 | 172.7 |
| c | 35 | 22 | 122.5 |
| d | 35 | 22 | 122.5 |
| e | 45 | 12 | 85.9 |
| f | 45 | 24 | 171.9 |
| g | 45 | 59 | 322.6 |
| h | 60 | 15 | 143.2 |
| i | 60 | 42 | 401.1 |

Fig. 5 Doorsnede AB 1:20.



Details van het windwerk.

Fig. 7 Doorsnede EF 1:20.

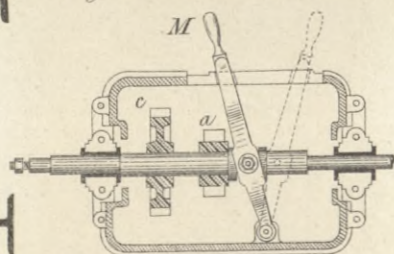


Fig. 6 Doorsnede C.D 1:20.

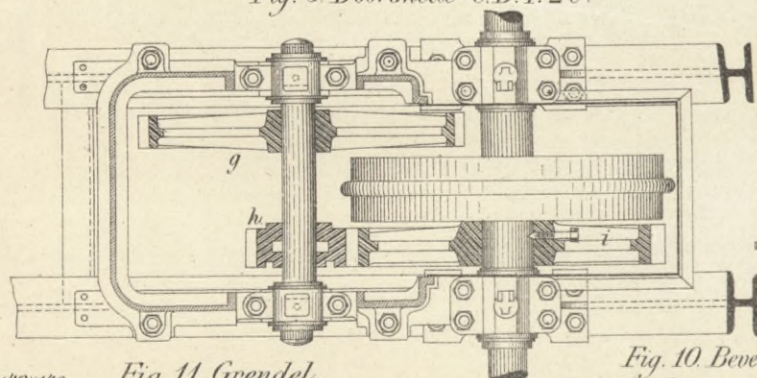


Fig. 10 Bevestiging der draagrails in het midden ter weerszijden 1:10.

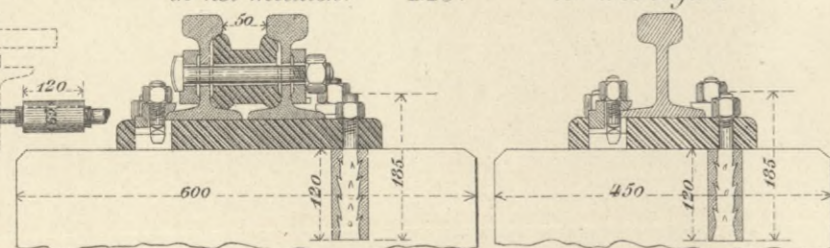


Fig. 3 Dwarsdoorsnede 1:40.

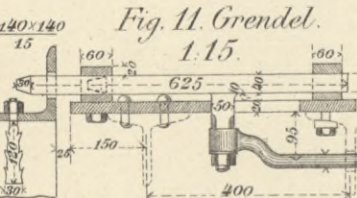


Fig. 11 Grendel 1:15.

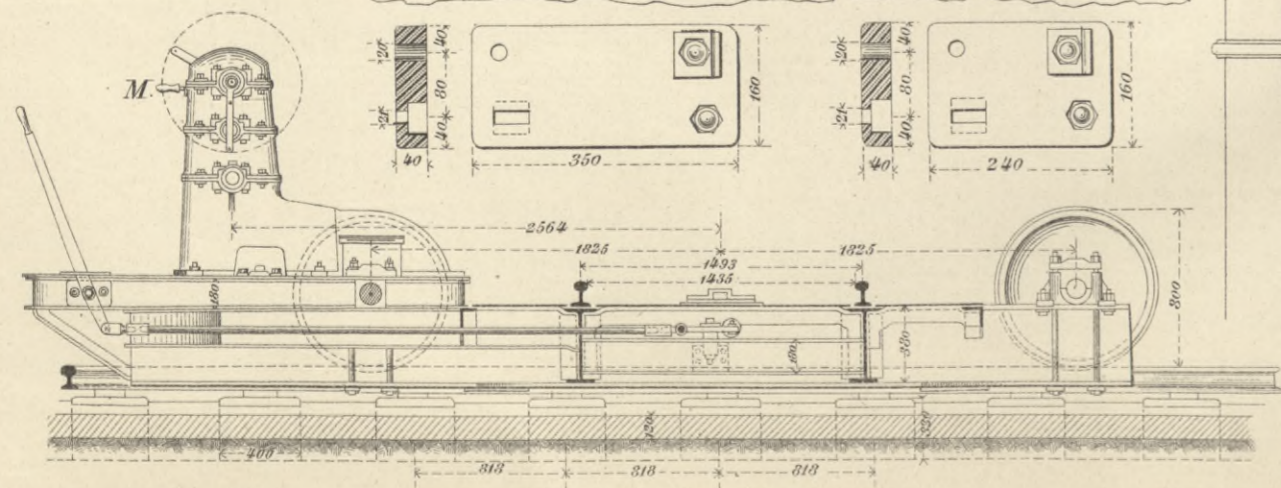
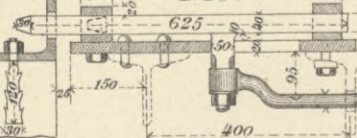
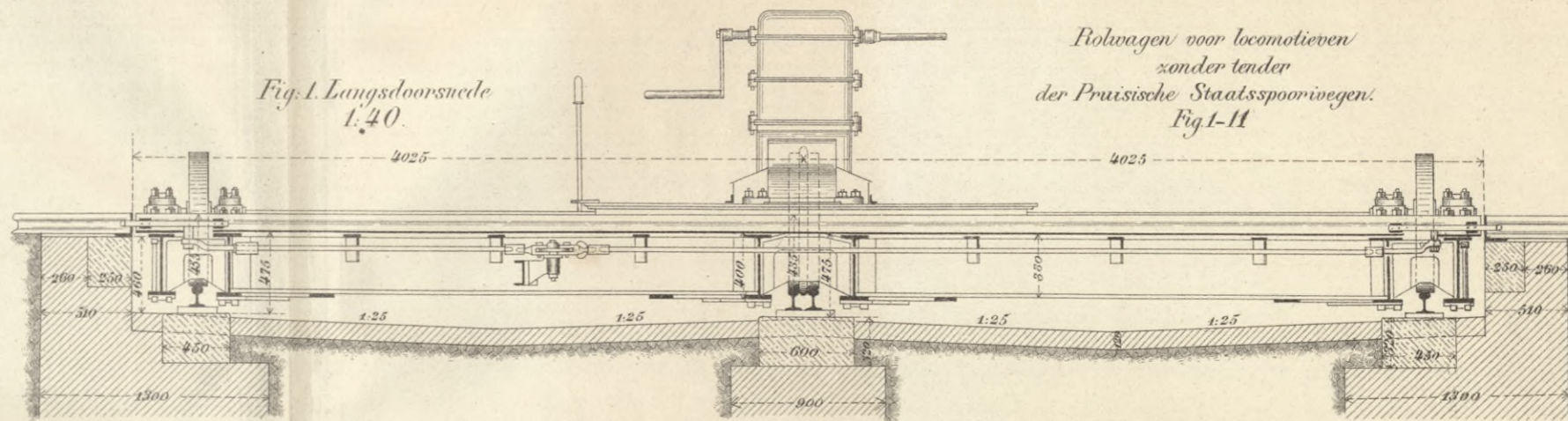
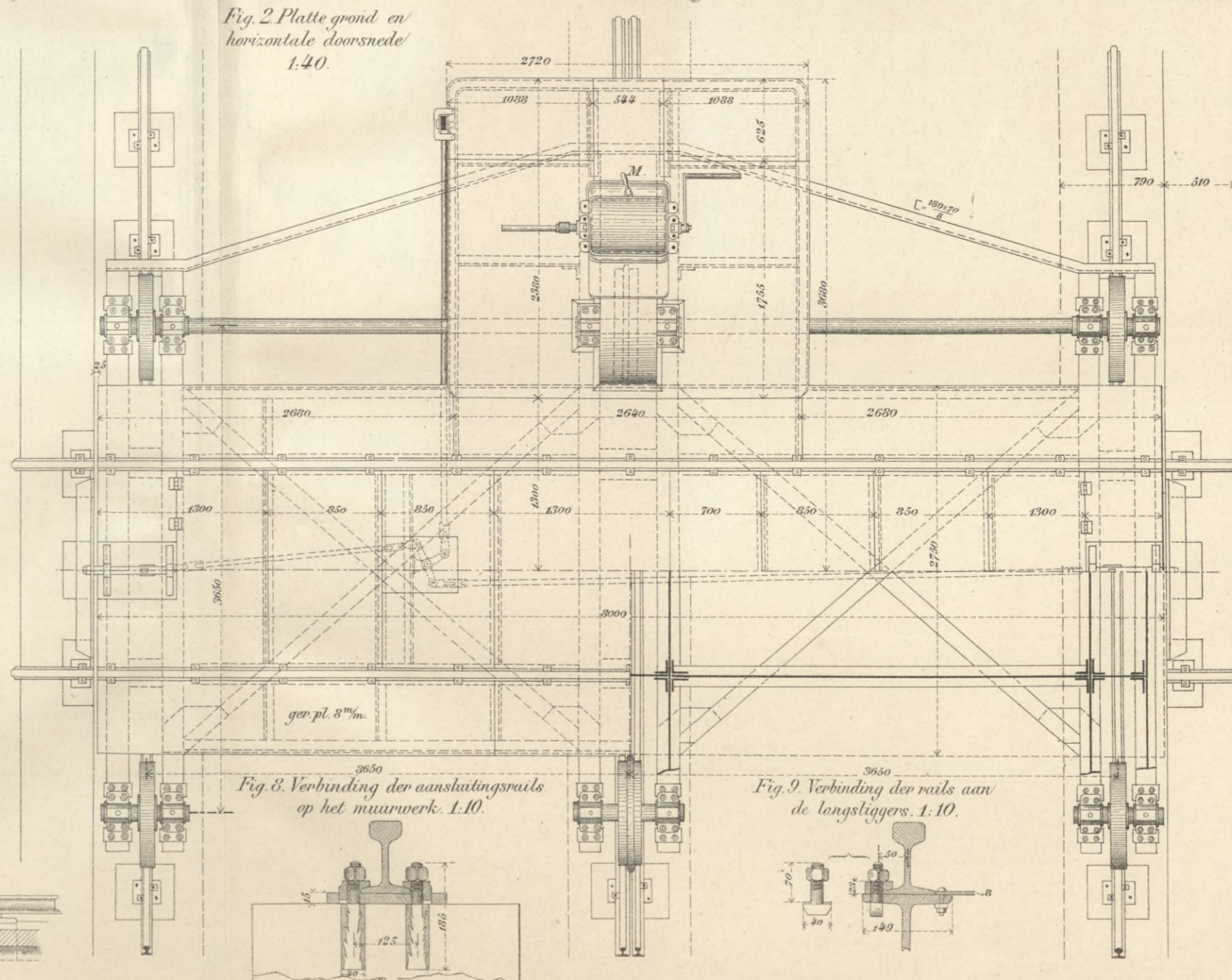


Fig. 1 Langdoorsnede 1:40.



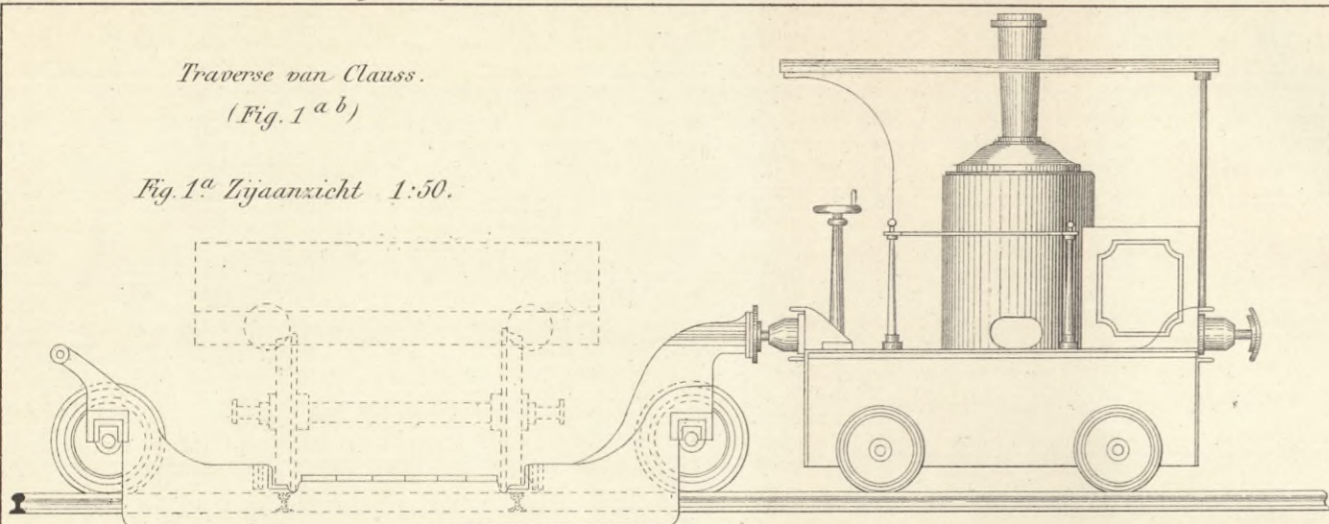
Rollwagen voor locomotieven zonder tender der Pruisische Staatsspoorwegen. Fig. 1-11

Fig. 2 Platte grond en horizontale doorsnede 1:40.



Traverse van Clauss.
(Fig. 1^a b)

Fig. 1^a Zijaanzicht 1:50.



Traverse van Ehrhardt & Schmer.
(Fig. 2^{a-c})

Fig. 2^a Aanzicht 1:40.

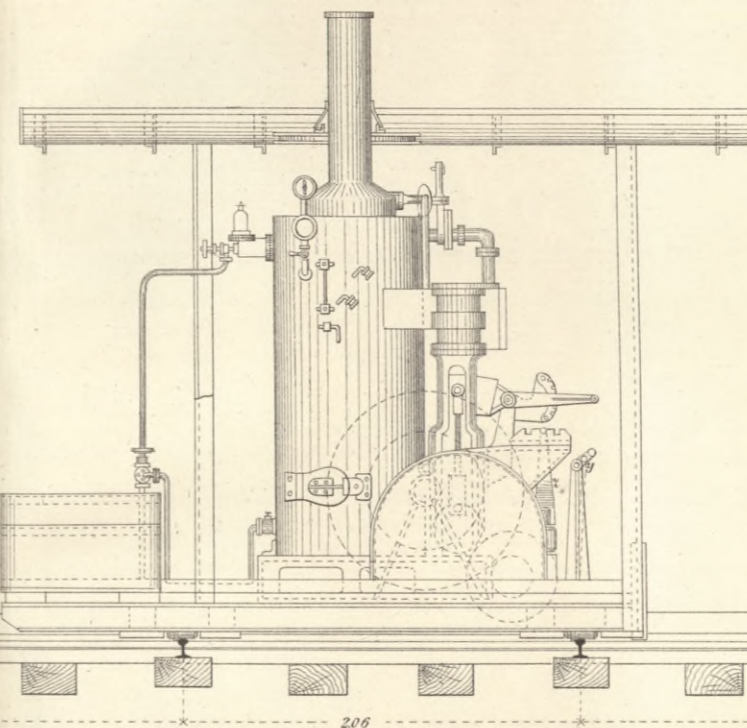


Fig. 3^a Doorsnede c.d.e.f. 1:50.

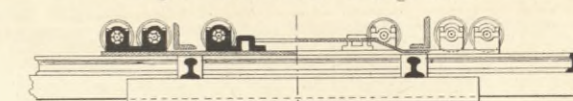


Fig. 3^b Plattegrond 1:50

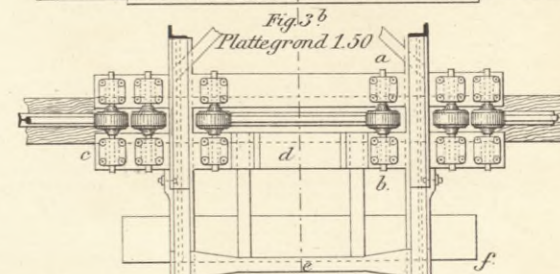
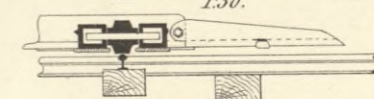
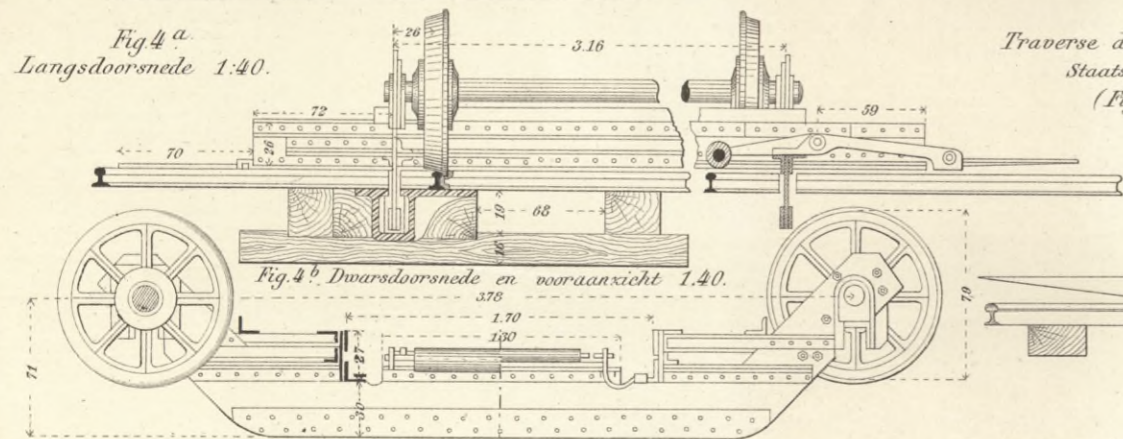


Fig. 3^c Doorsnede a.b. 1:50.



Traverse van Klett.
(Fig. 3^{a-c})

Fig. 4^a Langdoorsnede 1:40.



Traverse der Oostenrijksche
Staatspoorwegen.
(Fig. 4^a b)

Fig. 4^b Dwarsdoorsnede en vooraanzicht 1:40.

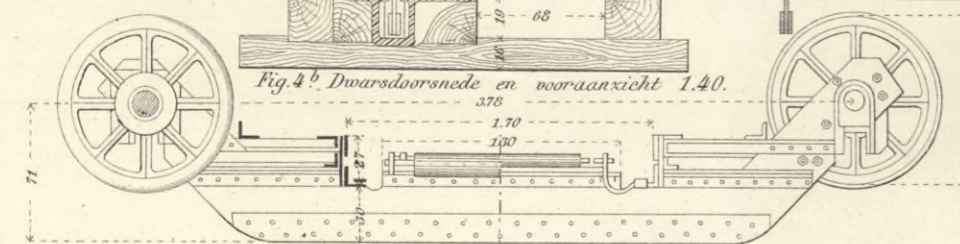


Fig. 2^b Plattegrond 1:40.

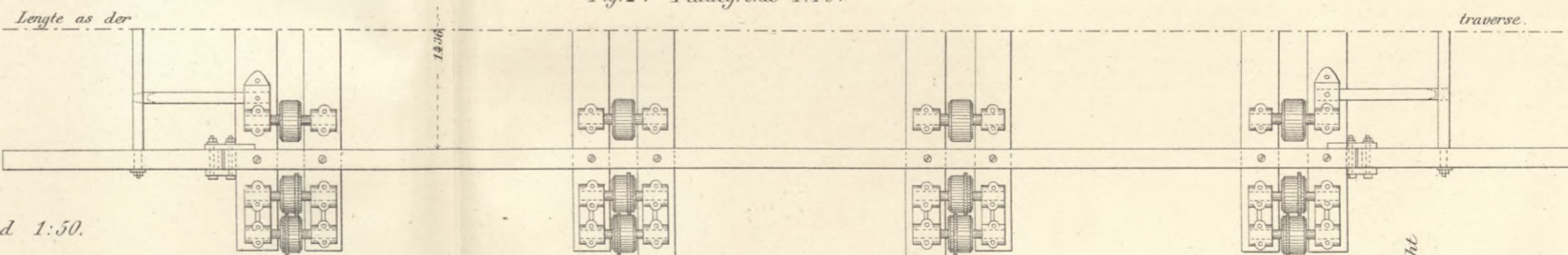


Fig. 1^b Plattegrond 1:50.

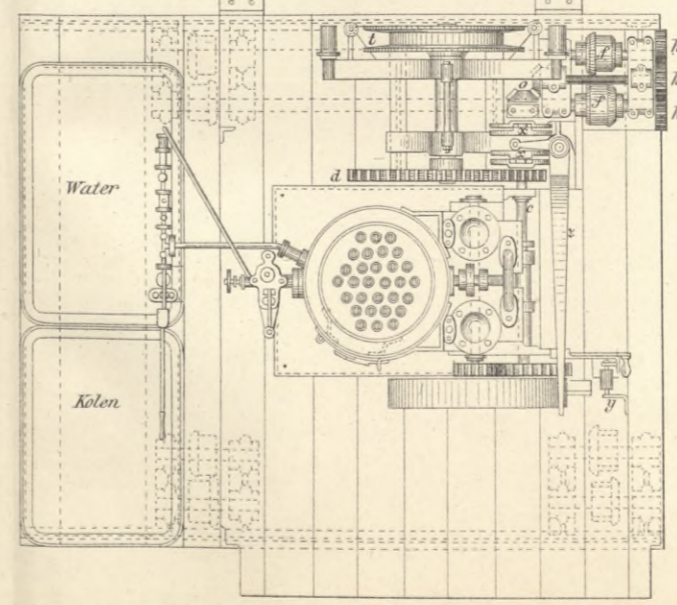
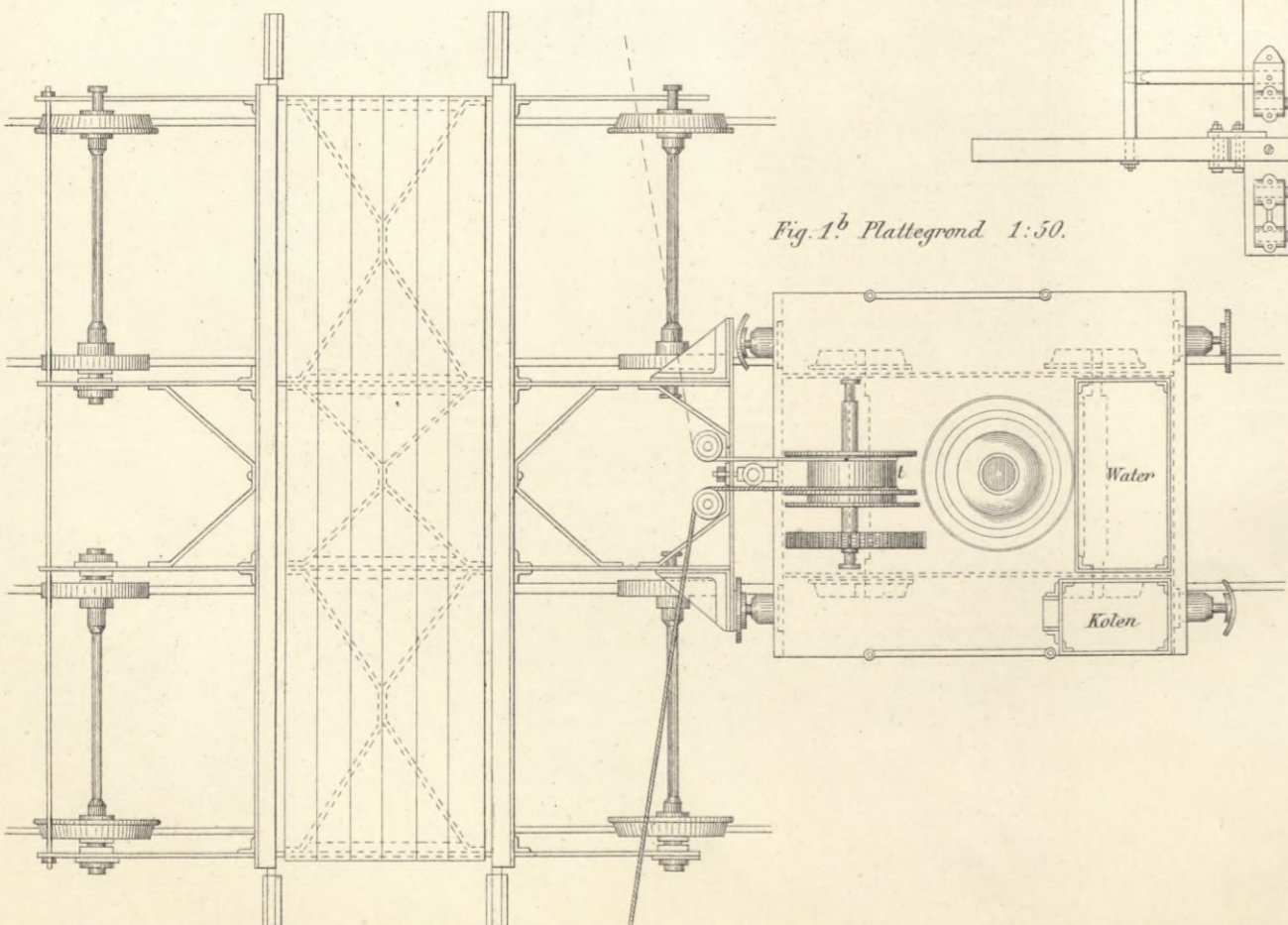


Fig. 2^c Zijaanzicht 1:40.

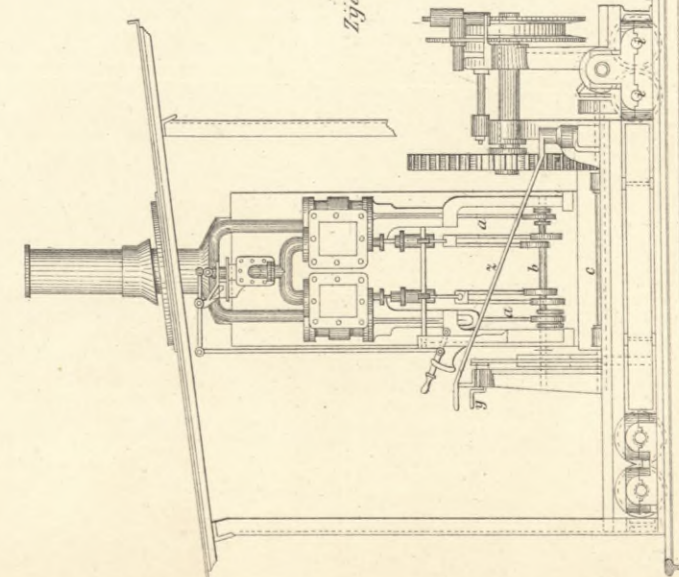
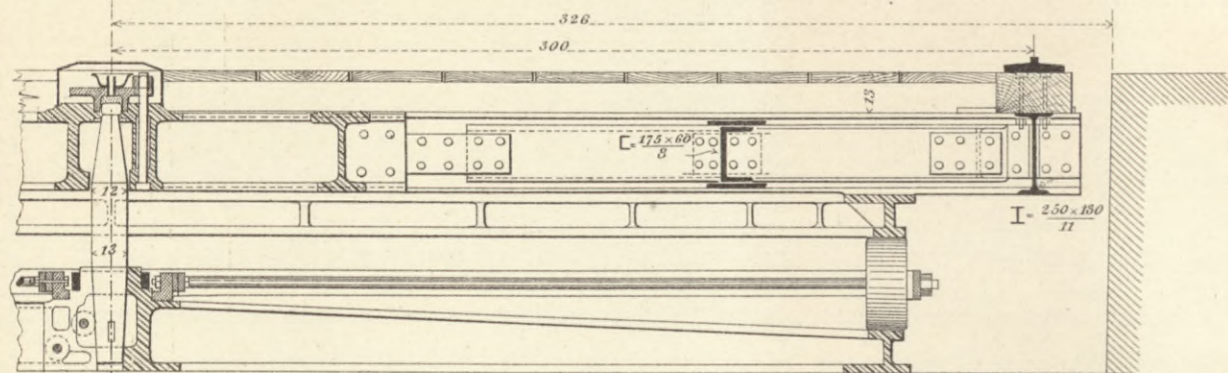
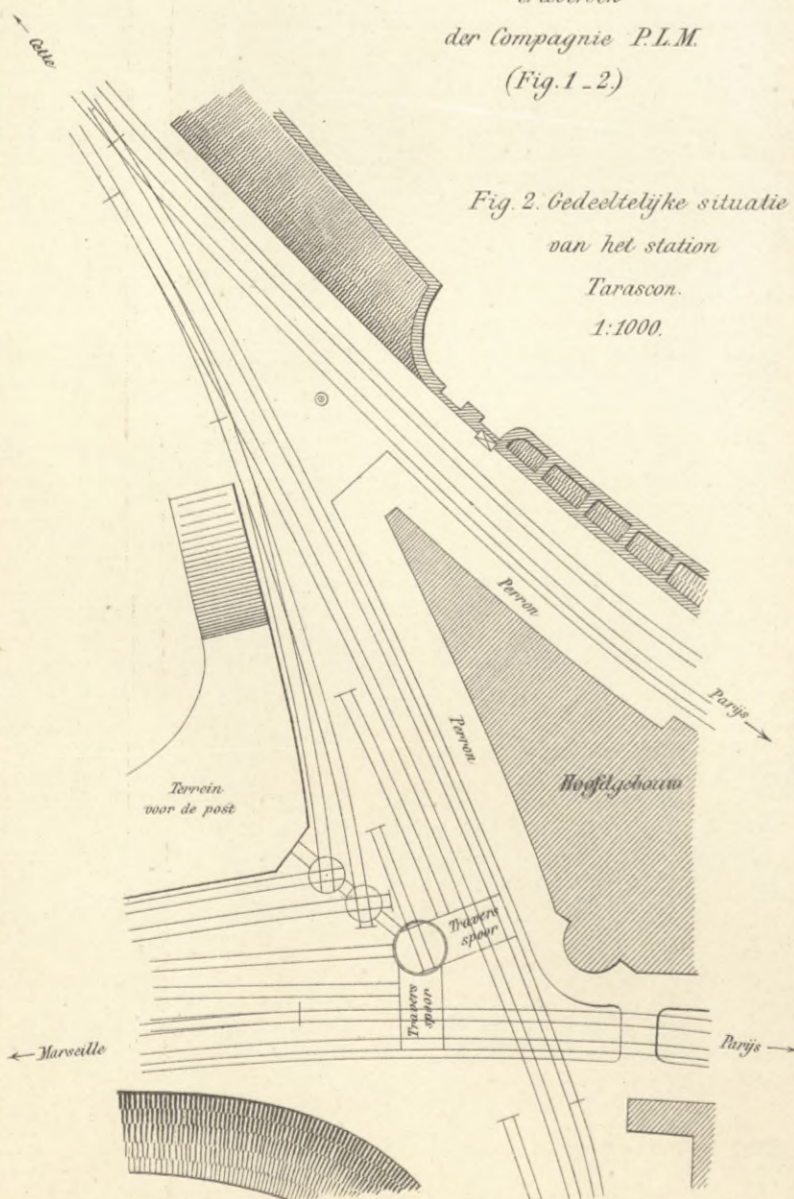


Fig. 1. Horizontale doorsnede der draaischijf 1:25.



Draaischijf voor
traverseen
der Compagnie P.L.M.
(Fig. 1-2)

Fig. 2. Gedeeltelijke situatie
van het station
Tarascon.
1:1000.



Rolwagen met draaischijf der Compagnie de l'Ouest, op het station St. Lazare te Parijs (Fig. 3-5)

Fig. 3. Doorsnede AB. 1:80.

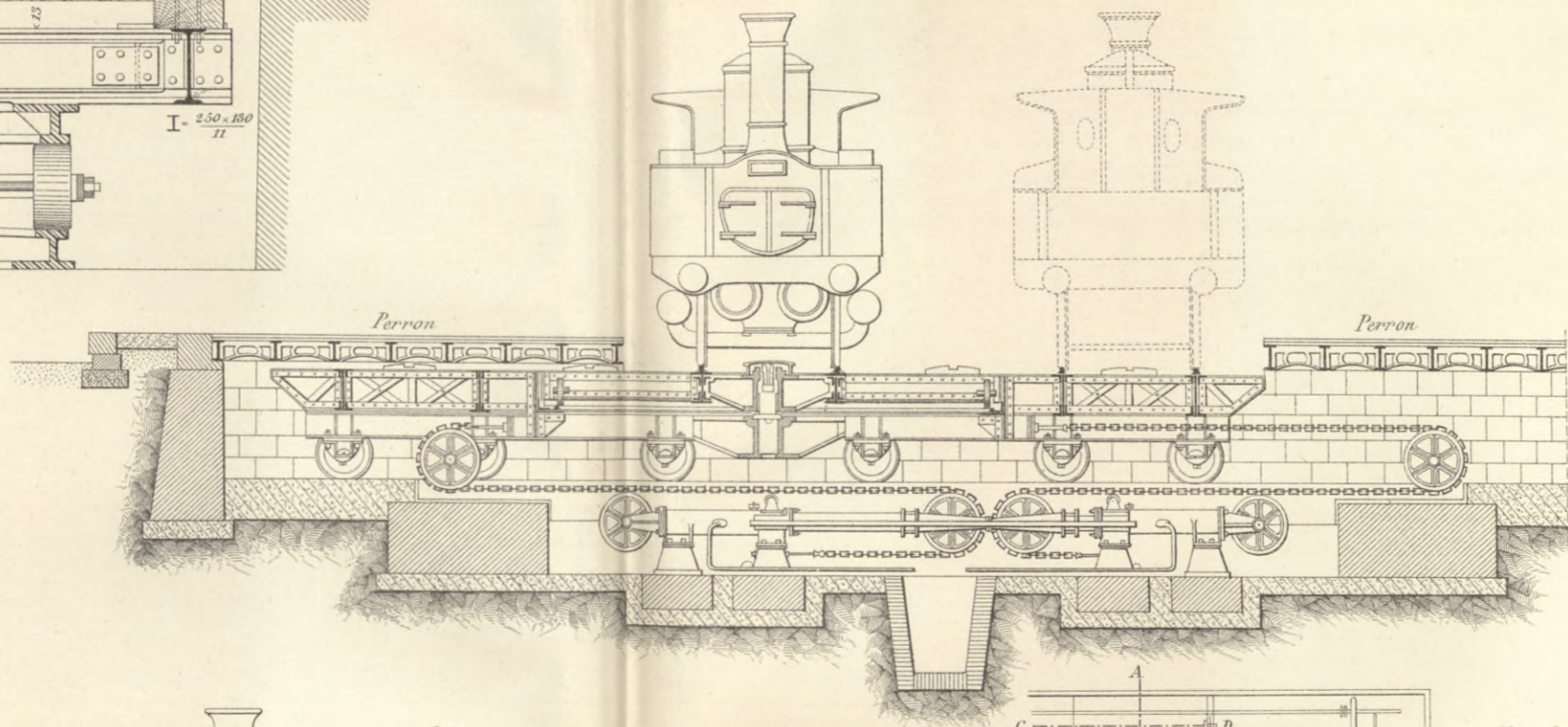


Fig. 4. Doorsnede C.D.E.F. 1:80.

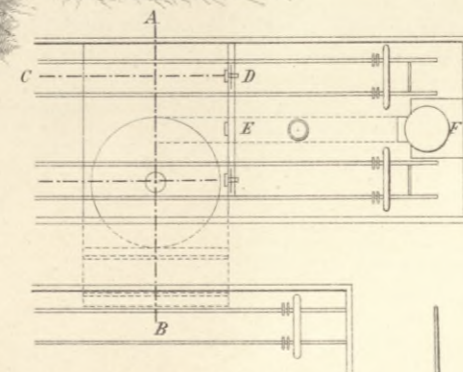
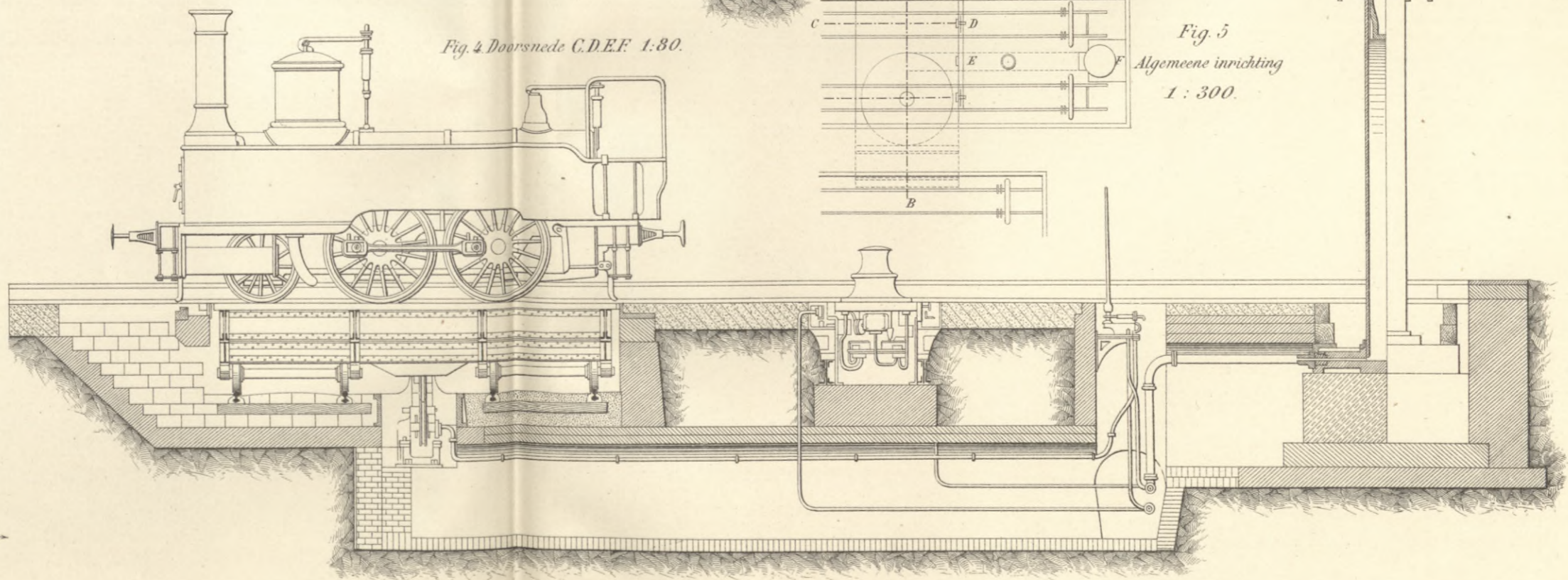
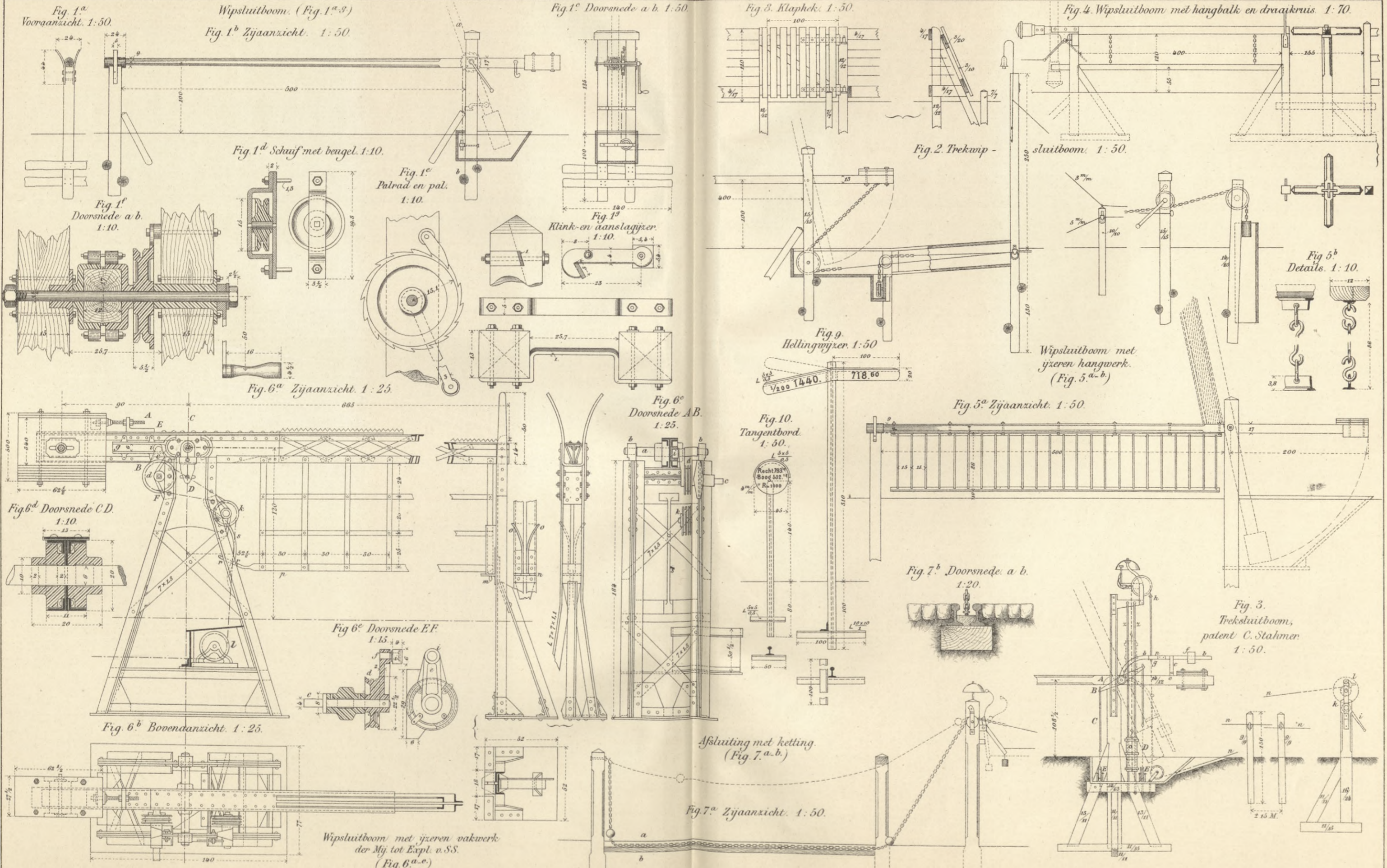
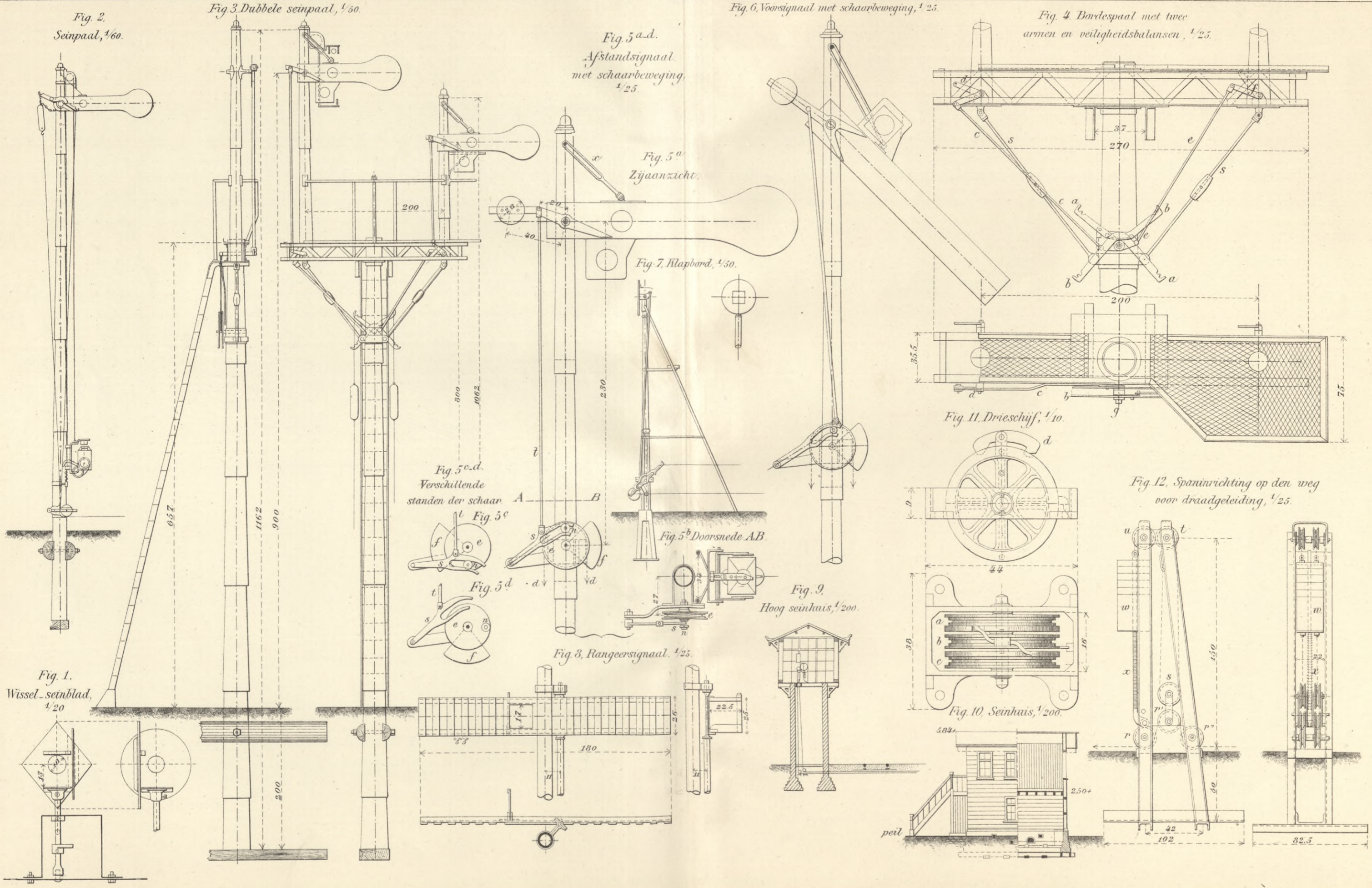


Fig. 5
Algemeene inrichting
1:300.





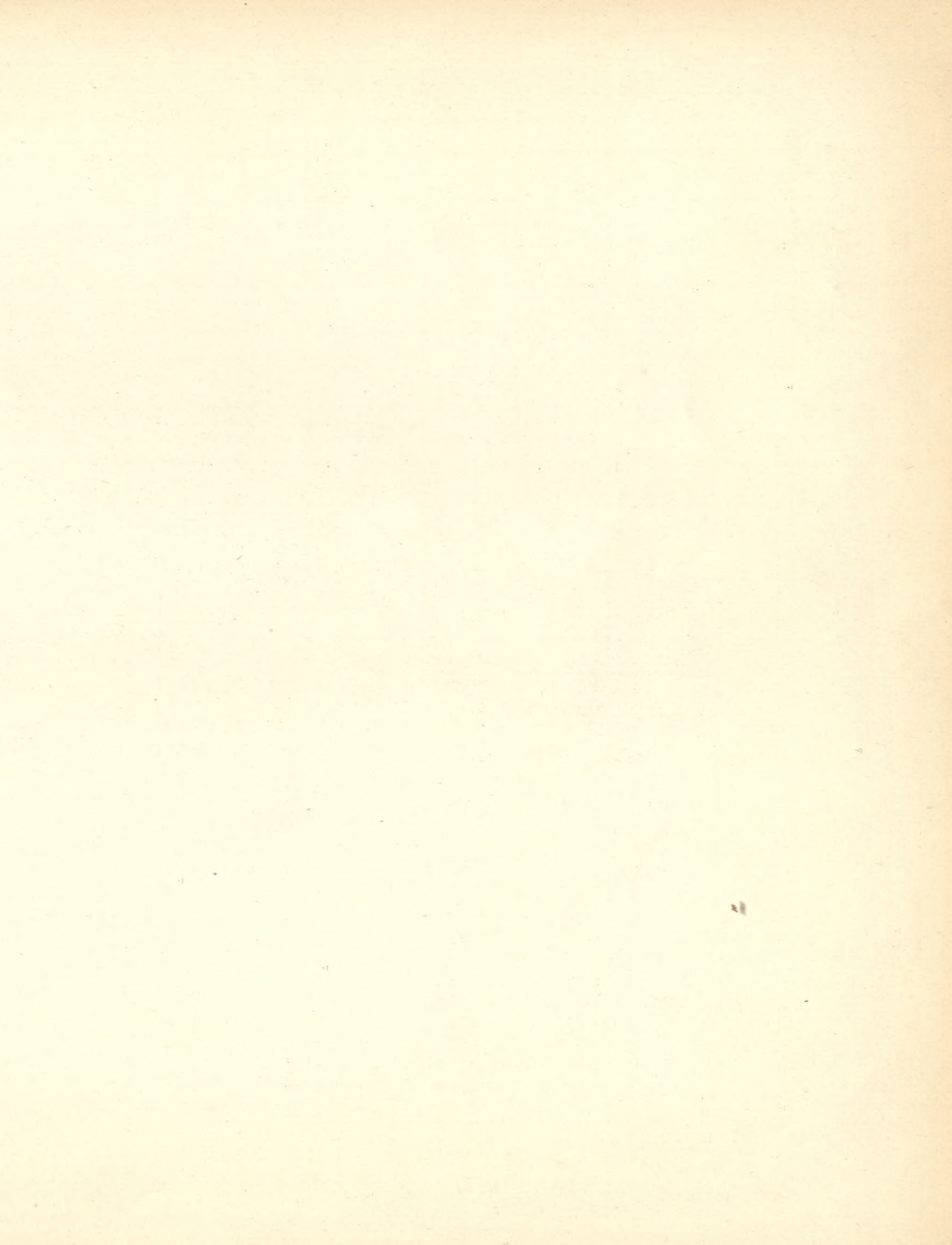


Fig. 1. Electrisch klokwerk van Hramer 1/3.

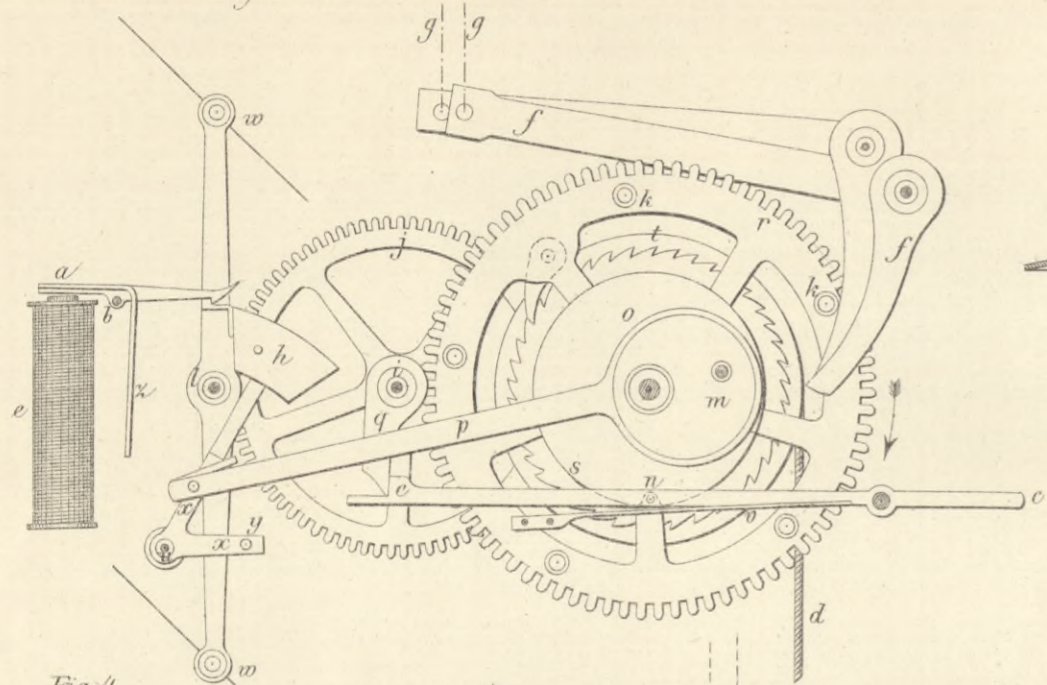
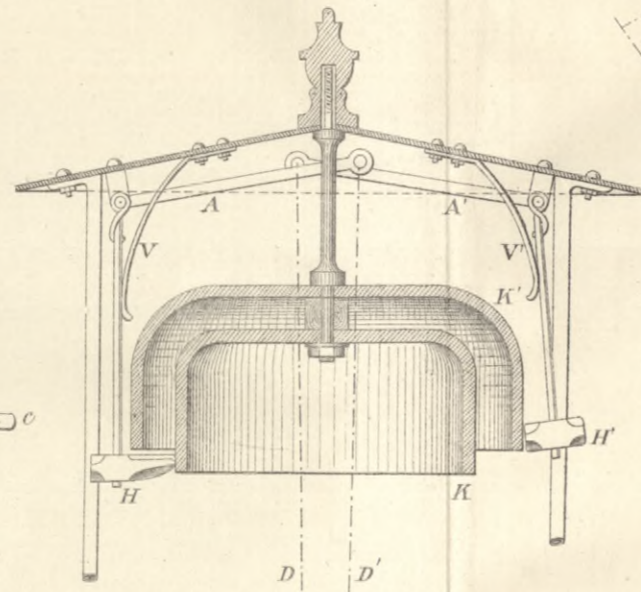


Fig. 2. Doorsnede over het dak van een klokkenhuis 1/3.



Centraal bewegingstoestel systeem Saxby & Farmer. Fig. 5 a-e

Fig. 5 a
Dwarsdoorsnede der geheele
wrichting 1/10.

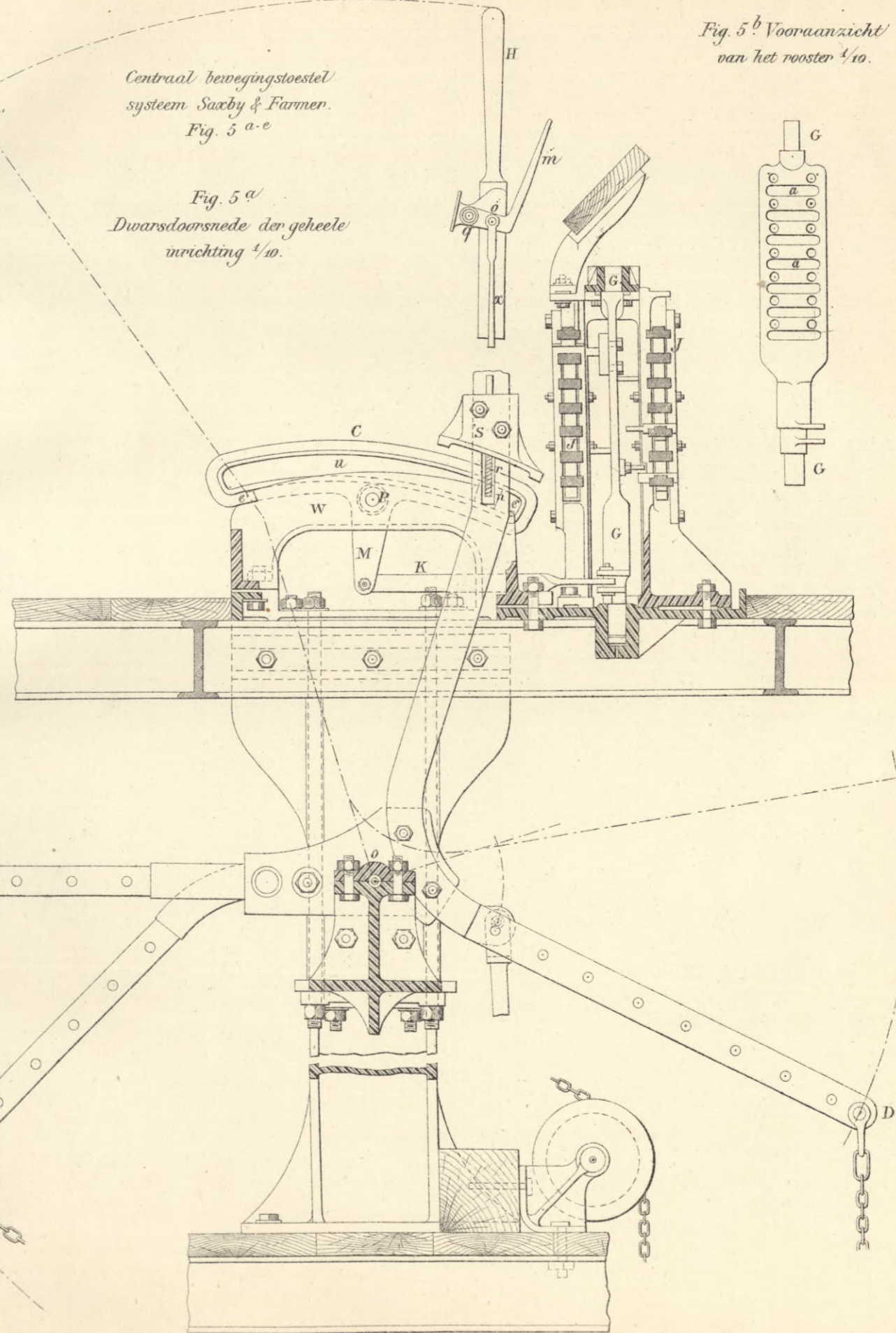


Fig. 5 b
Vooraanzicht
van het rooster 1/10.

Fig. 4
Klokken-xuif
1/25.

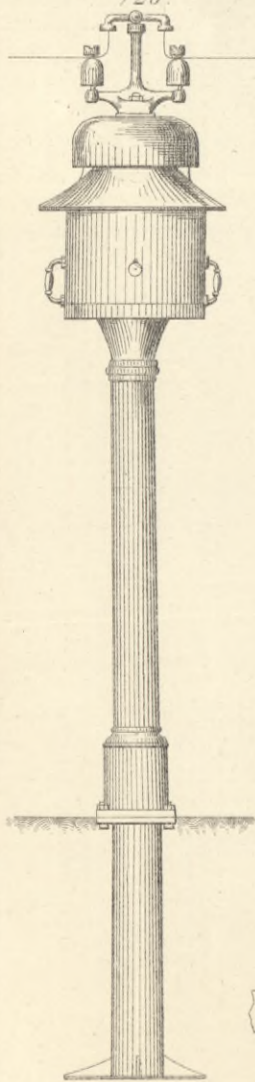


Fig. 3. Electrisch klokwerk
van Siemens en Halske
1/3.

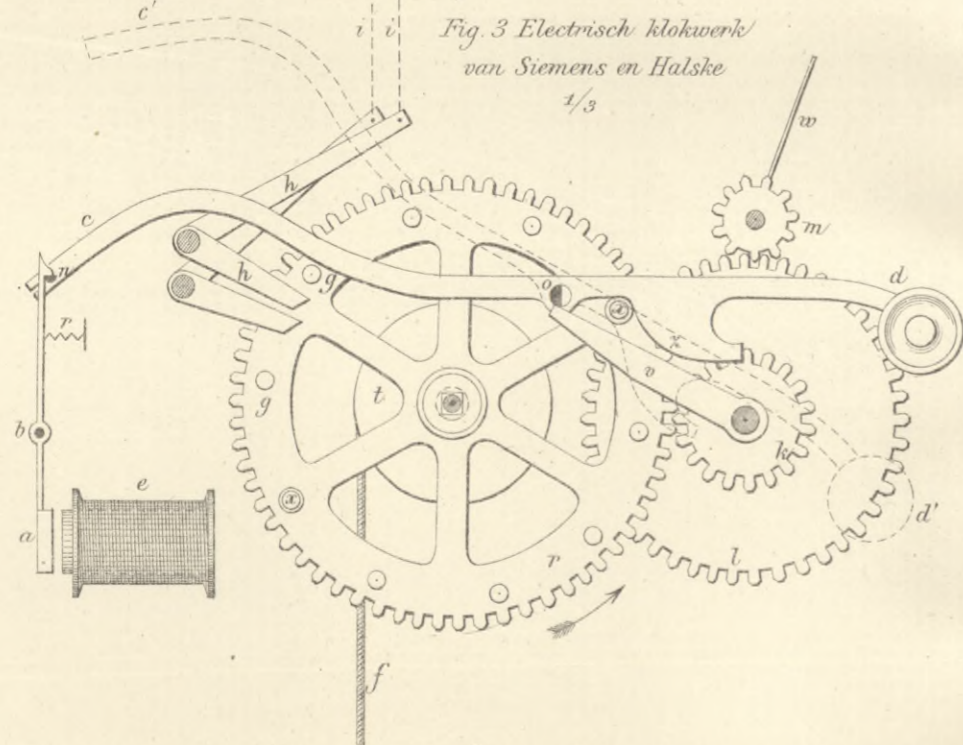


Fig. 5 c
Verschillende voorbeelden van koppelingen met vorken en nokken 1/4.

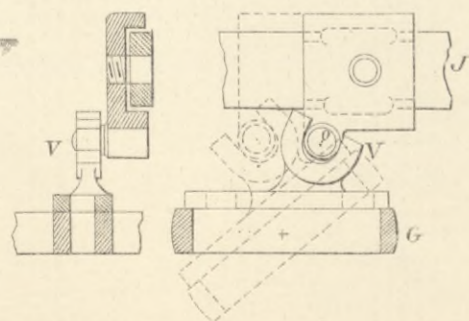


Fig. 5 d

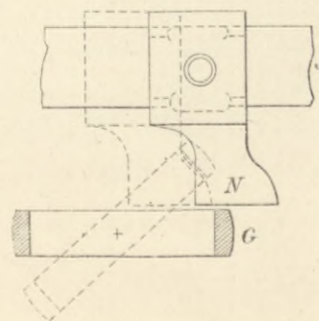


Fig. 5 e

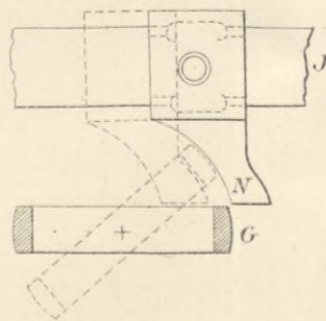


Fig 2^a
Blokast en trekkerkast met
weggenomen voorwanden 1/5.

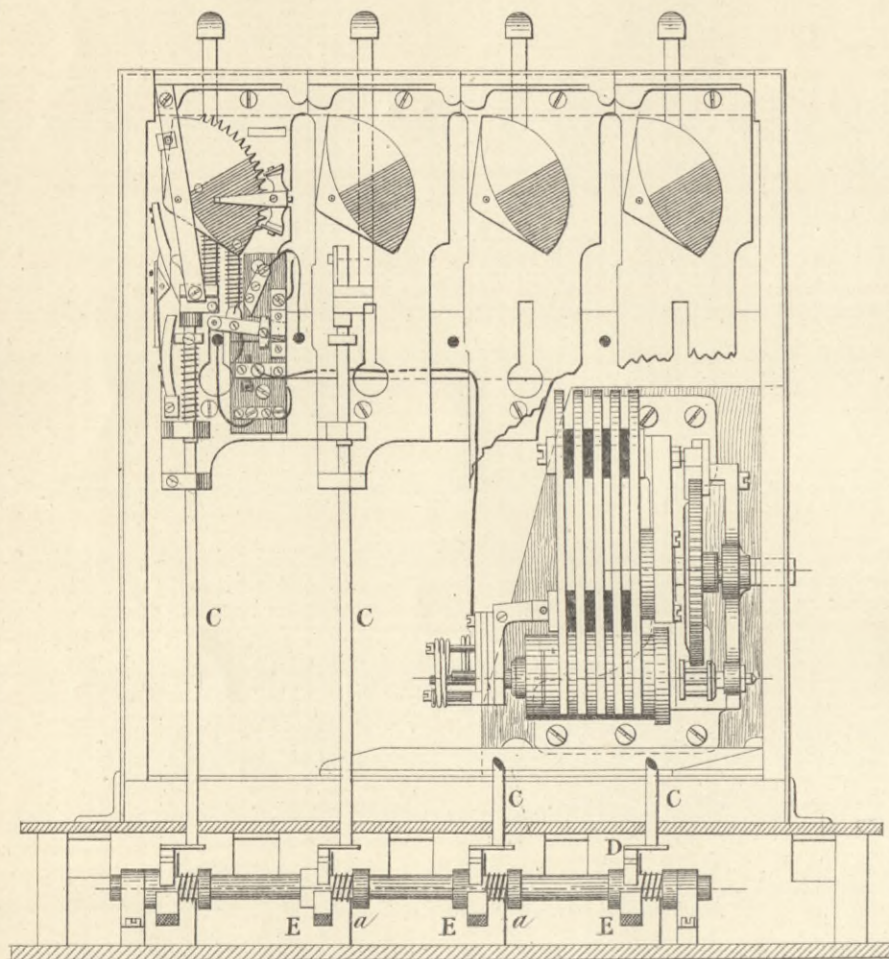
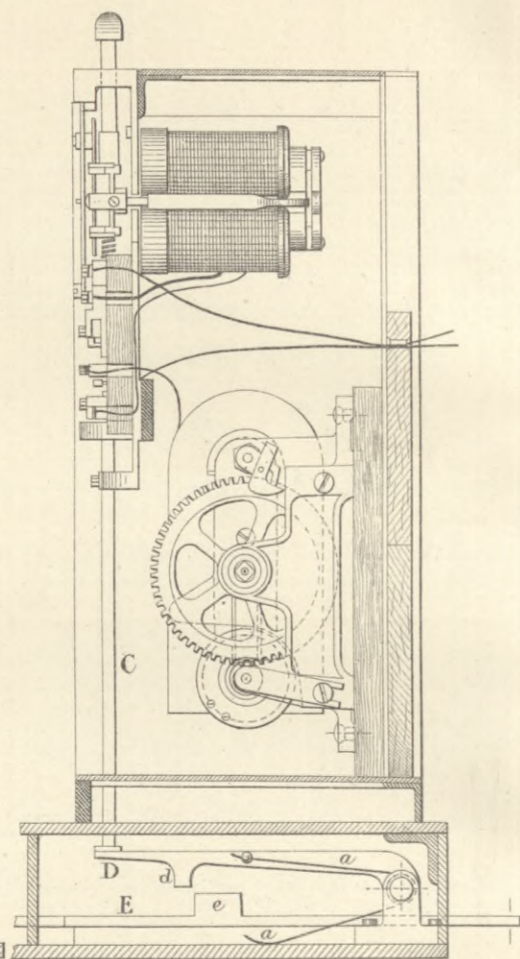


Fig 2^b
Blokast en trekkerkast met
weggenomen zijwanden 1/5.



Centraal bewegingstoestel
met blok,
constructie der H.H.S.M.
(fig 1^{a-b} en 2^{a-d})

Fig 1^a
Vooranzicht der
geheele inrichting 1/10.

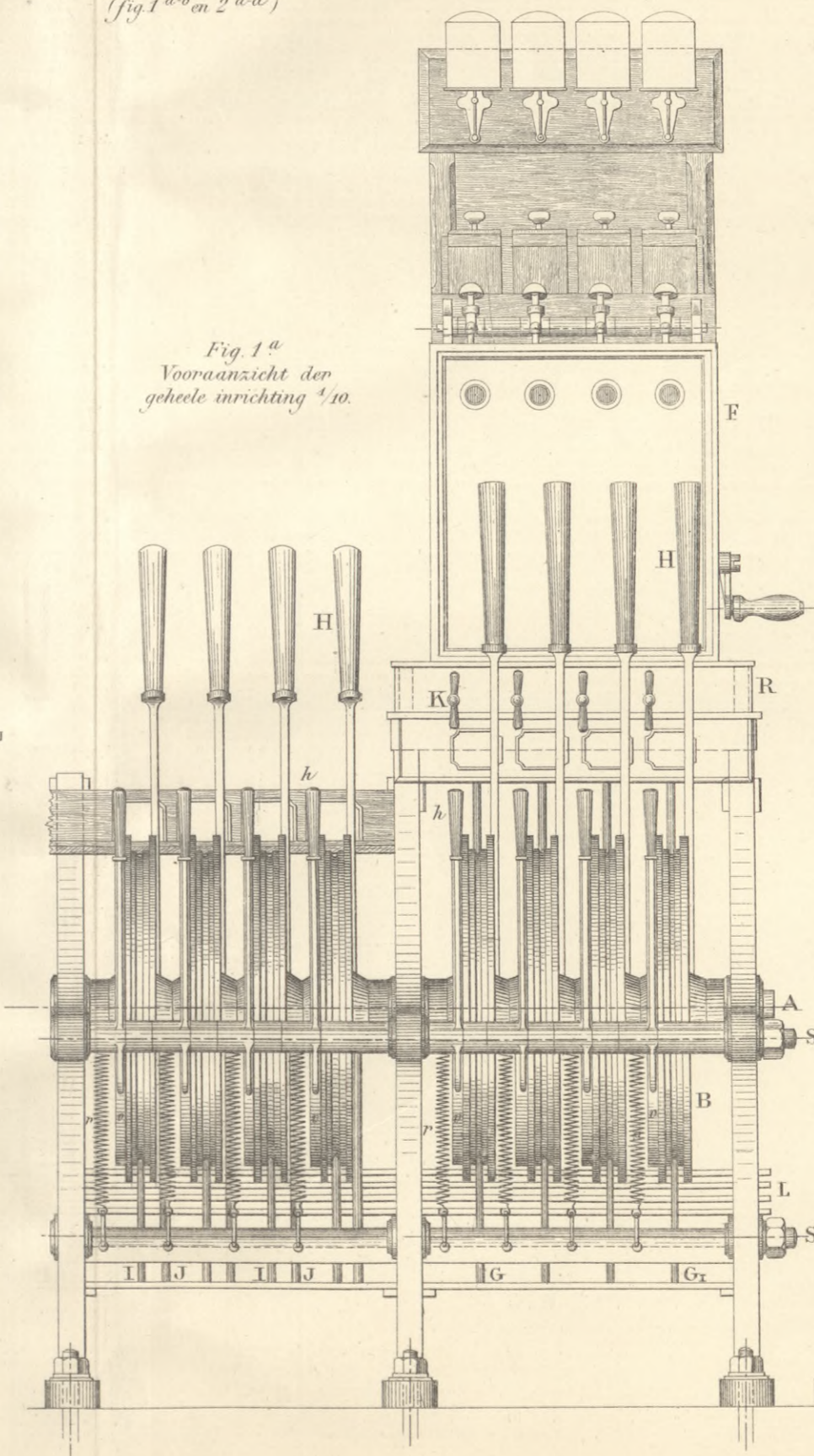


Fig 1^b
Zijaanzicht der
geheele inrichting 1/10.

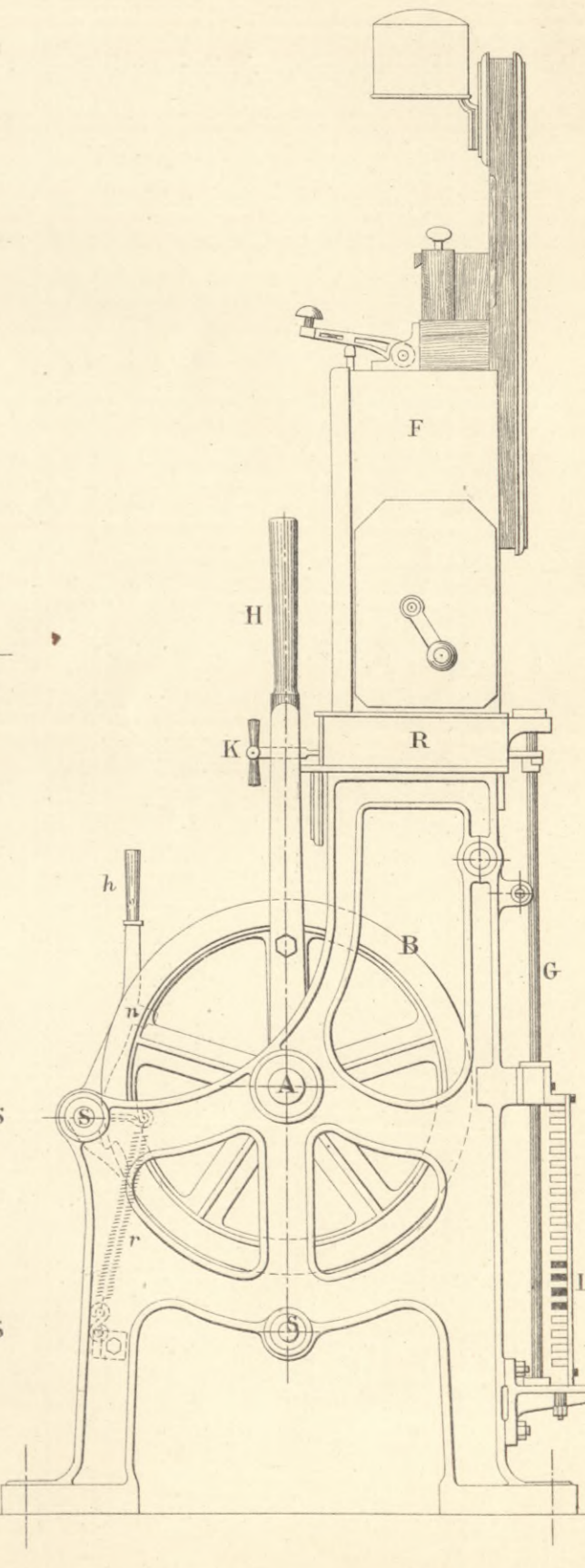


Fig 2^c
Horizontale doorsnede over de trekkerkast 1/5.

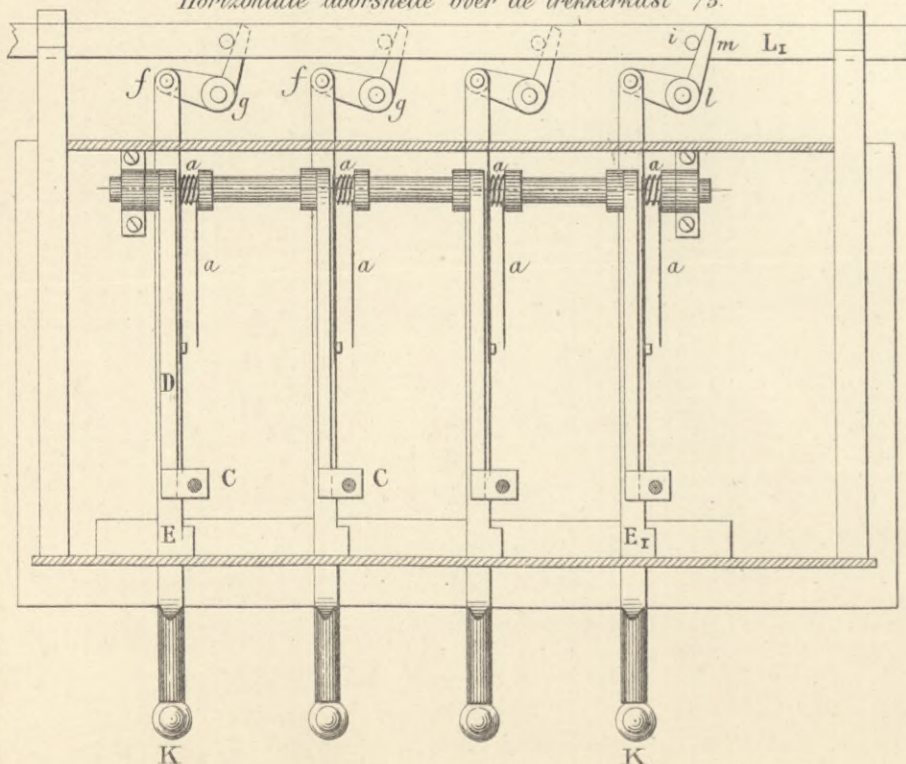


Fig 2^d
Horizontale doorsnede
over de blokast 1/5.

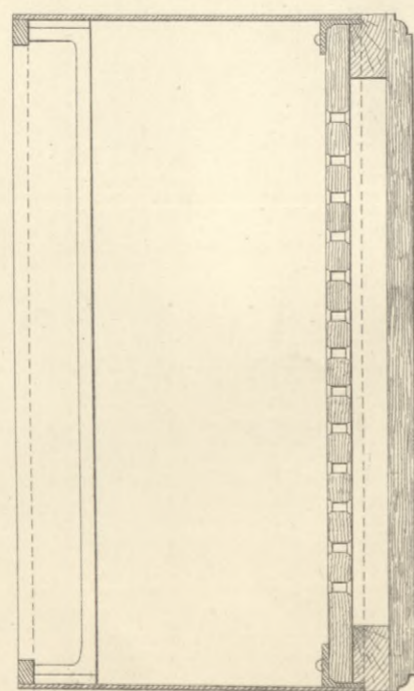
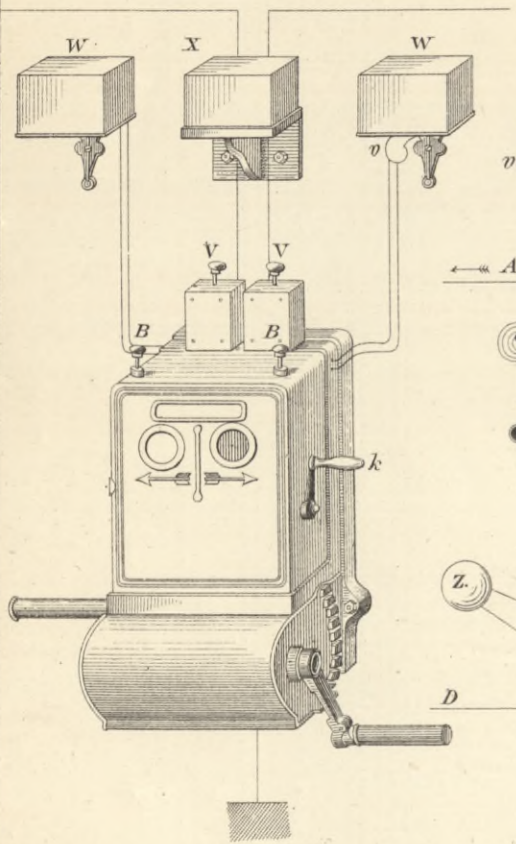


Fig 1. Bloktostel, systeem Siemens & Halske



Inwendige inrichting van het bloktostel (electrisch slot.) systeem Siemens & Halske.

Fig. 2 a-c.

Fig 2^a Toestand voor het blokkeeren.

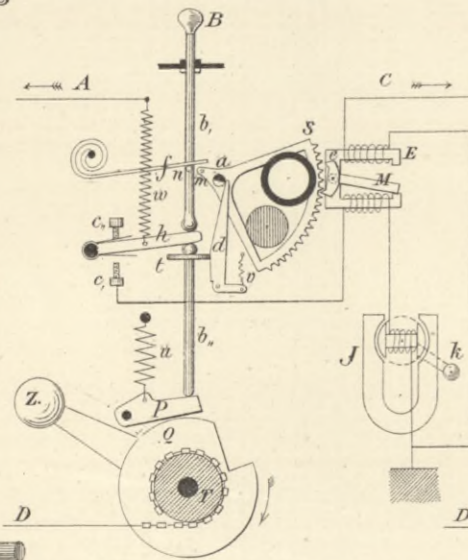


Fig 2^b Toestand tijdens het blokkeeren.

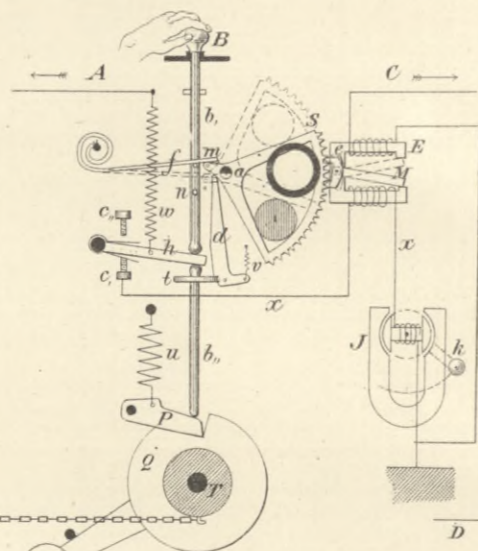


Fig 2^c Toestand na het blokkeeren.

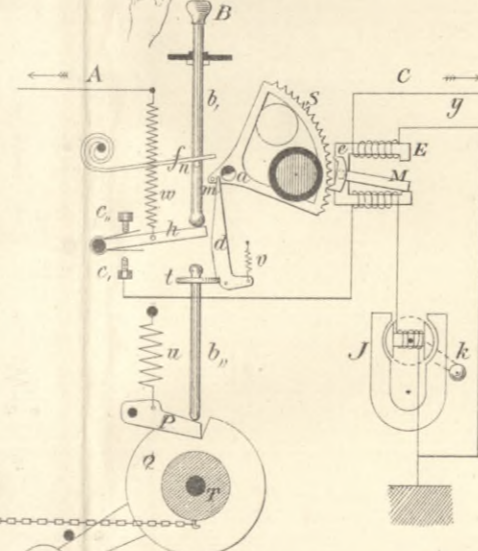


Fig. 3. Schematische voorstelling van den stroomloop in de bloktostellen met tweedeelig systeem.

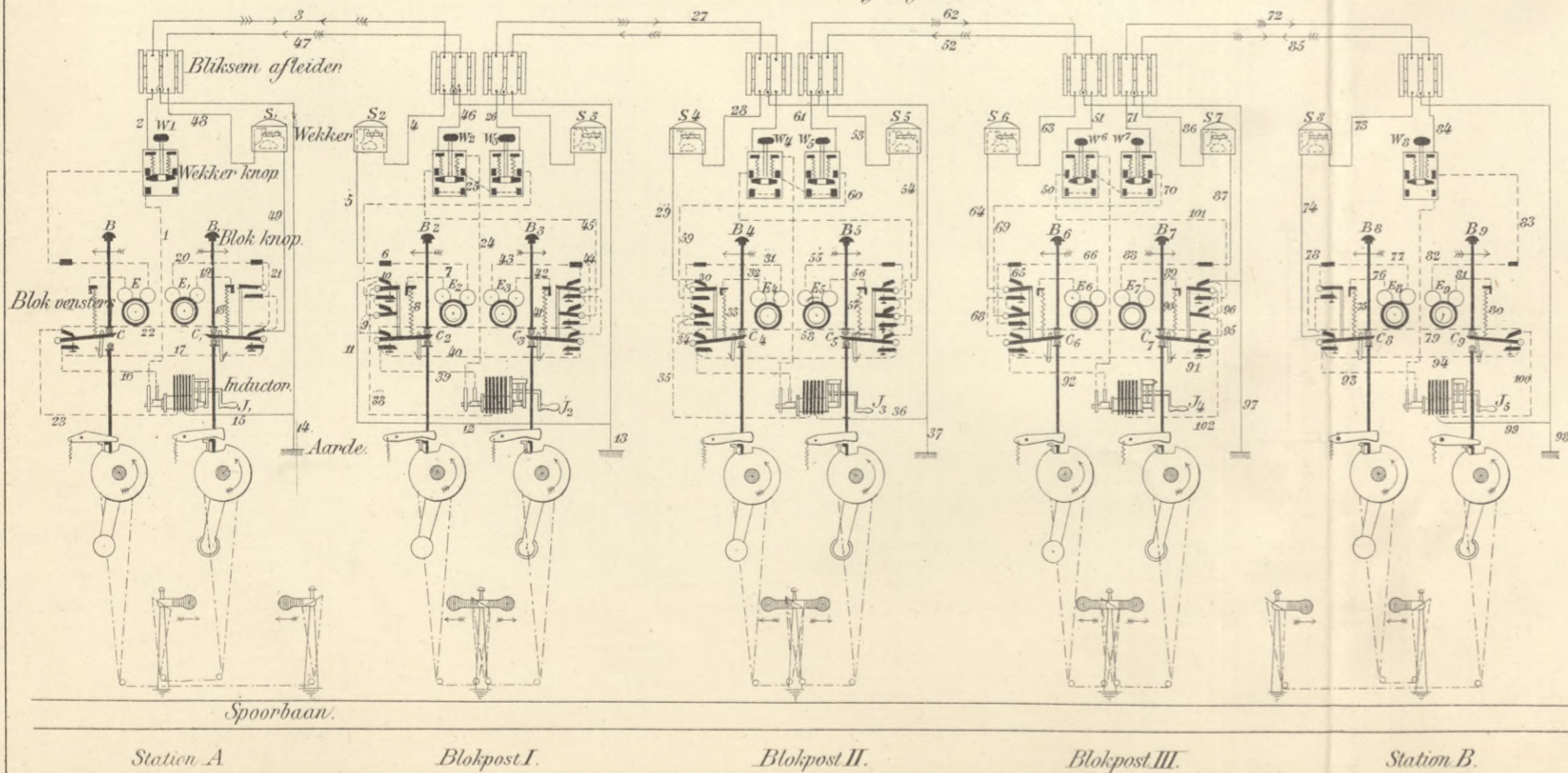
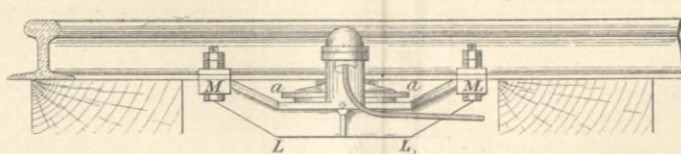


Fig. 6^a Zijaanzicht.



Kwik-contact Siemens & Halske. (Fig. 6^{a-b})

Fig. 6^b Dwarsdoorsnede.

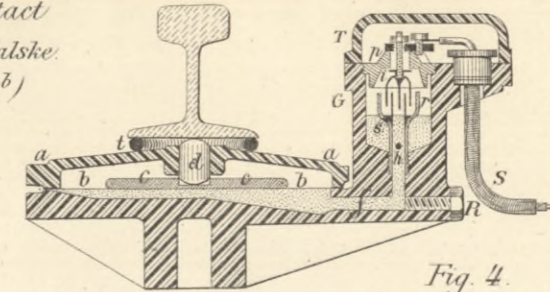


Fig. 5 Gewoon treincontact.

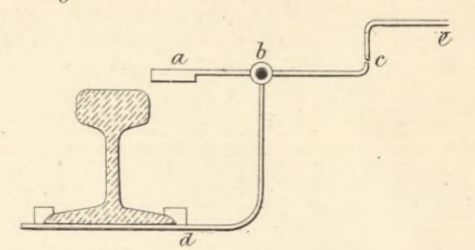


Fig. 4.

Verschillende gevallen van plaatsing der signalen in verband met de blokinrichtingen.

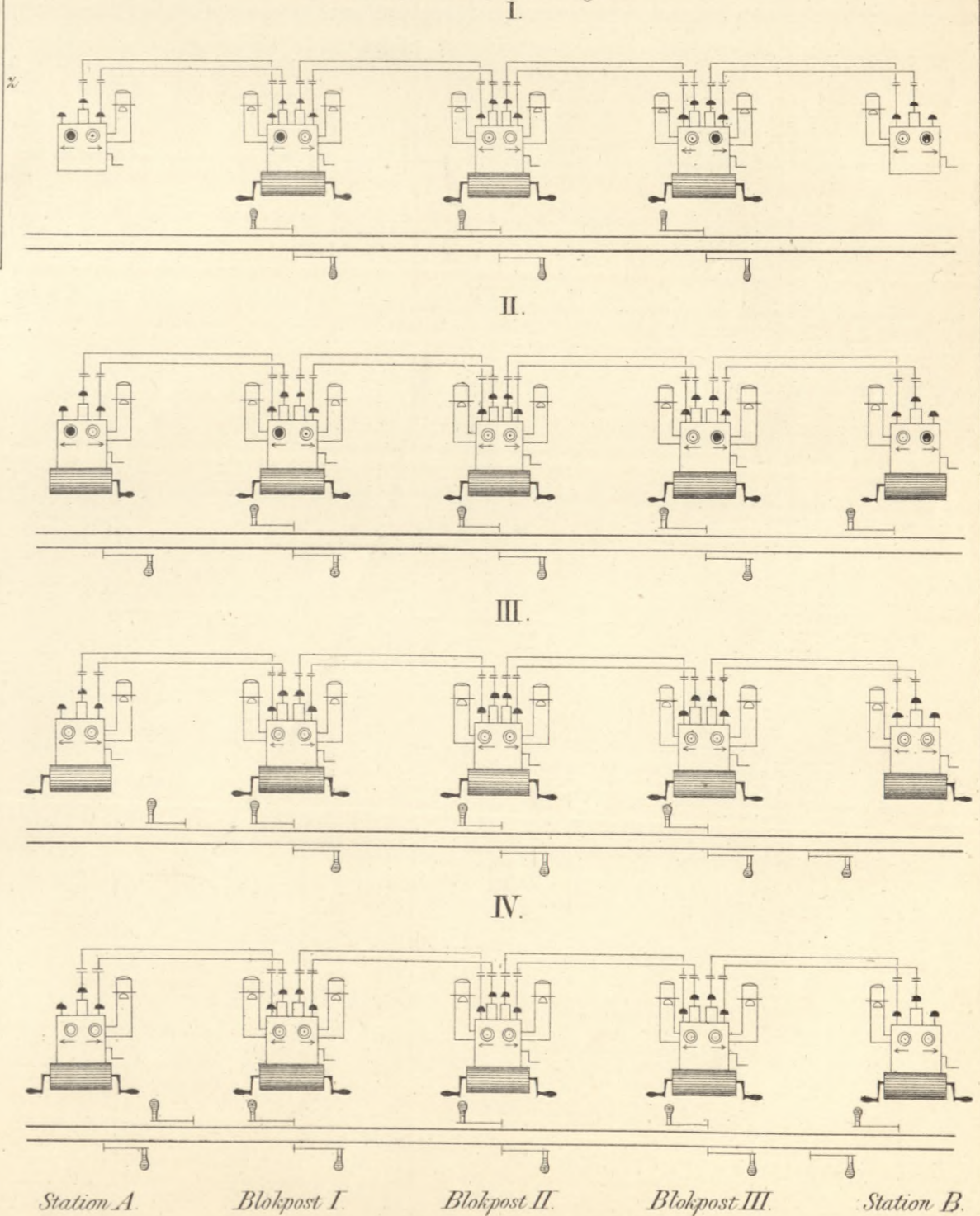


Fig. 1. Schematische voorstelling van de plaatsing van bloktoestellen tot beveiliging van het treinenverkeer op eene in vier secties verdeelde spoorweglijn, volgens het tweedeelig systeem van Siemens & Halske, met aanduiding van de bediening der toestellen tijdens den loop van een trein.

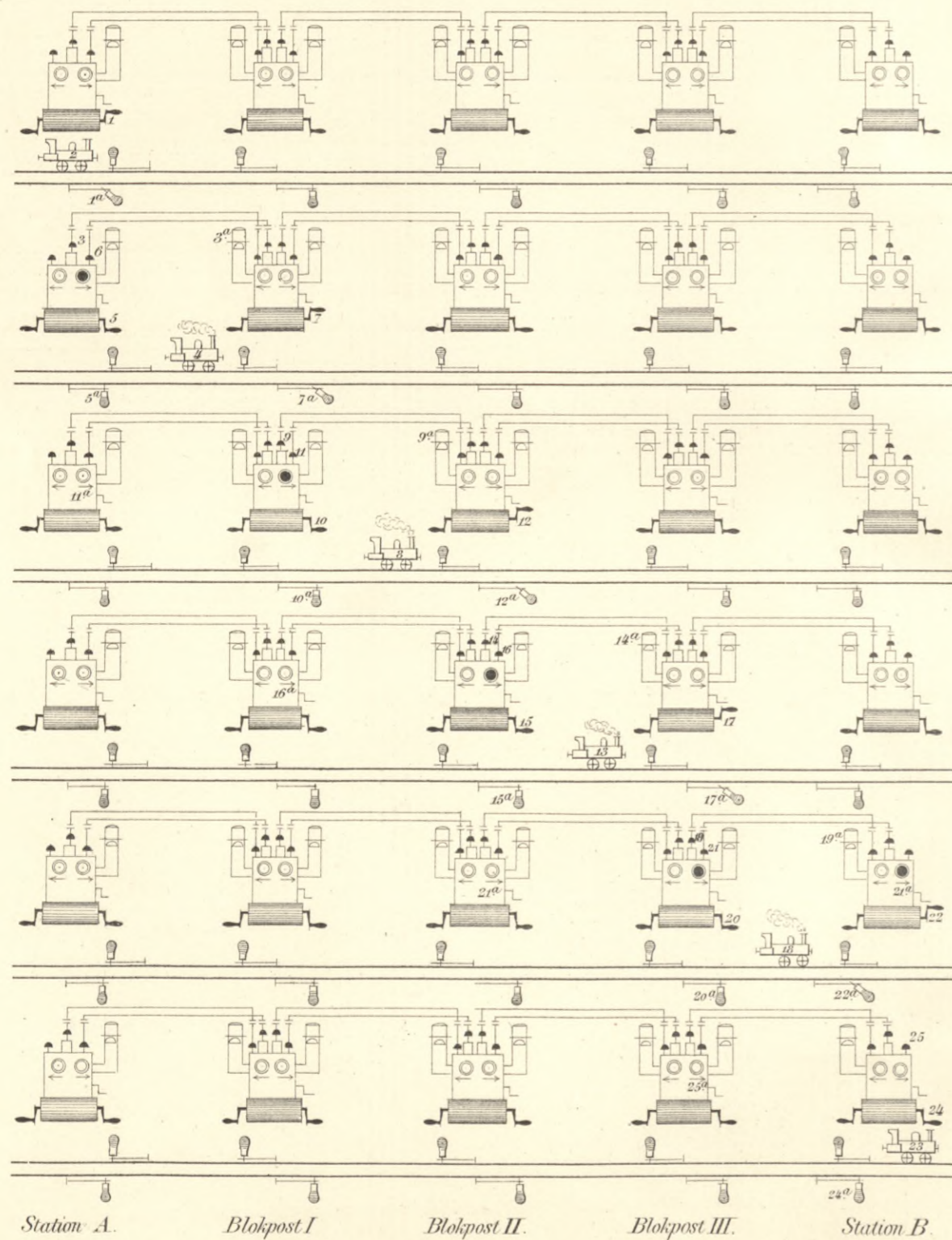
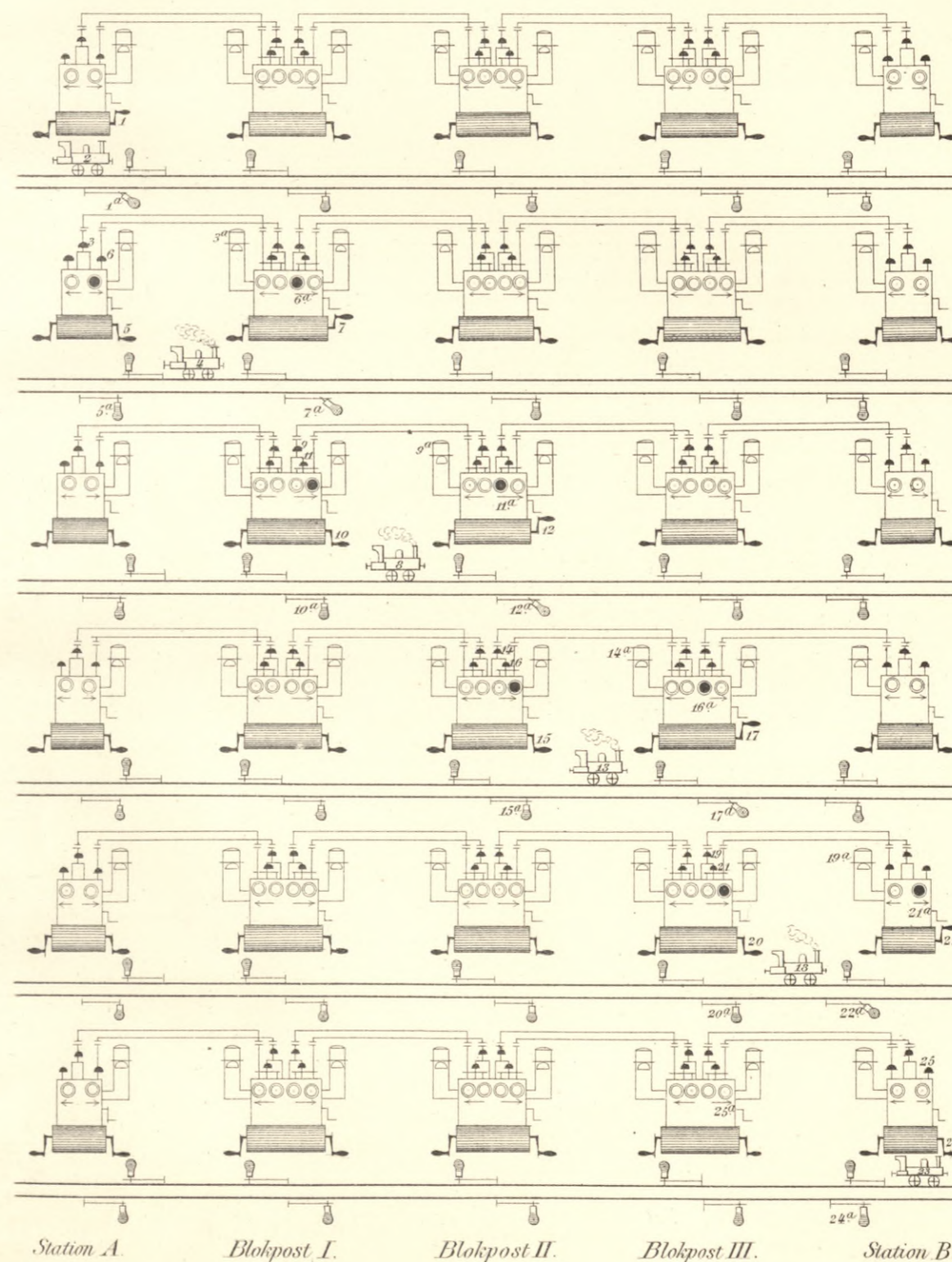


Fig. 2. Schematische voorstelling van de plaatsing van bloktoestellen tot beveiliging van het treinenverkeer op eene in vier secties verdeelde spoorweglijn, volgens het vierdeelig systeem van Siemens & Halske, met aanduiding van de bediening der toestellen tijdens den loop van een trein.



- Renvooi.**
- Handwissel,
 - id. met Clausslot en sper v recht spoor.
 - id. met centraal bediend grendel v krom spoor.
 - id. id. id. v recht spoor.
 - id. id. id. v recht en krom spoor.
 - Centraal bediend wissel norm. stand recht spoor.
 - id. id. id. krom spoor.
 - id. id. met druklat, id. recht spoor.
 - - - - - Onteigeningsgrens,
 - + + + + + Afrastering.

Fig. 2. Stationsemplacement Apeldoorn.

Langteschaal 1:2000. Breedteschaal 1:1000.

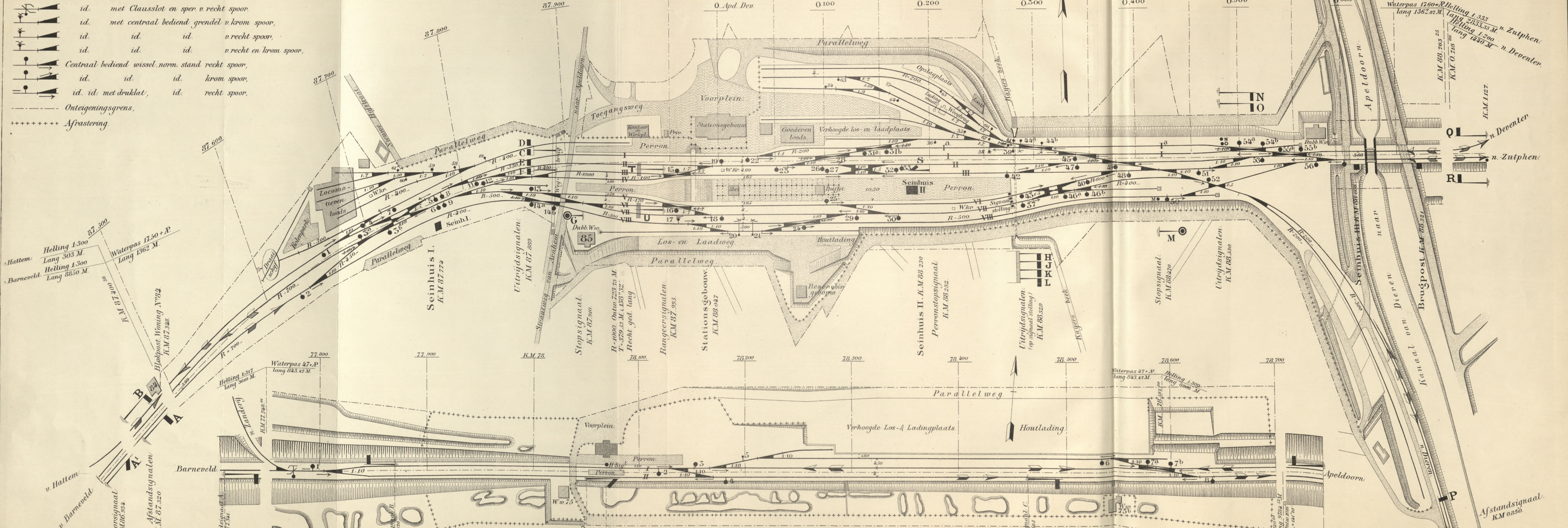


Fig. 1. Stationsemplacement Assel.

Langteschaal 1:2000. Breedteschaal 1:1000.



Fig. 1. Normaal profiel voor ijzeren rails nat. grootte.

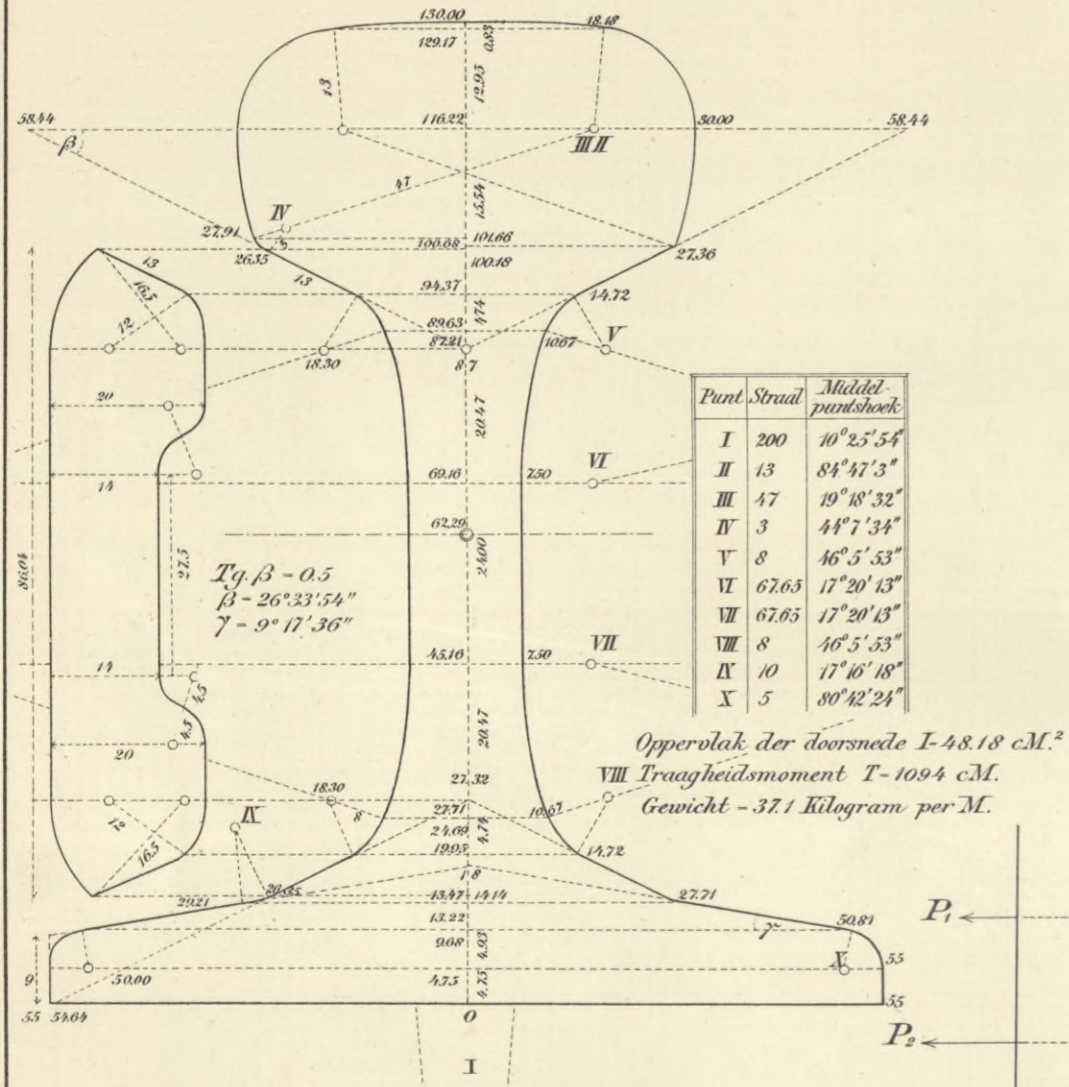


Fig. 6.

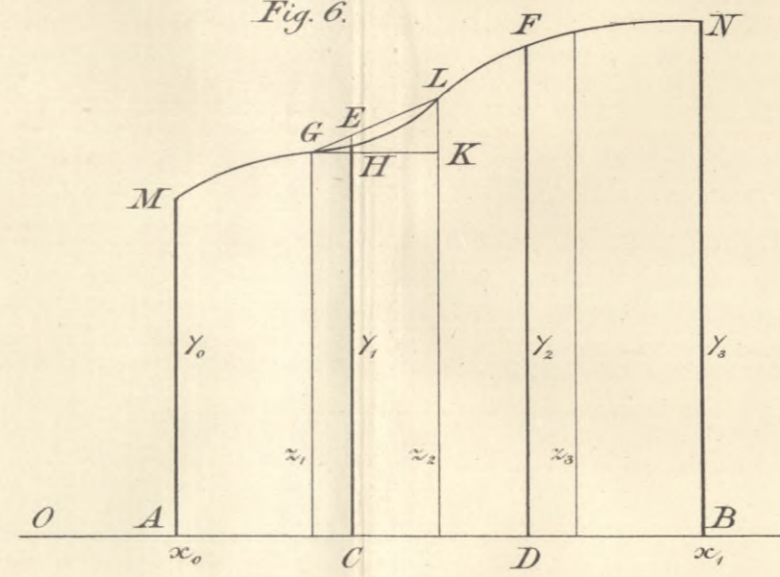


Fig. 2. Normaal profiel voor stalen rails. nat. grootte.

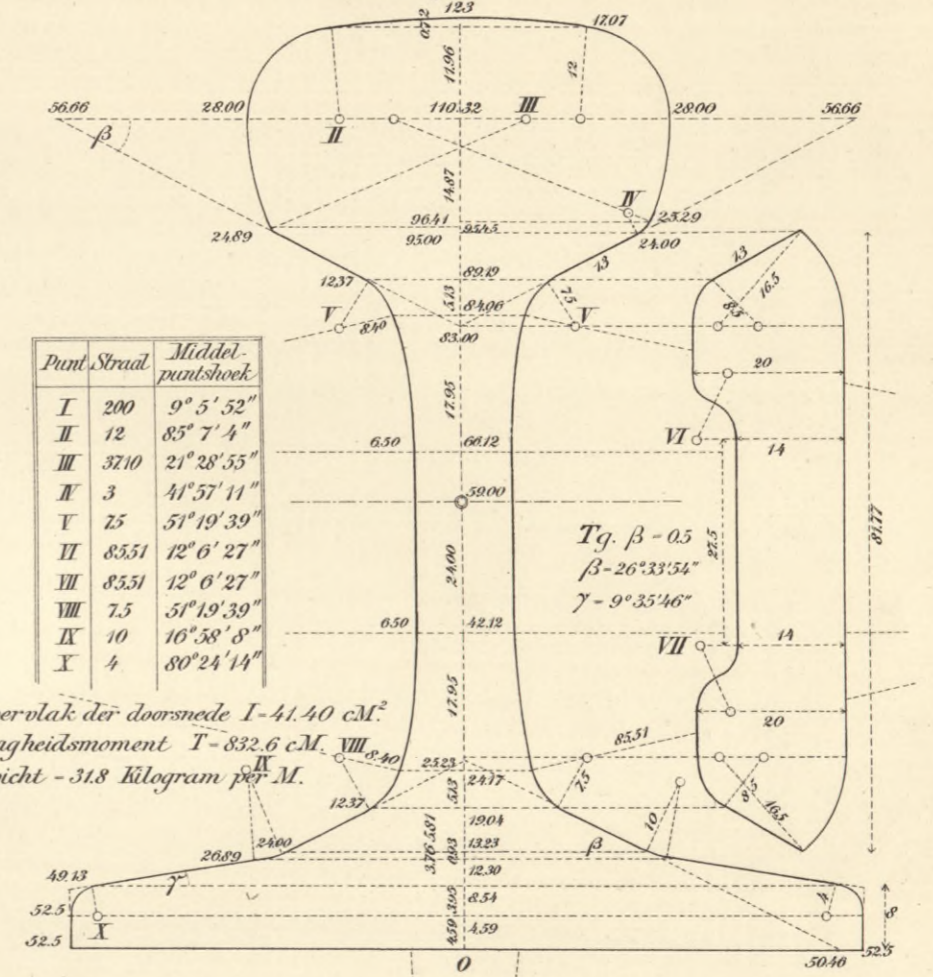


Fig. 7.

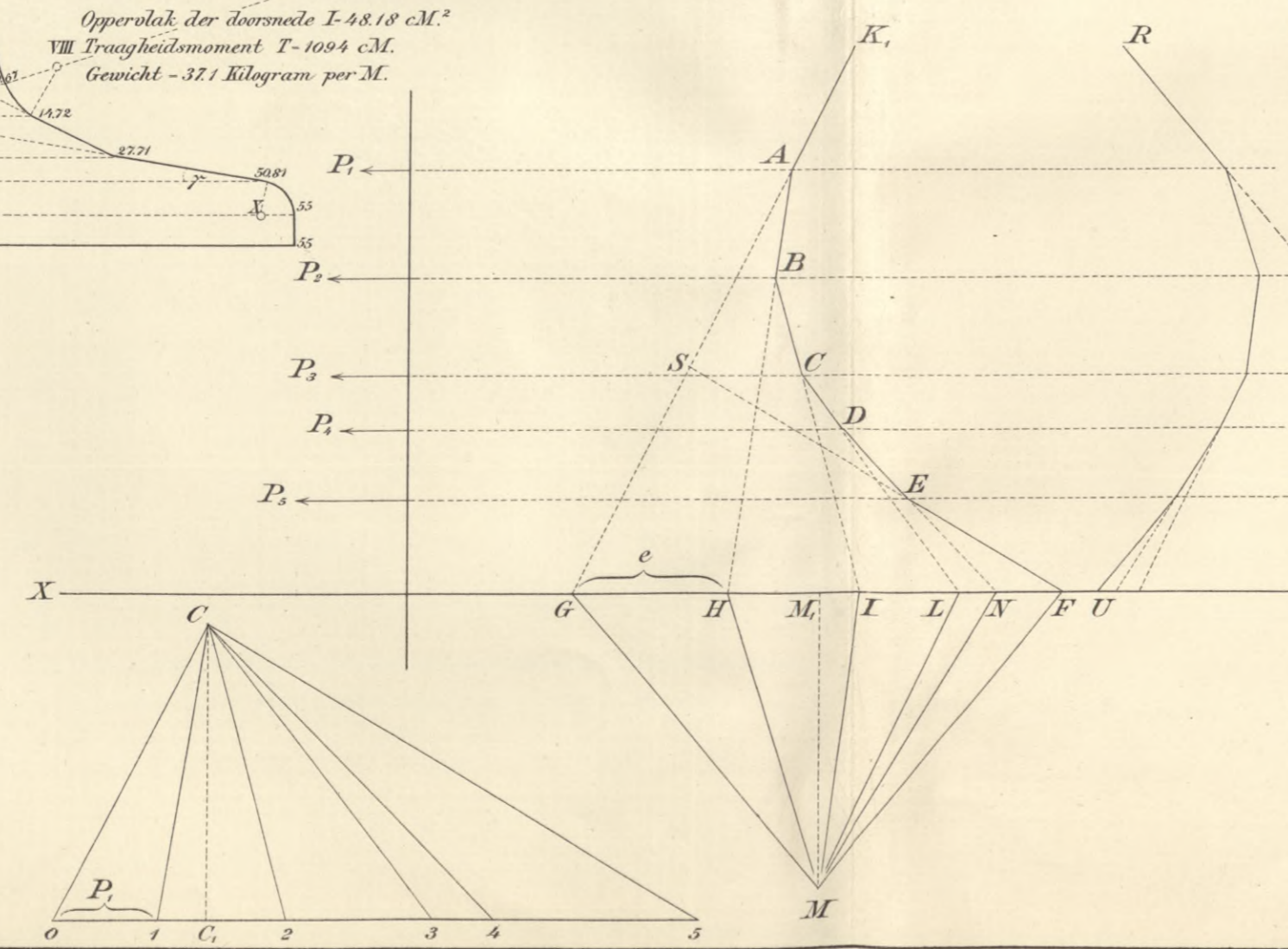


Fig. 3.

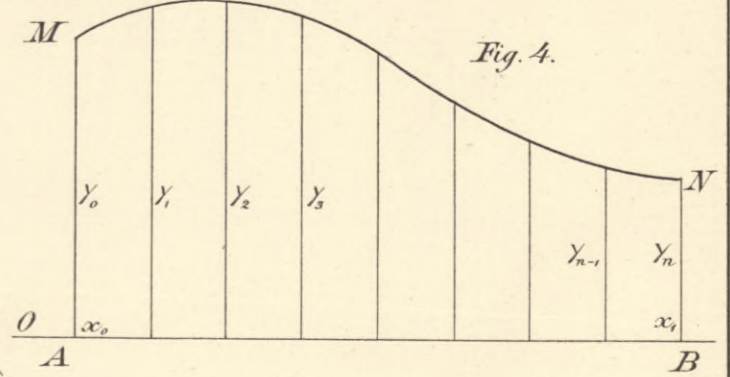
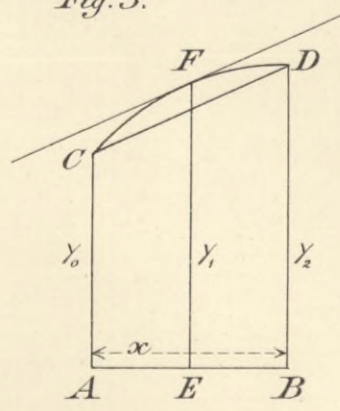
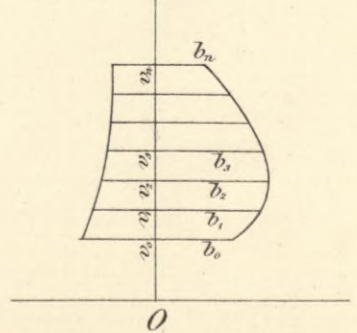
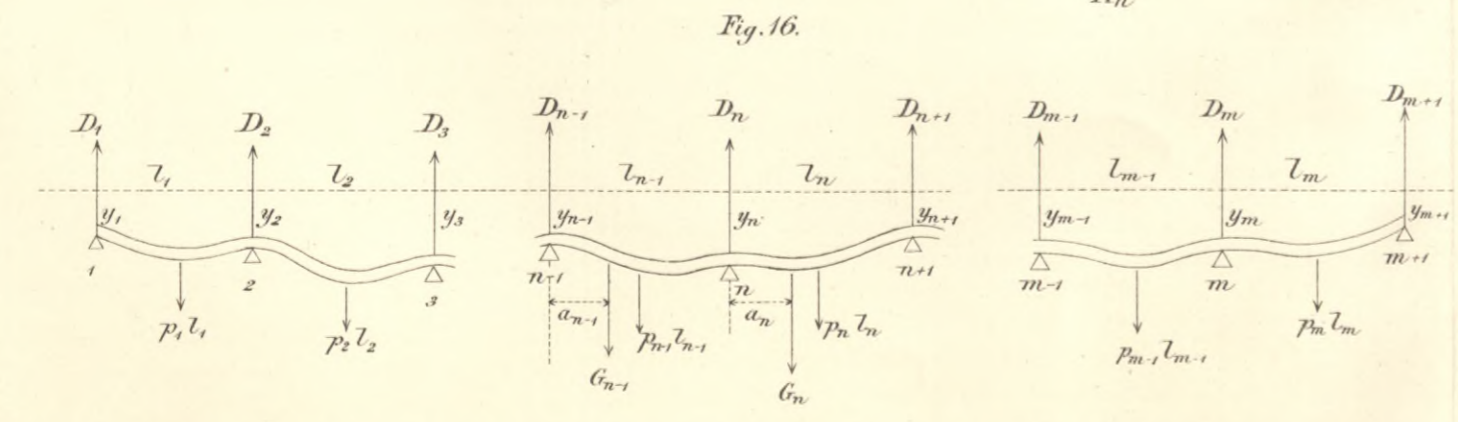
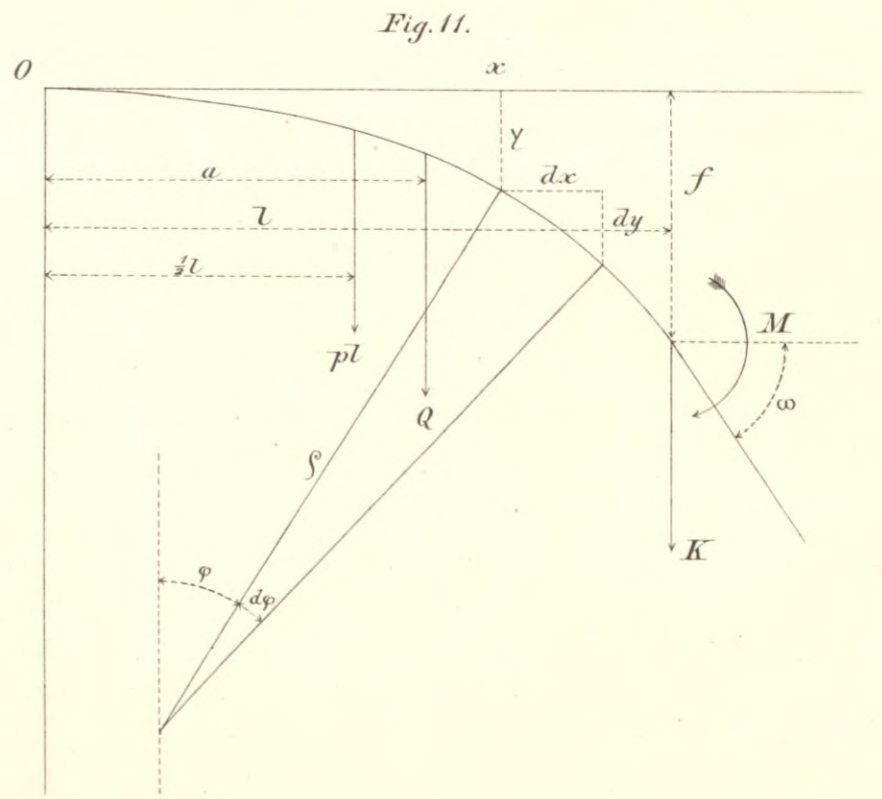
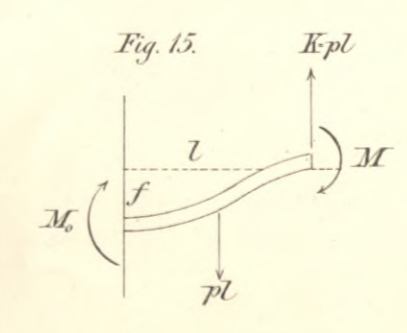
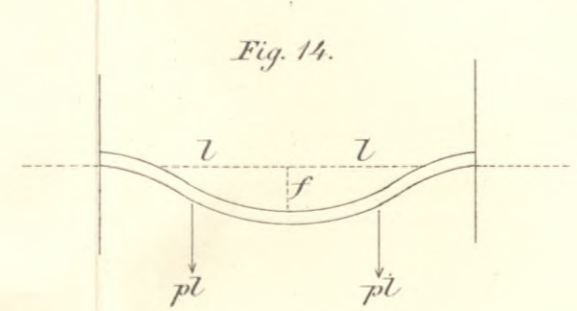
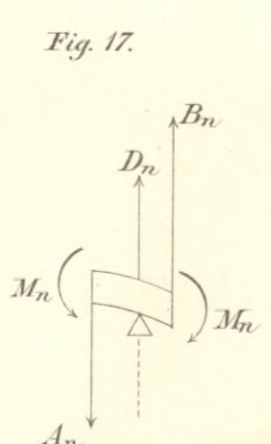
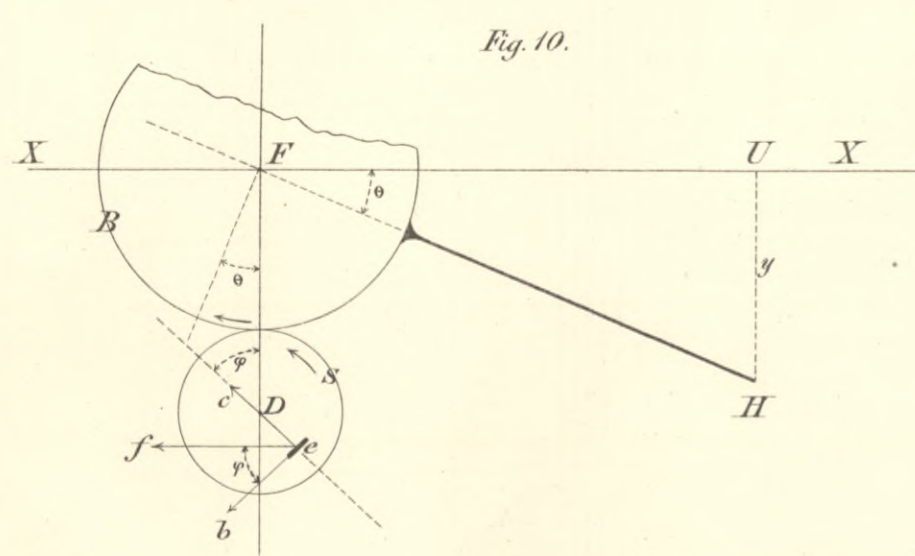
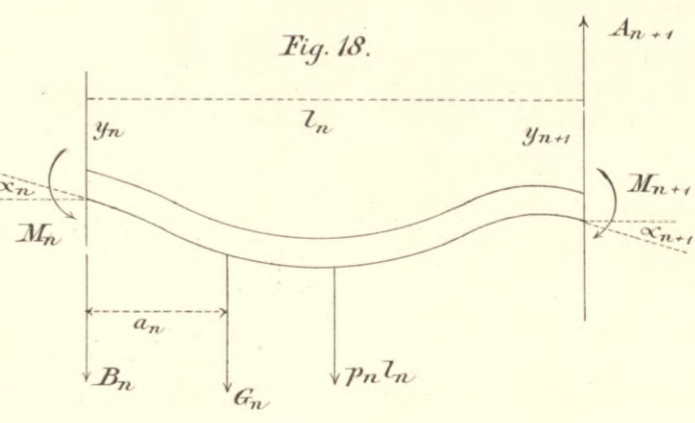
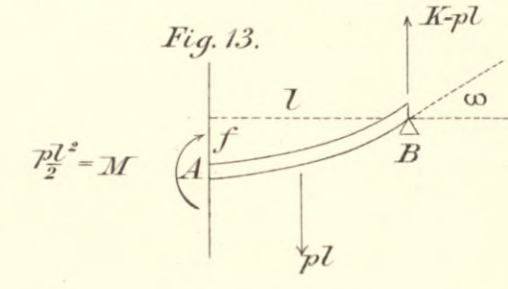
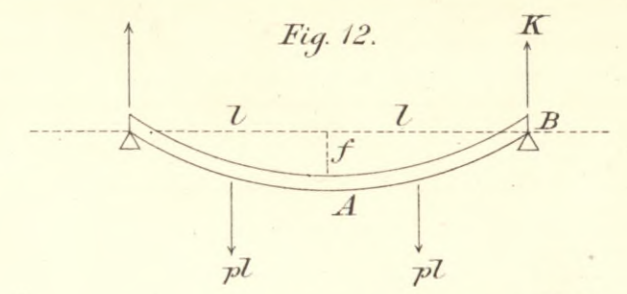
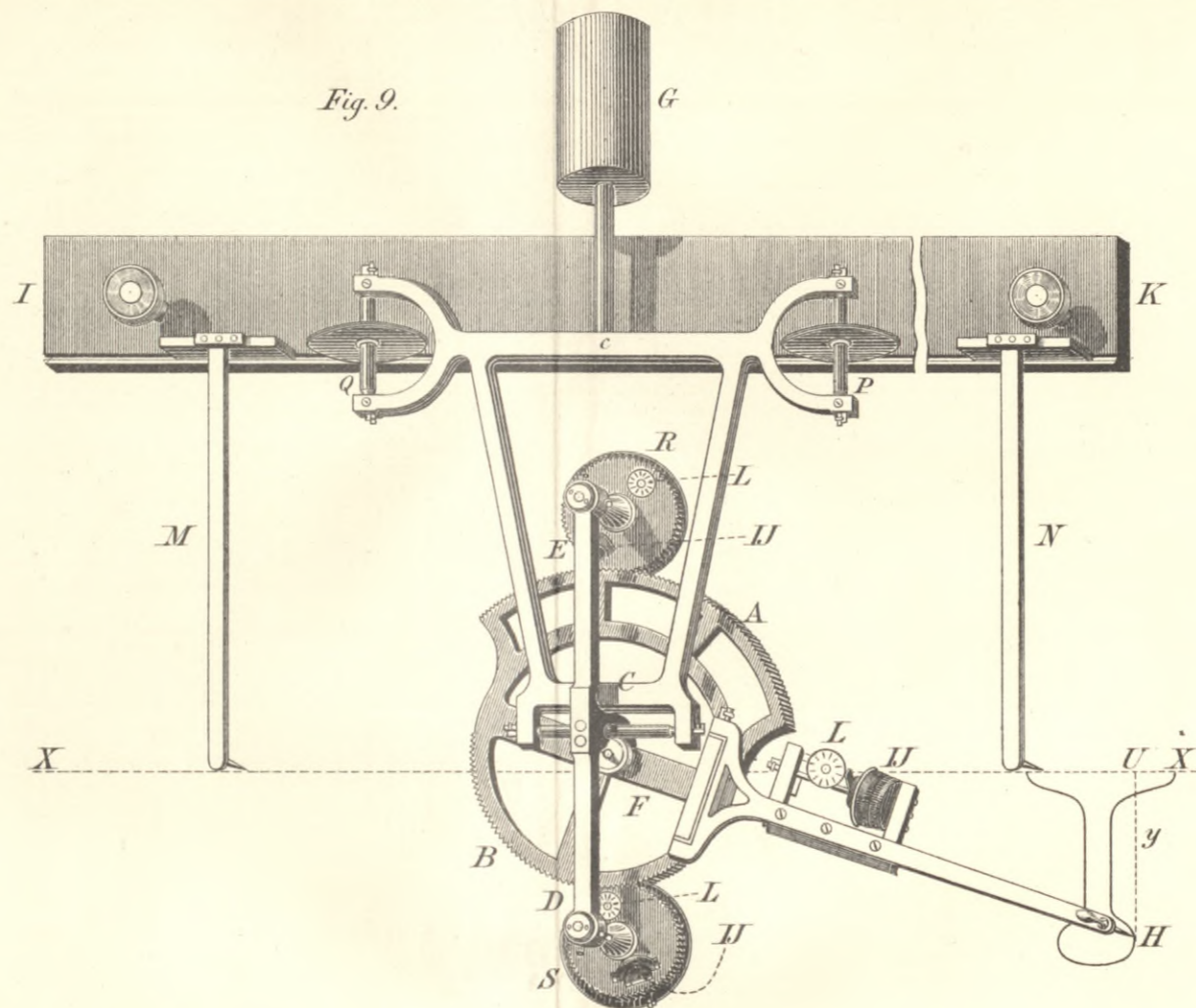
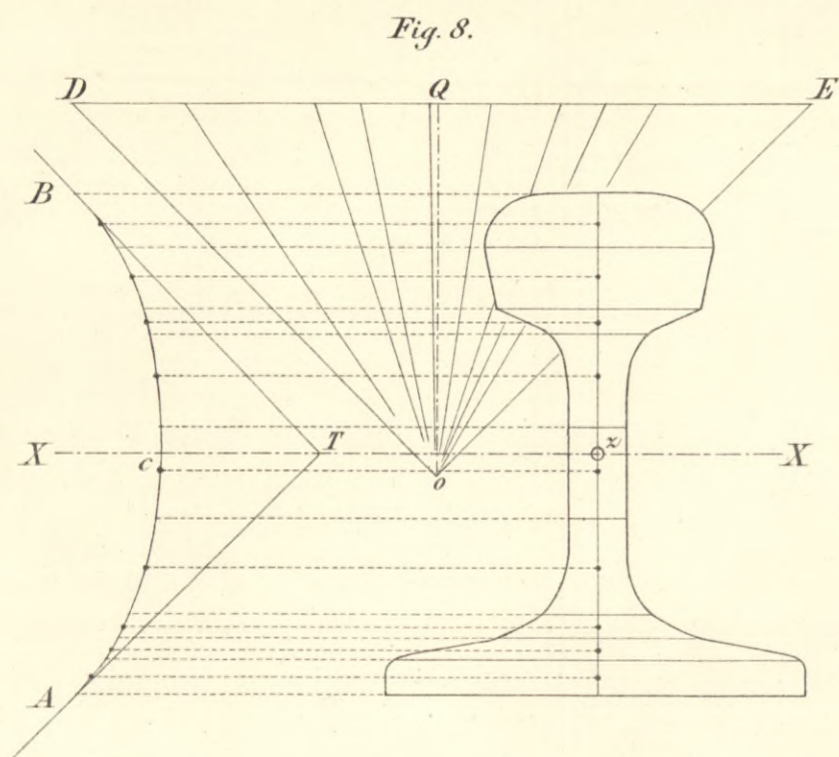


Fig. 5.





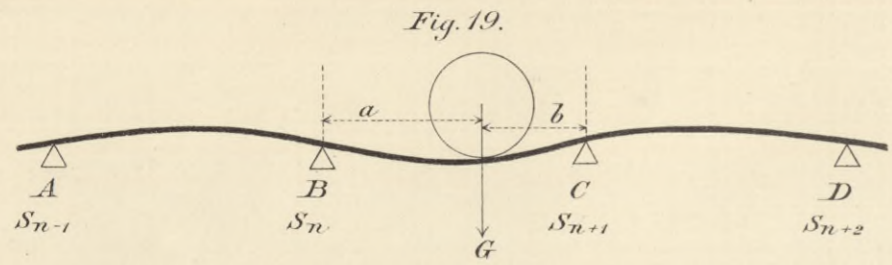


Fig. 19.

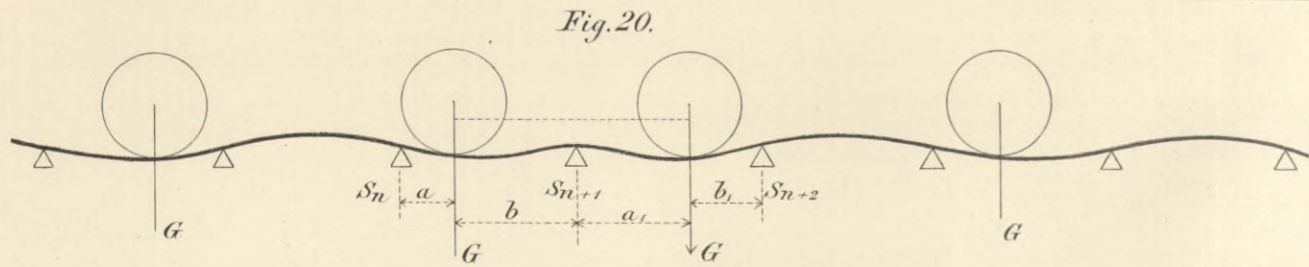


Fig. 20.

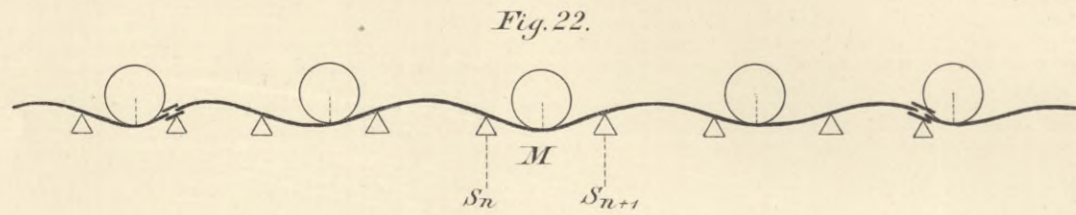


Fig. 22.

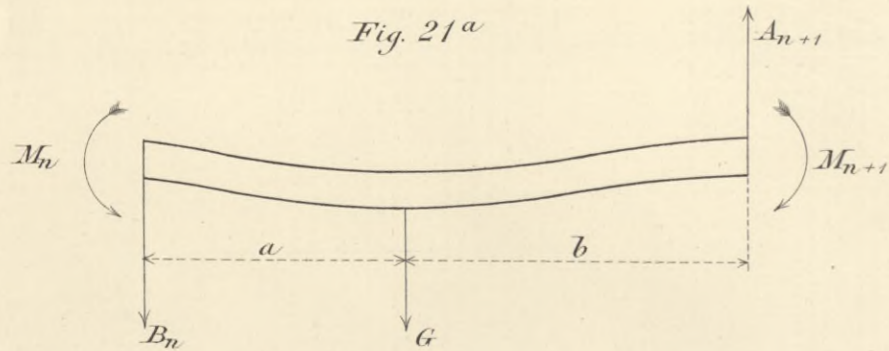


Fig. 21a

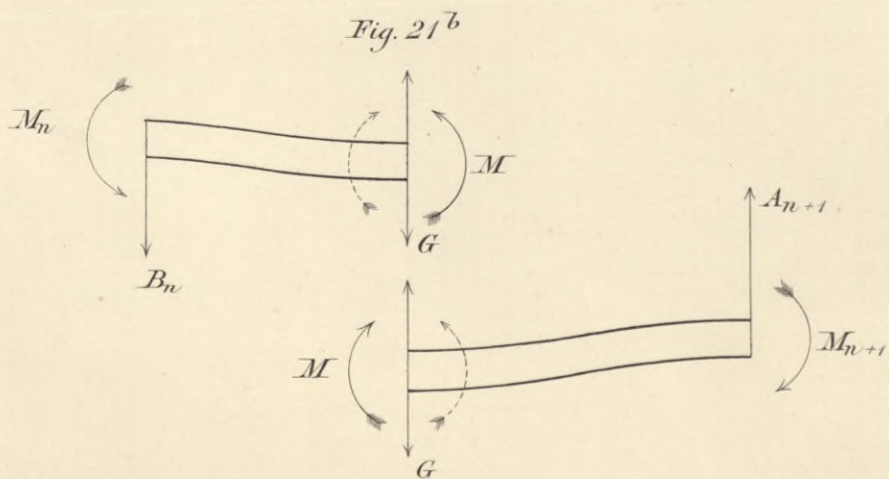


Fig. 21b

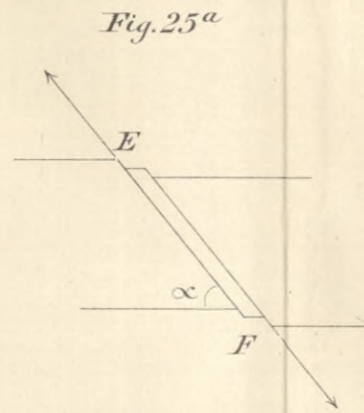


Fig. 25a

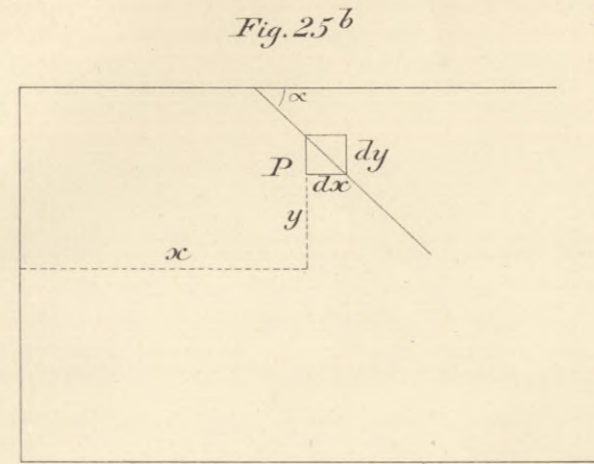


Fig. 25b

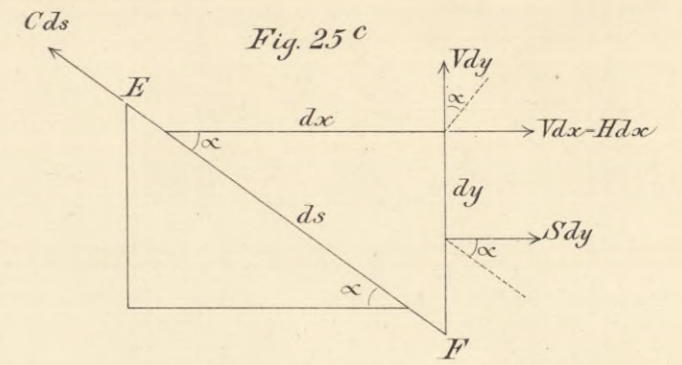


Fig. 25c

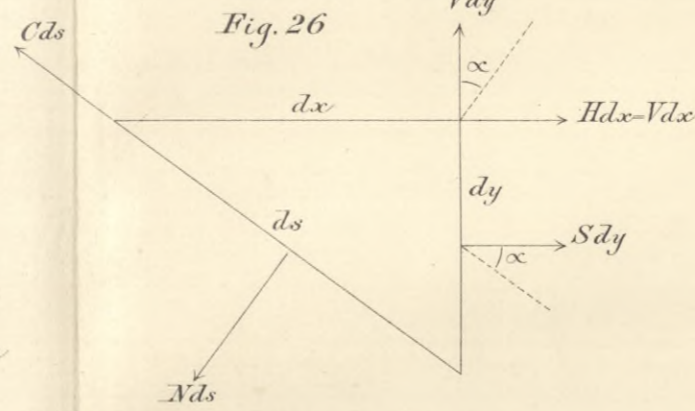


Fig. 26

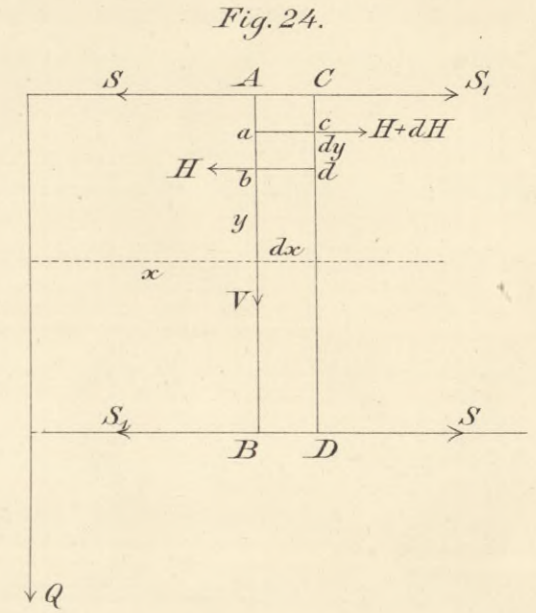


Fig. 24.

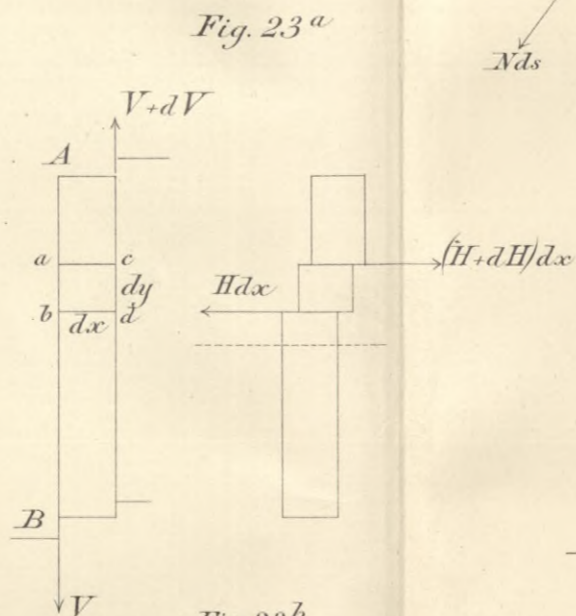


Fig. 23a

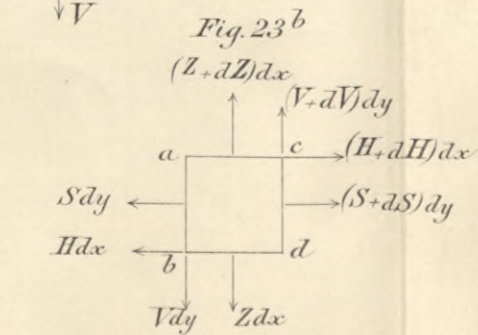


Fig. 23b

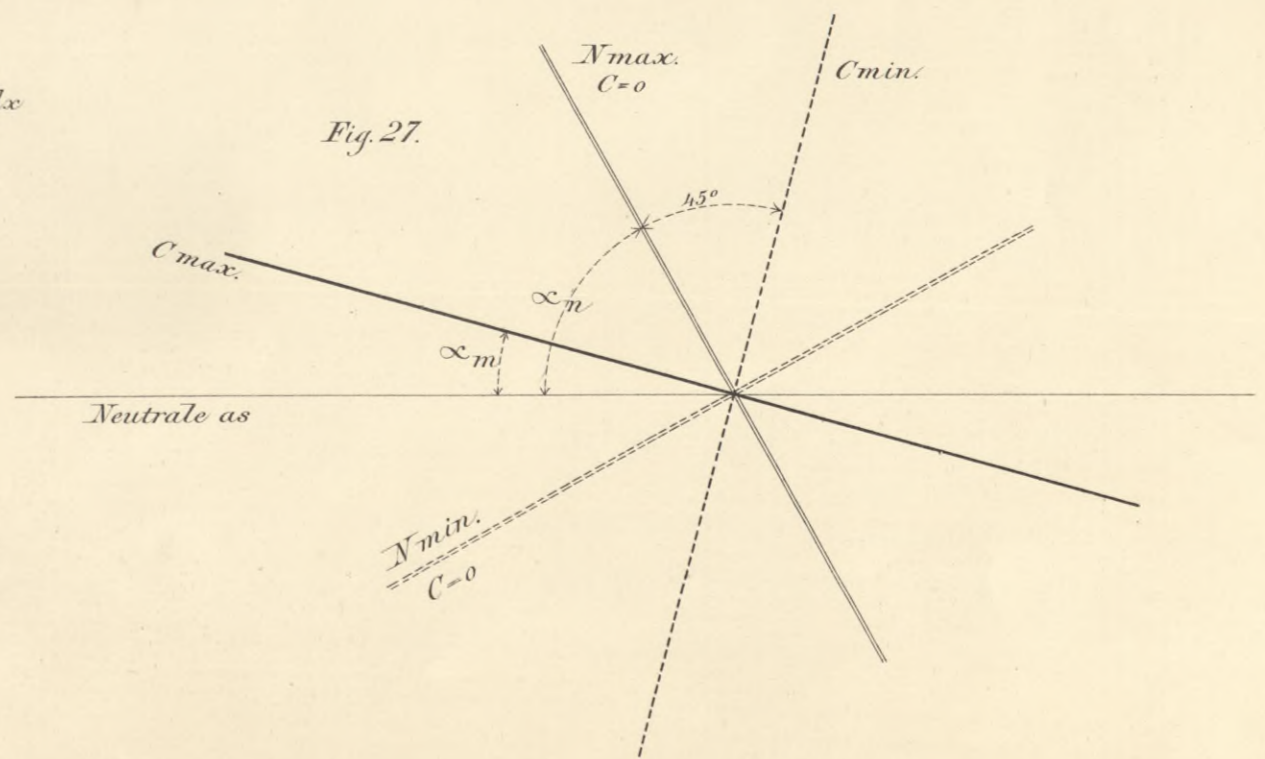


Fig. 27.

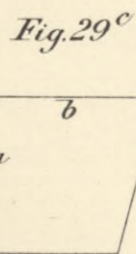
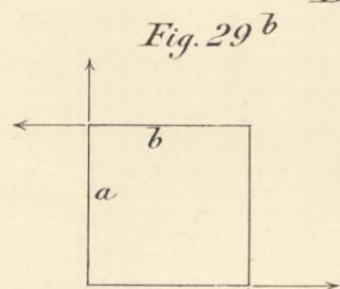
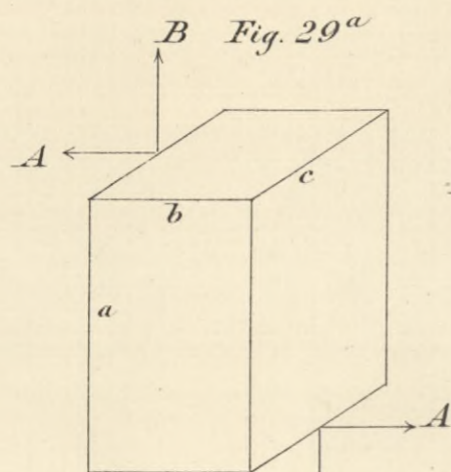
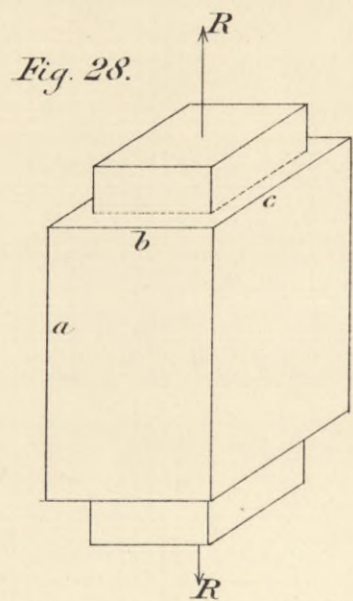


Fig. 30.

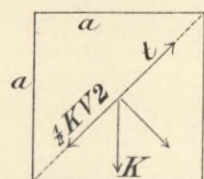


Fig. 31.

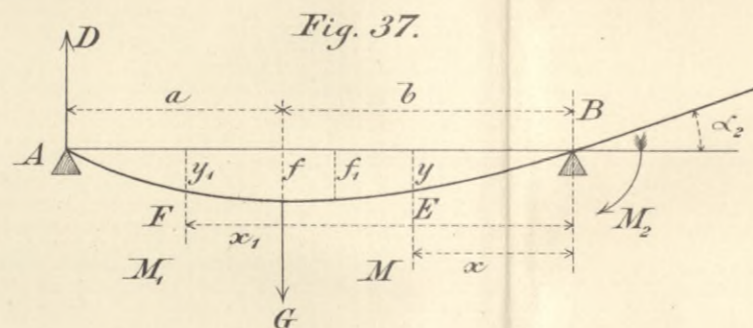
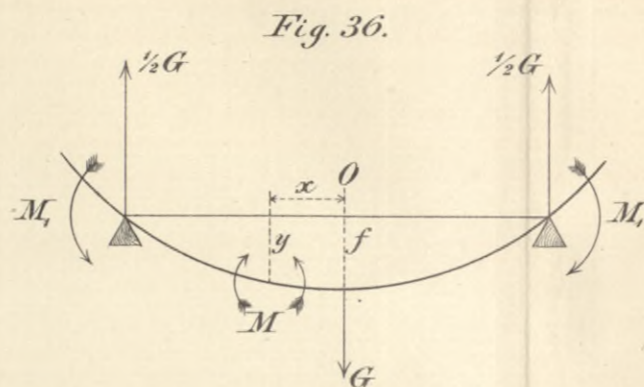
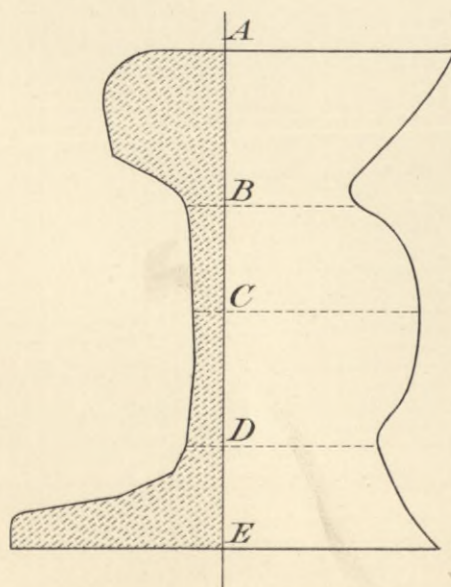


Fig. 38.

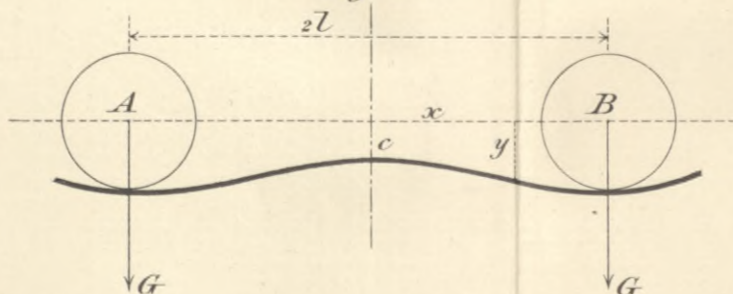


Fig. 33.

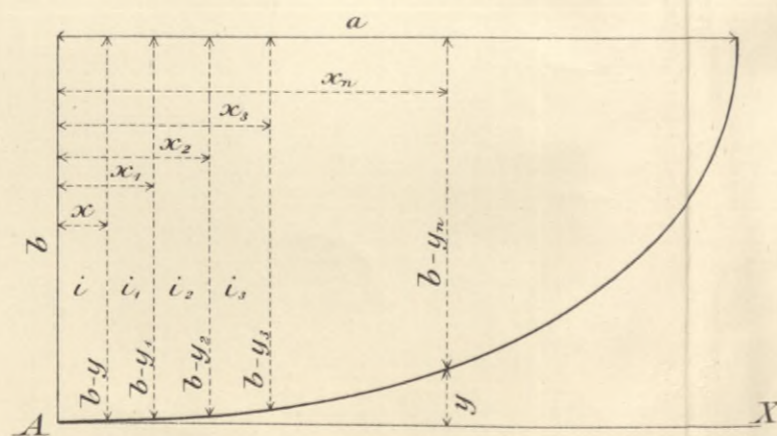


Fig. 32.

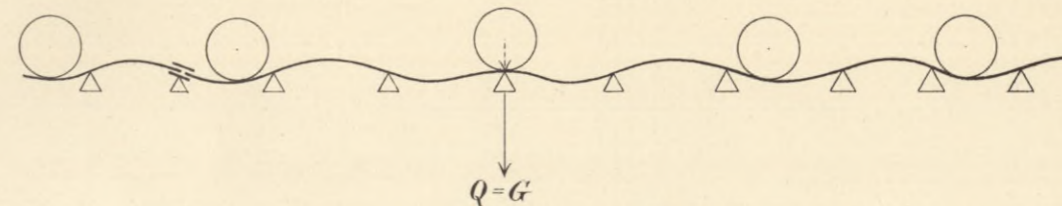


Fig. 34.

Weren rails (Oud profiel Nordbahn)

Max a = 20.9

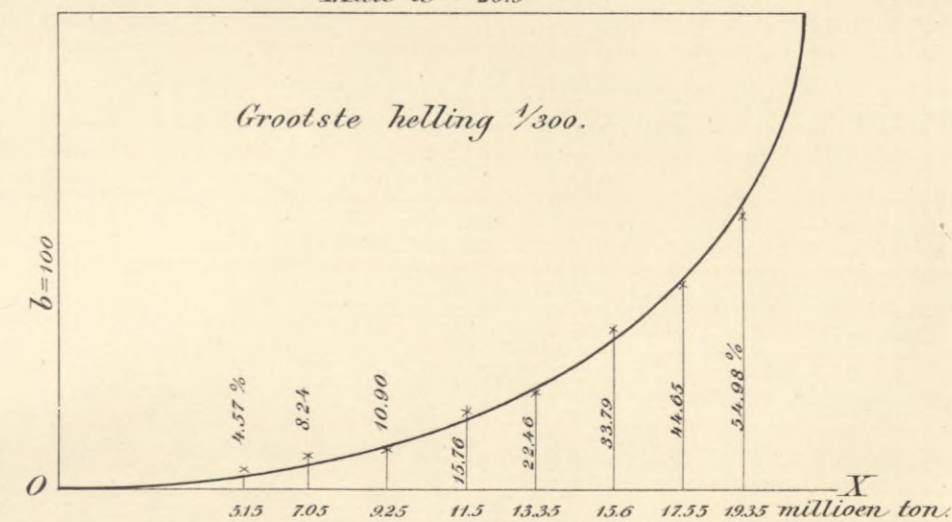


Fig. 35.

Stalen rails (Nieuw profiel Nordbahn)

Max a = 83.95

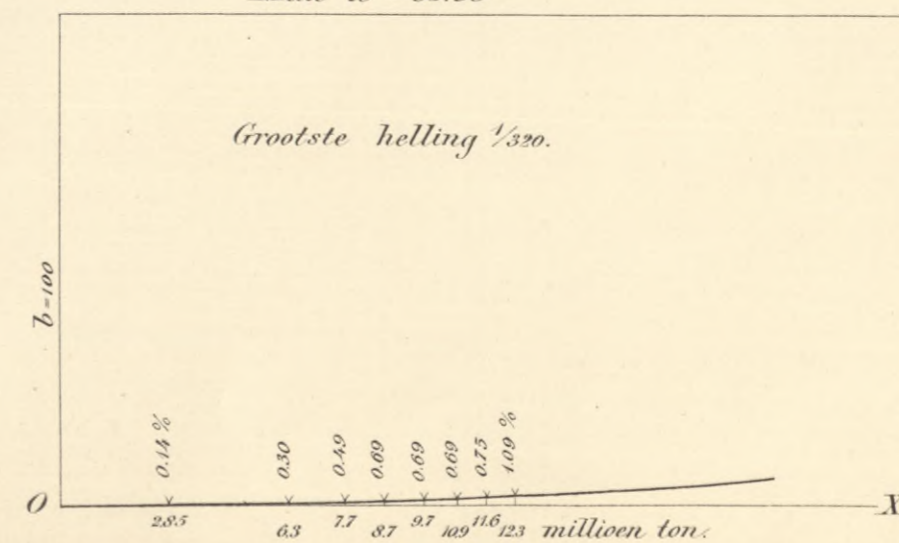


Fig. 39.

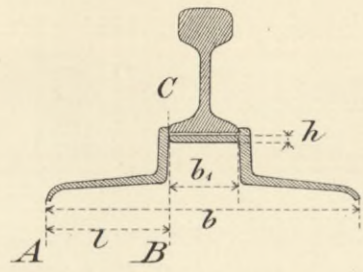


Fig. 43.

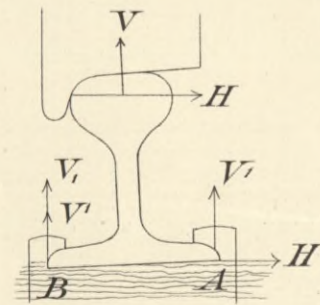


Fig. 40.

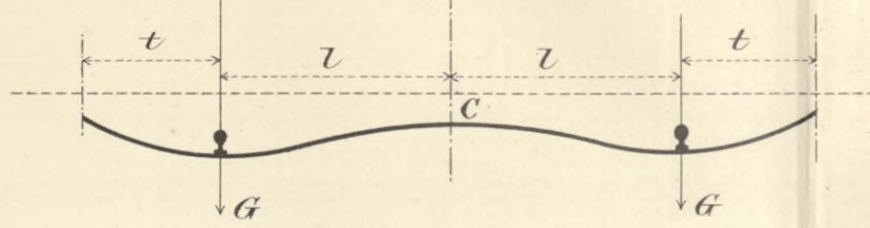


Fig. 41.

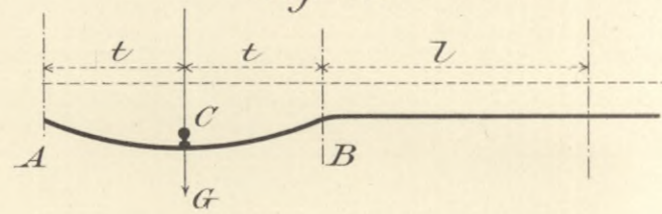


Fig. 44.

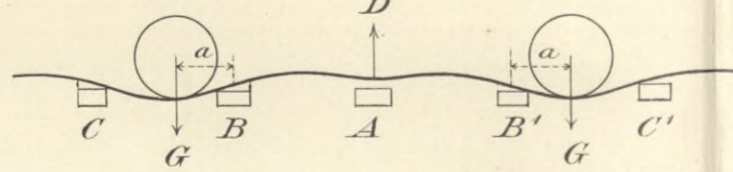


Fig. 42.

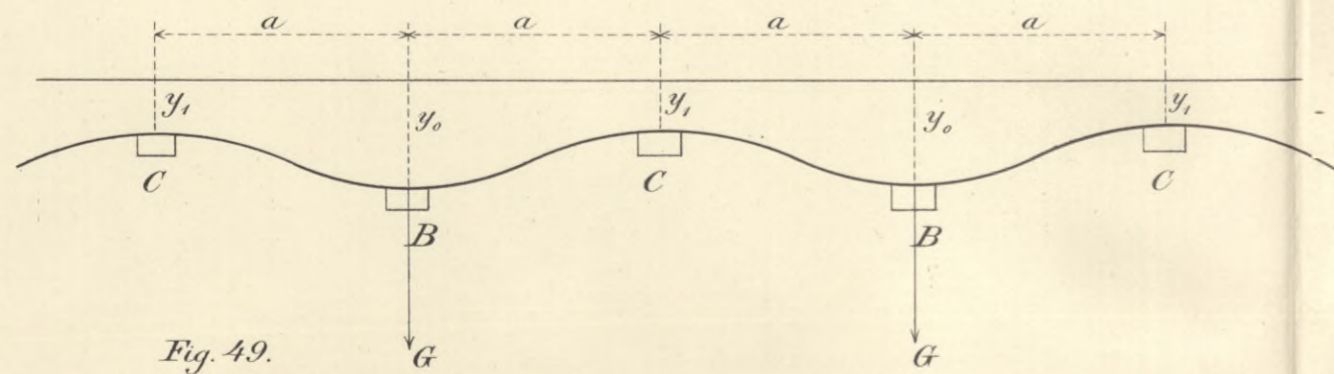


Fig. 49.

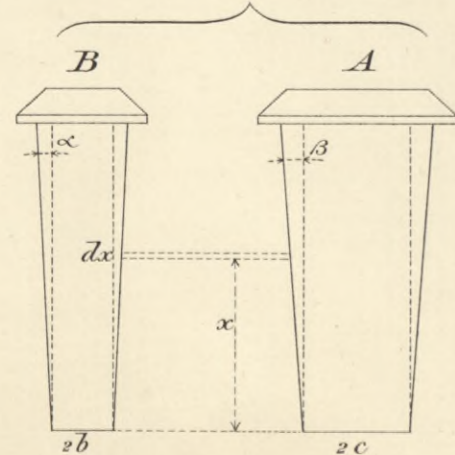


Fig. 50.

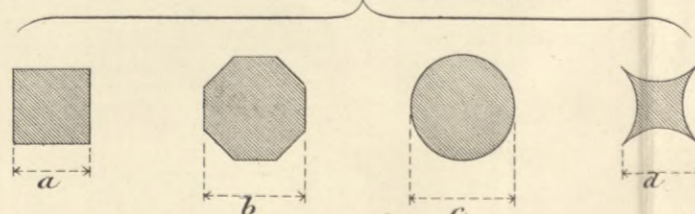


Fig. 45.

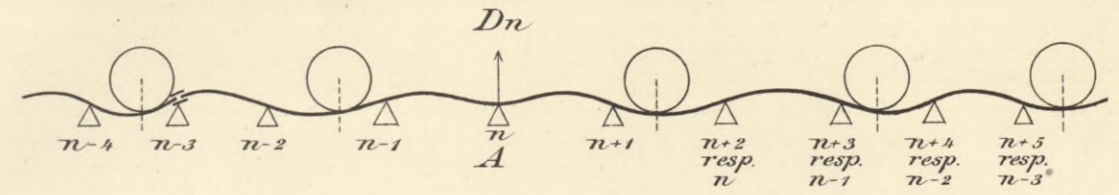


Fig. 46.

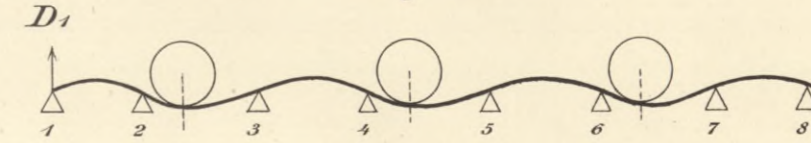


Fig. 47.

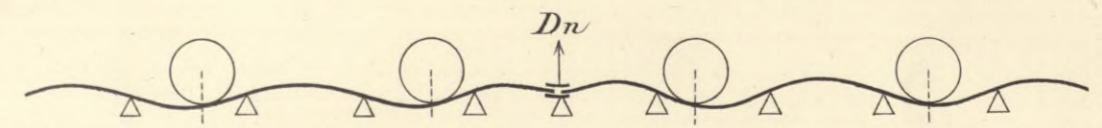


Fig. 48.

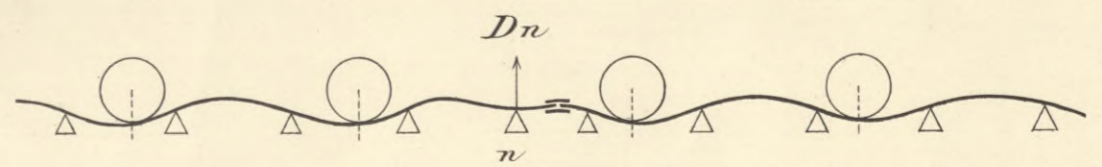
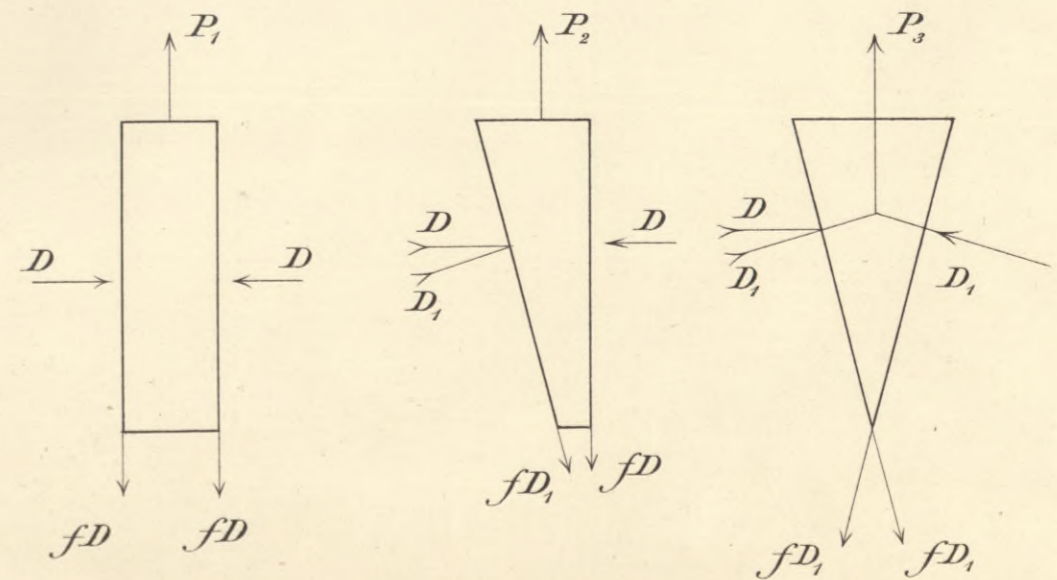
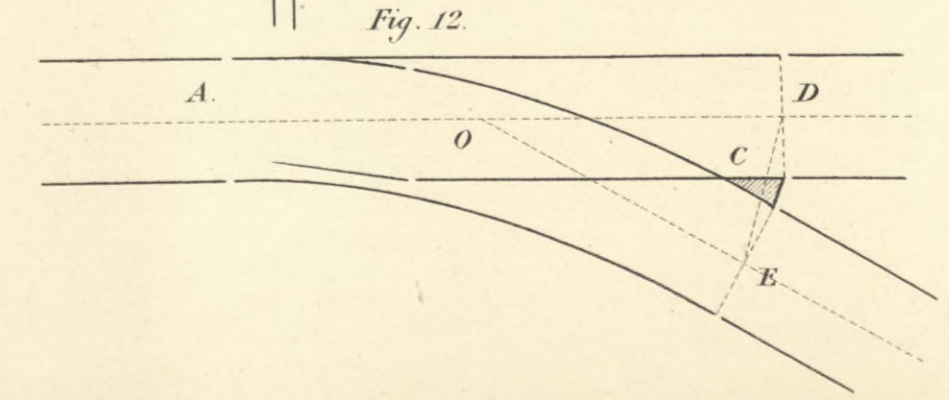
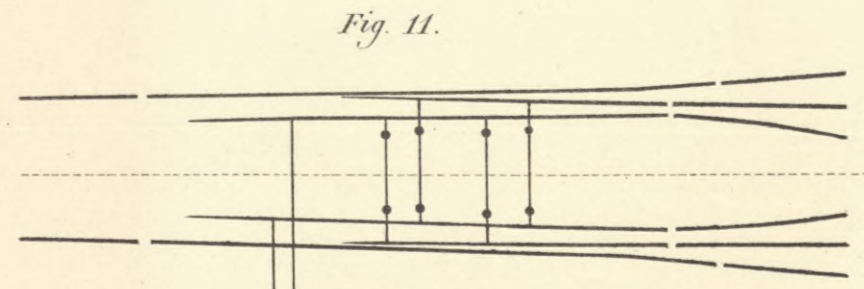
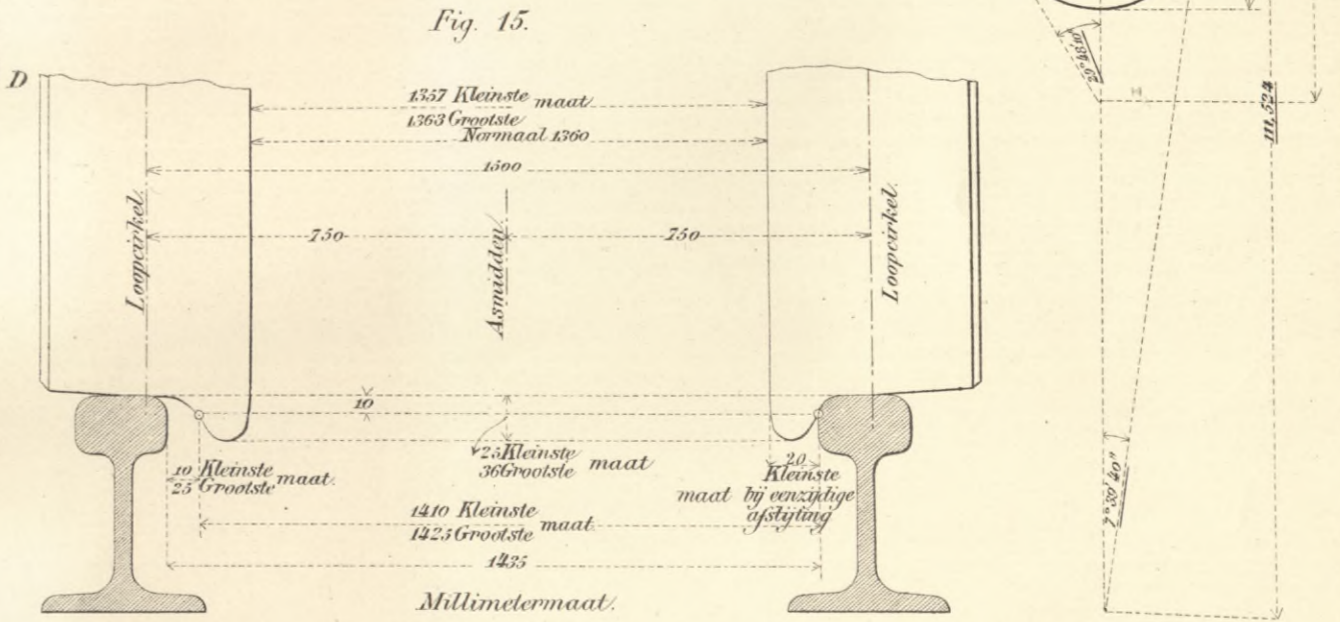
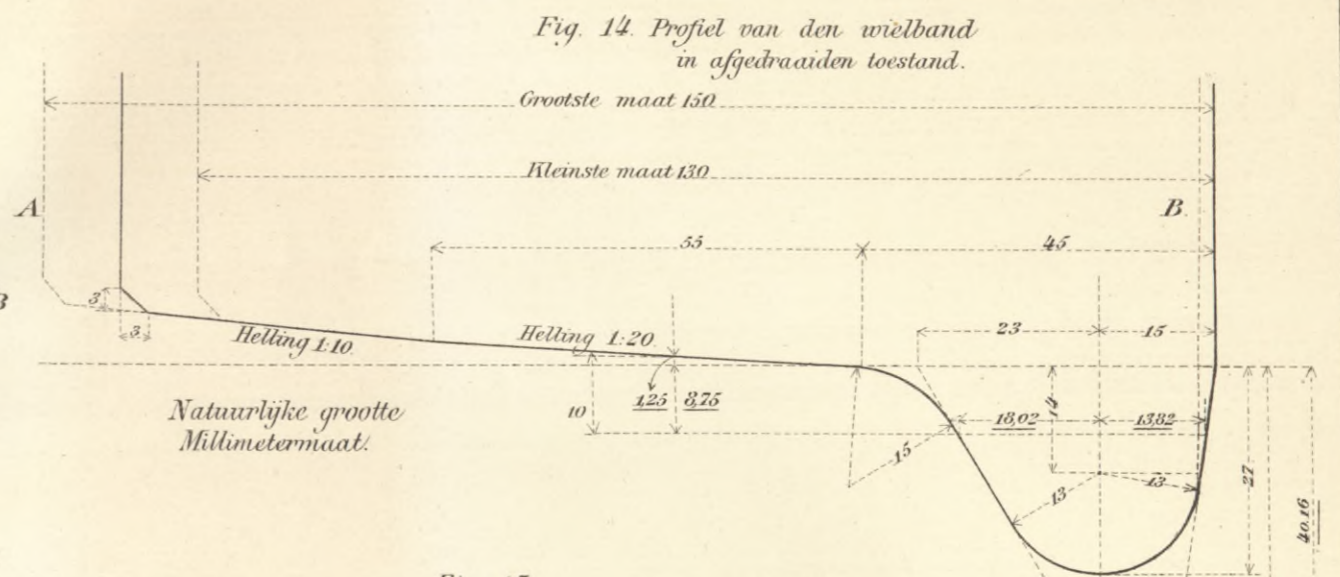
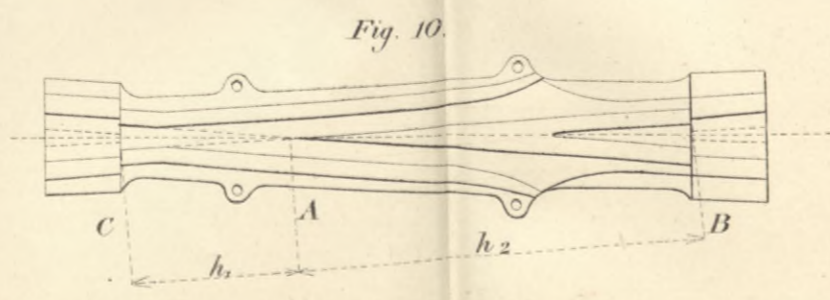
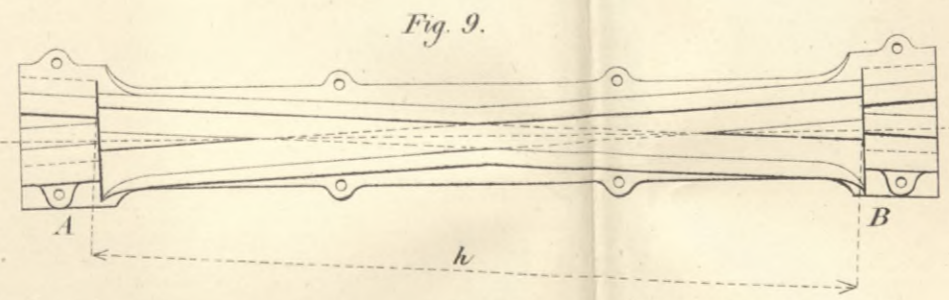
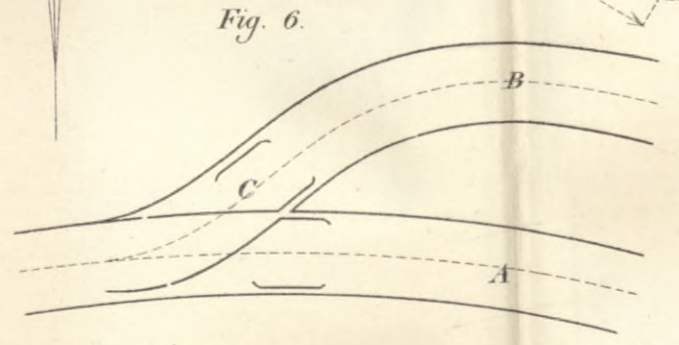
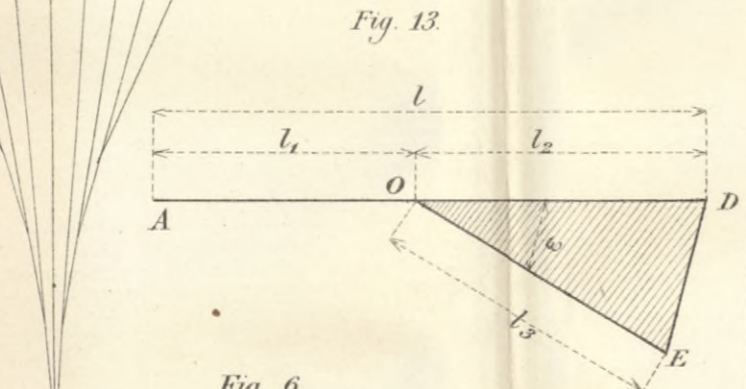
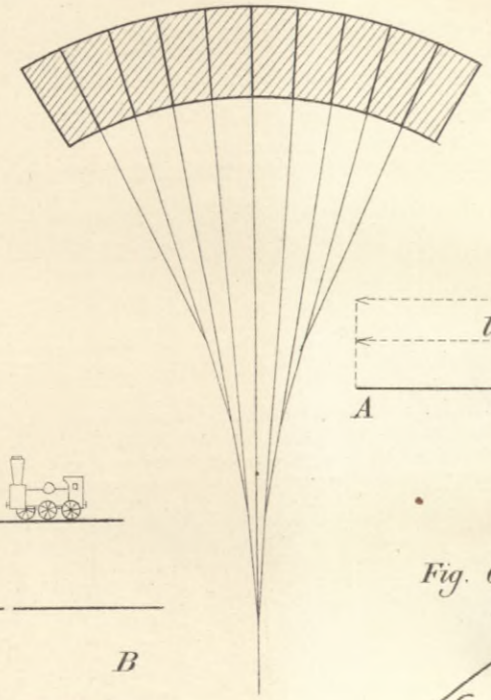
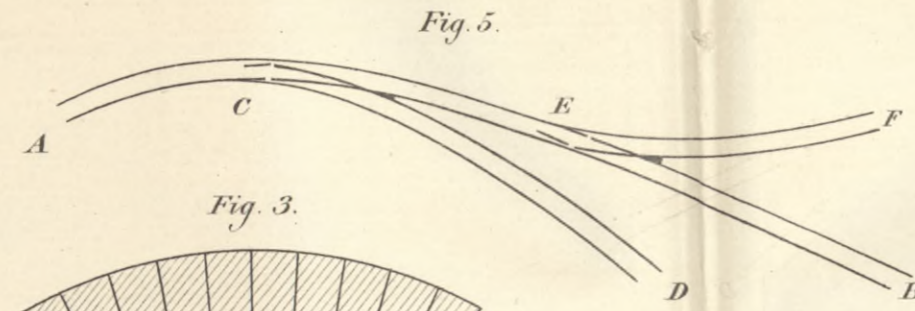
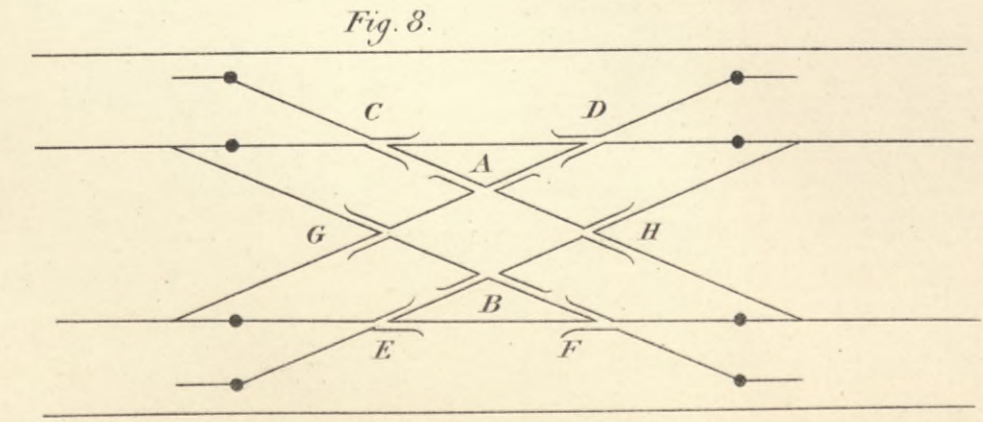
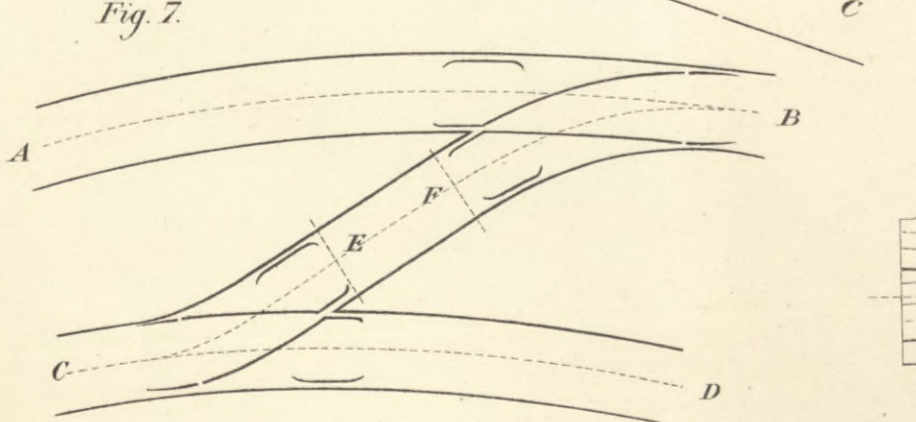
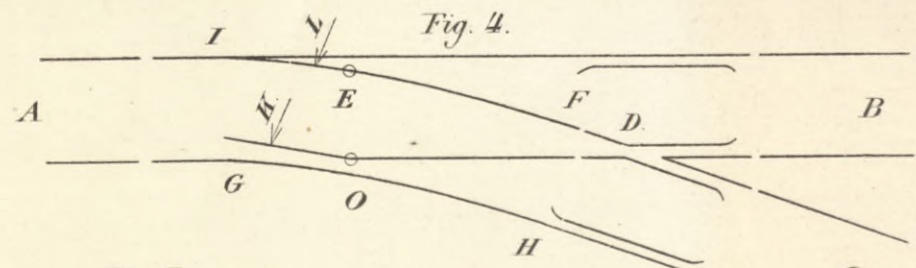
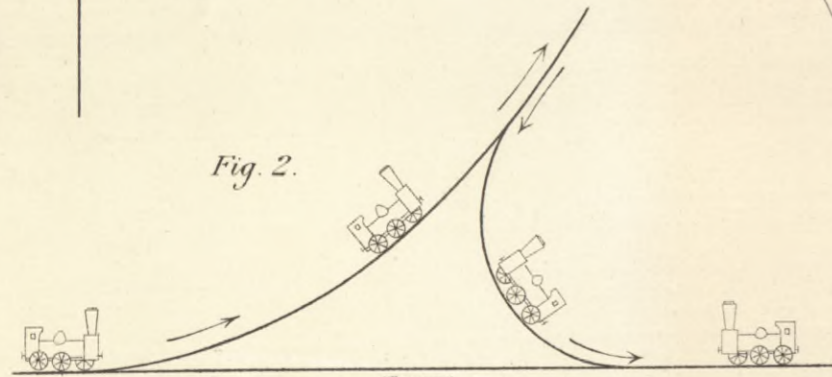
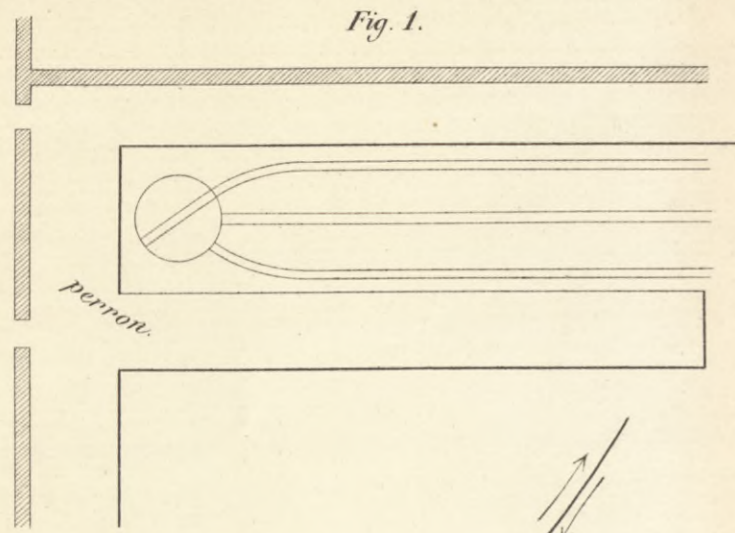
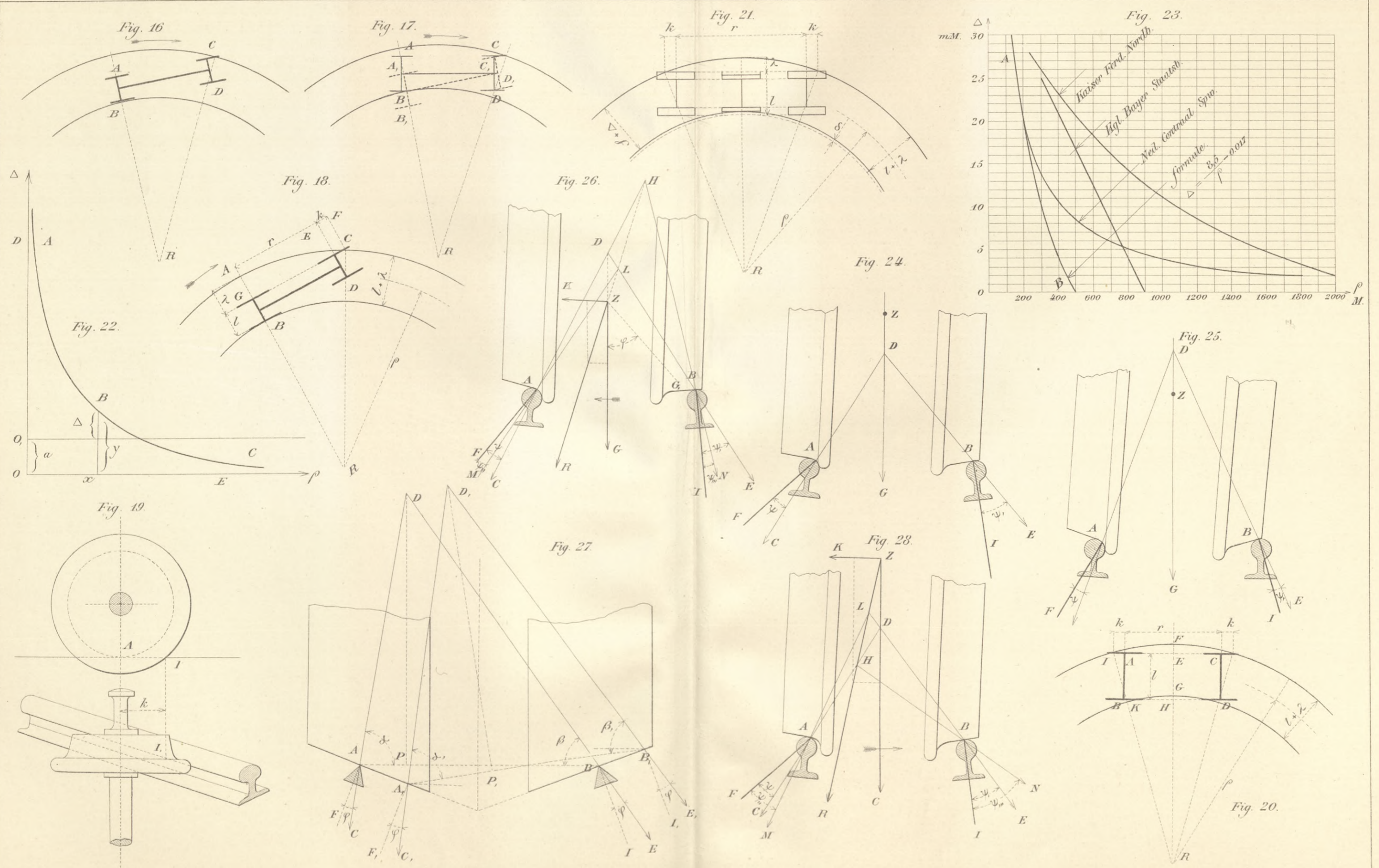


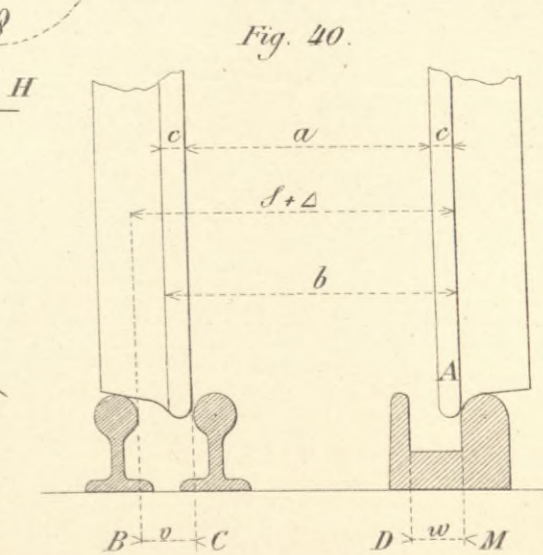
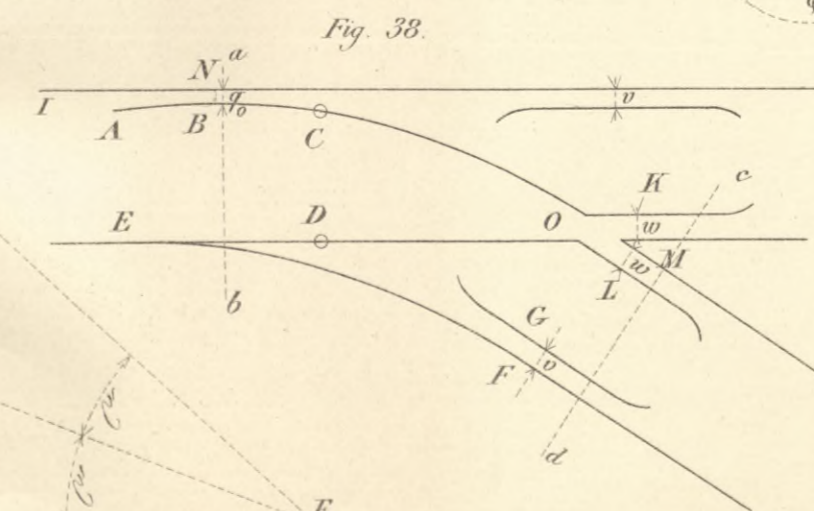
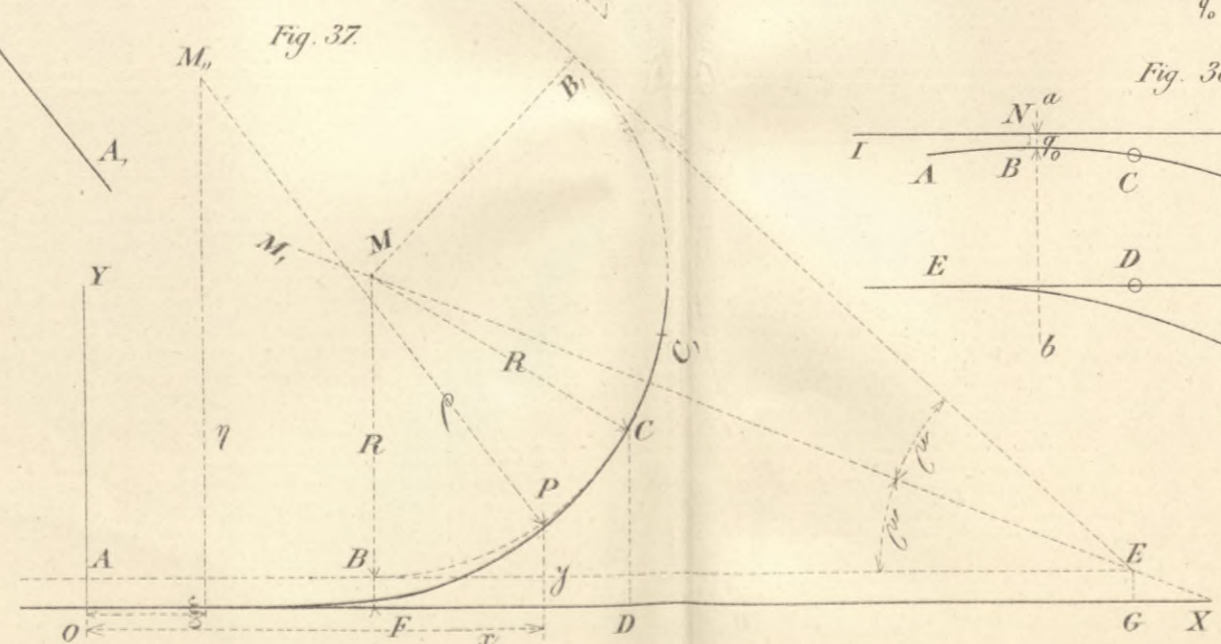
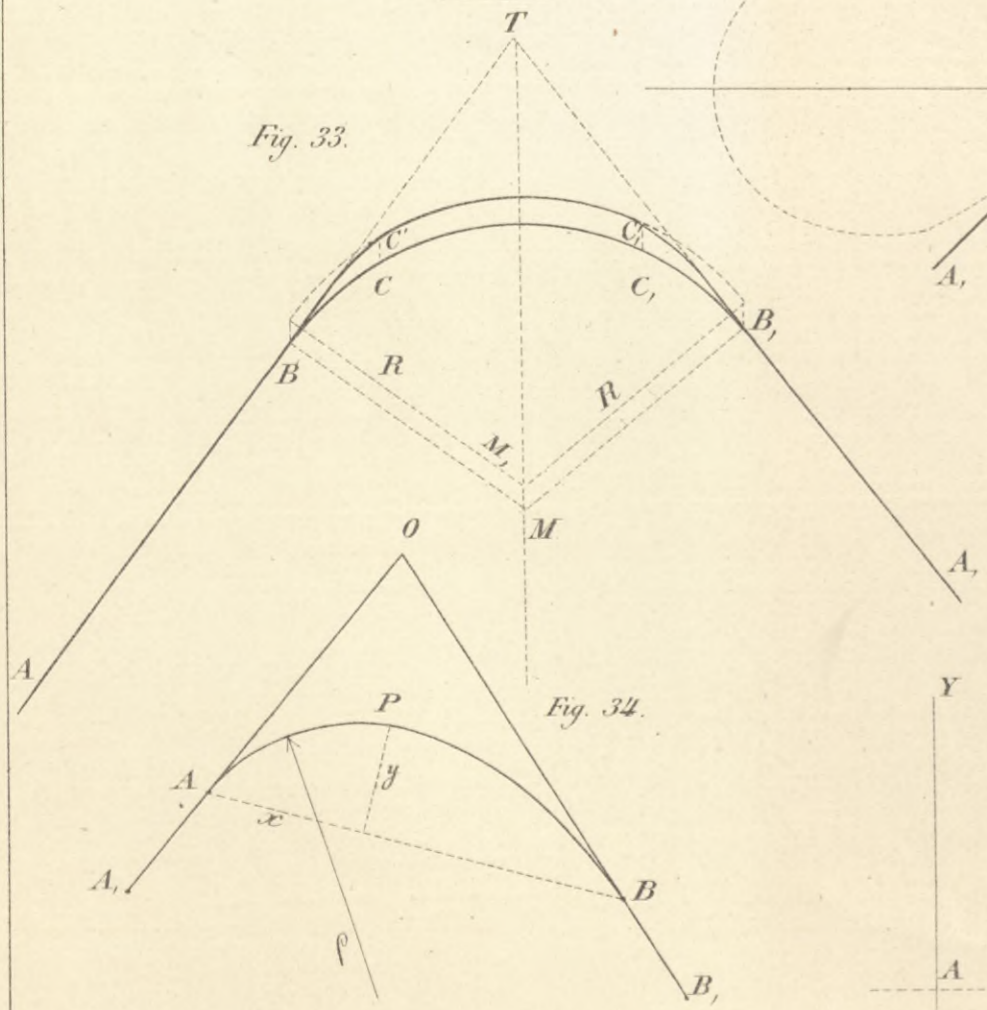
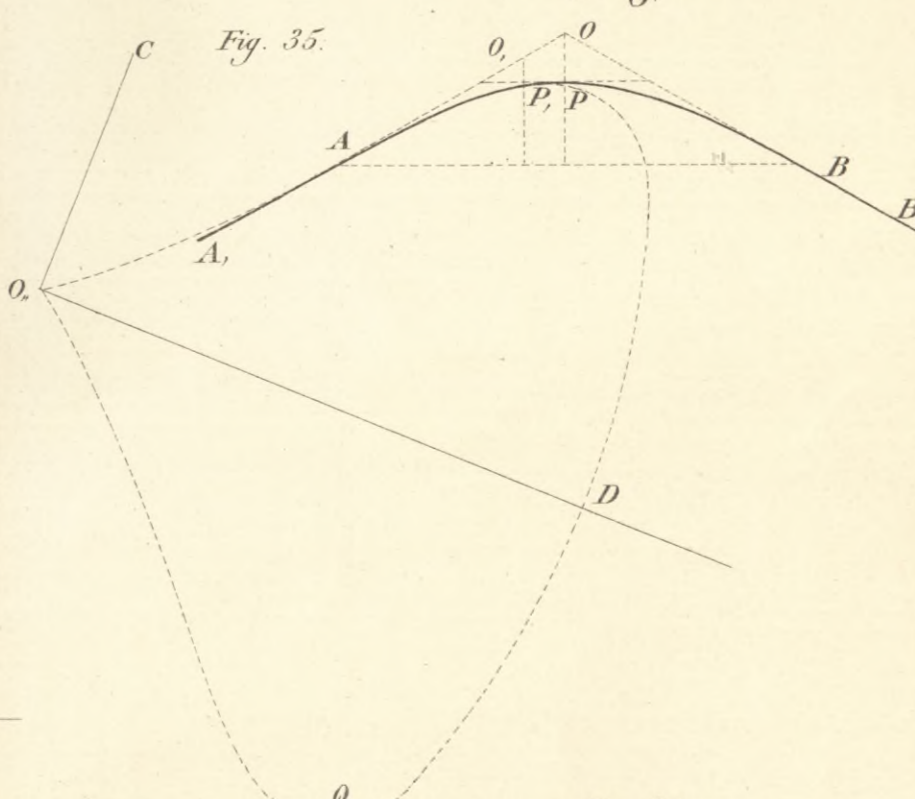
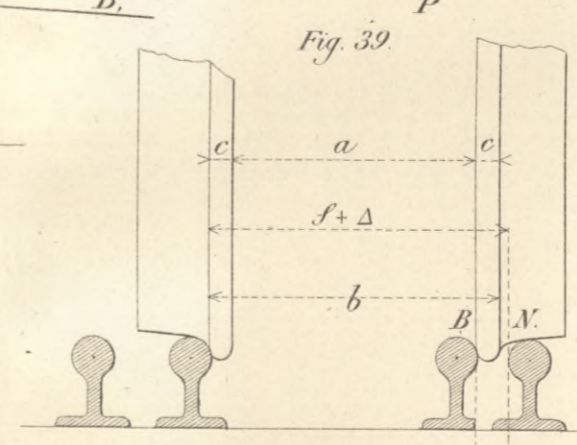
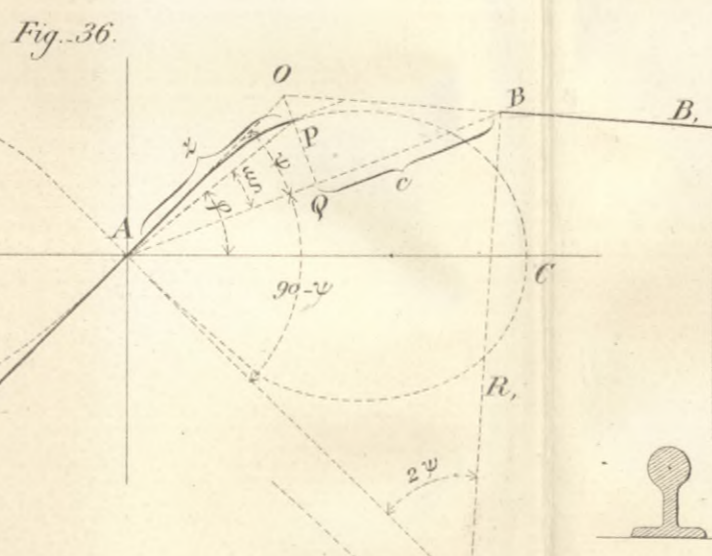
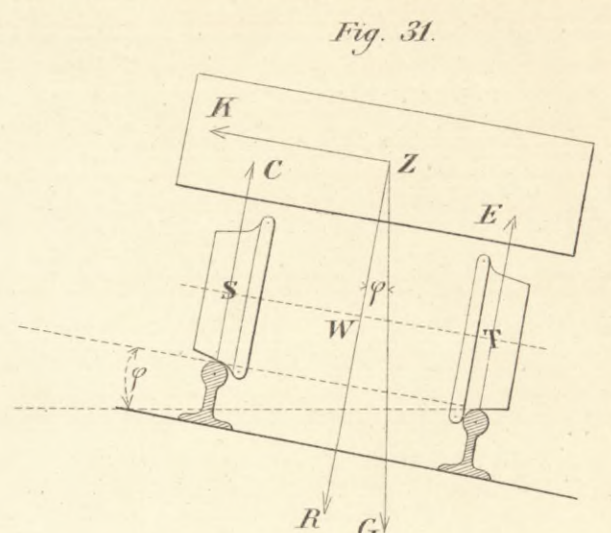
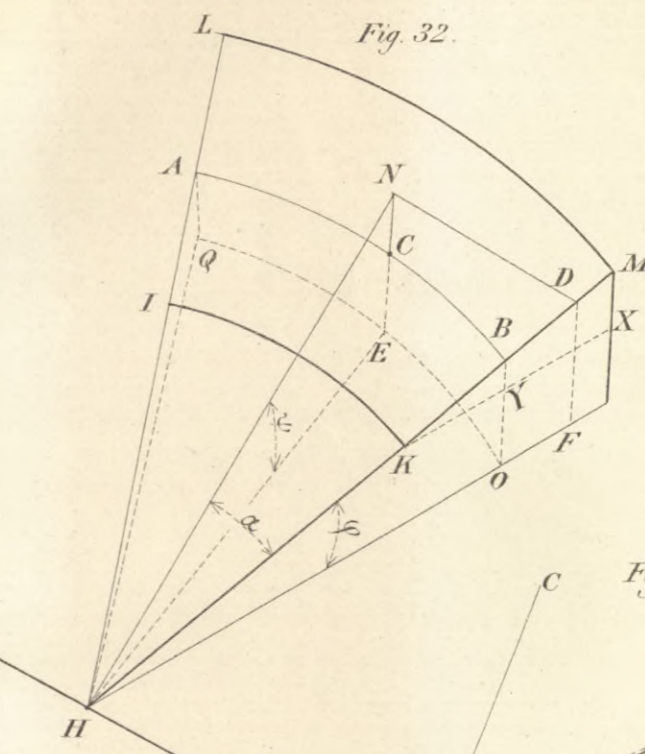
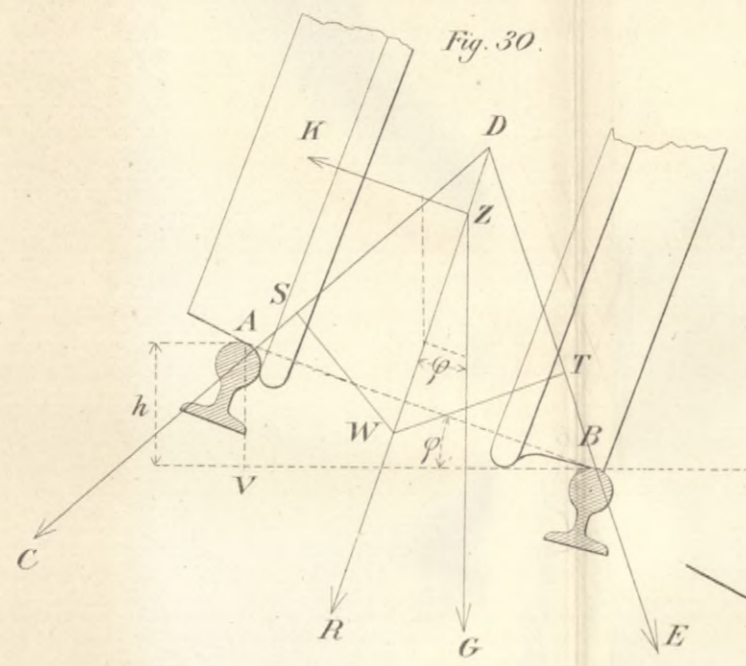
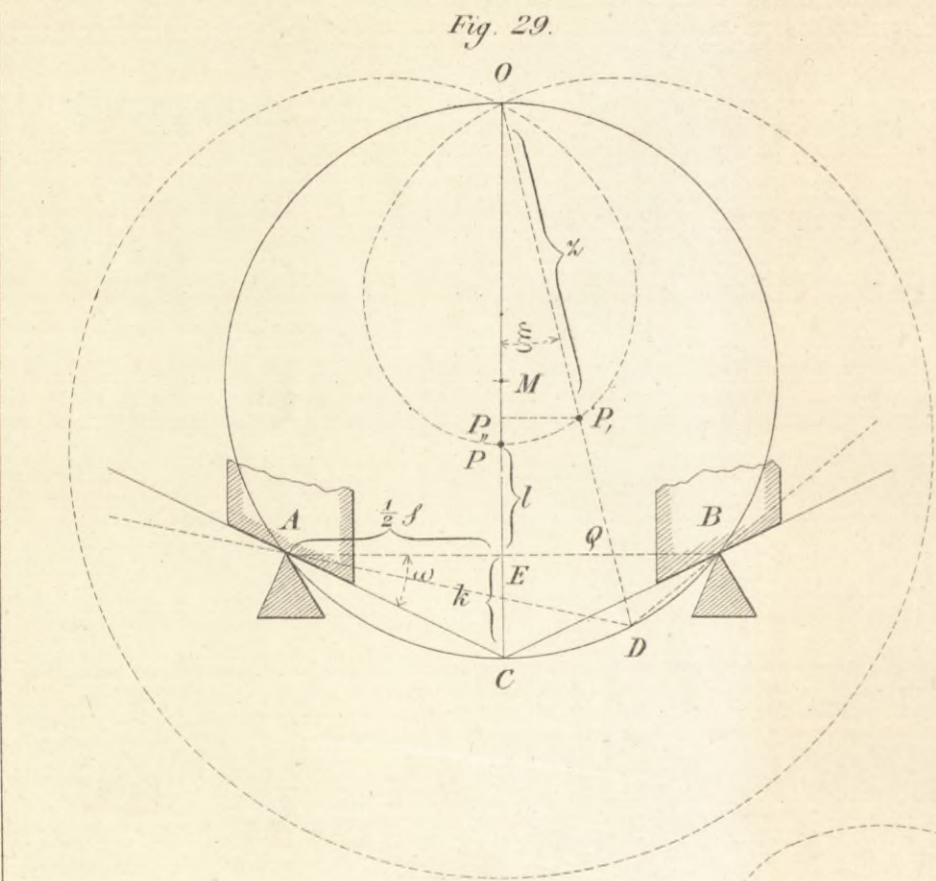
Fig. 51.

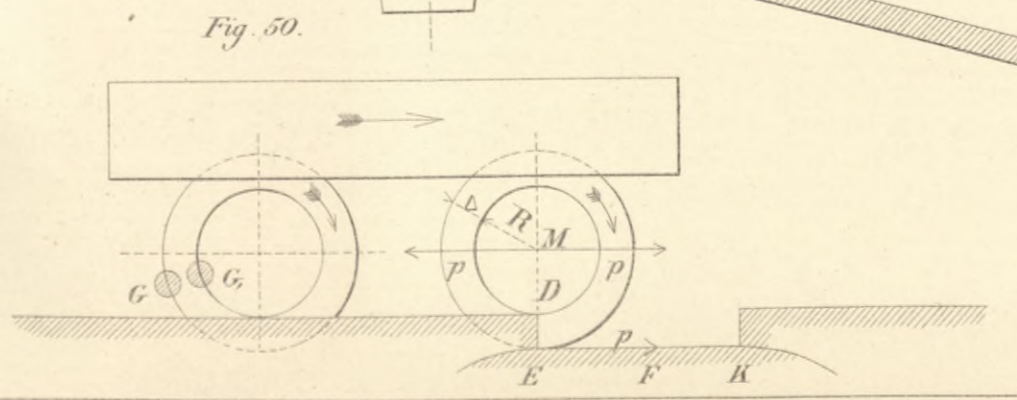
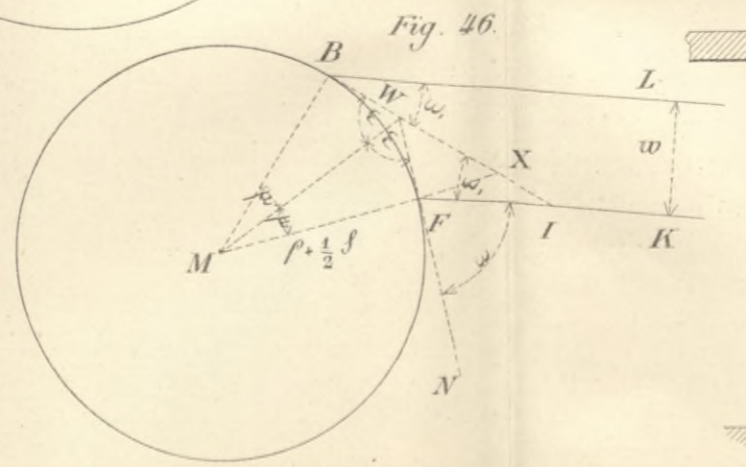
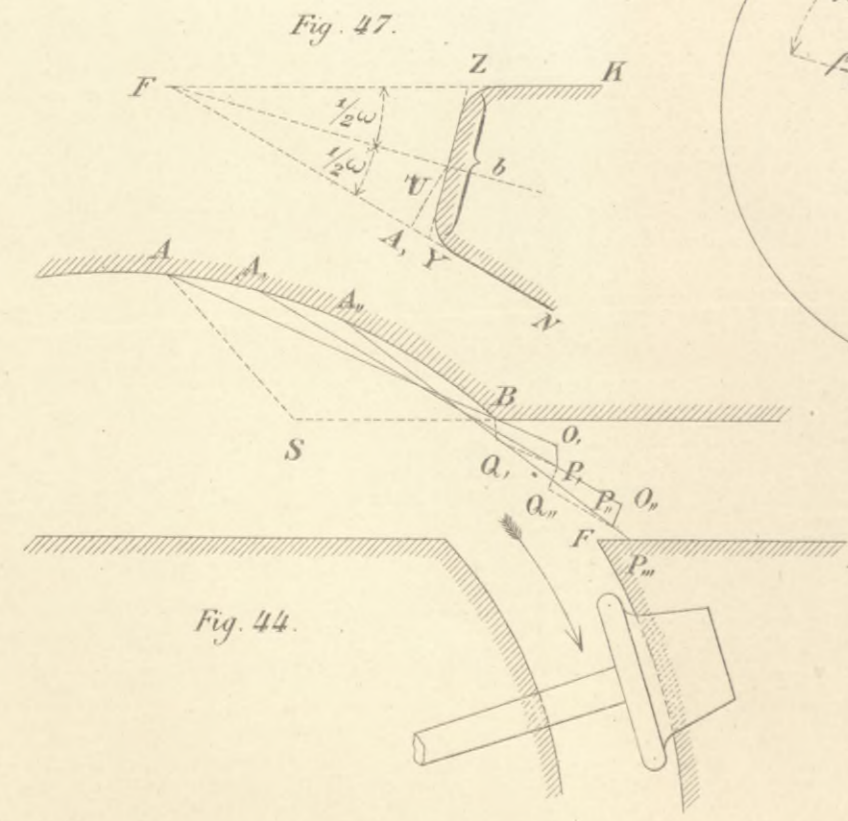
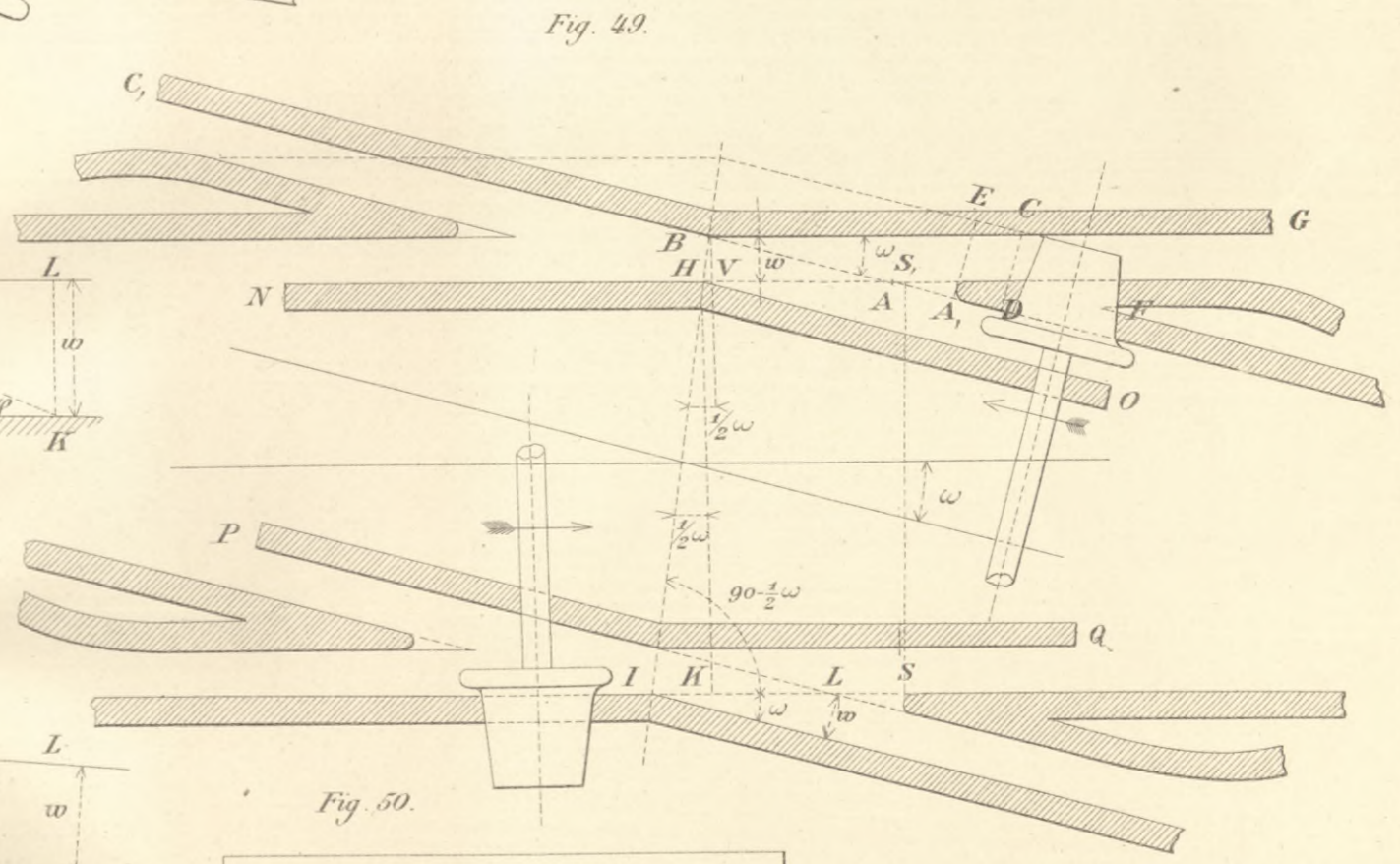
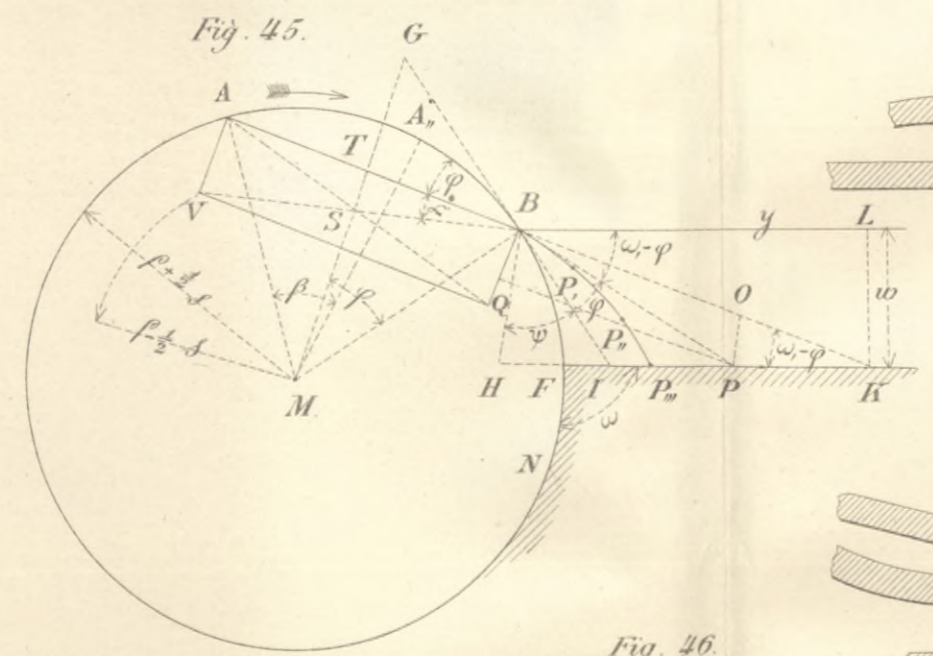
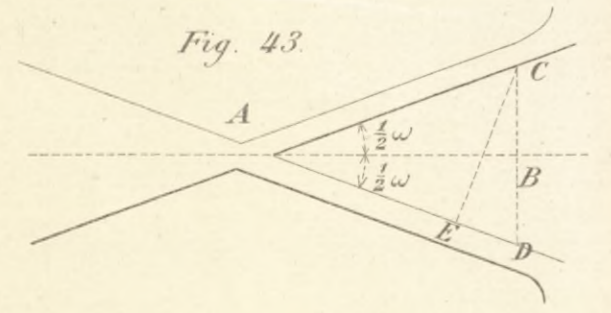
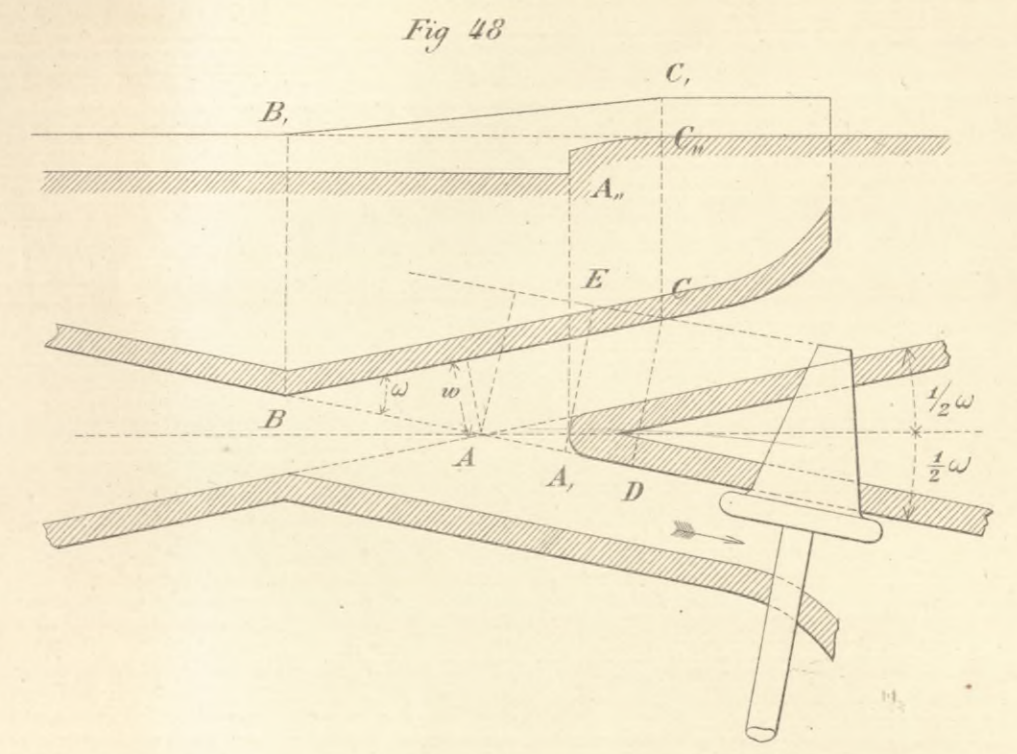
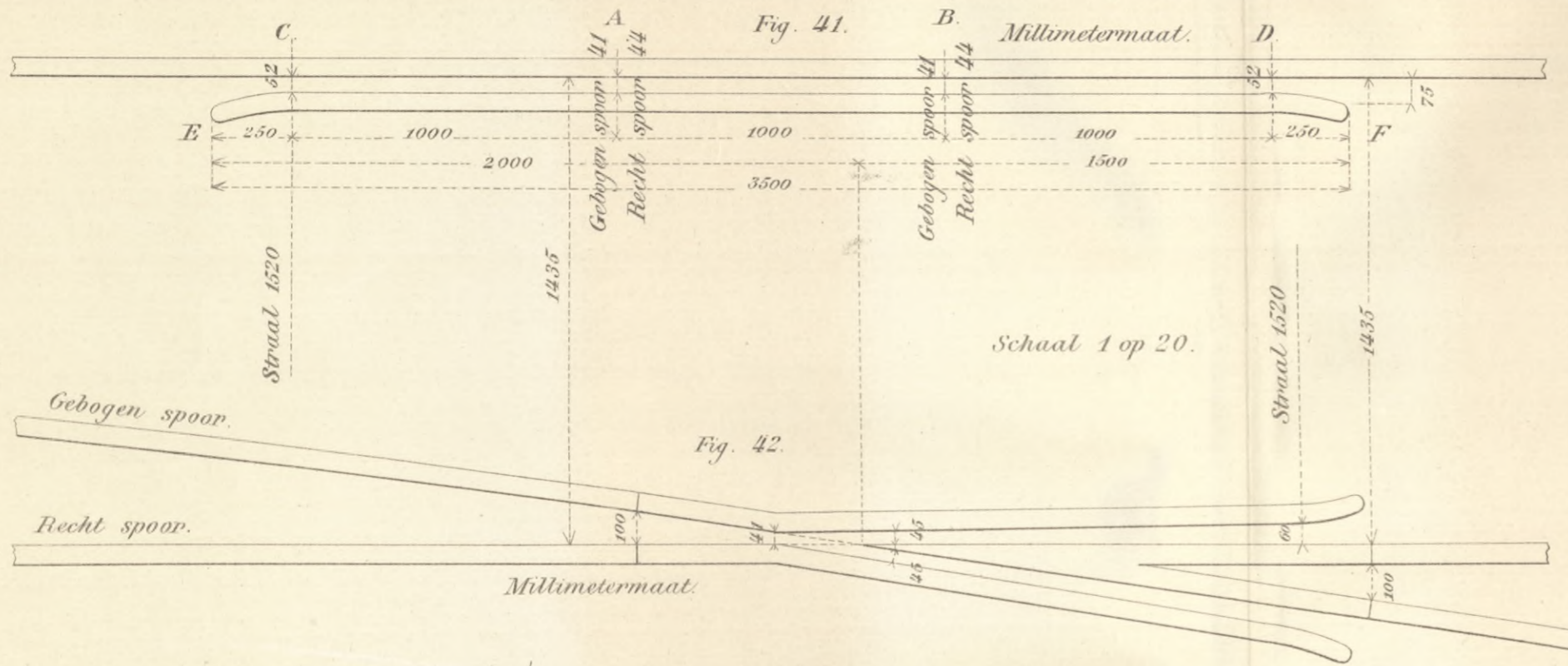












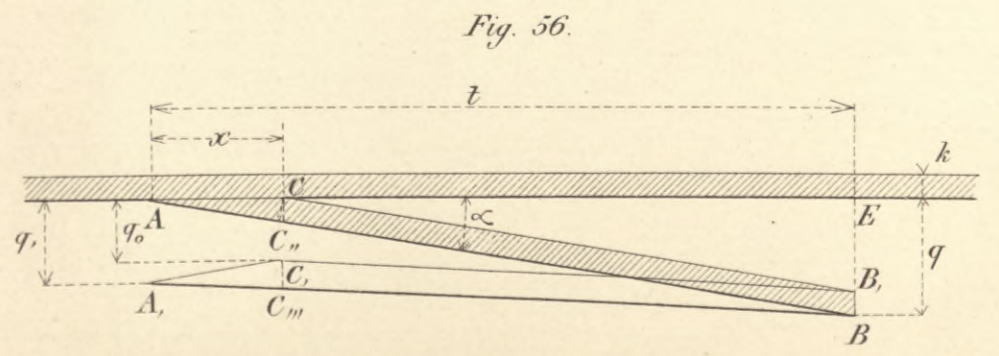
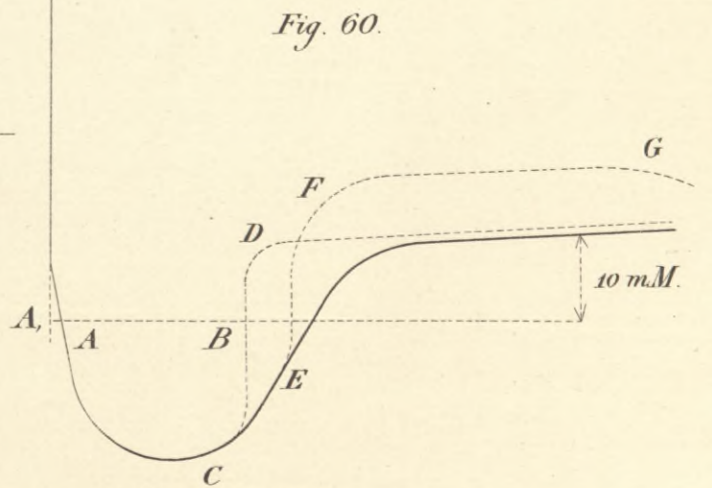
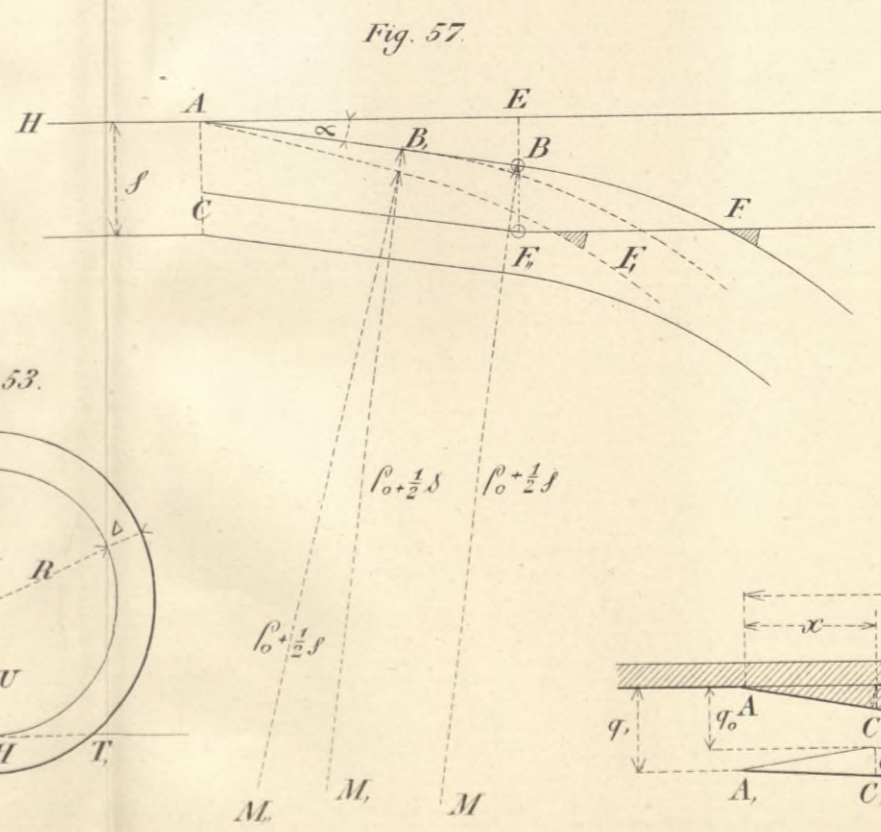
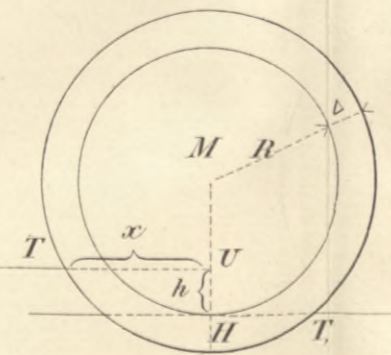
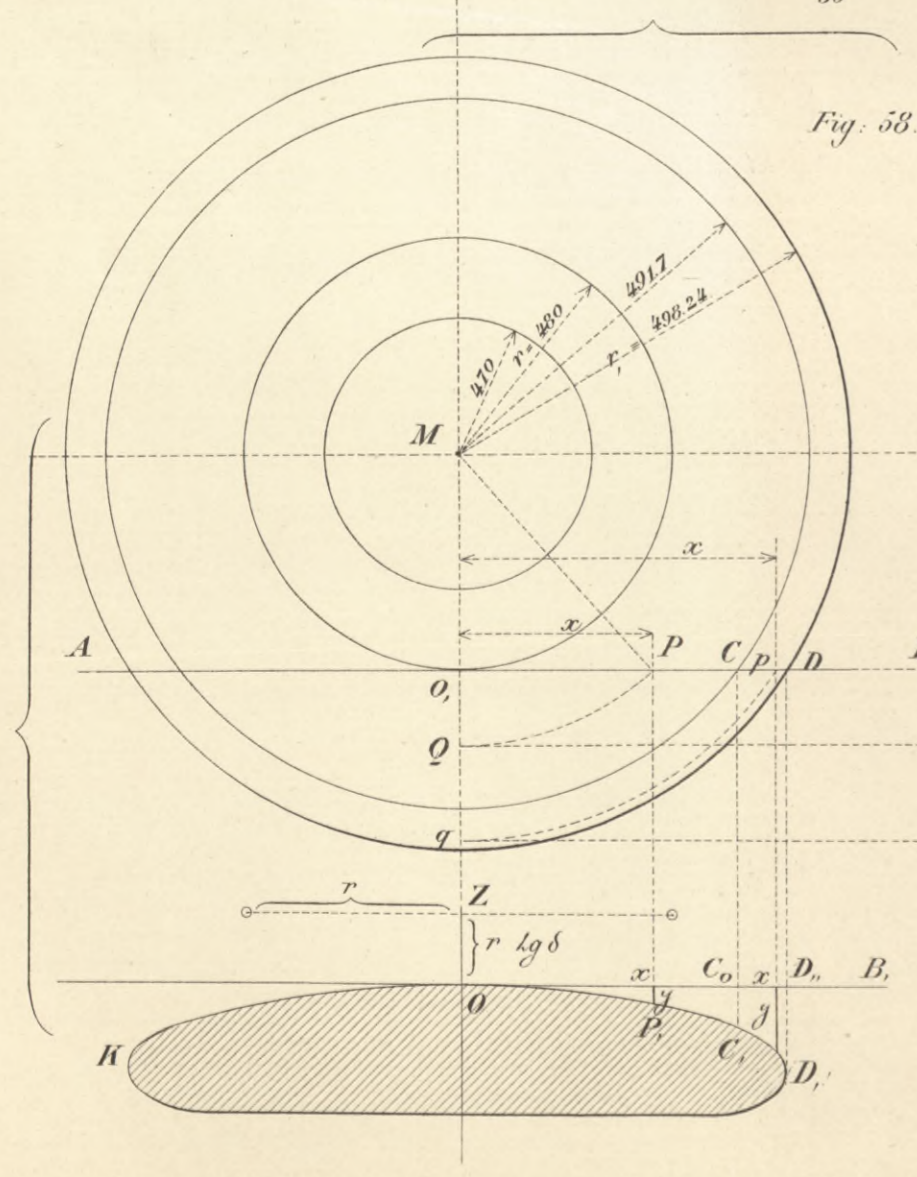
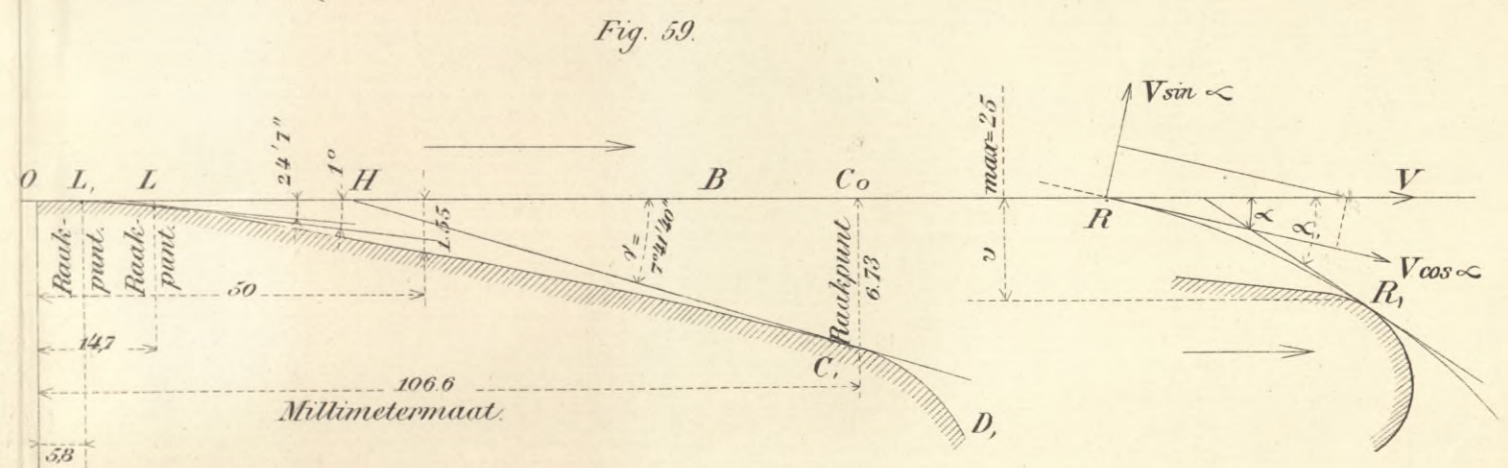
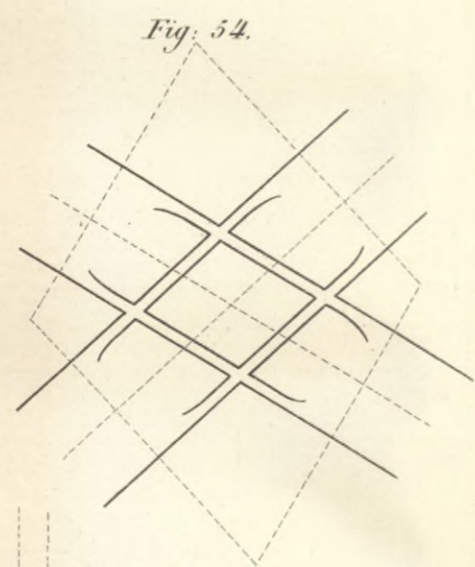
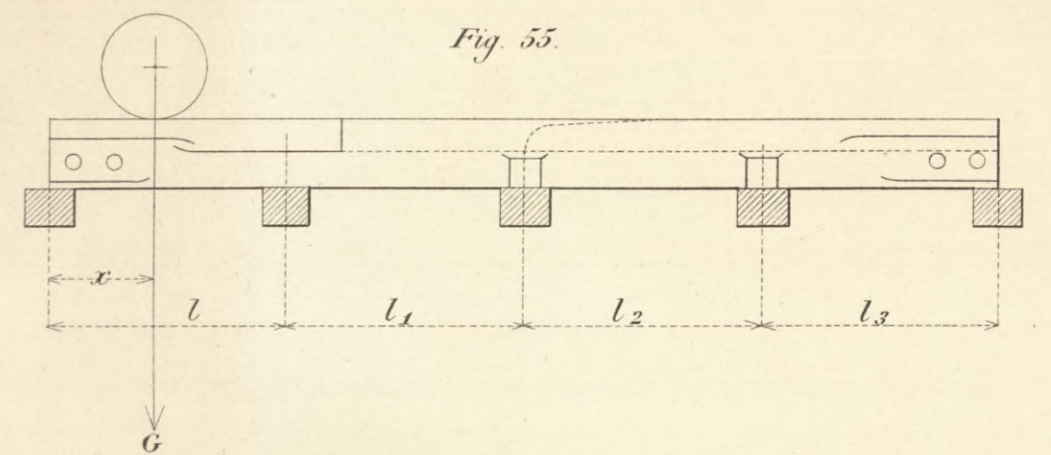
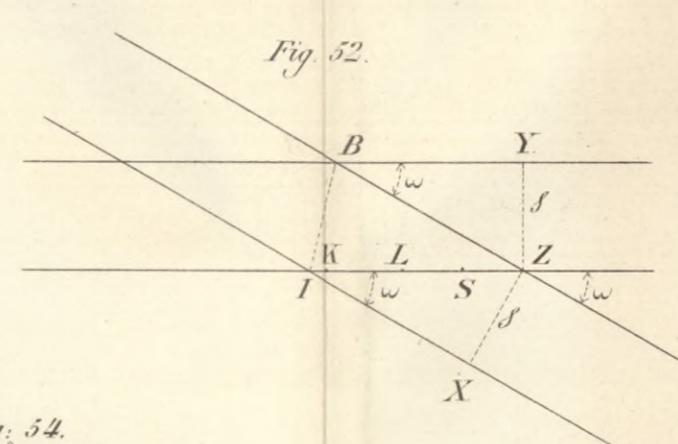
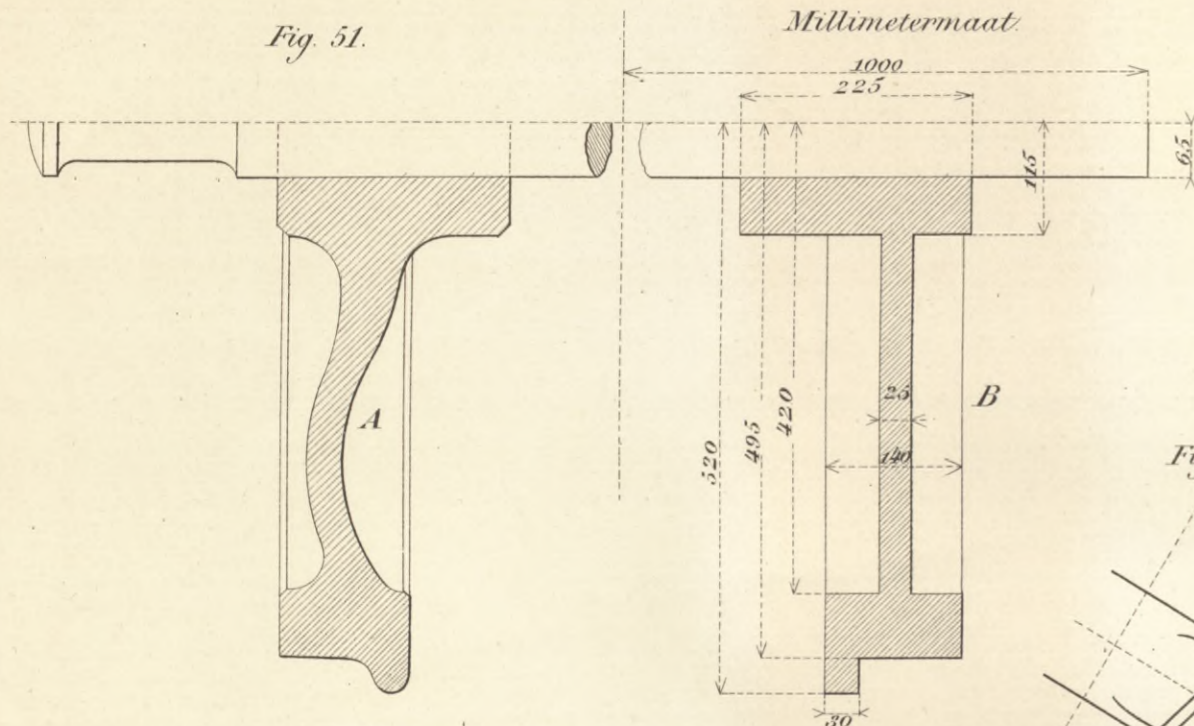


Fig. 61.

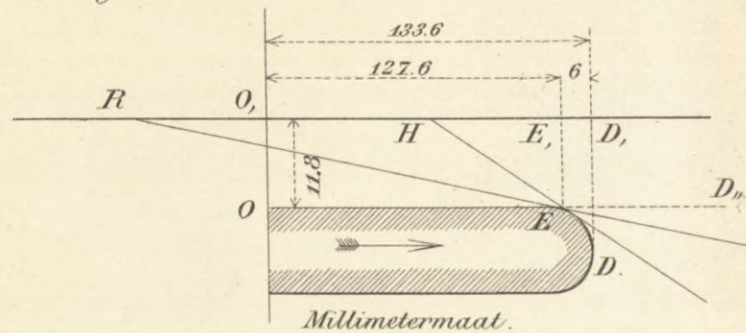


Fig. 62.

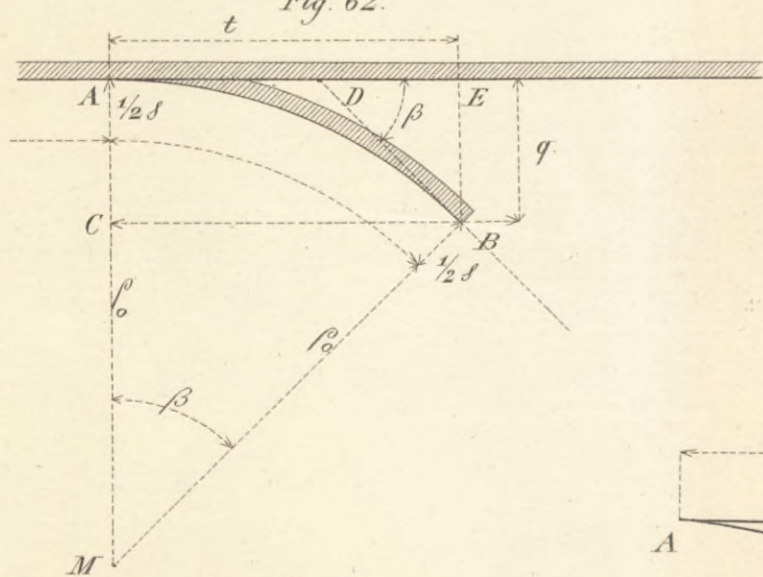


Fig. 63.

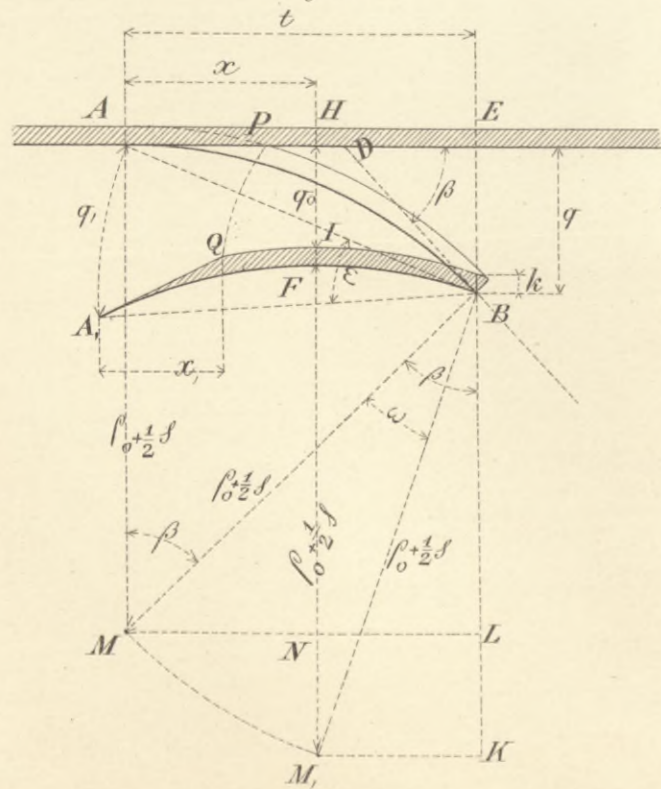


Fig. 69.

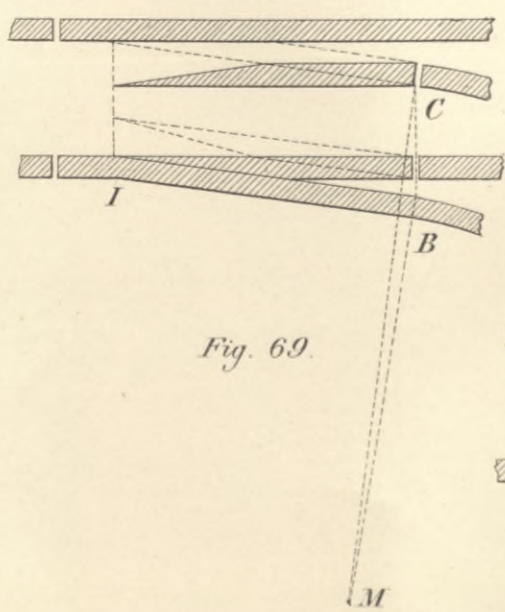


Fig. 71.

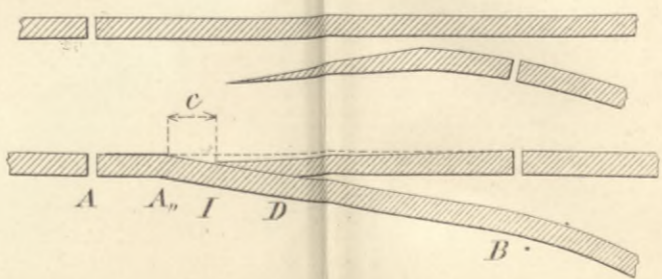


Fig. 65.

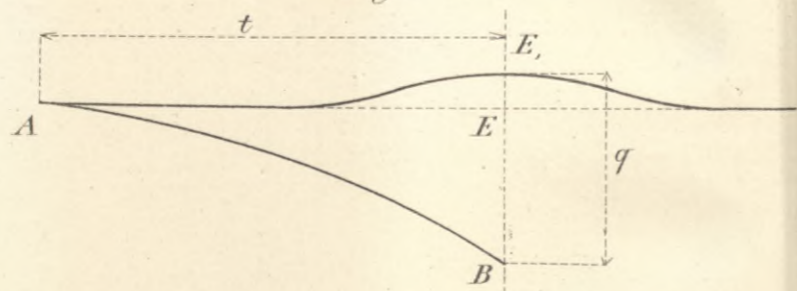


Fig. 64.

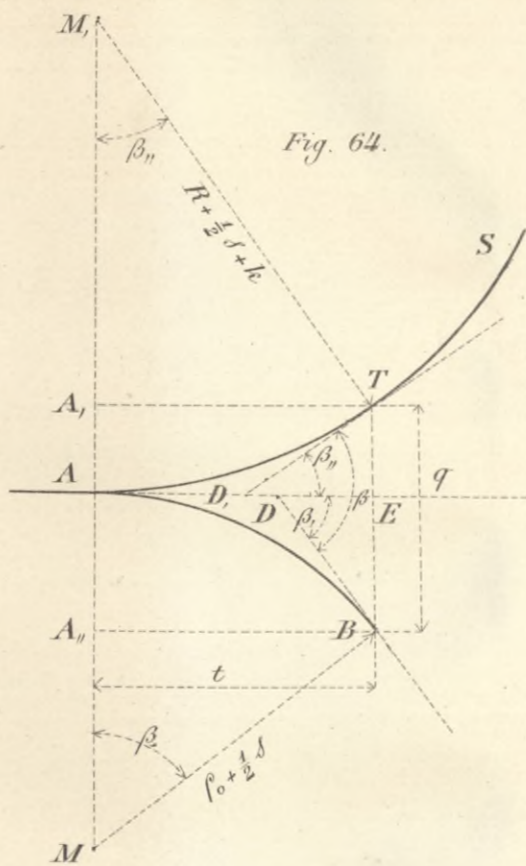


Fig. 67.

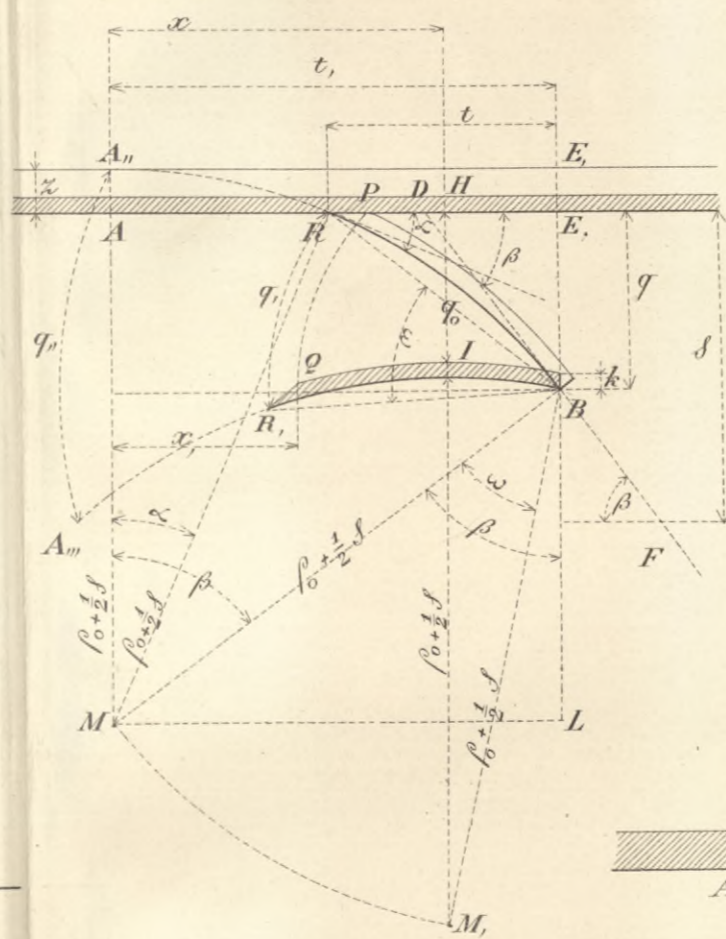


Fig. 70.

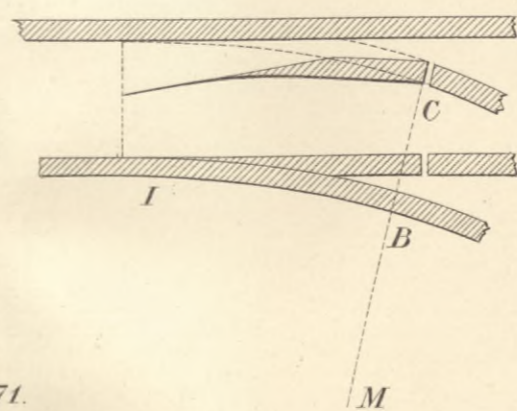


Fig. 66.

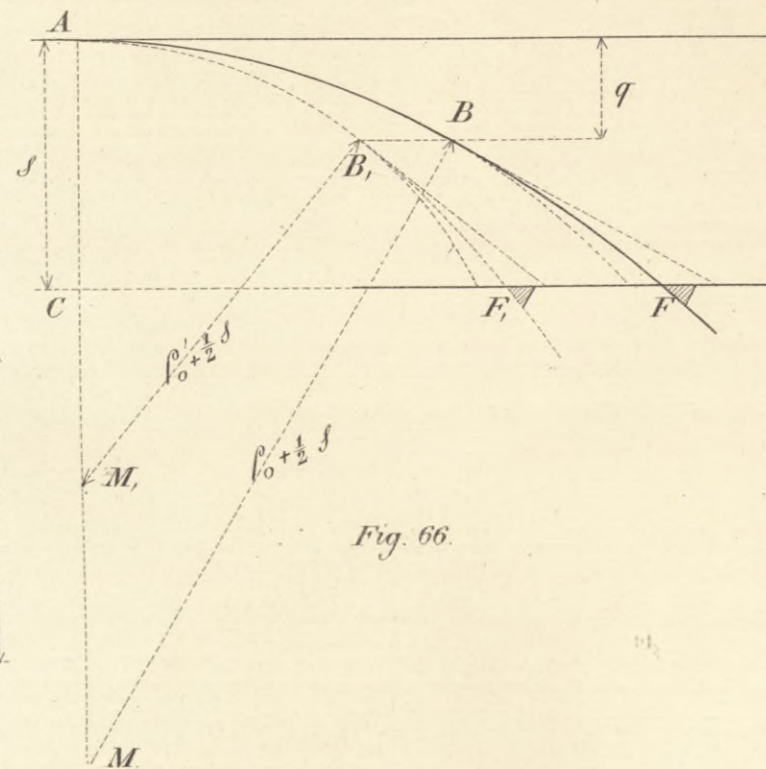
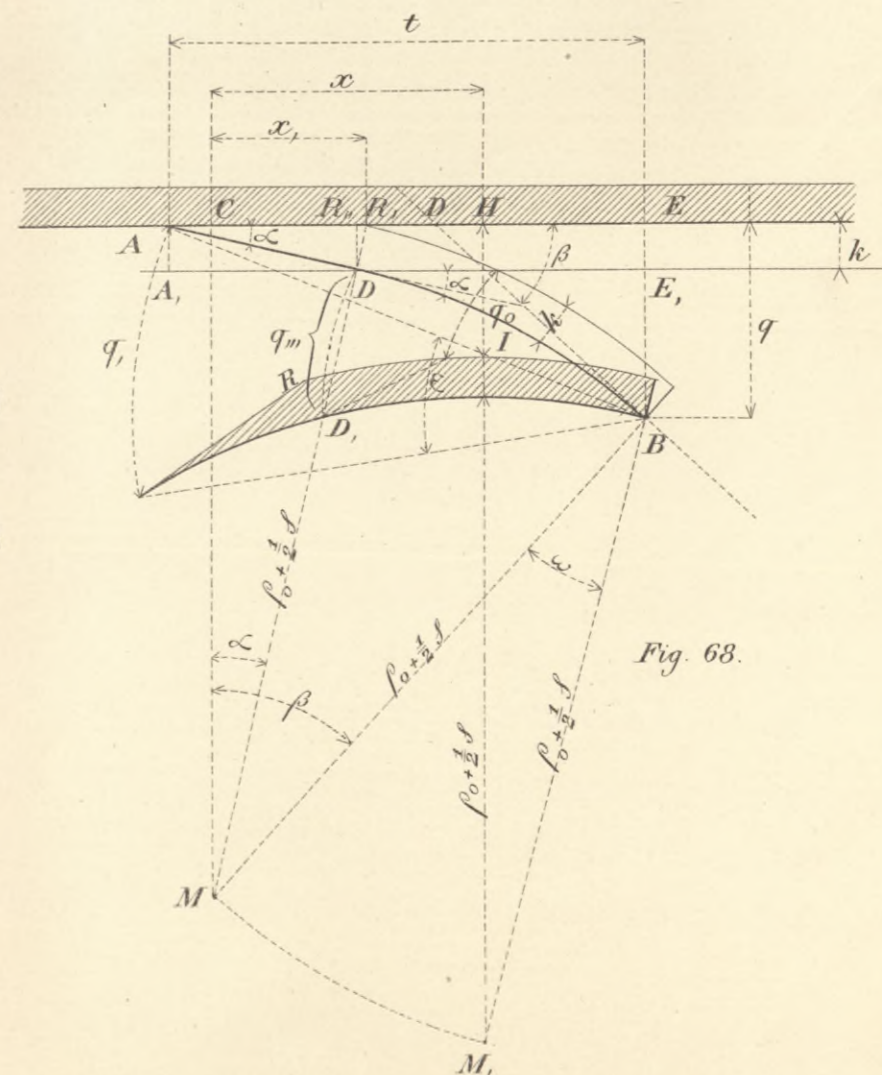
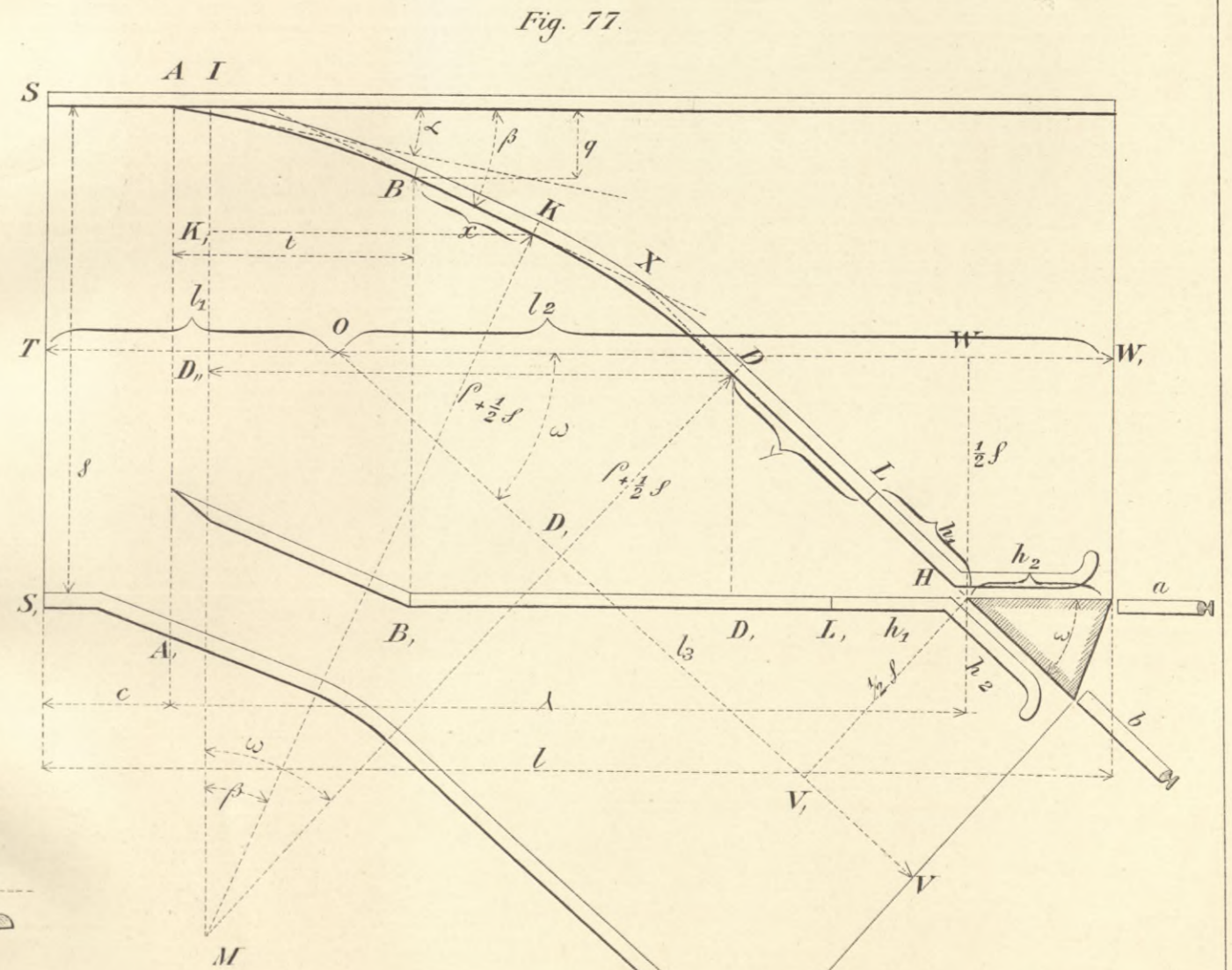
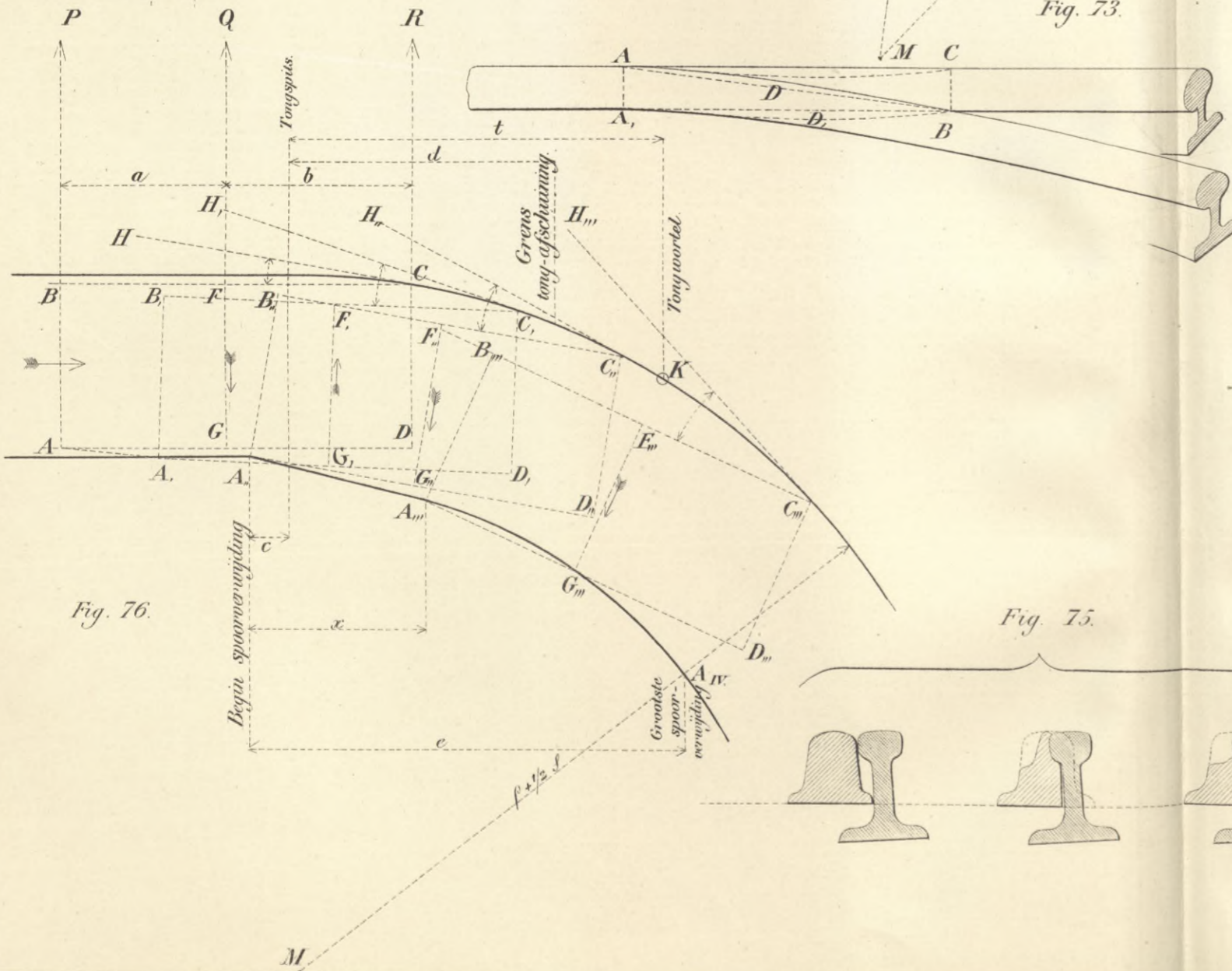
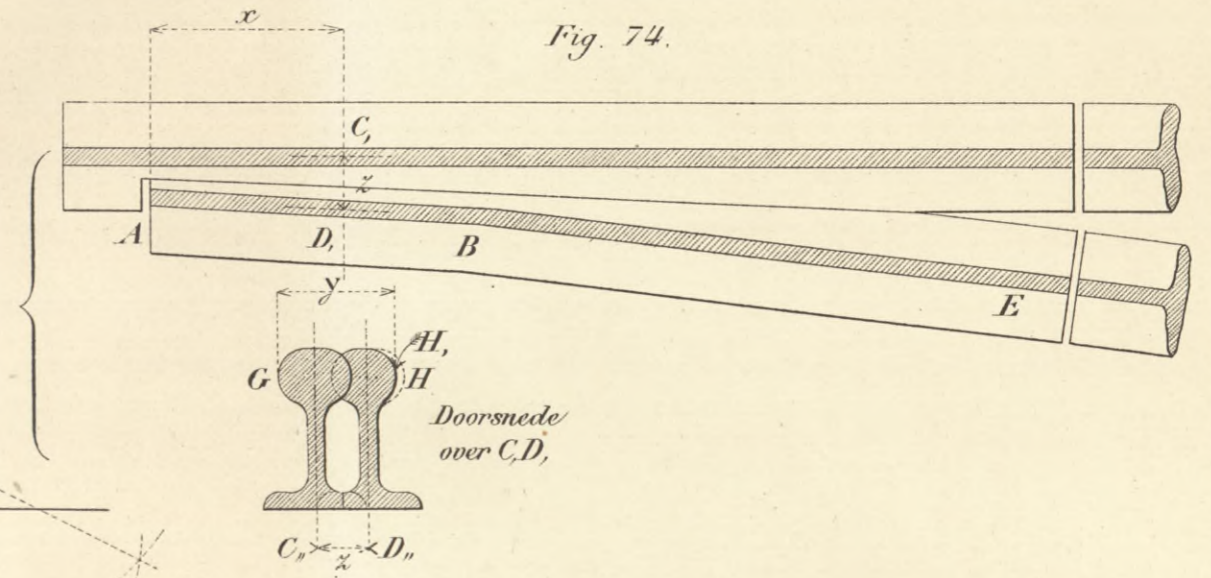
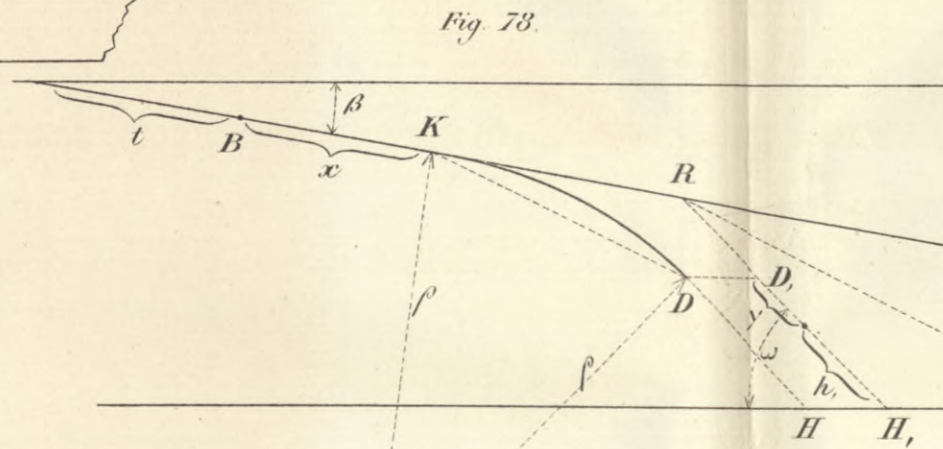
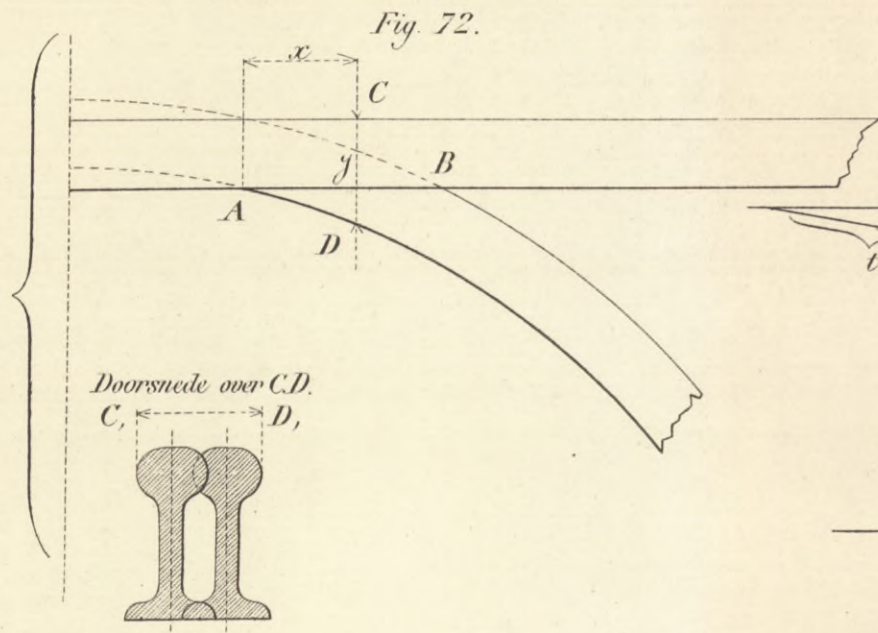
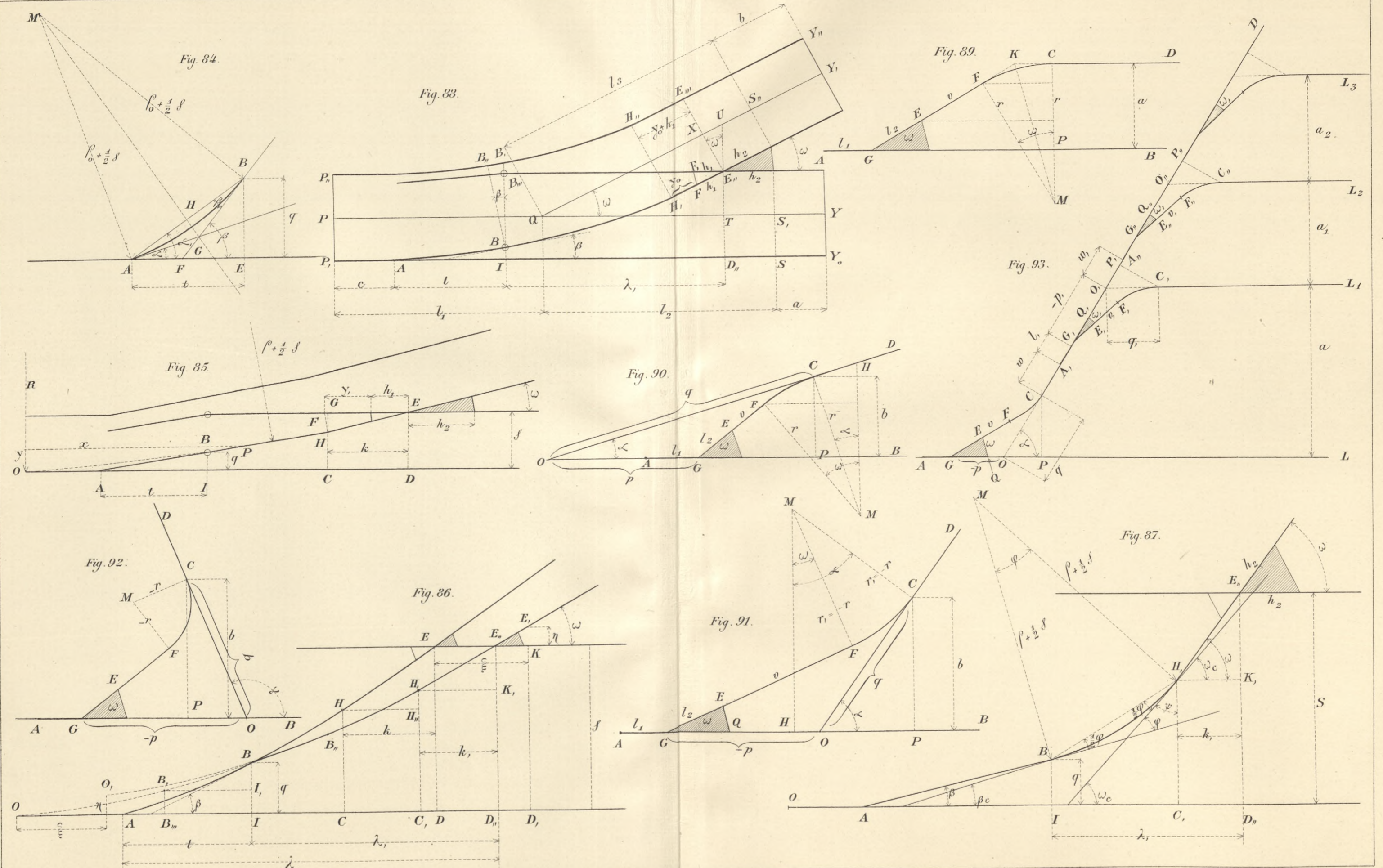


Fig. 68.







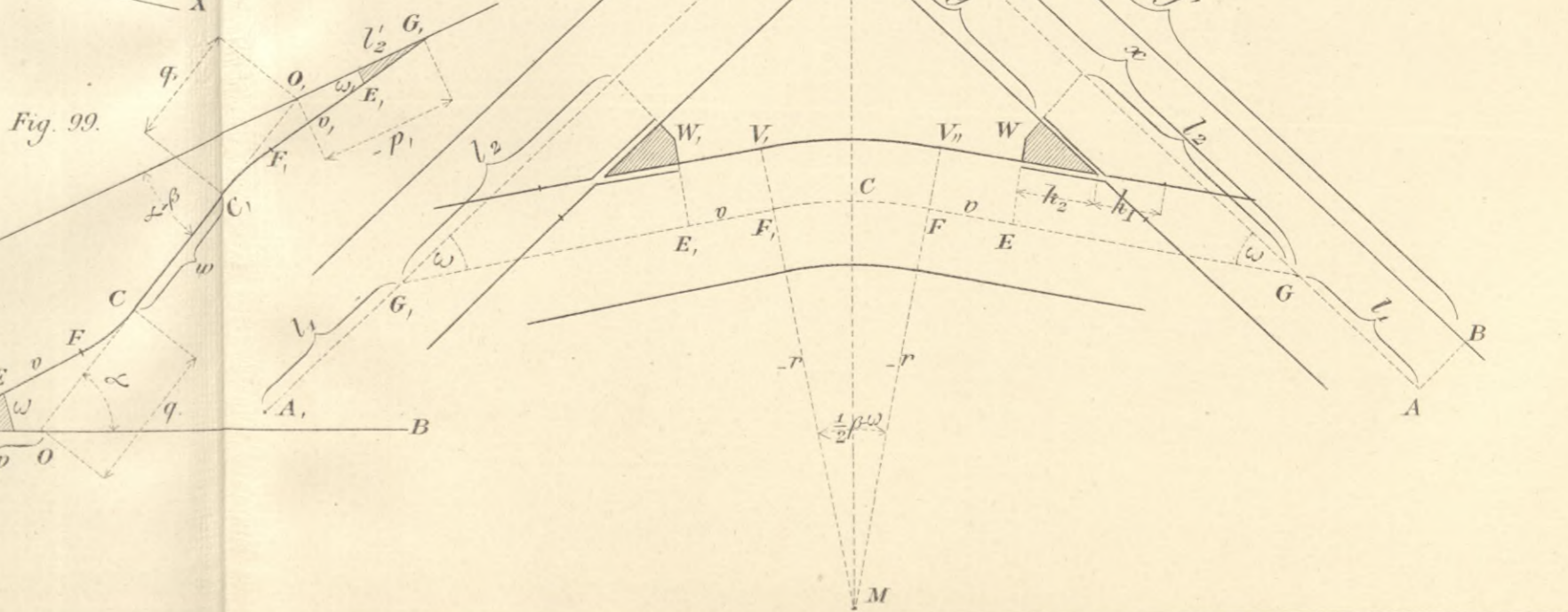
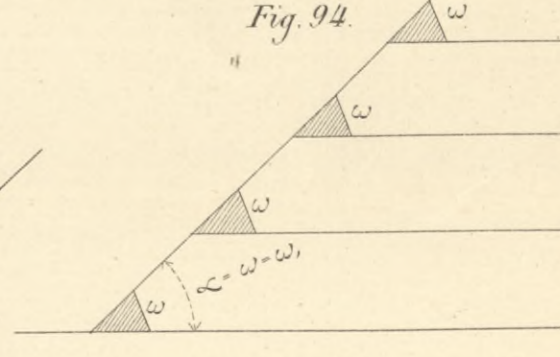
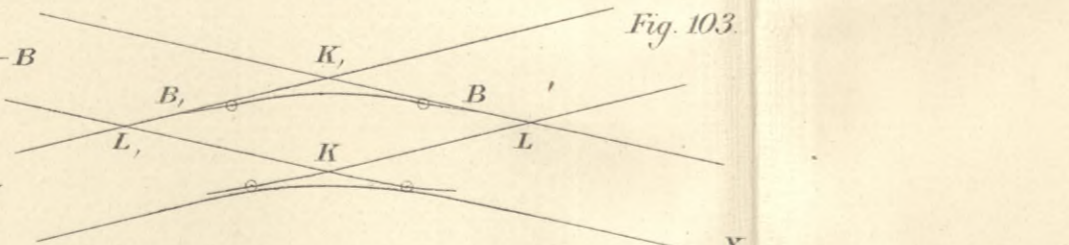
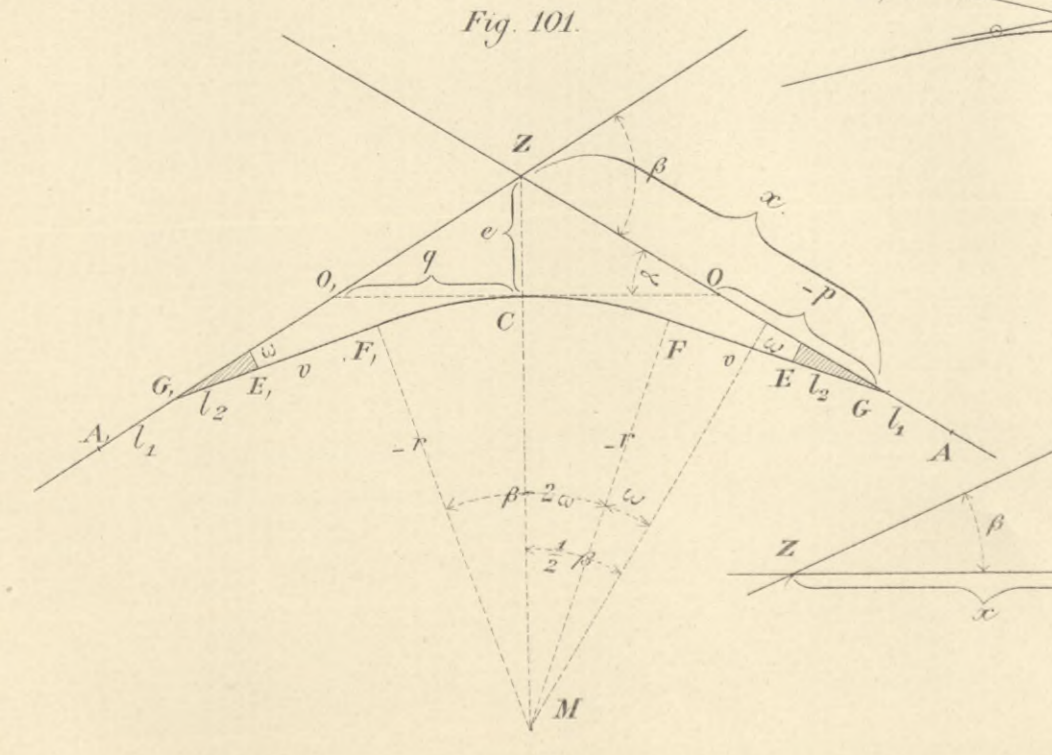
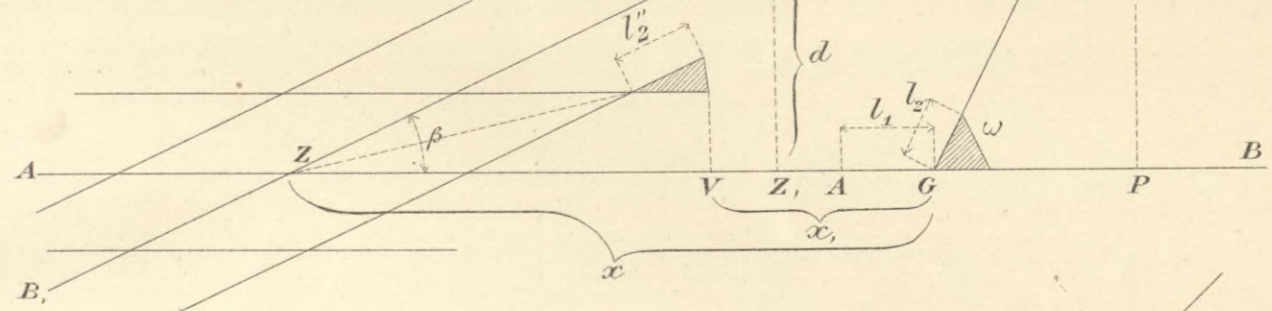
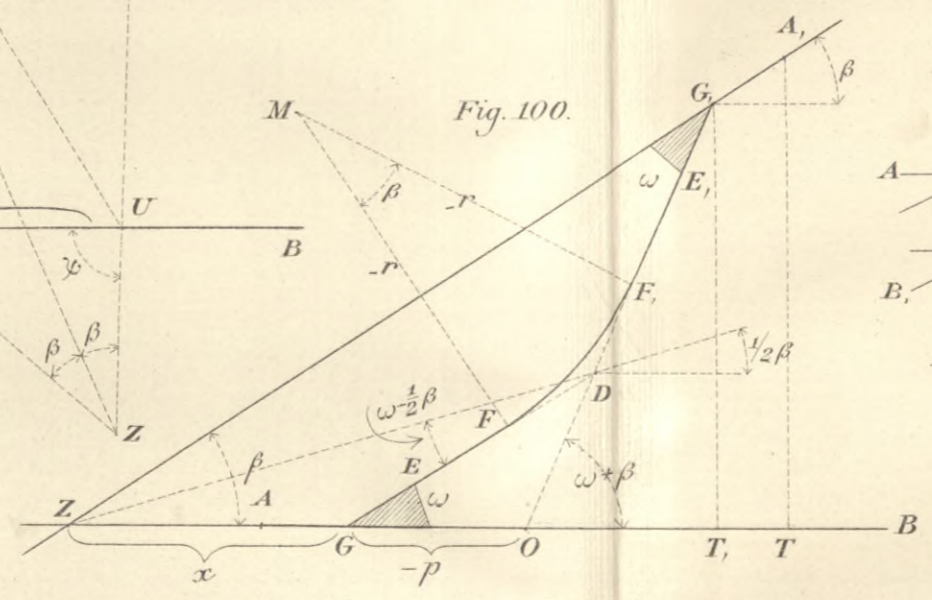
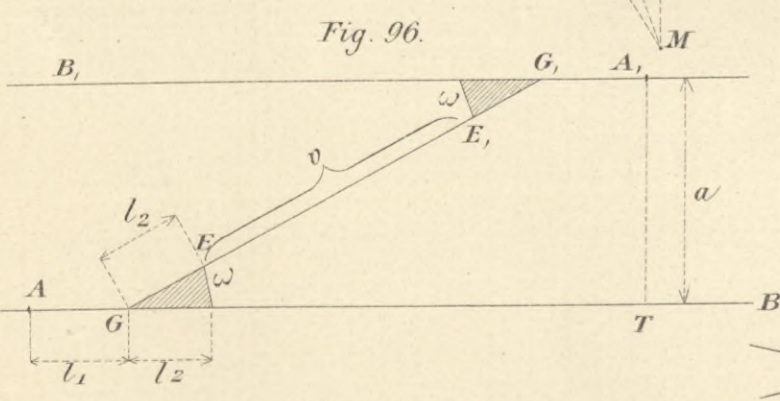
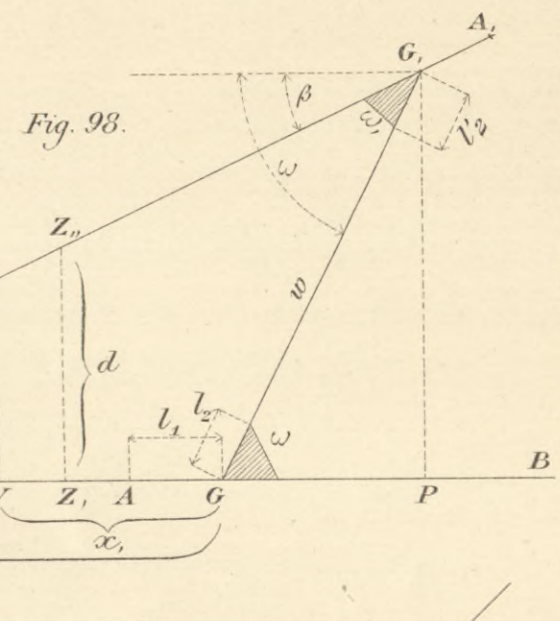
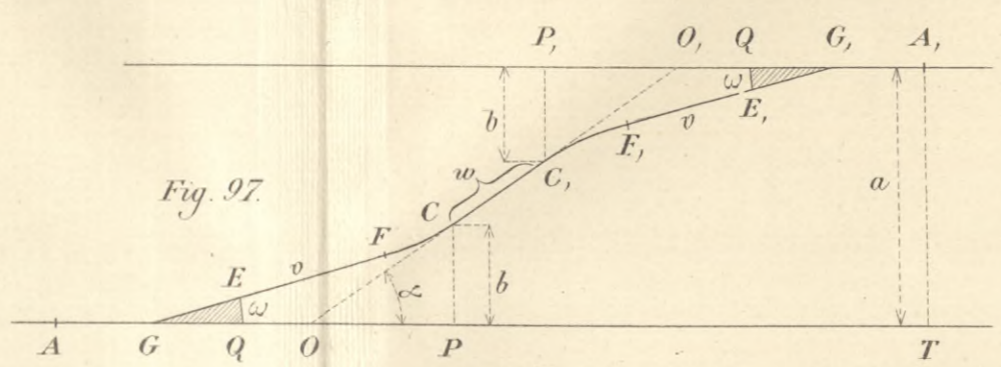
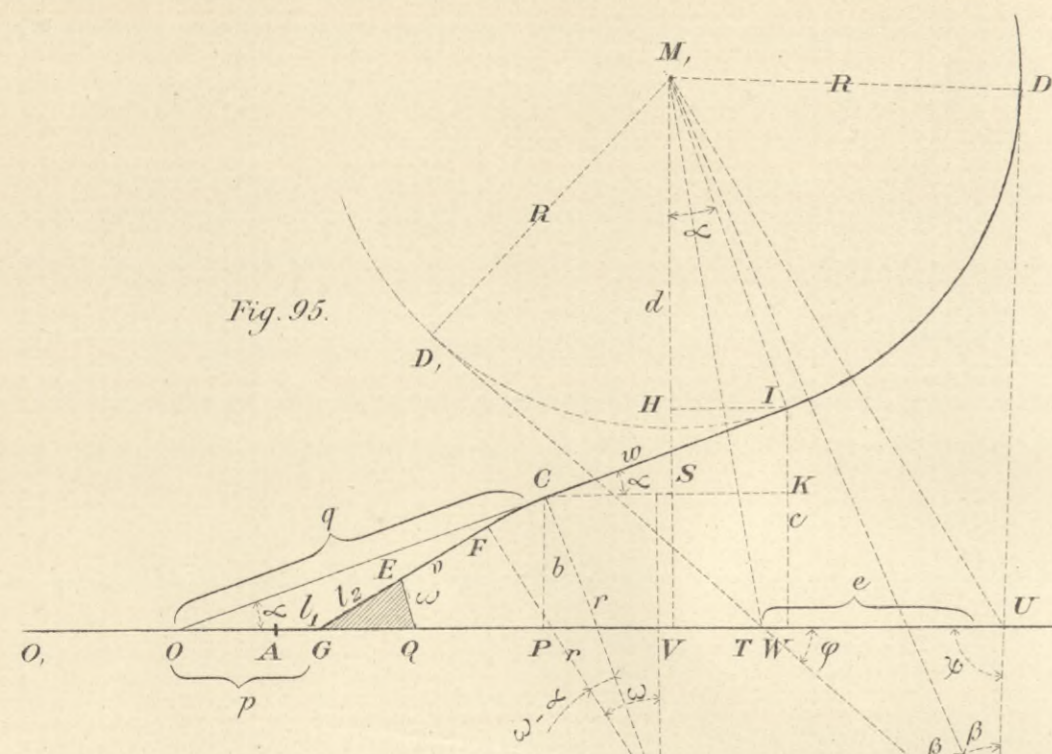


Fig. 113.

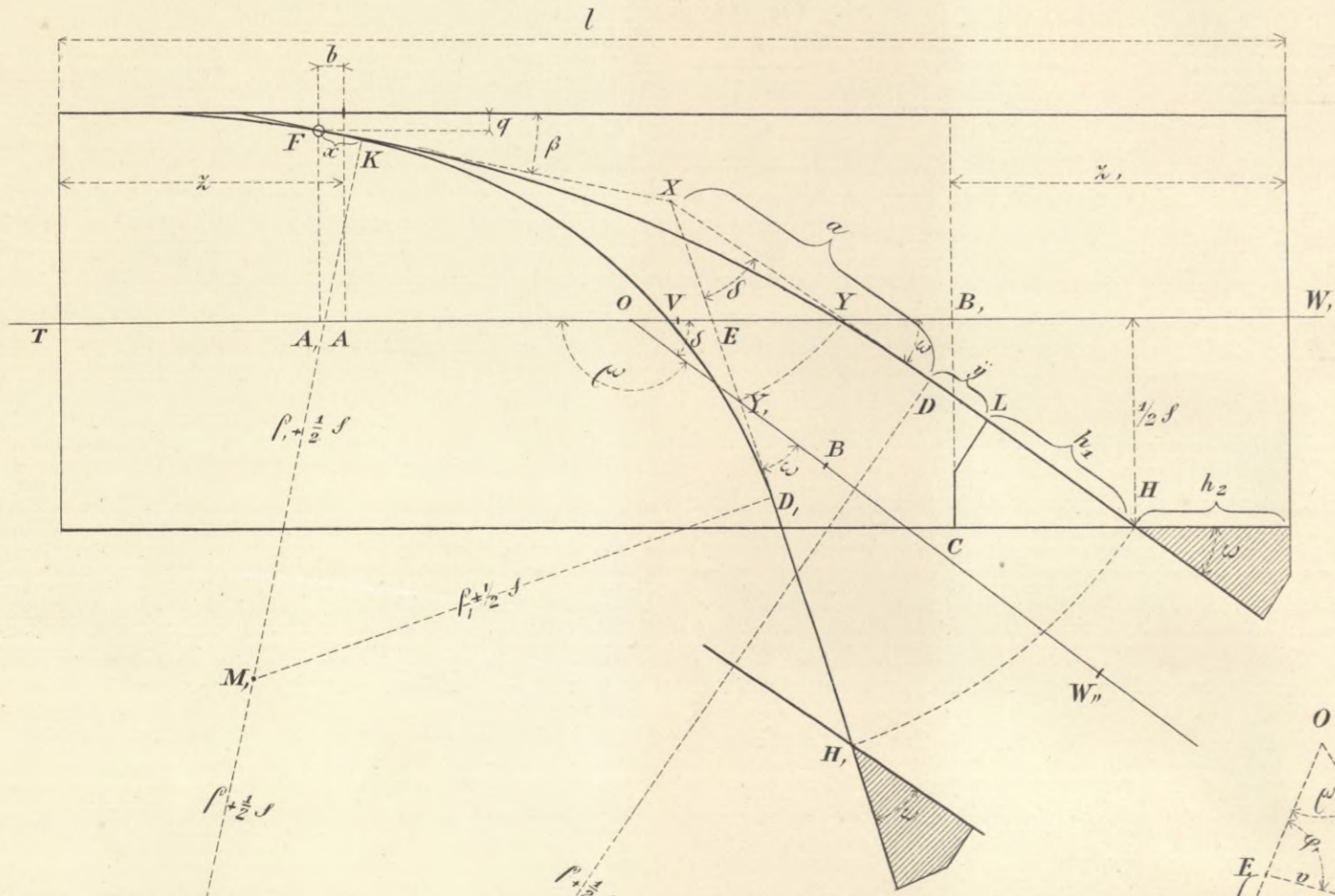


Fig. 113.

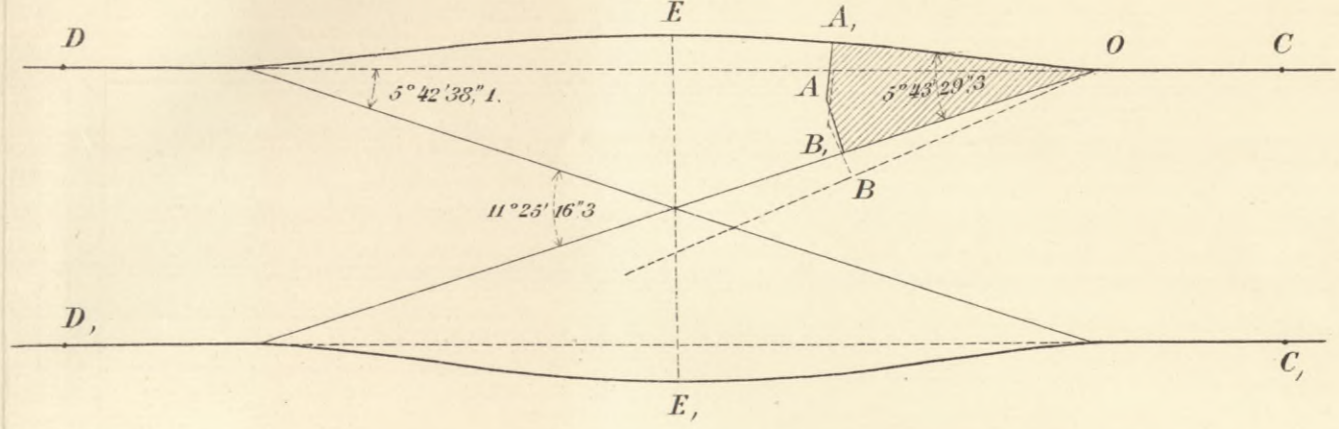


Fig. 119.

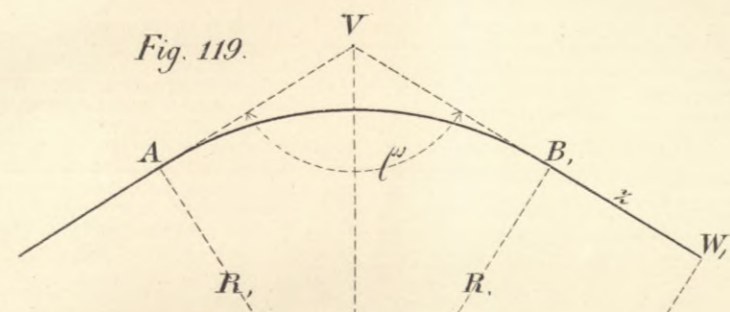


Fig. 116.

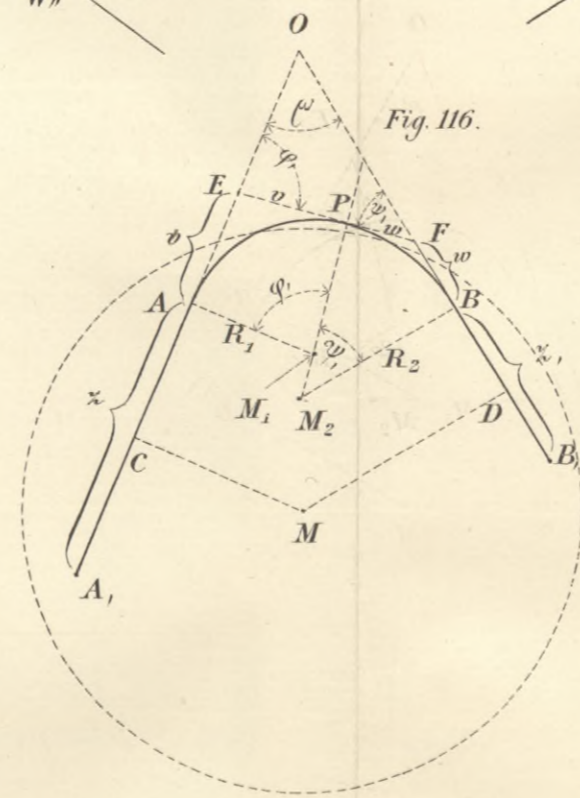


Fig. 115.

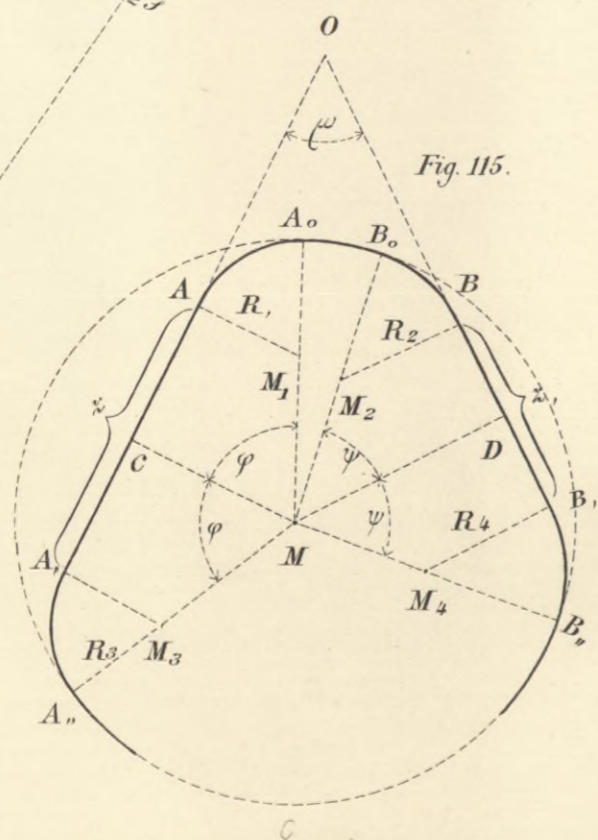


Fig. 117.

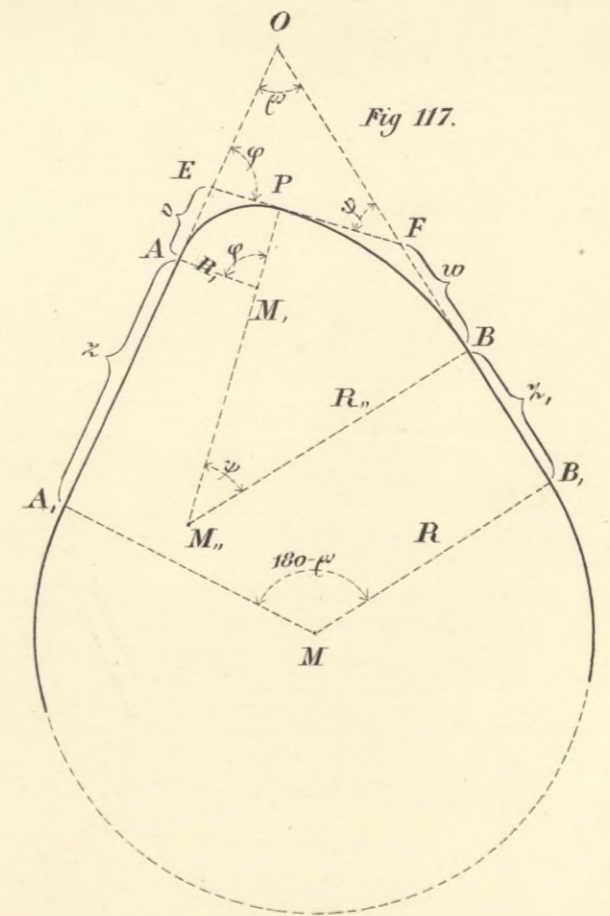
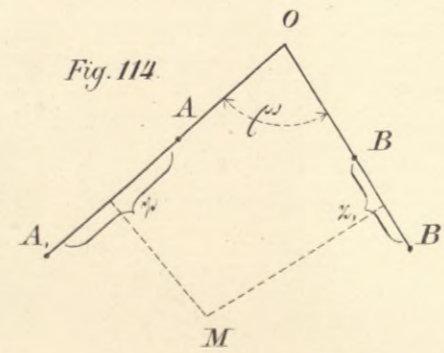


Fig. 114.



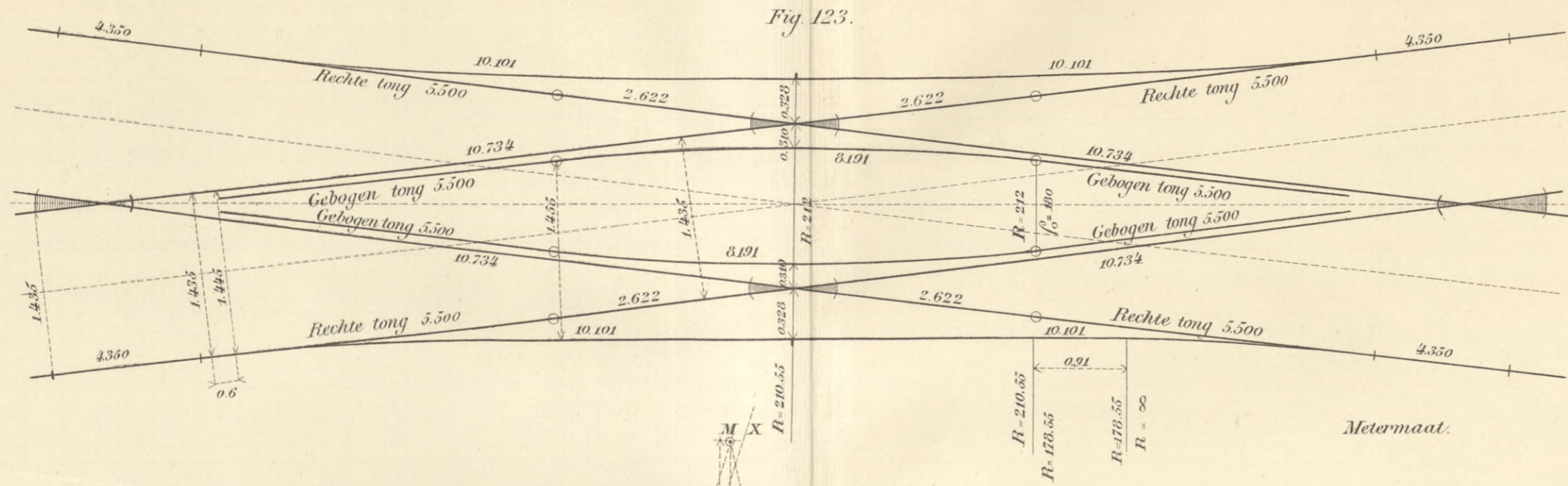


Fig. 123.

Fig. 120.

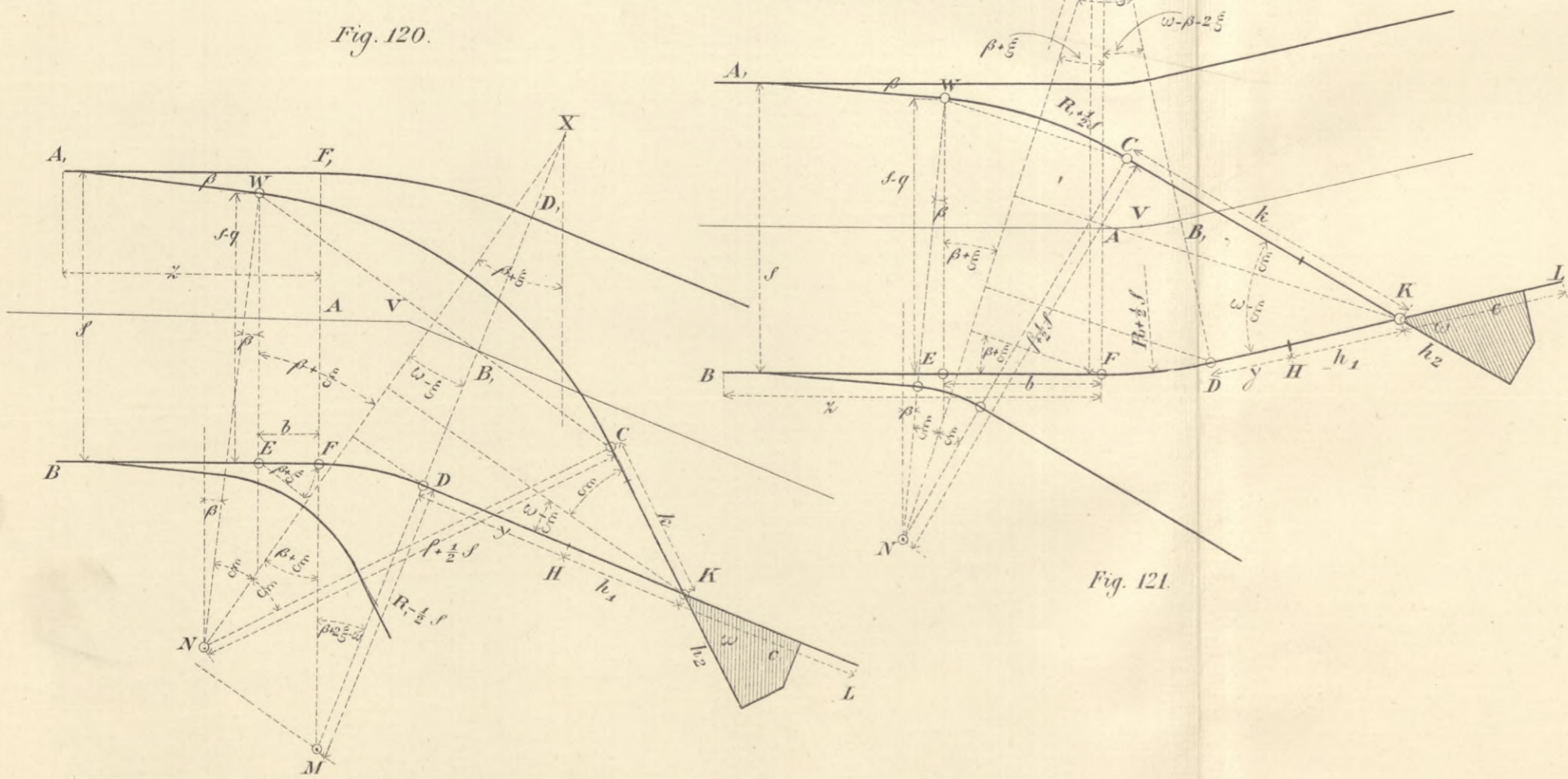
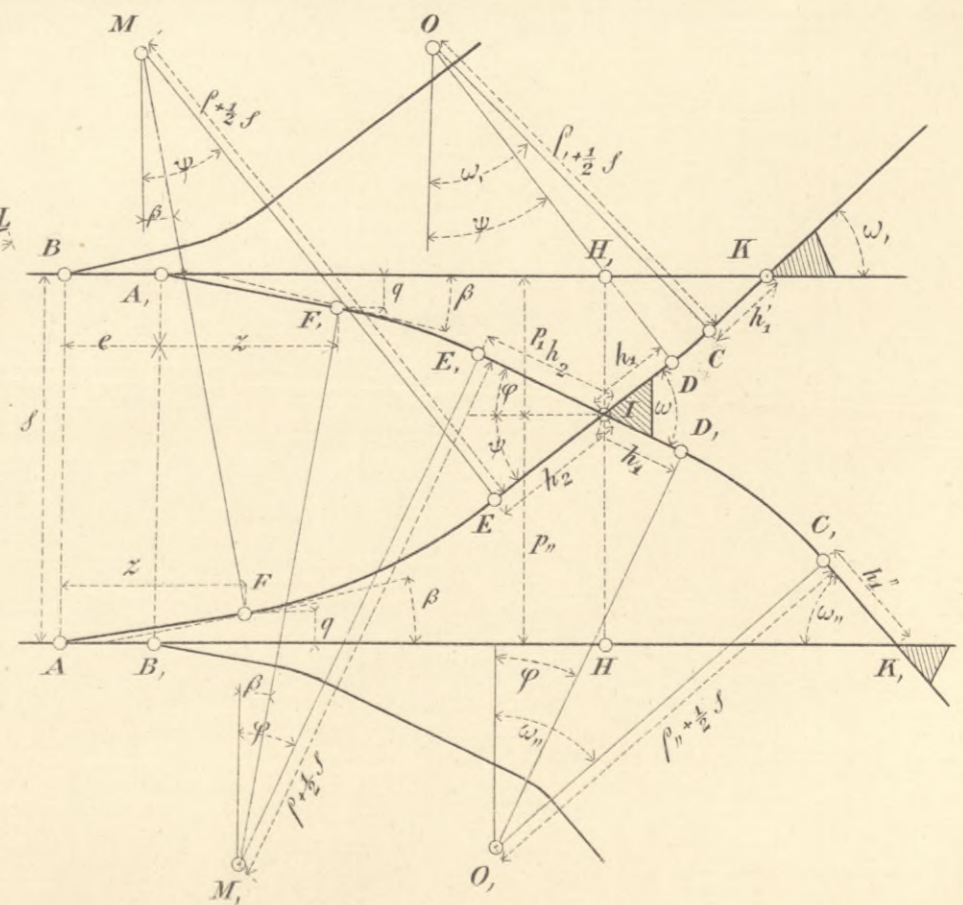


Fig. 121.

Fig. 122.





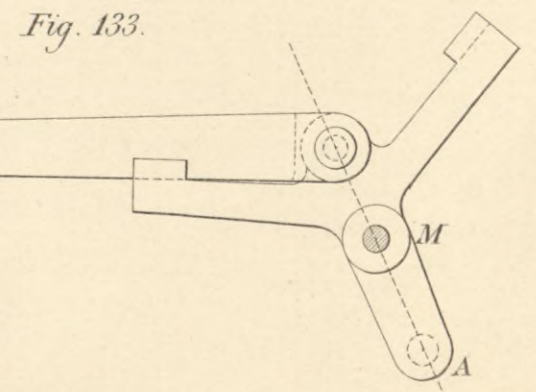
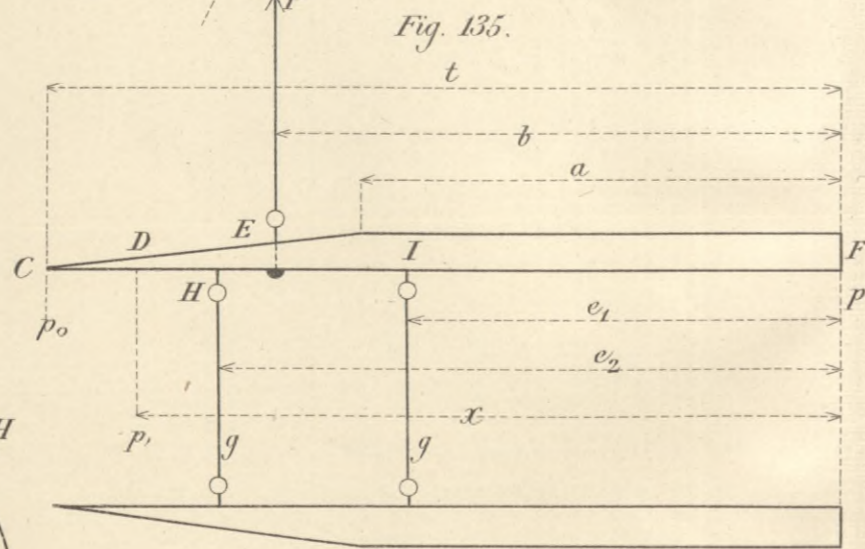
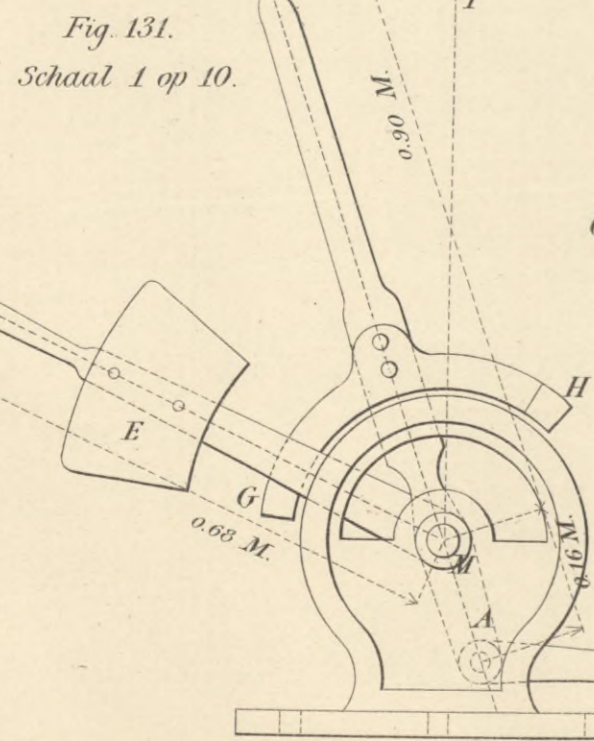
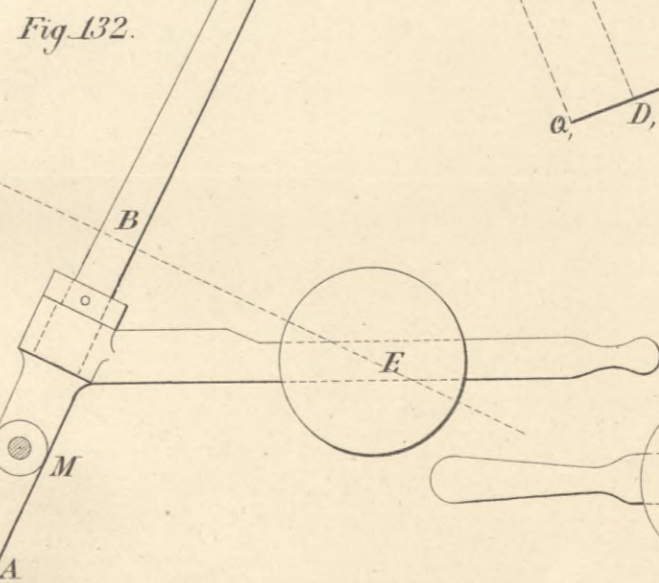
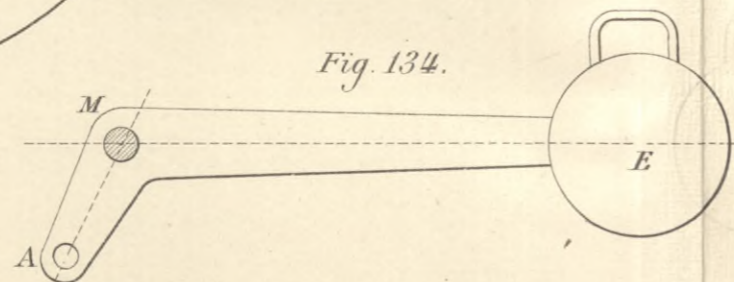
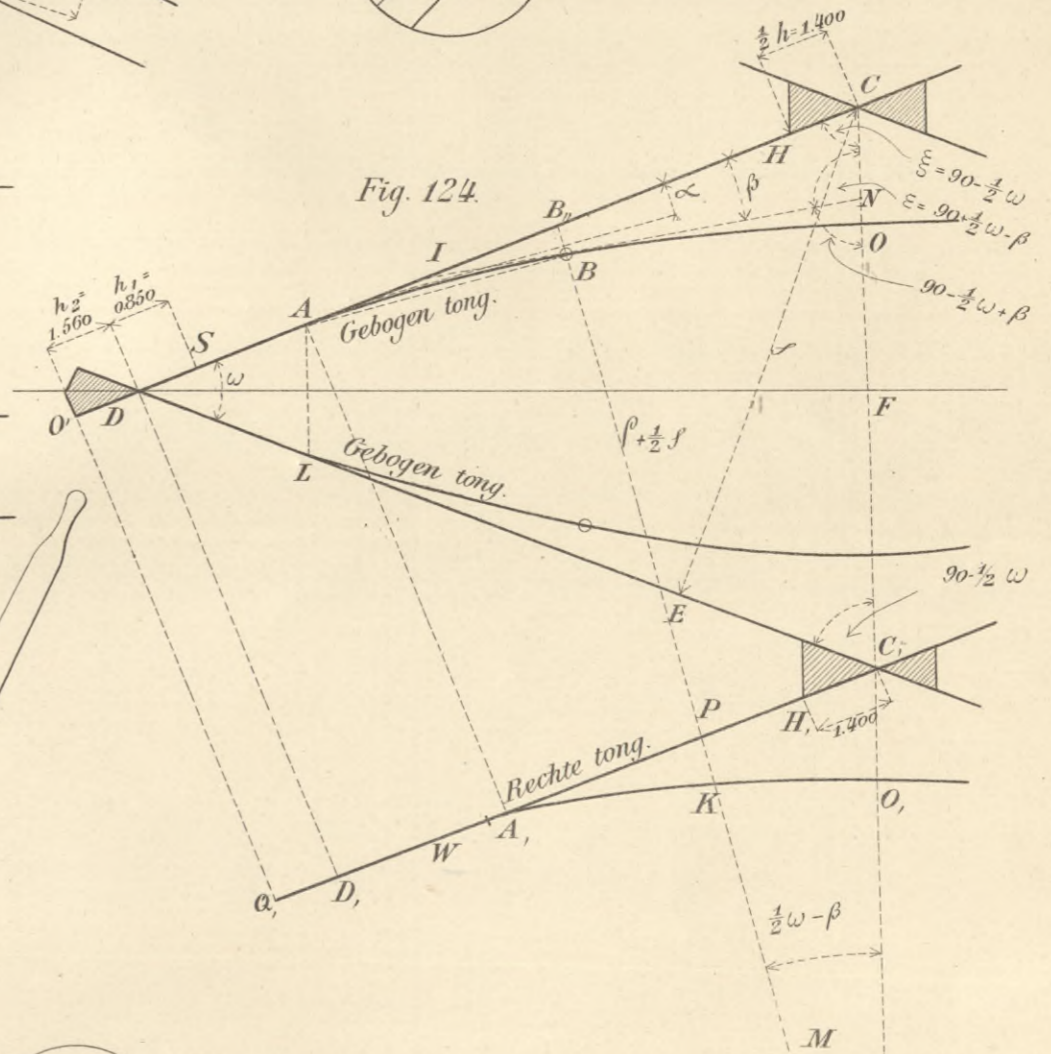
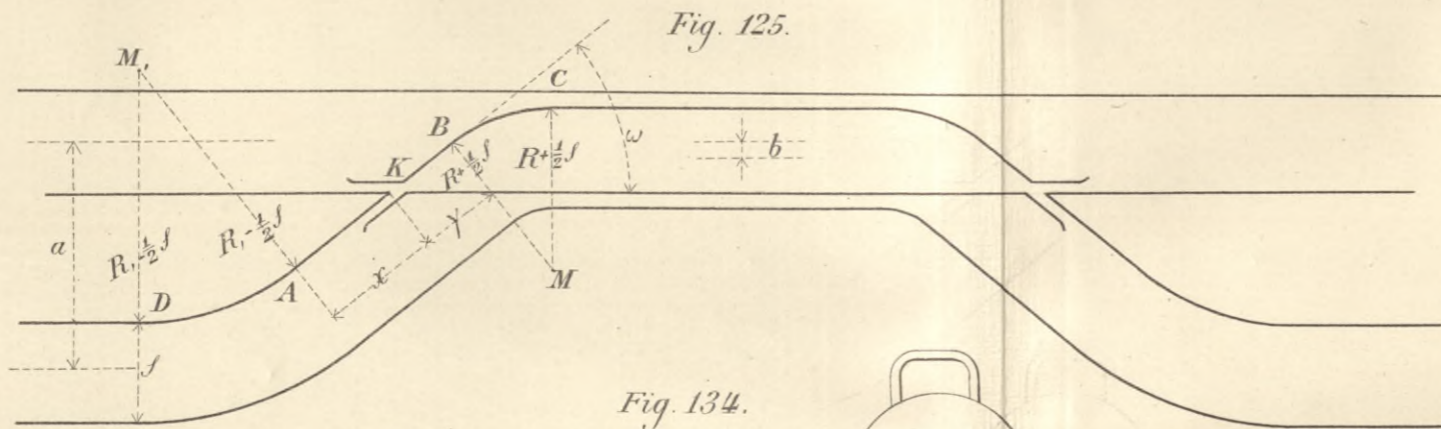
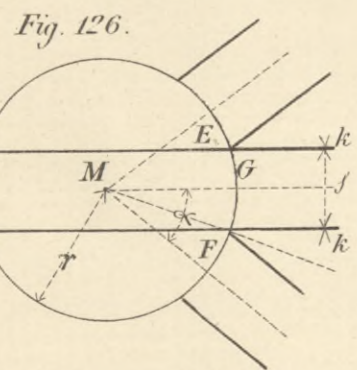
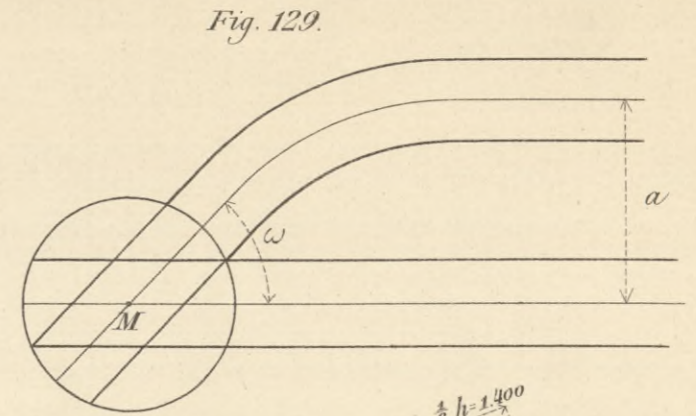
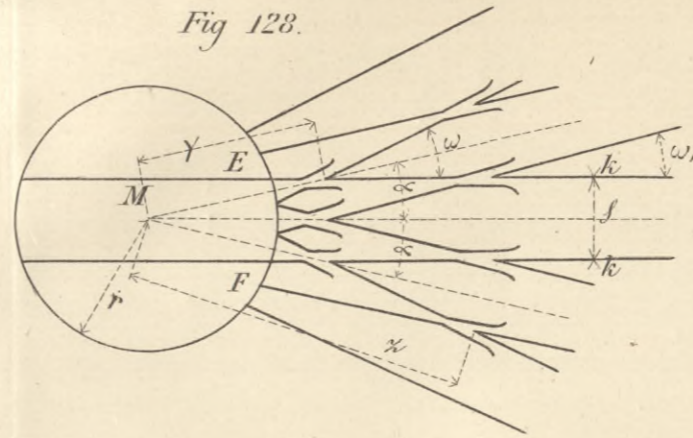
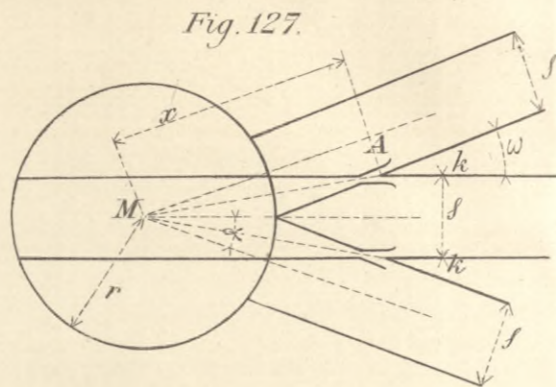
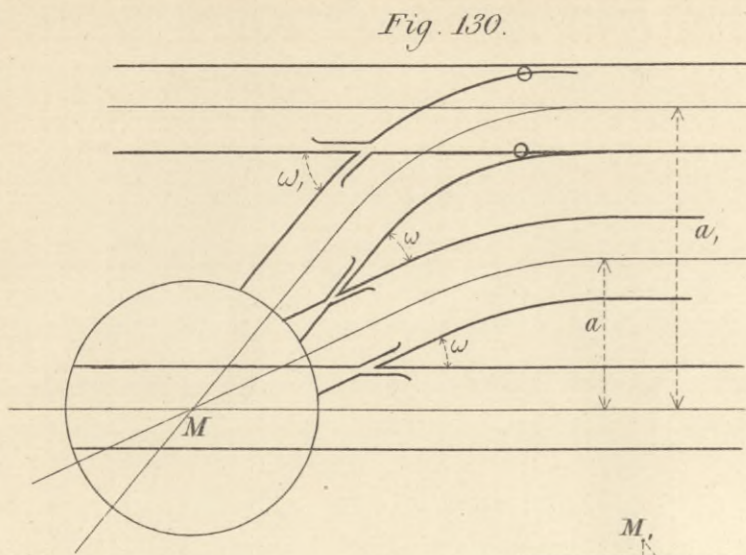


Fig. 137. Schaal 1:100.

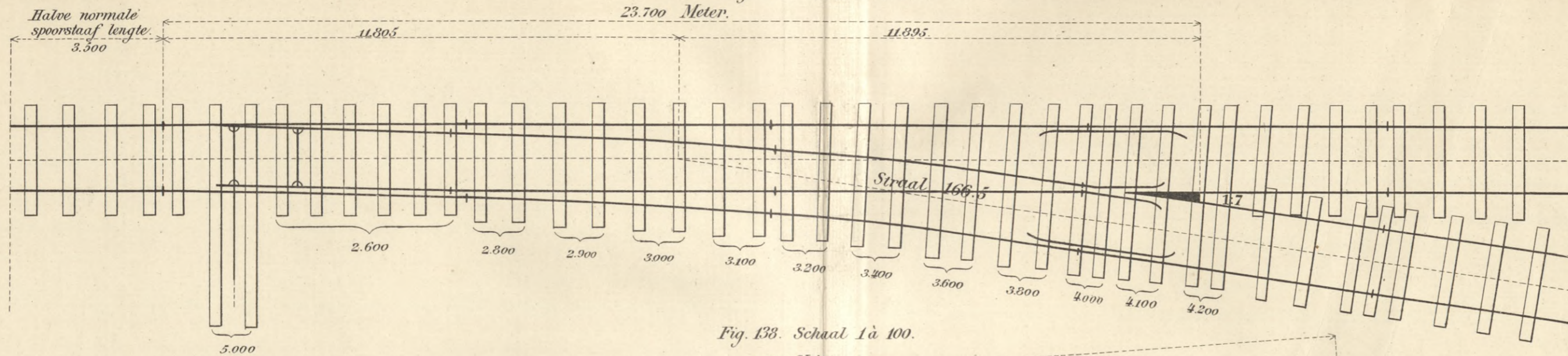


Fig. 138. Schaal 1:100.

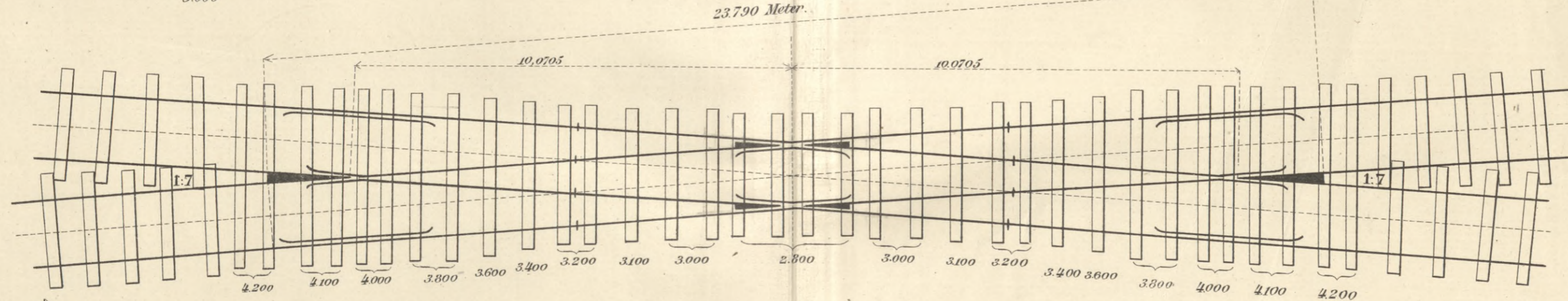


Fig. 141.

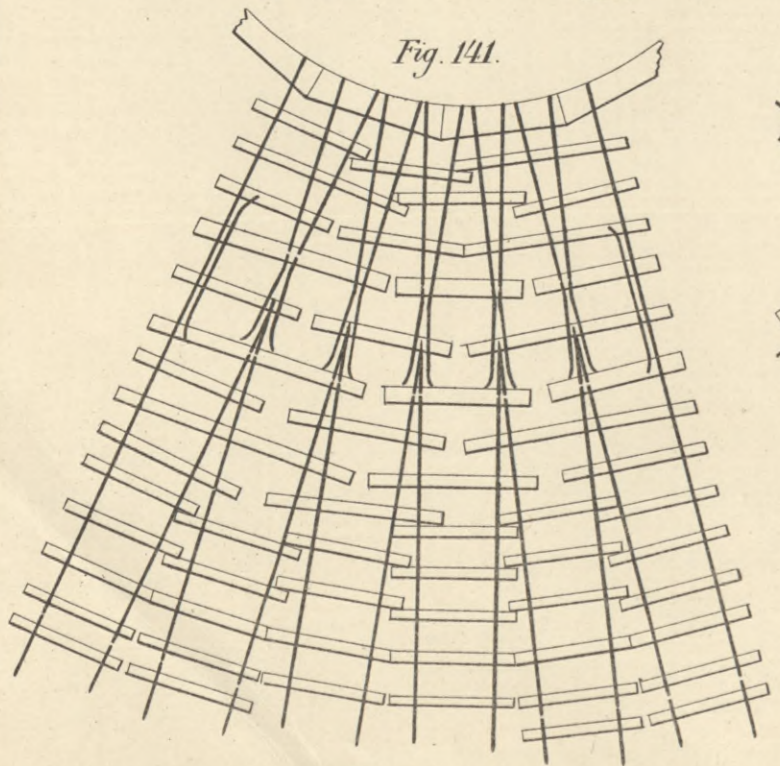


Fig. 139.

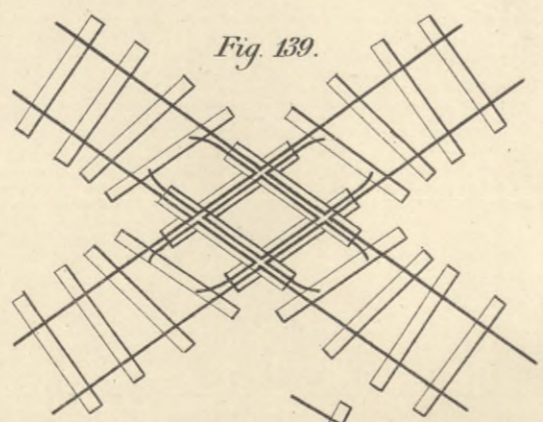


Fig. 140.

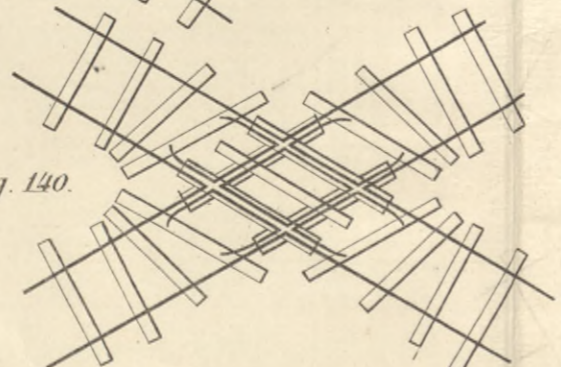
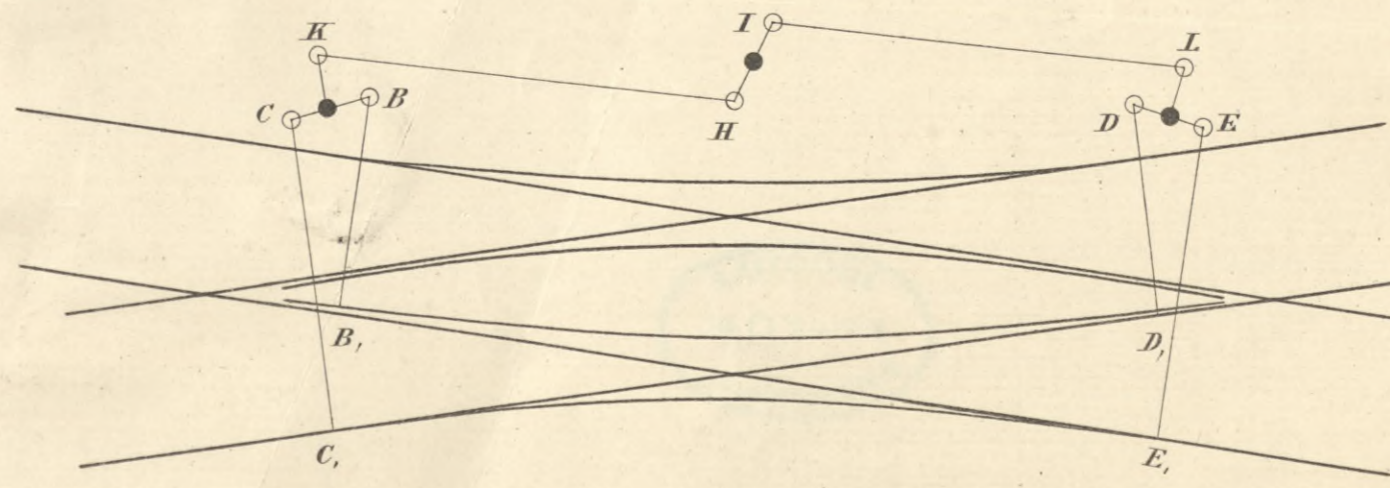


Fig. 136.





WYDZIAŁY POLITECHNICZNE KRAKÓW

Biblioteka Politechniki Krakowskiej



IV-300961

U. J. Zam. 356. 10.000.

Biblioteka Politechniki Krakowskiej



100000300860