



Biblioteka Politechniki Krakowskiej



100000300861

THE NEW YORK PUBLIC LIBRARY

xx  
249/6



# PLATEN

*Lan*

BEHOORENDE BIJ DE

# WATERBOUWKUNDE,

DOOR

N. H. HENKET, DR. Ch. M. SCHOLS EN J. M. TELDERS,

HOOGLEERAREN AAN DE POLYTECHNISCHE SCHOOL TE DELFT.

MET MEDEWERKING VAN

VERSCHILLENDE INGENIEURS.



DERDE DEEL (3<sup>e</sup> gedeelte.)

Afd. XIV. Bruggen.

*J. H. 17433*

'S-GRAVENHAGE, DE GEBROEDERS VAN CLEEF.

*III. C. 4a*

*xx  
249/6*



IV - 300957

~~III 18242~~

Akc. Nr. 1050/52

PPH-D-277/207



Wipbrug bij Spijkerboor in den jaagweg langs het Noordhollandsch Kanaal Fig. 5.

Fig. 5<sup>a</sup> Opstand (1:100)

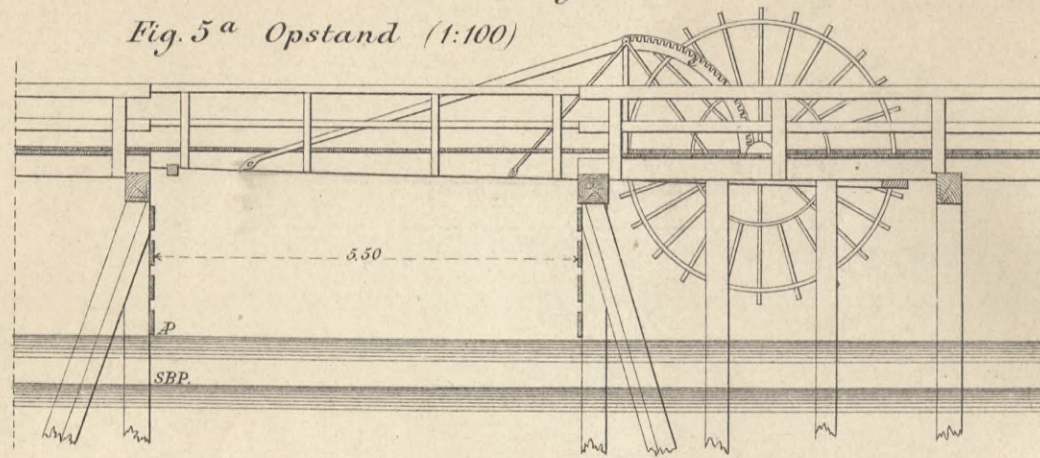
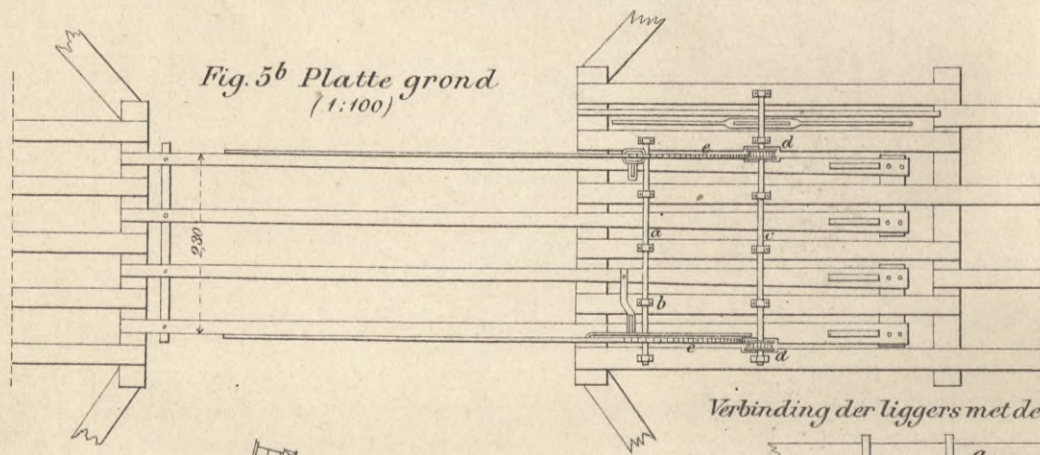

Fig. 5<sup>b</sup> Platte grond (1:100)



Verbinding der liggers met de as

Fig. 1.

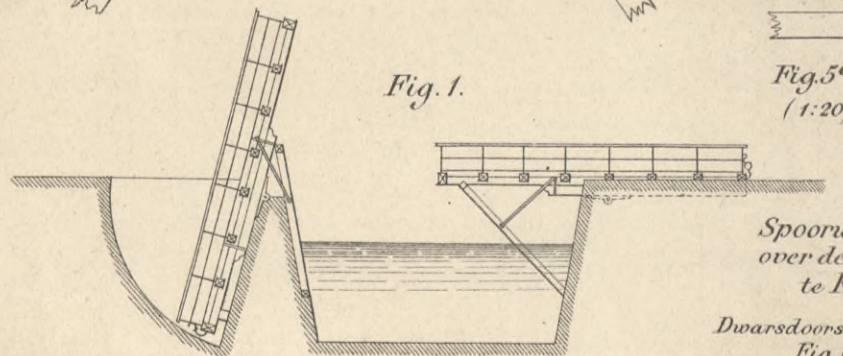
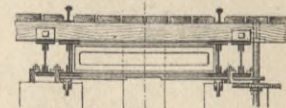

Fig. 5<sup>d</sup> (1:20)



Spoorweg Wipbrug over de Vestinggracht te Keulen Fig. 6.

Dwarsdoorsnede (over  $\alpha\beta$  Fig. 6<sup>a</sup>) Fig. 6<sup>b</sup> (1:72)



Detail Vastzettoestel Fig. 6<sup>c</sup> (1:48)

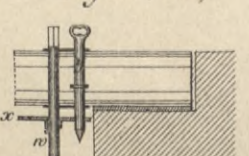
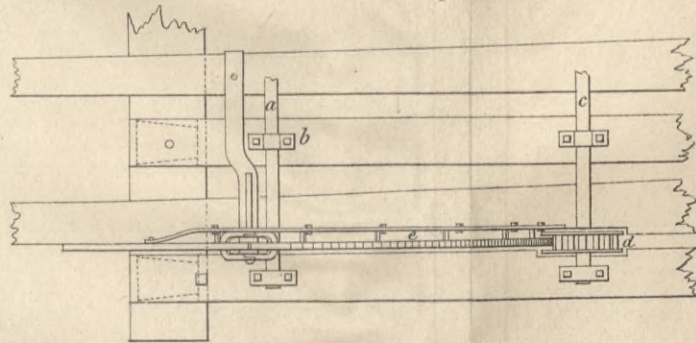
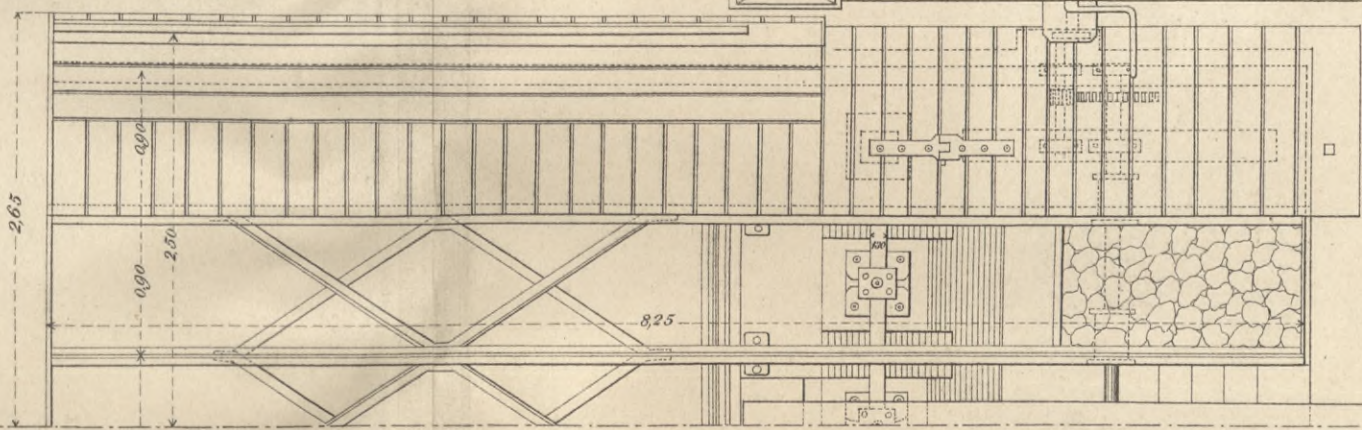

Fig. 5<sup>c</sup> Detail van den Platte grond bij de as (1:40)



Platte grond Fig. 7<sup>b</sup>



Lengte doorsnede Fig. 6<sup>a</sup> (1:72)

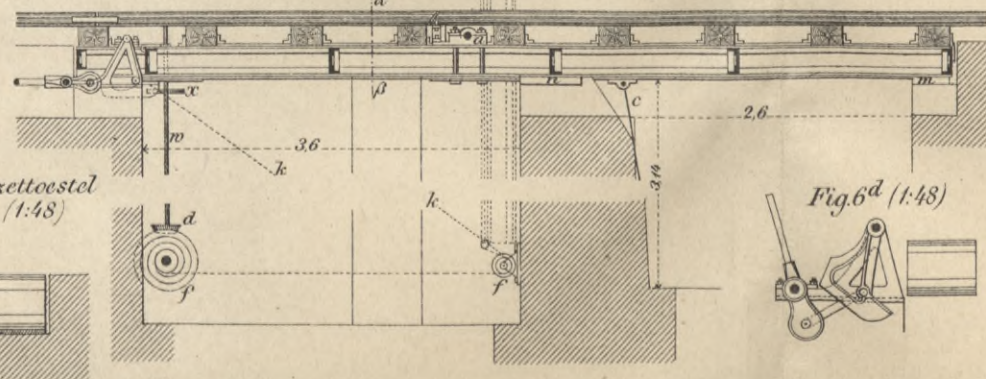
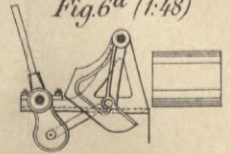
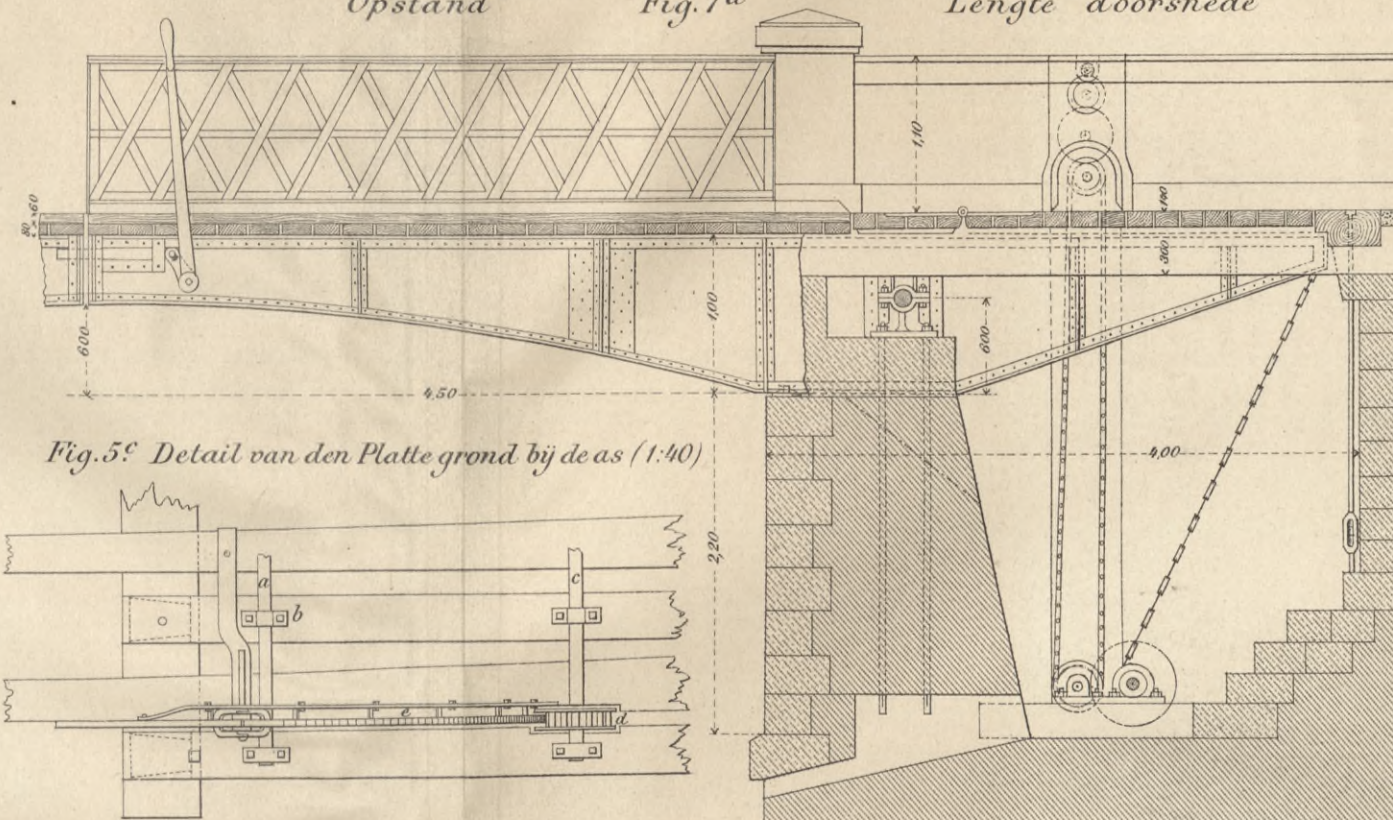

Fig. 6<sup>d</sup> (1:48)



Dubbele Wipbrug in den weg van Deva naar Montrico in Spanje Opstand Fig. 7<sup>a</sup> Lengte doorsnede



Schaal 1:50 Decim. 10 5 0 1 Meter Fig. 7<sup>a</sup> c

Fig. 7. (1:50)

Dwarsdoorsnede over den kelder

Fig. 7<sup>c</sup>

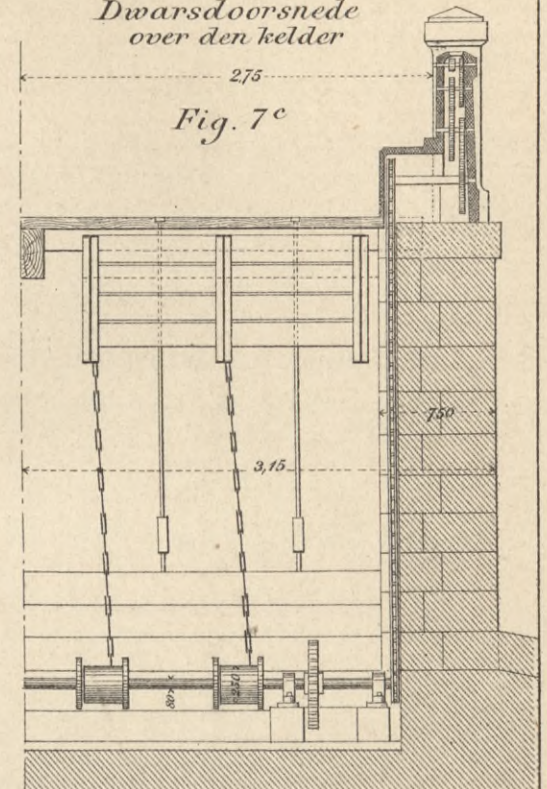

Schaal 1:200 Decim. 10 0 1 2 3 4 5 Meters Fig. 2, 8<sup>a</sup>

Schaal 1:100 Decim. 10 5 0 1 2 Meters Fig. 5<sup>a</sup> b, 8<sup>b</sup>

Nieuwe Stokkenbrug dubbele Wipbrug te Rotterdam Fig. 8 Platte grond van het raamwerk eener klap Fig. 8<sup>a</sup> (1:200)

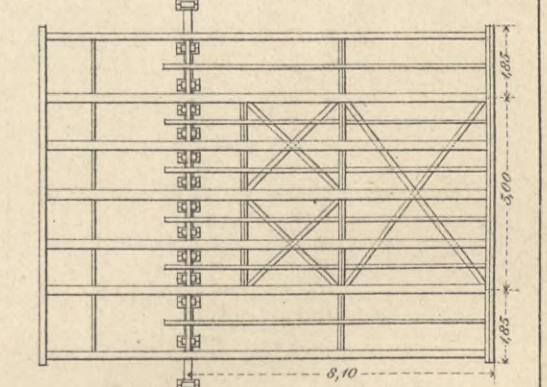

Lengte Doorsnede Fig. 8<sup>b</sup> (1:100)

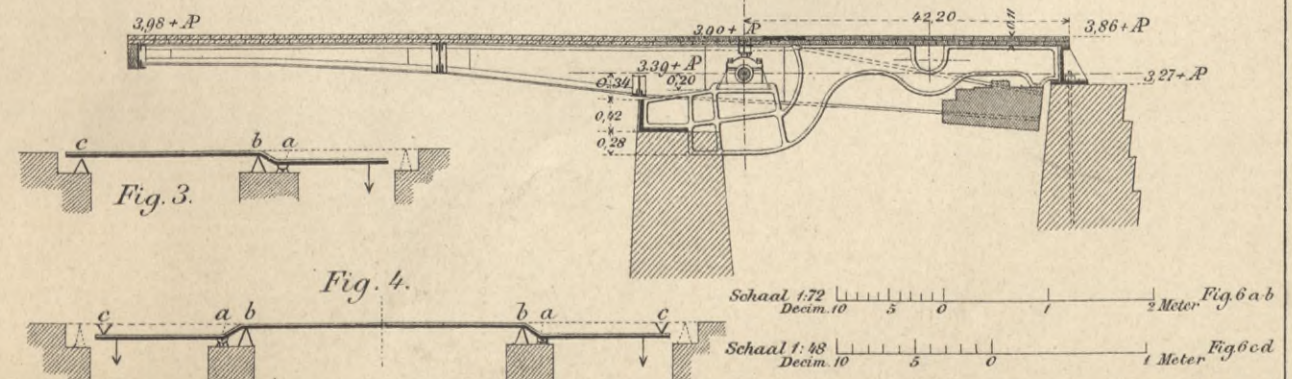

Fig. 3.

Fig. 4.

Schaal 1:72 Decim. 10 5 0 1 2 Meter Fig. 6<sup>a</sup> b

Schaal 1:48 Decim. 10 5 0 1 Meter Fig. 6<sup>d</sup>



























Dubbele Basculebrug over de Binnenhaven te Rotterdam (Fyenoord)

Lengte doorsnede over eene klep met aanzicht van een balanslijger.

Platte grond van een der kleppen.

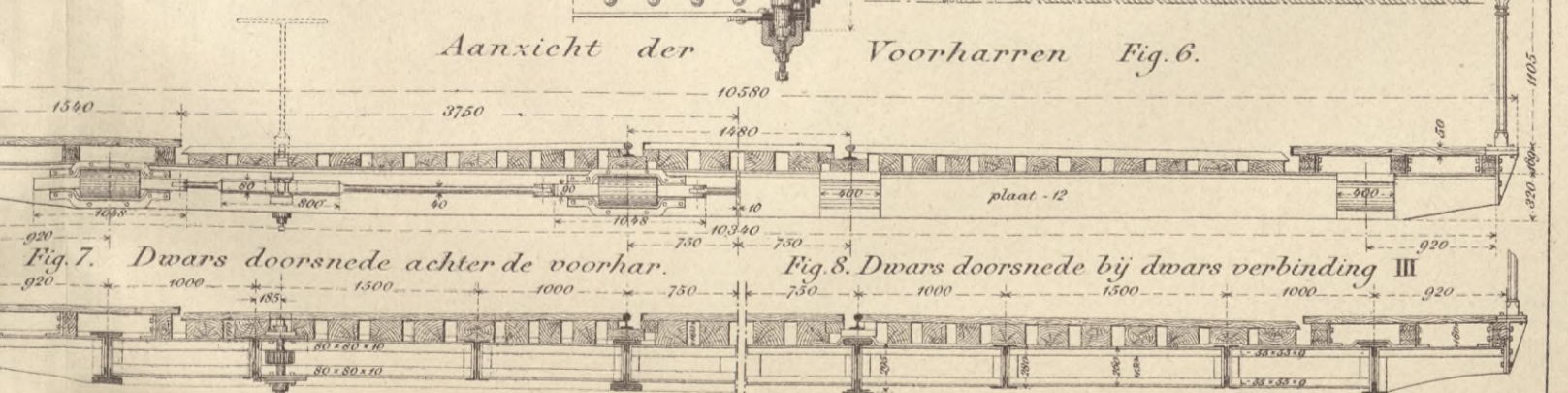
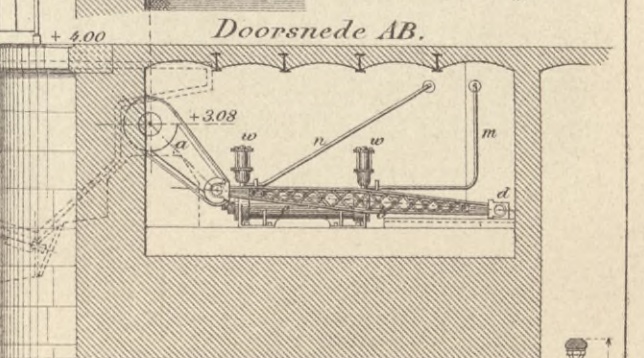
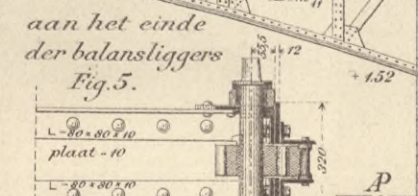
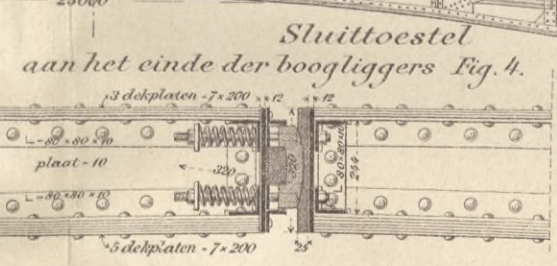
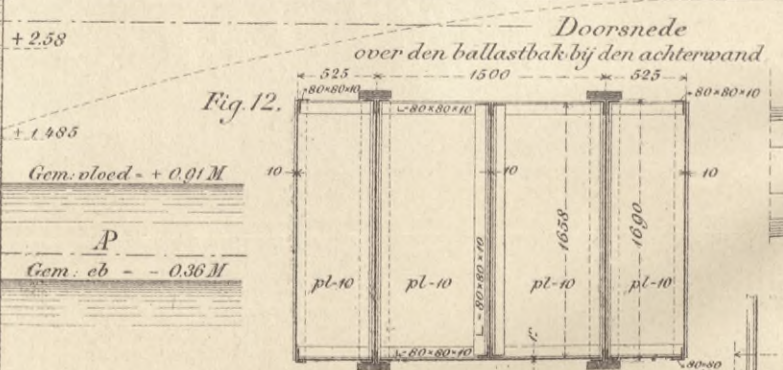
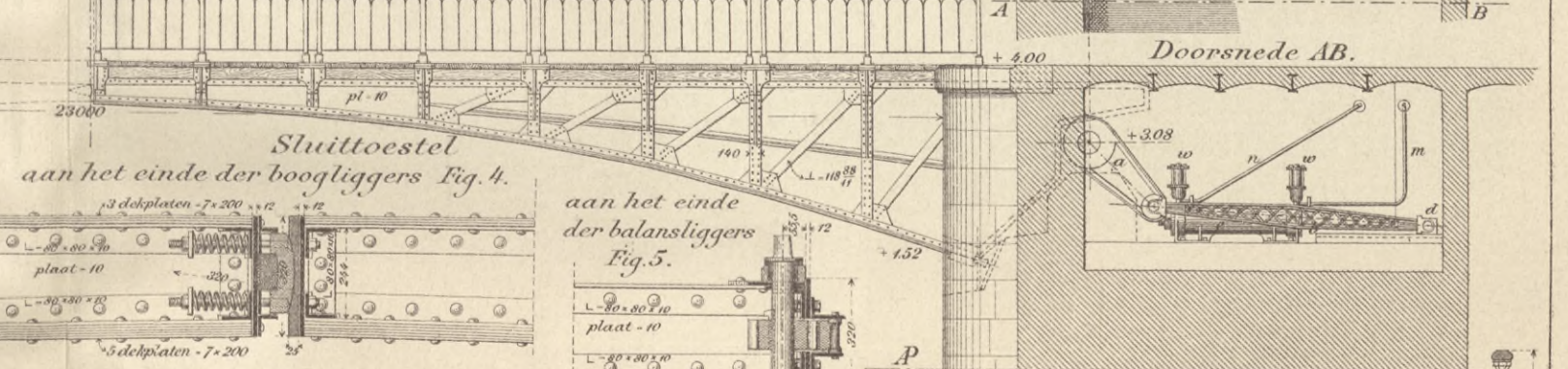
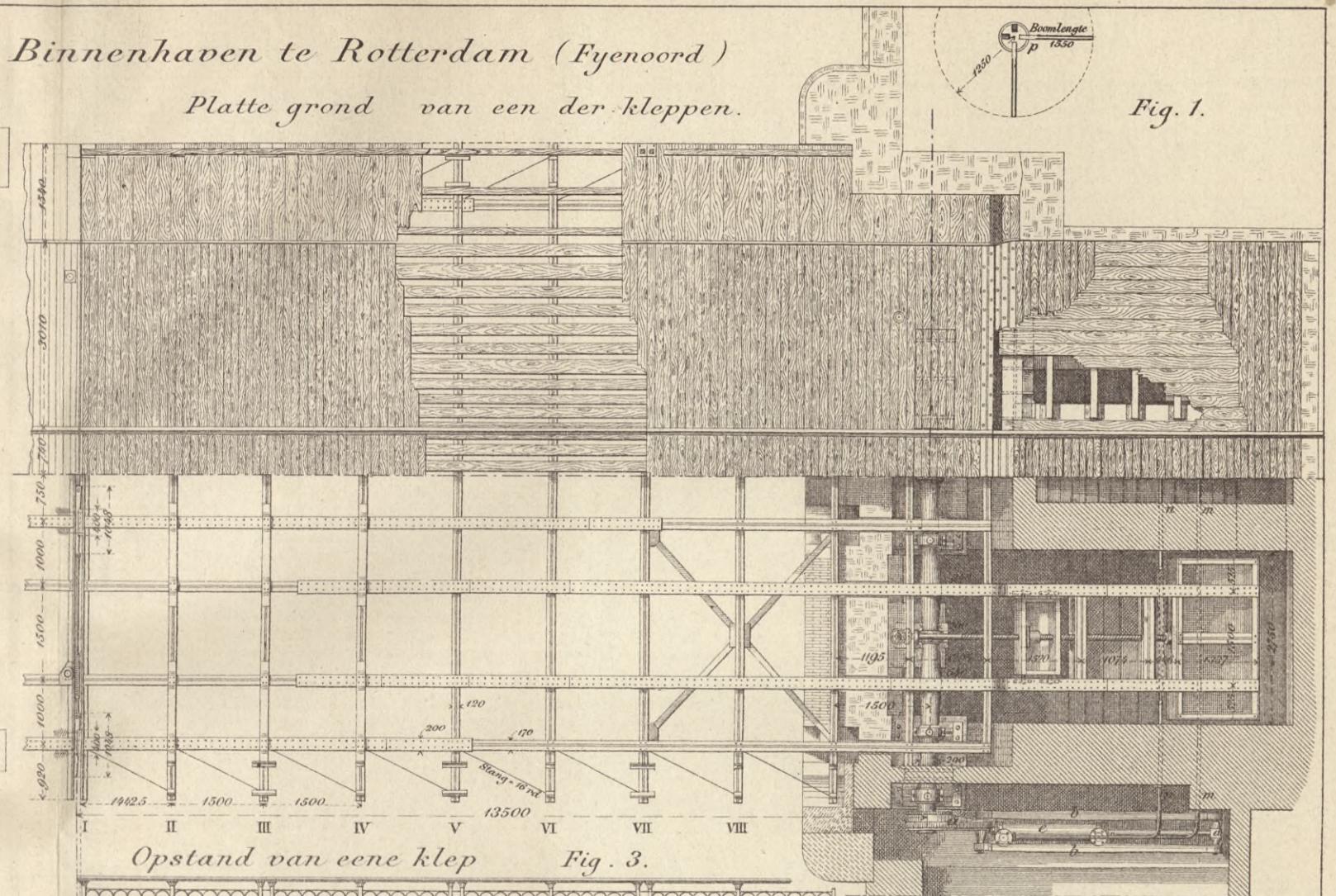
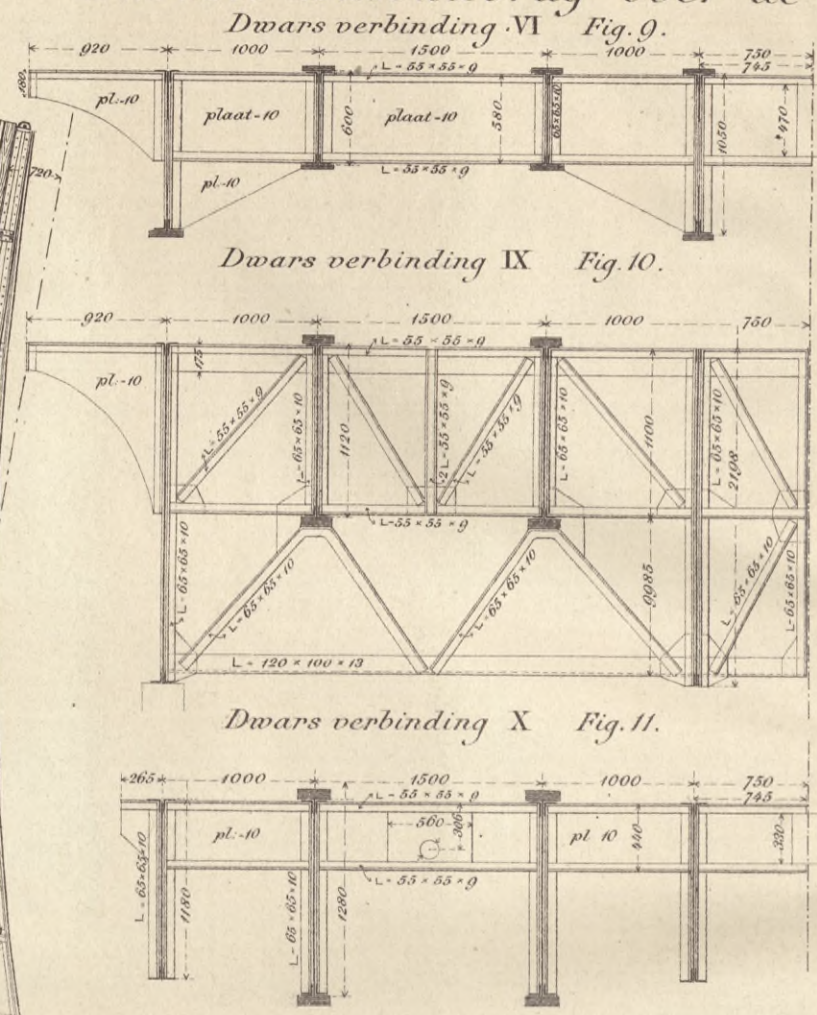
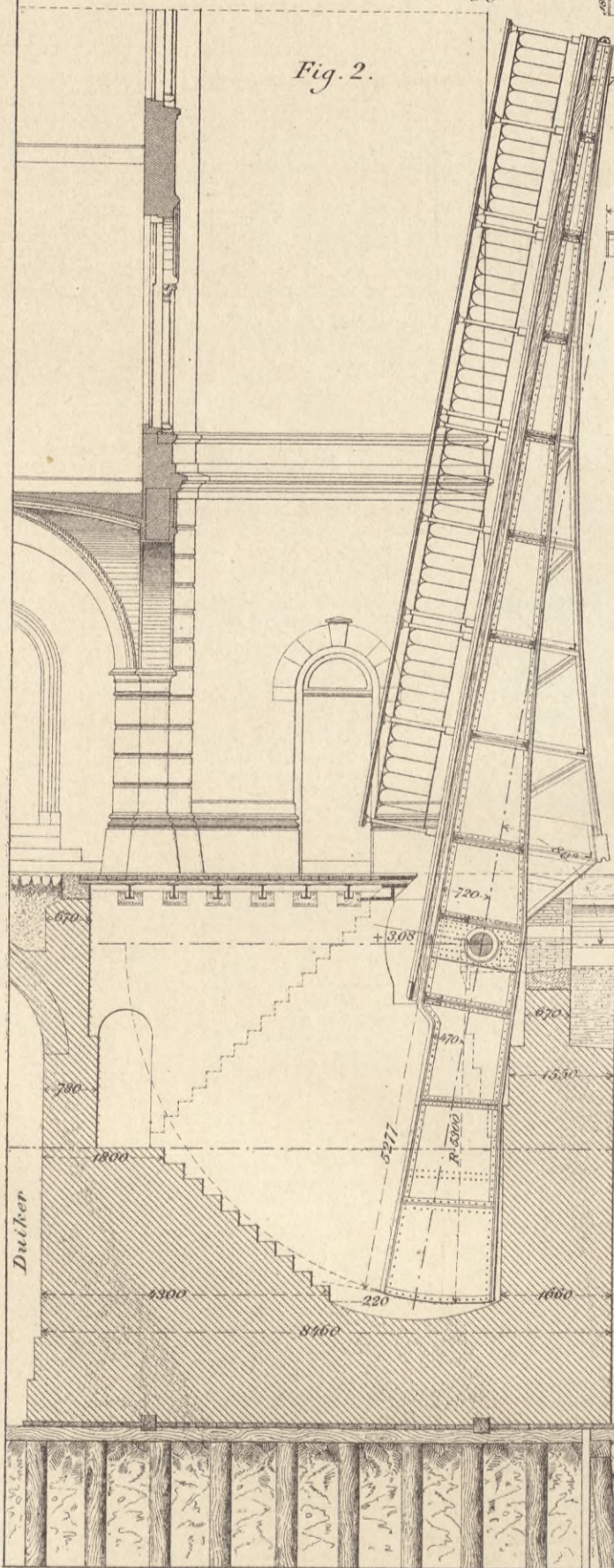

Schaal 1:20 Fig. 4 en 5      Schaal 1:50 Fig. 6-13      Schaal 1:100 Fig. 1, 2, en 3





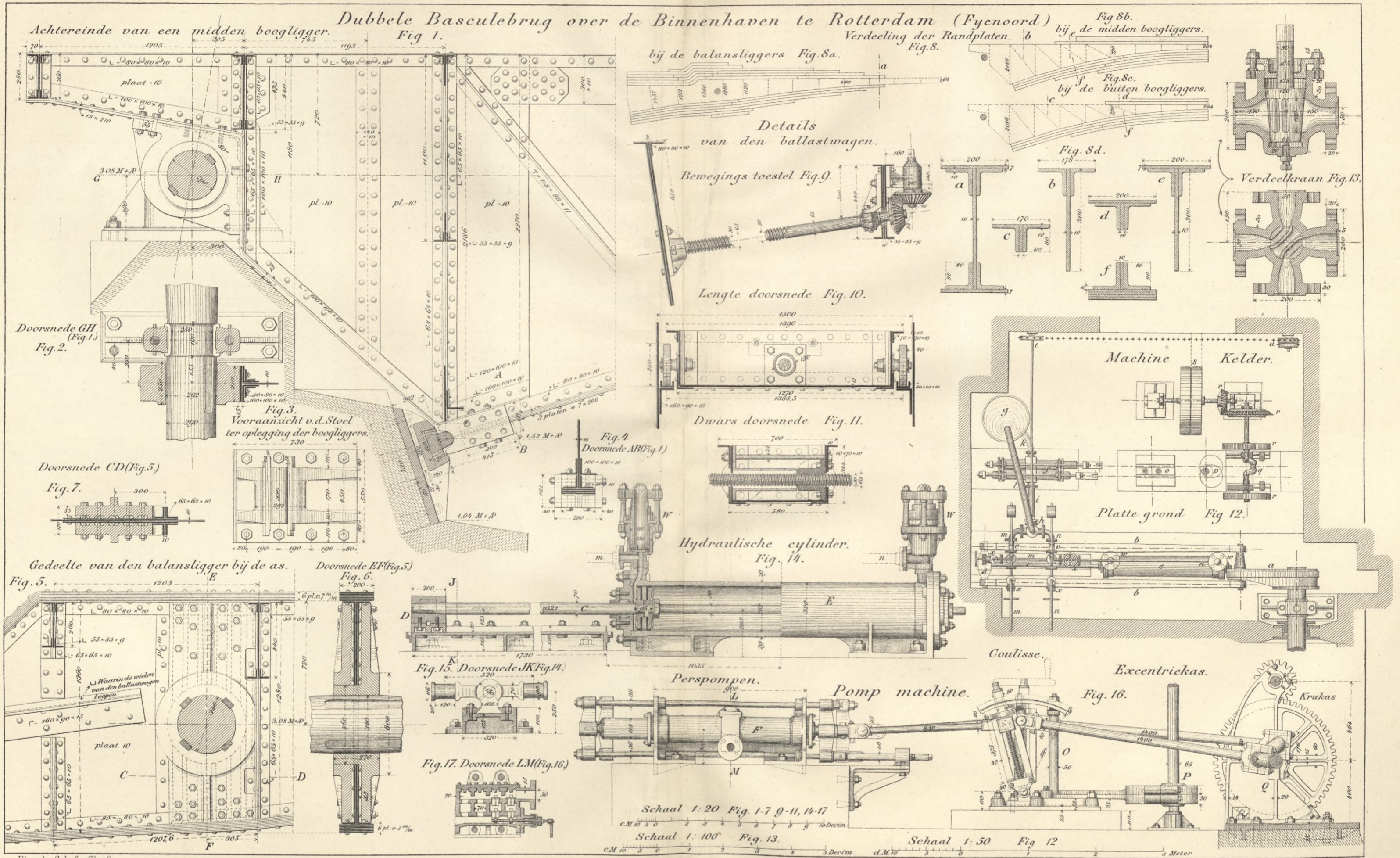













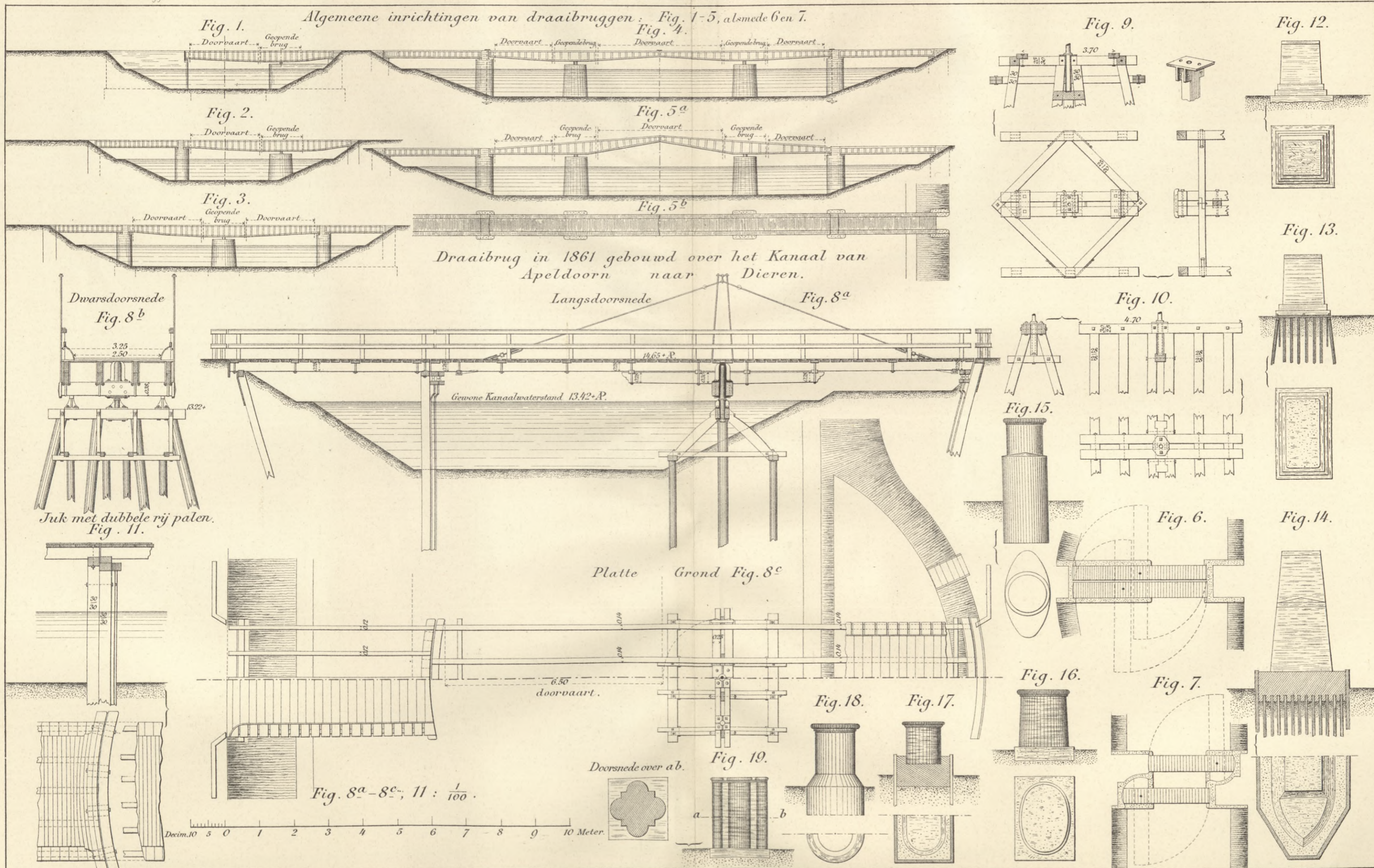





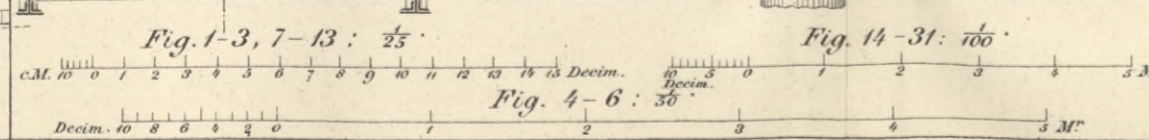
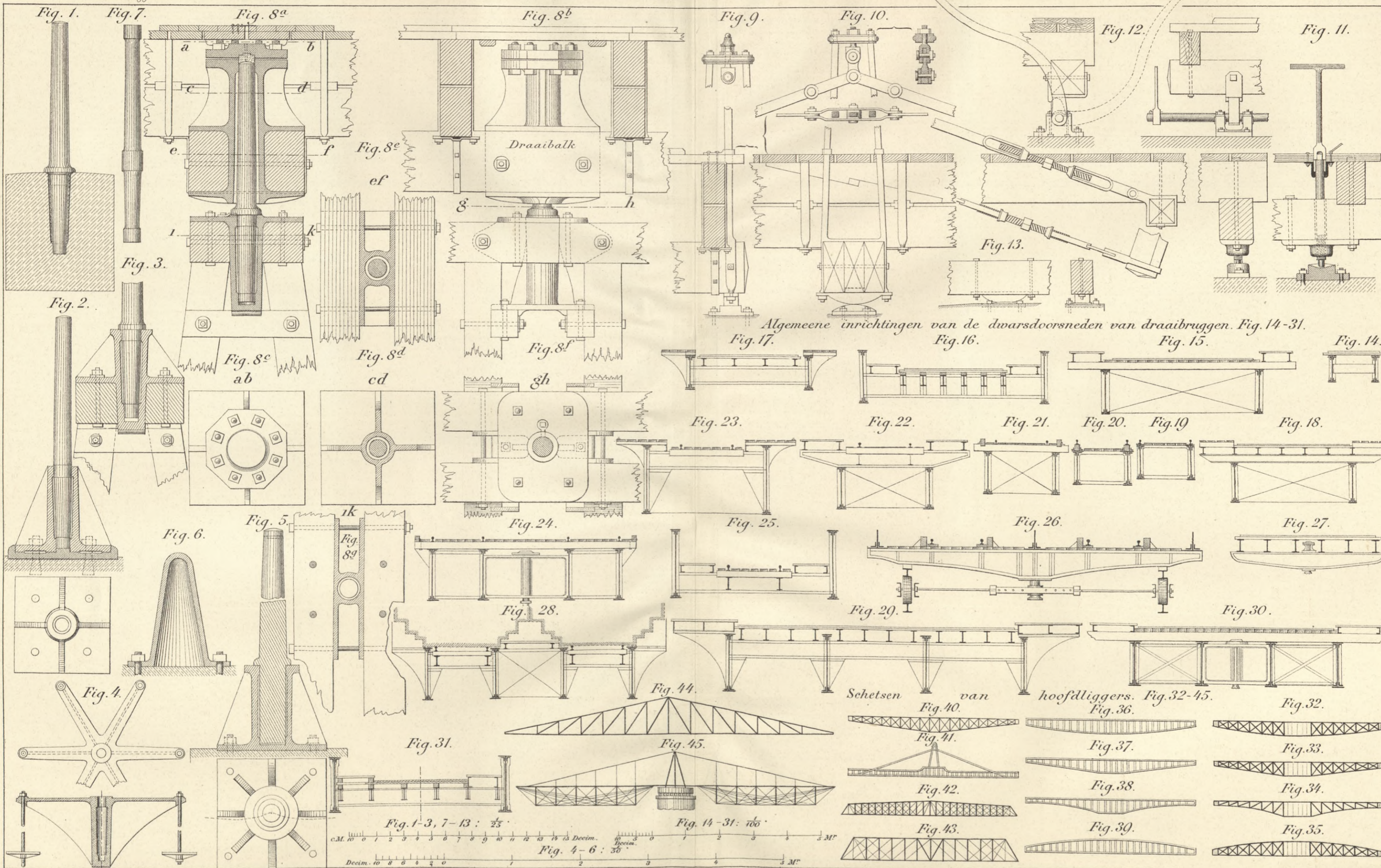







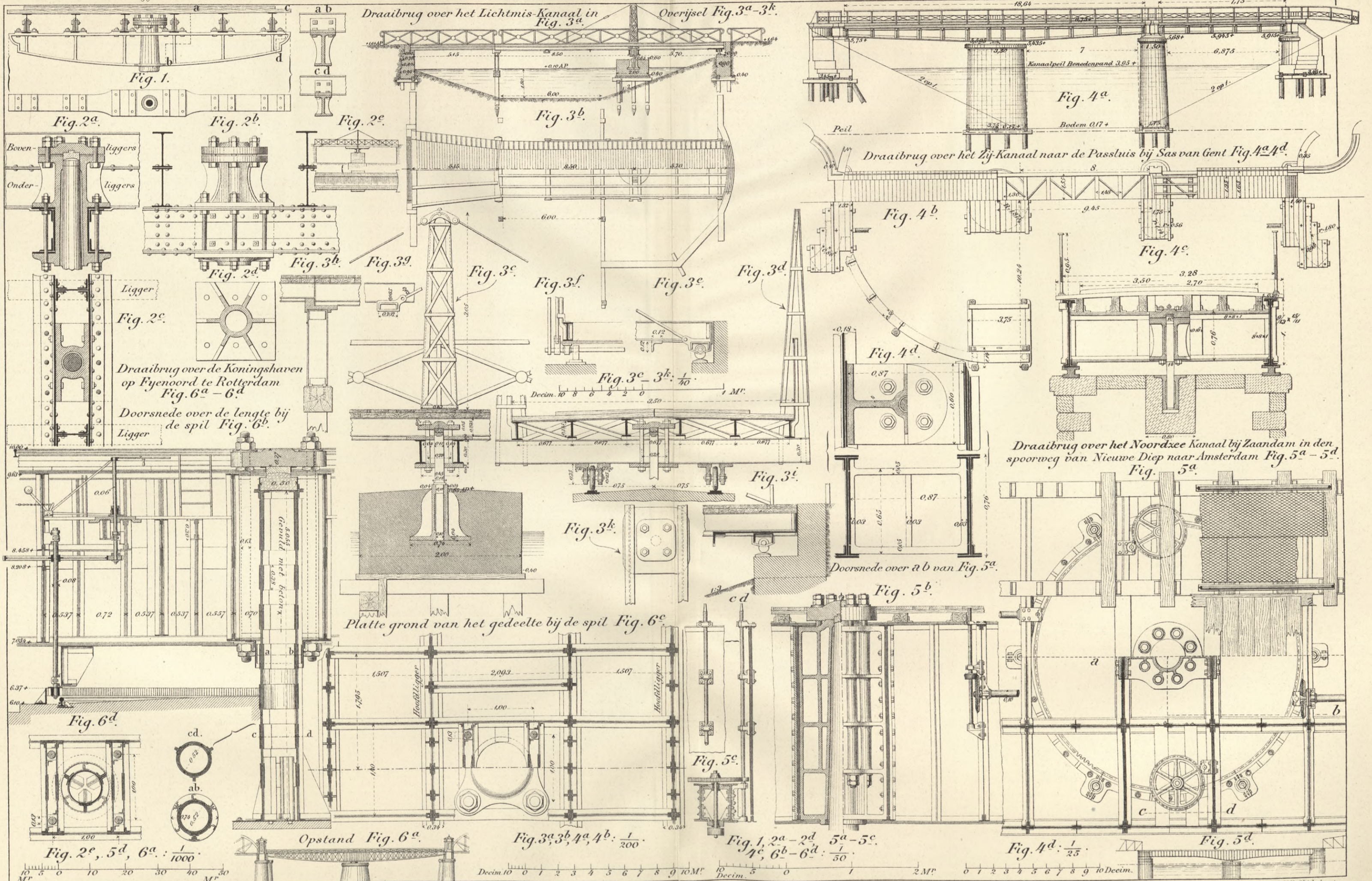





Brug over de Koningshaven (Rotterdam) Fig. 1<sup>a</sup>-1<sup>d</sup>.

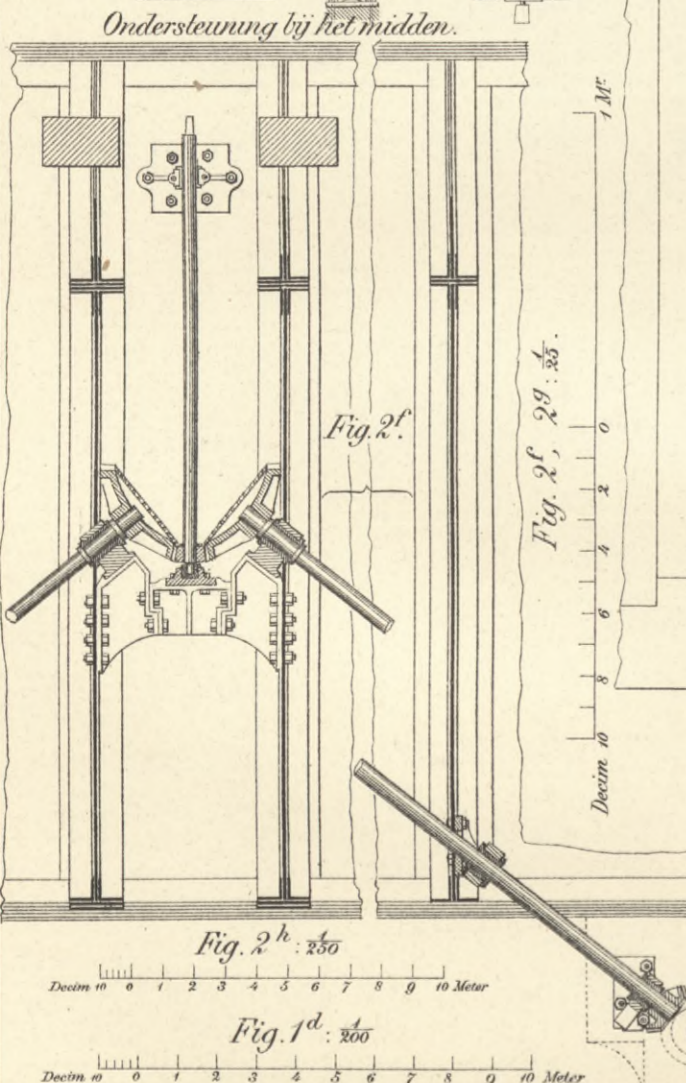
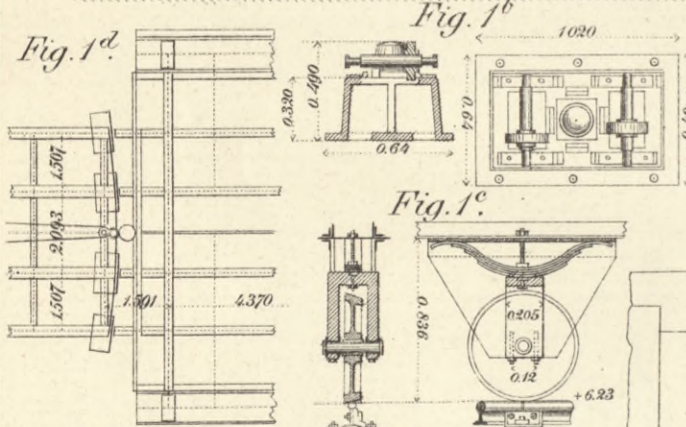
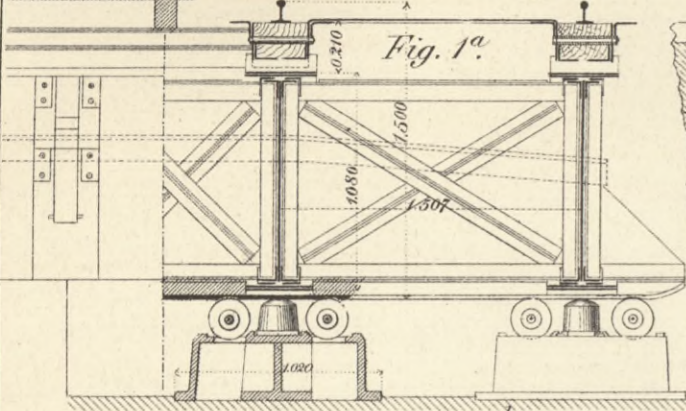

Fig. 2<sup>a</sup>.

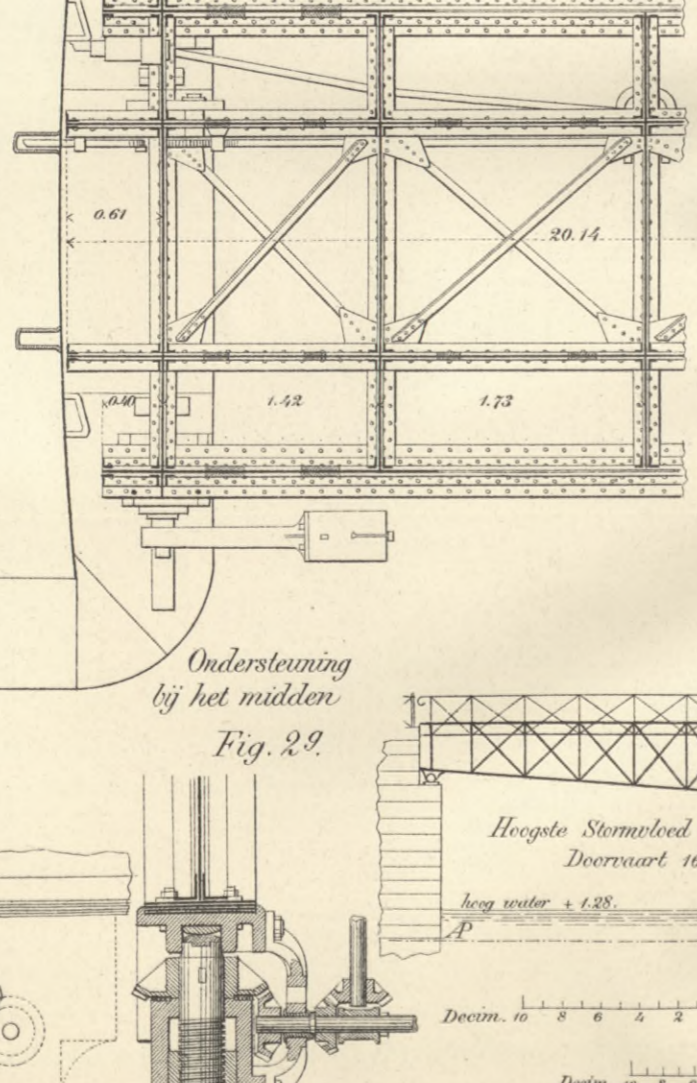
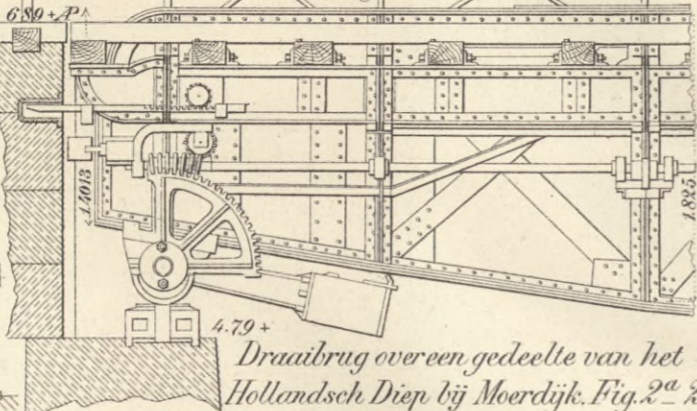
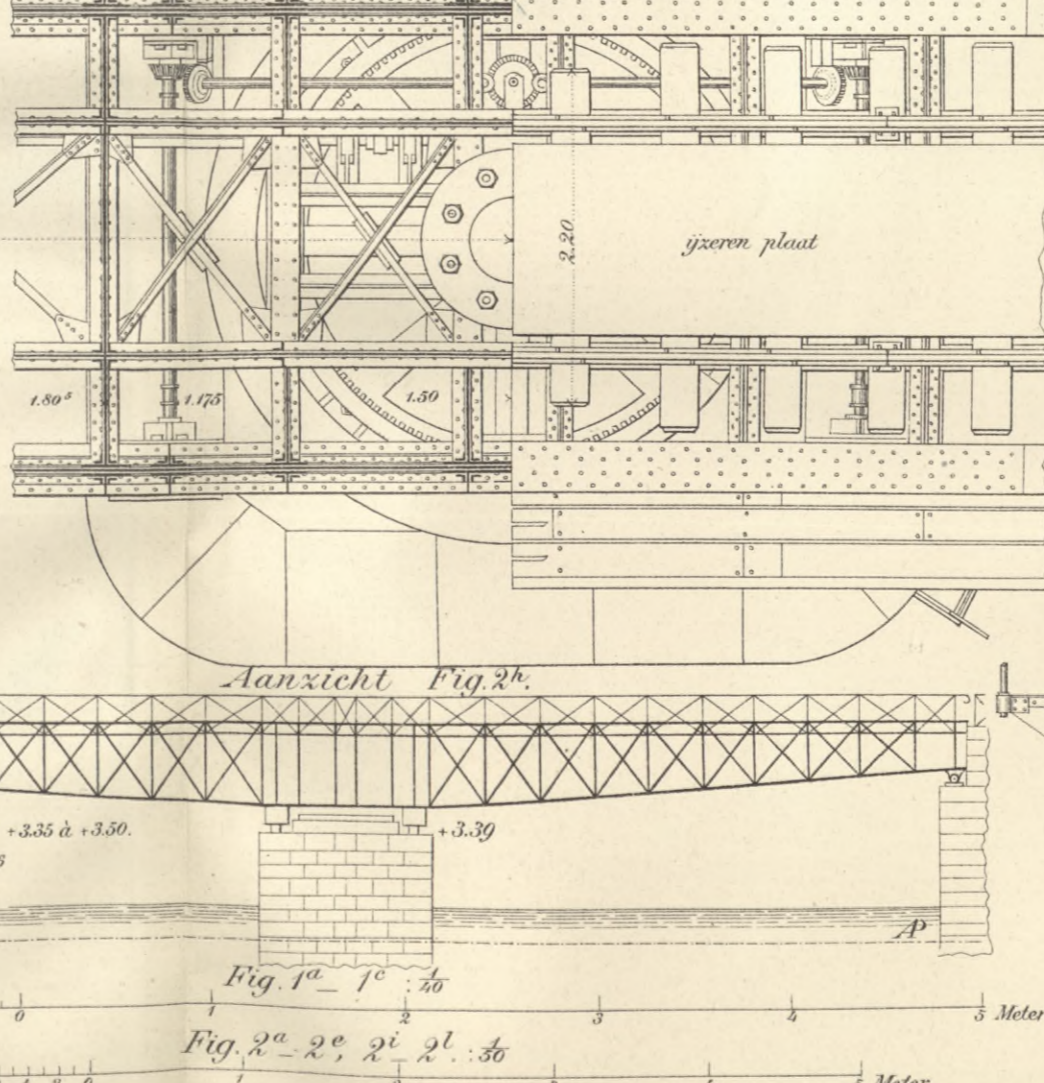
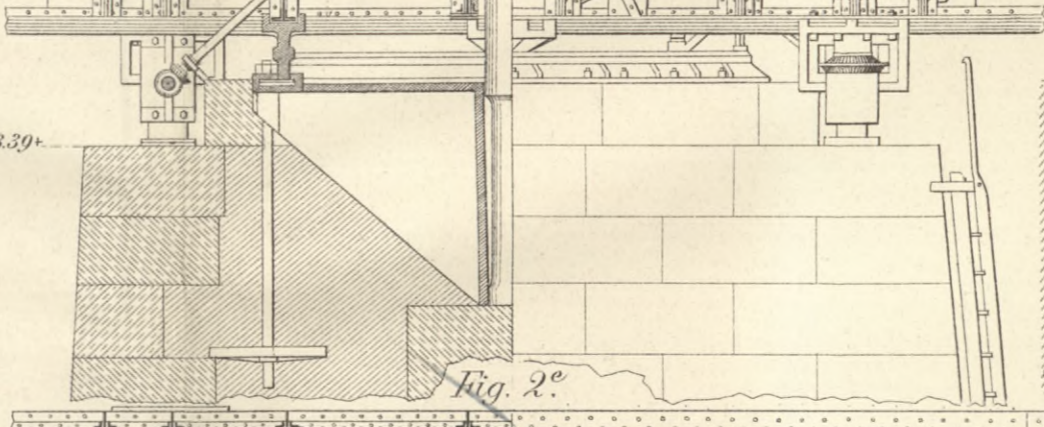
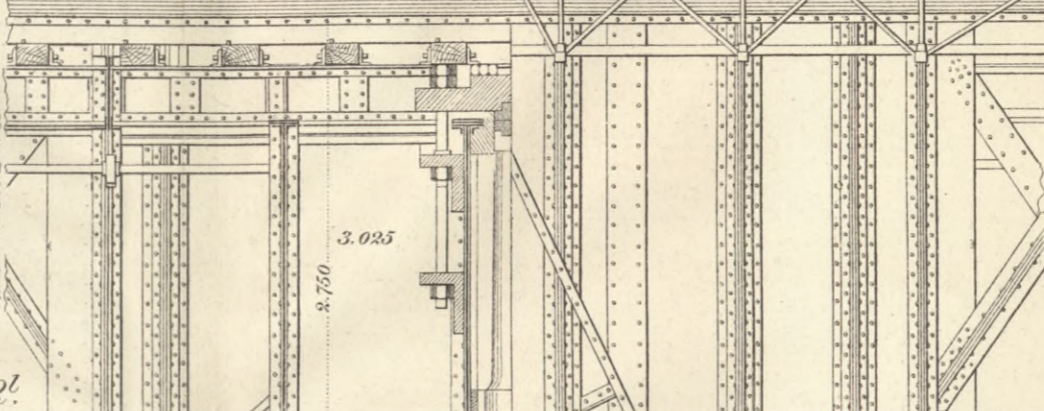
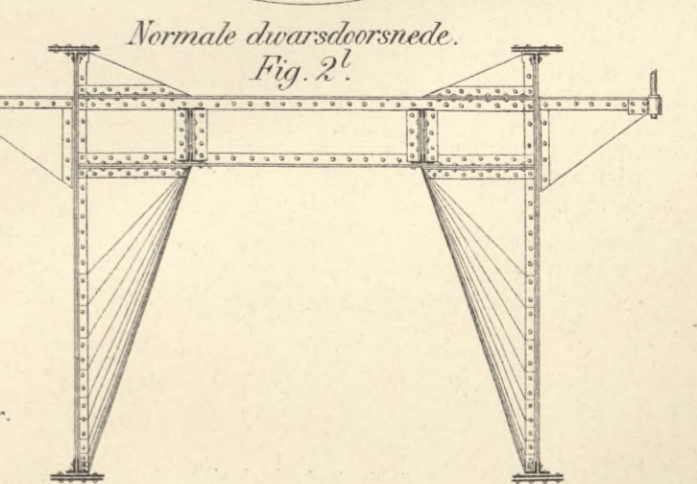
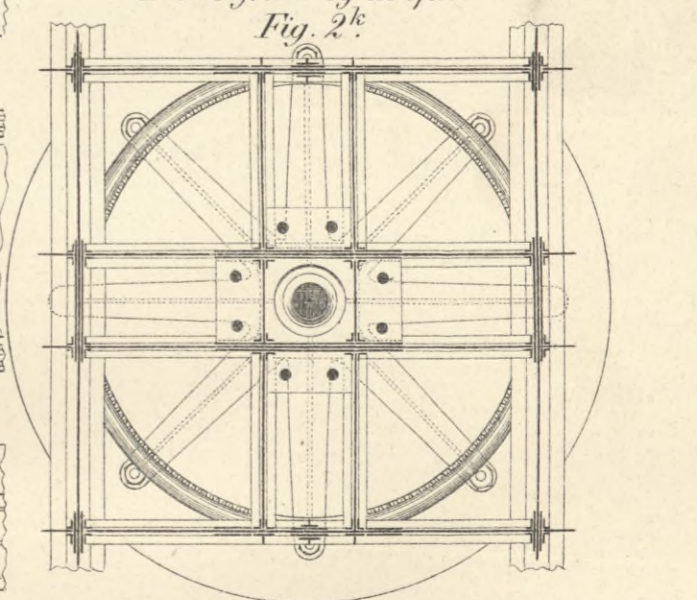
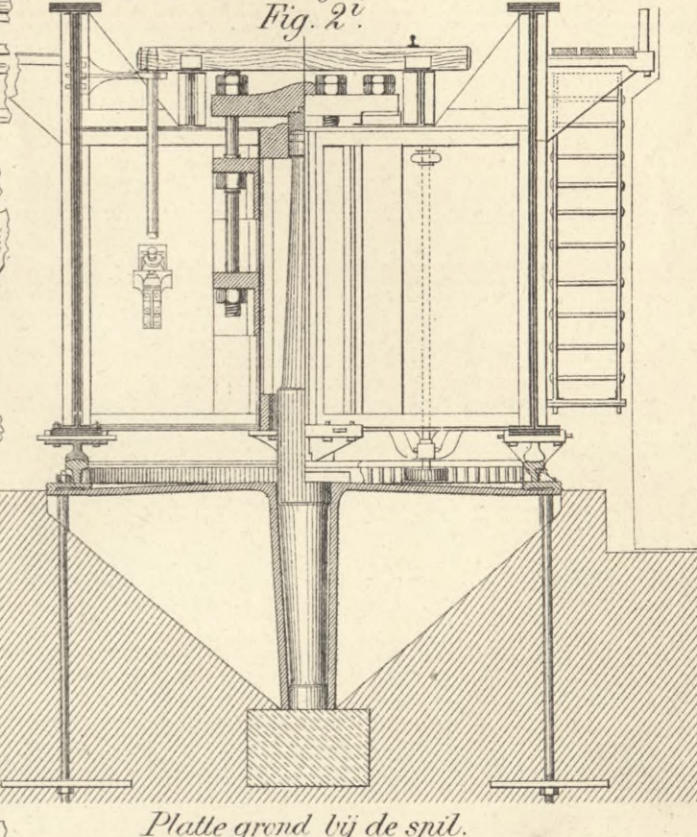

Fig. 2<sup>b</sup>.



Dwarsdoorsnede bij het midden. Fig. 2<sup>e</sup>.



Draaibrug overeen gedeelte van het Hollandsch Diep bij Moerdijk. Fig. 2<sup>a</sup>-2<sup>l</sup>.

Ondersteuning bij het midden Fig. 2g.

Aanzicht Fig. 2<sup>h</sup>.

Hoogste Stormvloed +3.35 à +3.50.  
Doorraart 16  
hoog water +1.28.

Fig. 2<sup>h</sup>: 250  
Decim. 0 1 2 3 4 5 6 7 8 9 10 Meter

Fig. 1<sup>d</sup>: 200  
Decim. 0 1 2 3 4 5 6 7 8 9 10 Meter

Fig. 1<sup>a</sup>-1<sup>c</sup>: 70  
Fig. 2<sup>a</sup>-2<sup>e</sup>, 2<sup>i</sup>-2<sup>l</sup>: 50  
Decim. 10 8 6 4 2 0 1 2 3 4 5 Meter.













Hoogste stand van hefboom en brug. Signaal onveilig. Fig. 1.

Laagste stand van hefboom en brug. Signaal onveilig. Fig. 2.

Doorsnede over A.B. van Fig. 6.

Fig. 5.

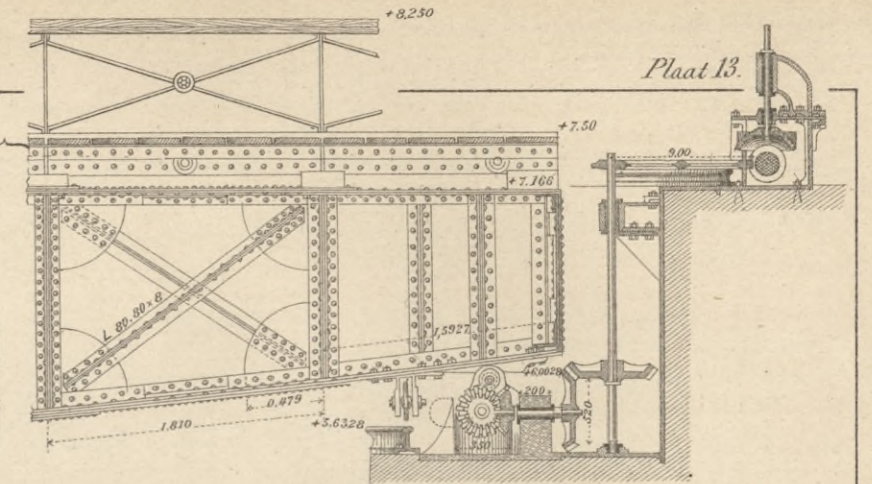
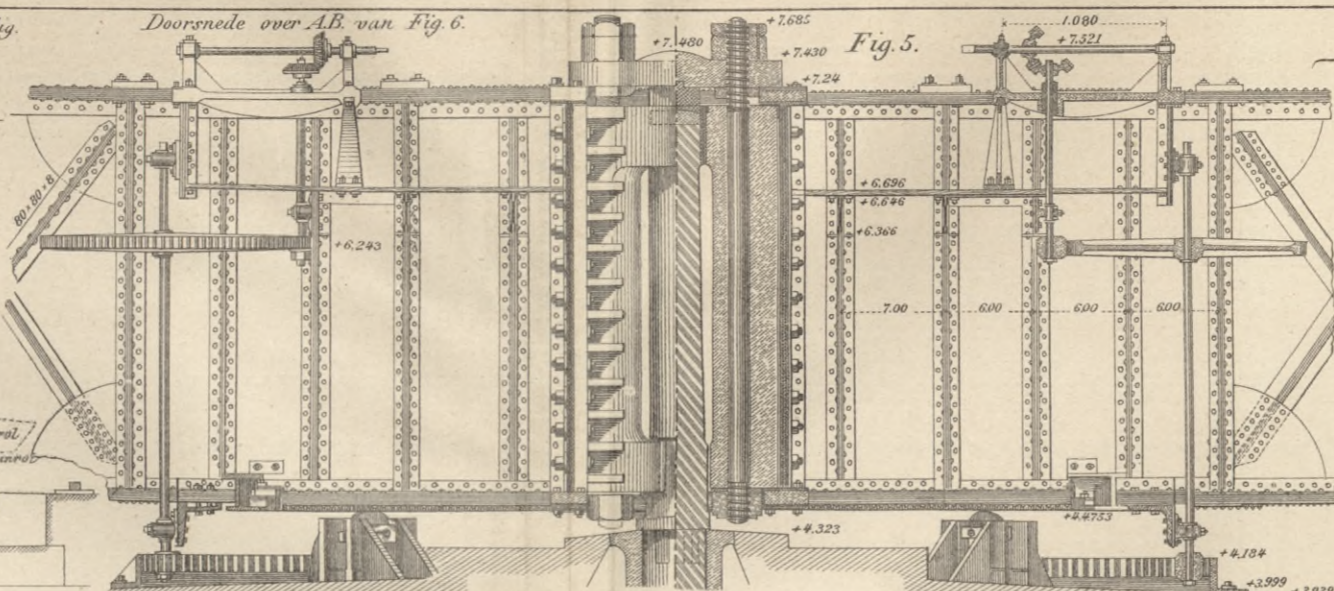
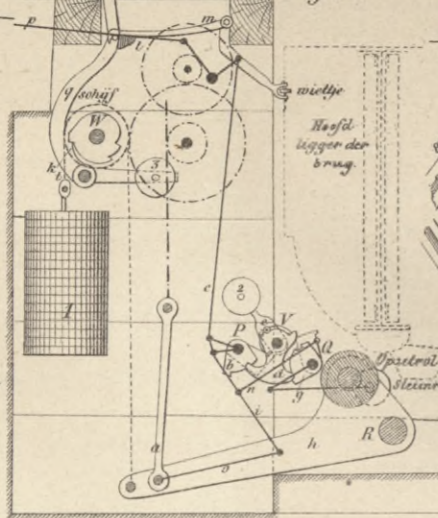
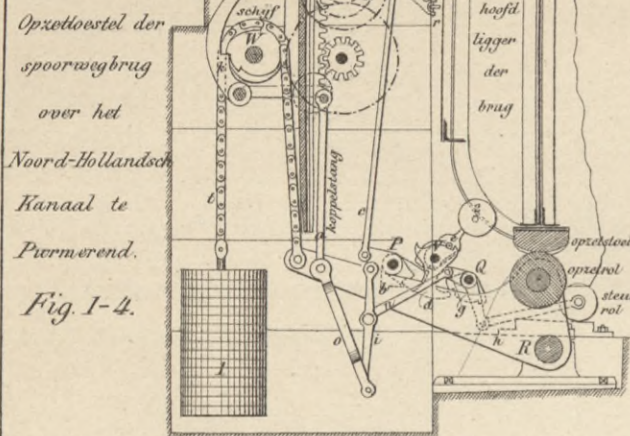

Groote draairug over de Oude Maas te Dordrecht in den spoorweg van Rotterdam naar Dordrecht.

Fig. 5-9.  
Fig. 5-7: 1/50

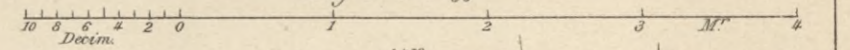

Brug opgezet. Opzetrol 3 m. Mander opzetstoel. Signaal veilig. Fig. 3.

Signaal veilig.

Fig. 3.

hoofdlijger der brug

Fig. 1-3: 1/40.

Fig. 4: 1/20.

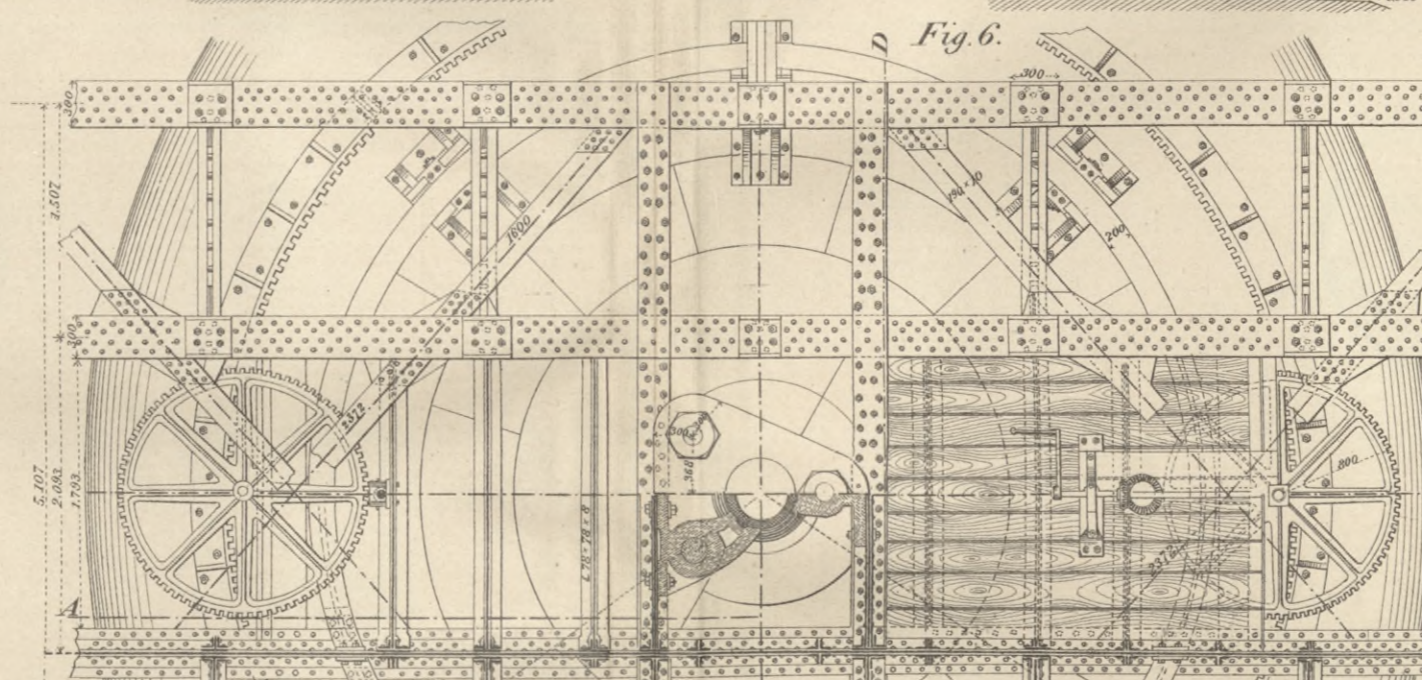
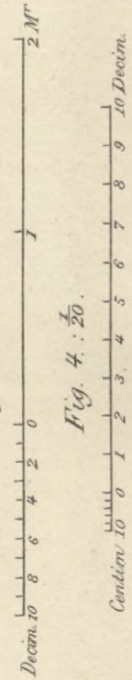
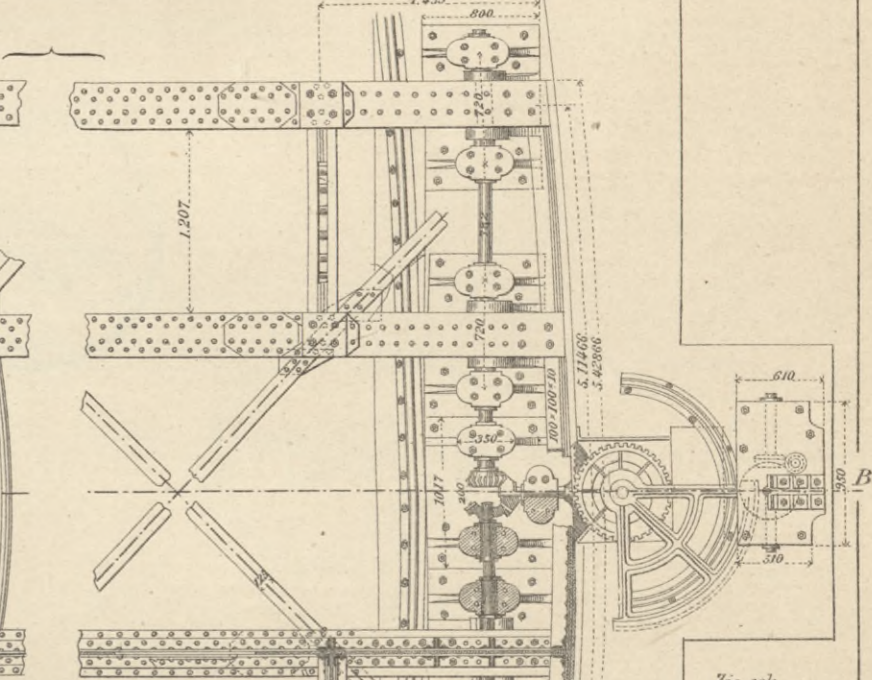
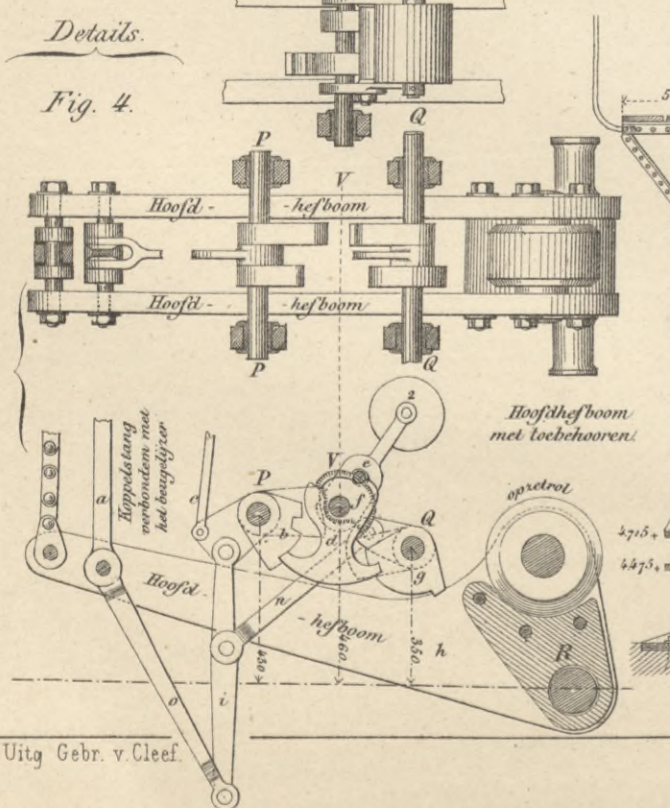

Fig. 6.



Zie ook opzetstoel Pl. 14.

As V met toebehooren. P signaalas. Q as der steunrollen.



Doorsnede over C.D. van Fig. 6. Fig. 7.

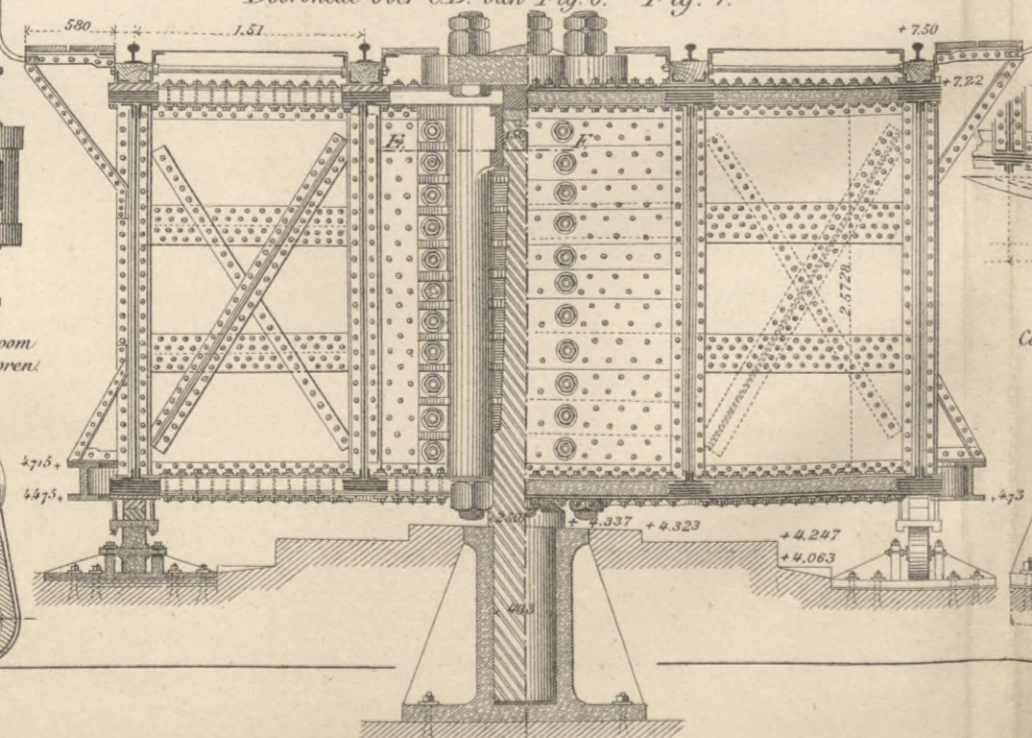

Fig. 8: 1/25.

Fig. 9: 1/500.

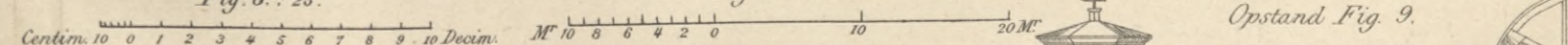
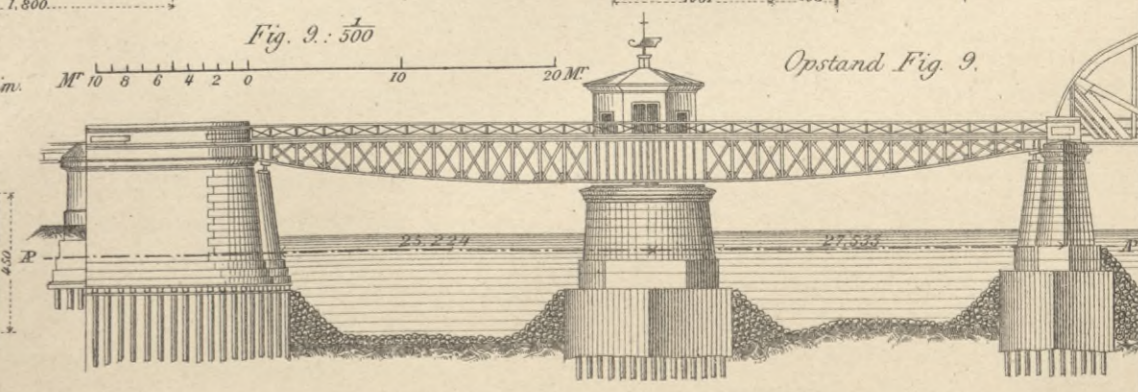

Fig. 8.







Groote draaibrug over de oude Maas bij Dordrecht.

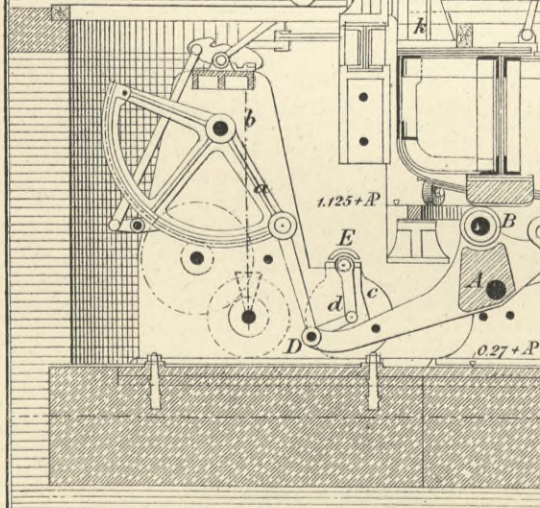
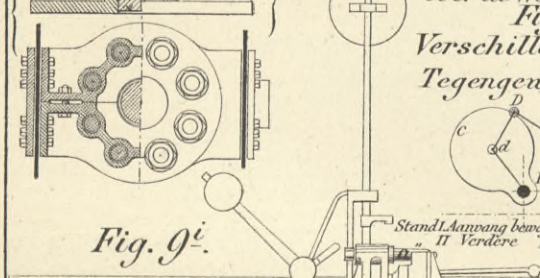
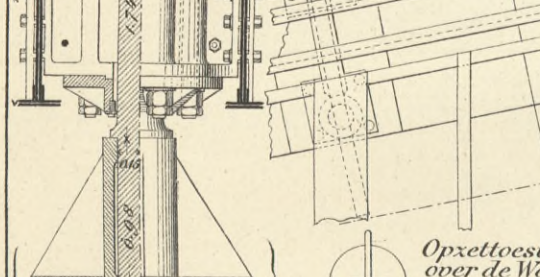
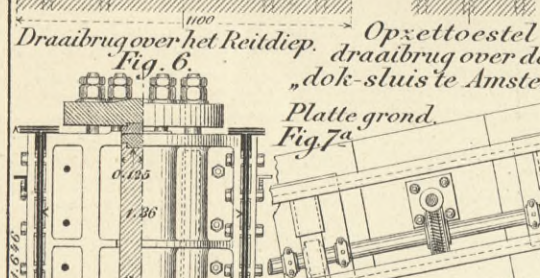
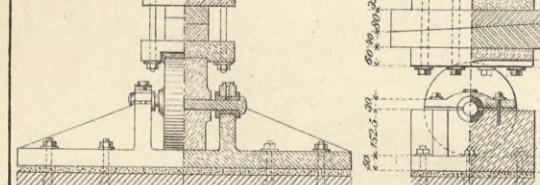
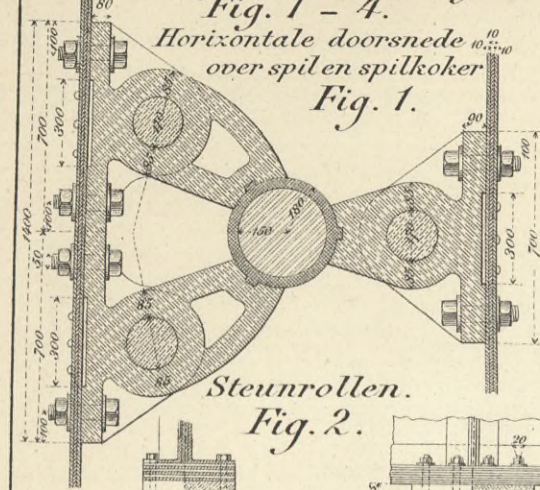

Uitg. de Gebr. v. Cleef.

Draaibrug over het Kanaal door de Oude Arne in den Kleverkerkschen weg op Walcheren. Fig. 5.

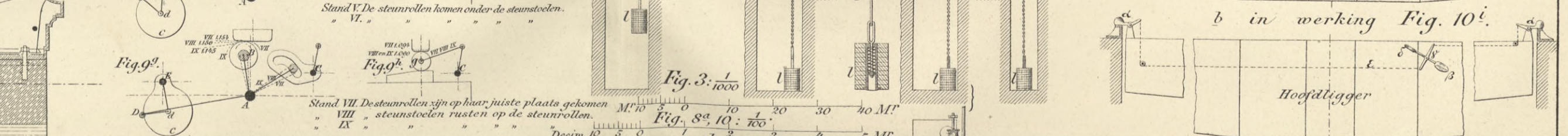
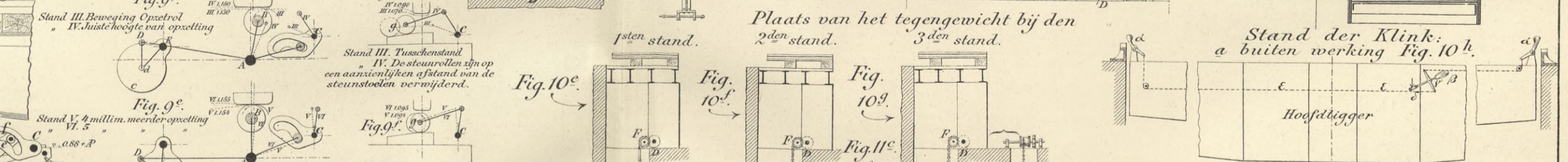
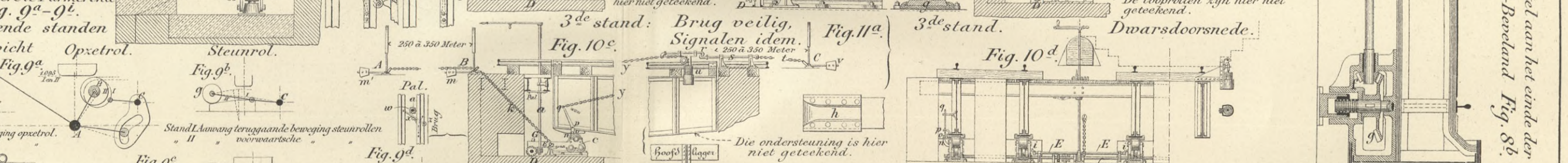
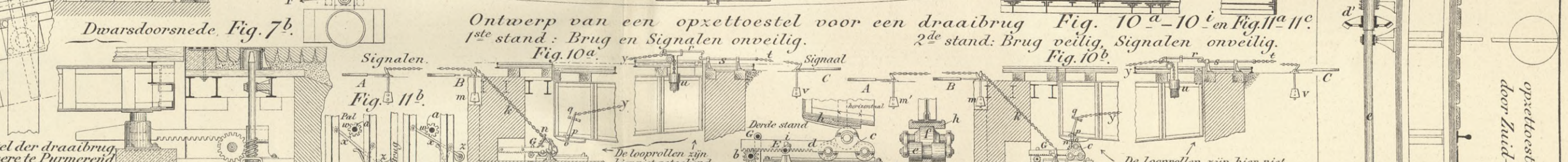
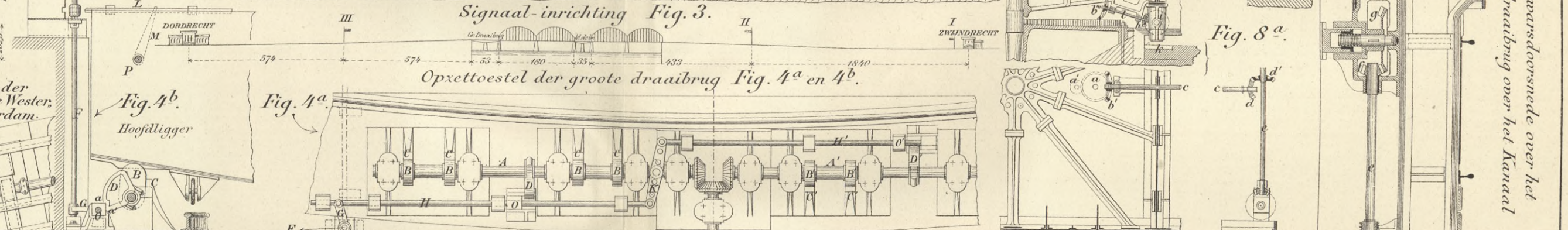
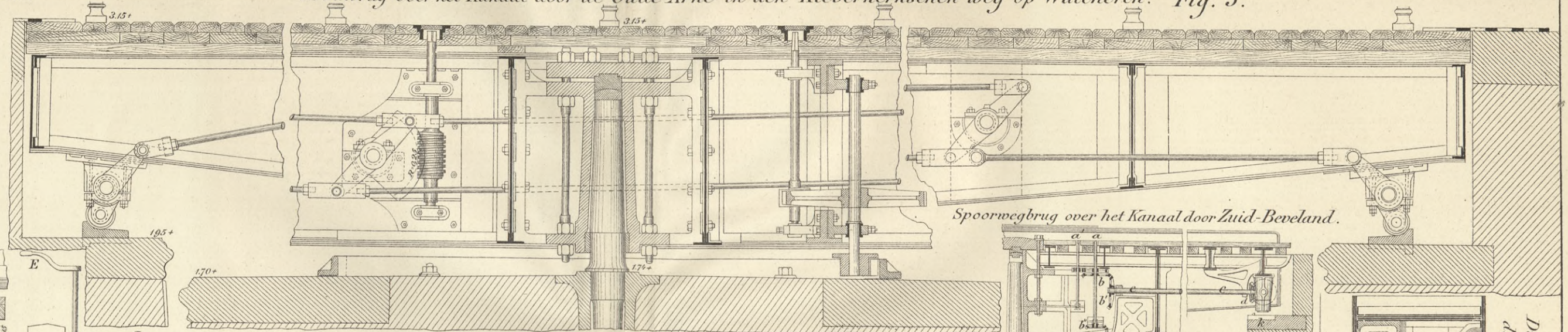

Stand VII. 4 millim. meerder opzetting. VIII. Juiste hoogte van opzetting. IX. Eindbeweging opzettingboom. Spelruimte tusschen opzetrol en opzetstoel = 5 millim. Decim. 10 8 6 4 2 0 1

Tresling & Co Hof-Lith Amst. Centim. 10 0 1 2 3 4 5 6 7 8 9 10 11 12 13 14 15 Decim.







Platte grond.  
Fig. 5.

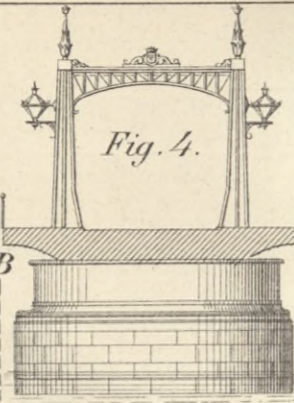
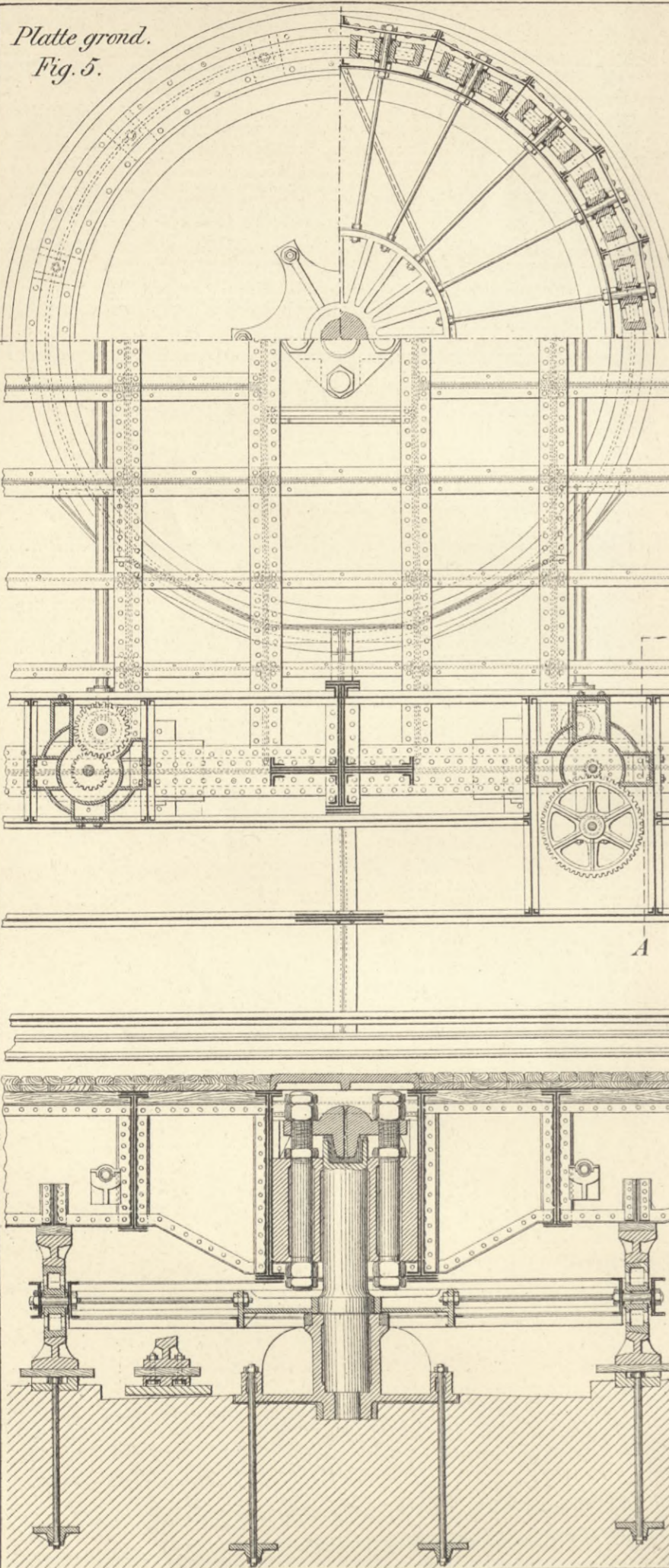

Draaibrug voor gewoon verkeer over de  
Koningshaven op Fijenoord te Rotterdam.  
Aanzicht over de lengte.

Fig. 1.

Aanzicht en doorsnede  
over de breedte.

Fig. 3.

Platte grond. Fig. 2.

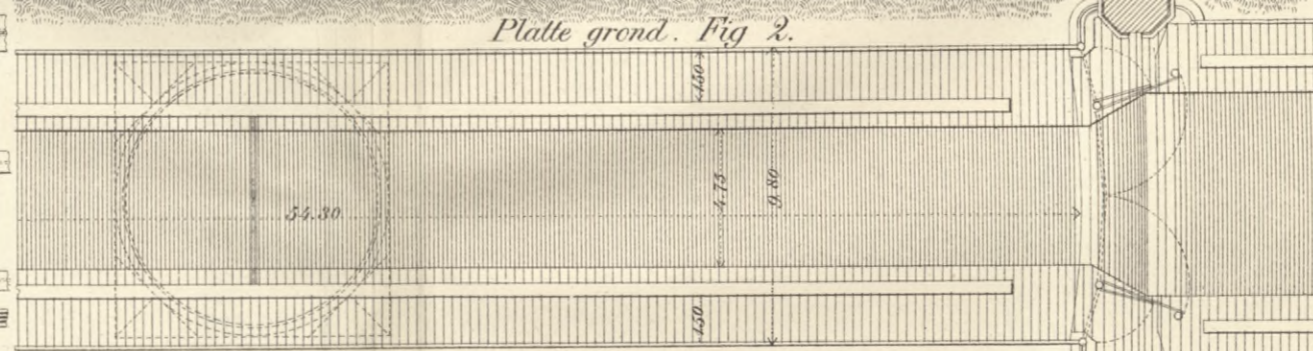

Buiten aanzicht in het midden. Fig. 7.

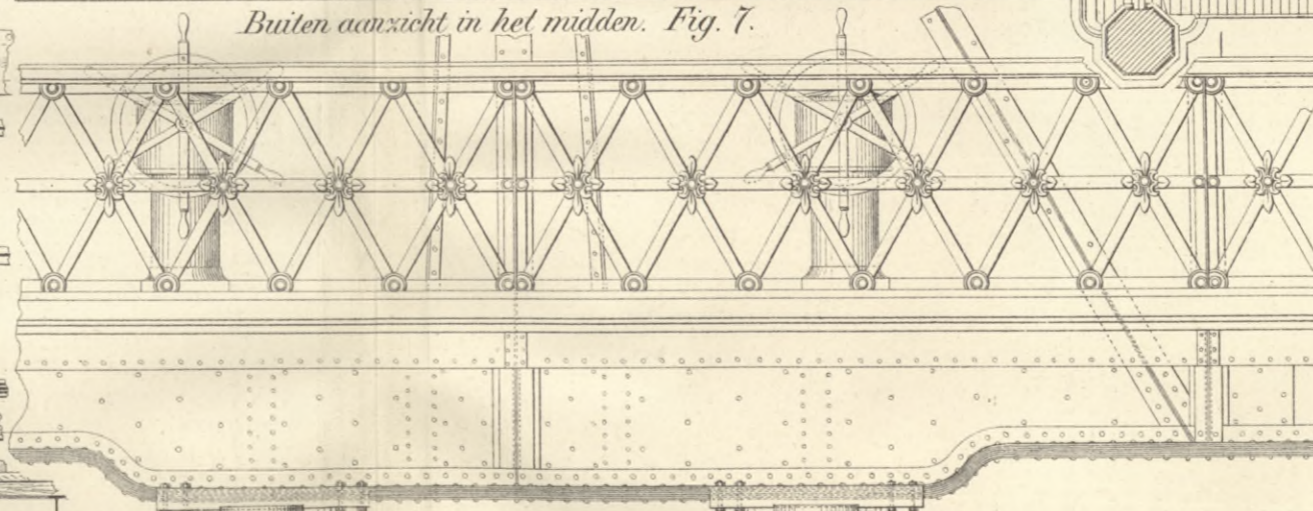

4.48 + P

Doorsnede over de  
lengte in het midden.  
Fig. 6.

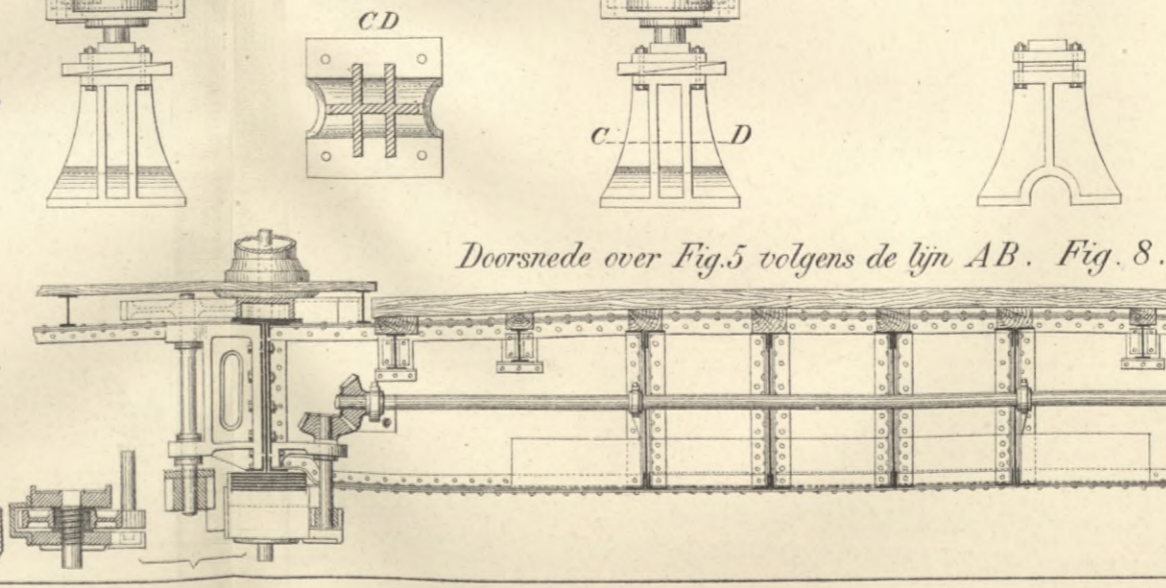
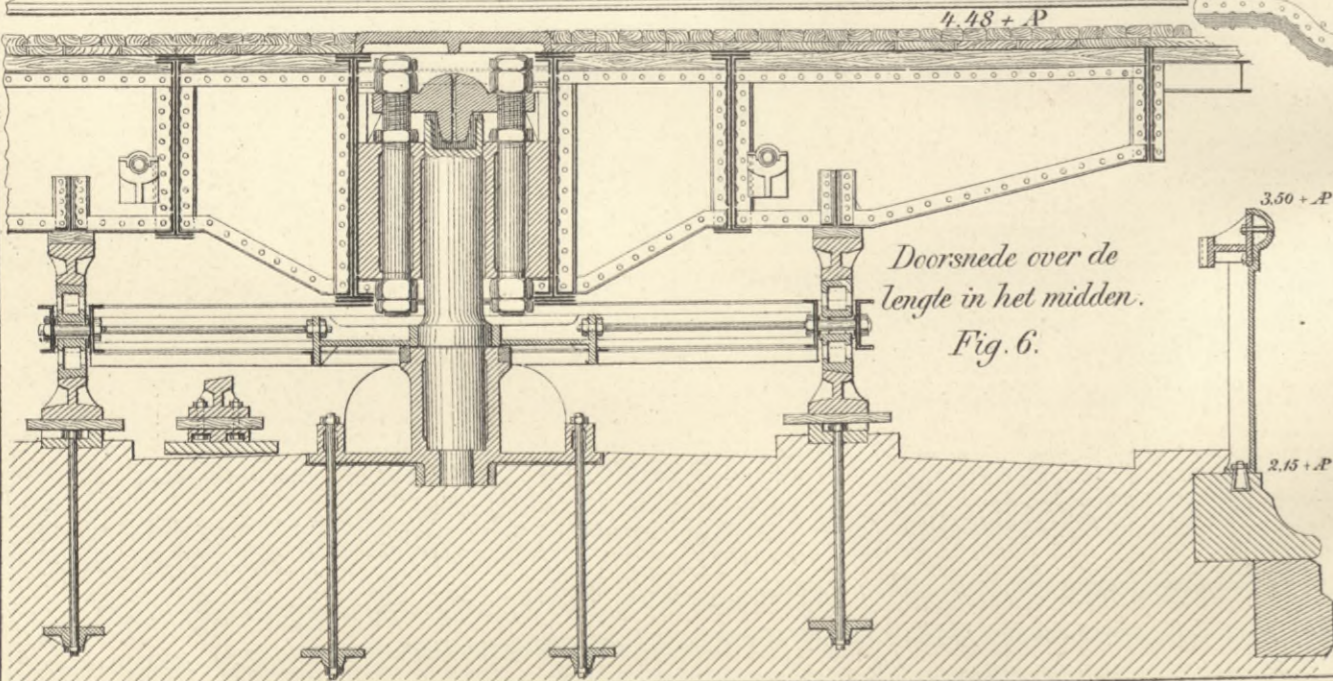

Doorsnede over Fig. 5 volgens de lijn AB. Fig. 8.

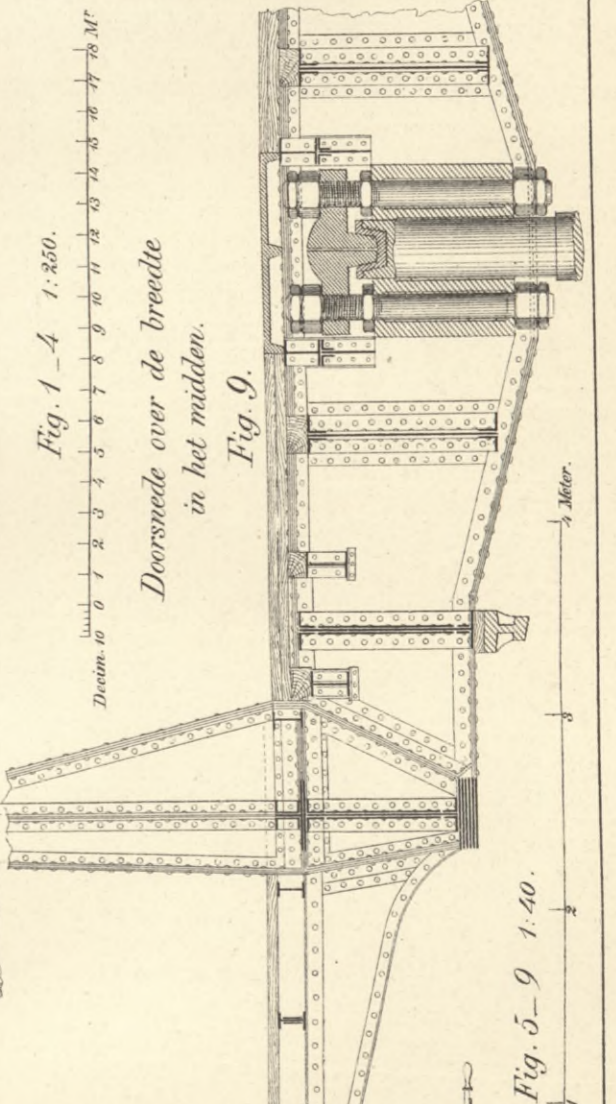

Fig. 1-4 1:350.

Doorsnede over de breedte  
in het midden.

Fig. 9.

Fig. 5-9 1:40.

Decim. 10 0 1 2 3 4 5 6 7 8 9 10 11 12 13 14 15 16 17 18 M<sup>r</sup>





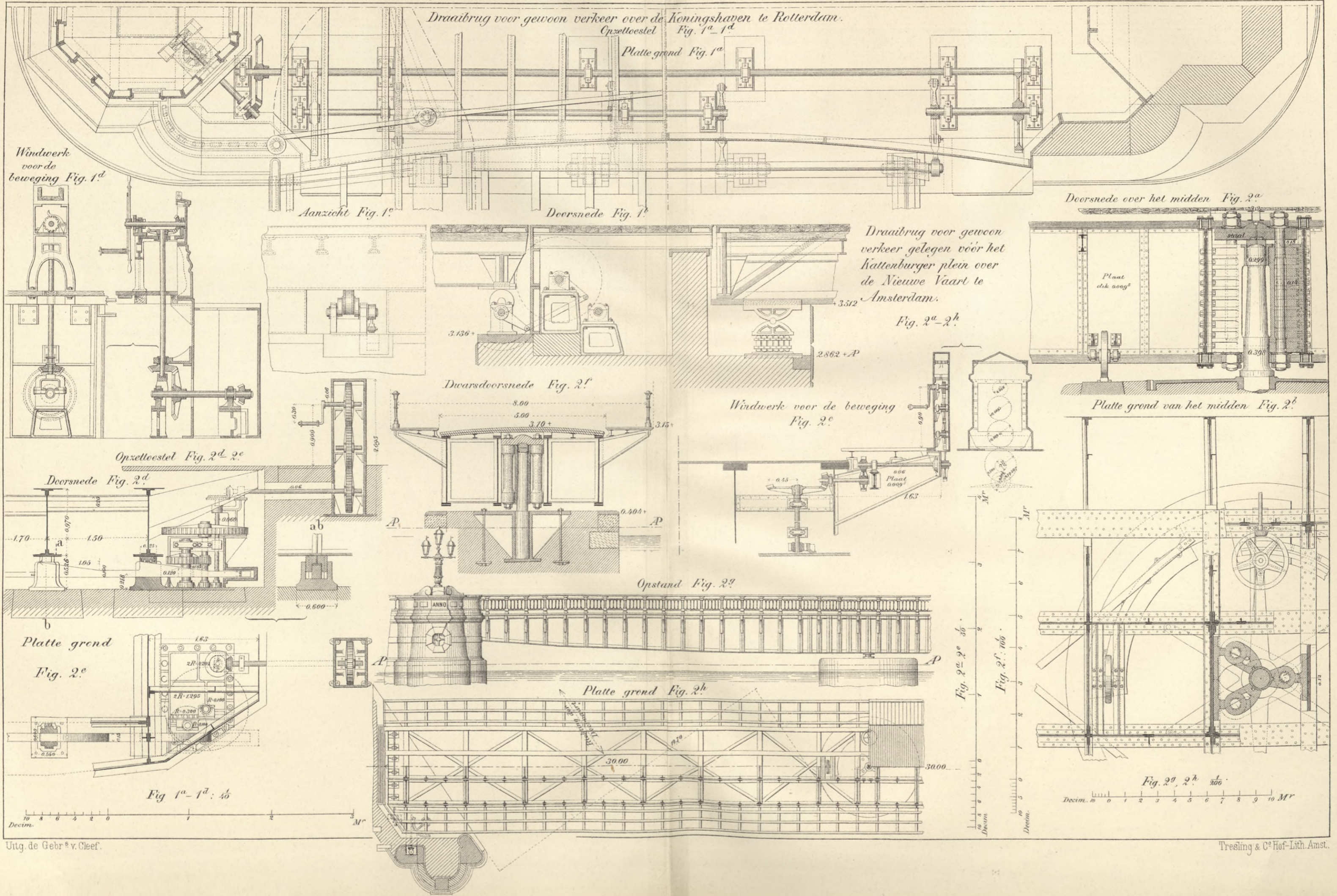





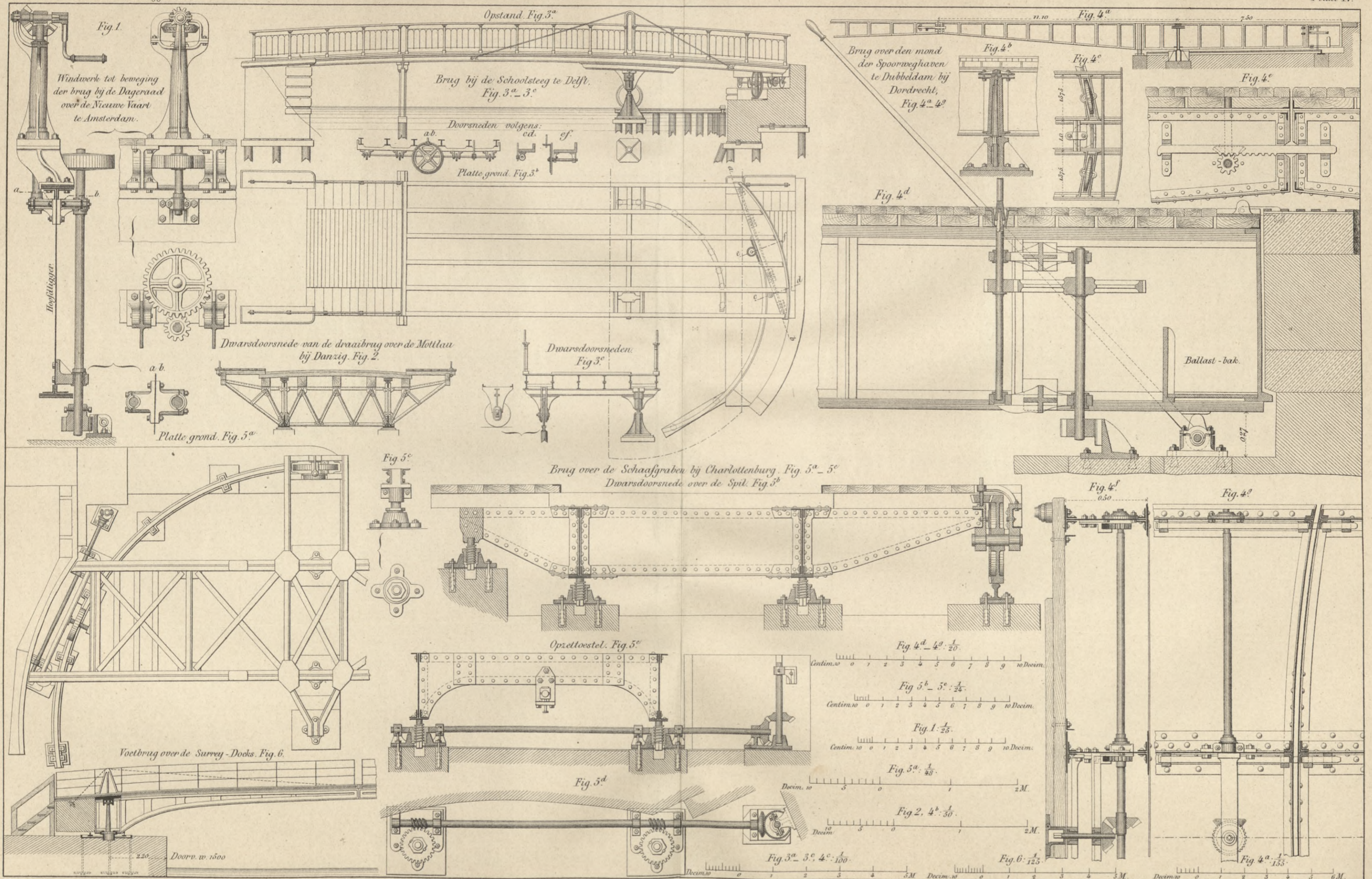







De "Raritan Bay," draaibrug Fig. 1<sup>a</sup> - 1<sup>e</sup>.

Opstand Fig. 1<sup>a</sup>.

Fig. 1<sup>b</sup>.

Opstand Fig. 3<sup>a</sup>.

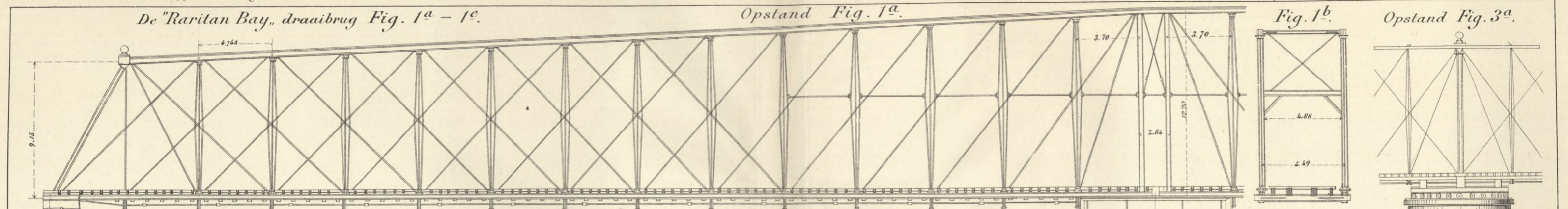

Doorsnede over de lengte in het midden Fig. 1<sup>c</sup>.

Draaibrug over de "Passaic-River," Fig. 2<sup>a</sup> 2<sup>f</sup>.

Draaibrug van de Keystone Bridge C<sup>o</sup> Amerika Fig. 3<sup>a</sup> - 3<sup>e</sup>.

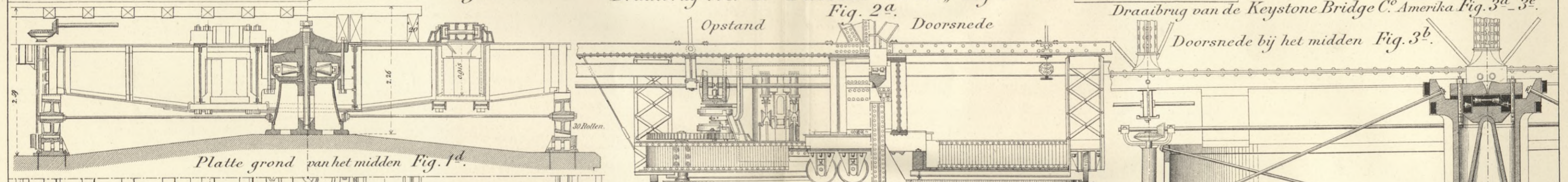

Platte grond van het midden Fig. 1<sup>d</sup>.

Platte grond van het midden Fig. 2<sup>b</sup>.

Platte grond van het midden Fig. 3<sup>c</sup>.

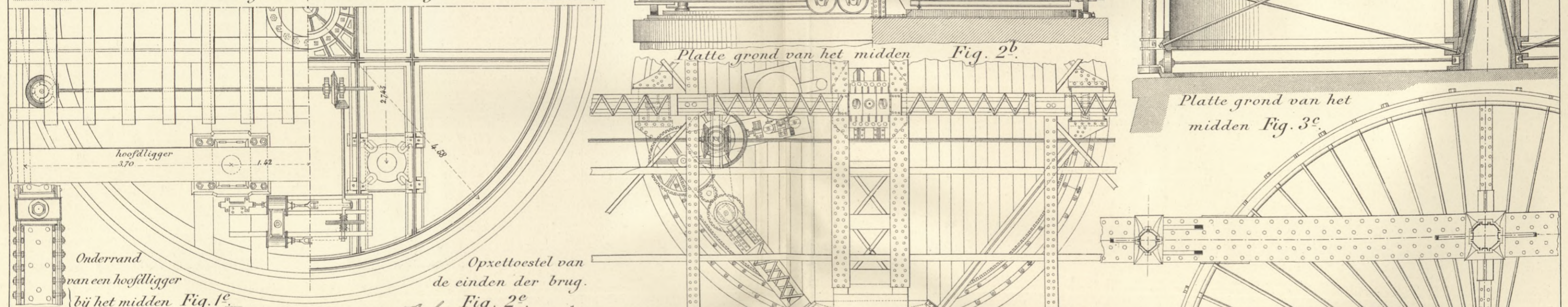

Onderrand van een hoofdligger bij het midden Fig. 1<sup>e</sup>.

Opzettoestel van de einden der brug Fig. 2<sup>e</sup>.

Dwarsdoorsnede Fig. 2<sup>e</sup>.

Opzettoestel van de einden der brug Fig. 3<sup>d</sup>.

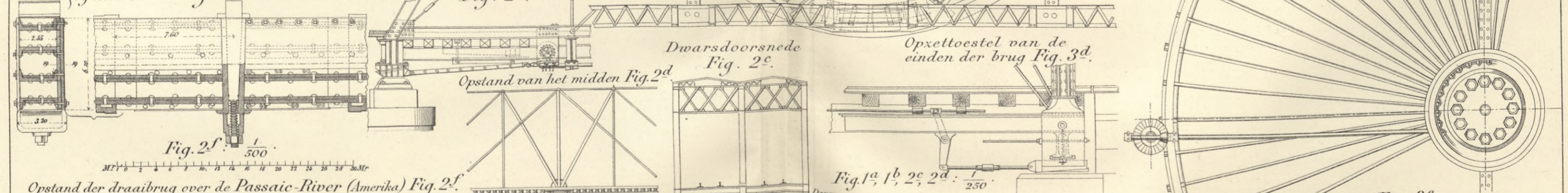

Fig. 2<sup>f</sup> : 1/500

Fig. 1<sup>a</sup>, 1<sup>b</sup>, 2<sup>e</sup>, 2<sup>d</sup> : 1/250

Fig. 3<sup>a</sup> : 1/300

Fig. 3<sup>b</sup>, 3<sup>c</sup>, 3<sup>d</sup> : 1/53

Opstand Fig. 3<sup>e</sup>.

Fig. 1<sup>e</sup> : 1/25

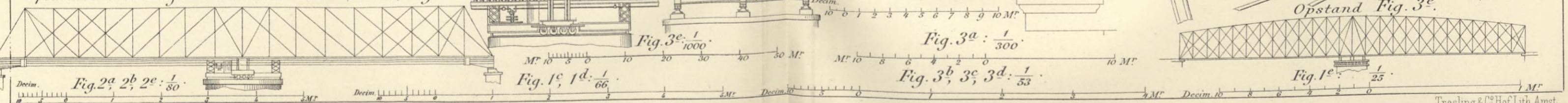













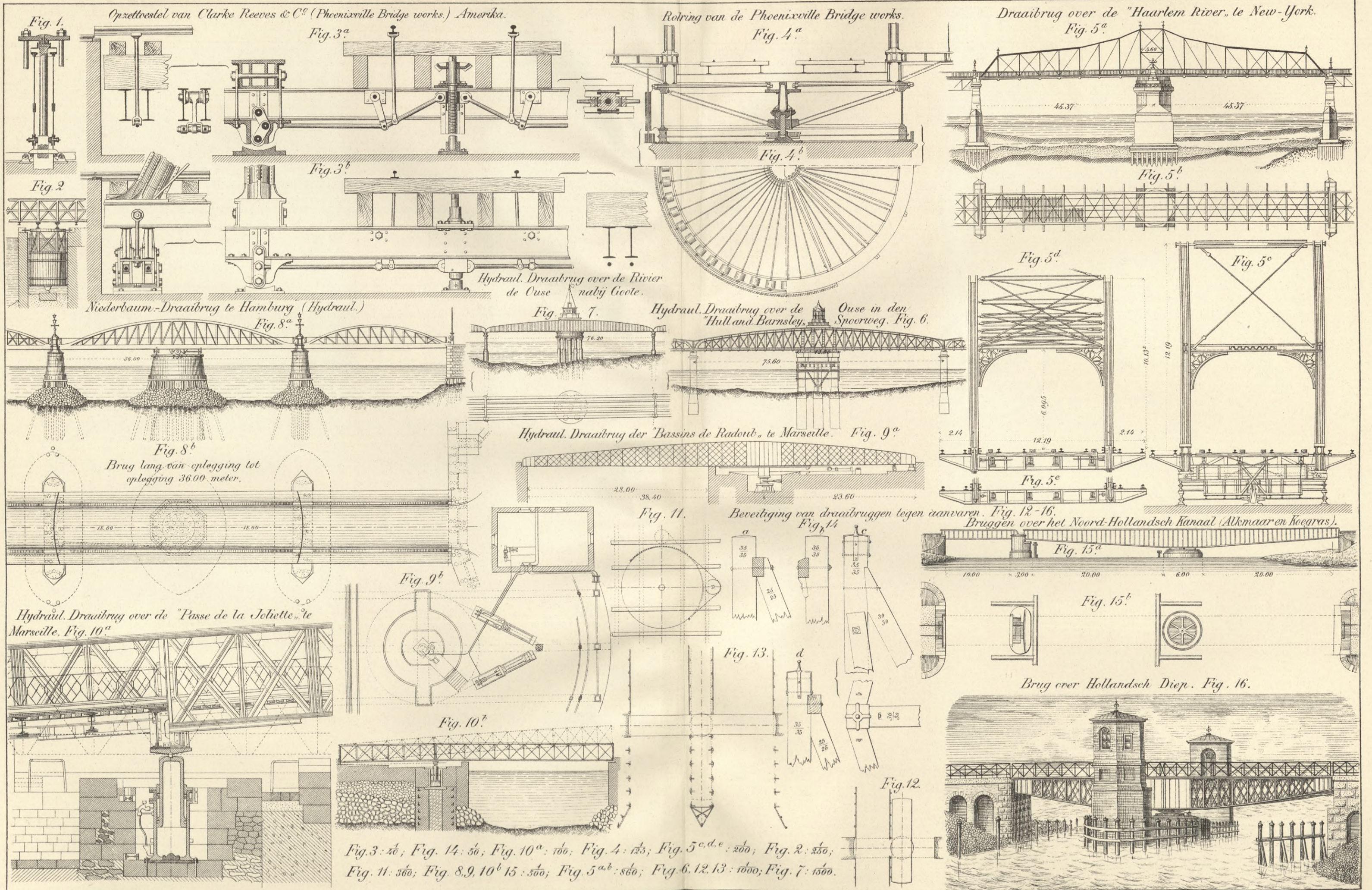
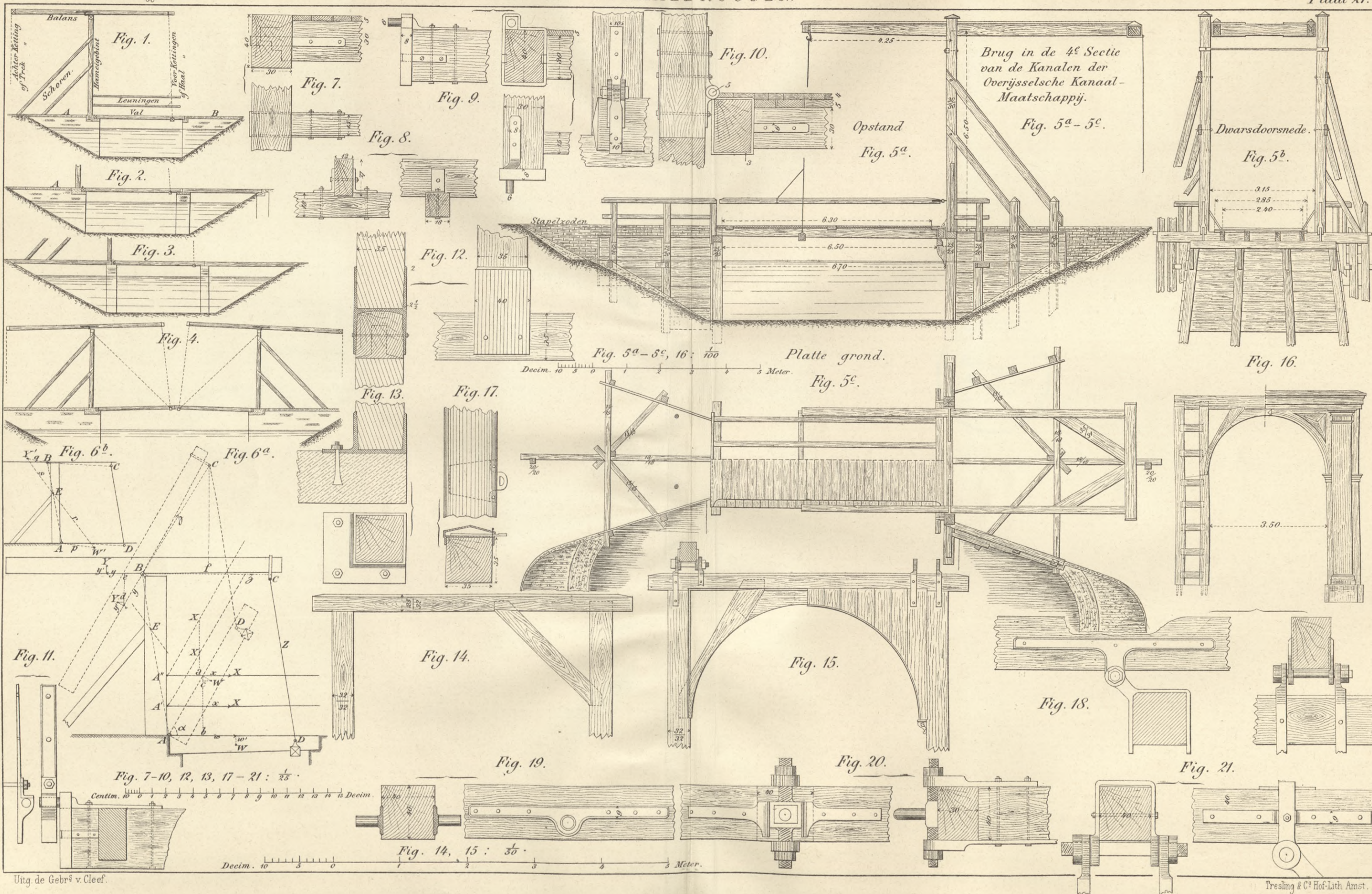

Fig. 3: 1/60; Fig. 14: 1/50; Fig. 10<sup>a</sup>: 1/100; Fig. 4: 1/125; Fig. 5<sup>c,d,e</sup>: 1/200; Fig. 2: 1/250; Fig. 11: 1/300; Fig. 8, 9, 10<sup>b</sup>, 15: 1/500; Fig. 5<sup>a,b</sup>: 1/800; Fig. 6, 12, 13: 1/1000; Fig. 7: 1/1500.











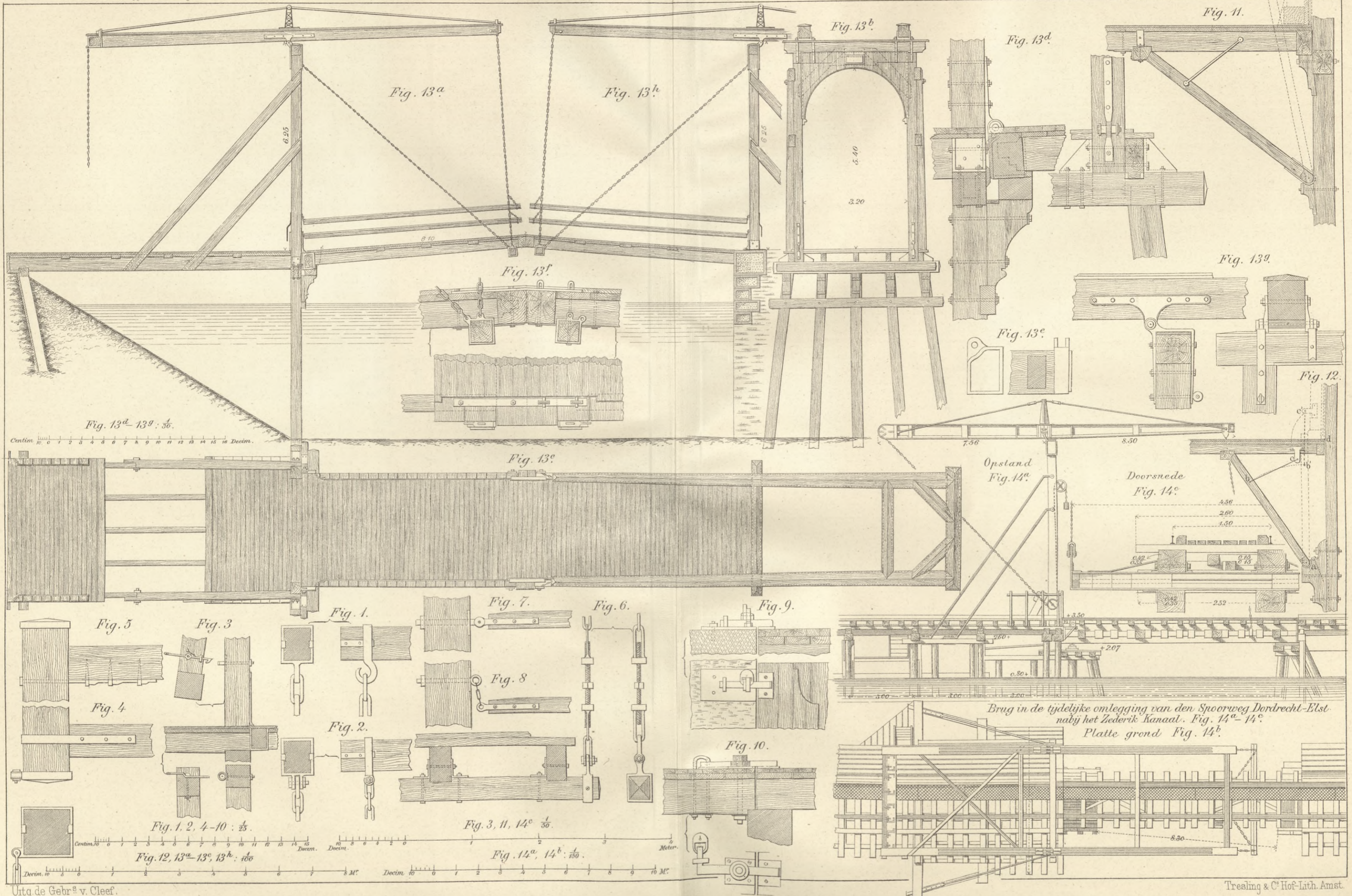







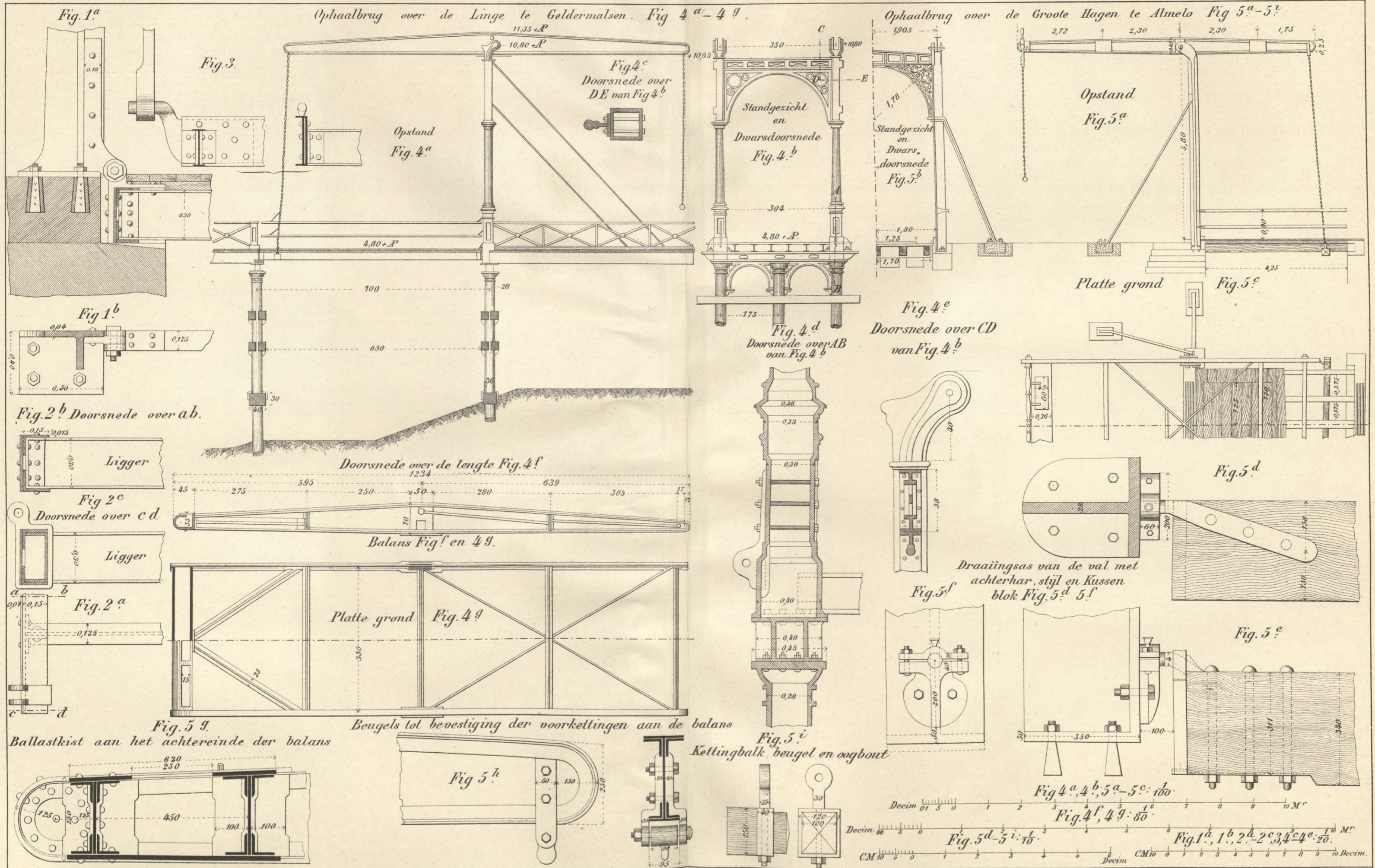





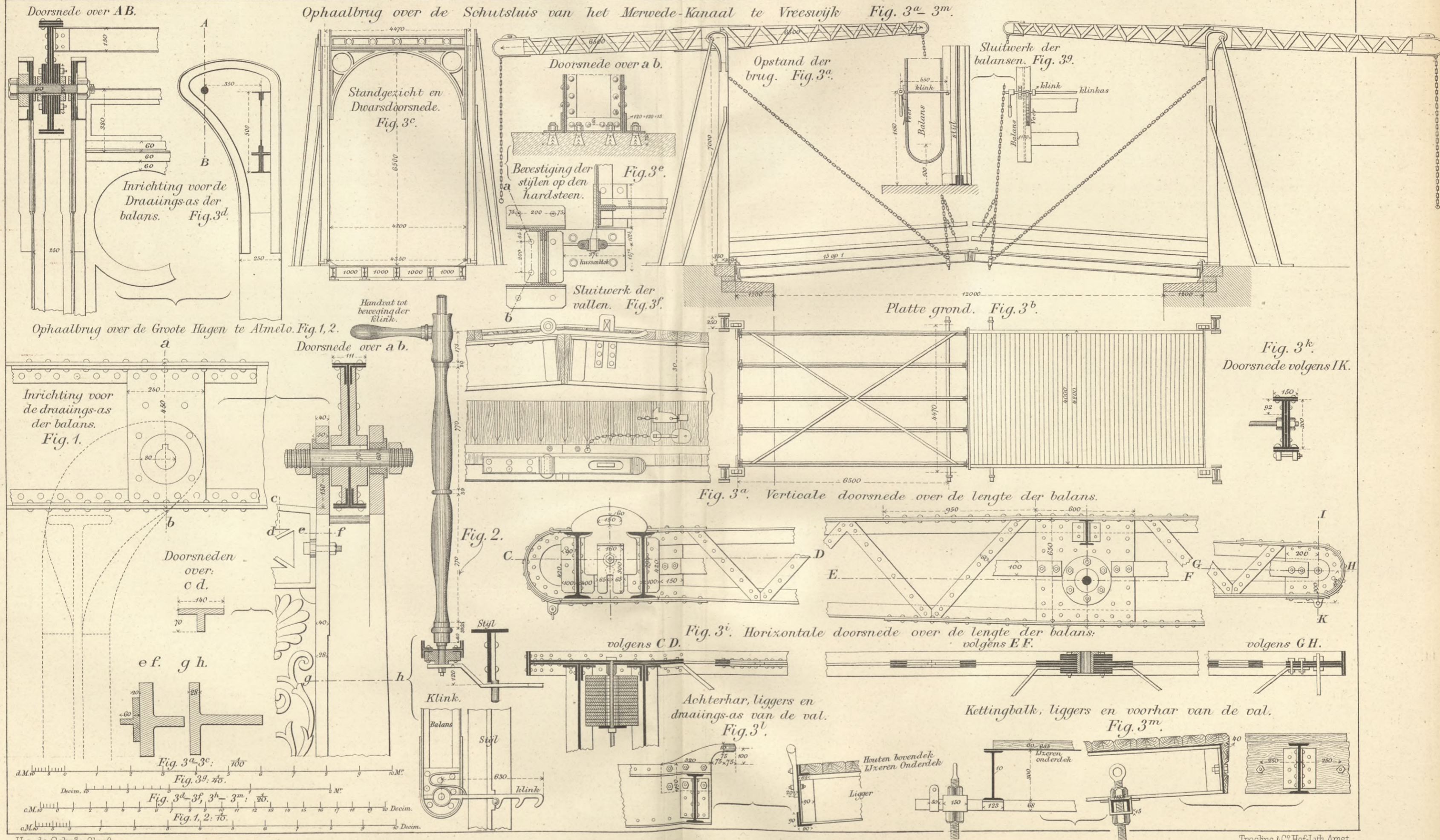





Ophaalbrug over de rivier de Vecht te Nederhorst den Berg Fig. 1-10.

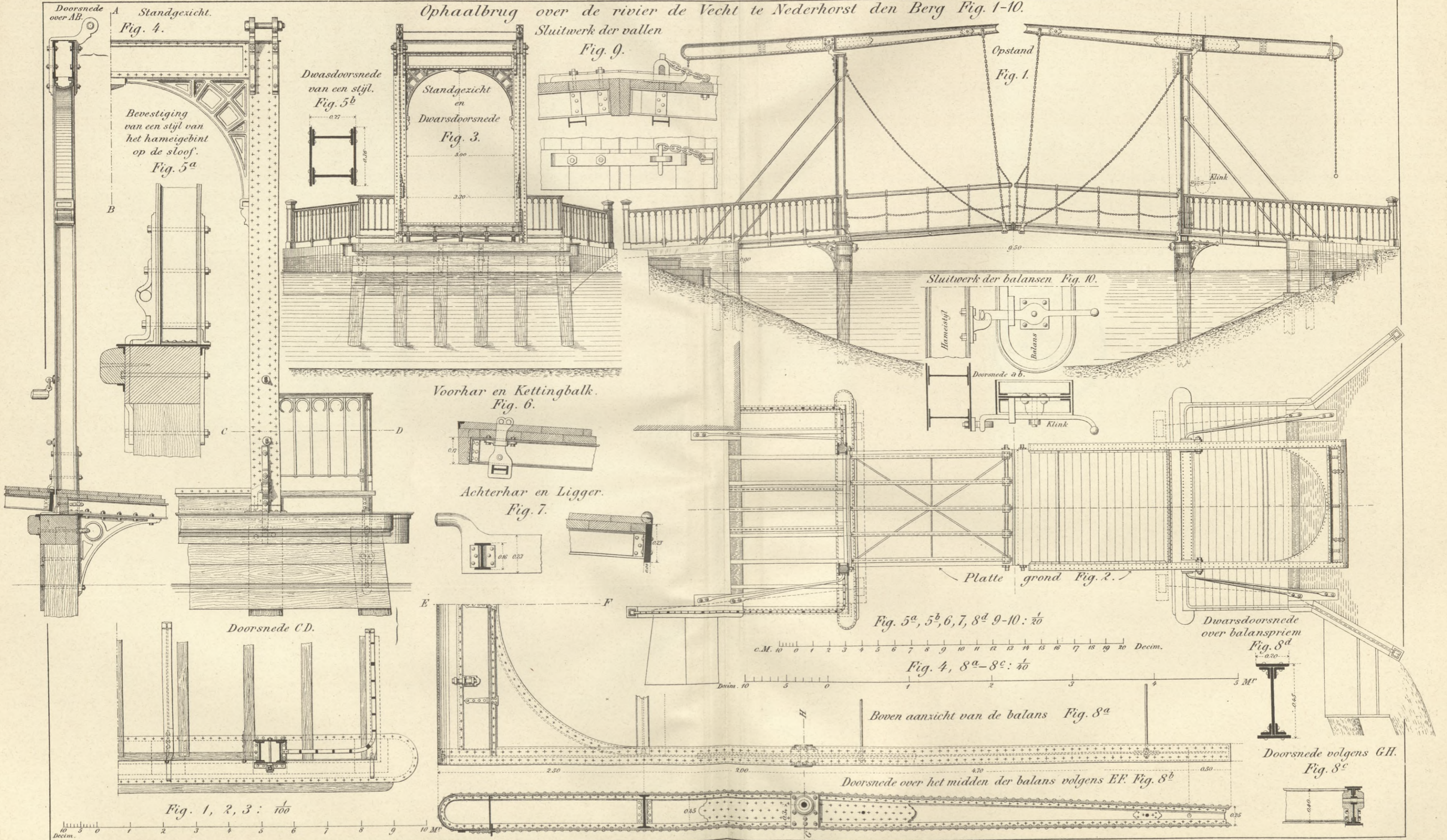







Ophaalbrug te Maastricht over de bassinsluis van het Kanaal van Luik naar Maastricht - Fig. 1<sup>a</sup>-1<sup>m</sup>

Ophaalbrug buiten de Oostpoort te Delft - Fig. 2<sup>a</sup>-2<sup>e</sup>

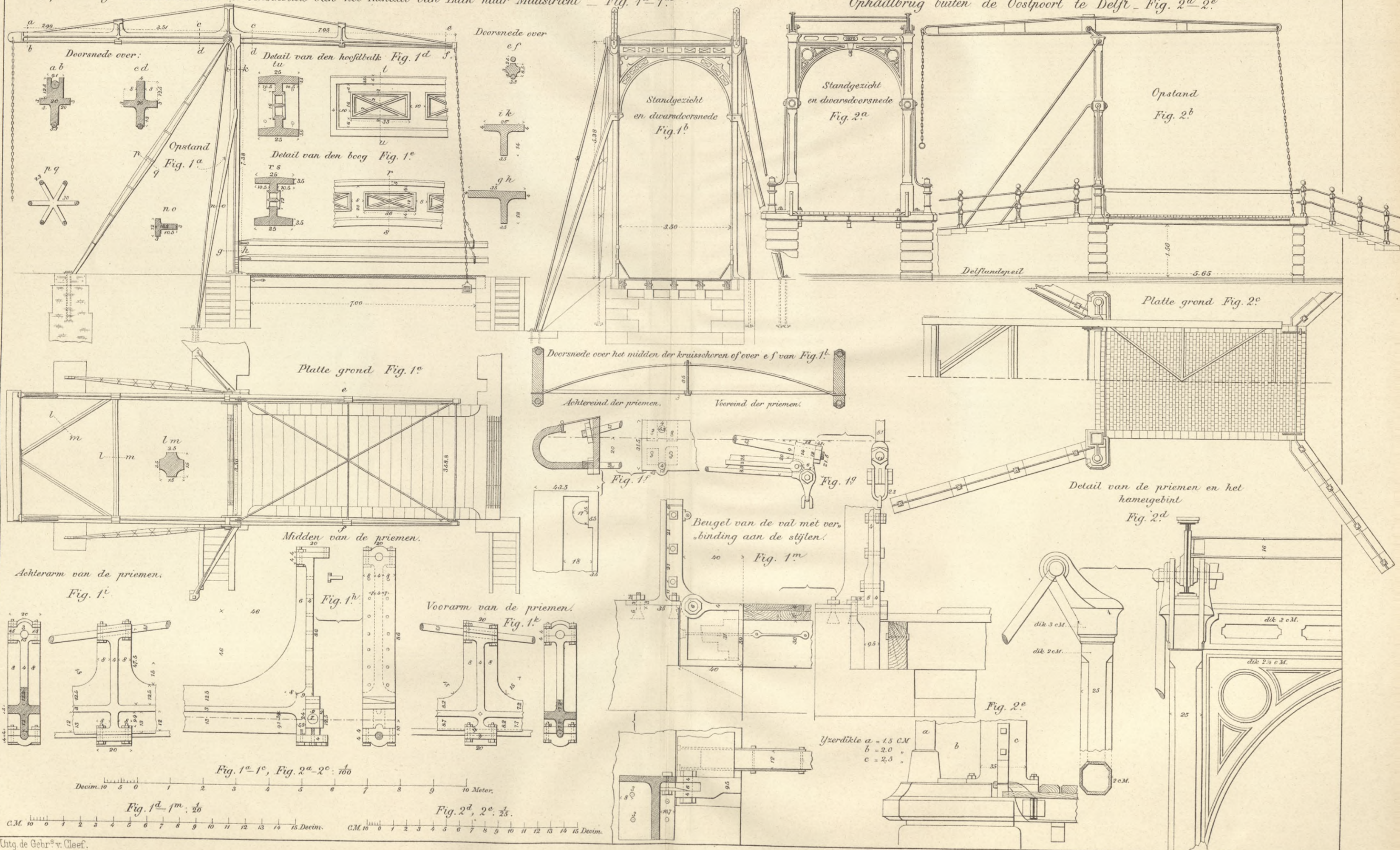

Fig. 1<sup>a</sup>-1<sup>c</sup>, Fig. 2<sup>a</sup>-2<sup>c</sup>: 1/100

Fig. 1<sup>d</sup>-1<sup>m</sup>: 1/20

Fig. 2<sup>d</sup>, 2<sup>e</sup>: 1/25





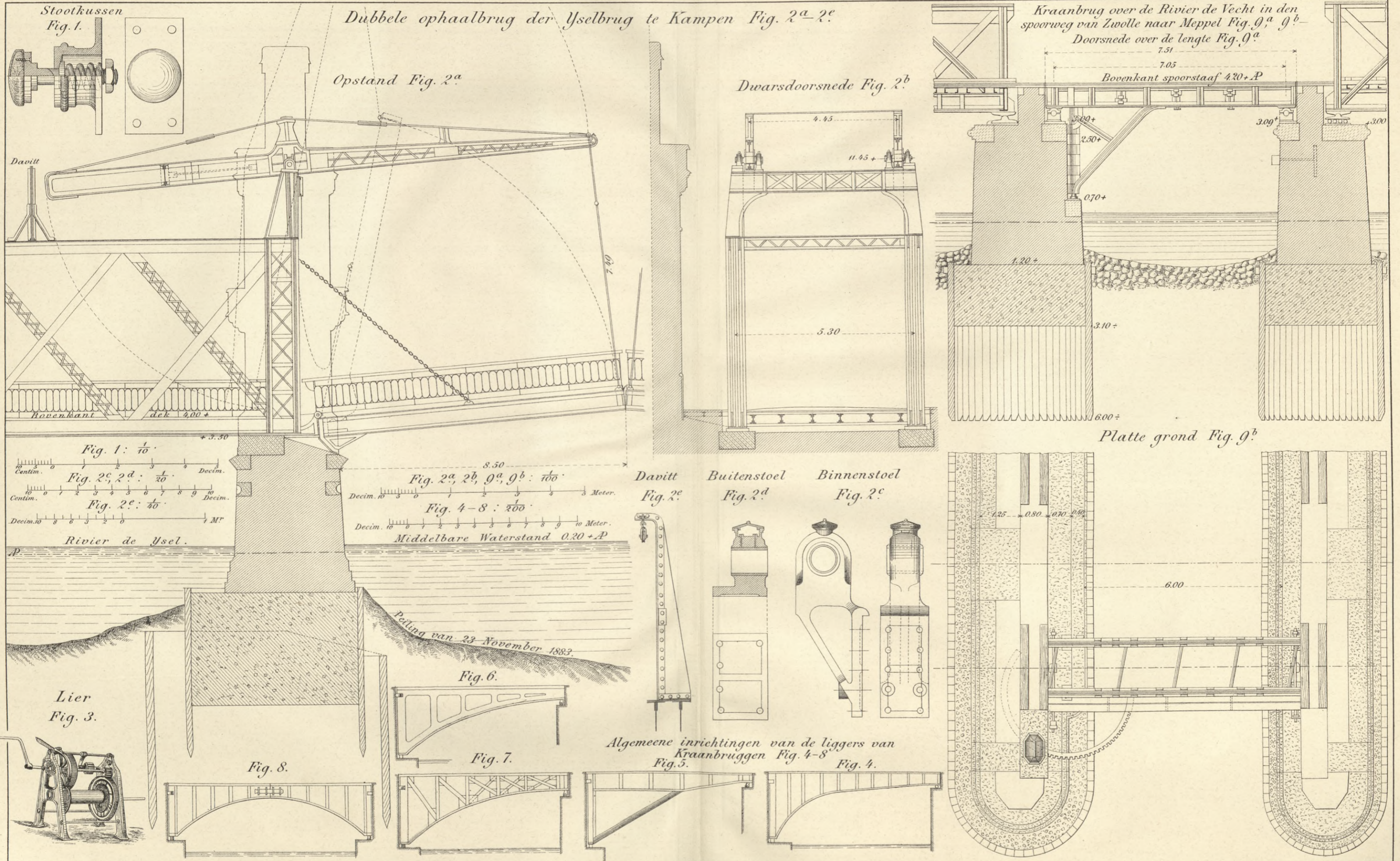







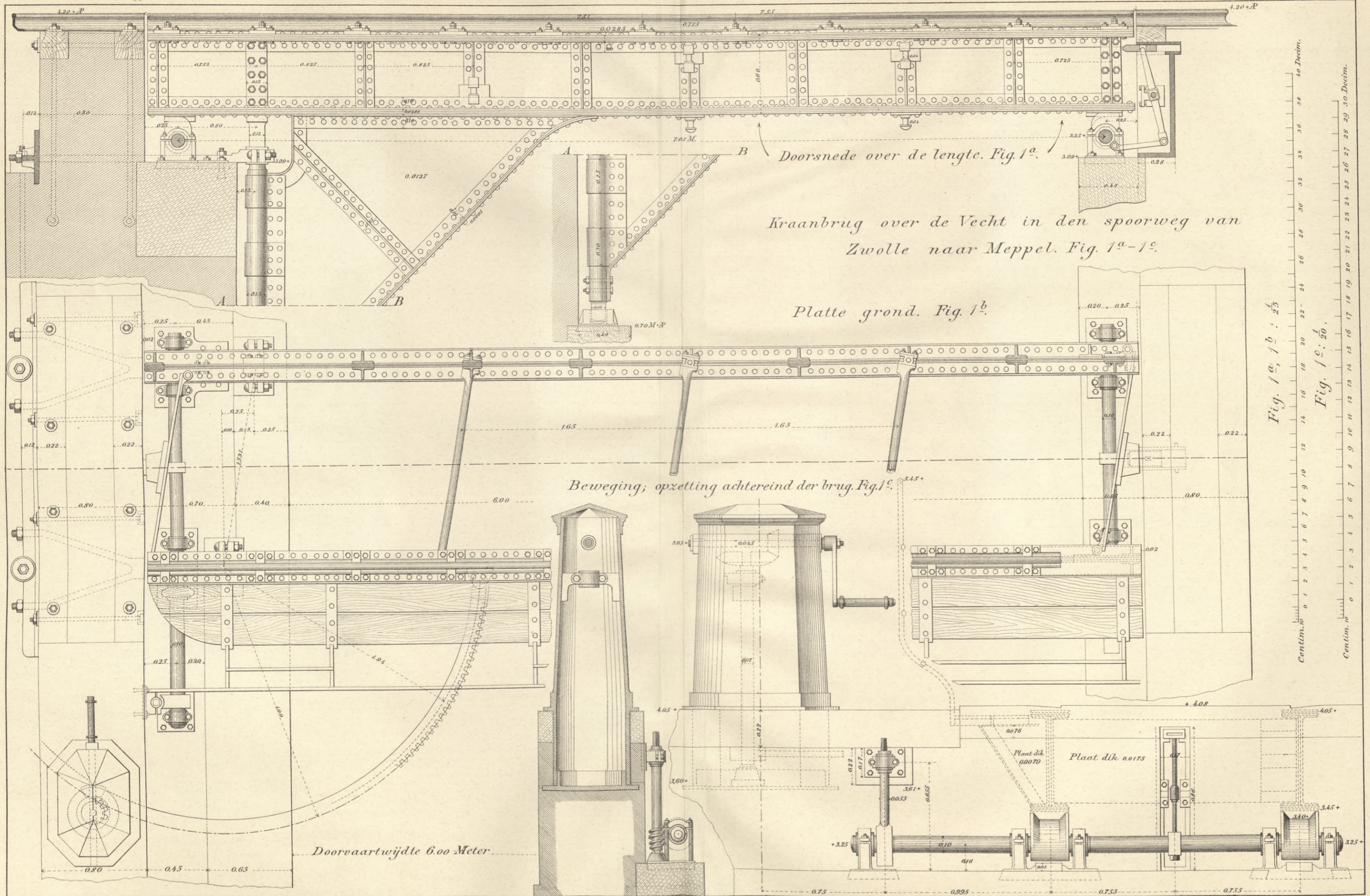

Doorsnede over de lengte. Fig. 1<sup>a</sup>.  
 Kraanbrug over de Vecht in den spoorweg van  
 Zwolle naar Meppel. Fig. 1<sup>a</sup>-1<sup>c</sup>.

Platte grond. Fig. 1<sup>b</sup>.

Beweging; opzetting achtereind der brug. Fig. 1<sup>c</sup>.

Fig. 1<sup>a</sup>, 1<sup>b</sup> : 25  
 Fig. 1<sup>c</sup> : 20.  
 Centim. 0 1 2 3 4 5 6 7 8 9 10 11 12 13 14 15 16 17 18 19 20 21 22 23 24 25 26 27 28 29 30 Decim.  
 Centim. 0 1 2 3 4 5 6 7 8 9 10 11 12 13 14 15 16 17 18 19 20 21 22 23 24 25 26 27 28 29 30 Decim.











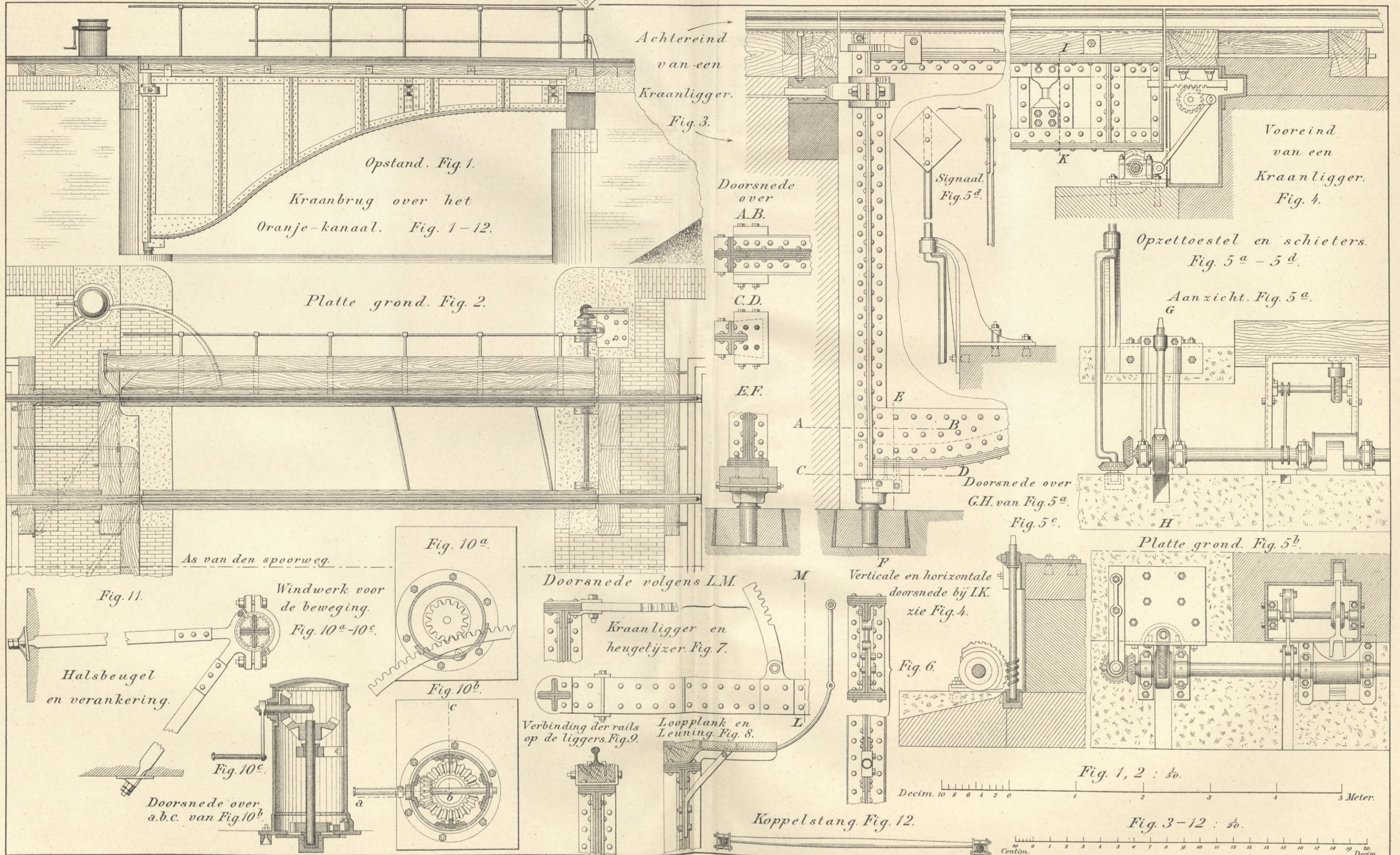







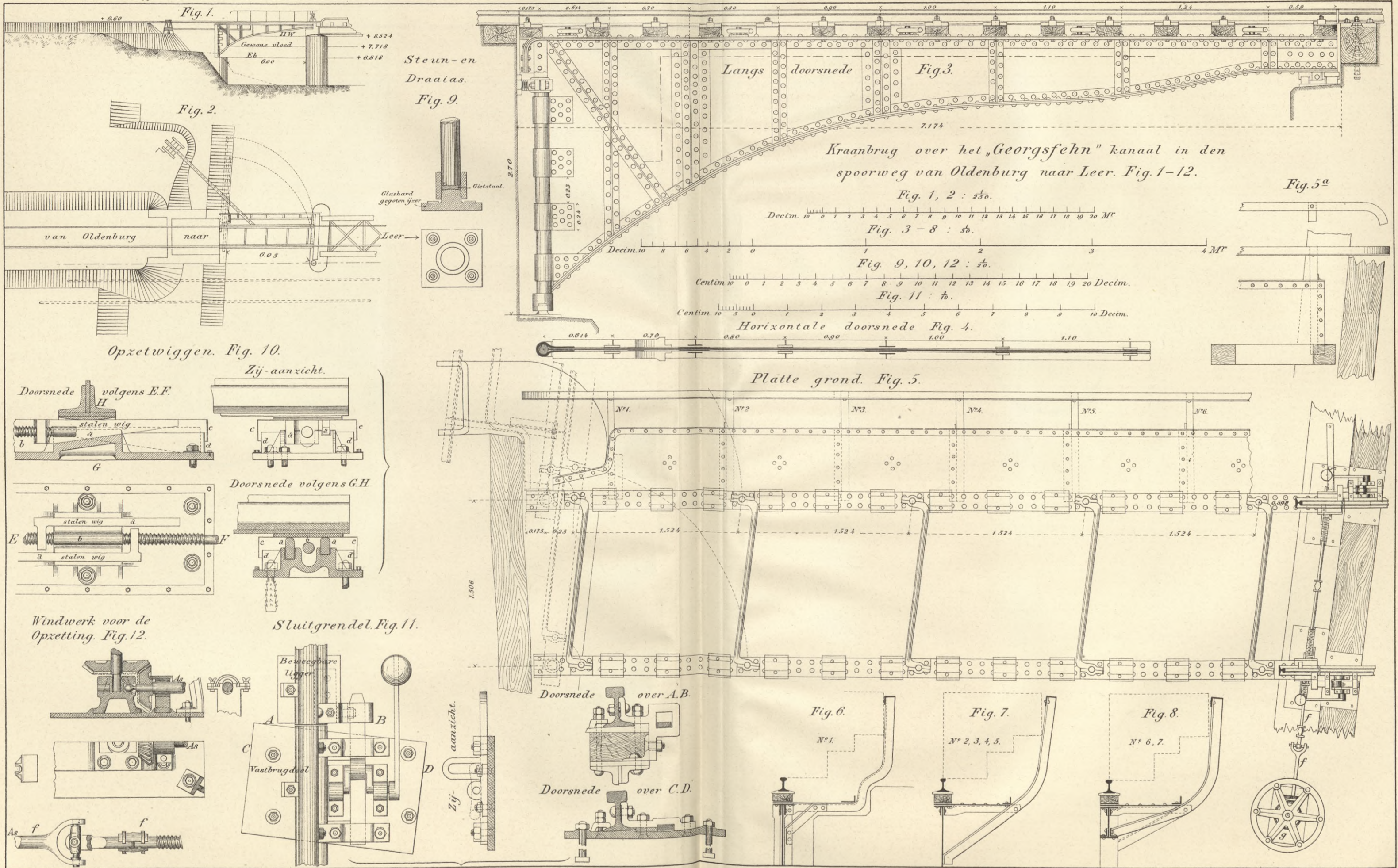





Algemeene inrichtingen van Rolbruggen. Fig. 1-8.

Vroeger bestaande houten Rolbrug nabij Haarlem over de Ringvaart der Haarlemmermeer Fig. 9<sup>a</sup>-9<sup>d</sup> Opstand Fig. 9<sup>a</sup>

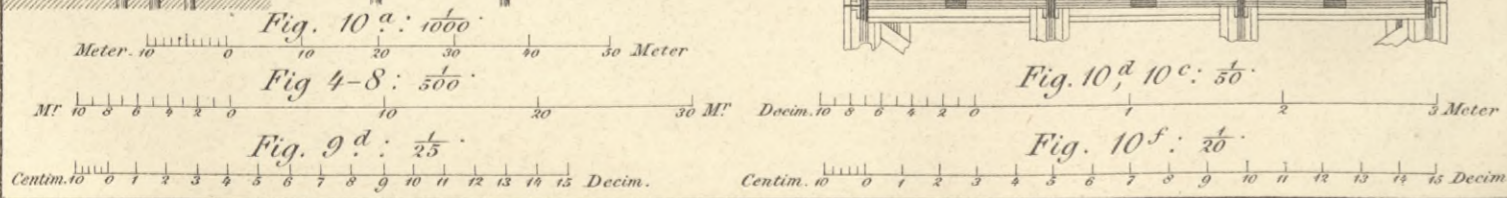
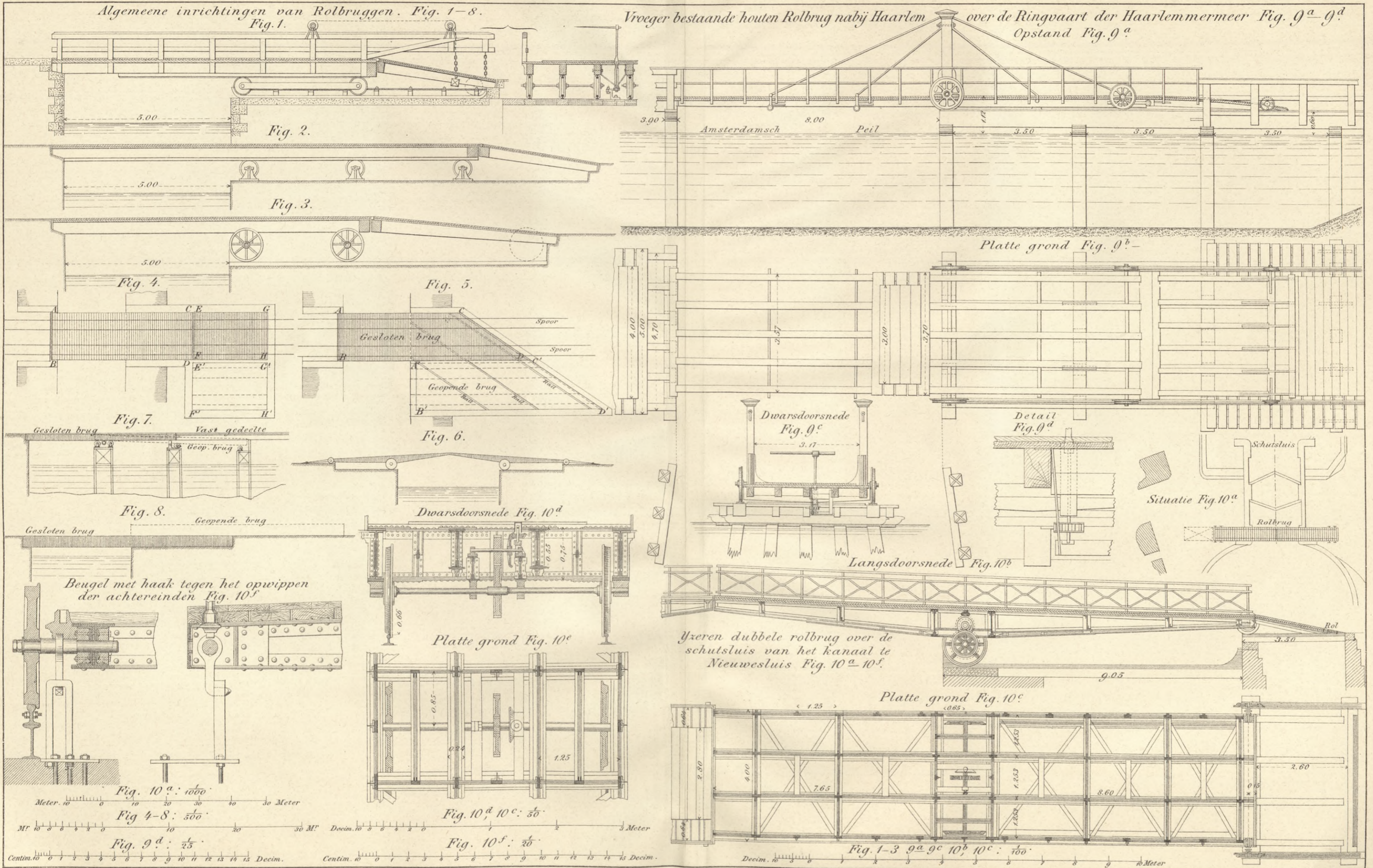





Aanzicht der brug voor gewoon verkeer over de Donge te Geertruidenberg. Fig. 1.

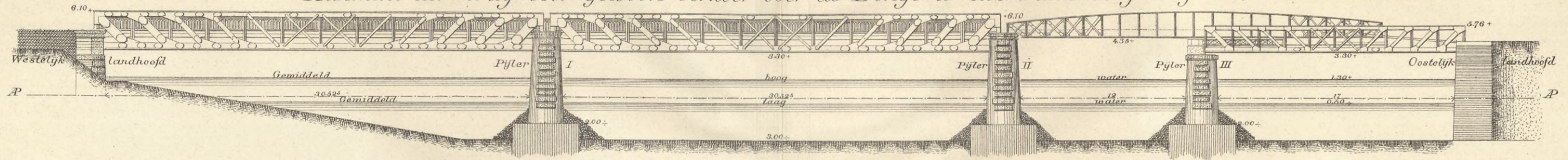

Aanzicht der rolbrug. Fig. 2.

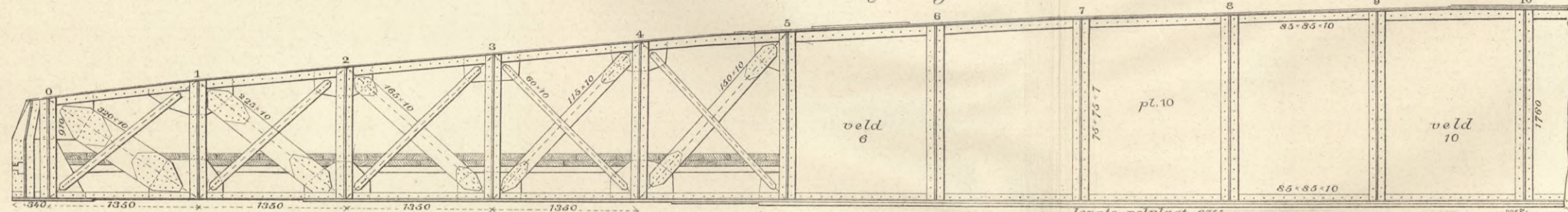

Platte grond en horizontale doorsnede der rolbrug Fig. 4.

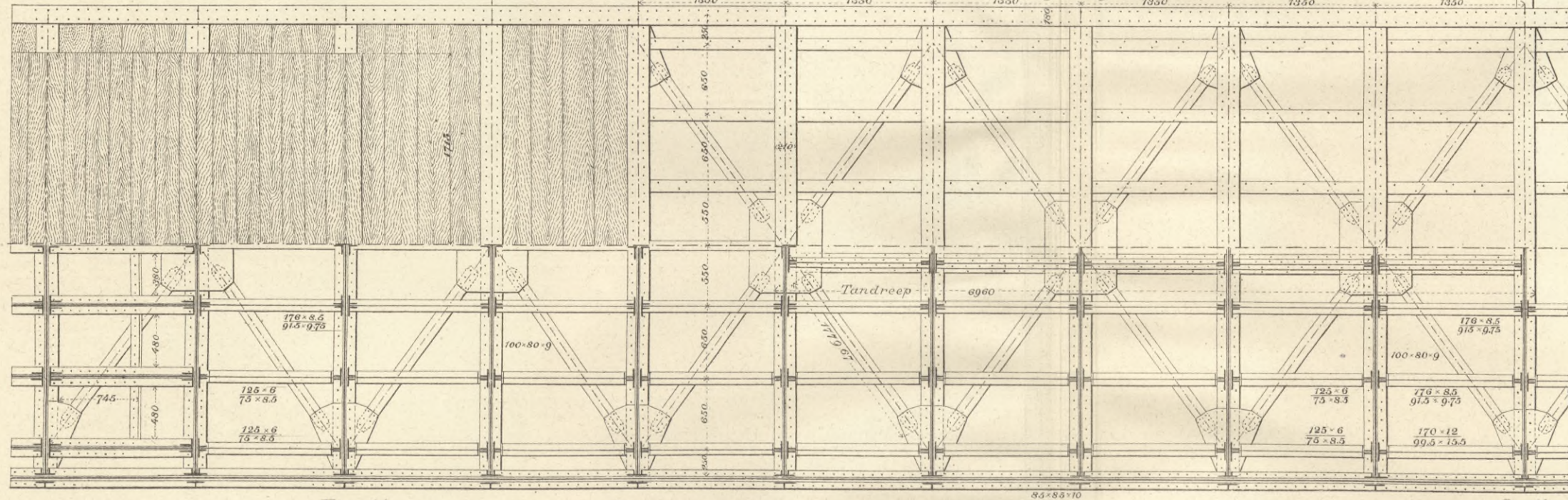

Normale dwarstigger. Fig. 3.

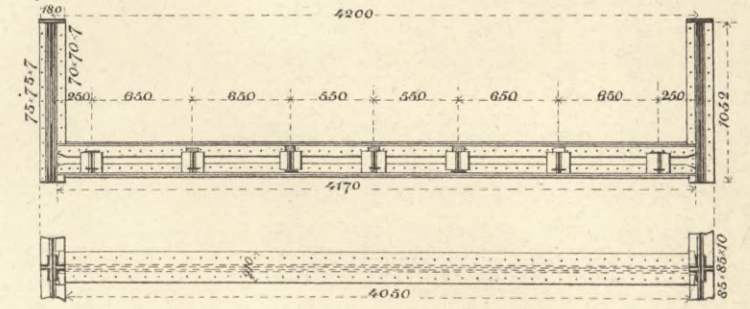

Normale langstigger onder de tram Fig. 5 Aanzicht.

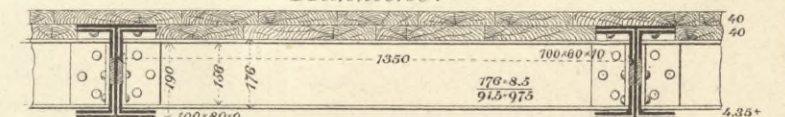

Normale langstigger onder het rijvlak Fig. 6 Aanzicht.

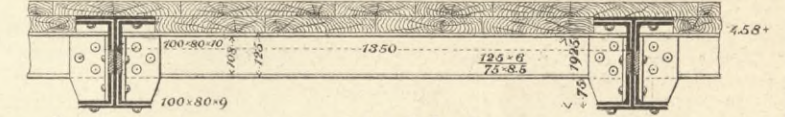

Langstigger in het laatste vak bij de koebrug (onder de tram) Aanzicht. Fig. 7.



Platte grond.

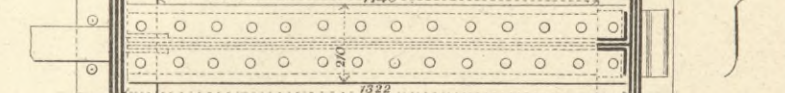

Langstigger in het laatste vak by de koebrug (onder het rijvlak) Aanzicht. Fig. 8.

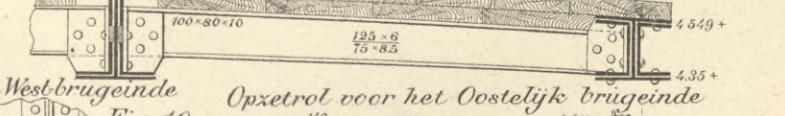
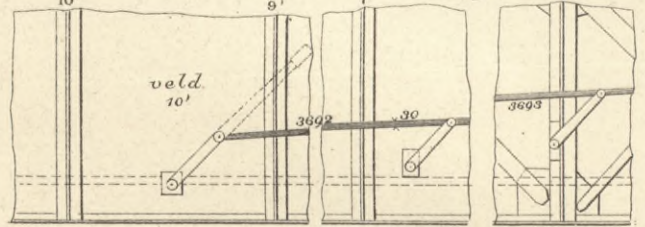
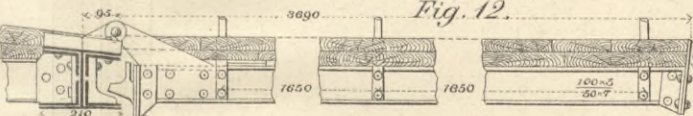

Fig. 11.

Inrichting tot het lichten der koebrug.



Langstigger der koebrug bij het scharnier. Fig. 12.



Opzetkussen Westbrugende Fig. 10



Opzetrol voor het Oostelyk brugende Fig. 9

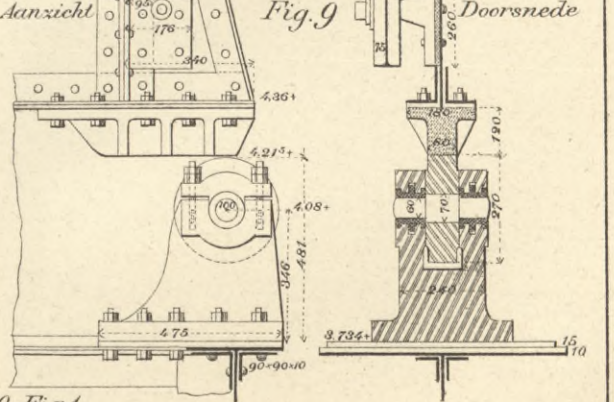

Achterhar koebrug Fig. 15.



Langstiggers koebrug Fig. 13 onder de tram

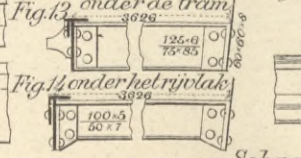
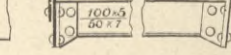

Fig. 14 onder het rijvlak



Schaal 1:20 Fig. 5-16.

Schaal 1:50 Fig. 2, 3, 4.

Schaal 1:300 Fig. 1.

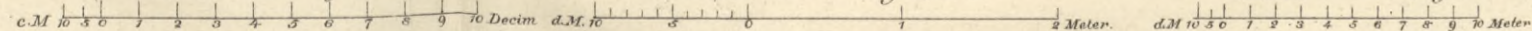





















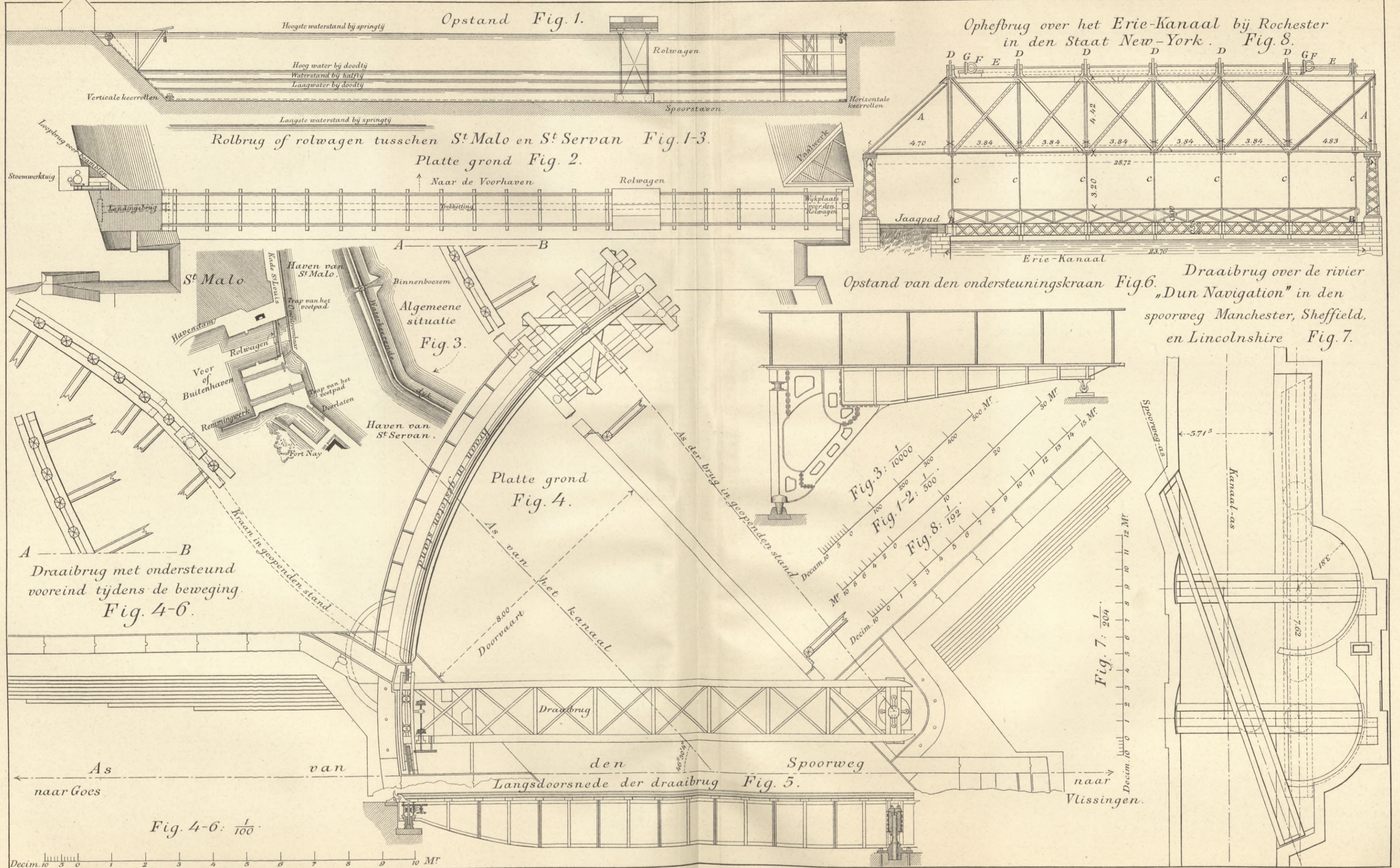





Ophefbrug over het Oswega-Kanaal in den spoorweg "New-York, Westshore en Buffalo,"

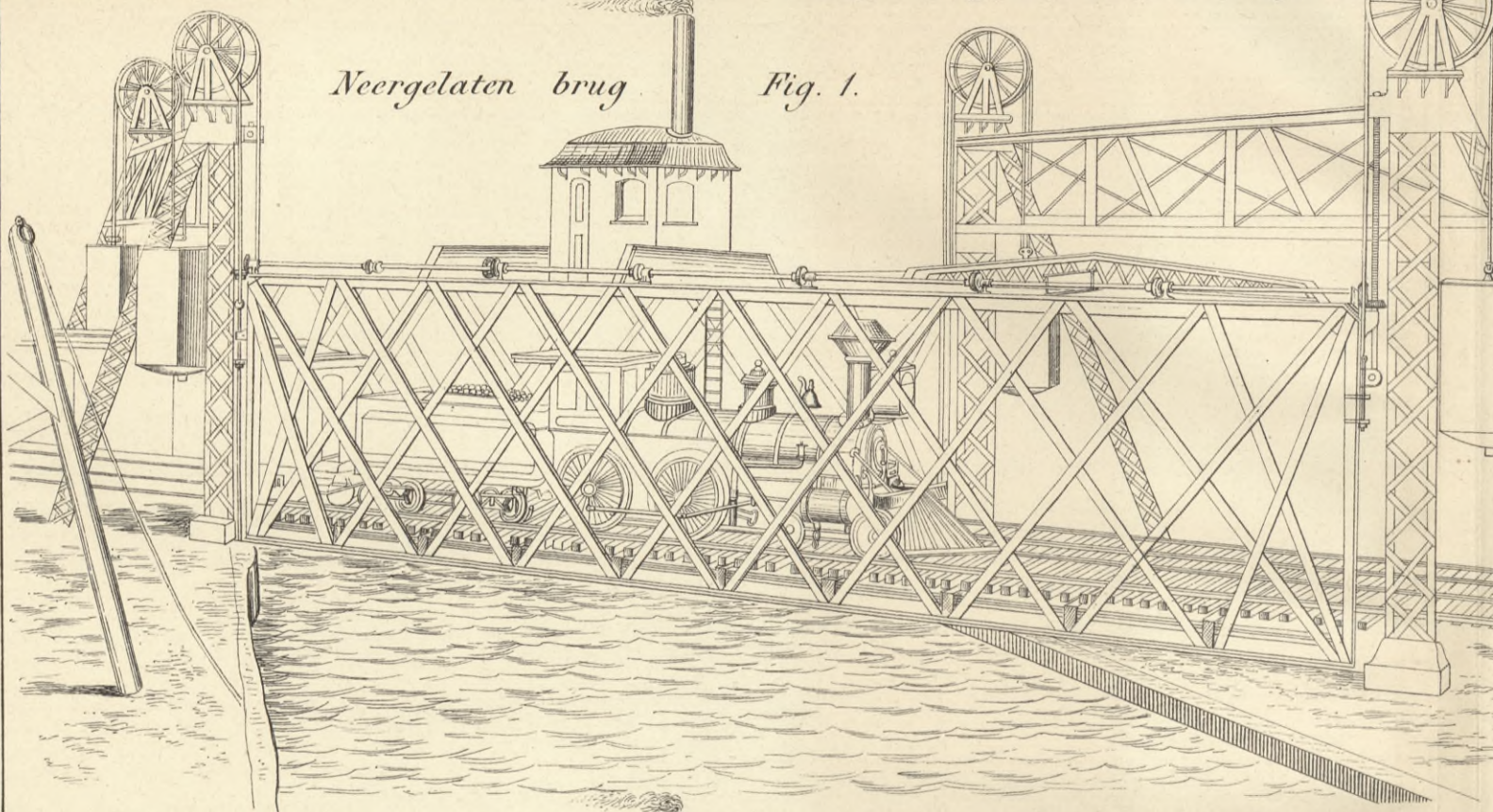

Neergelaten brug Fig. 1.

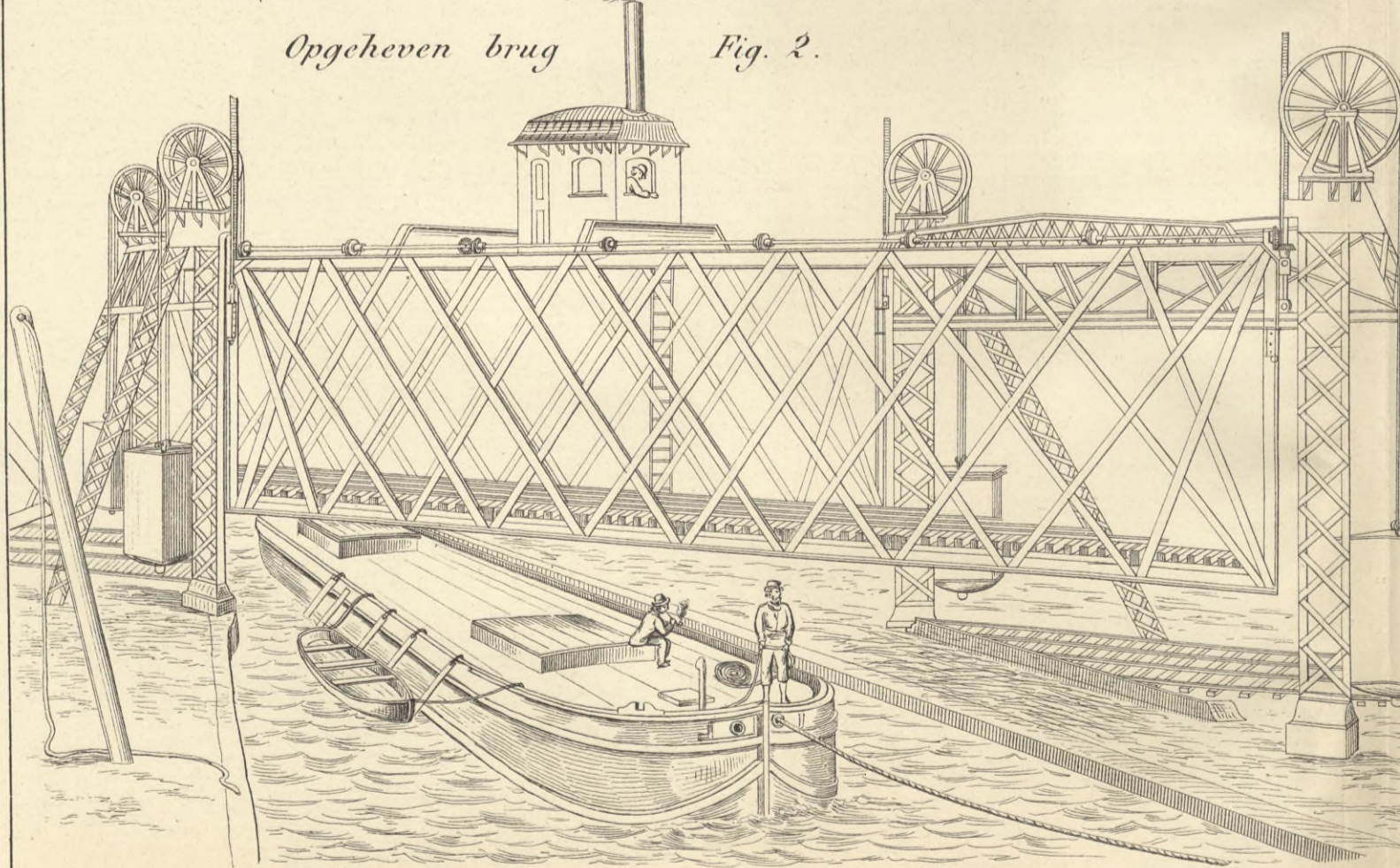

Opgeheven brug Fig. 2.

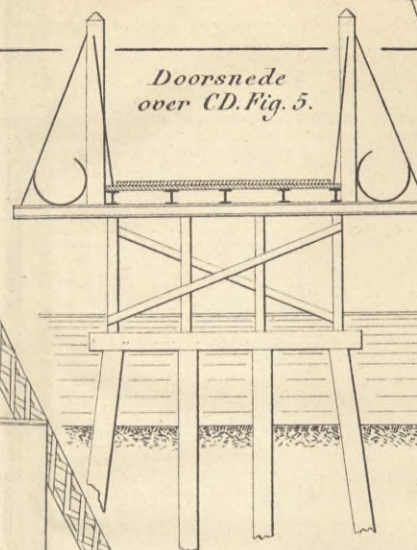

Doorsnede over CD Fig. 5.

Brug over de Keelgracht van het fort te Abcoude Fig. 3-5.

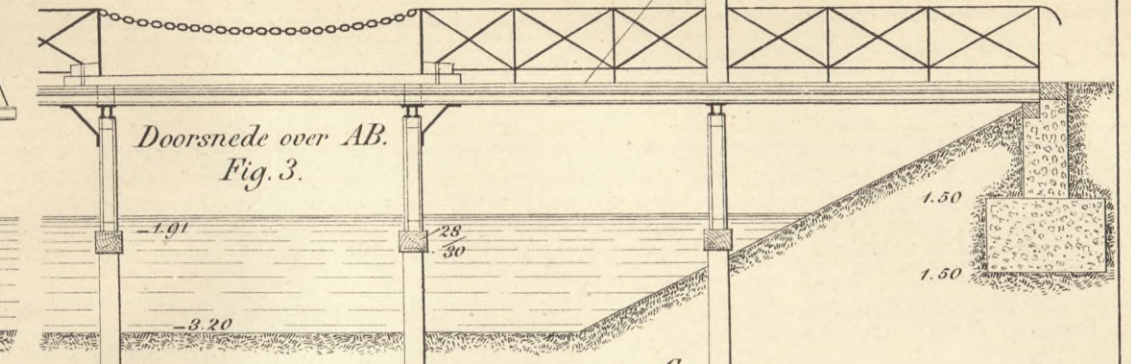

Platte grond Fig. 4.

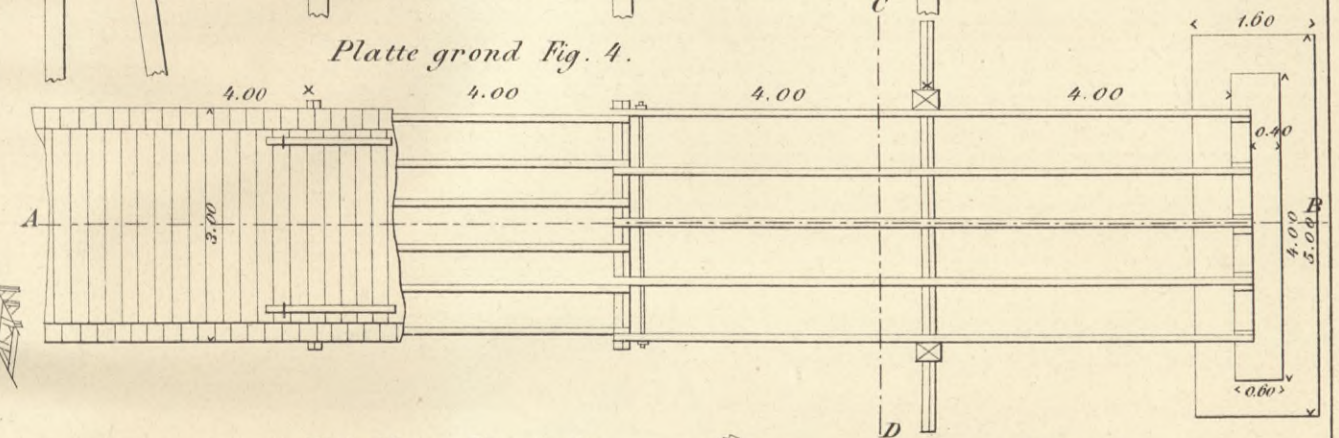

Dwarsdoorsnede over het vastgedeelte Fig. 8.

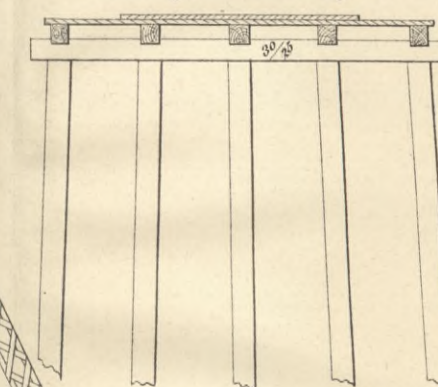

Hefrolbrug Fig. 6-8.

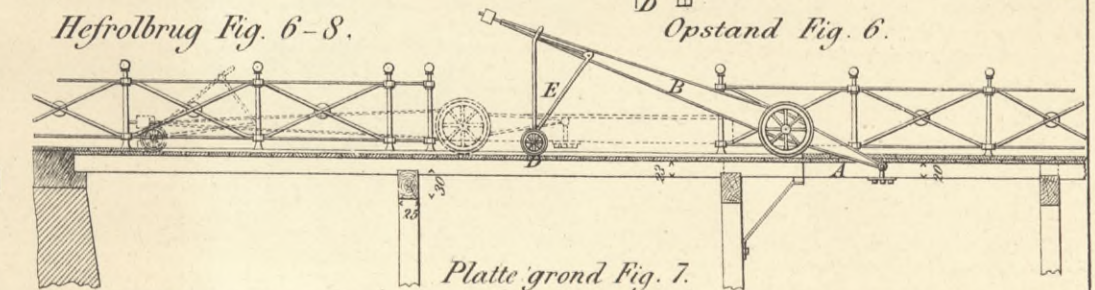

Opstand Fig. 6.

Platte grond Fig. 7.

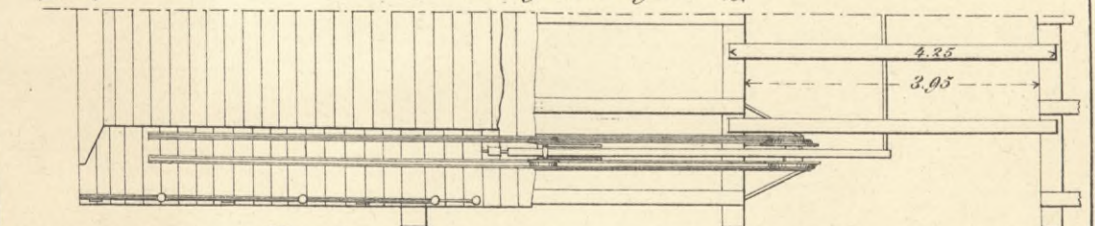

Fig. 9.

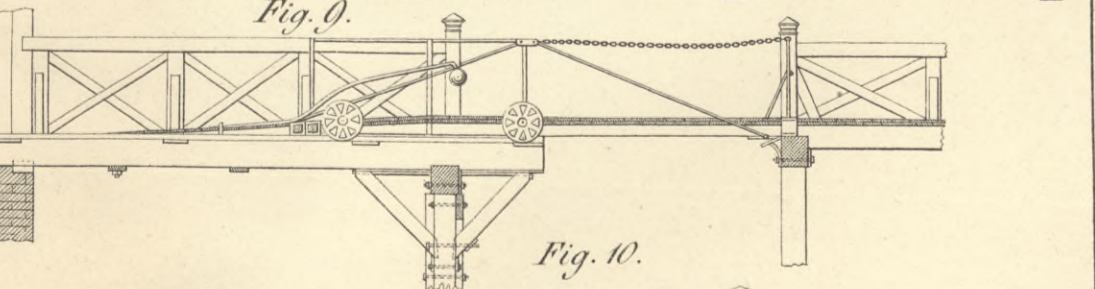
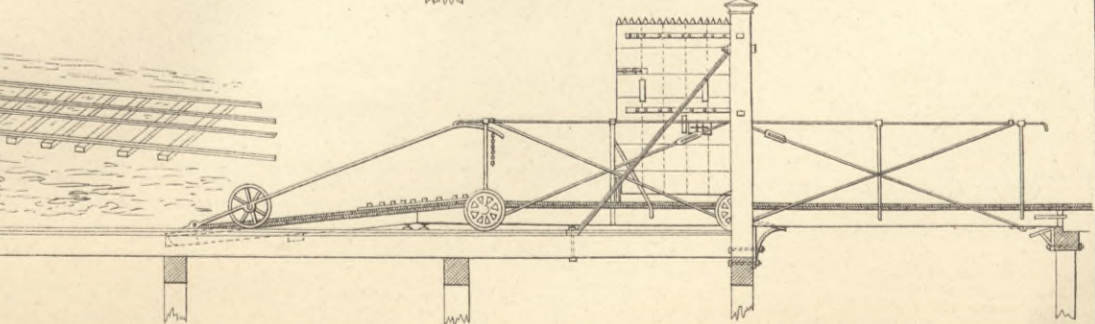

Fig. 10.



Decim. 10 3 0 1 2 3 4 5 6 7 8 9 10 M<sup>r</sup>





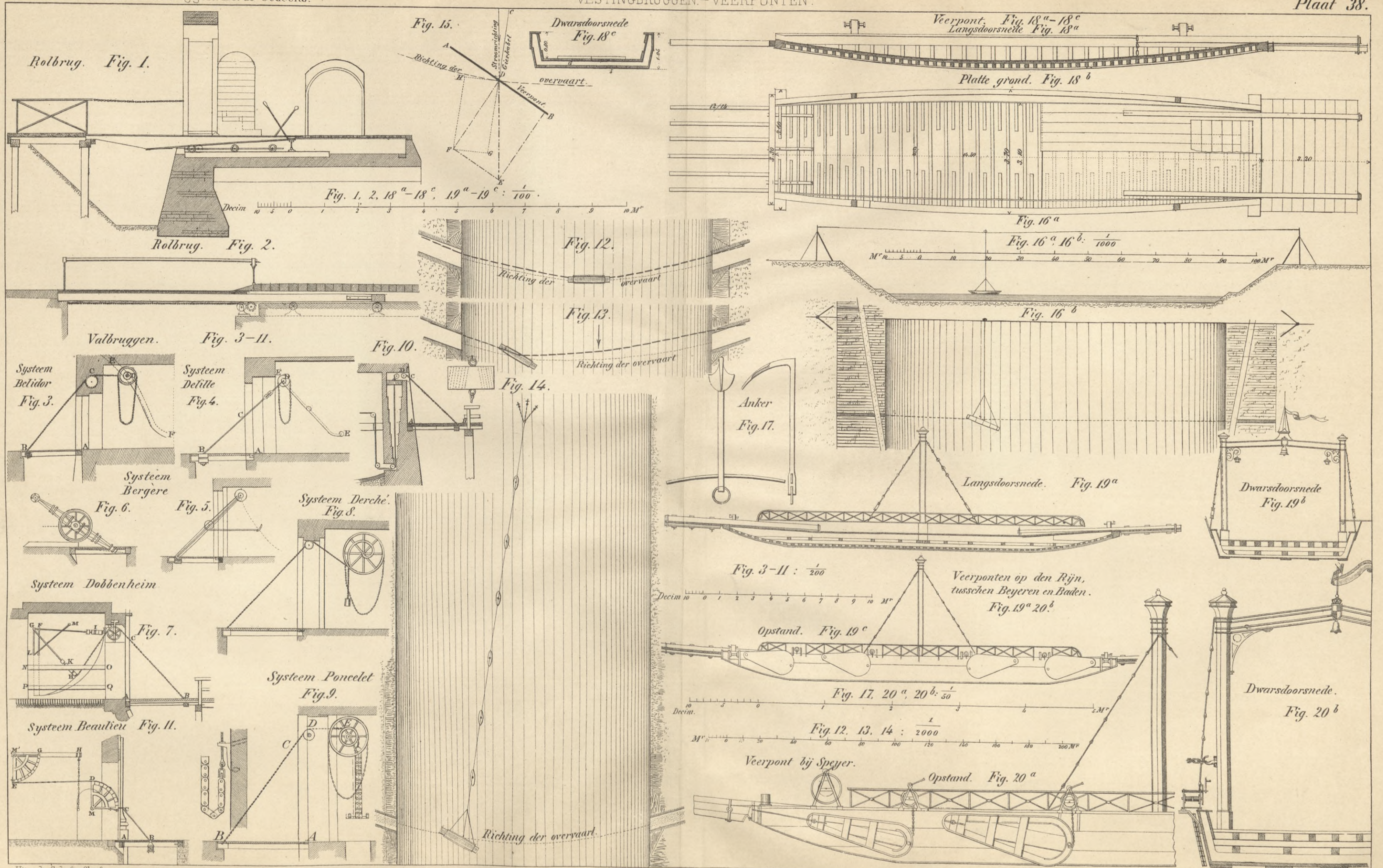







Gierbrug te Nijmegen. Fig. 1-8.  
Langsdoorsnede. Fig. 1.

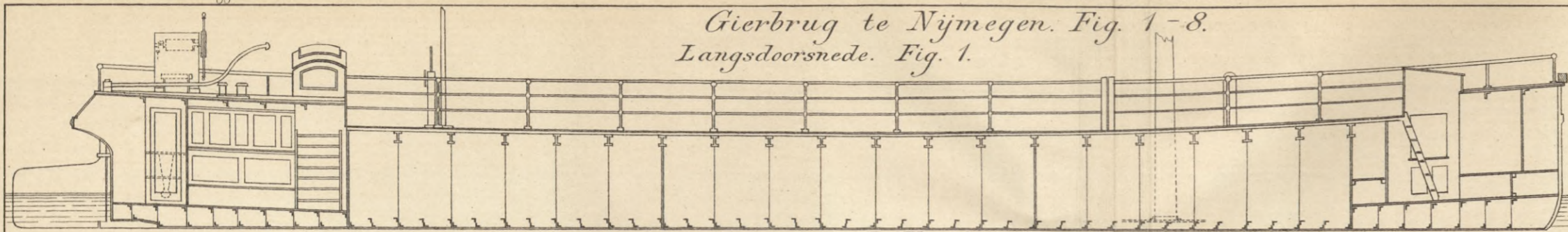

Platte grond. Fig. 2.

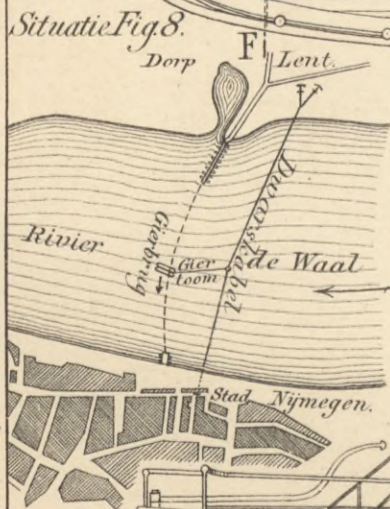
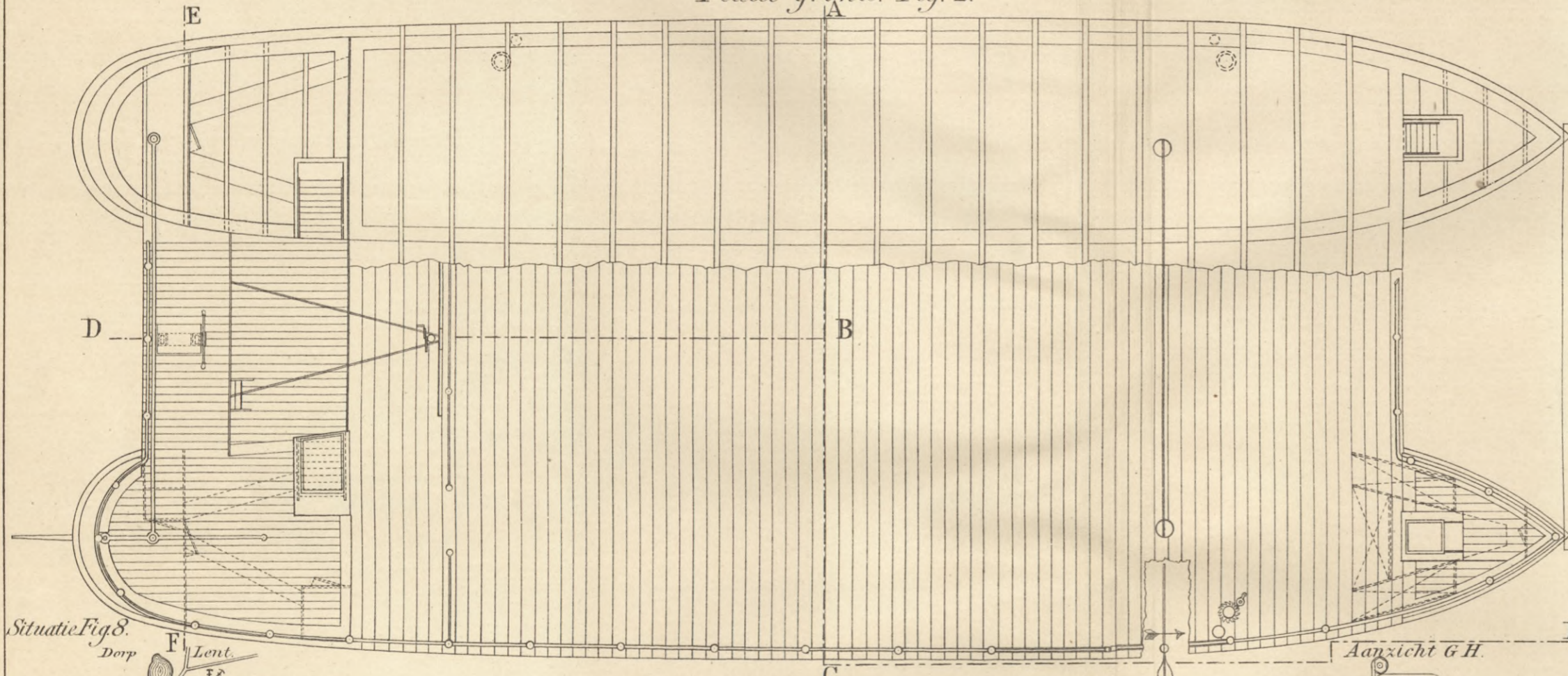
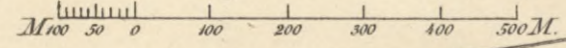

Fig. 8: 1/10000.



Doorsnede over DBCD' Fig. 3.

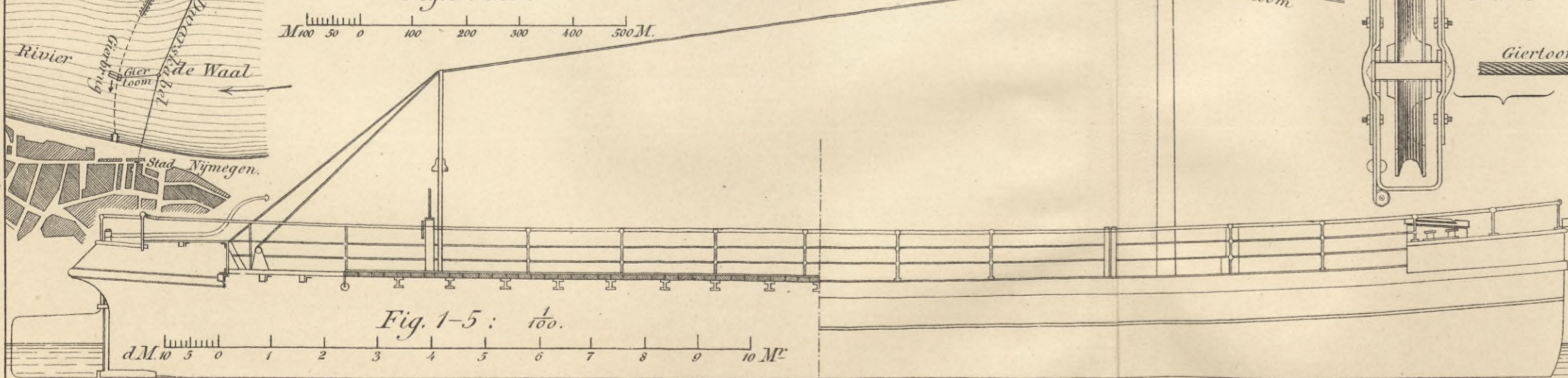
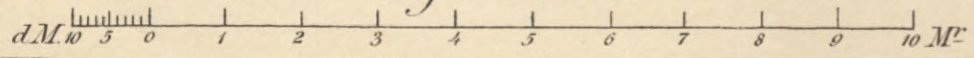
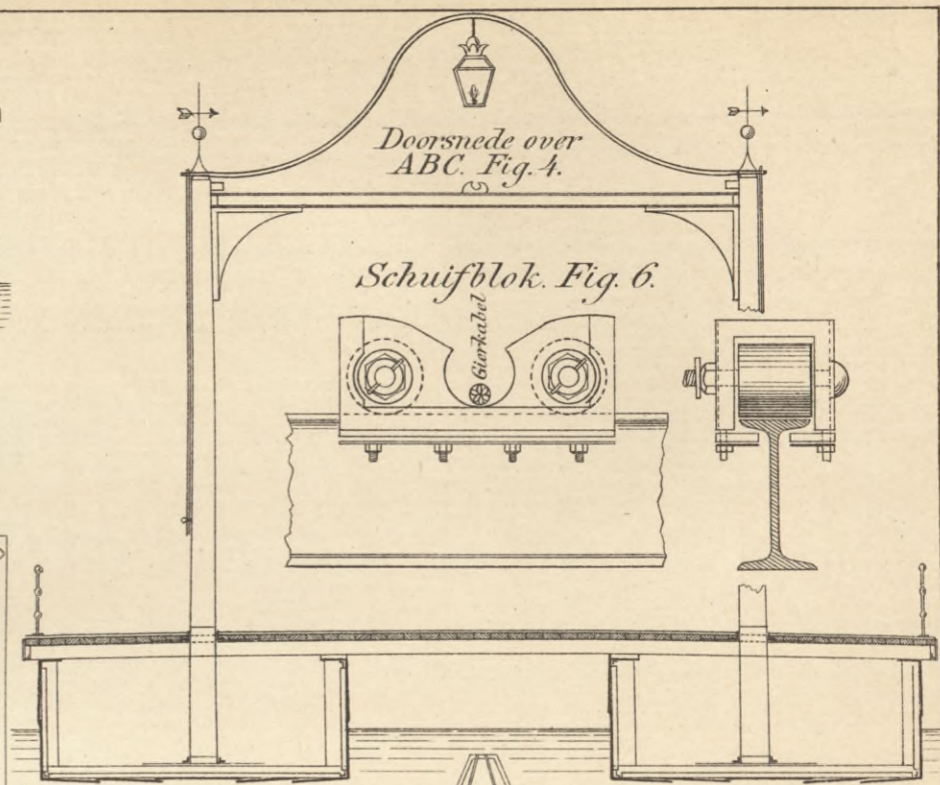

Fig. 1-5: 1/100.



Doorsnede over ABC Fig. 4.

Schuifblok Fig. 6.



Doorsnede over E F Fig. 5.

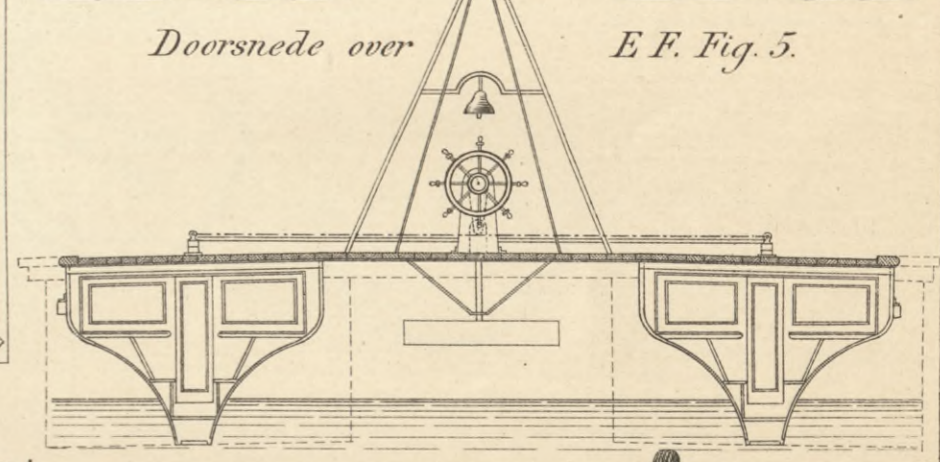
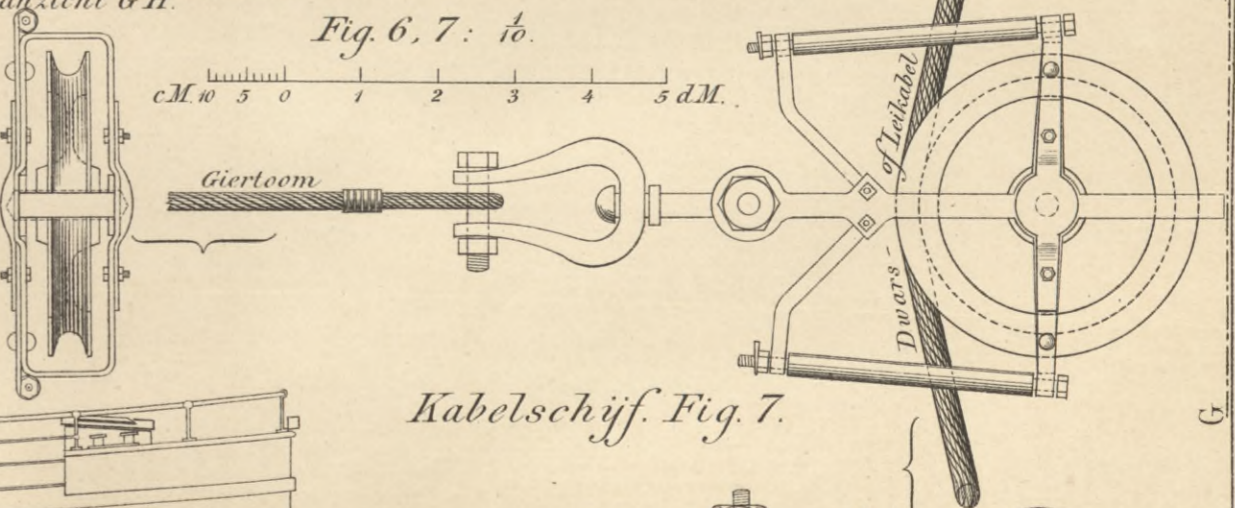
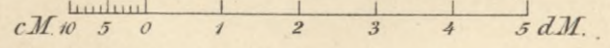

Fig. 6, 7: 1/10.



Kabelschijf Fig. 7.





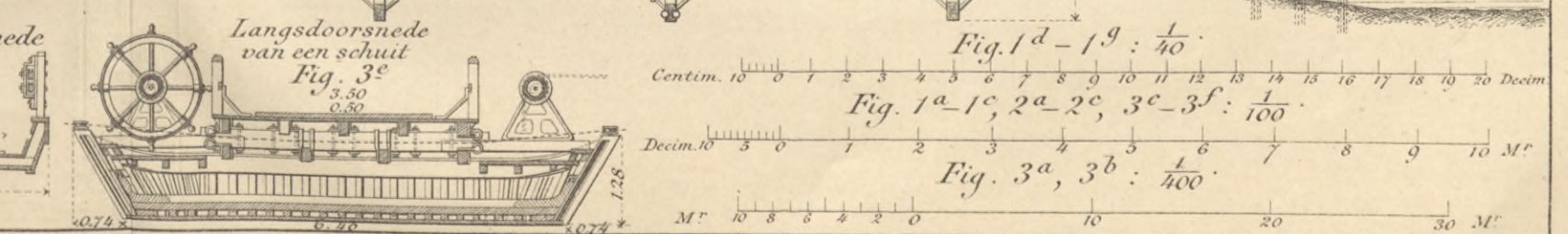
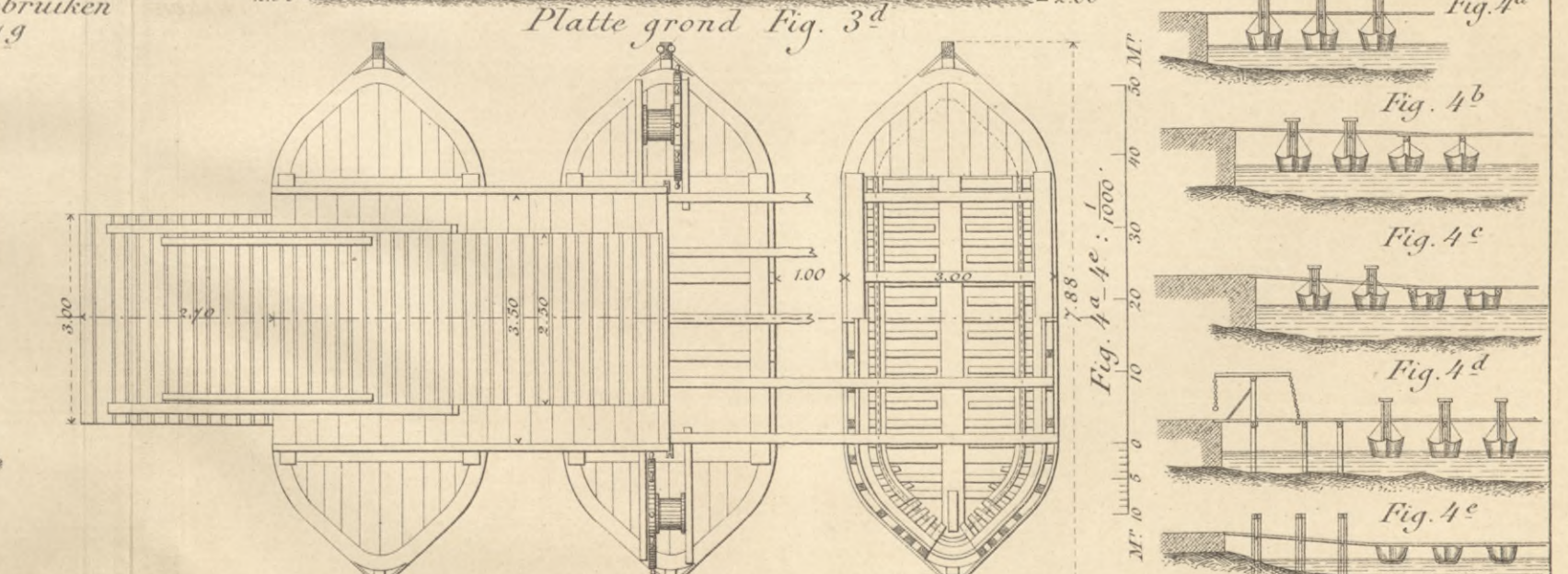
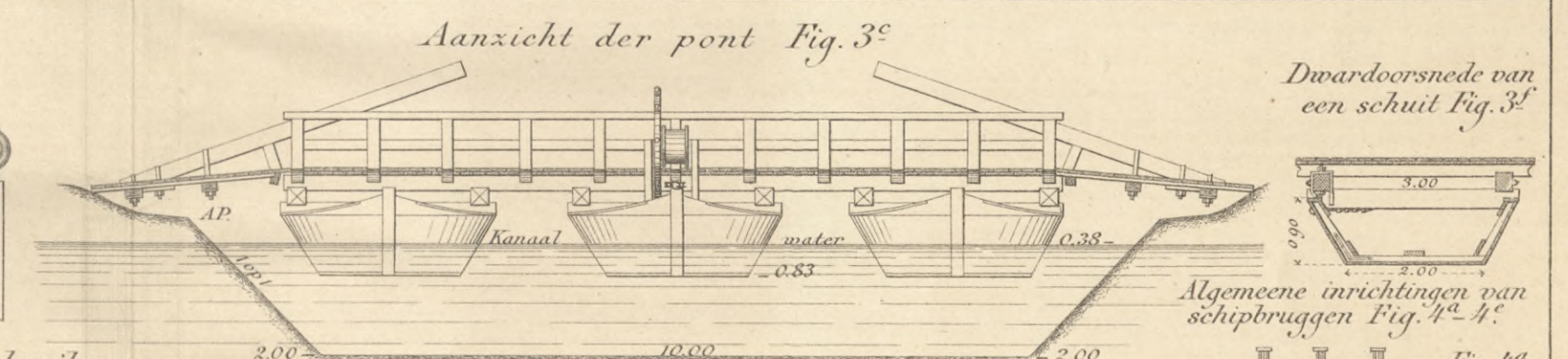
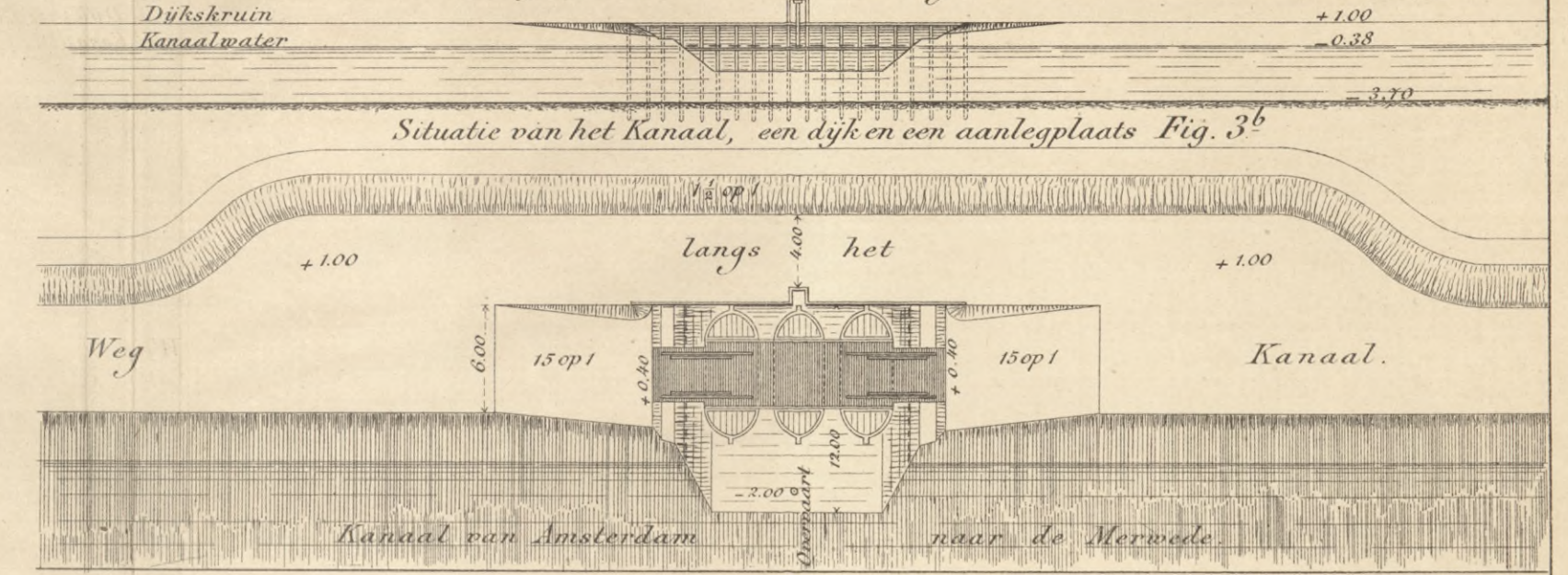
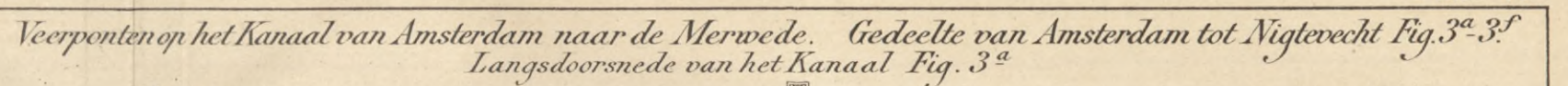
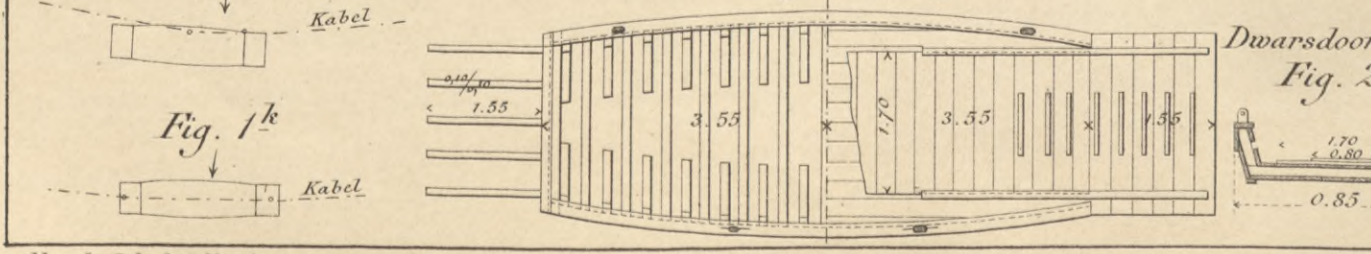
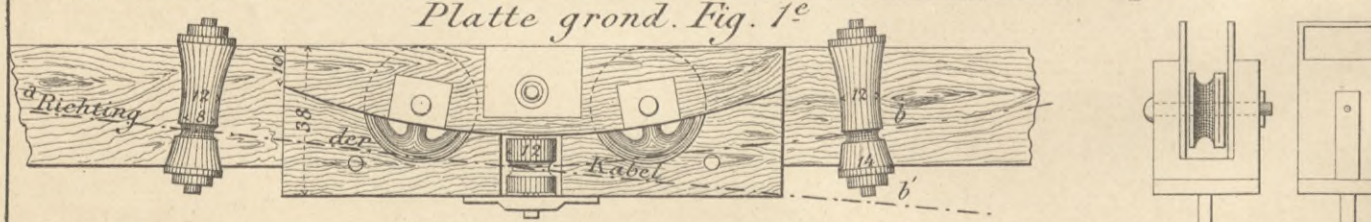
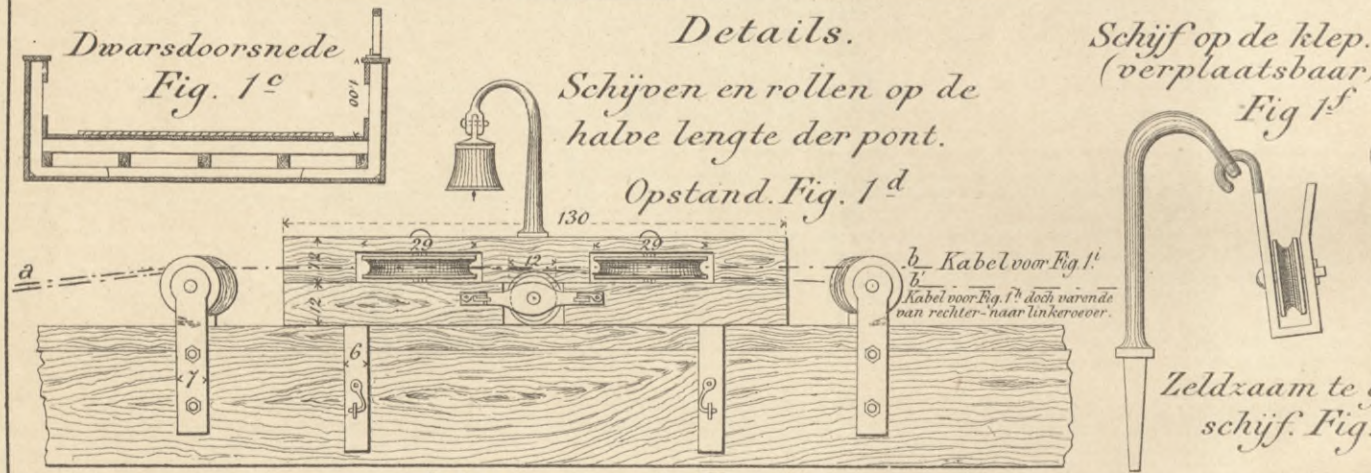
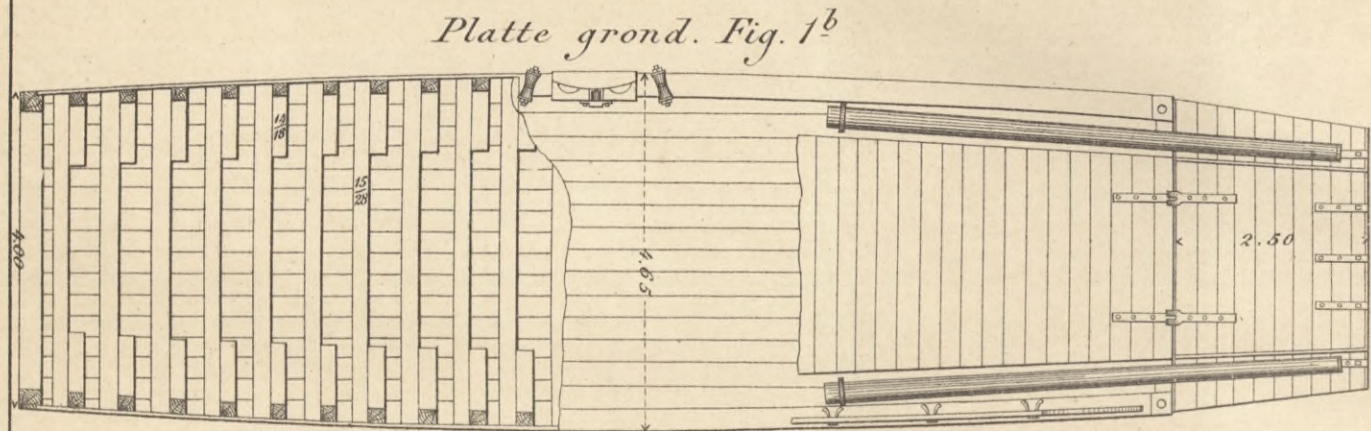
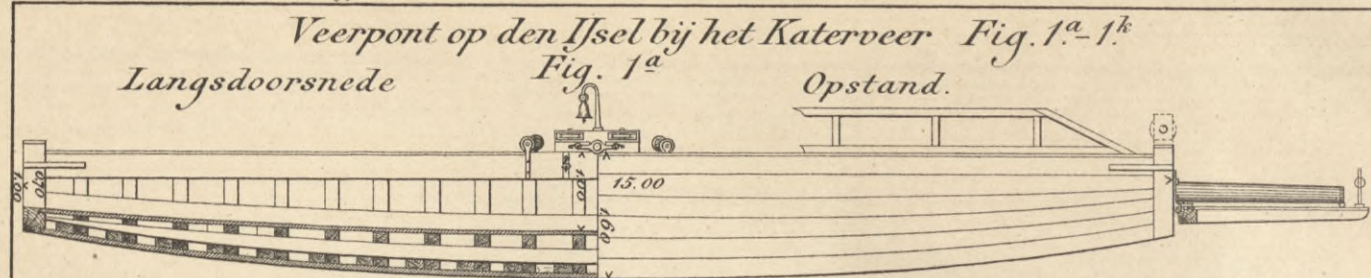



















Brug over den Ysel te Doesburg. Fig. 1-10.

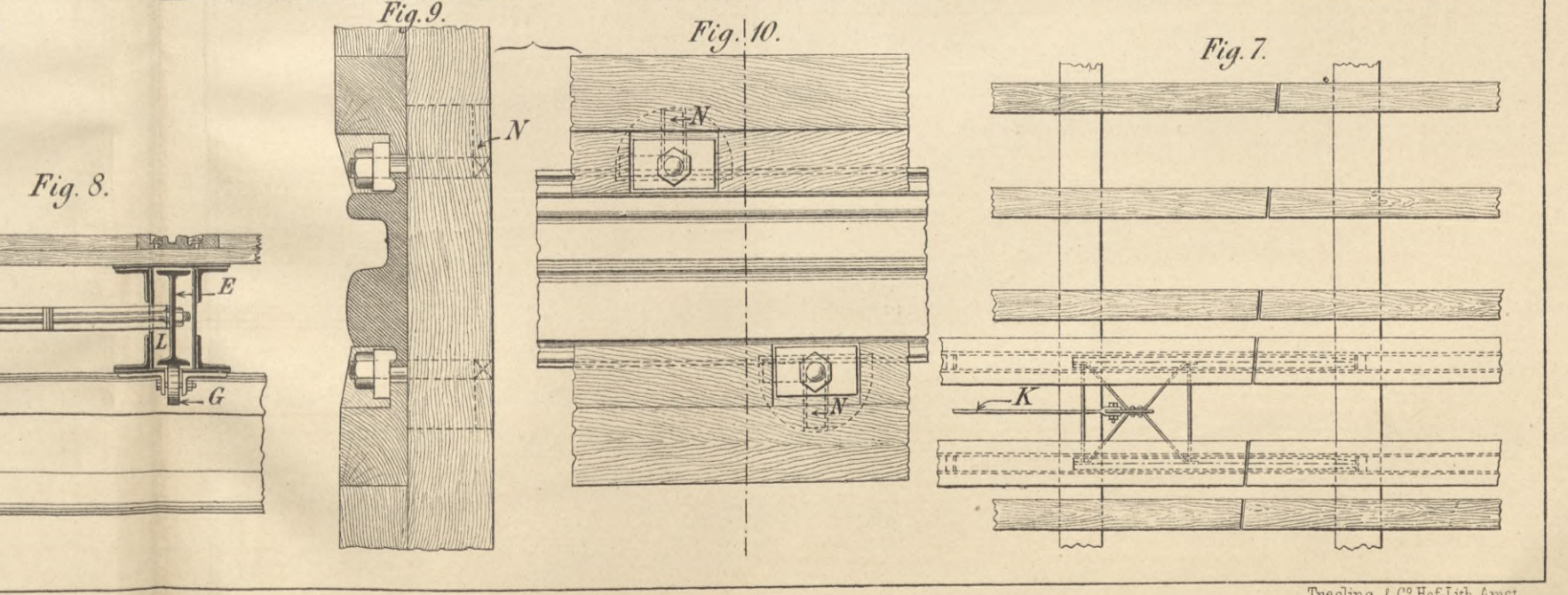
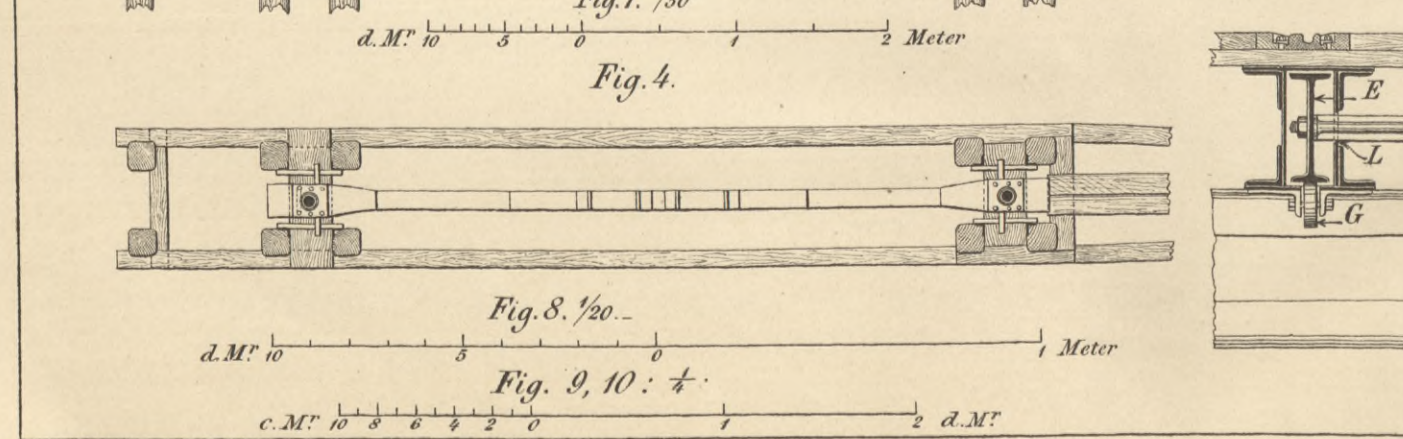
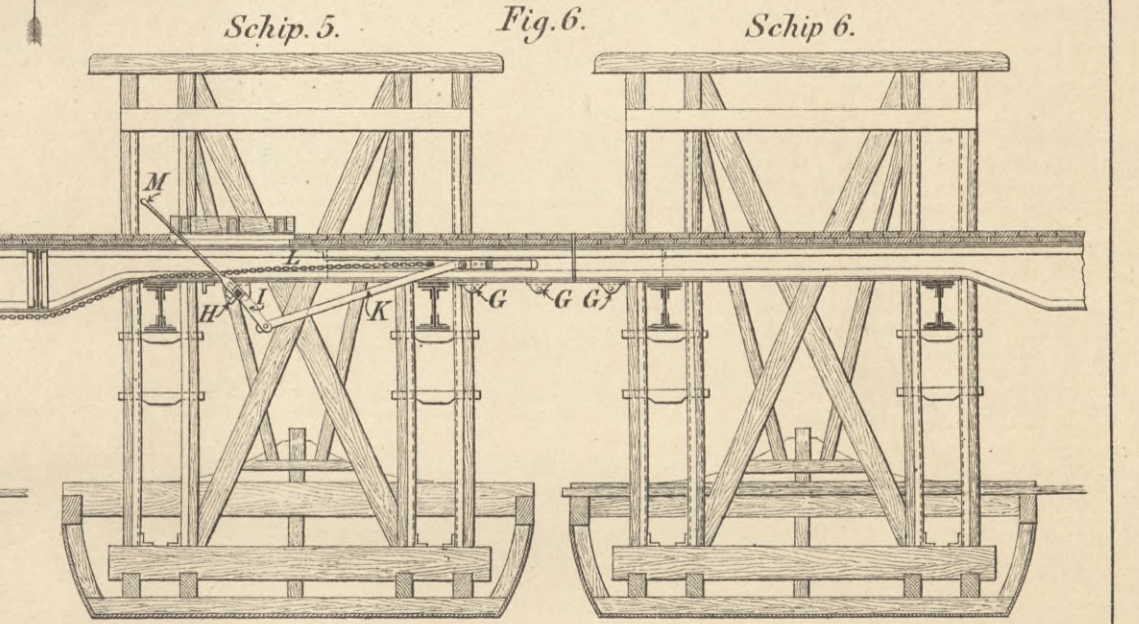
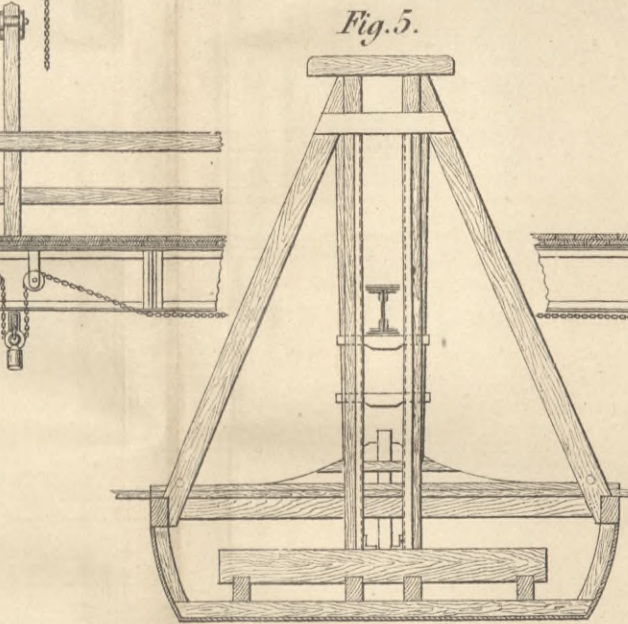
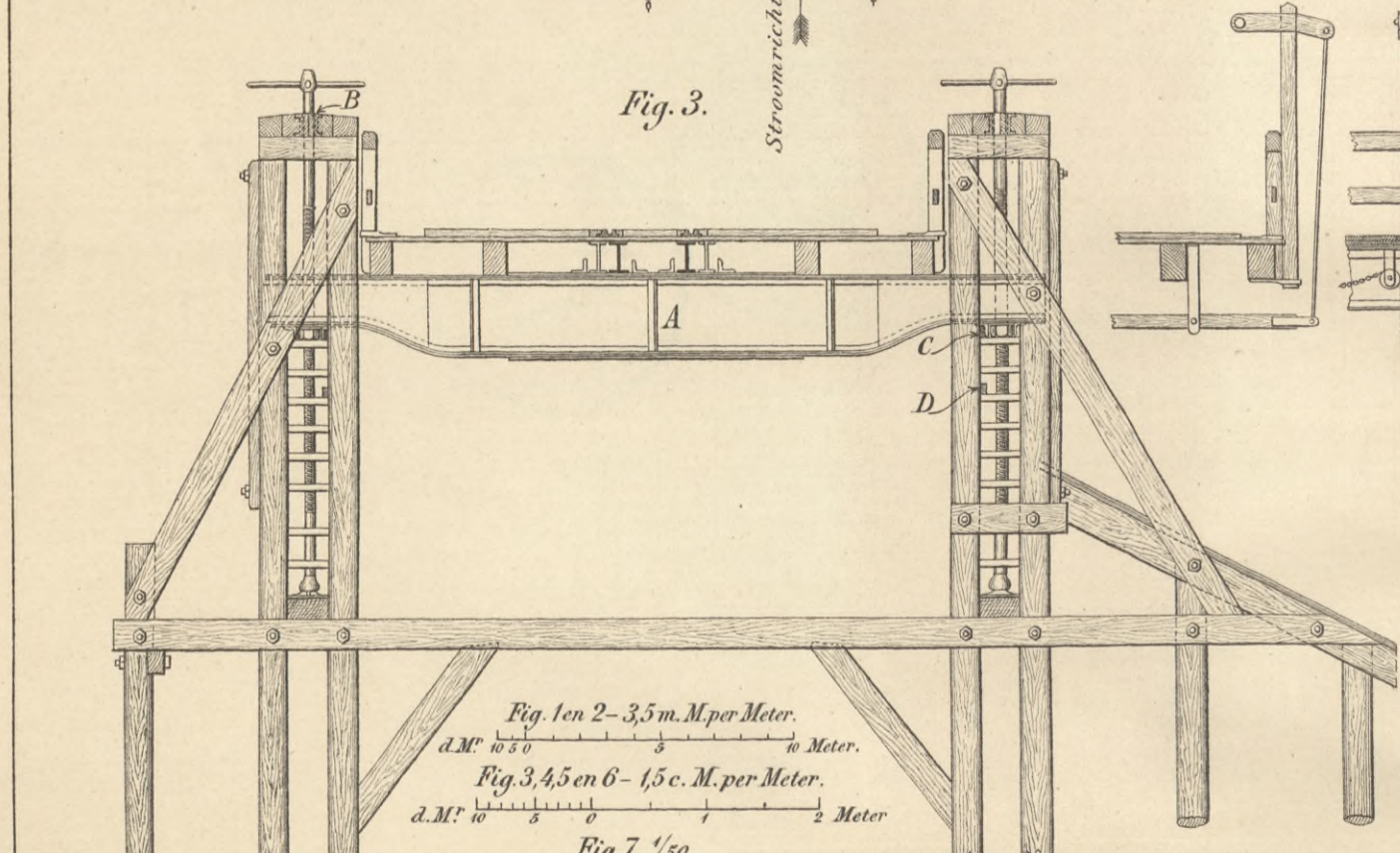
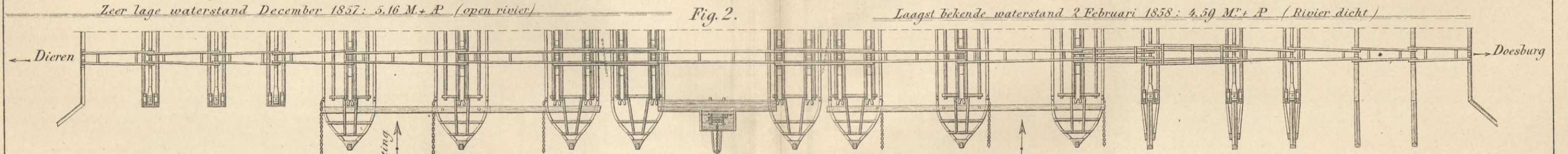
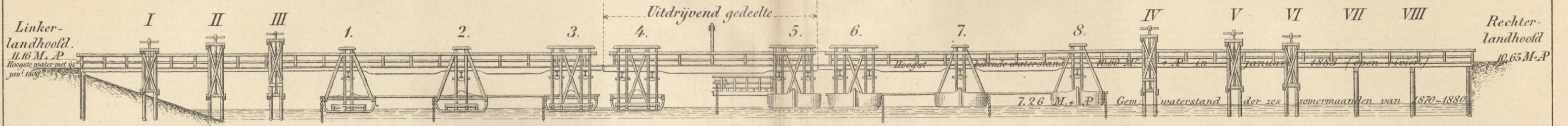







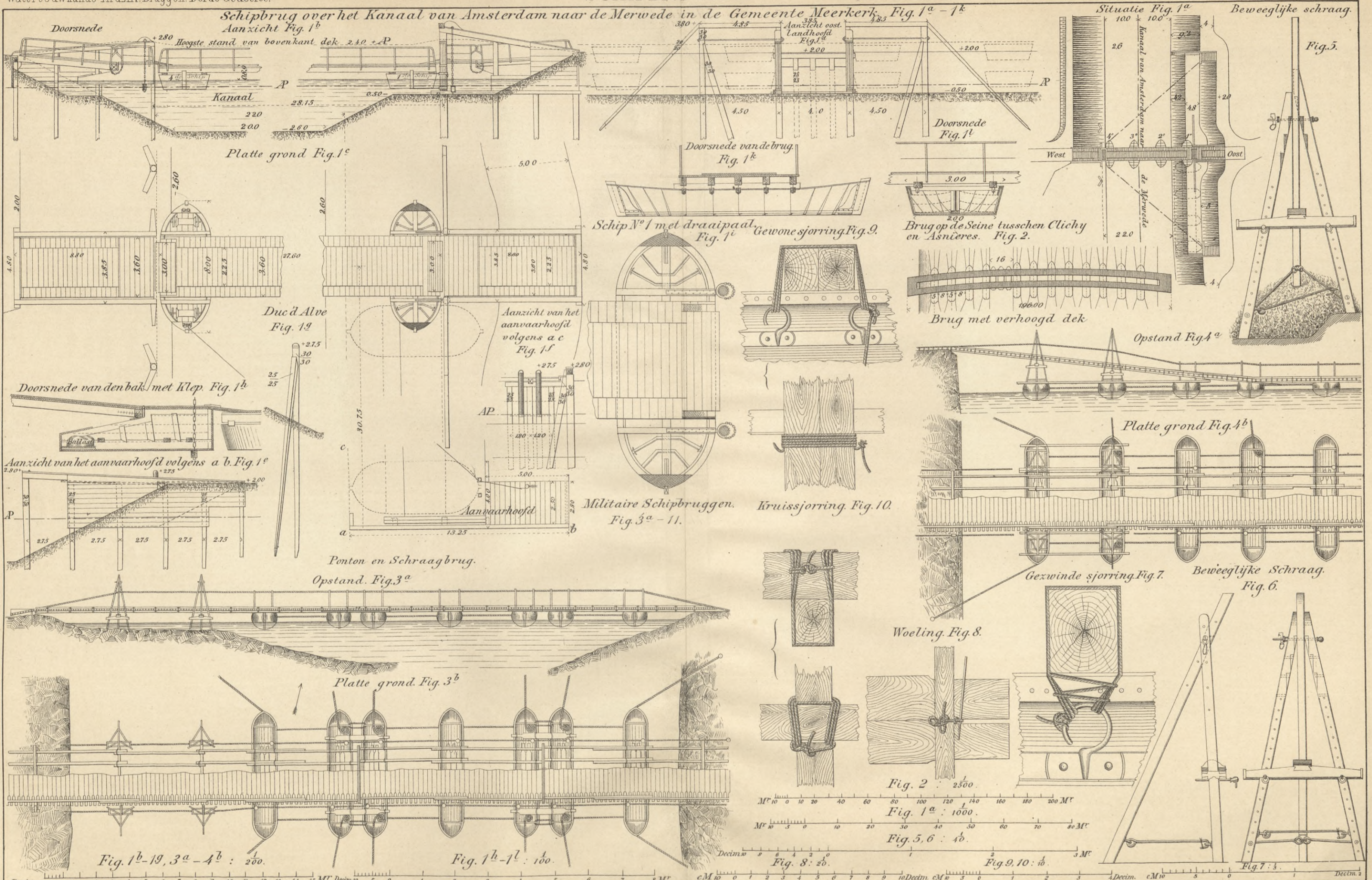





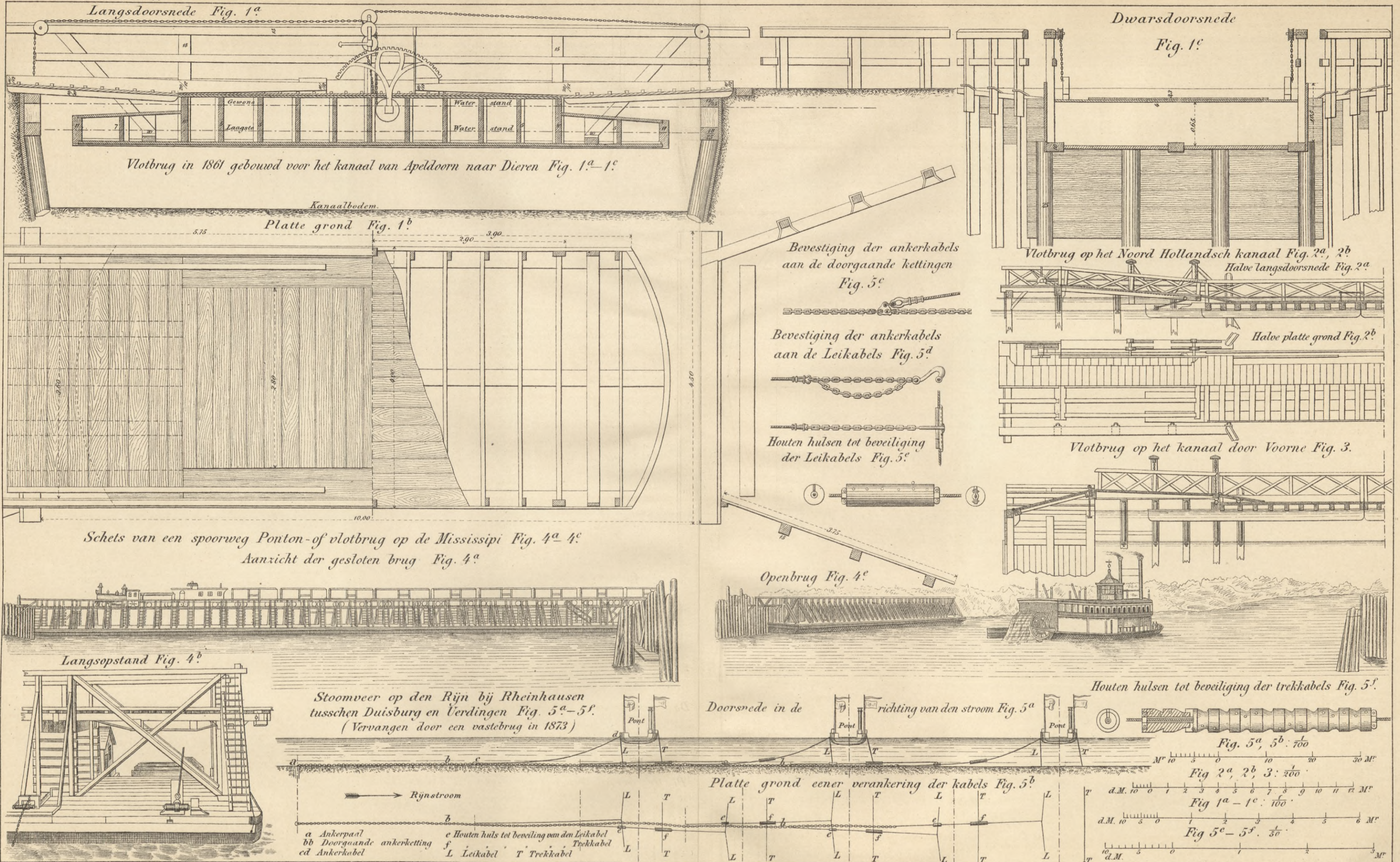





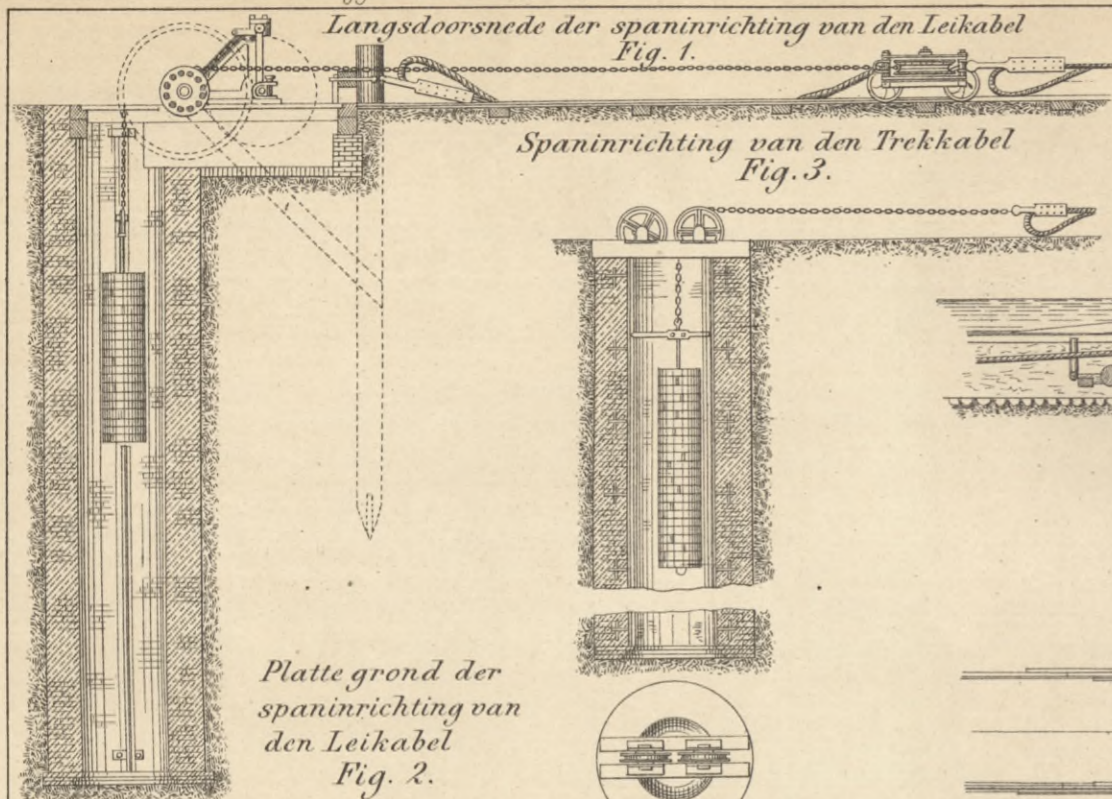

Stoomveer op den Rijn bij Rheinhausen tusschen Duisburg en Verdingen (Vervangen door een vaste brug in 1873.)

Zijaanzicht van den overgangswagen en van een Pont-eind. Fig. 4.

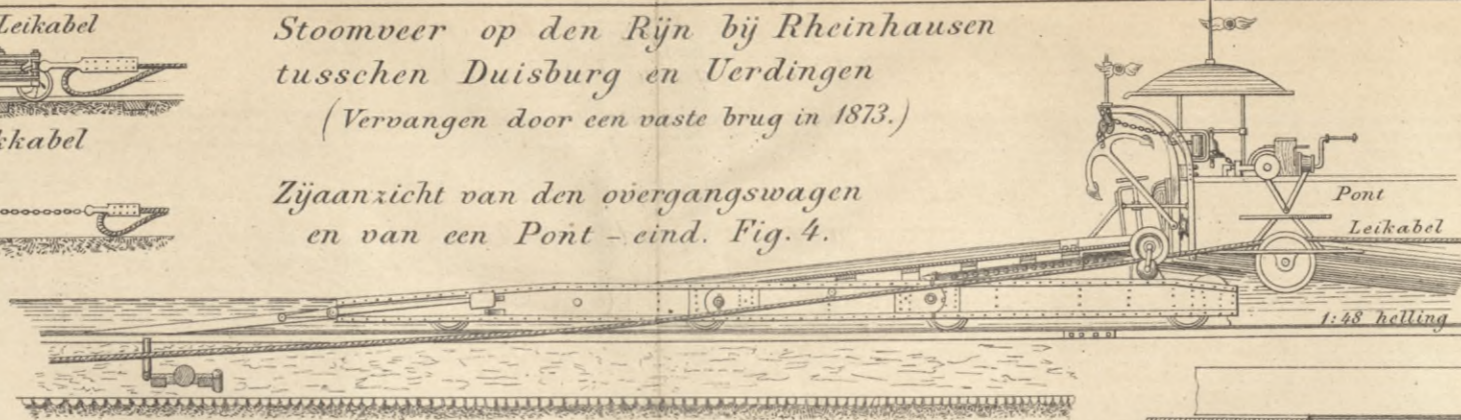

Platte grond van den overgangswagen en van een Pont-eind. Fig. 6.

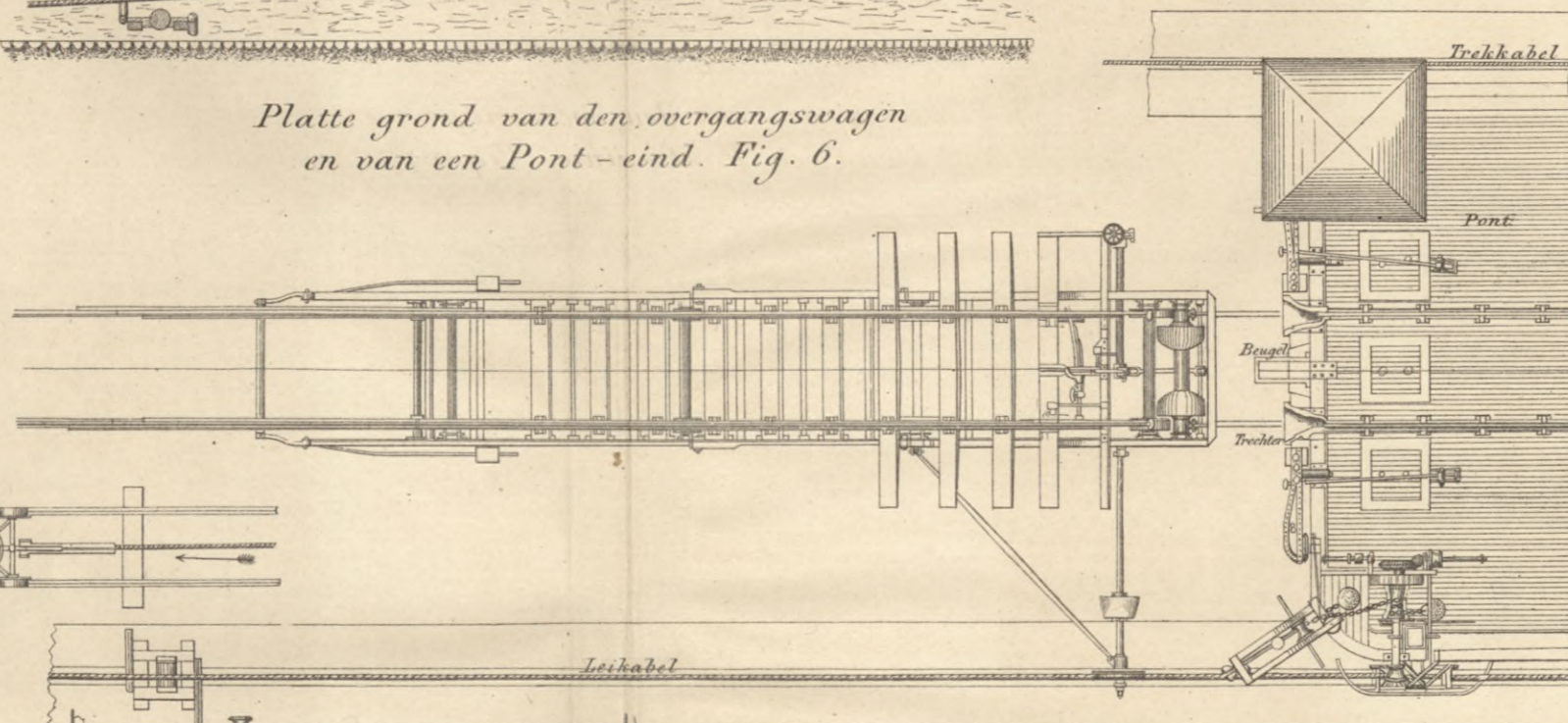

Leirollen van de Leikabels Fig. 11.

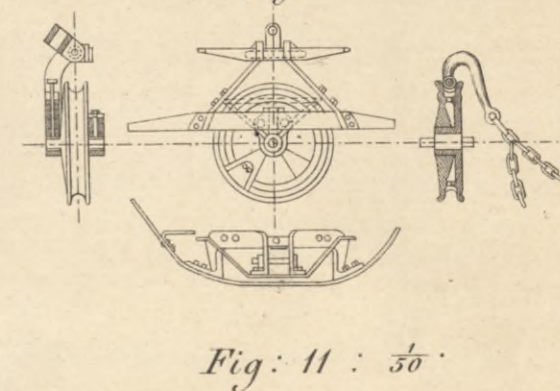

d.M. 10 5 0 1 2 M.

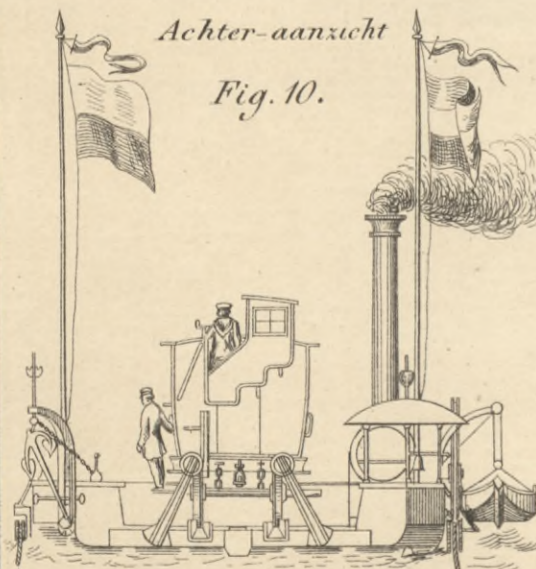

Zijaanzicht der beladen Pont Fig. 9.

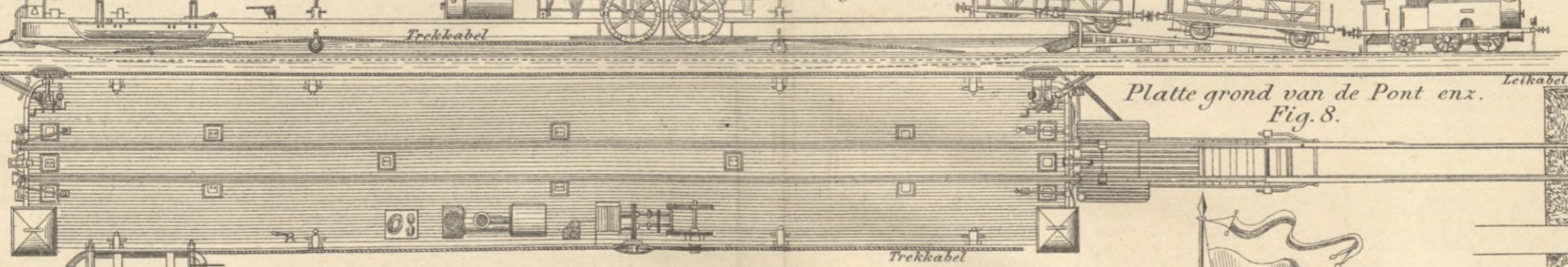

Zijaanzicht der beladen Pont Fig. 9.

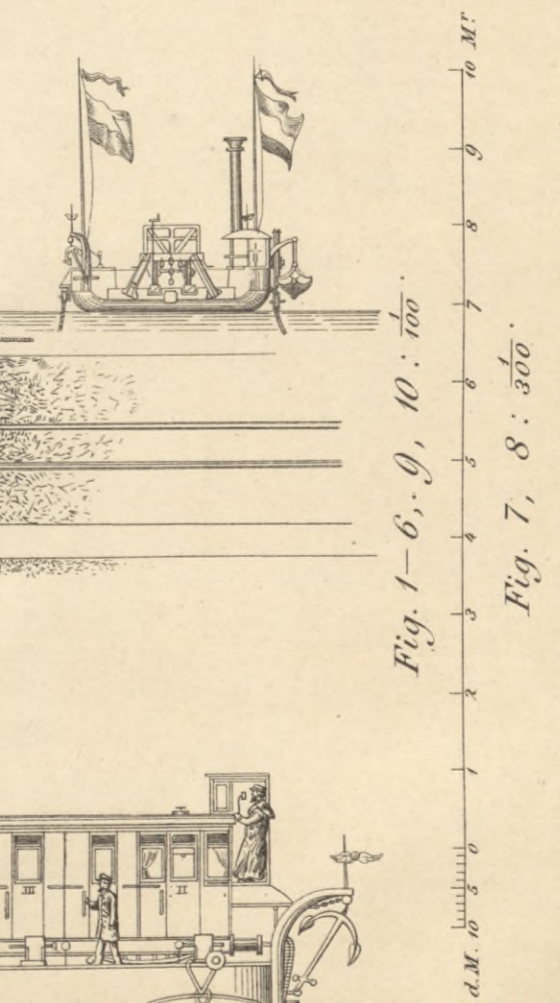
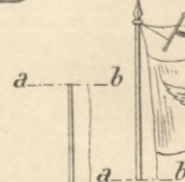







Algemeene inrichting van Port-Costa, nabij het station van Martinez. Fig. 1.<sup>a</sup>

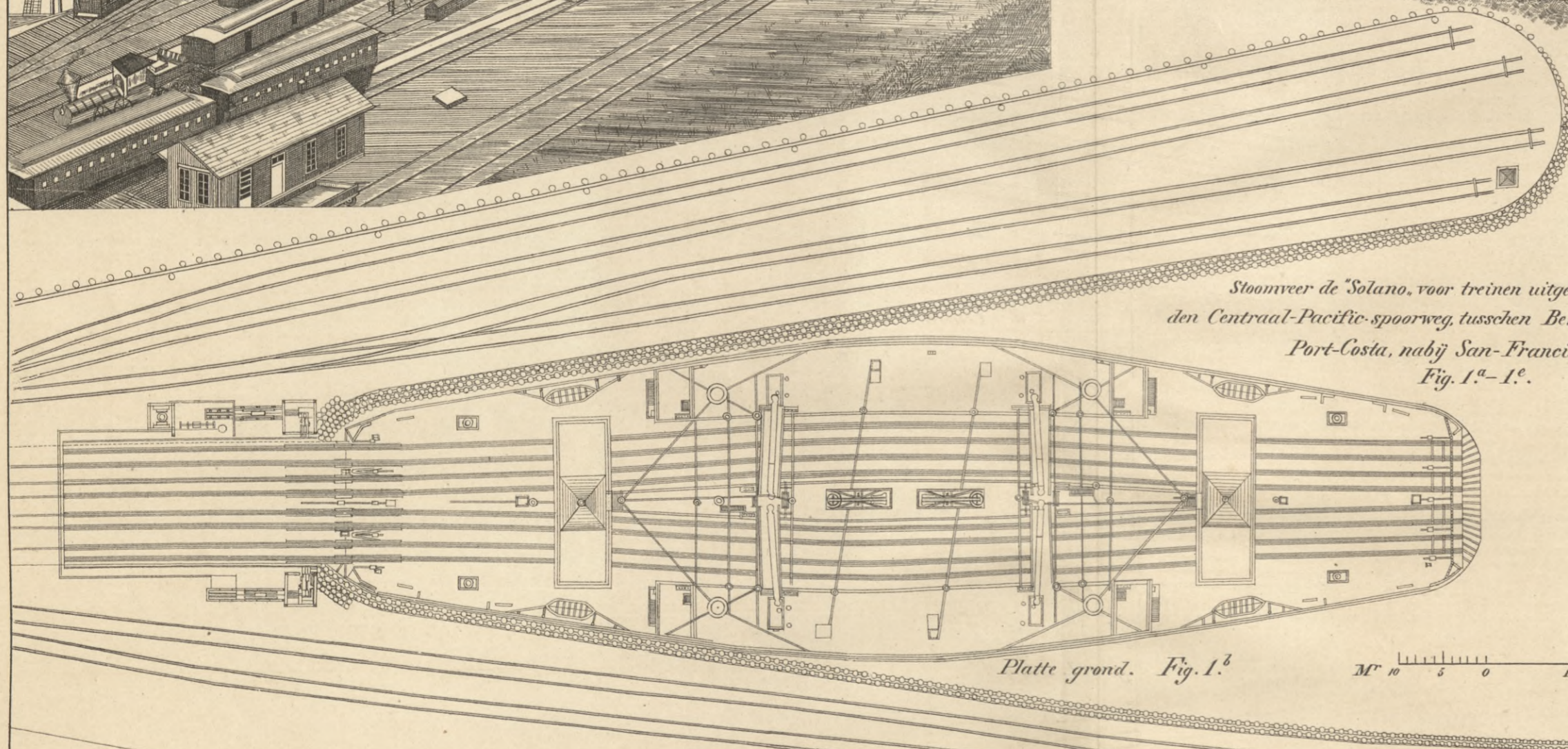
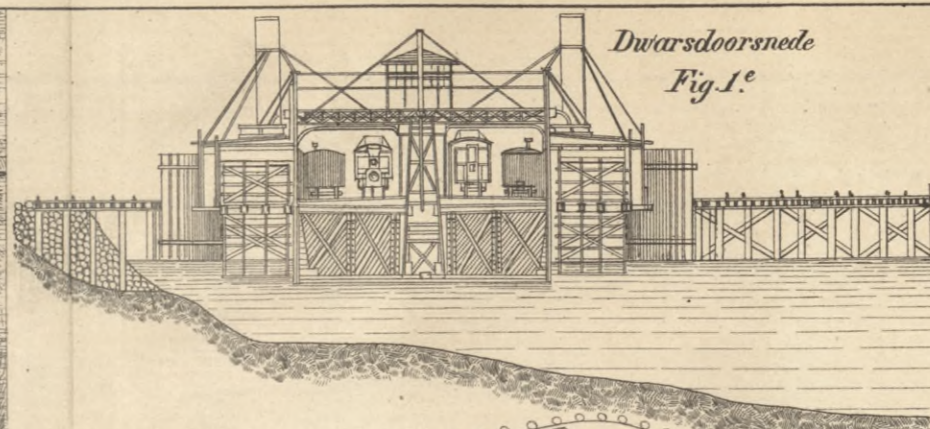
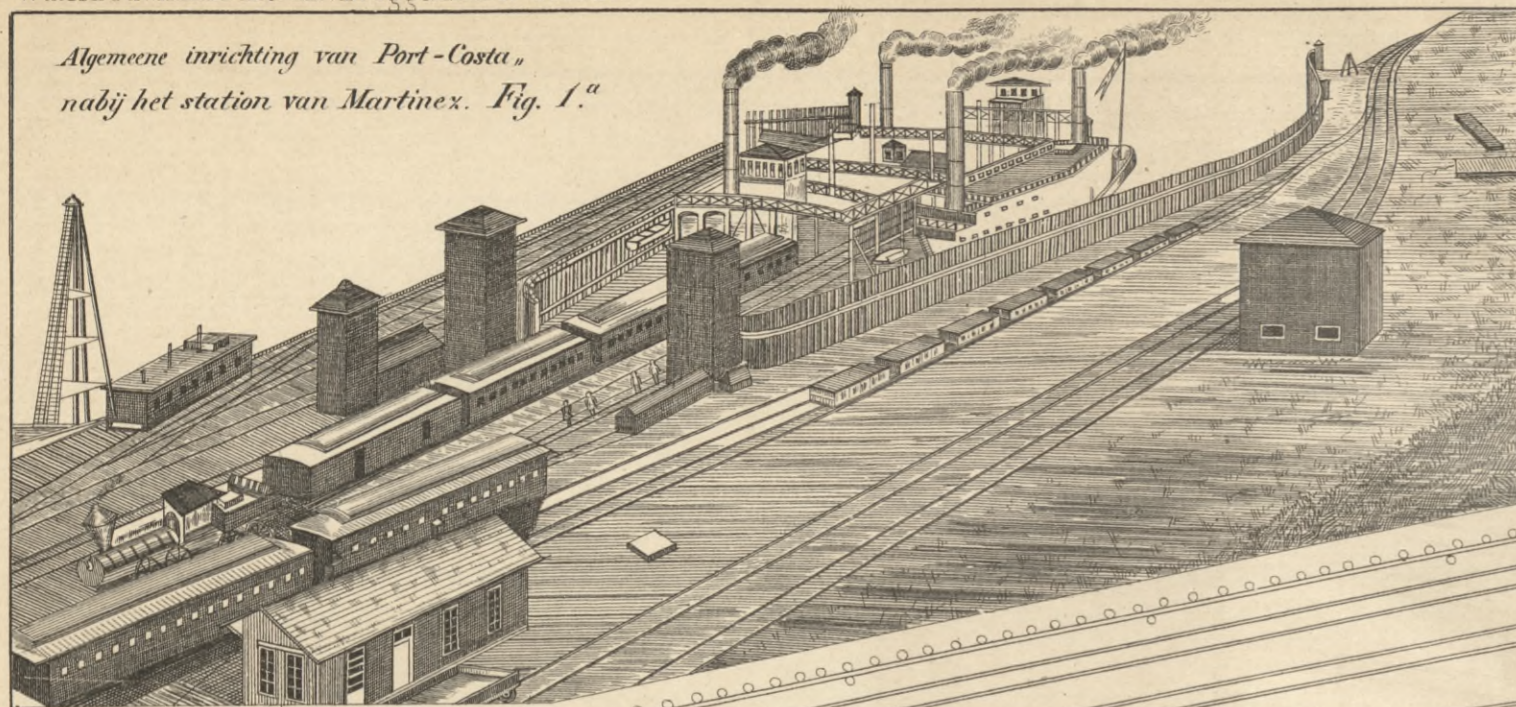

Stoomveer de "Solano, voor treinen uitgevoerd door den Centraal-Pacific-spoorweg, tusschen Beneficia en Port-Costa, nabij San-Francisco. Fig. 1.<sup>a</sup>-1.<sup>c</sup>.

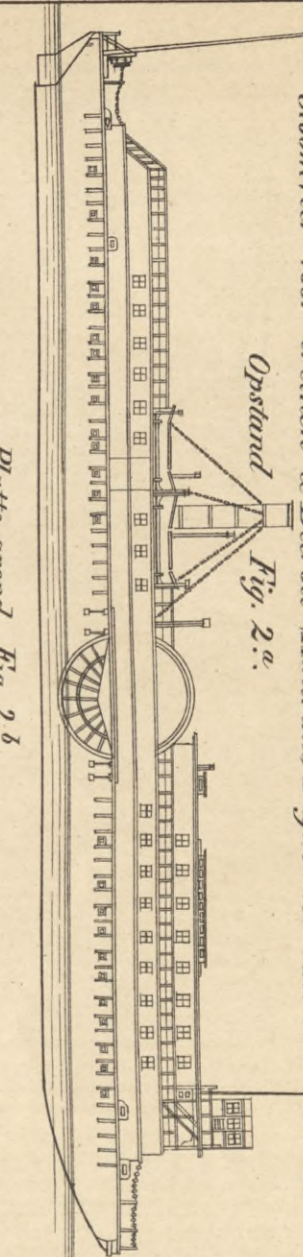
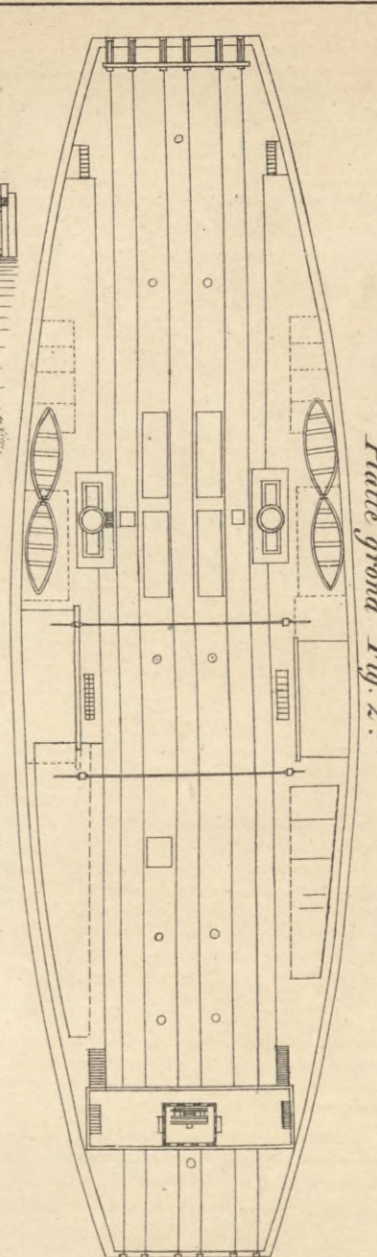

Stoomveer voor treinen te Detroit (Amerika) Fig. 2. a, 2. b (zie ook Pl. 48)

Fig. 1.<sup>b</sup>-1.<sup>c</sup> :  $\frac{1}{600}$ .

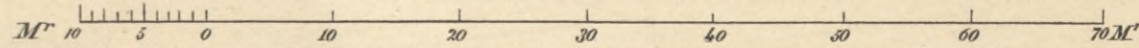
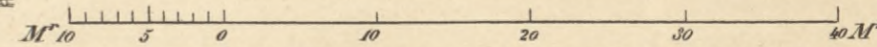
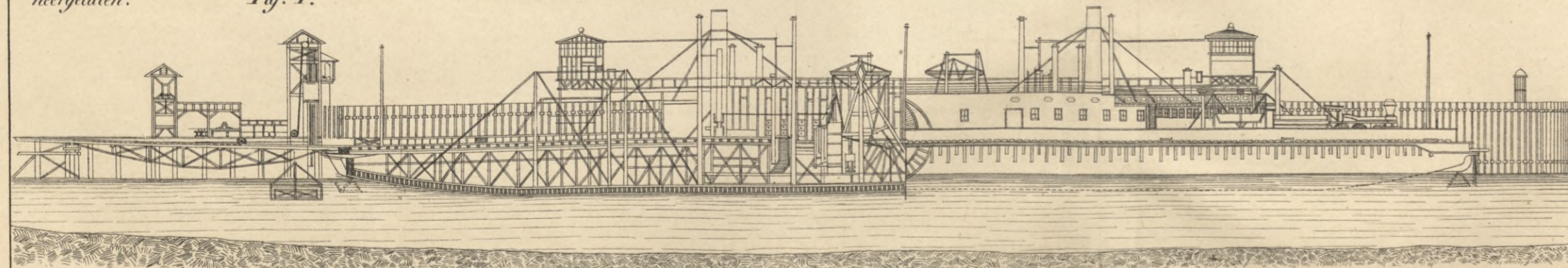

Fig. 2. a, 2. b :  $\frac{1}{500}$ .



Langsdoorsnede met de beweegbare klep neergelaten. Fig. 1.<sup>c</sup>



Langsdoorsnede met de beweegbare klep opgehaald. Fig. 1.<sup>d</sup>

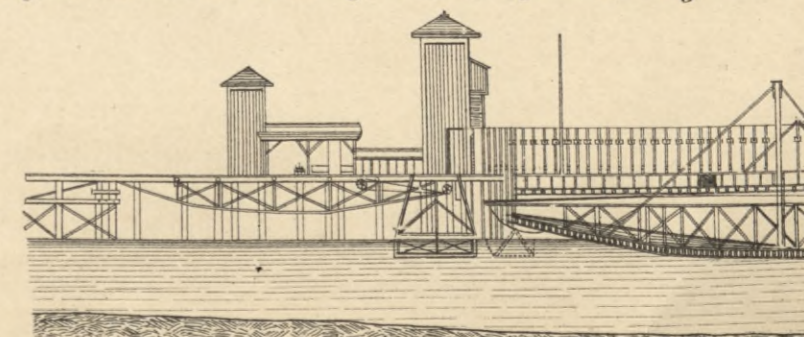





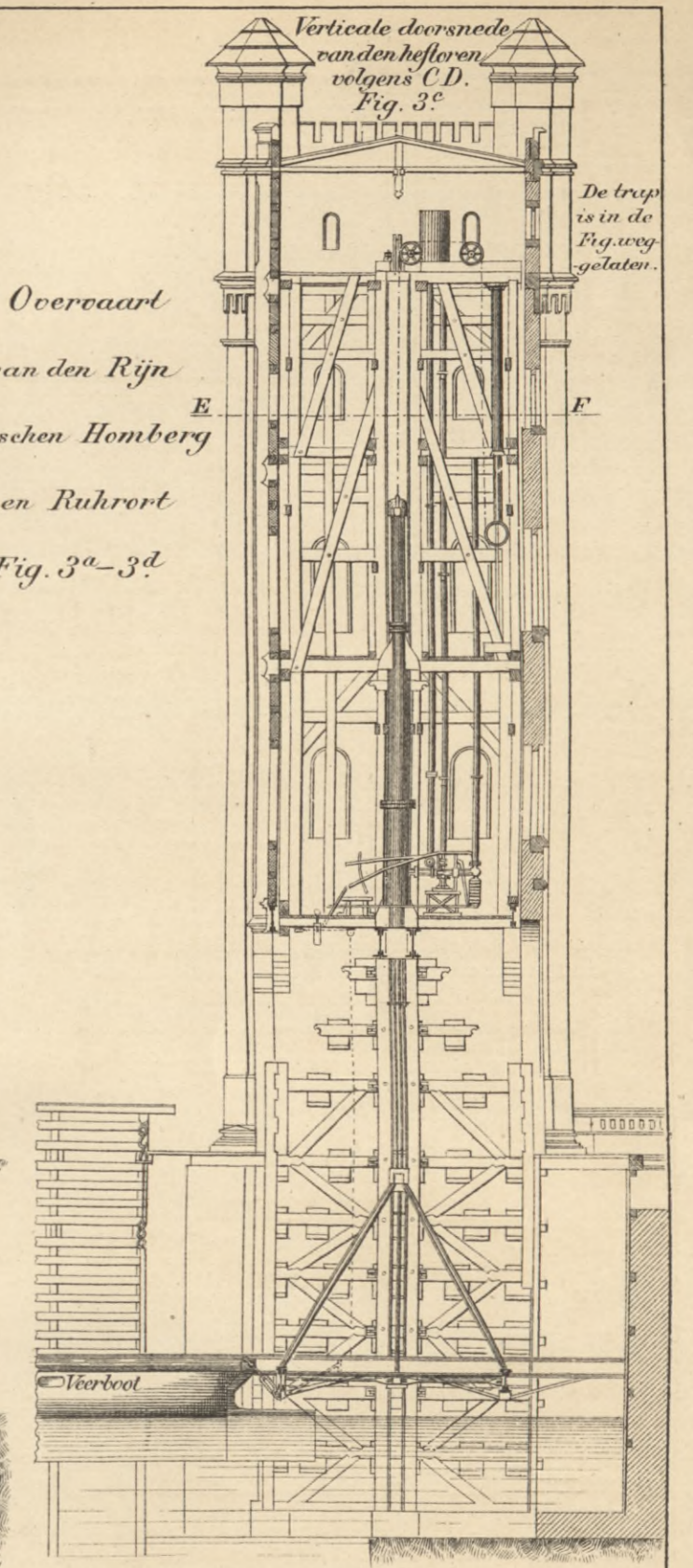
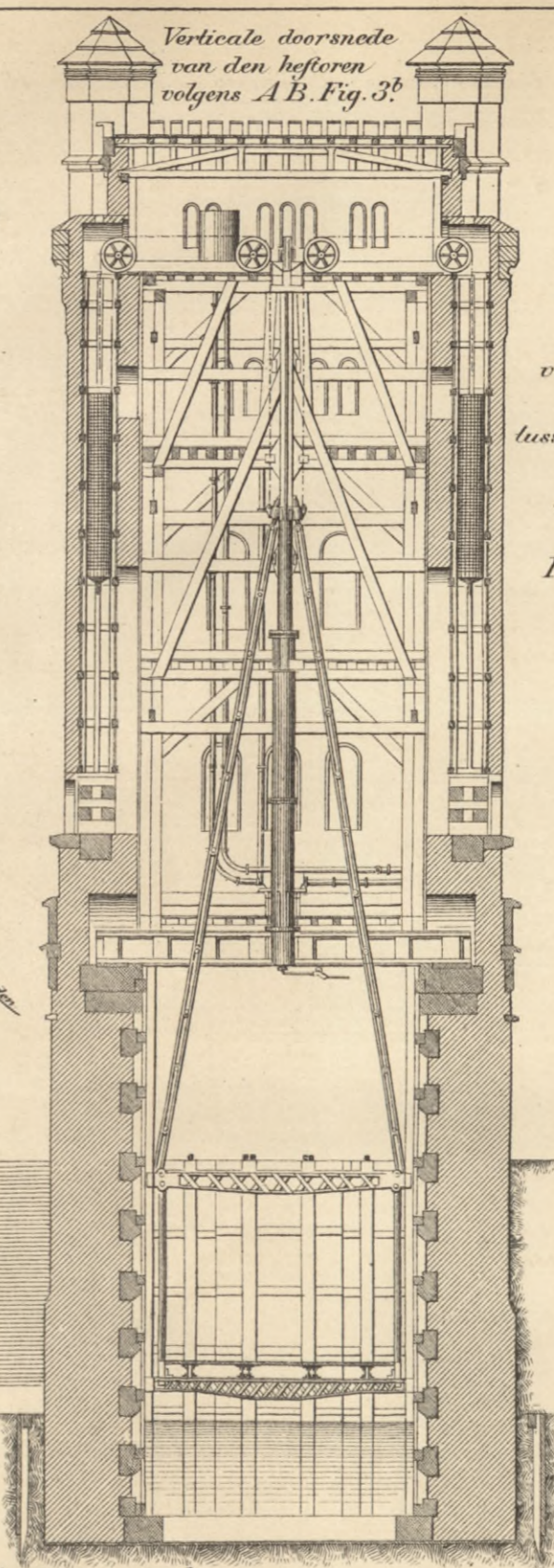
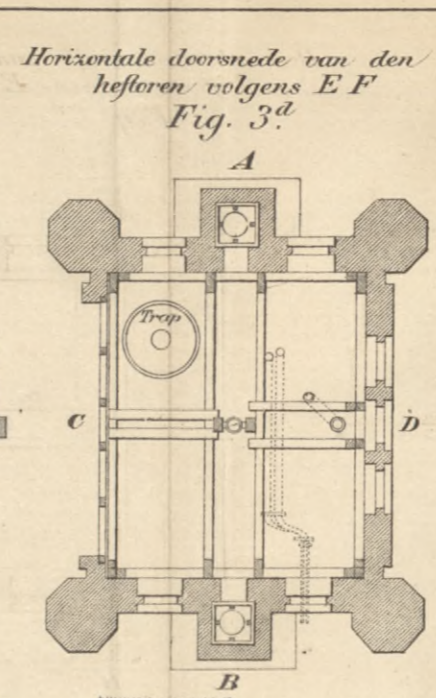
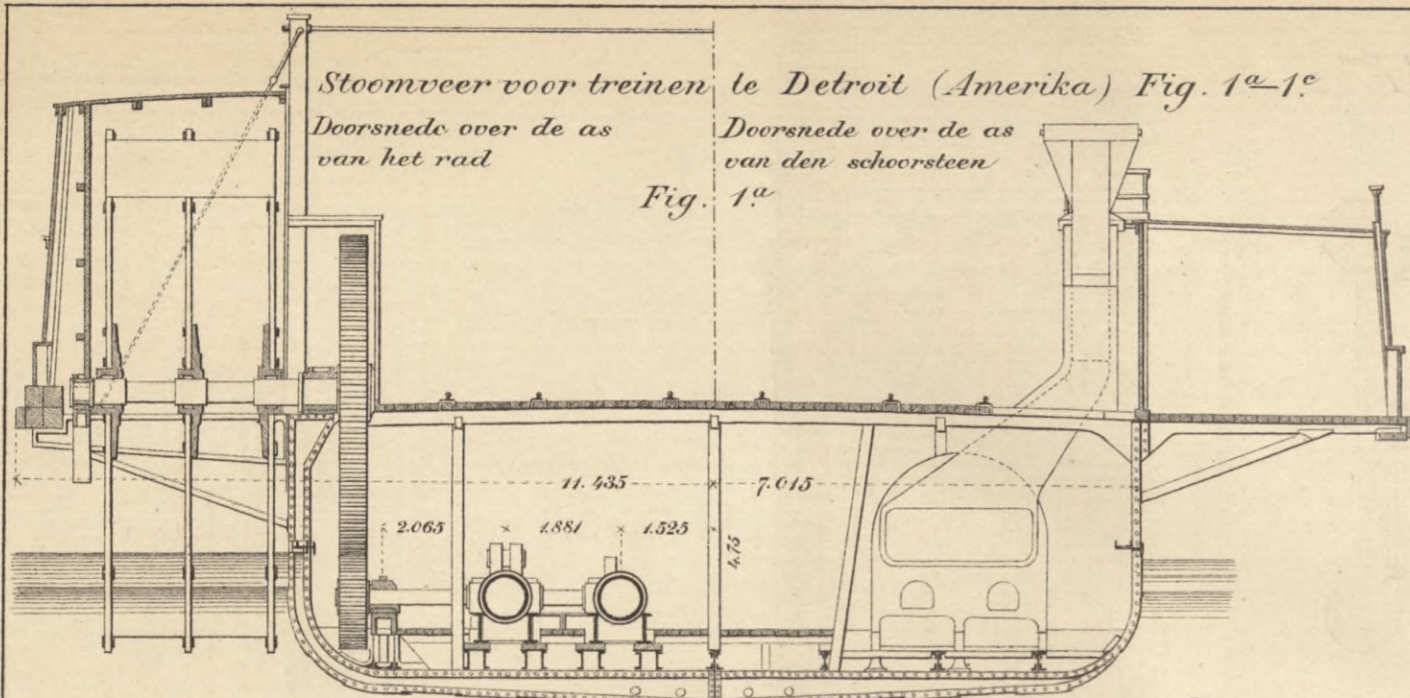

Overvaart van den Rijn tusschen Homberg en Ruhrort Fig. 3<sup>a</sup>-3<sup>d</sup>

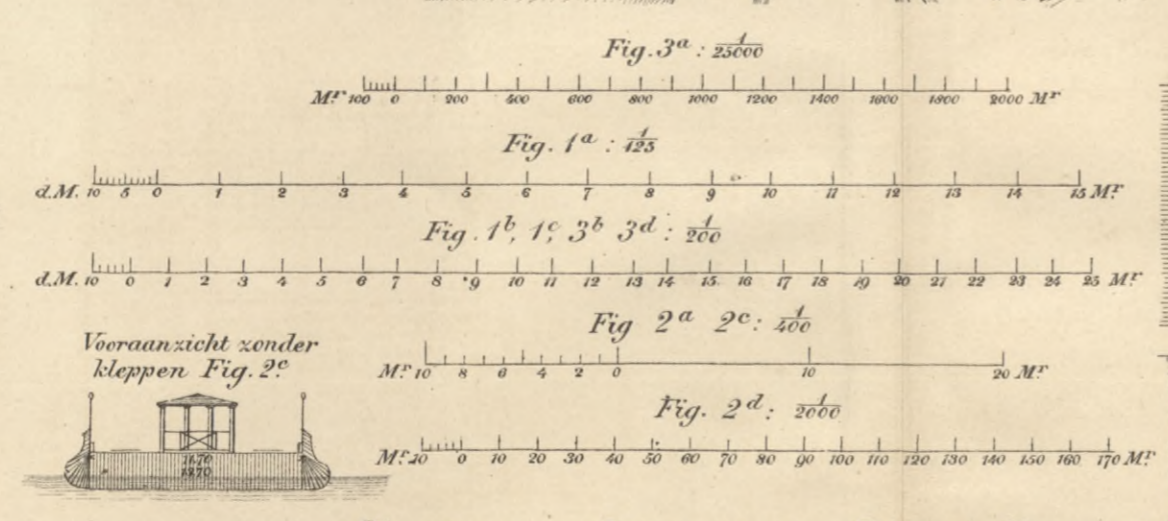
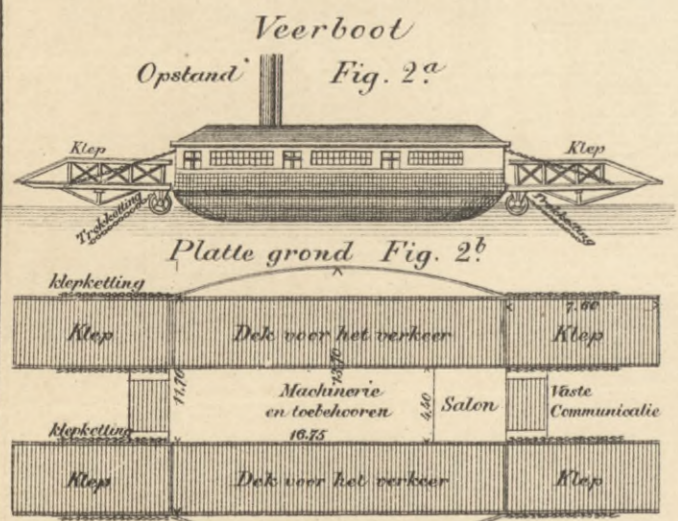
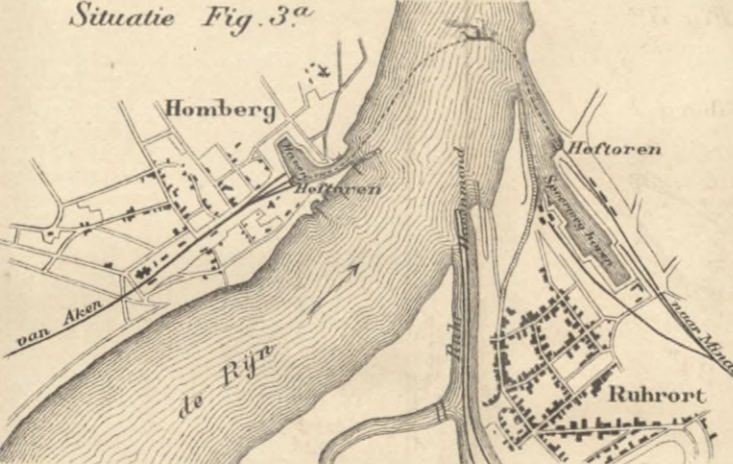
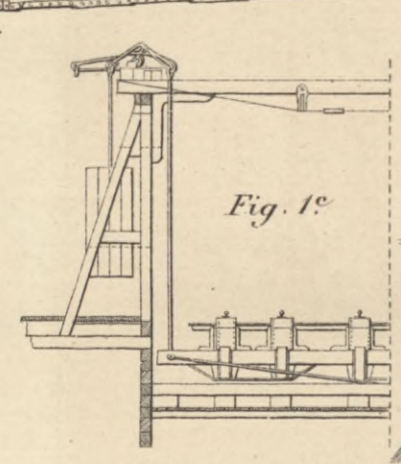
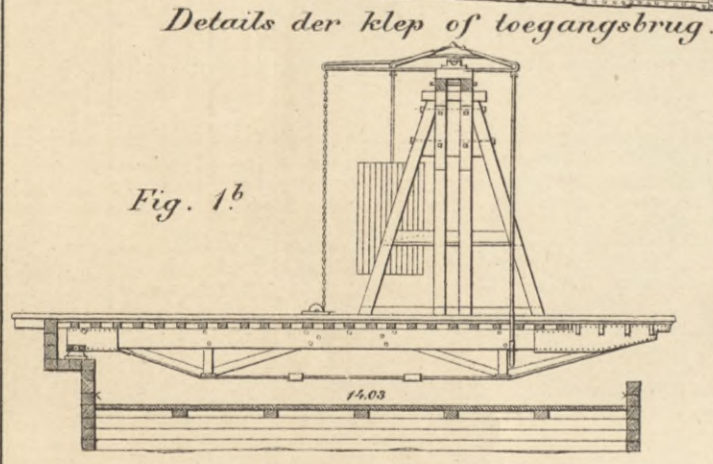



S. 61



20900







POLITECHNIKA KRAKOWSKA  
BIBLIOTEKA GŁÓWNA

Biblioteka Politechniki Krakowskiej



IV-300957

Kdn. 524, 13, IX, 54

Biblioteka Politechniki Krakowskiej



10000300861