





Biblioteka Politechniki Krakowskiej



100000299663



B 655.

x  
goh





II 8182

L. Barret

Note sur l'aménagement des ponts  
de commerce

Marseille, Soc. Scientif. 1875

2 vol. Text + atlas

Akc. Nr. 1501/52

449.131



Fig. 5

Docks S<sup>te</sup> Catherine.  
(Londres.)

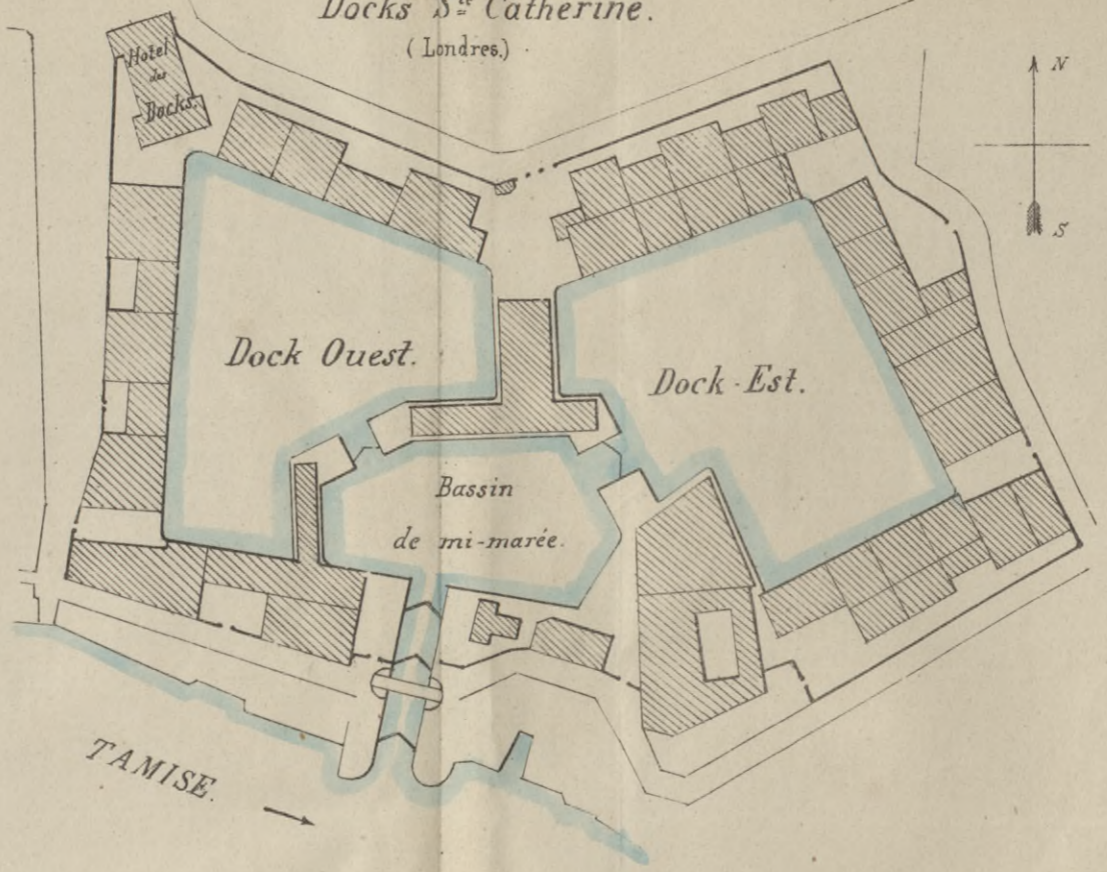

Fig. 6.

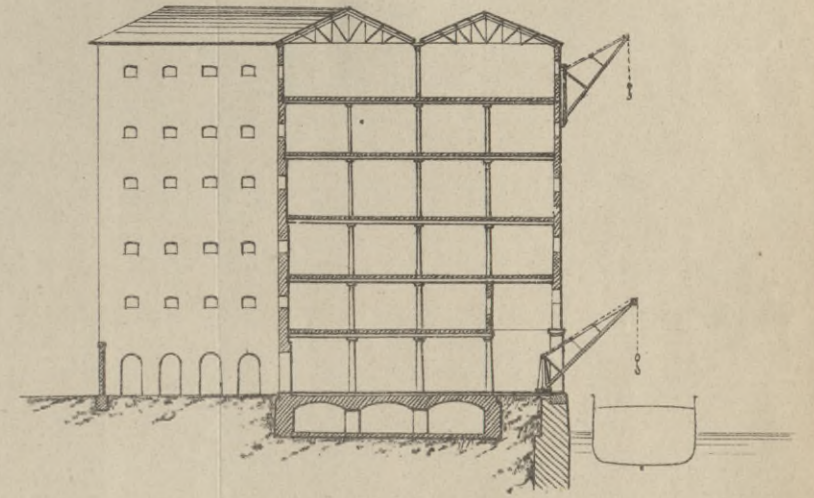

Fig. 4.

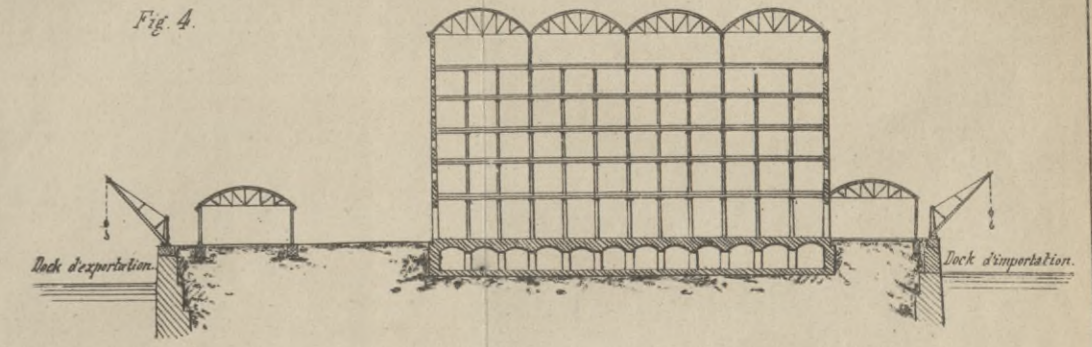

Fig. 3.

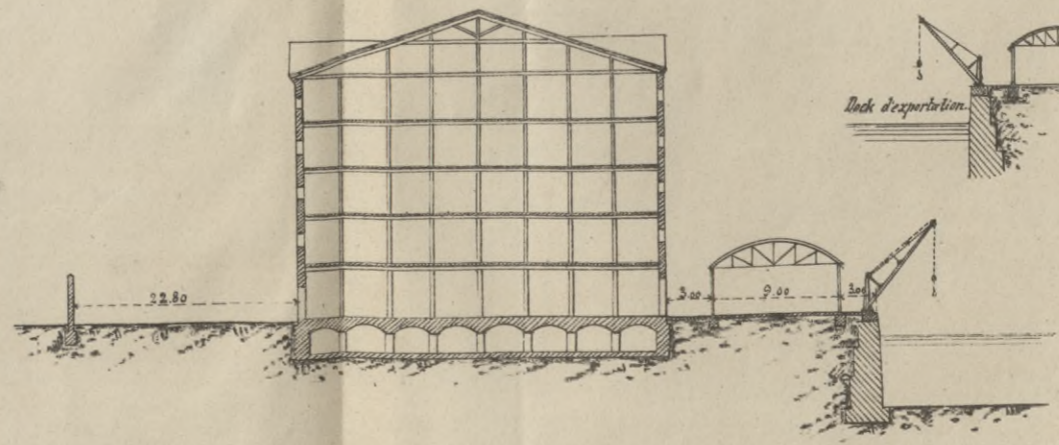

Fig. 1.

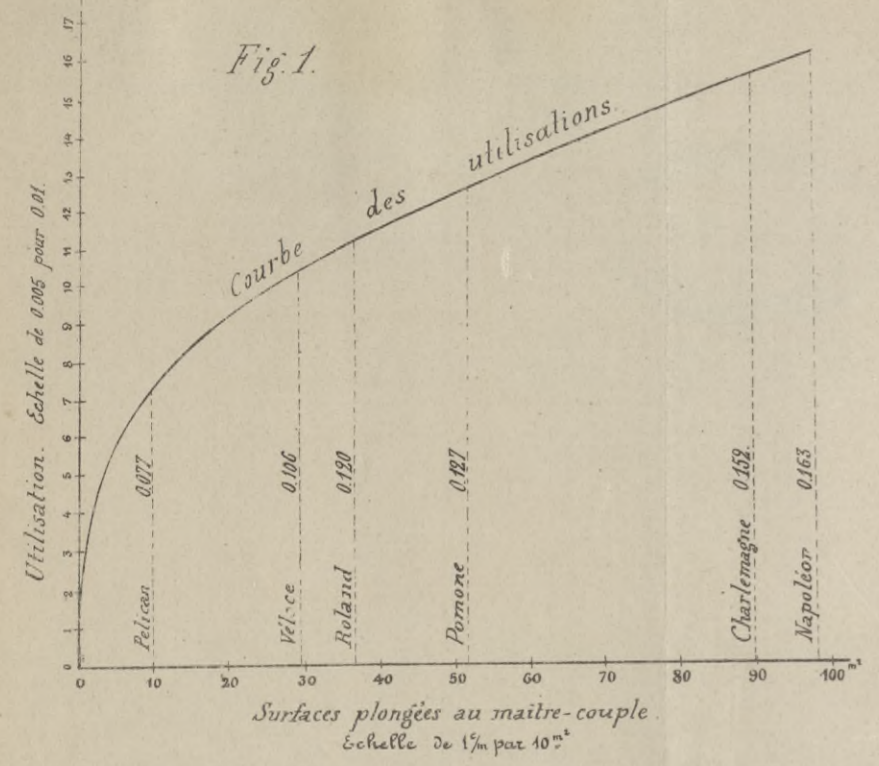
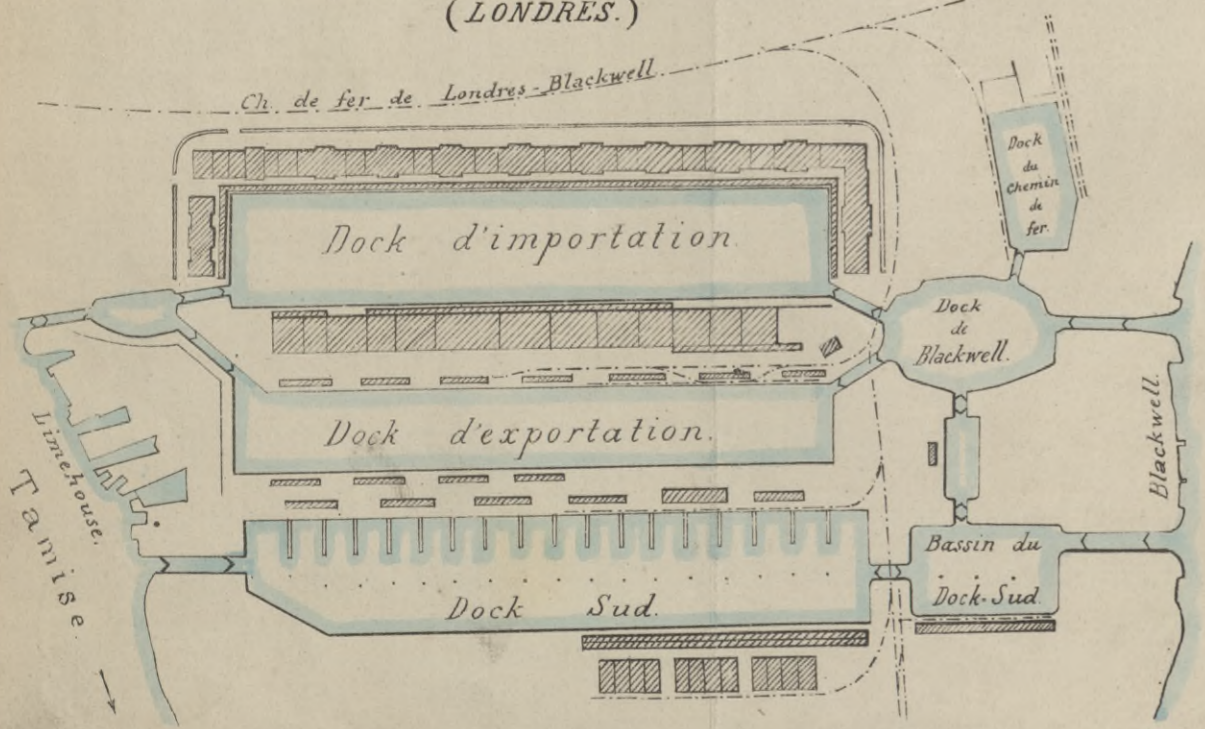

Fig. 2.

Docks des Indes-Occidentales.  
(LONDRES.)





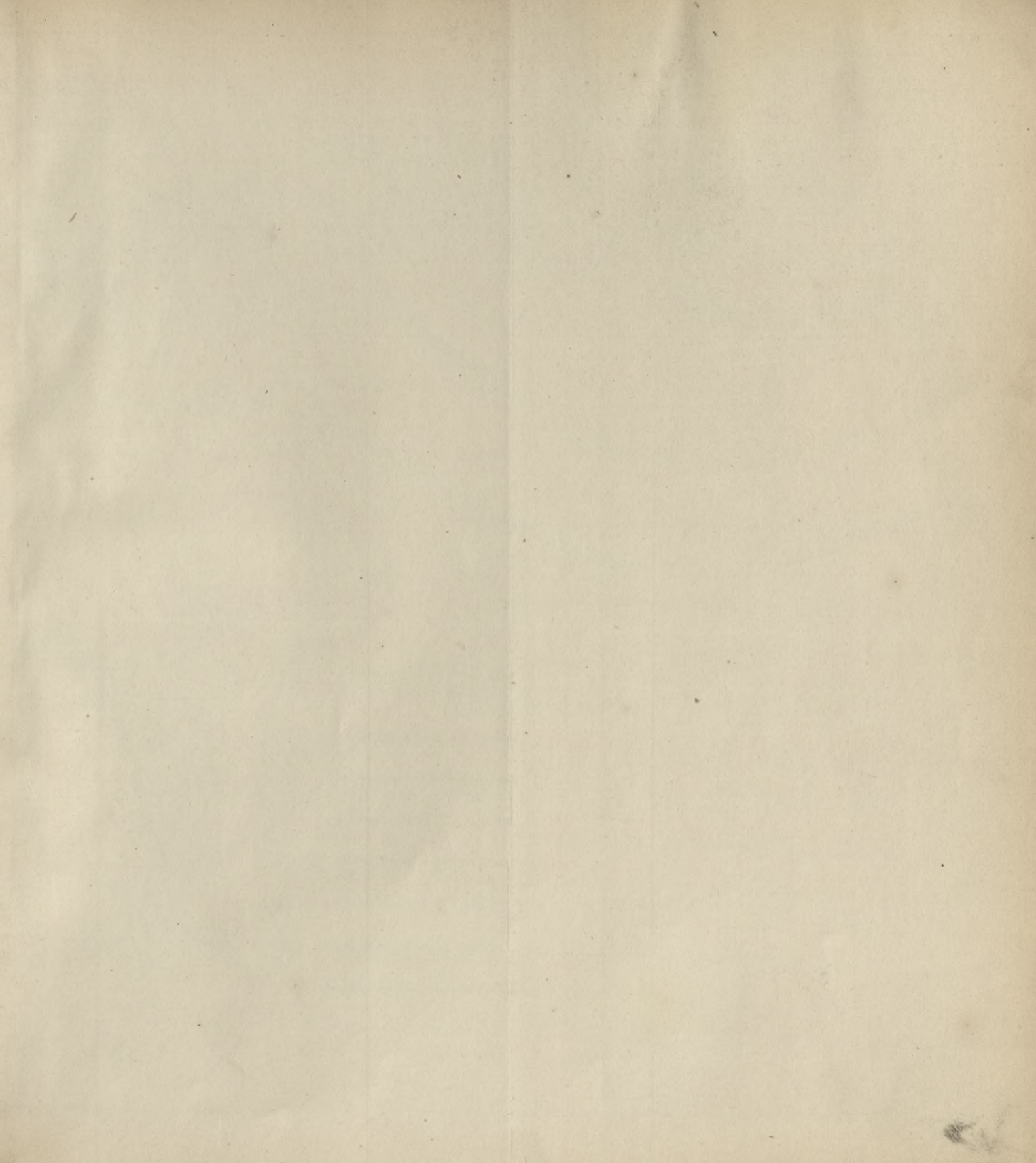



Fig. 7. Docks de Londres.

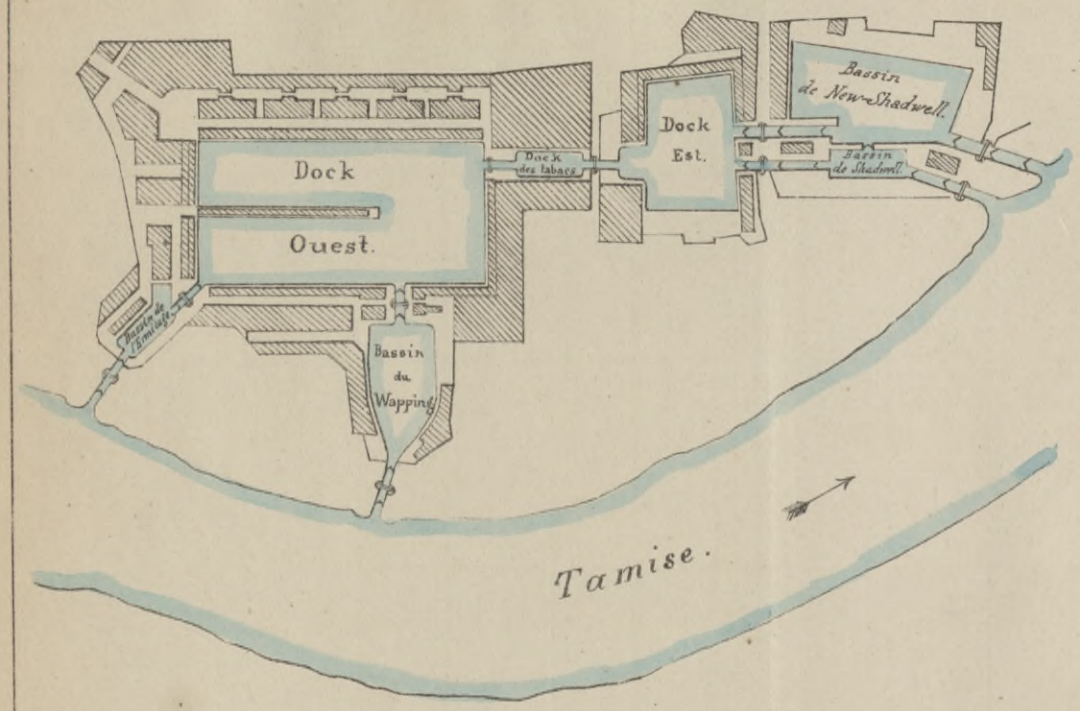

Fig. 9. Docks du Commerce (Londres.)

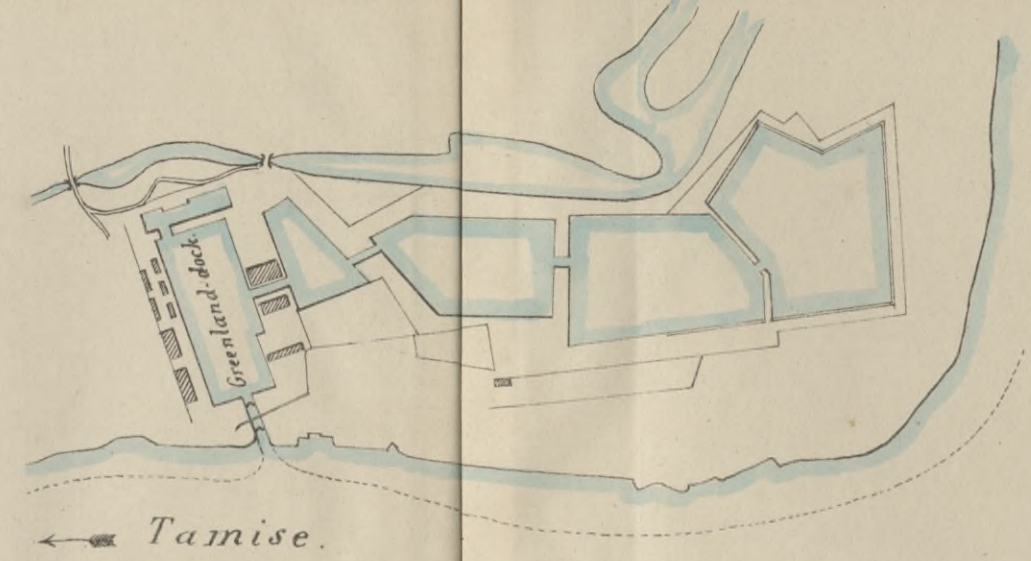

Fig. 8.

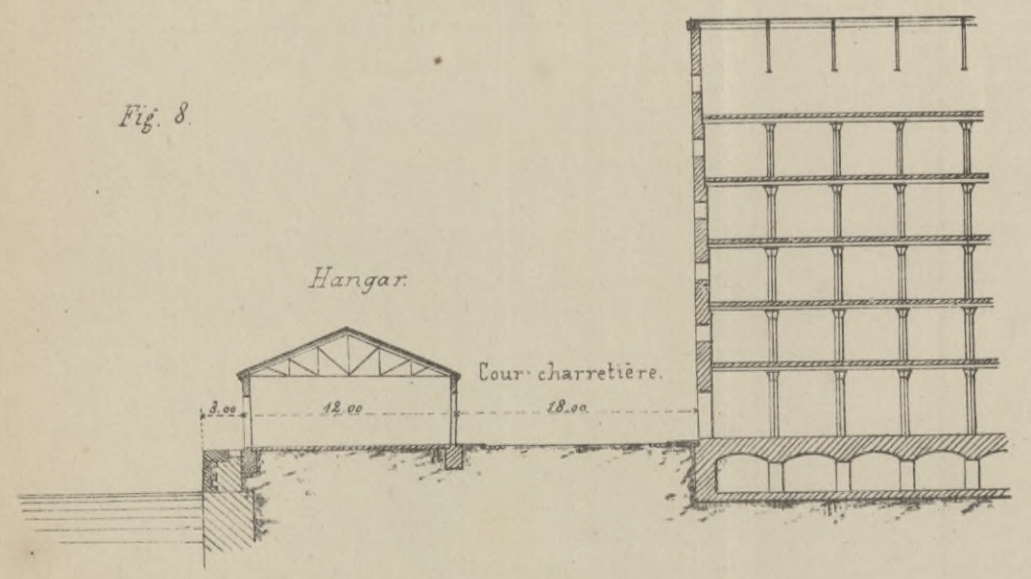

Fig. 10.

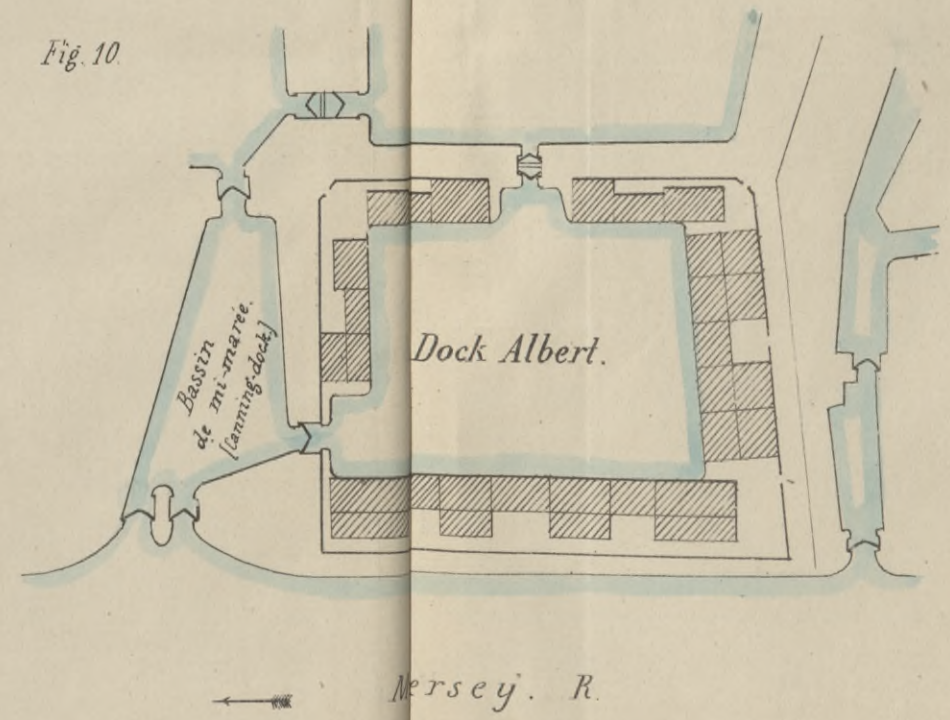

Fig. 11.

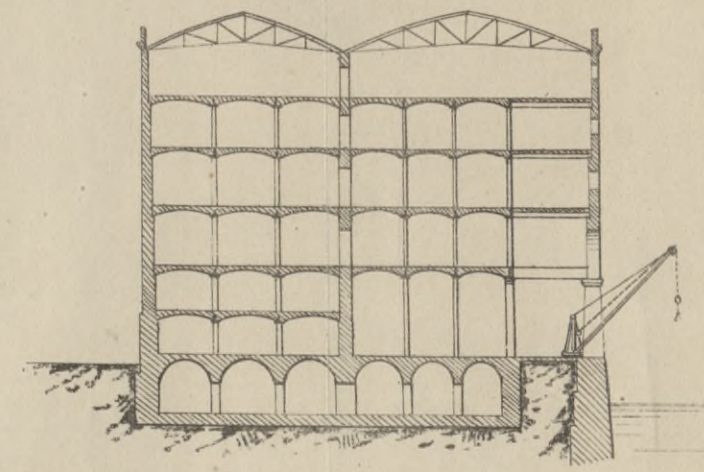





Fig. 12. Docks de Marseille.

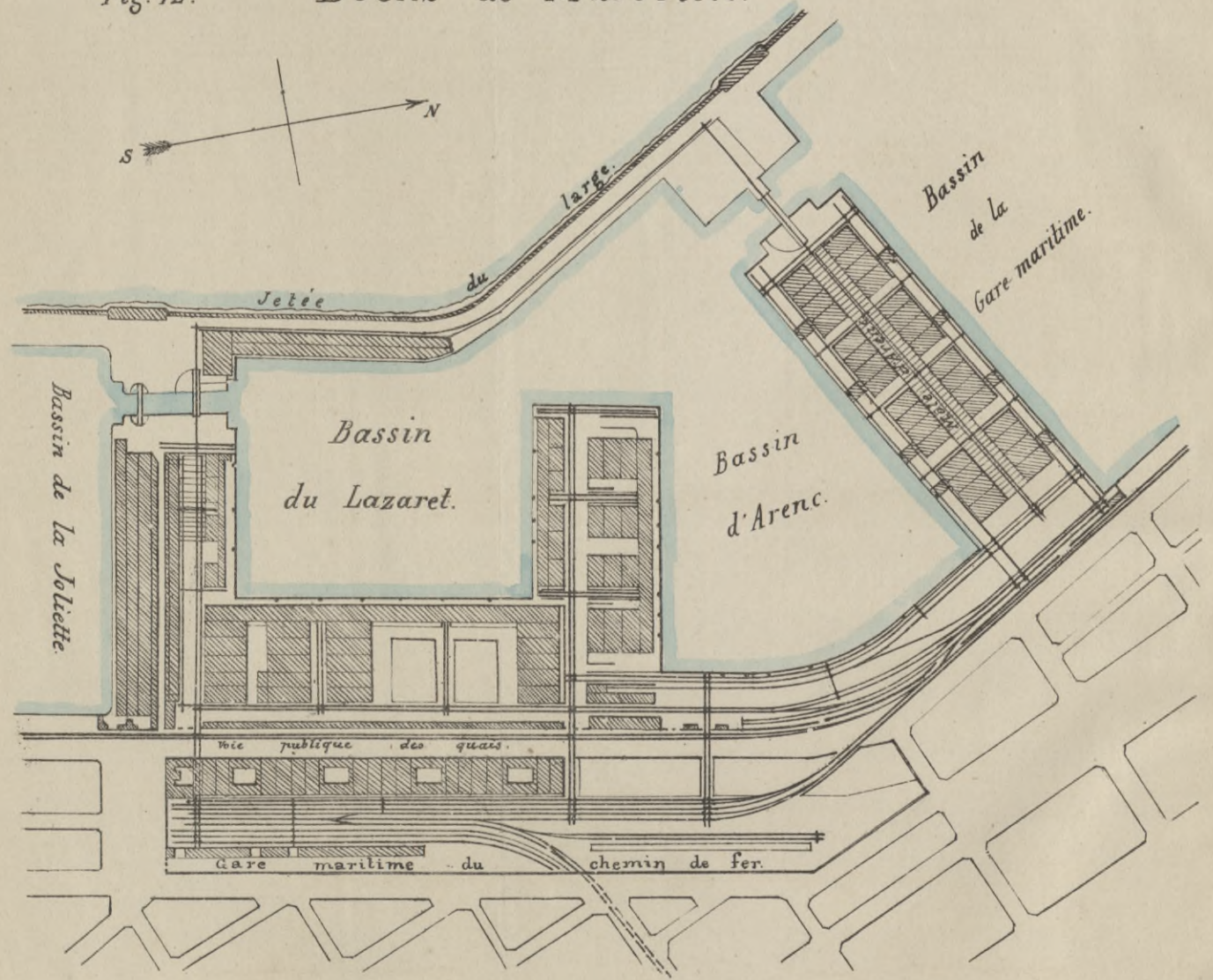

Fig. 13.

Digue extérieure.

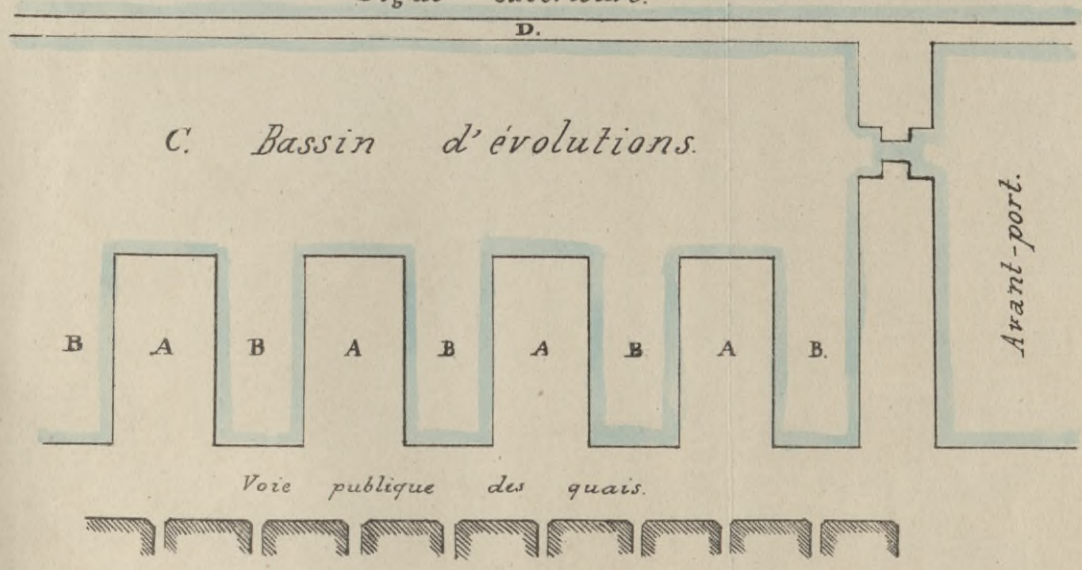

Fig. 14.

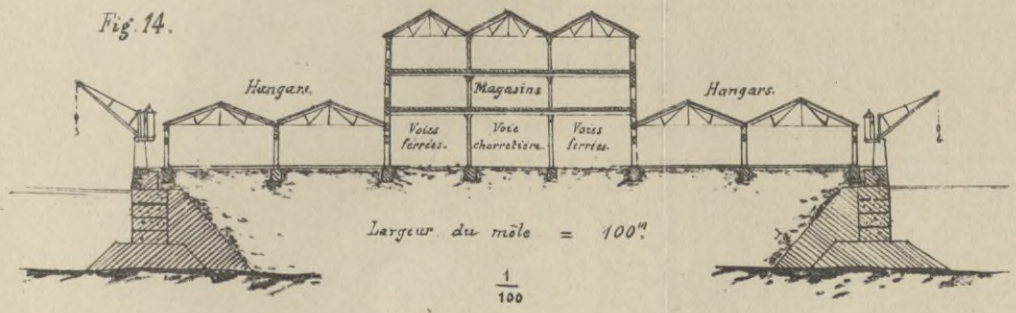





Fig. 15.

Plan.

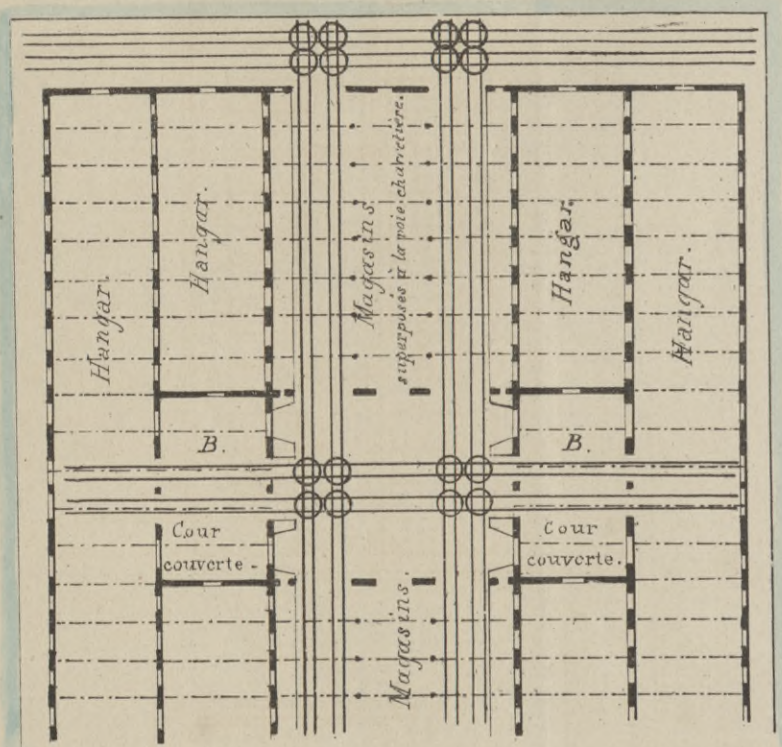
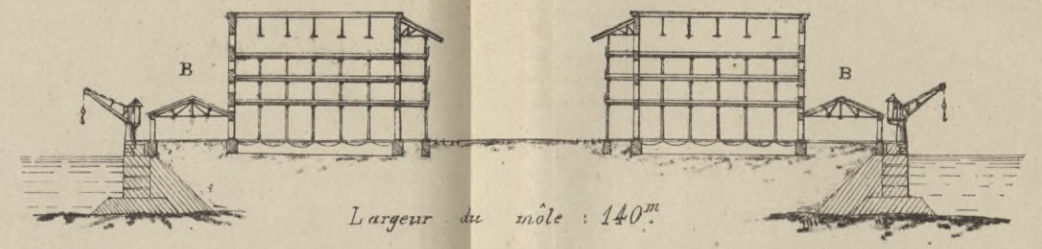

Fig. 16.



Plan.

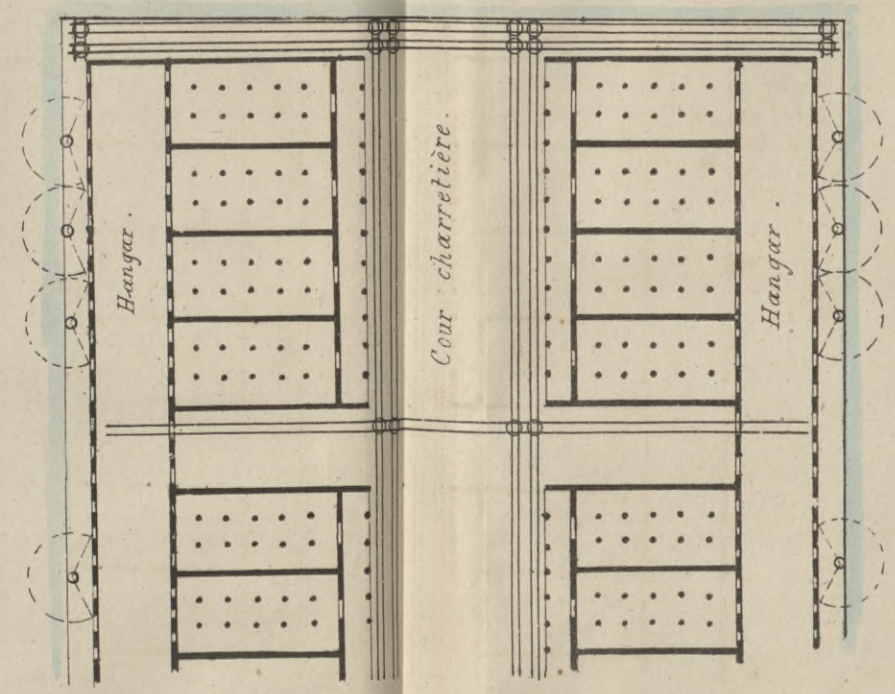

Fig. 19.

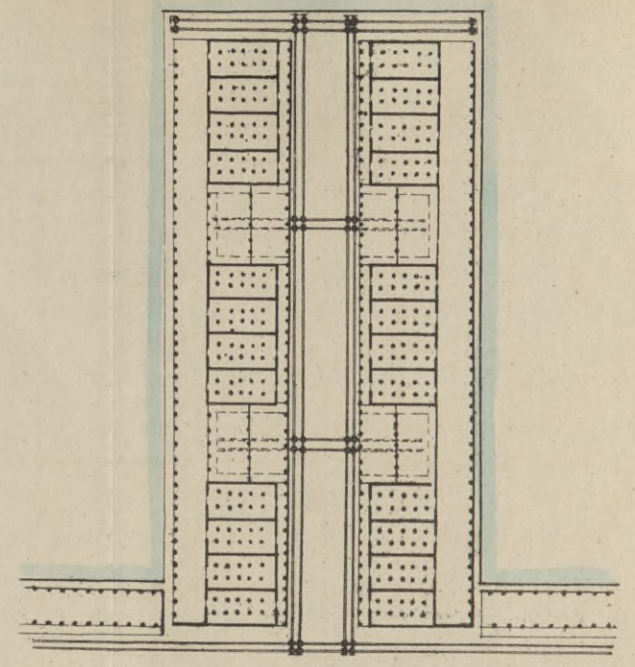

Fig. 20.

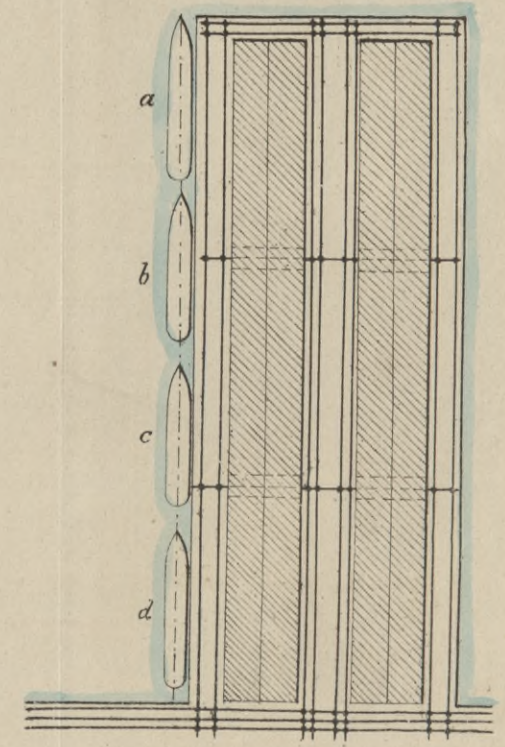

Fig. 17.

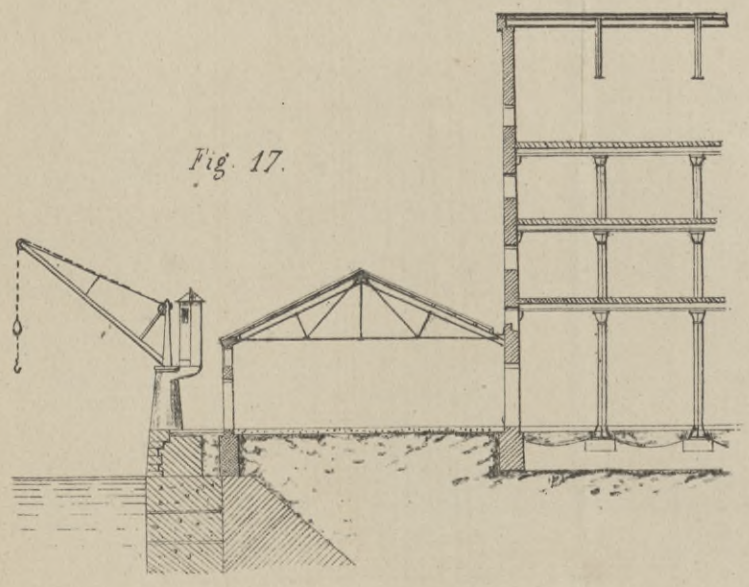

Fig. 18.

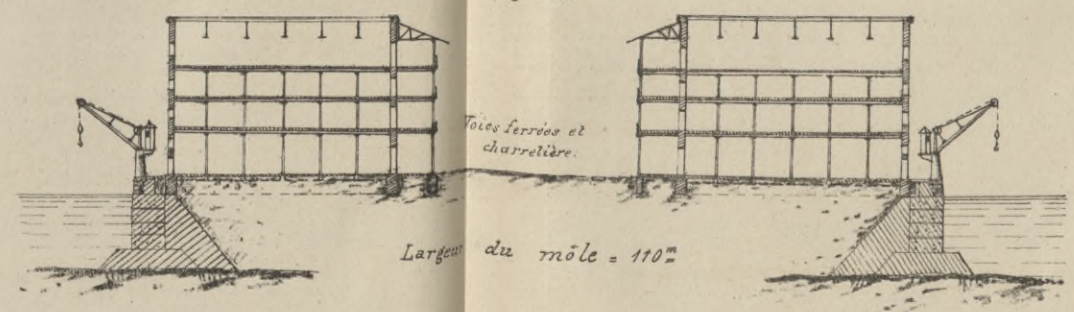
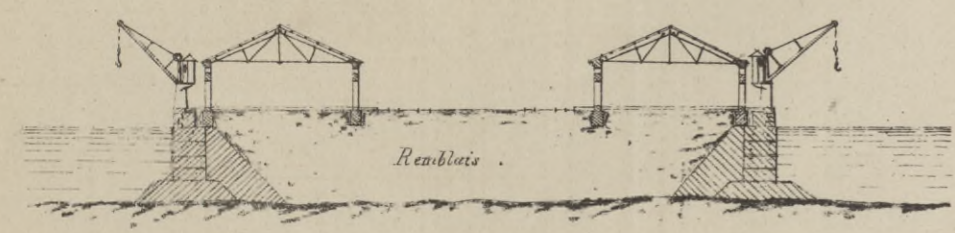





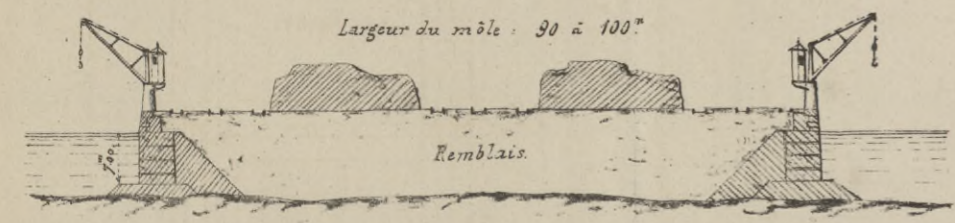

Fig. 21.



Largueur du môle = 80<sup>m</sup>

Fig. 22.



Largueur du môle : 90 à 100<sup>m</sup>

Plan.

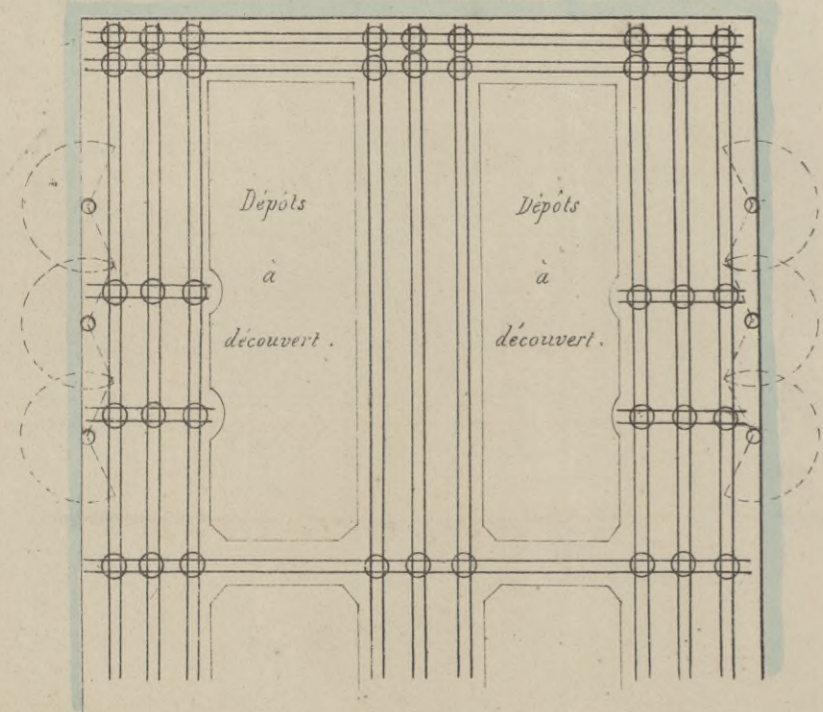
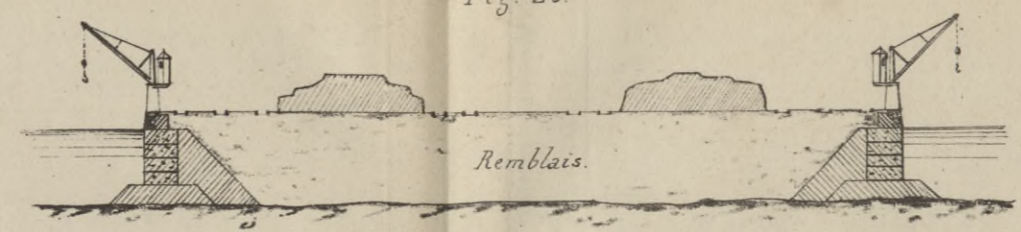

Fig. 23.



Plan.

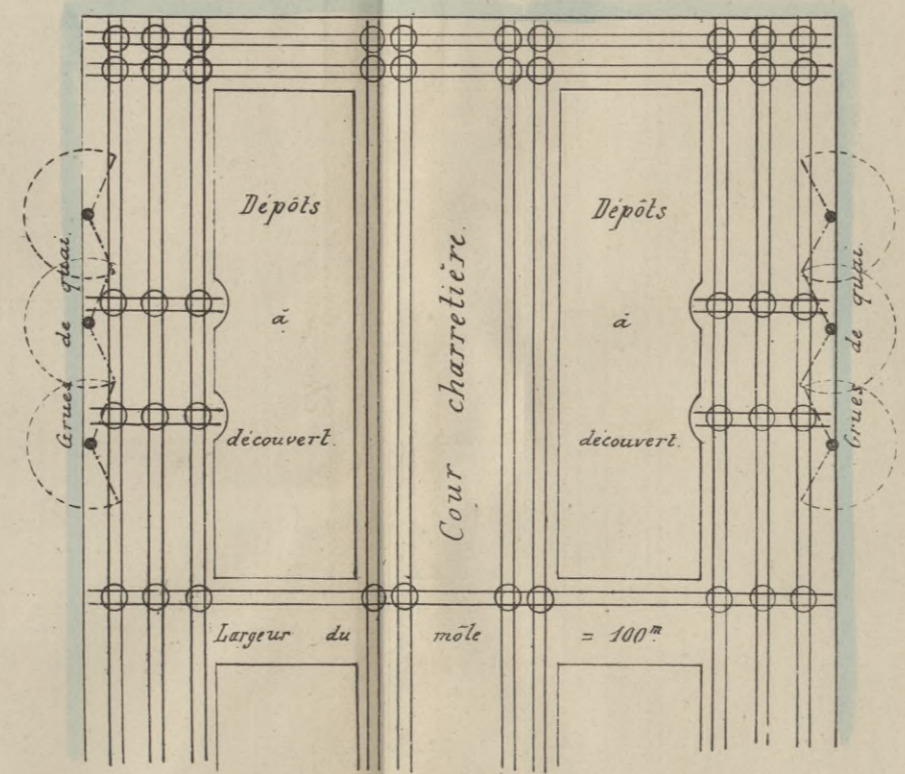

Fig. 25.

Profil du quai.

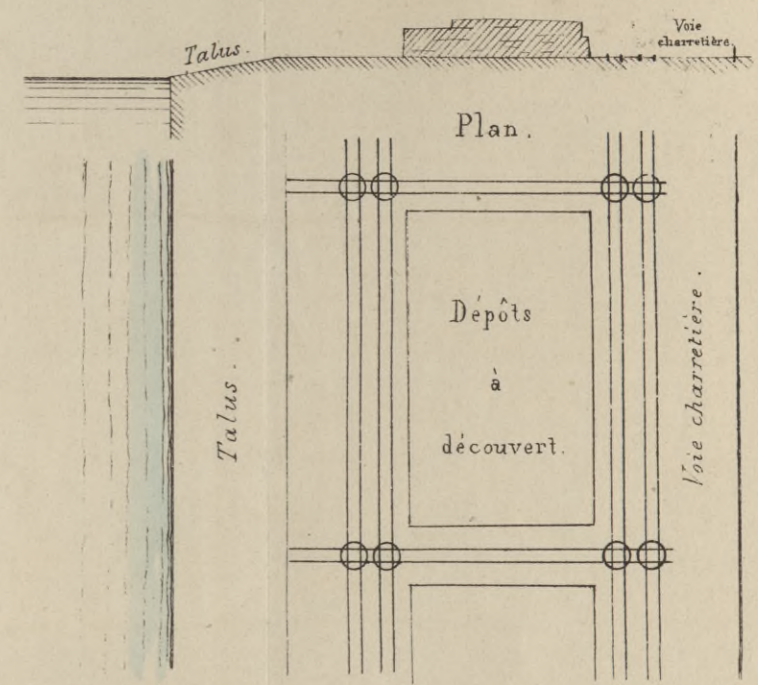

Fig. 24.

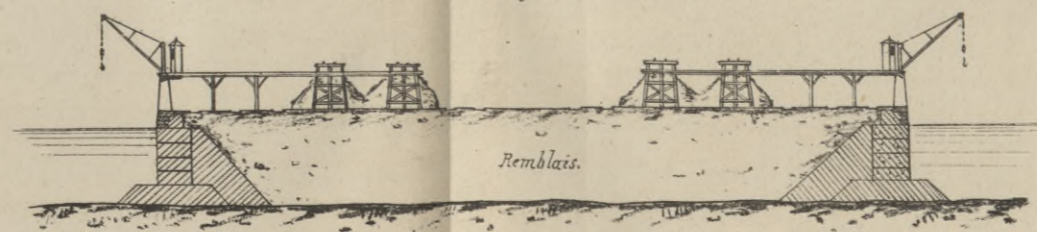

Fig. 26.

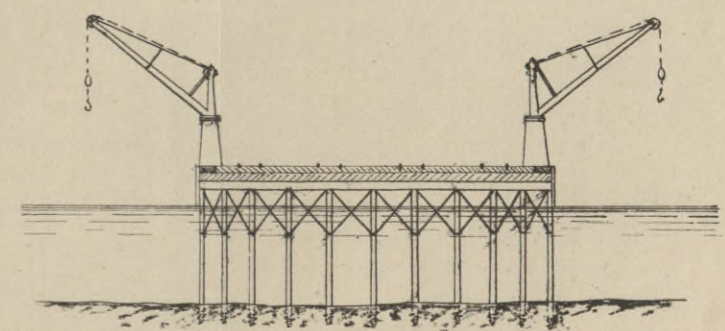





Fig. 27.

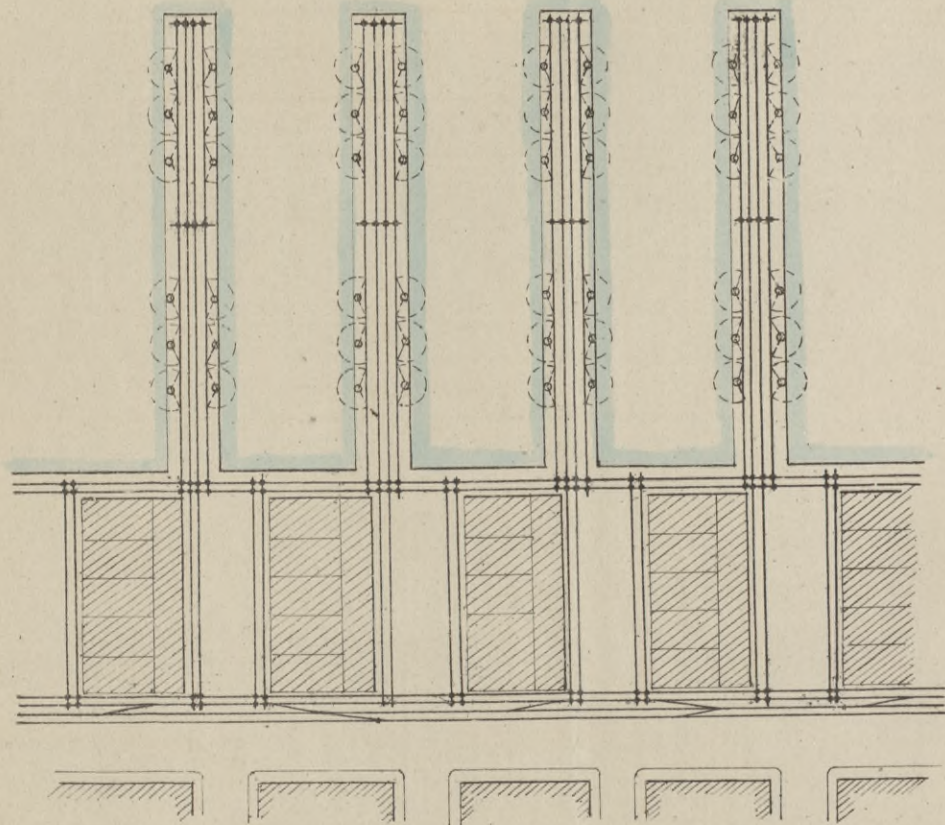

Fig. 28.

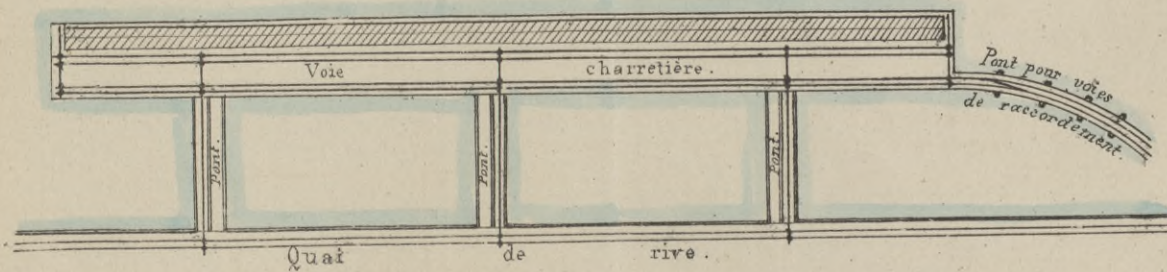

Fig. 29.

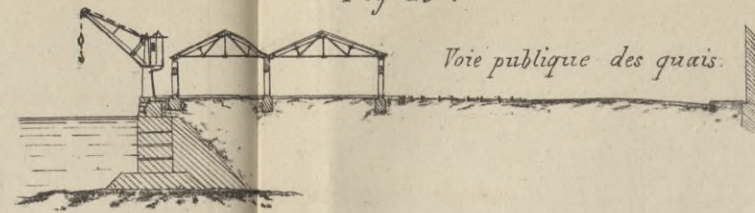

Fig. 30.

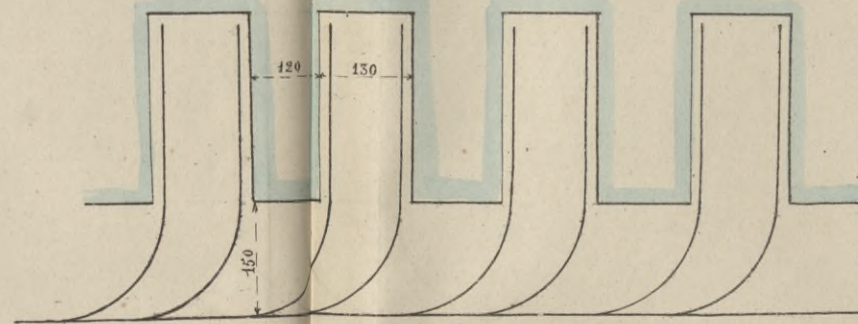

Fig. 31.

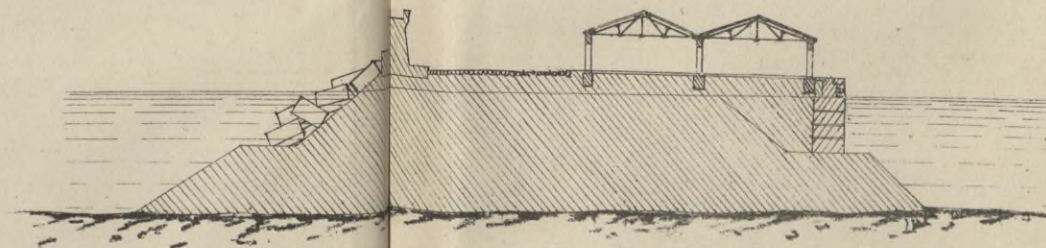

Fig. 32.

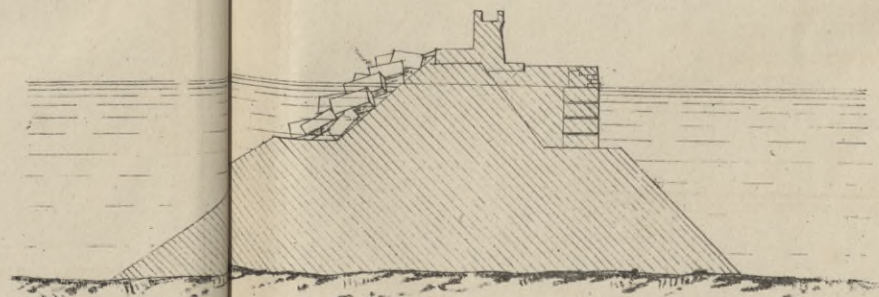

Fig. 33.

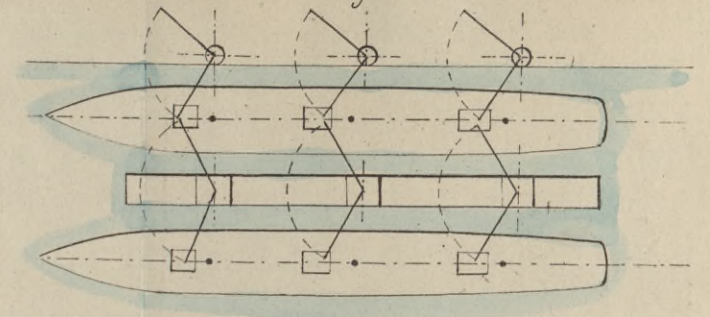

Fig. 34.

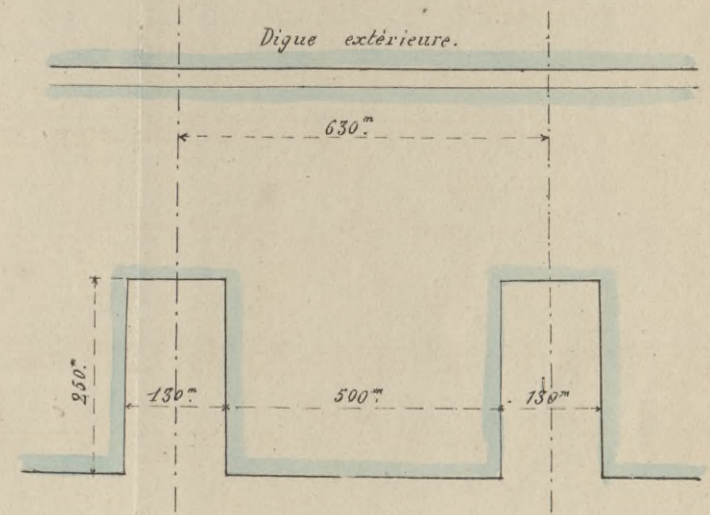

Fig. 35.

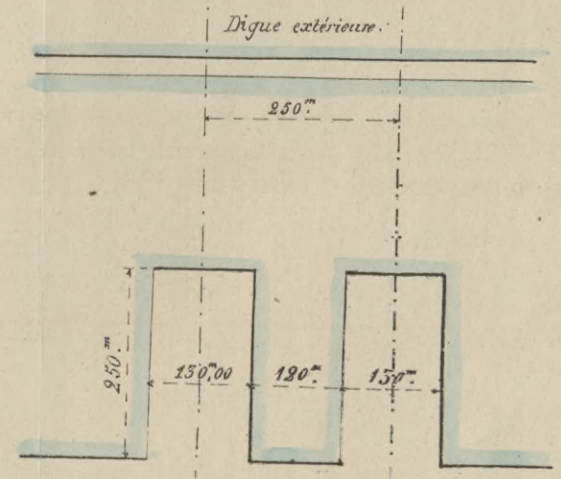





Fig. 36.

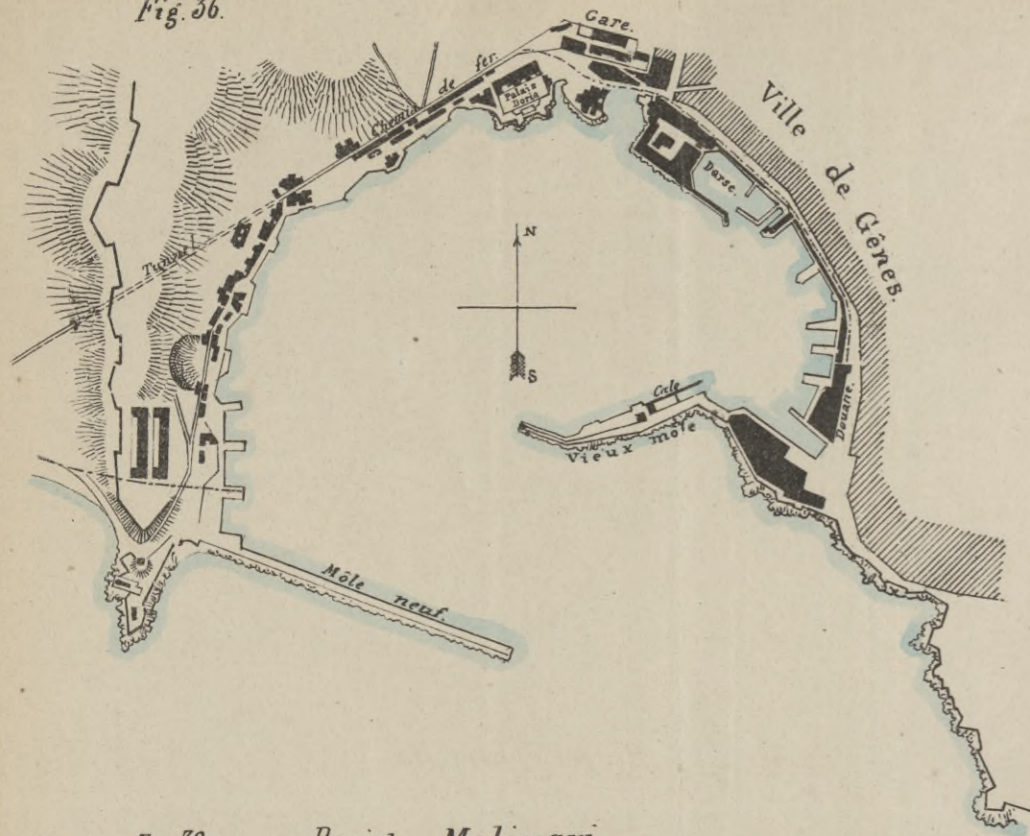

Fig. 37.

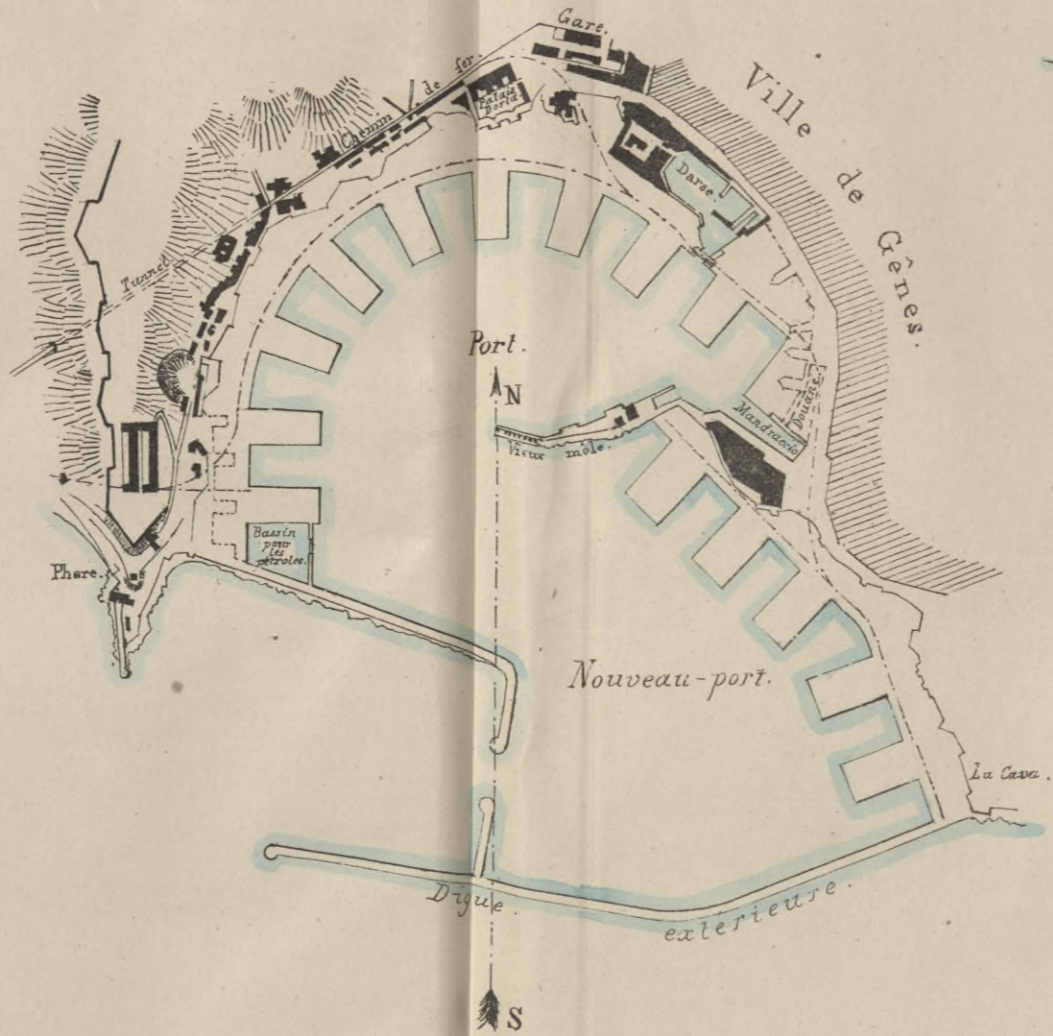

Fig. 38. *Projet Parodi.*

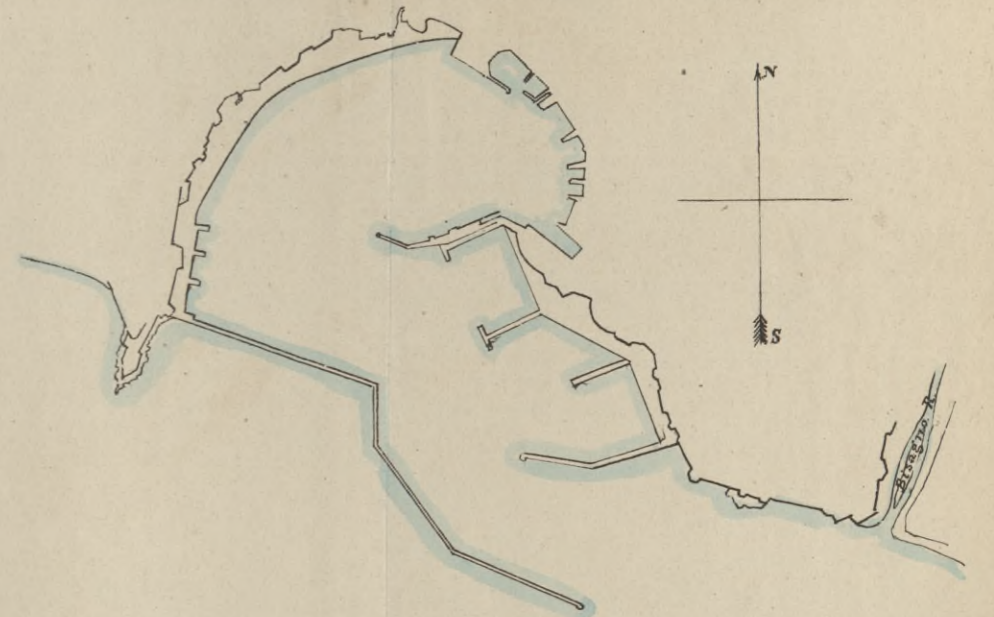

Fig. 39. *Projet Molinari.*

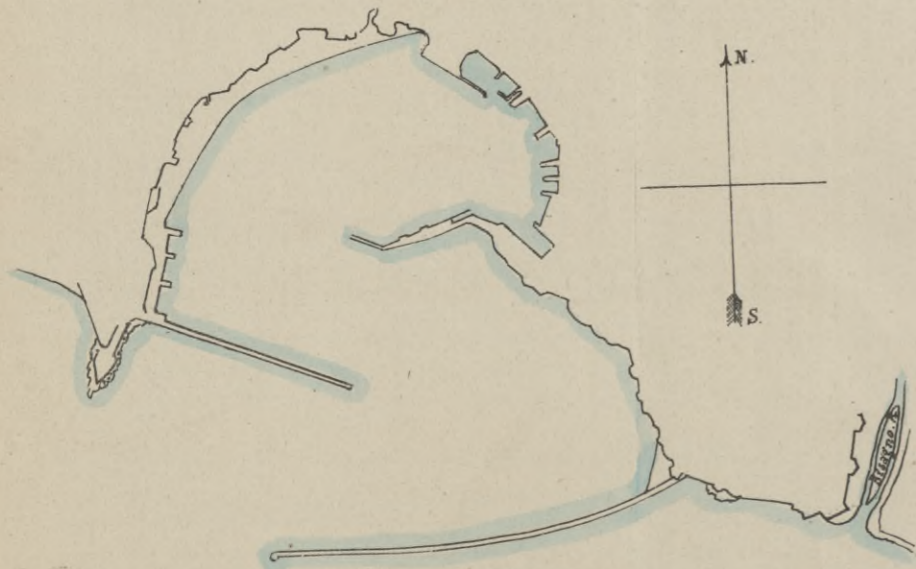

Fig. 40. *Projet Tortello.*

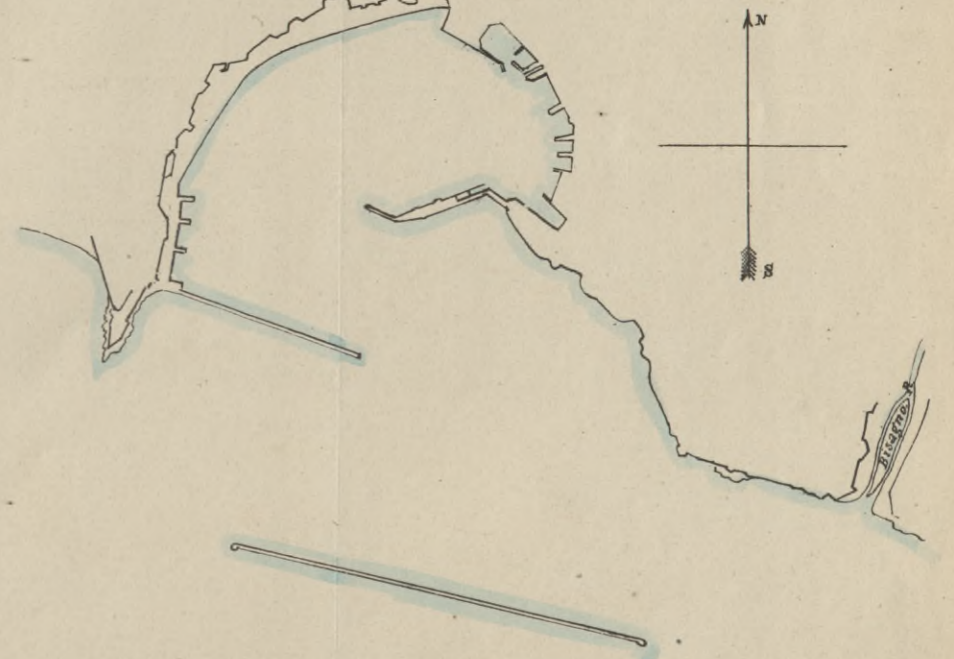







Fig. 42.

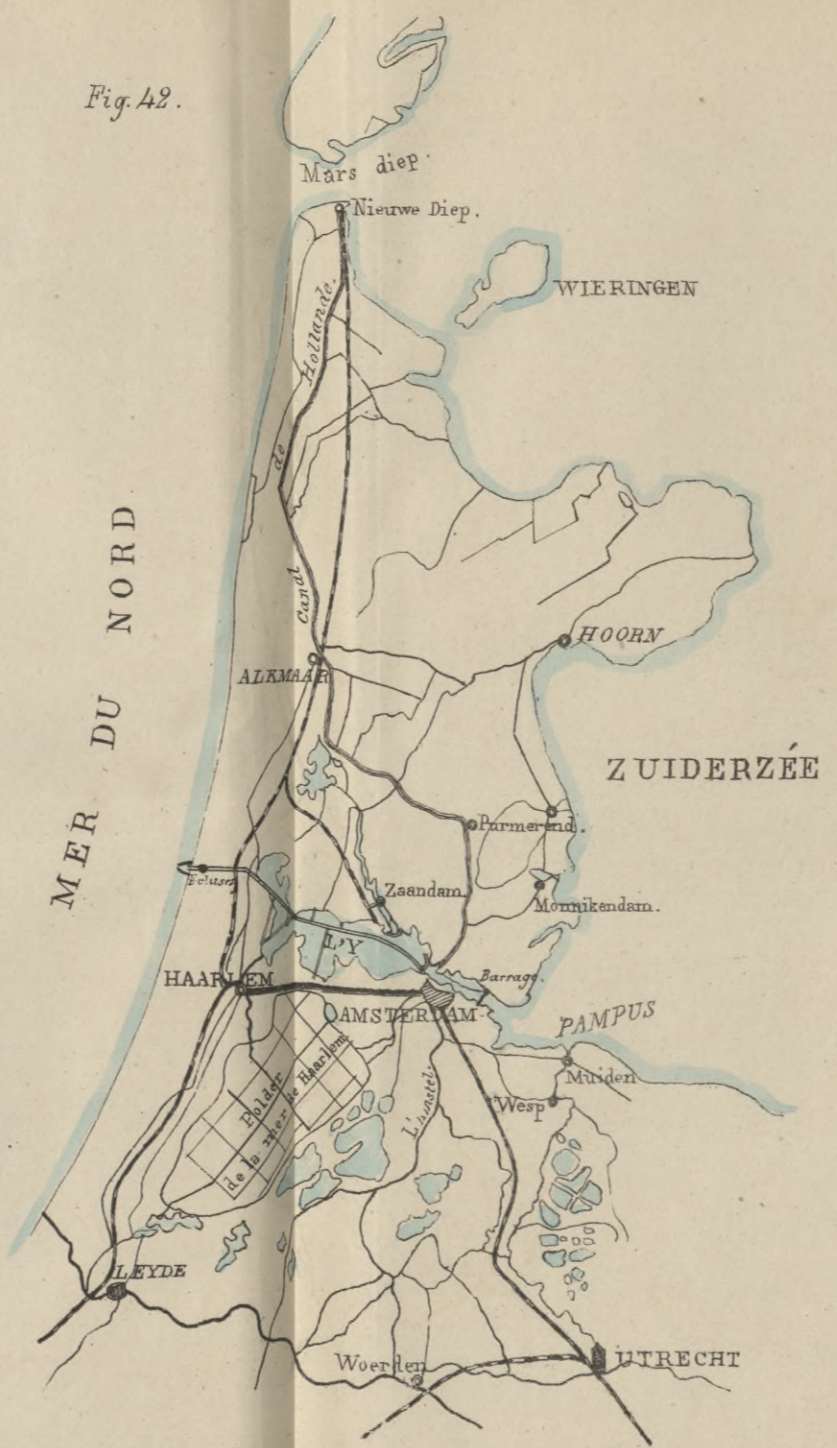

Fig. 41.



Fig. 43.

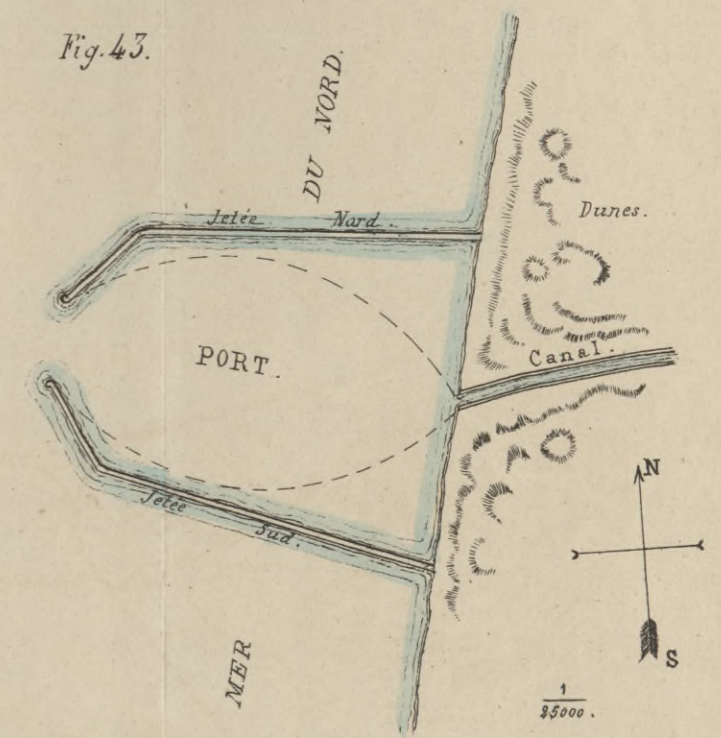





Fig. 44.

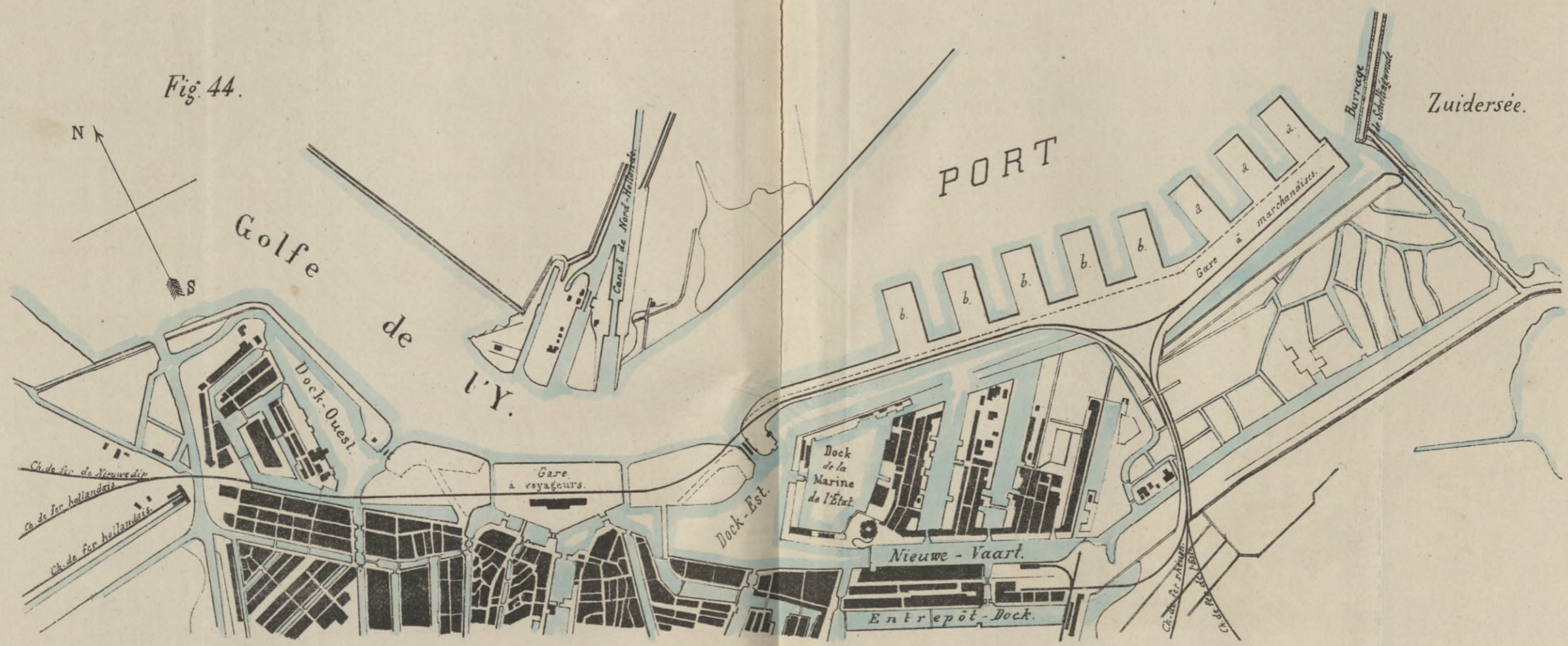







Fig. 45.

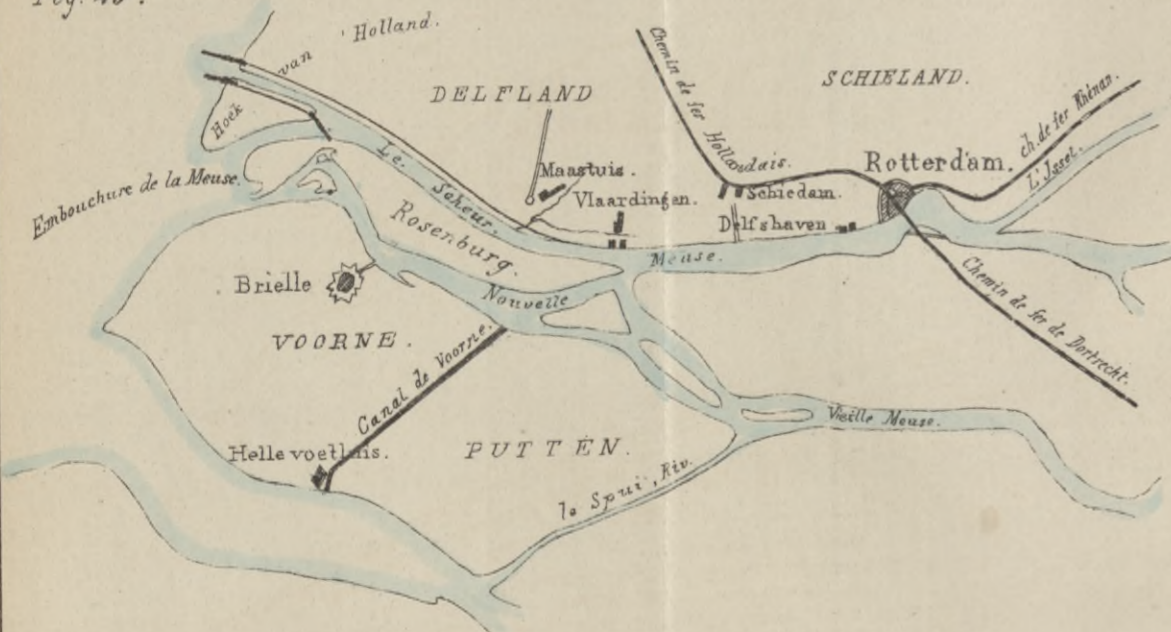

Fig. 46.

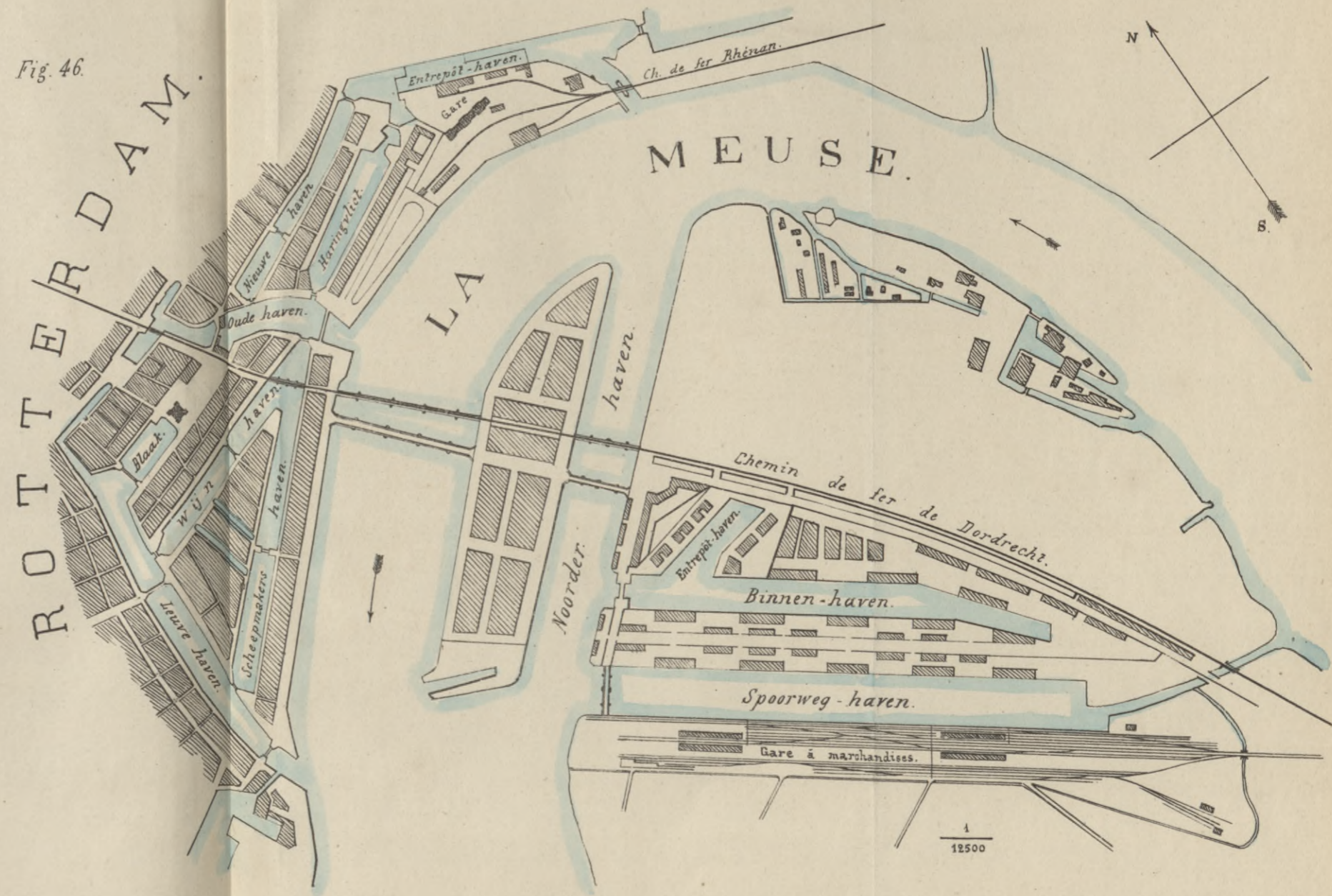





Fig. 47.

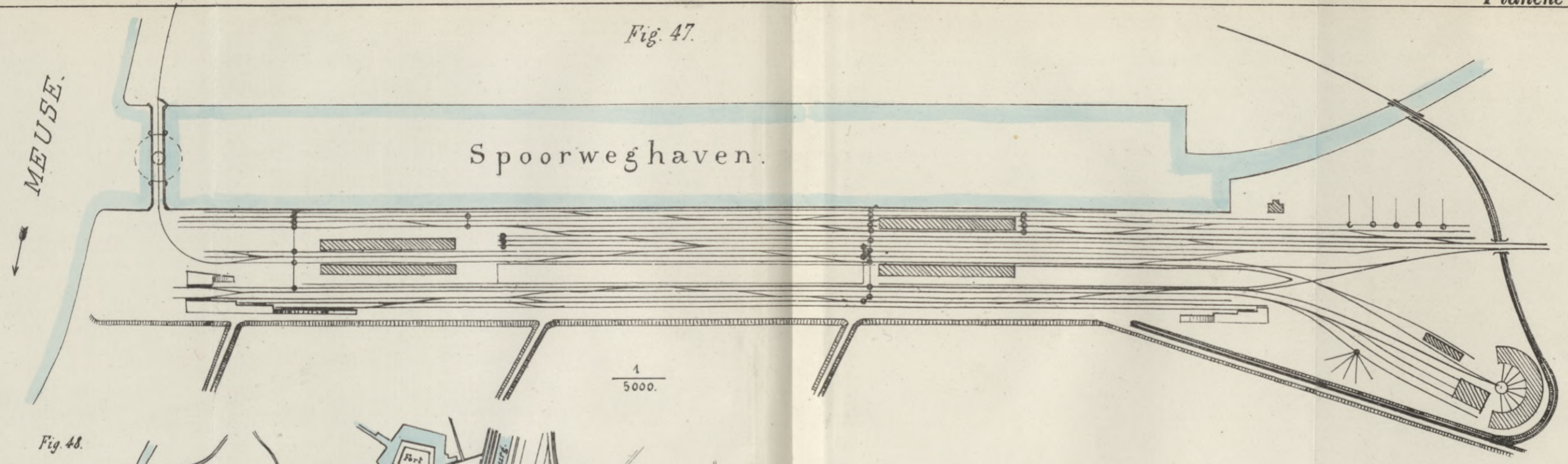

Fig. 48.

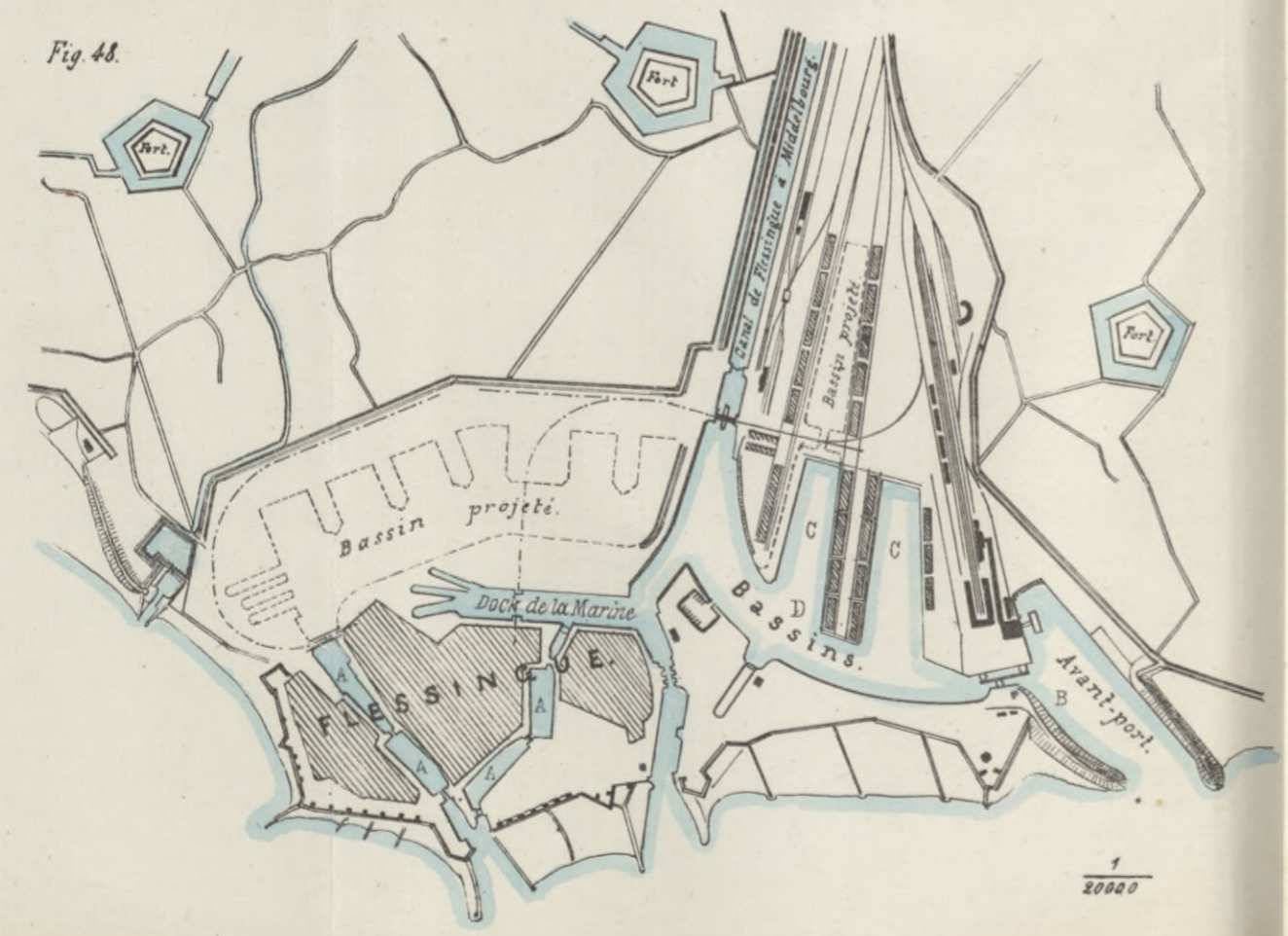

Fig. 49.

Projet de la C<sup>ie</sup> Poutiloff.

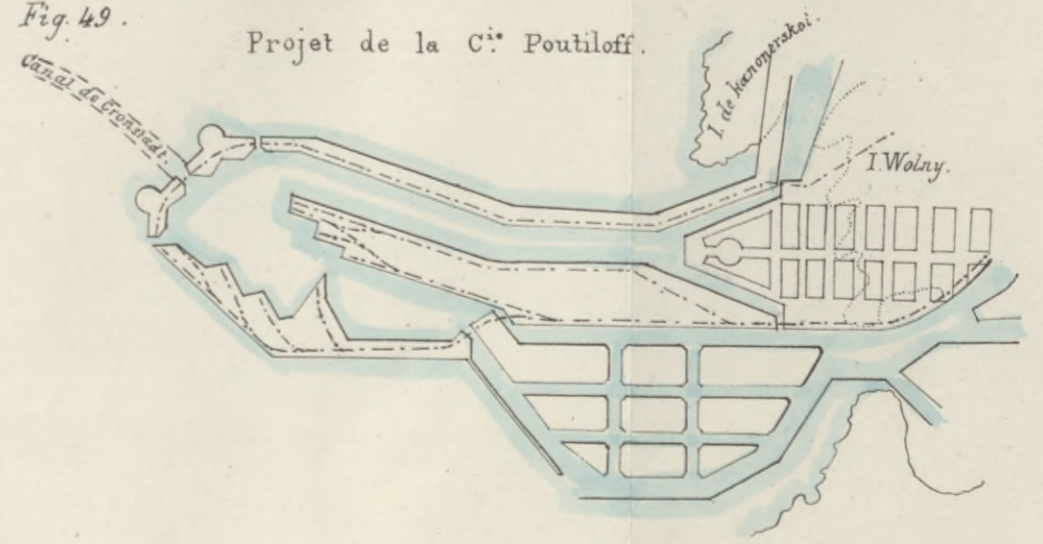
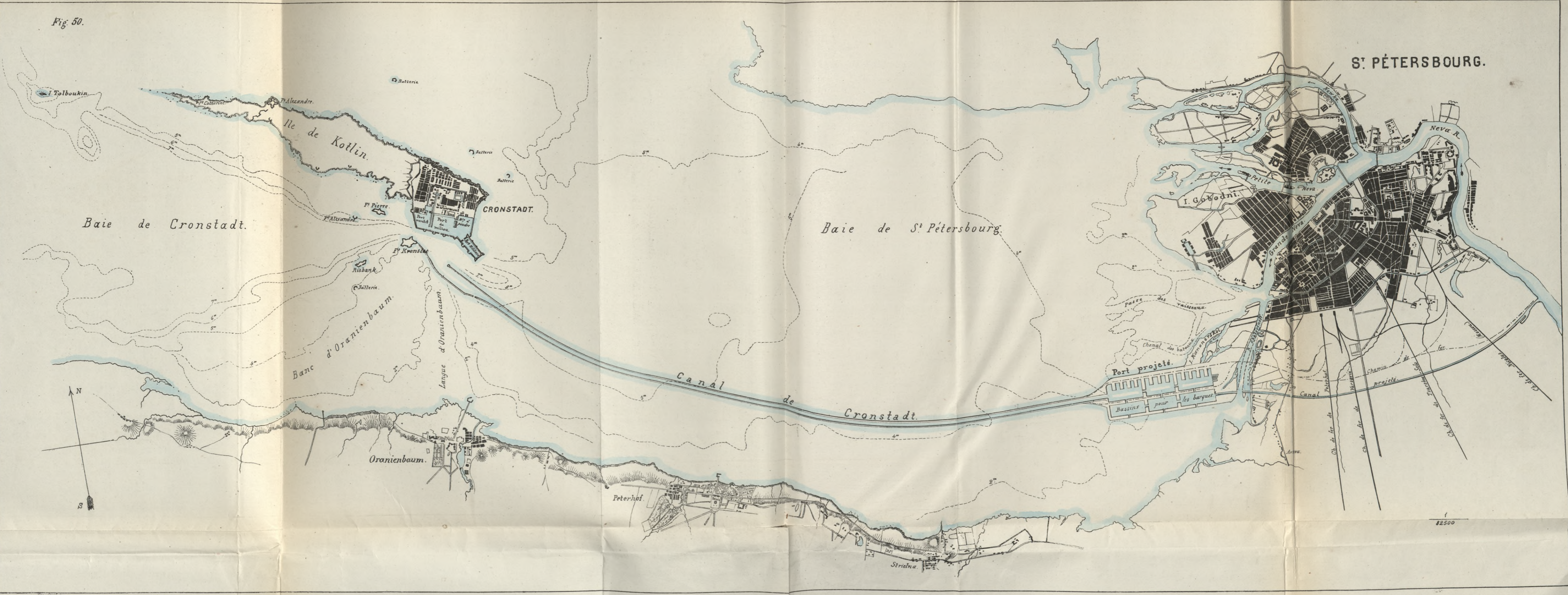





Fig. 50.



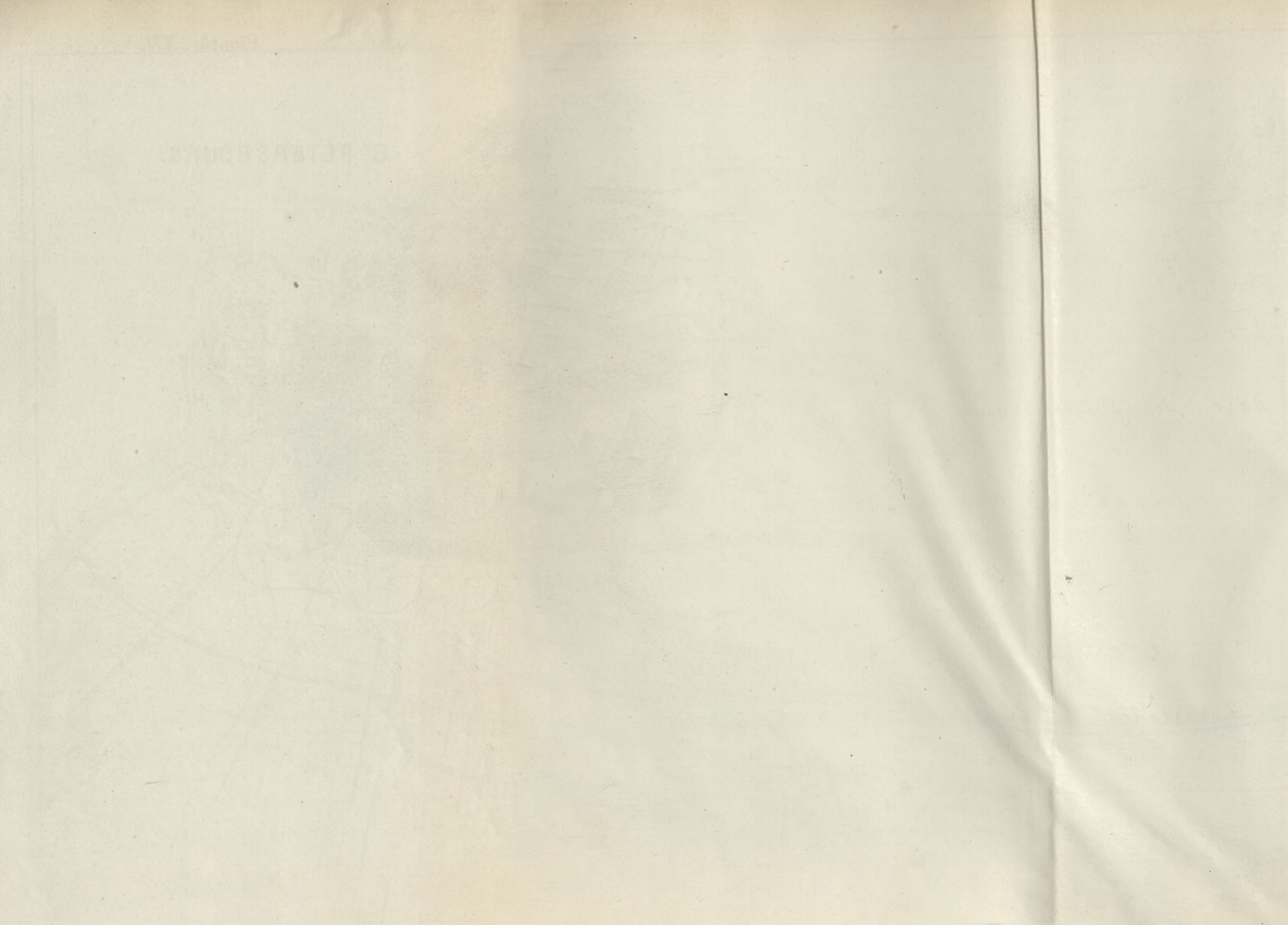
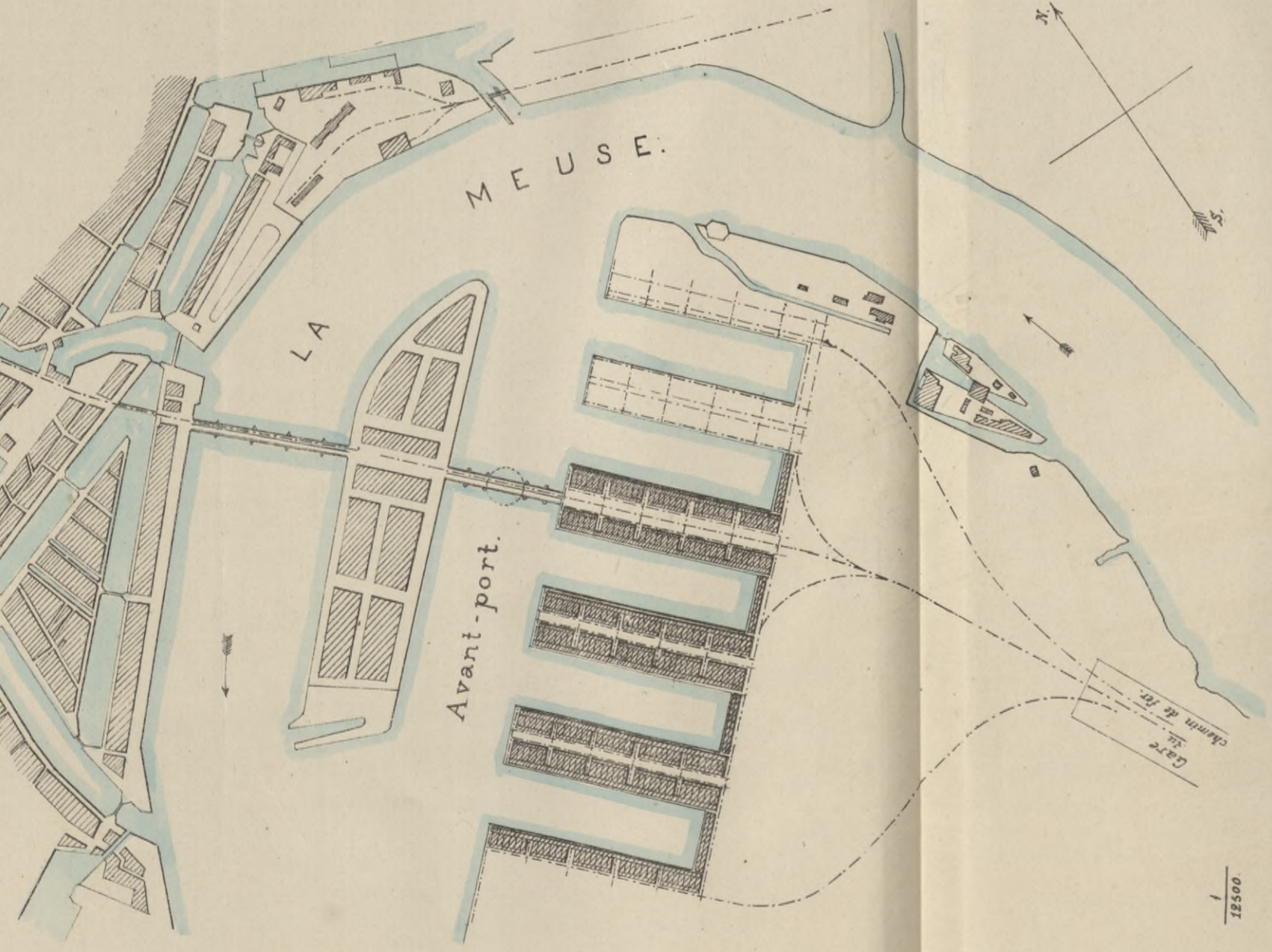





Fig. 46 bis

ROTTERDAM.



Projet de port pour St. Petersbourg.

Fig. 51.

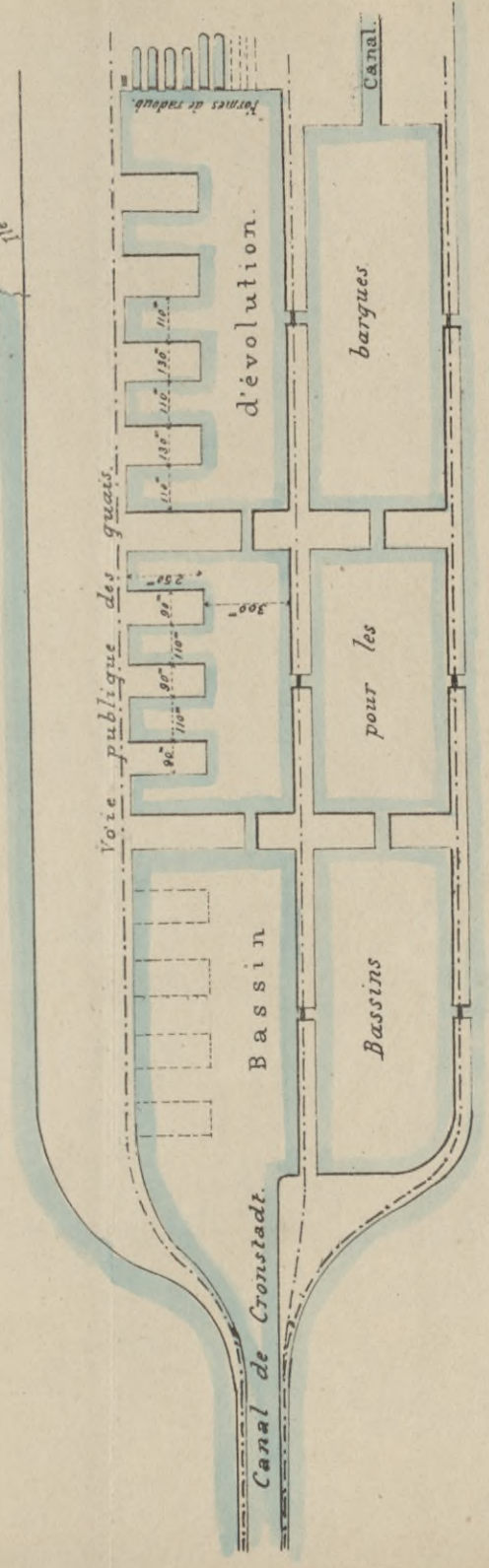







Fig. 54.

Port de PERNAMBUCO.



Fig. 55.

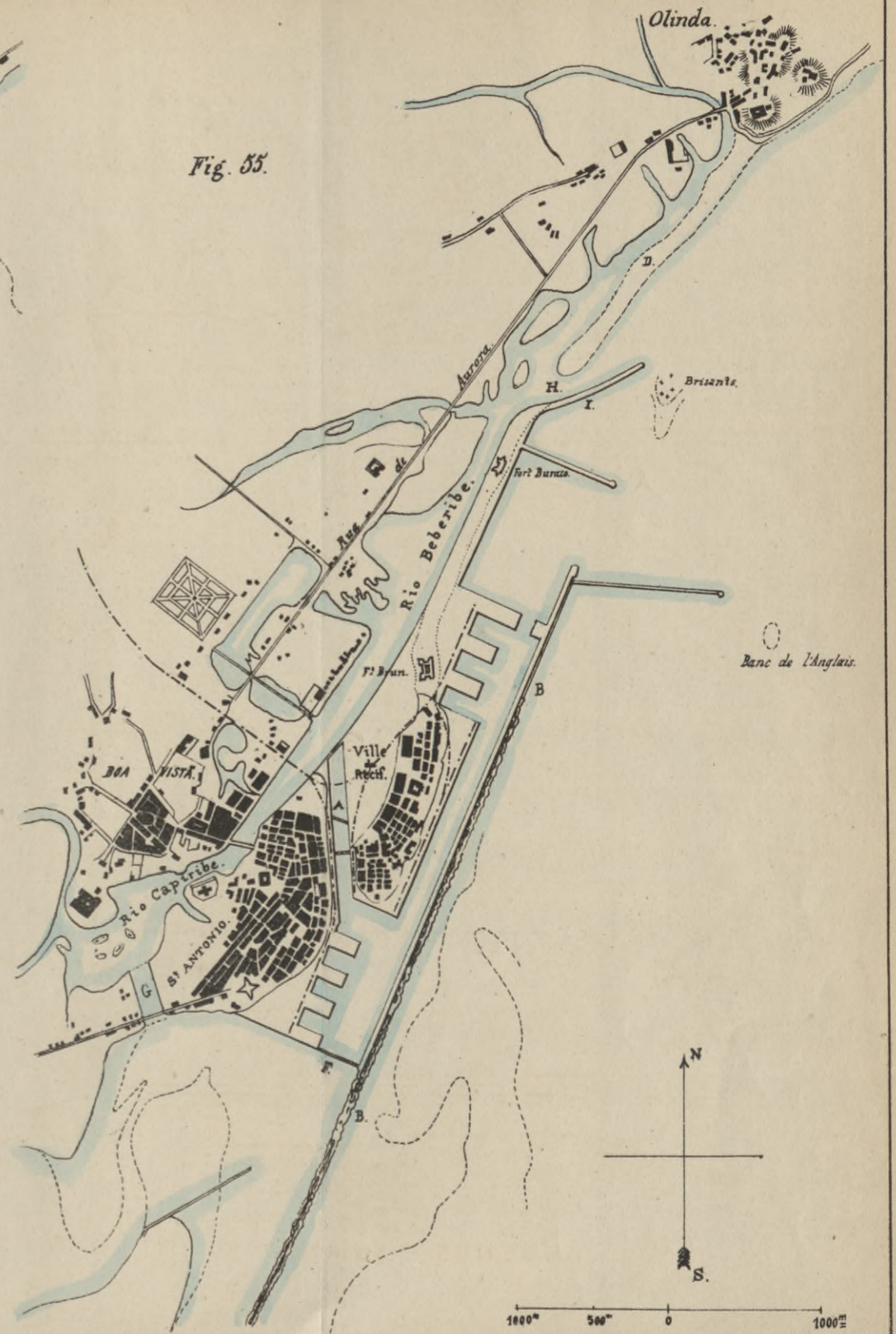

Fig. 53.

Rio - de - la - Plata

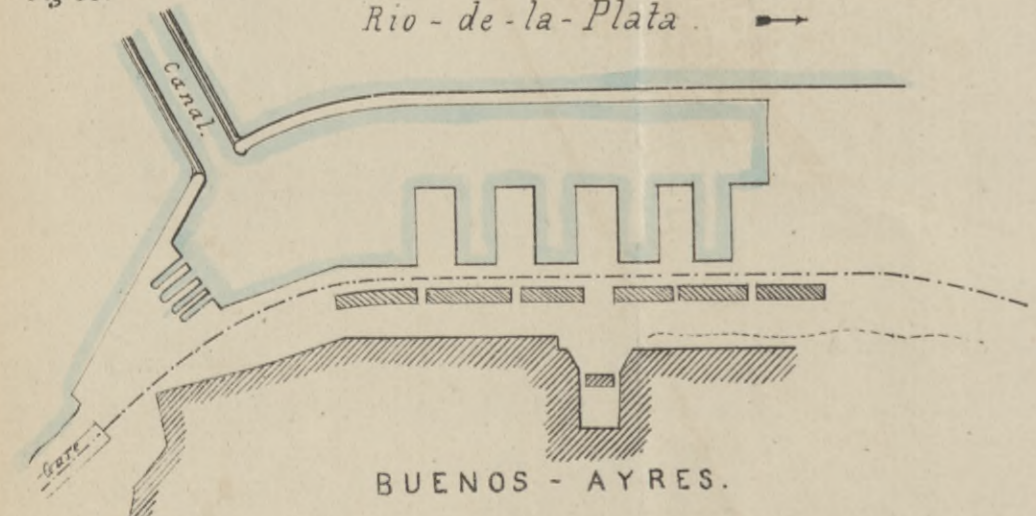





Fig. 56.



Fig. 57.

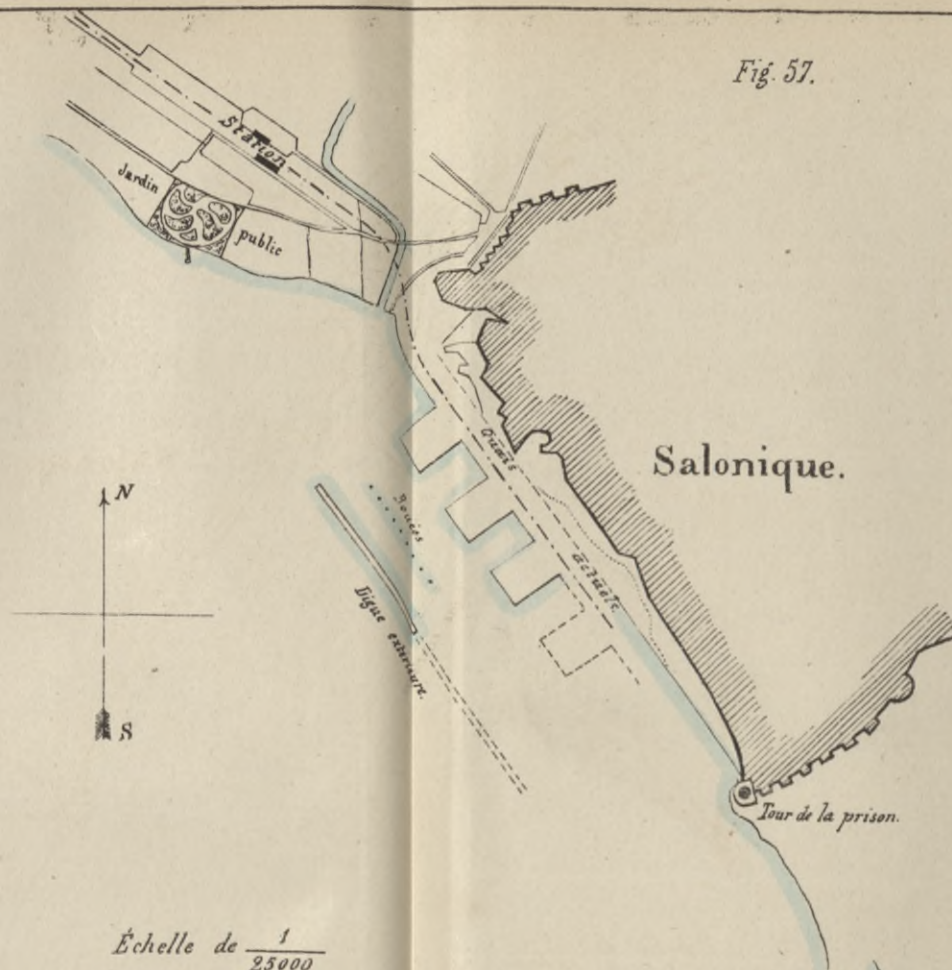
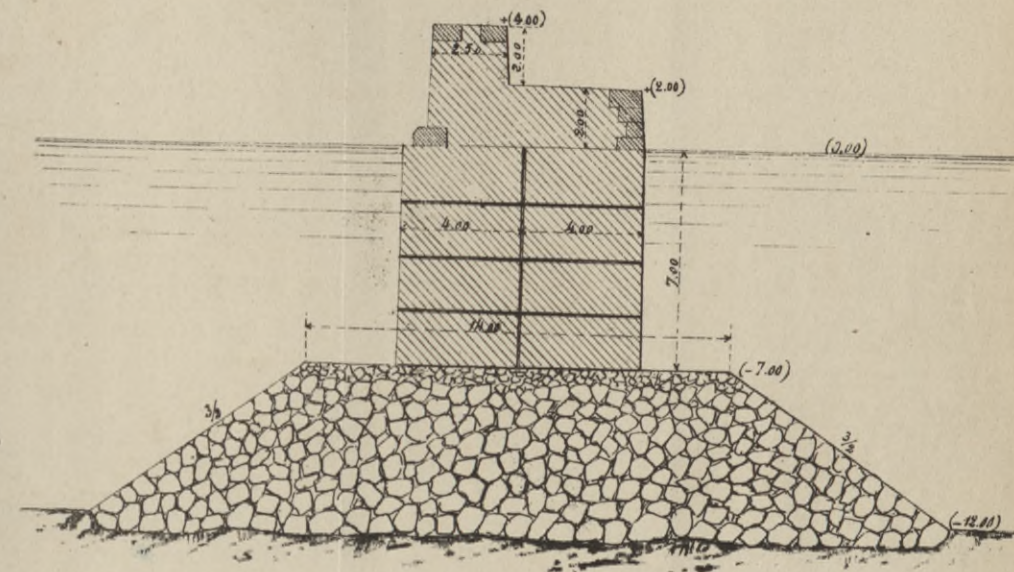

Fig. 58.



Échelle de  $\frac{1}{25000}$

Fig. 59.

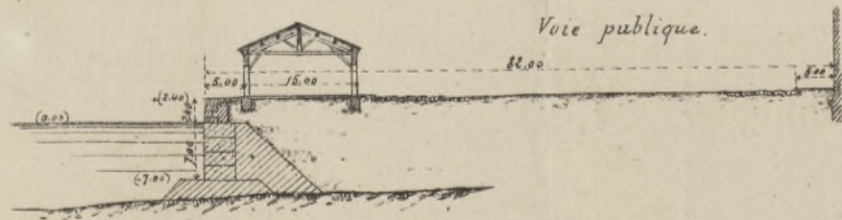

Fig. 60.

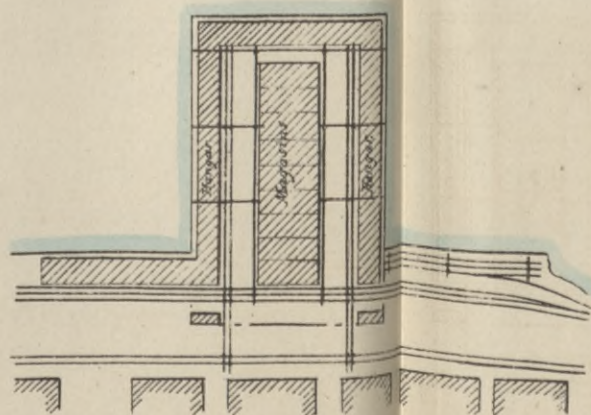

Fig. 61.

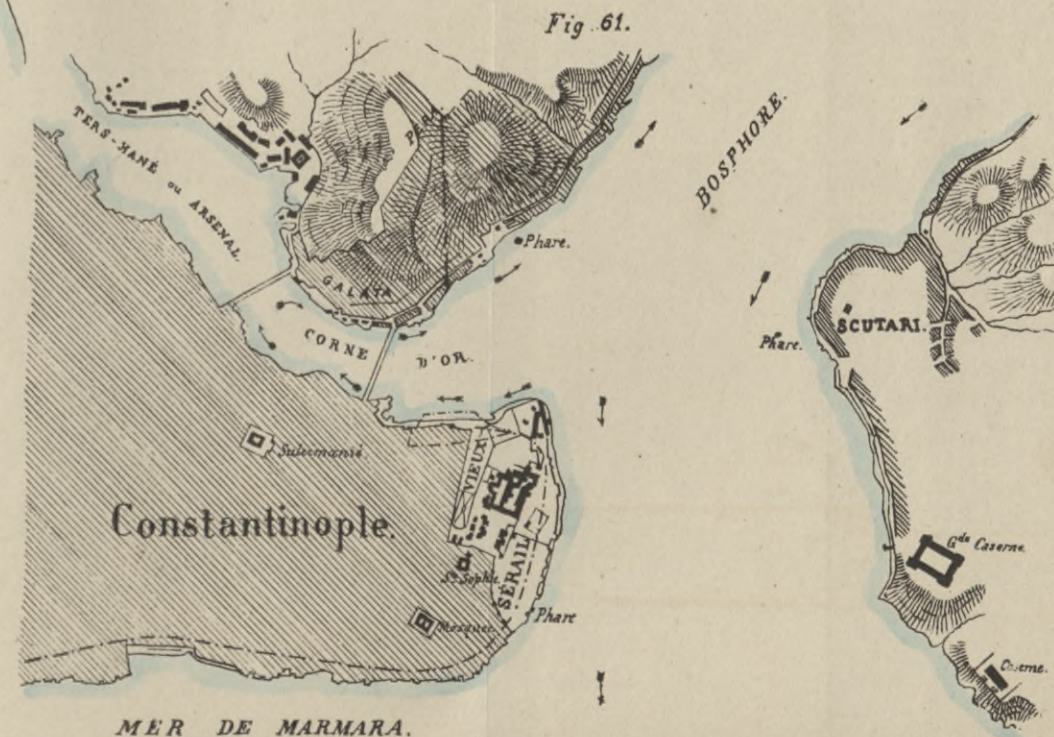







Fig. 62.

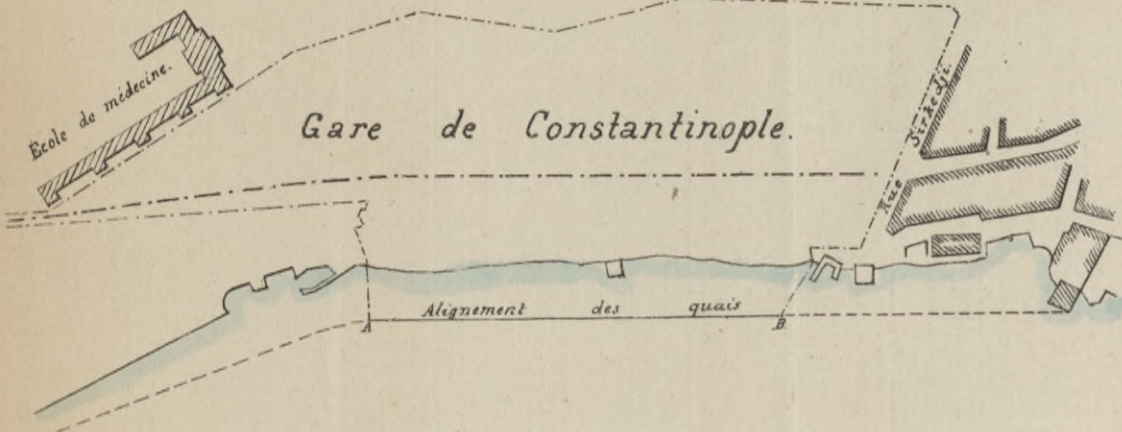

Fig. 64.

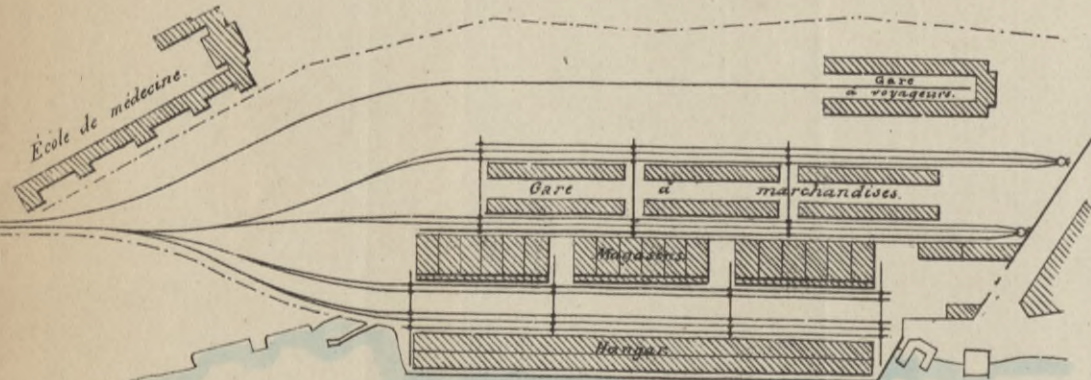

Fig. 65.

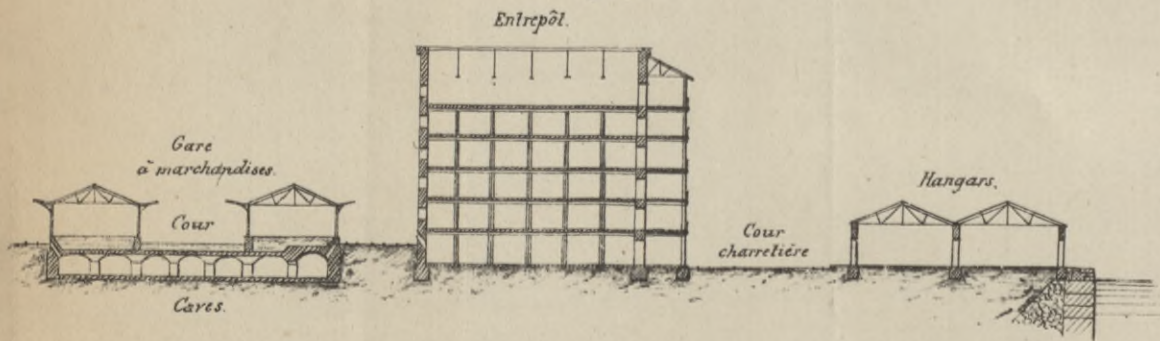

Fig. 66.

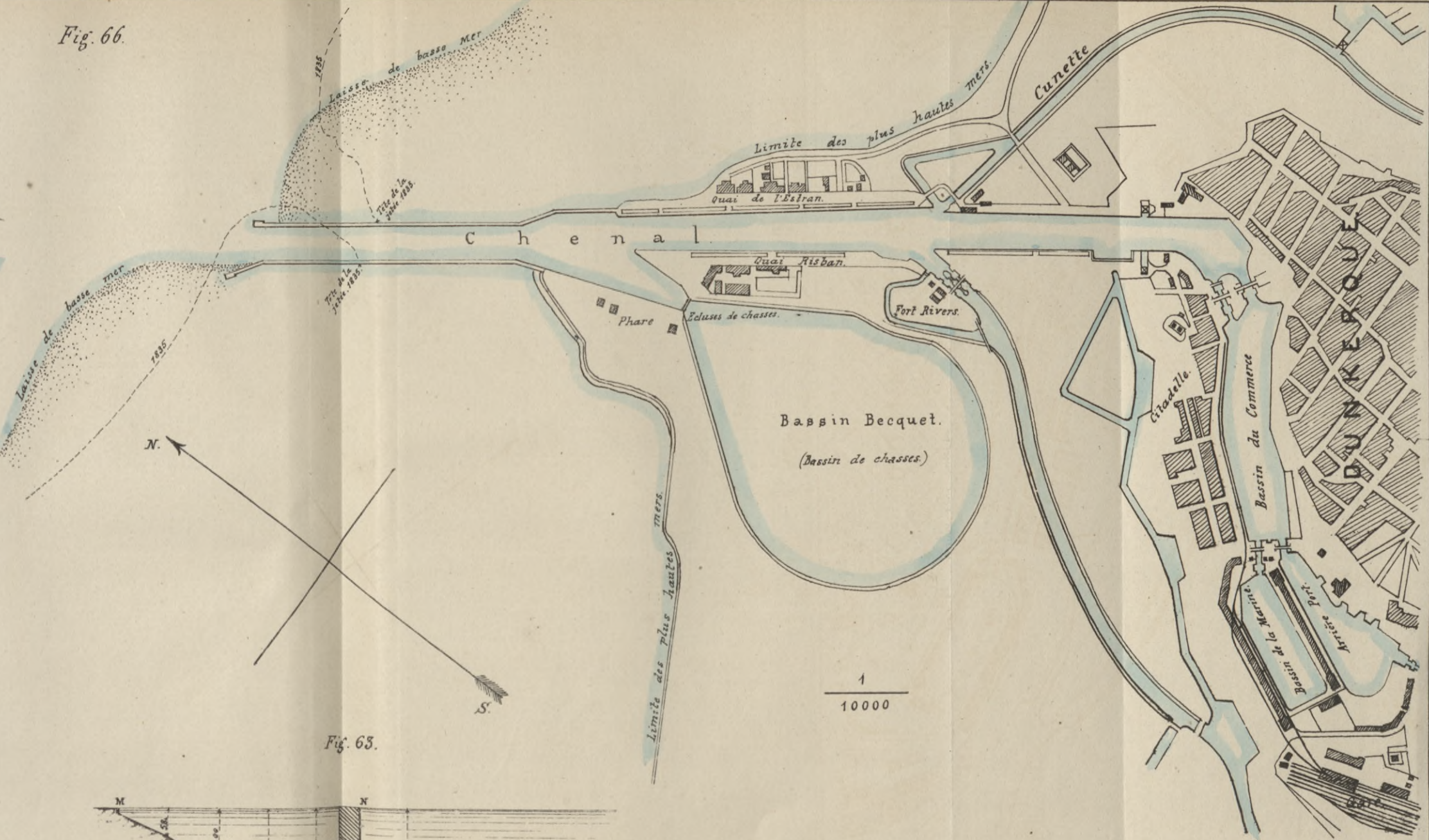
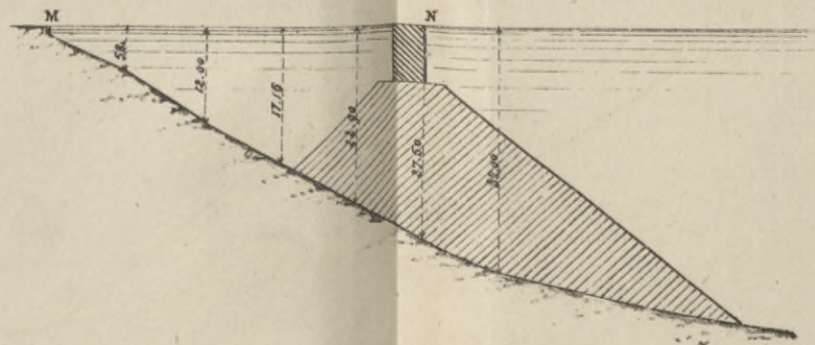
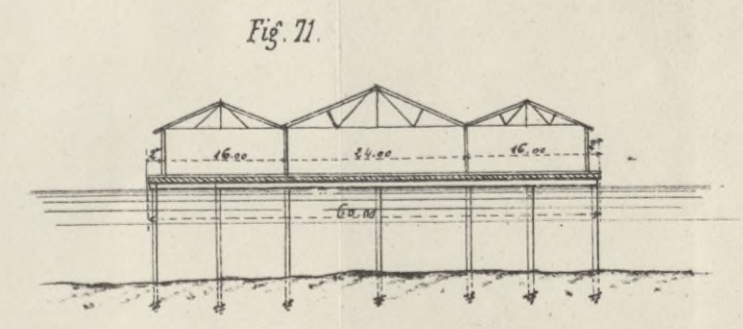
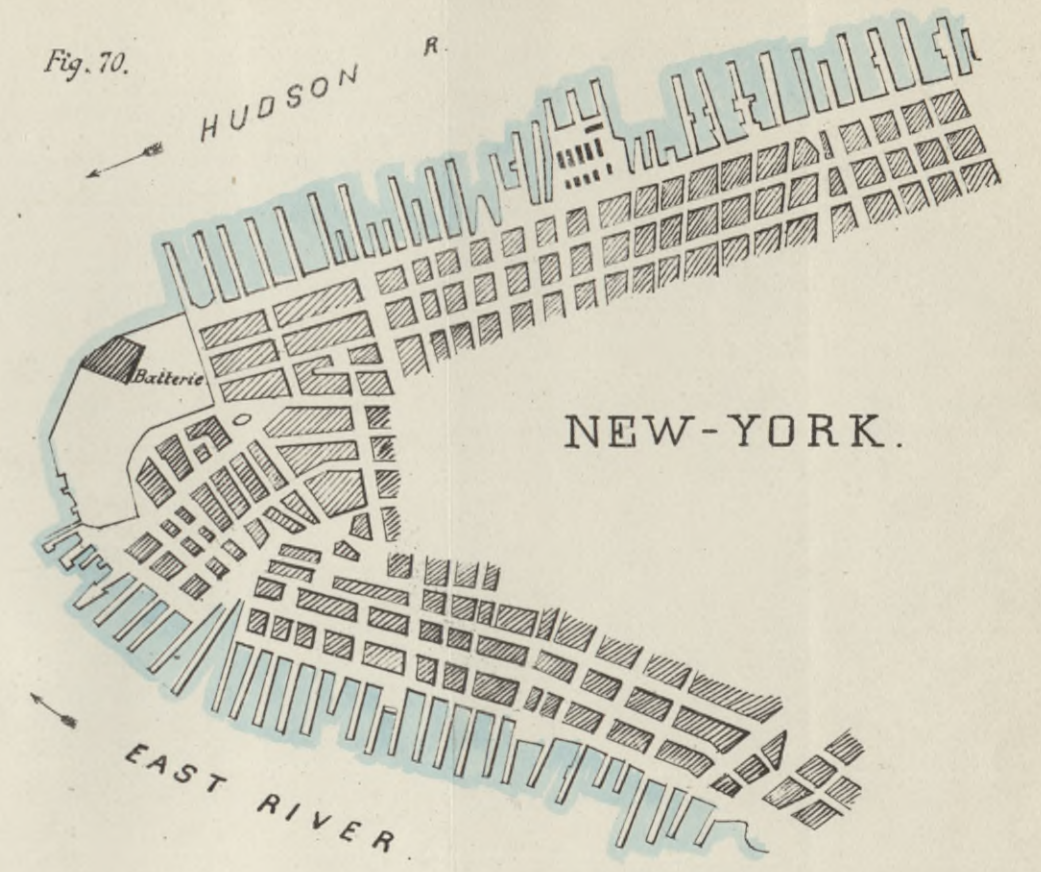
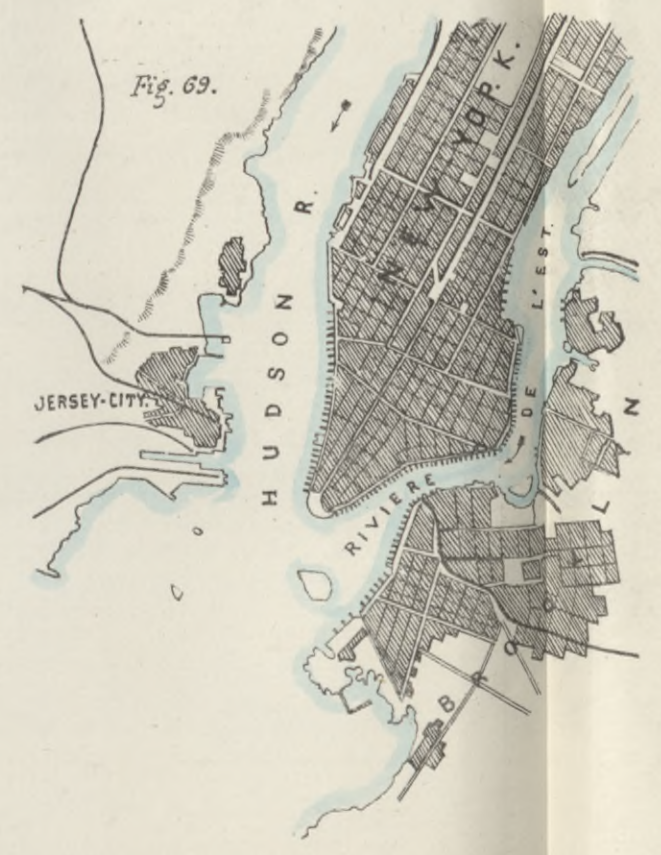
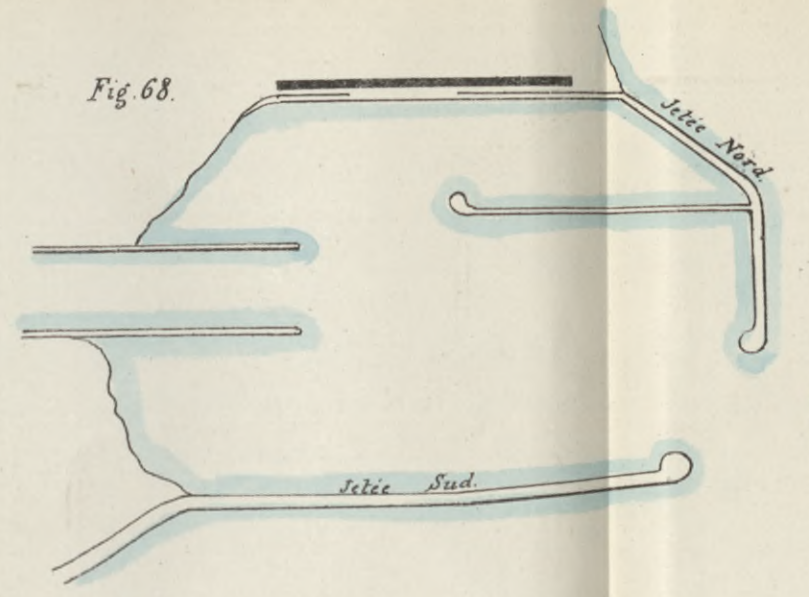
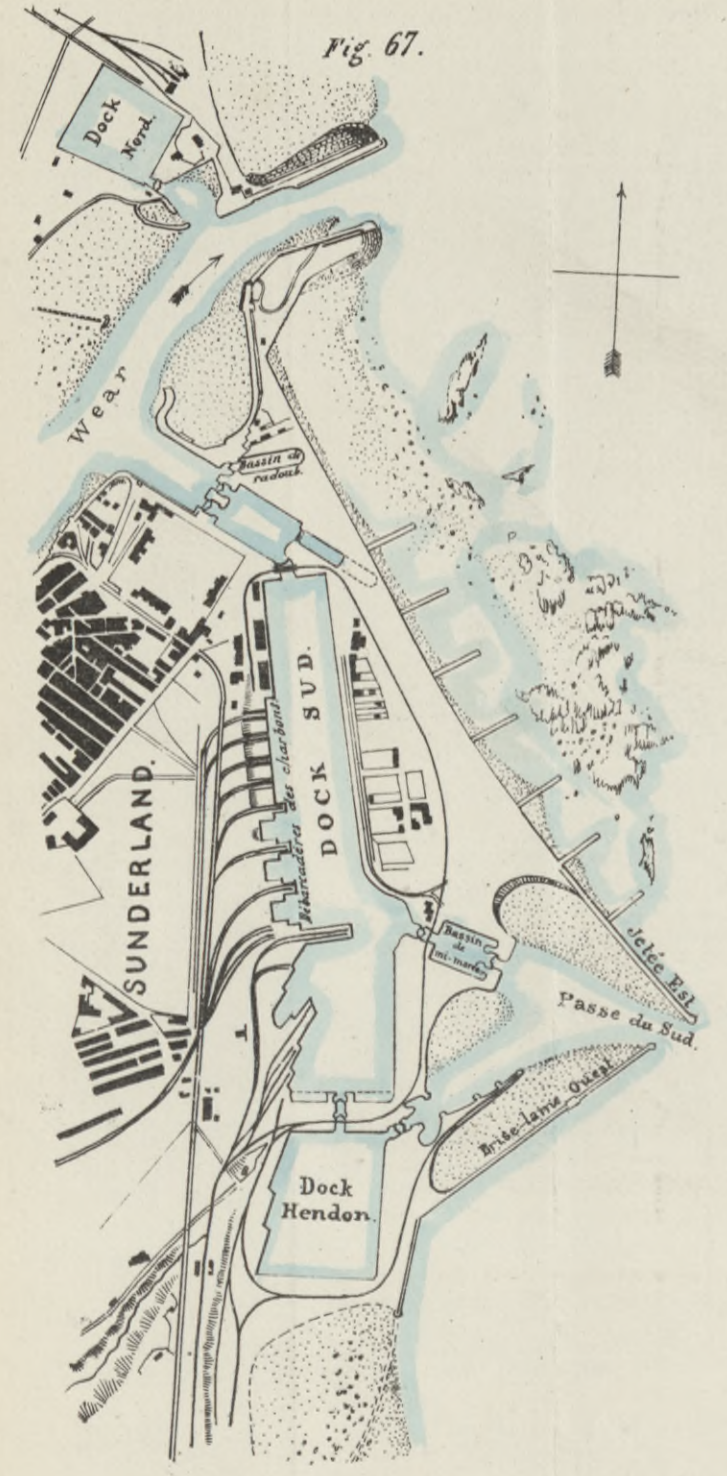

Fig. 63.















# Plan des docks de Liverpool.

Fig. 72.

( $\frac{1}{9600}$ )

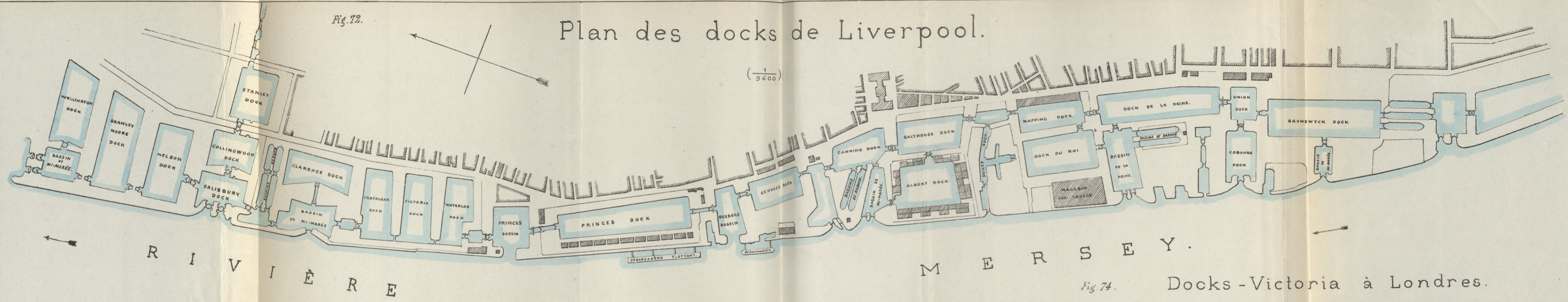

Fig. 73.

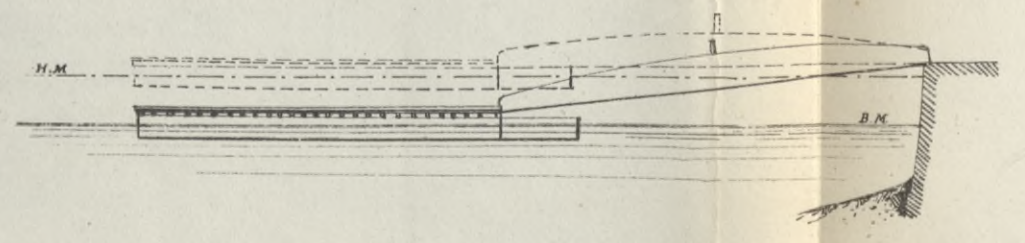

Fig. 75. Coupe transversale d'un môle des Docks Victoria.

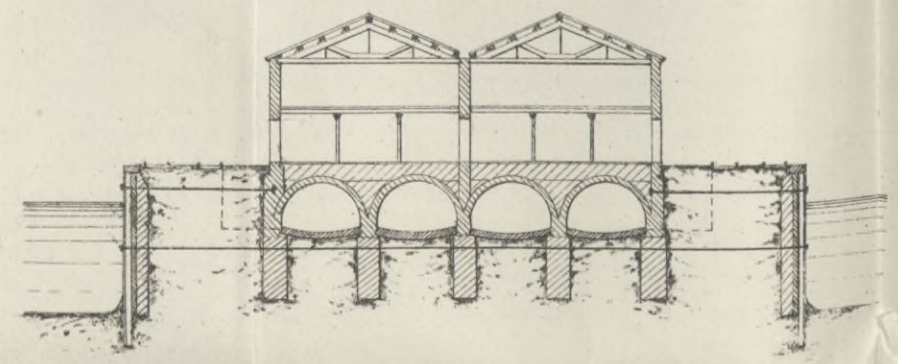
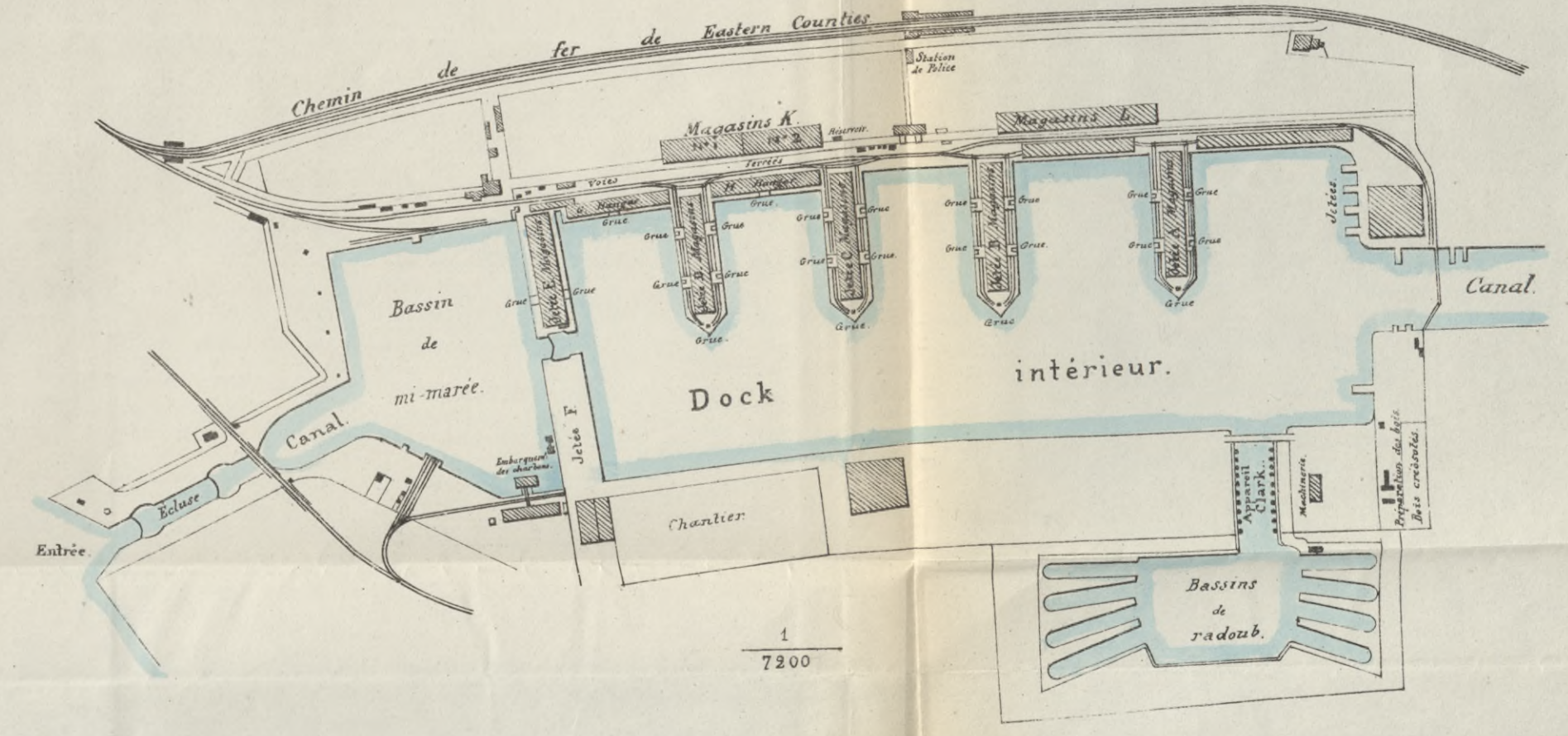

Fig. 74.

# Docks - Victoria à Londres.



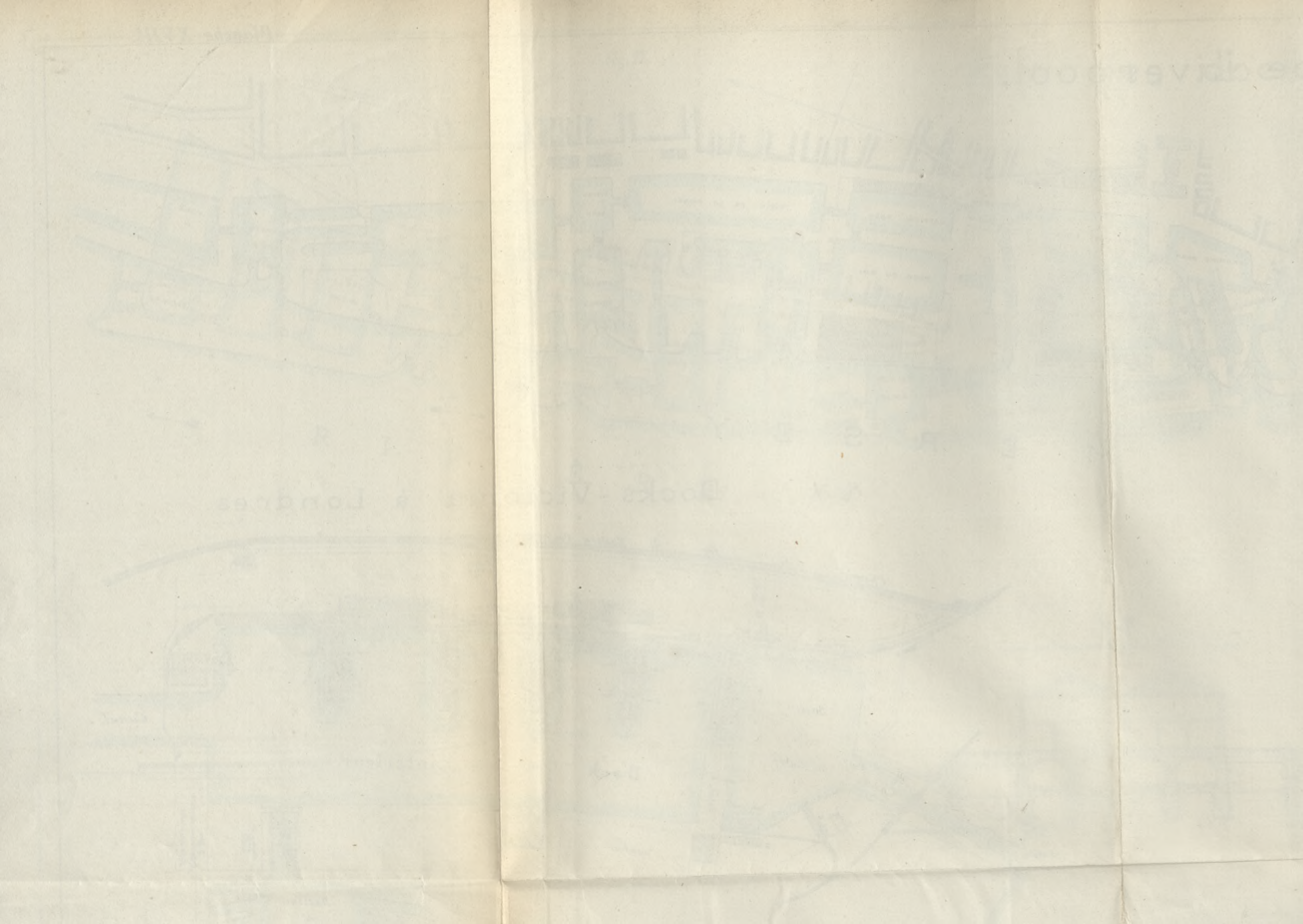



Fig. 76.  
Docks de South-Shields.

$\frac{1}{5000}$

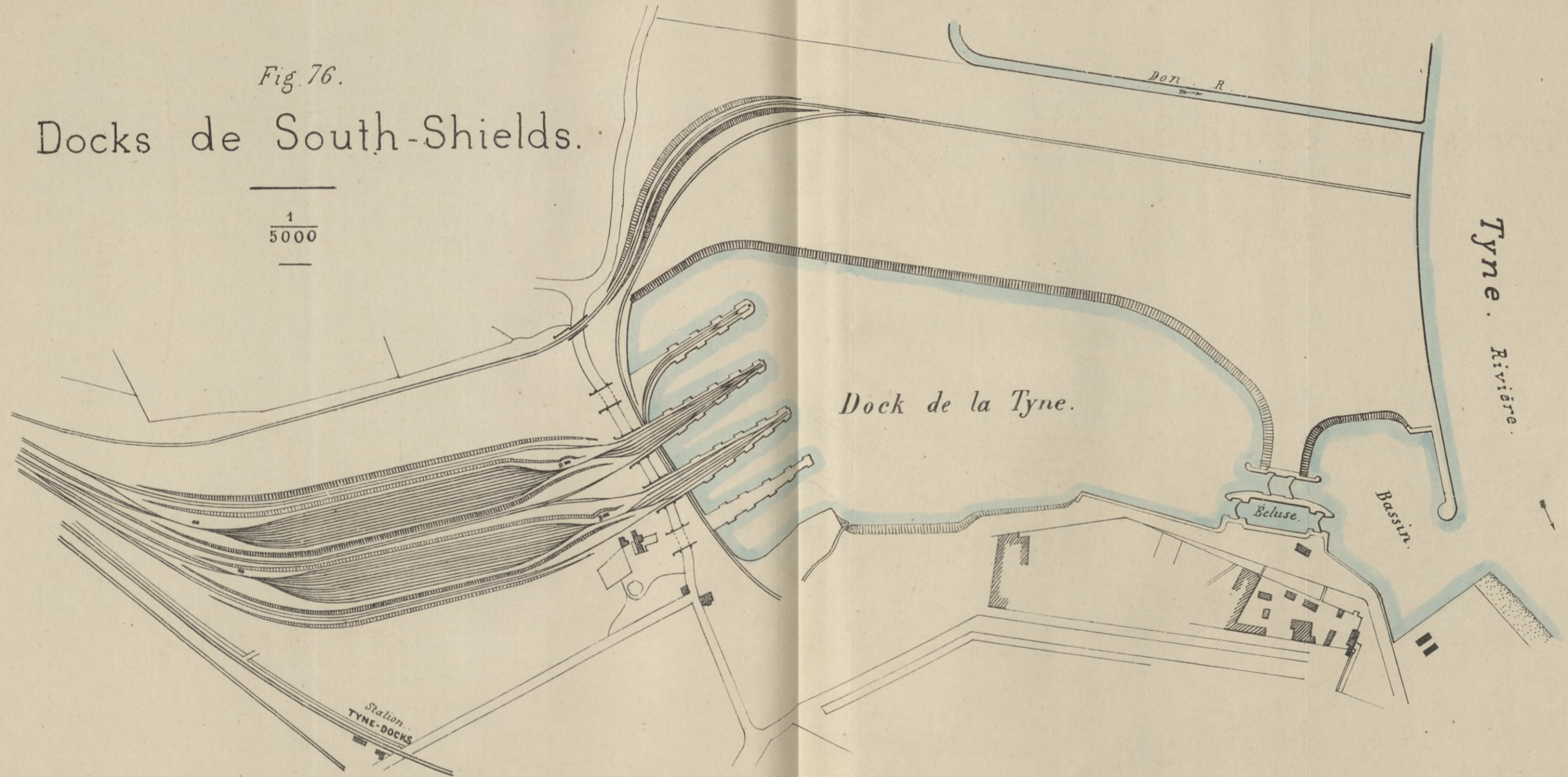





Fig. 17.

Jetées de South-Shields.

Coupe transversale.

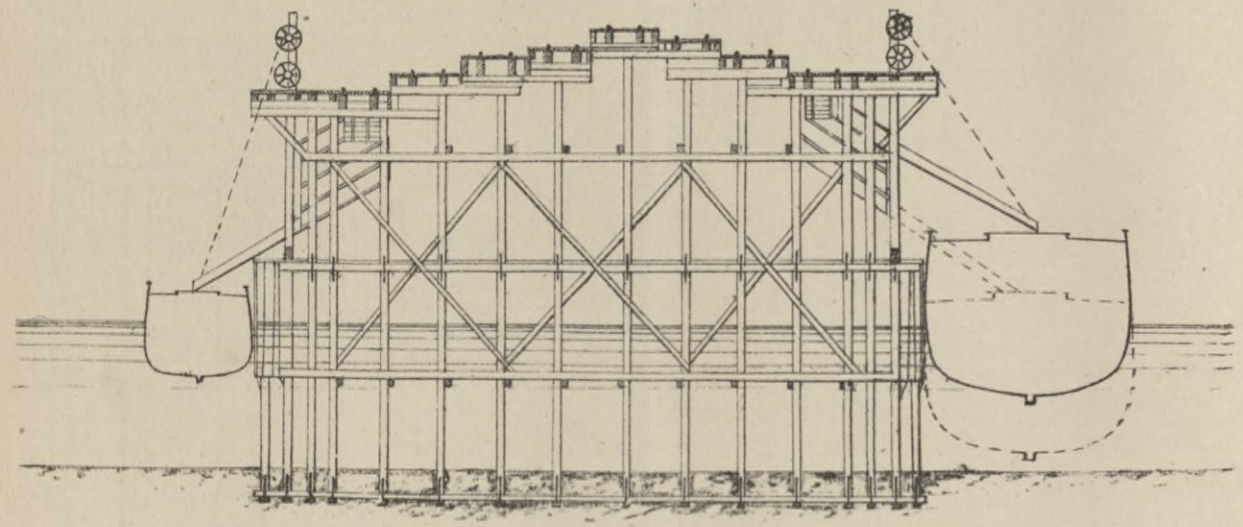

Fig. 78.

Couloirs de South-Shields.

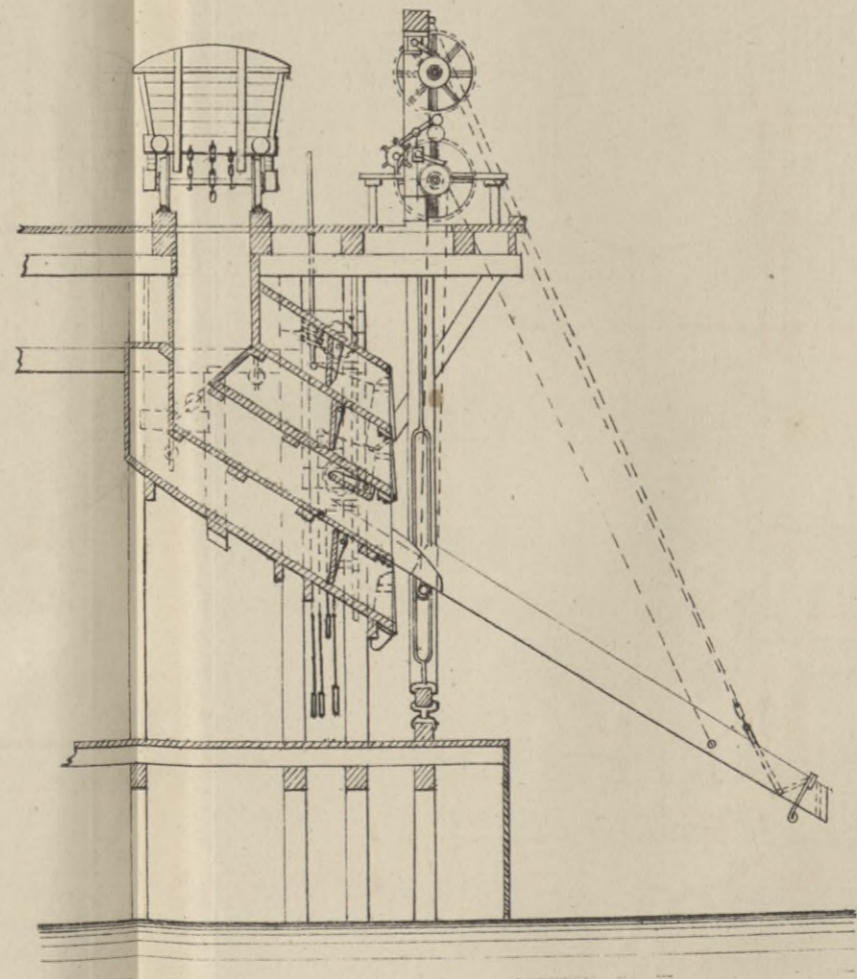

Fig. 80.

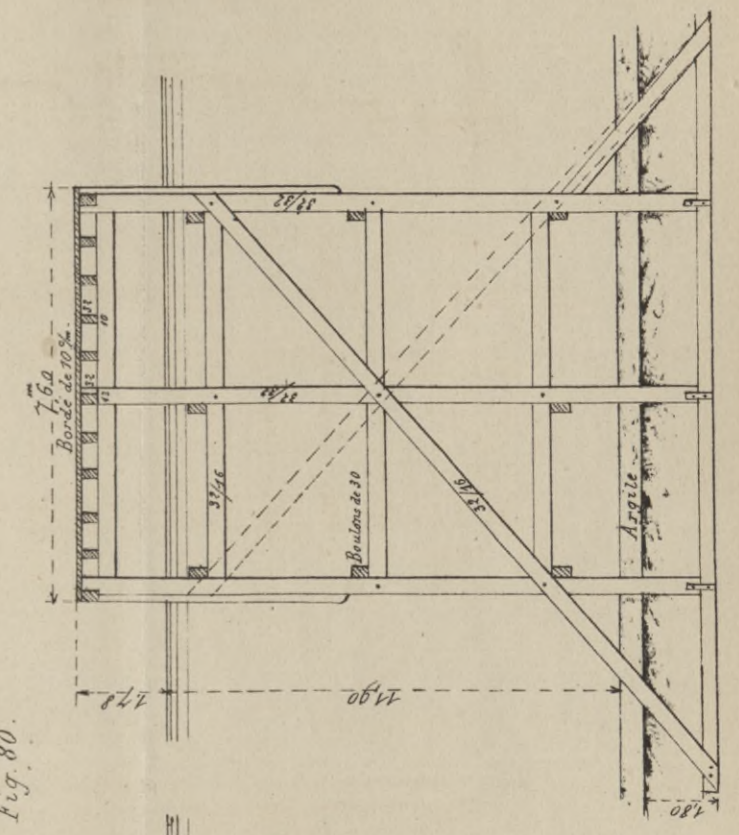
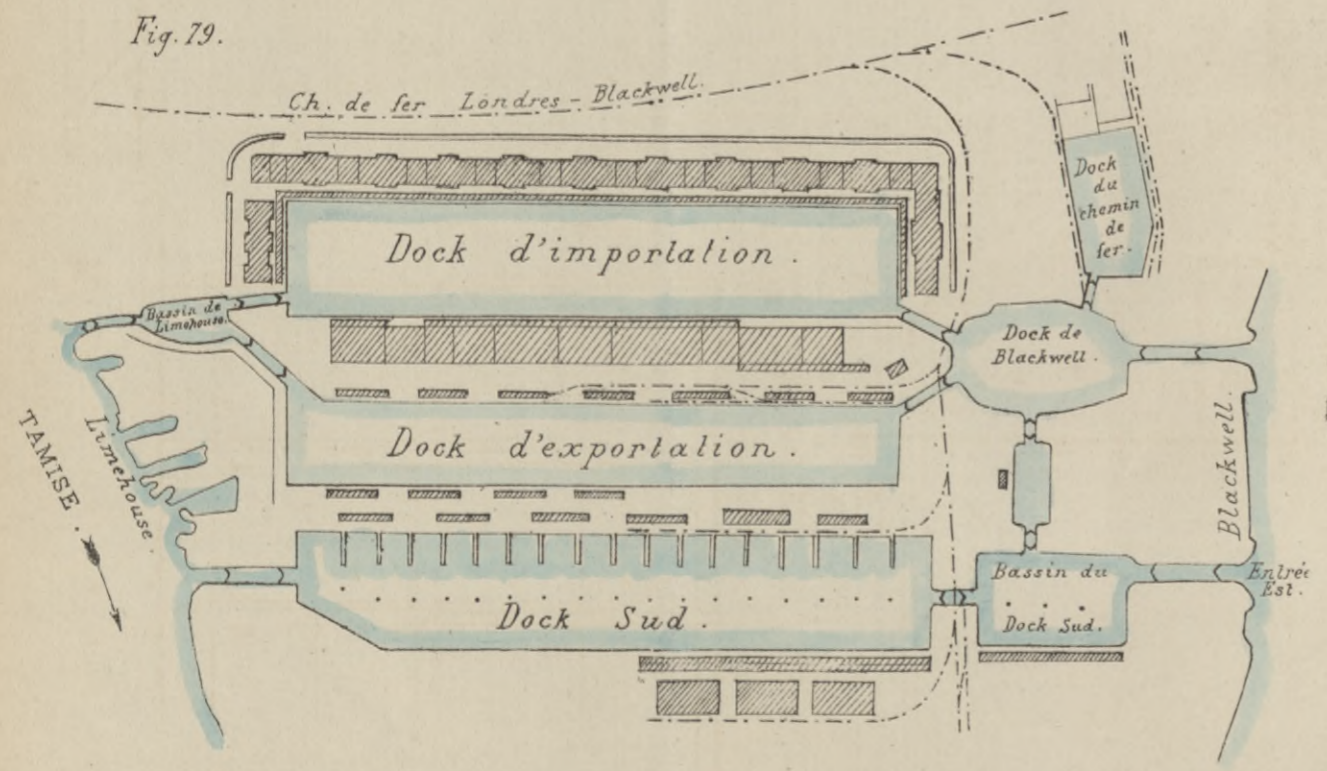
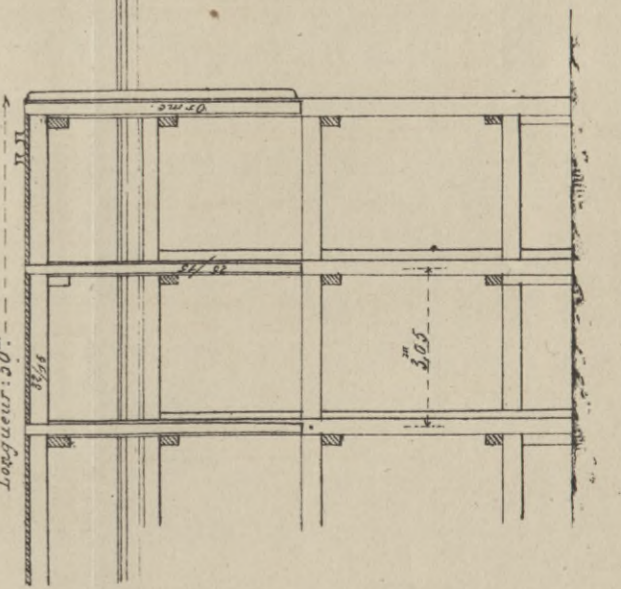

Fig. 79.

Ch. de fer Londres - Blackwell.



Longueur: 50 m.



Docks des Indes occidentales.  
Jetées du Dock Sud.

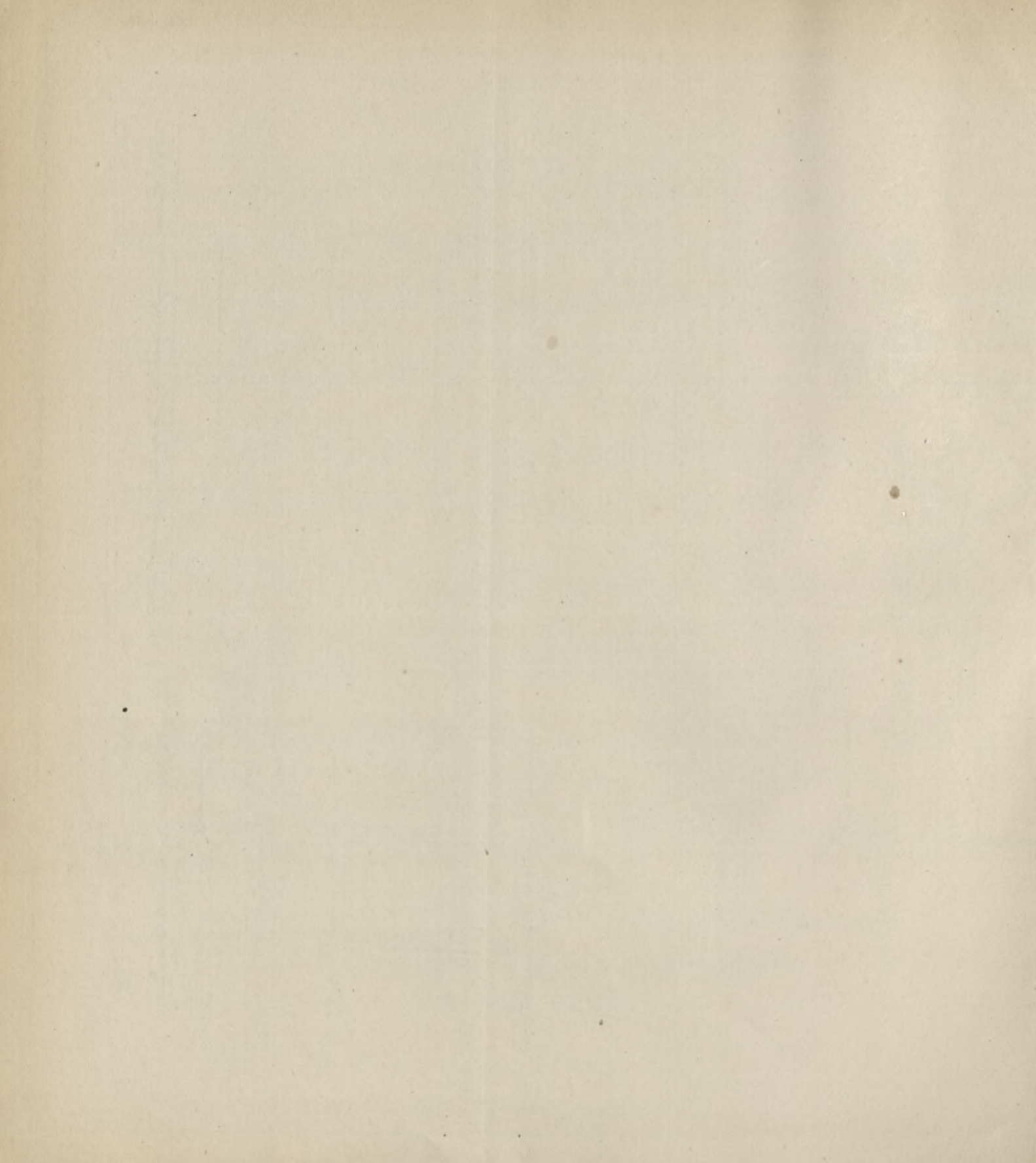





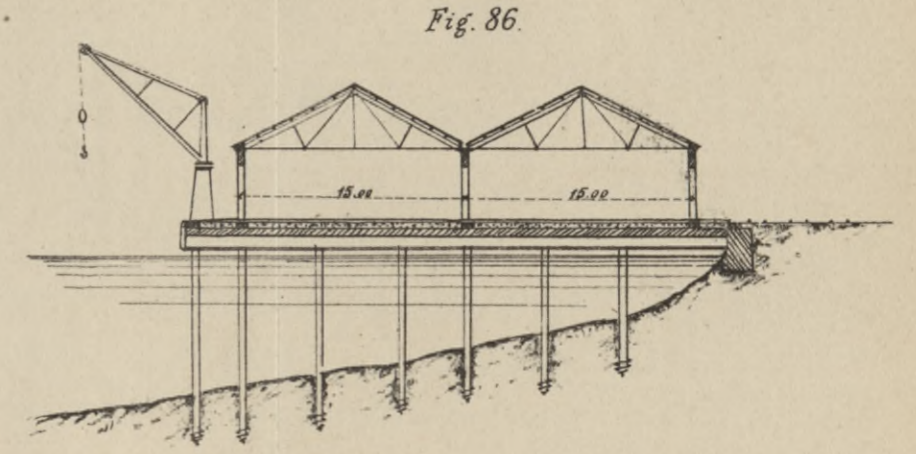
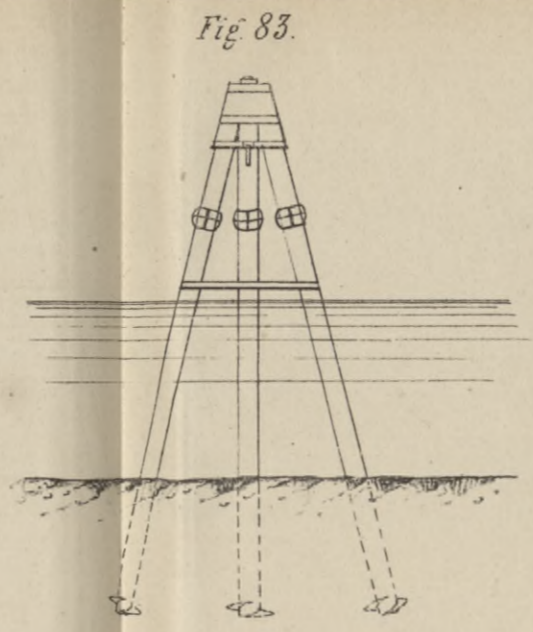

Fig. 84. Plan d'ensemble du Sandthorhafen, à Hambourg.



Fig. 87.

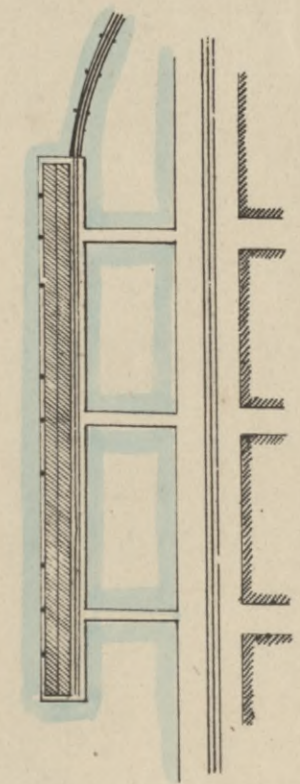

Fig. 85. Quai de rive du Sandthorhafen, à Hambourg.

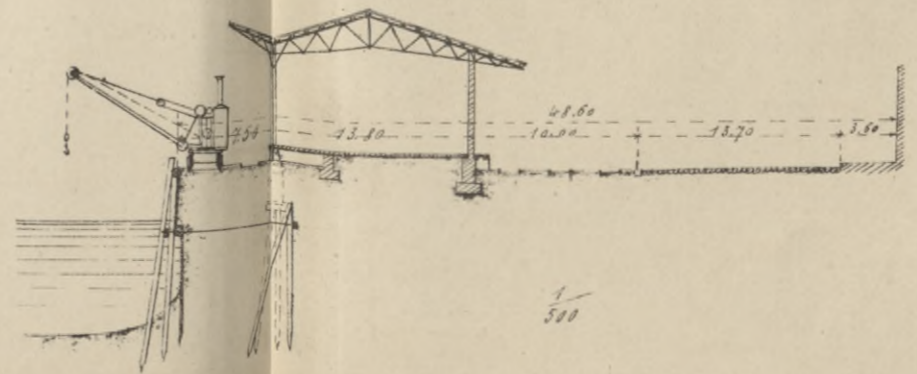





Fig. 88.

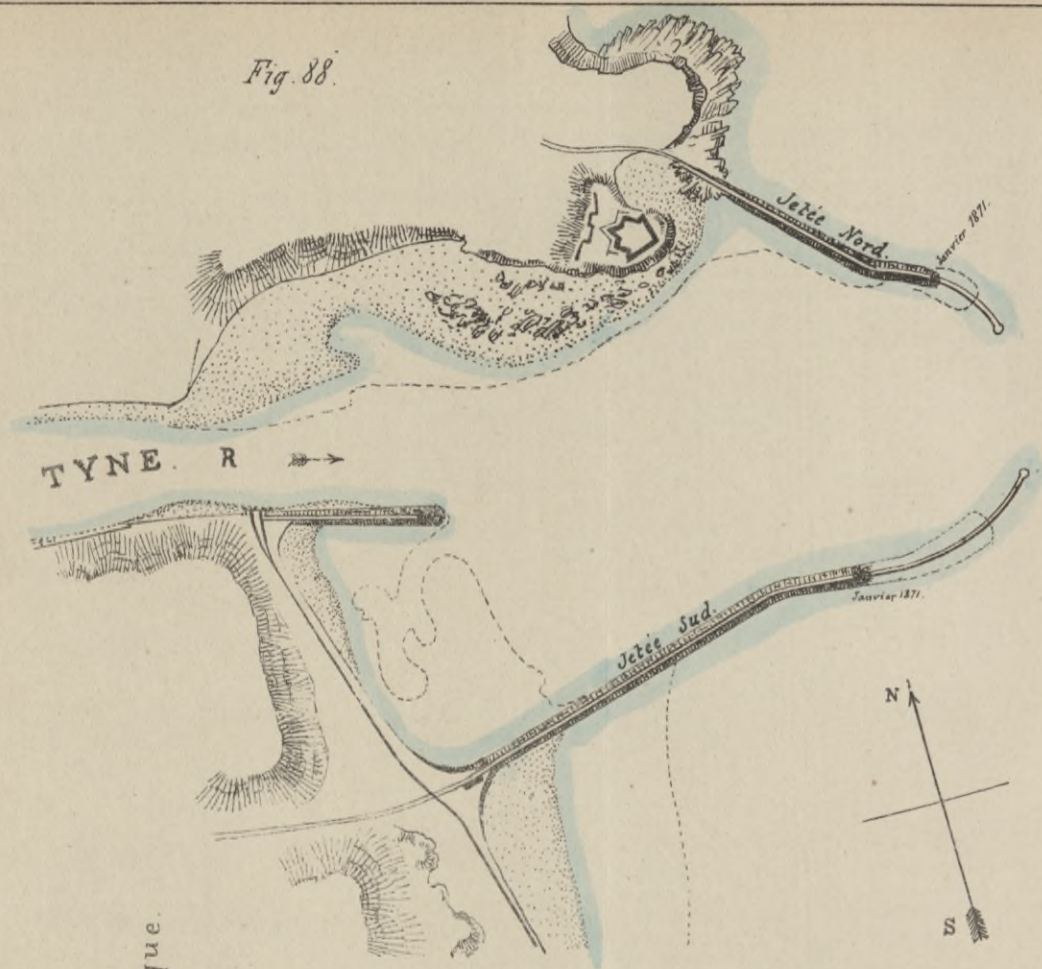

Fig. 89.

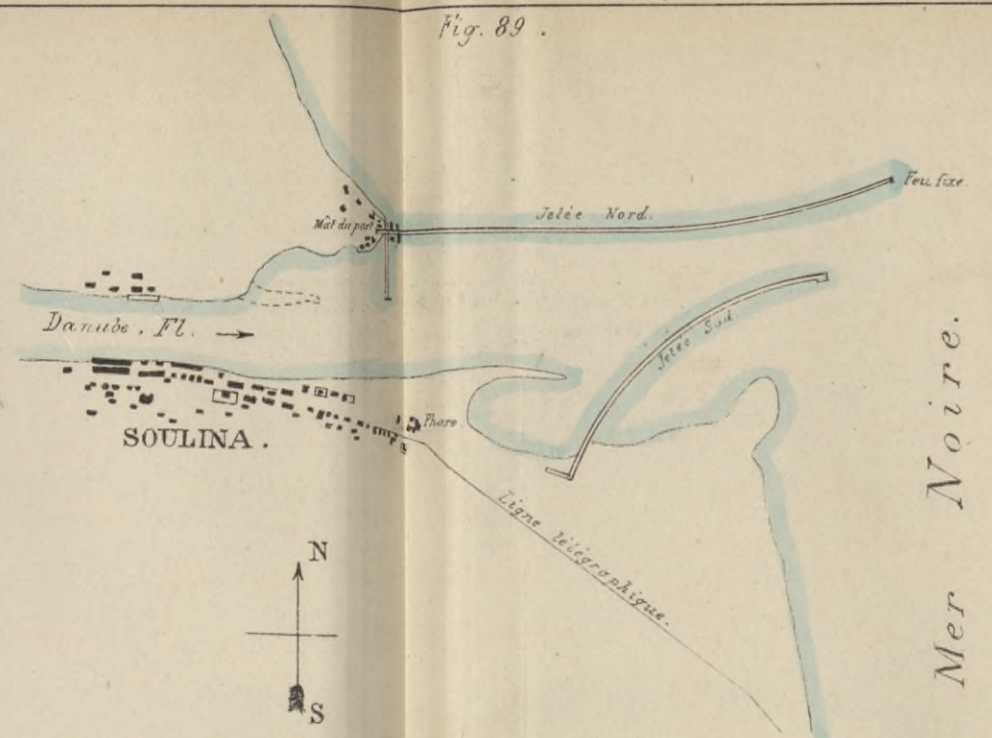

Fig. 90.

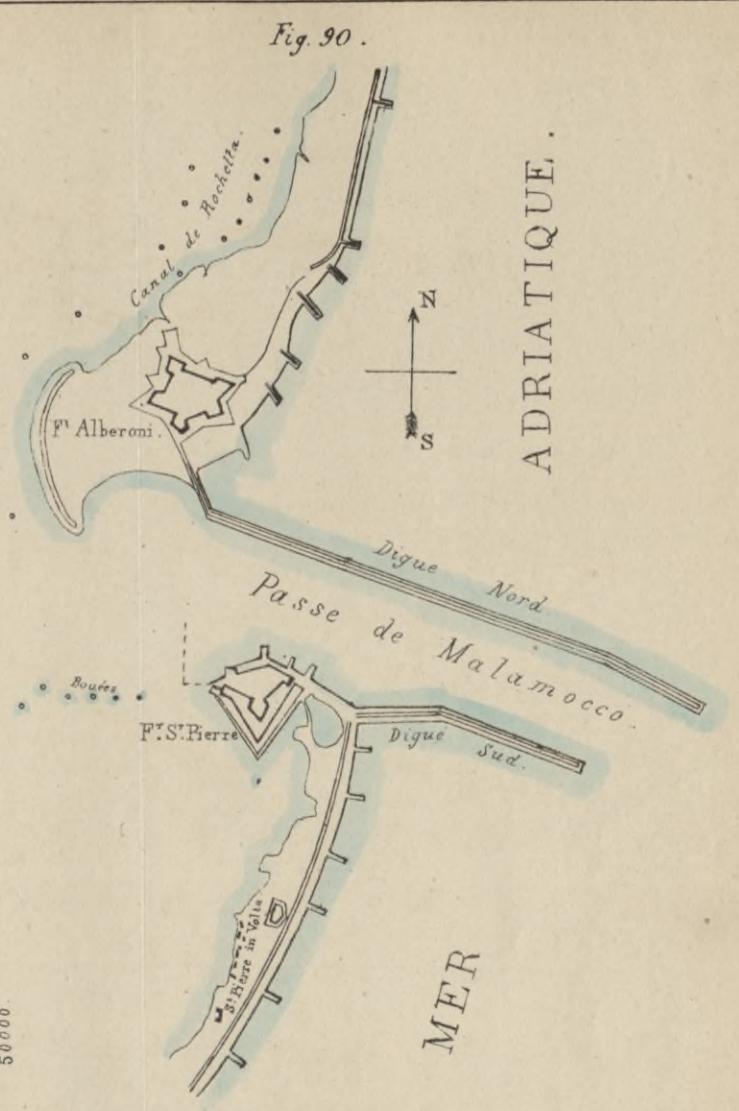

Fig. 91.

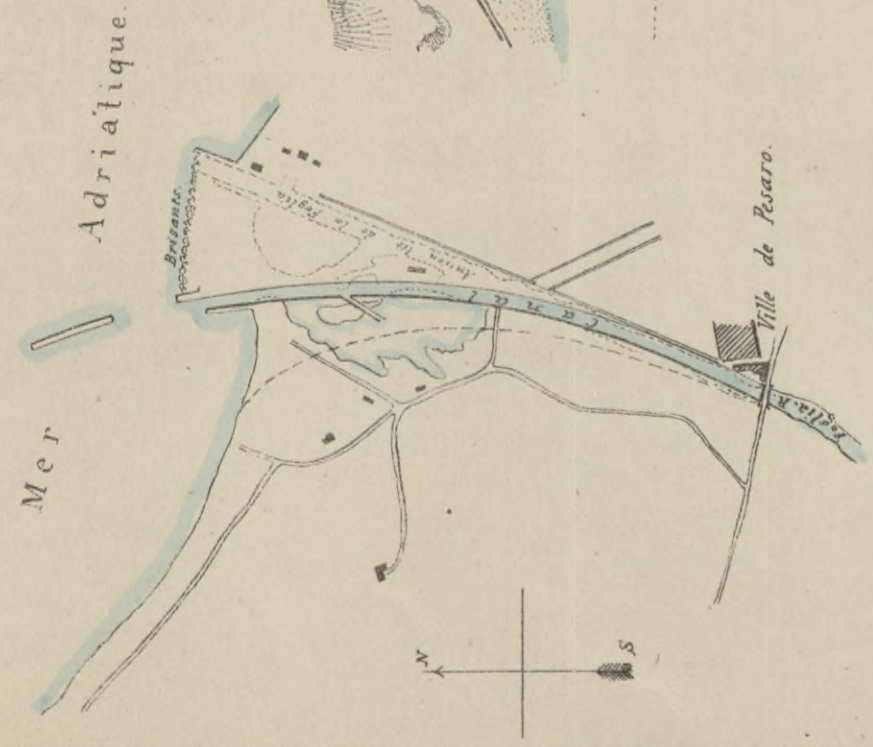

Fig. 92. Canal S. Louis.



1 / 50000





Fig. 94. Disposition générale d'une usine à fonte et à fer.

Échelle de 0.0005 par mètre.

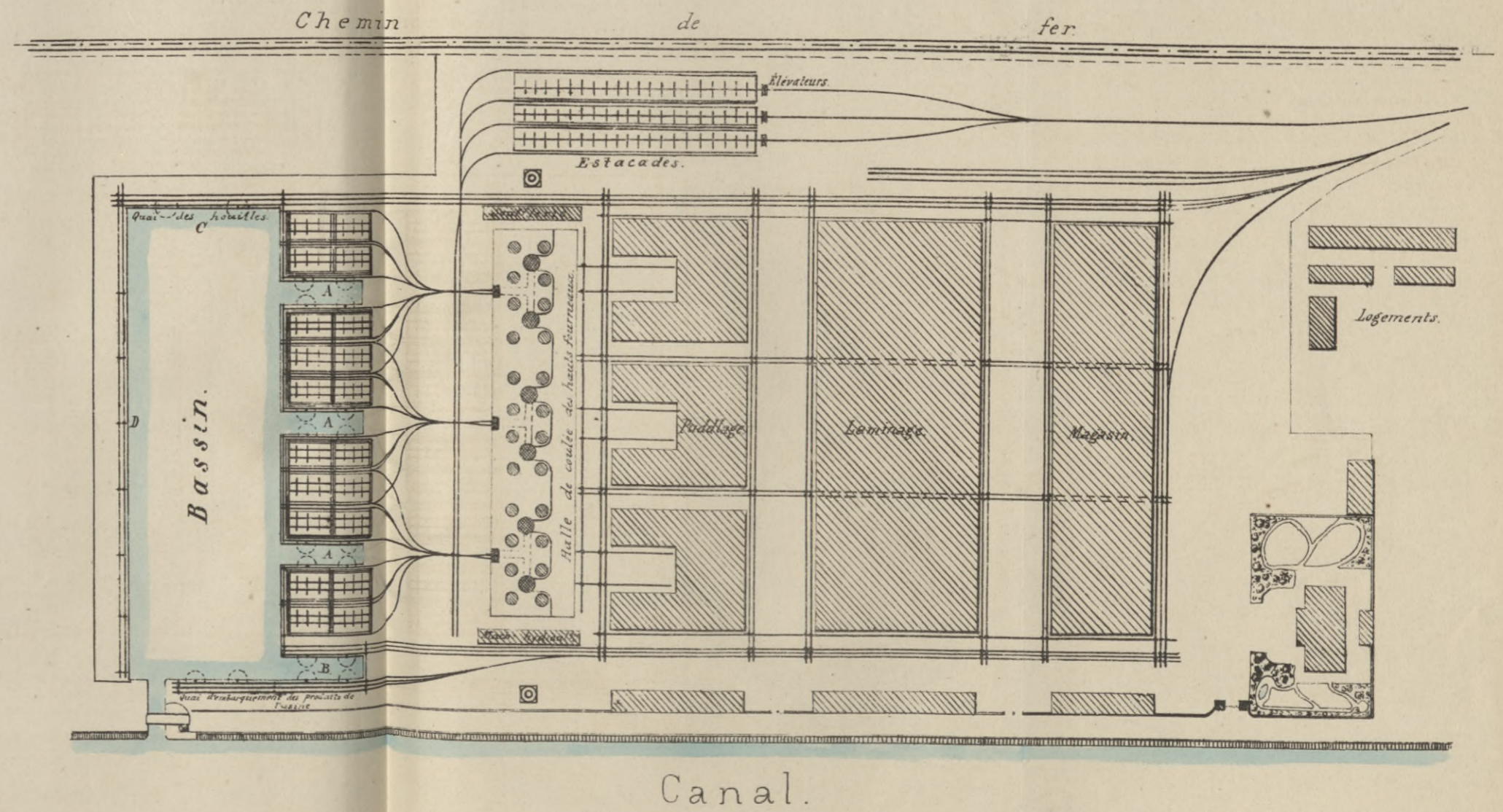

Fig. 93.

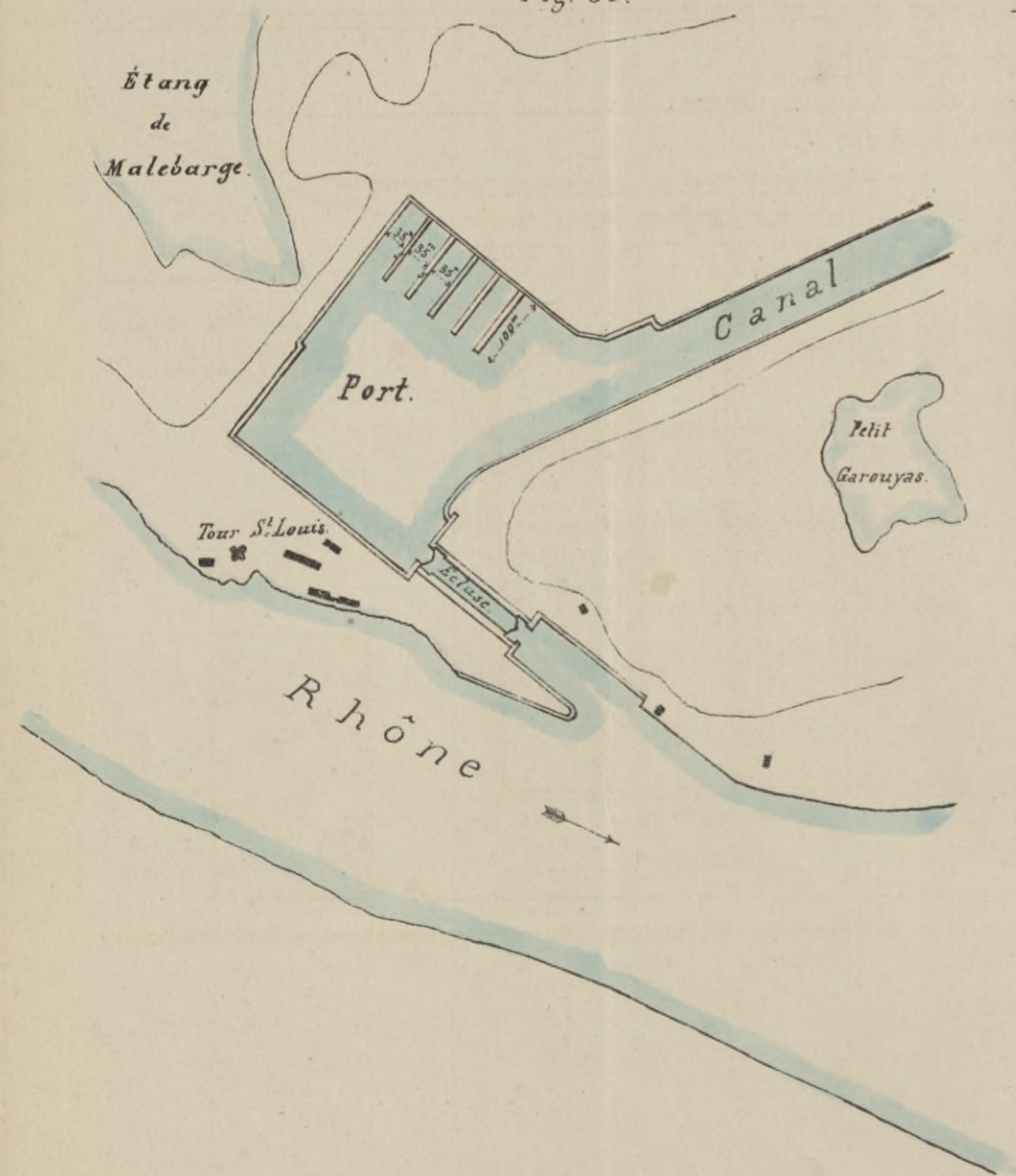



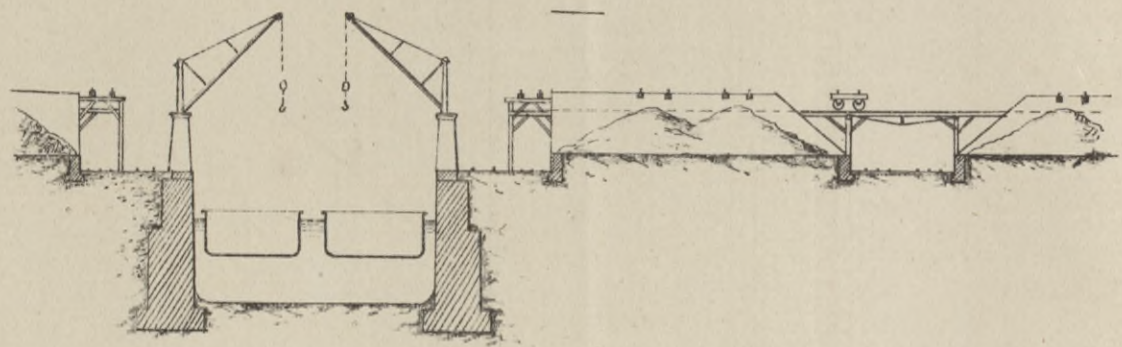



Fig. 95.

Disposition des estacades de débarquement.

Coupe transversale.



Plan.

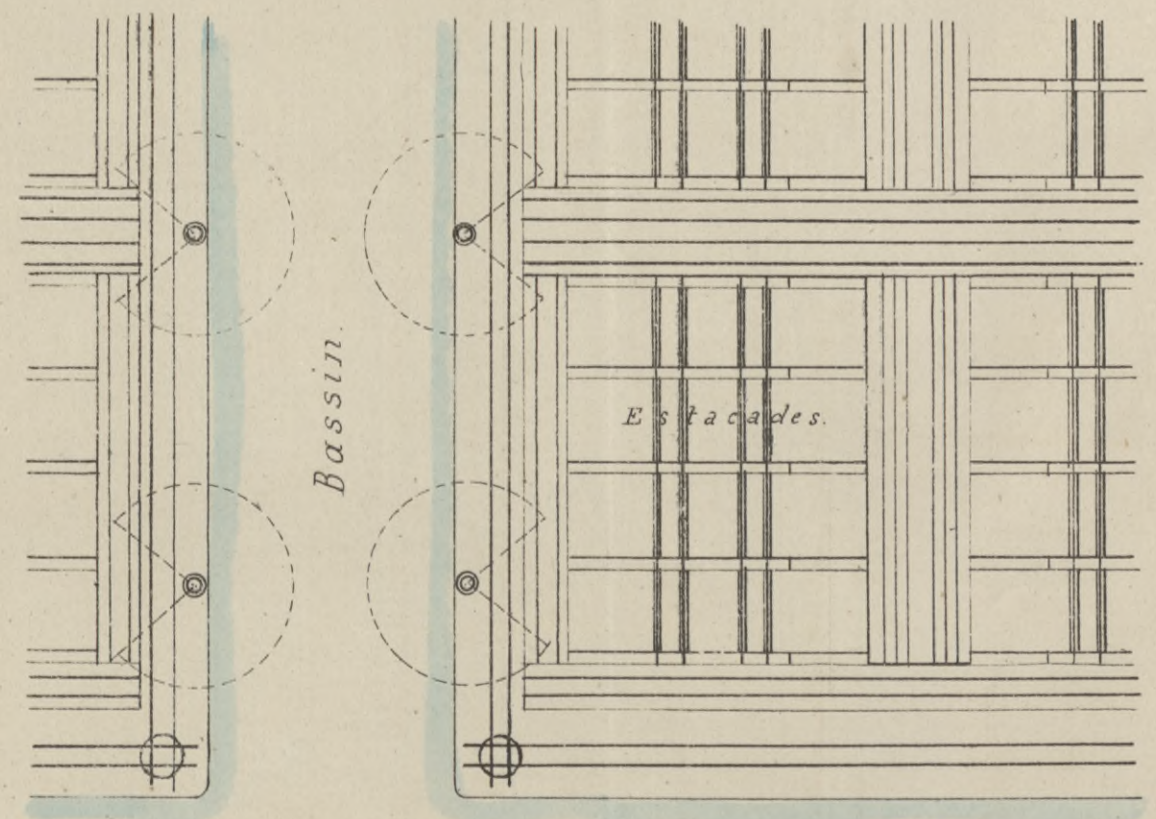

Échelle de 0.0025 par mètre.

Quai de transbordement des houilles sur le canal de la Sarre à Sarrebruck.

Coupe transversale.

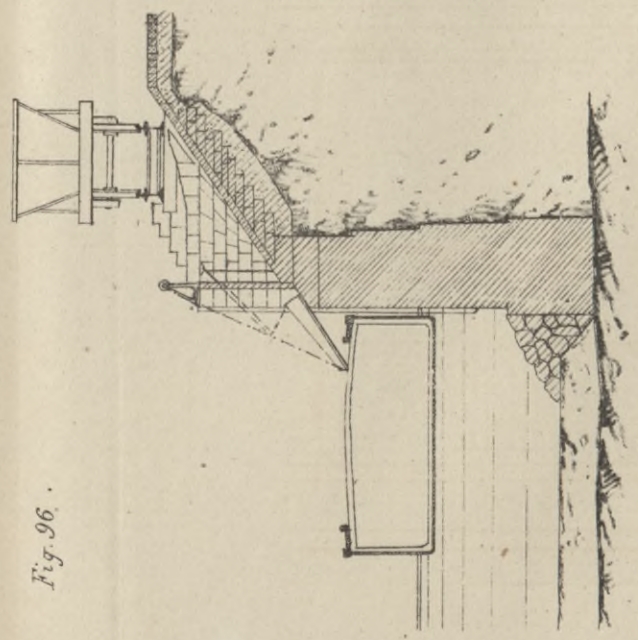

Fig. 96.

Élévation.

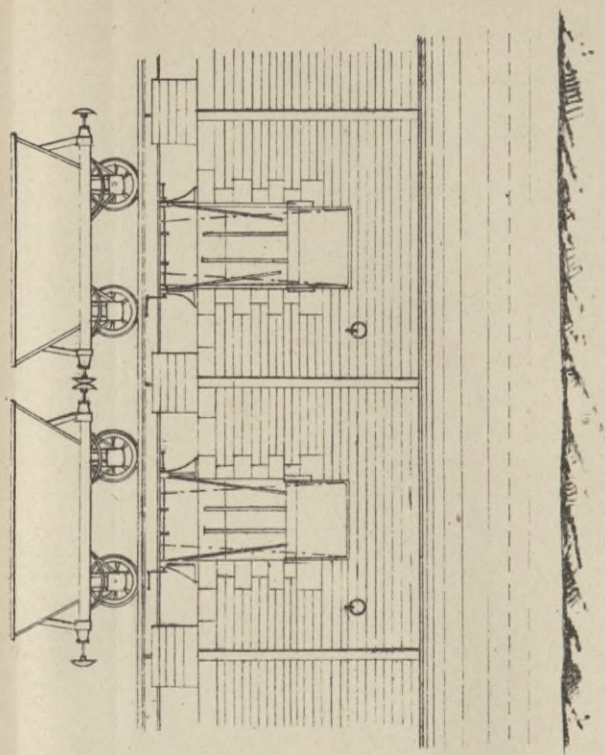

Fig. 97.

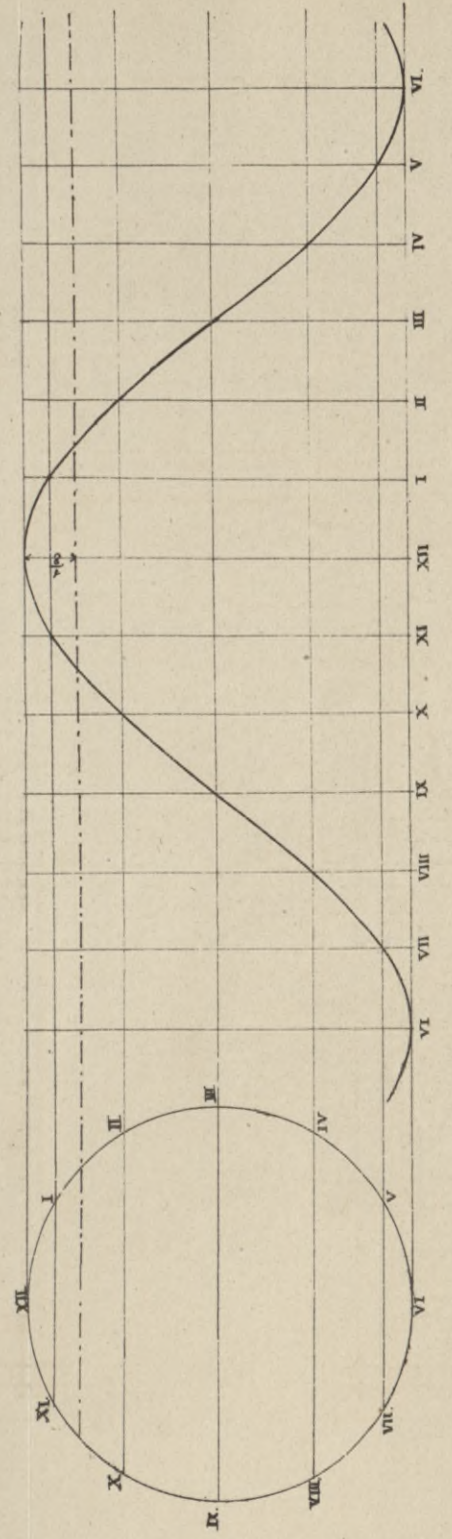





Fig. 98.

Tableau dressé par M<sup>r</sup> Chazallon en Novembre et Décembre 1839.

Courbes des Marées tracées d'après les observations faites aux syzygies en prenant partout pour unité l'amplitude totale.

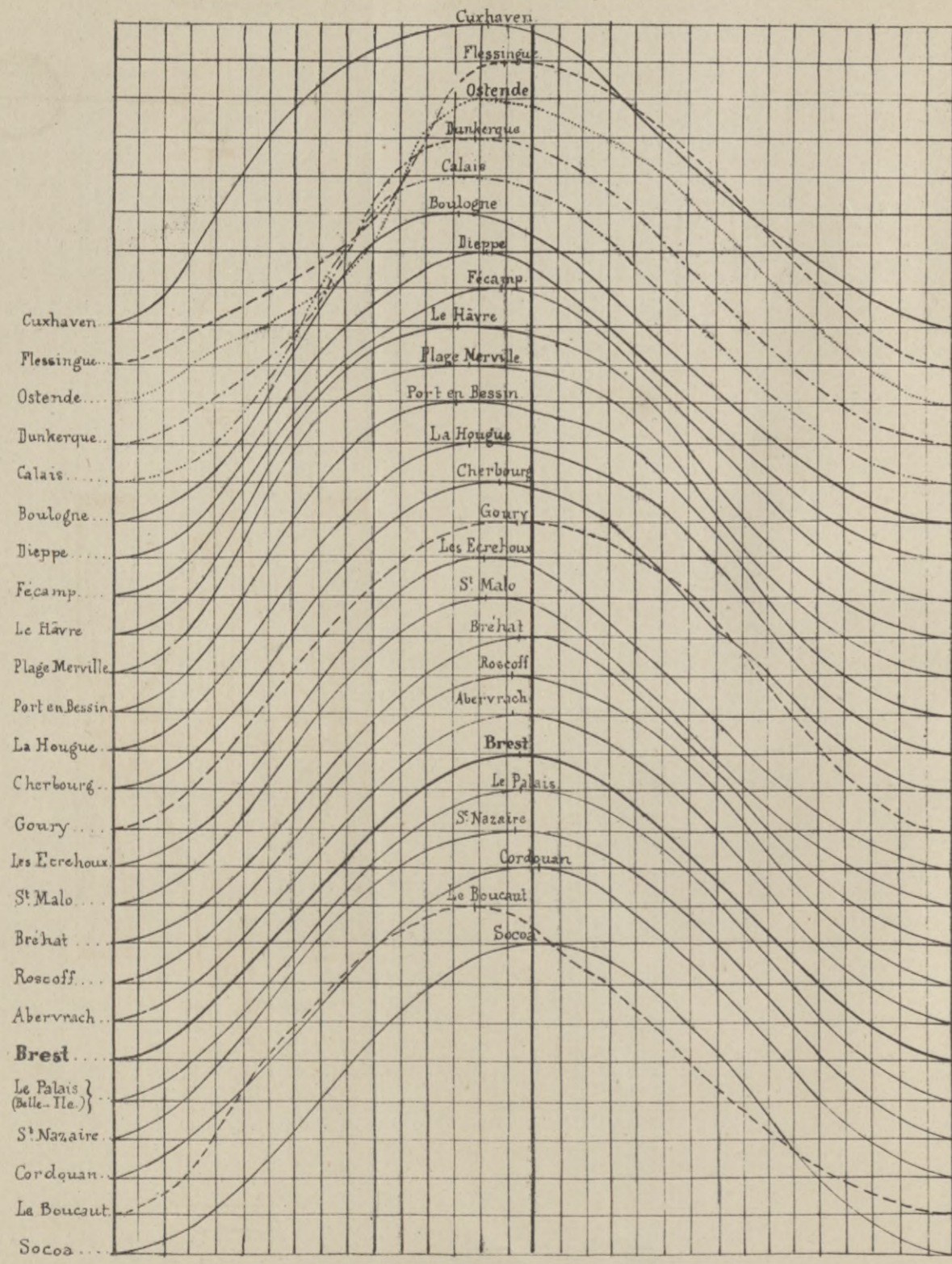

Fig. 100.

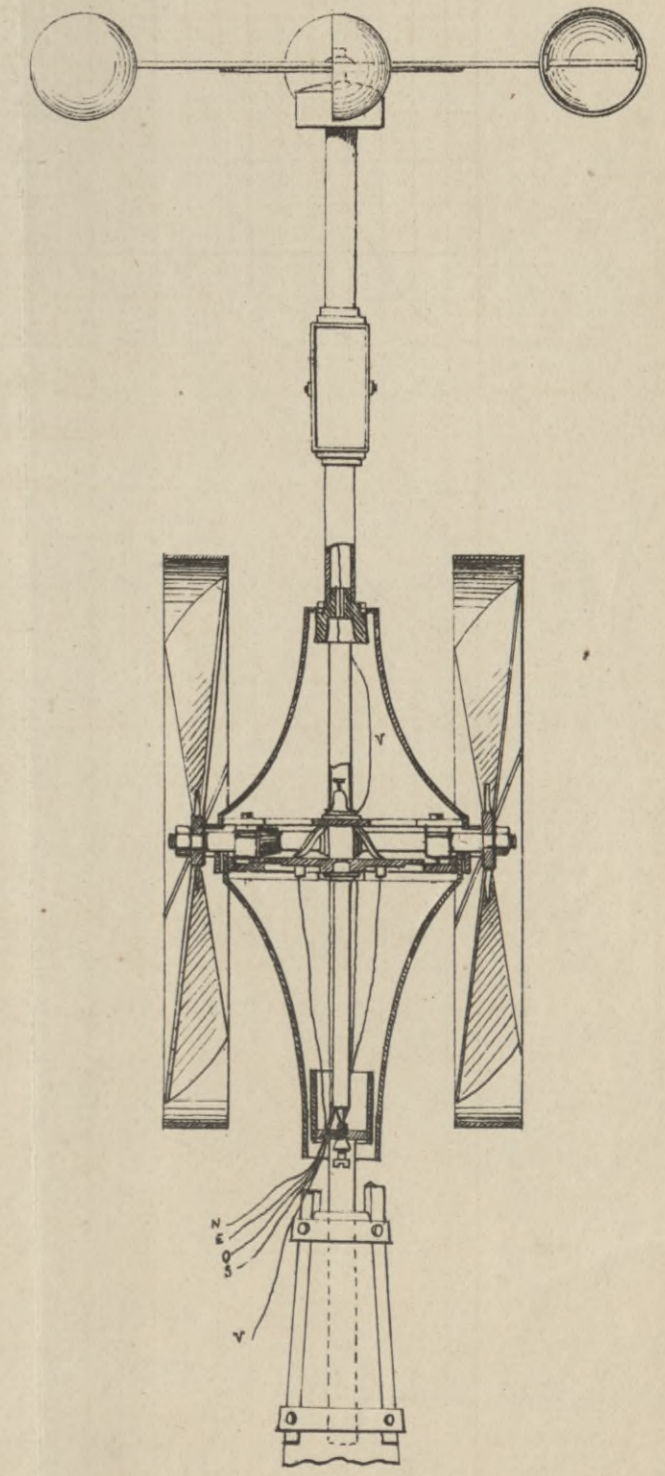
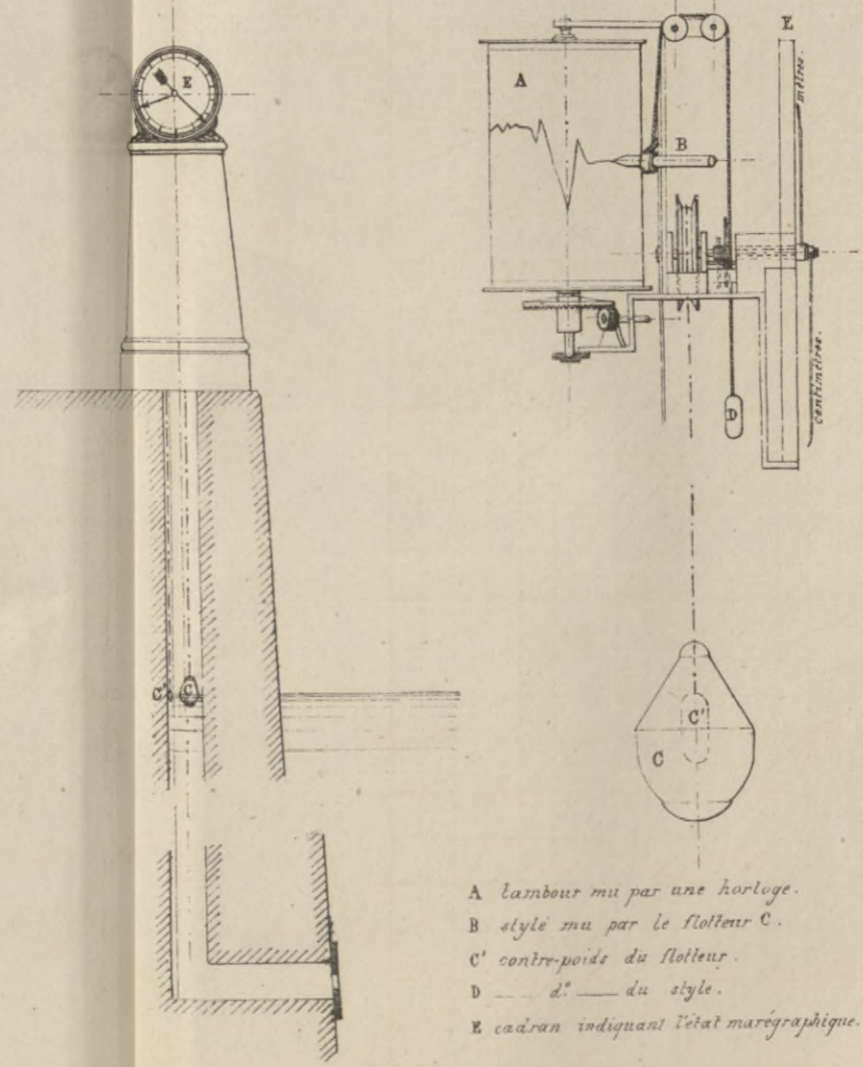

Fig. 99.



A lamour mu par une horloge.  
 B style mu par le flotteur C.  
 C' contre-poids du flotteur.  
 D — d. — du style.  
 E cadran indiquant l'état marégraphique.







Fig. 101.

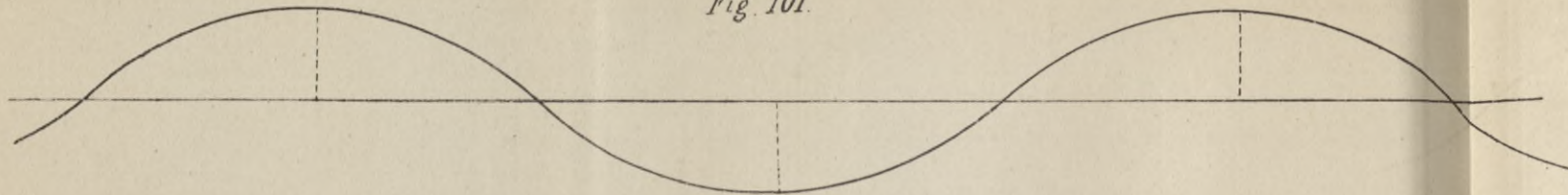

Fig. 104. Digue de Plymouth.



Coupe transversale de la digue.

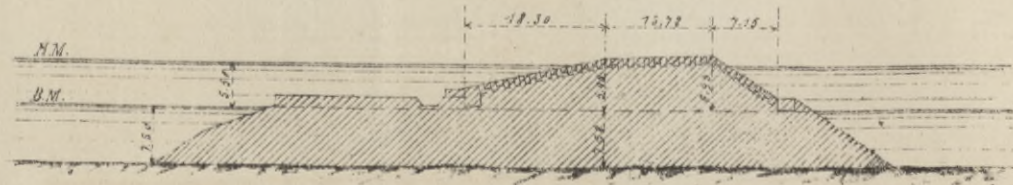

Fig. 102.

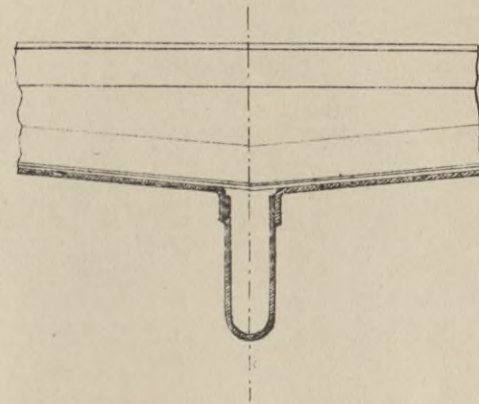

Fig. 103.

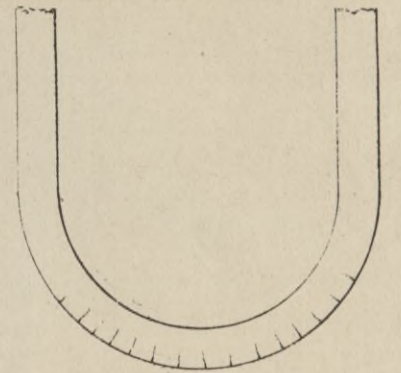

Fig. 105. Digue de Cherbourg.



Coupe transversale de la digue.

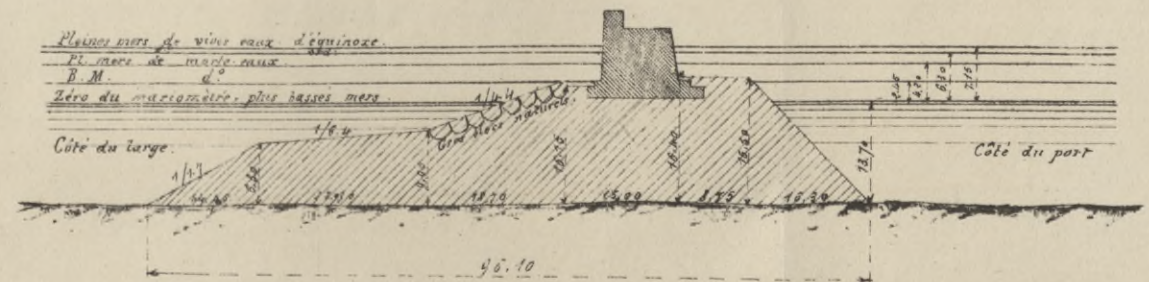





Fig. 106. Digue d'Holyhead.

Plan général.



Coupe transversale de la digue.

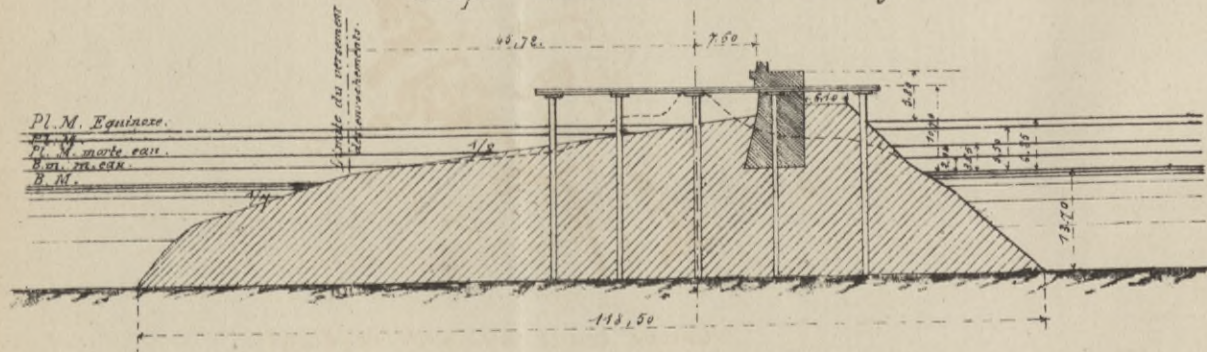

Fig. 107. Pont de service d'Holyhead.

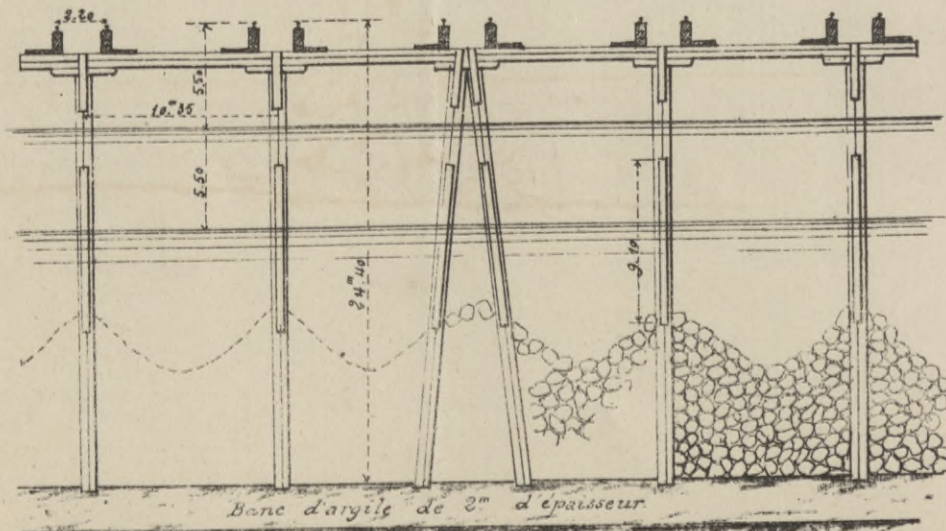

Fig. 108. Digue d'Alger.

Plan général du port.



Coupe transversale de la 1<sup>re</sup> partie de la digue.

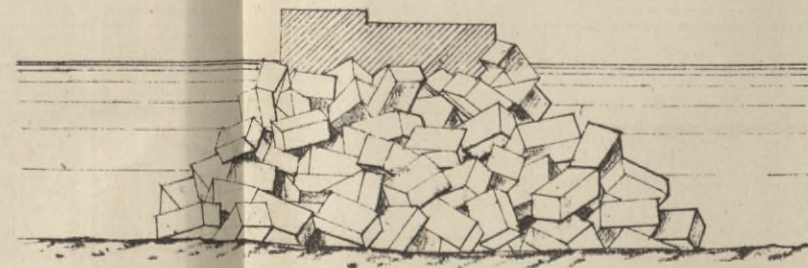

Fig. 110. Digue d'Alger (2<sup>e</sup> partie.)

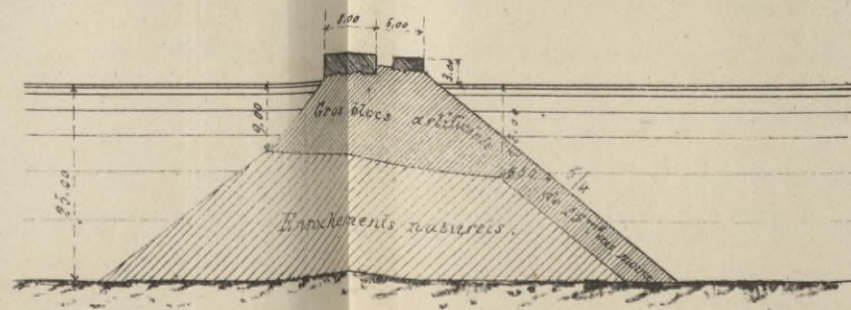

Fig. 109. Digue de Livourne.

Plan général.



Coupe transversale de la digue.

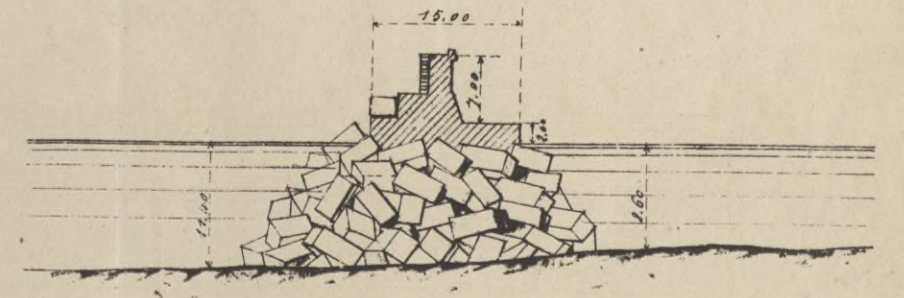
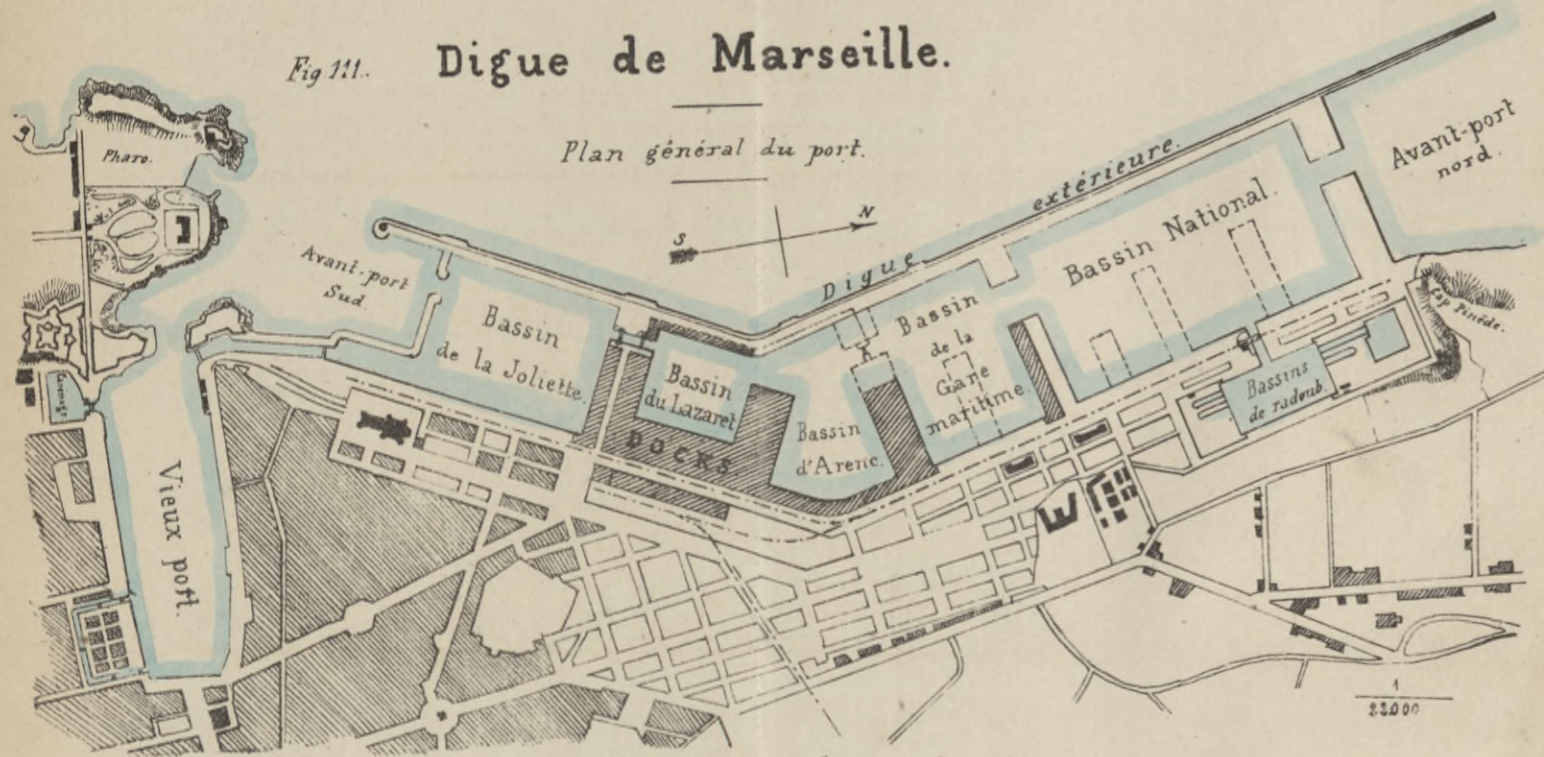





Fig 111. Digue de Marseille.



Coupe transversale de la digue.

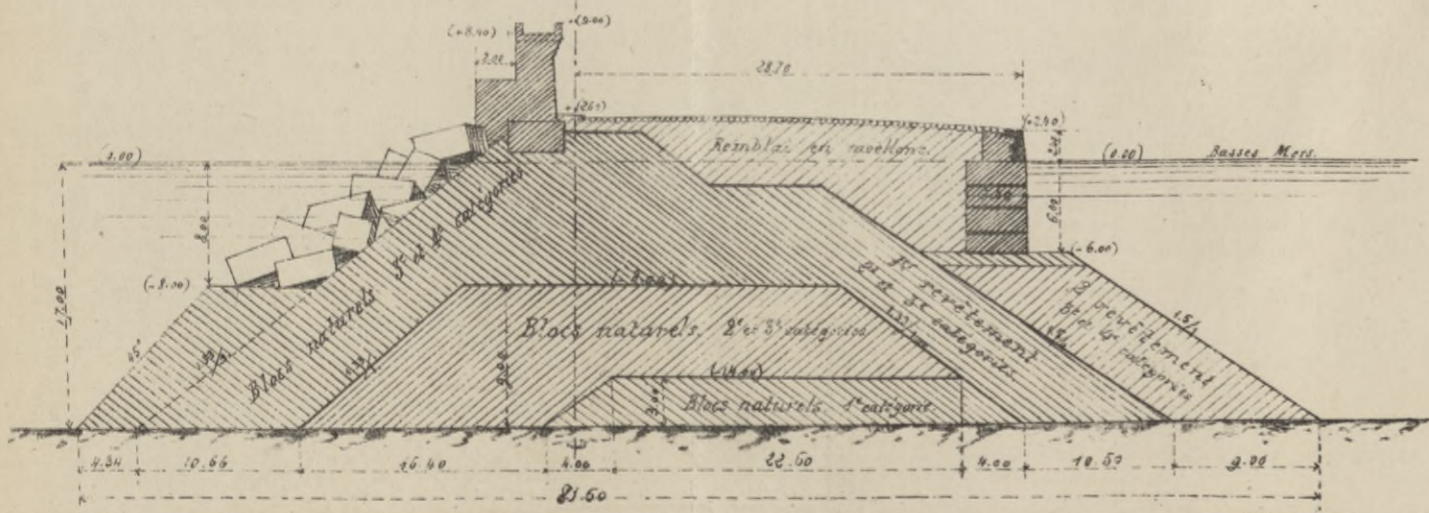

Fig 111 bis Digue d'Alderney.

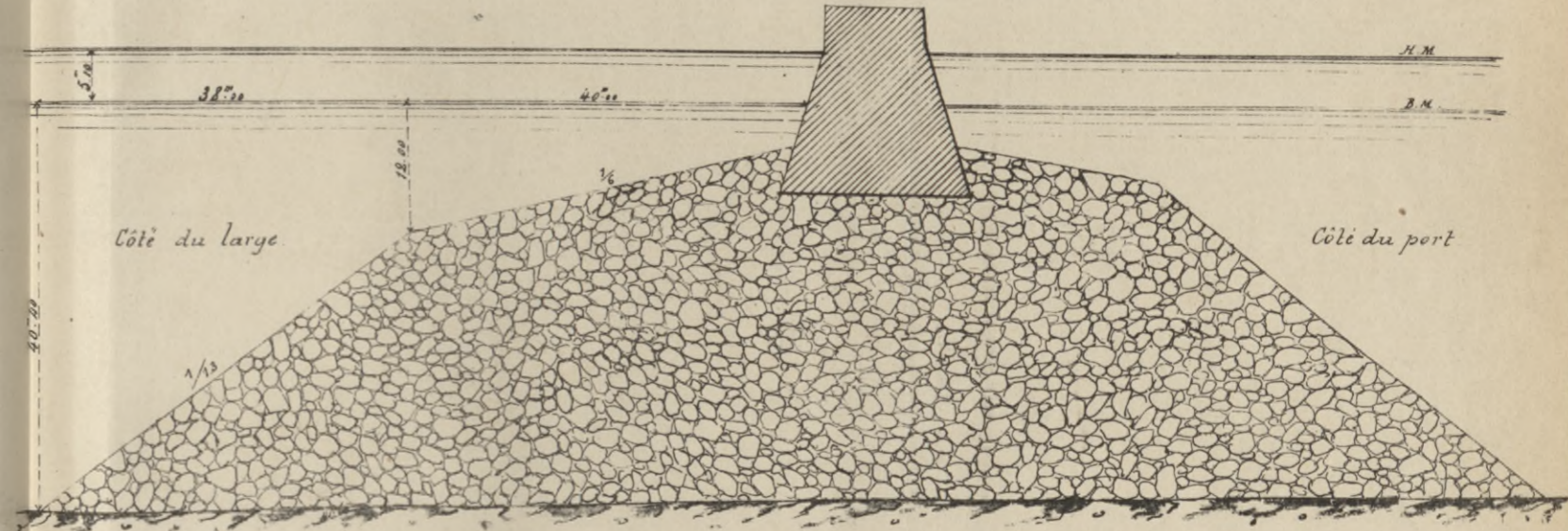

Fig. 112.

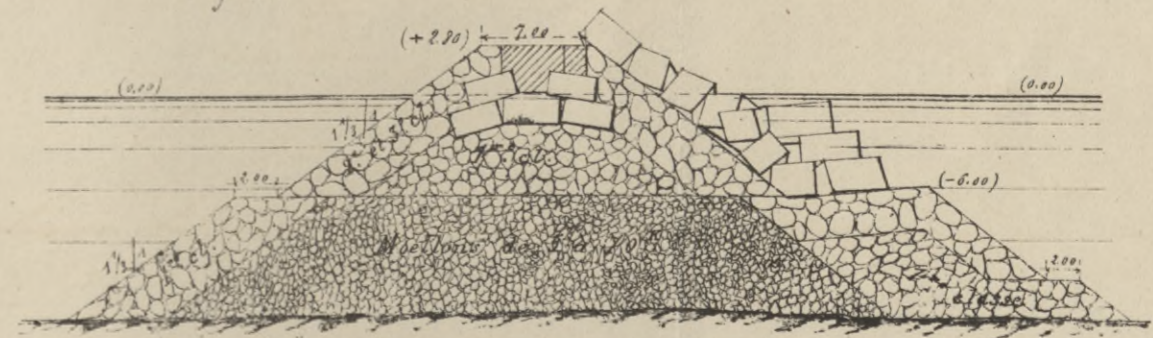







Fig. 113.

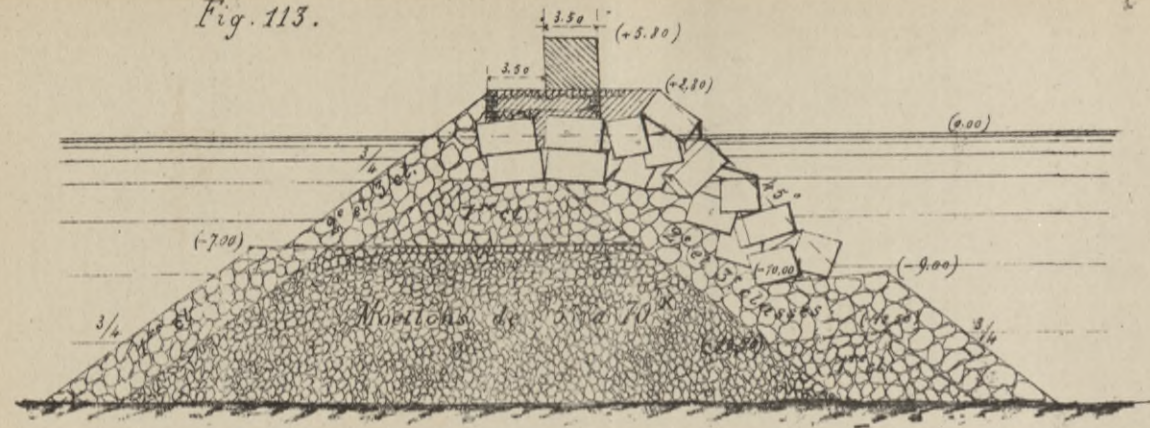
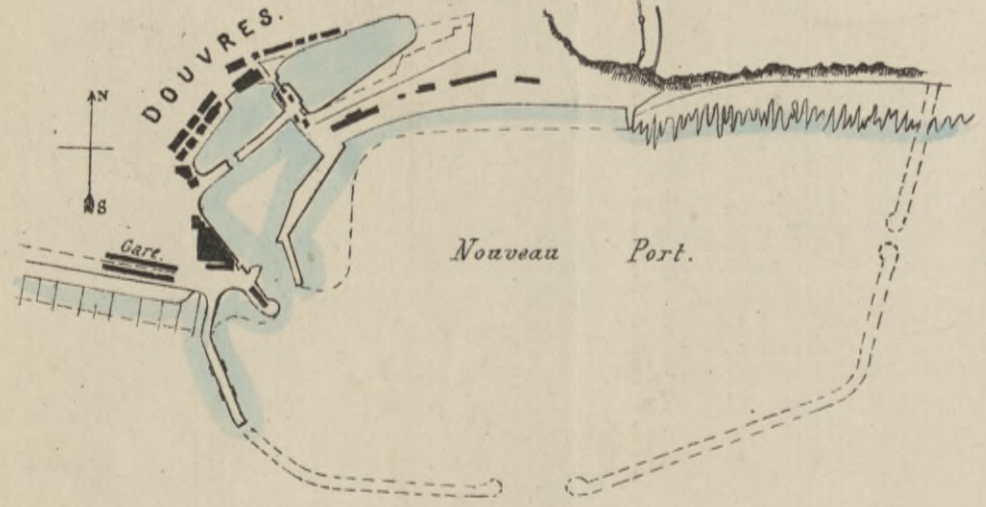

Fig. 114. Digue de Douvres.  
Plan général.



Coupe transversale de la digue.

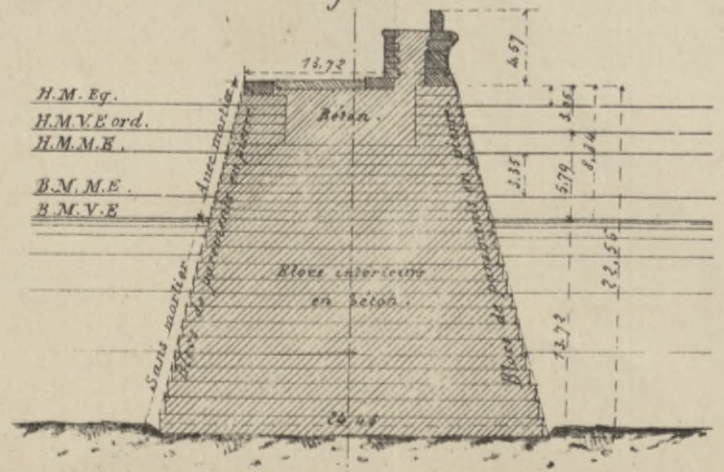
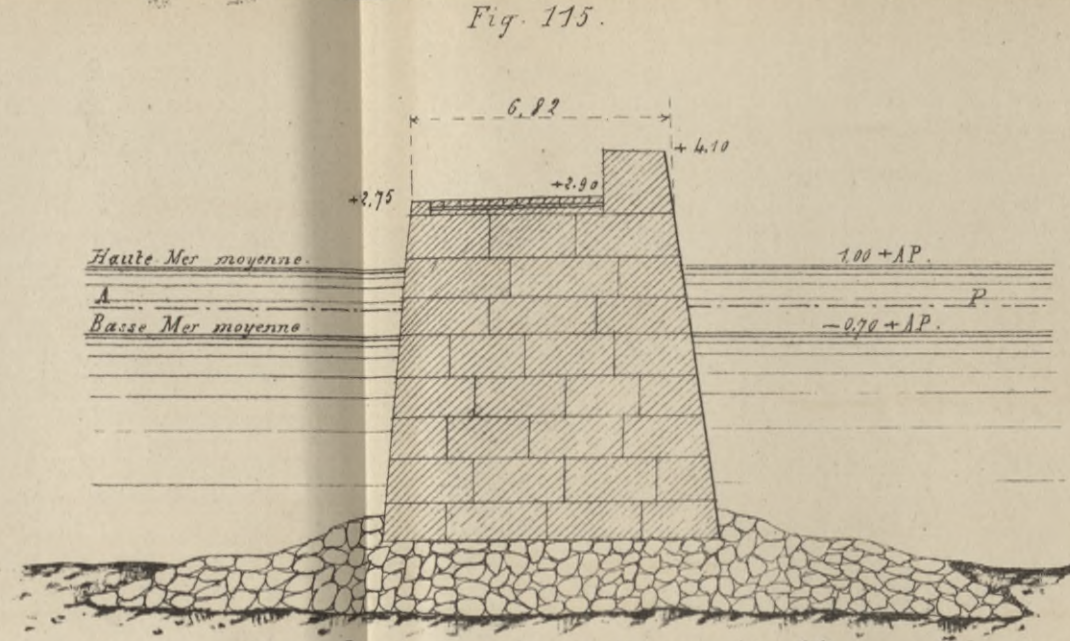

Fig. 115.



Nota. - Pour le plan d'ensemble, voir fig. 43.

Fig. 116.

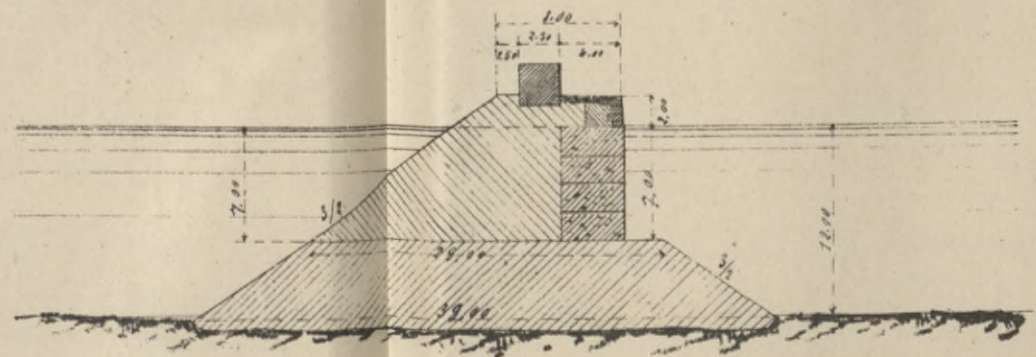

Fig. 117.

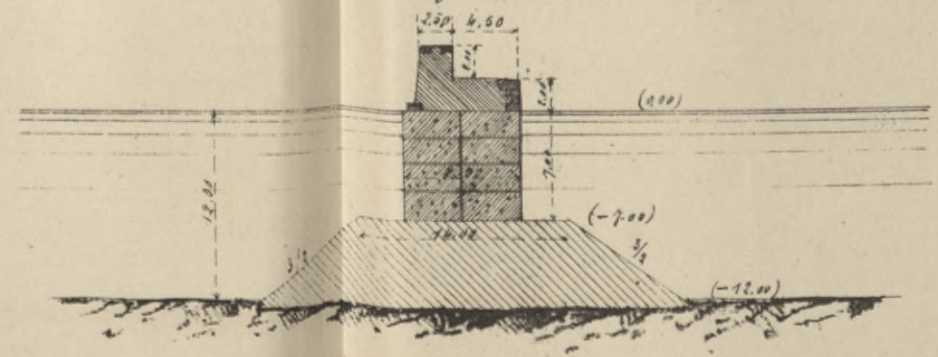

Fig. 118. Brise-lame flottant de la Ciotat.

Détail d'un flotteur.

Plan d'ensemble.

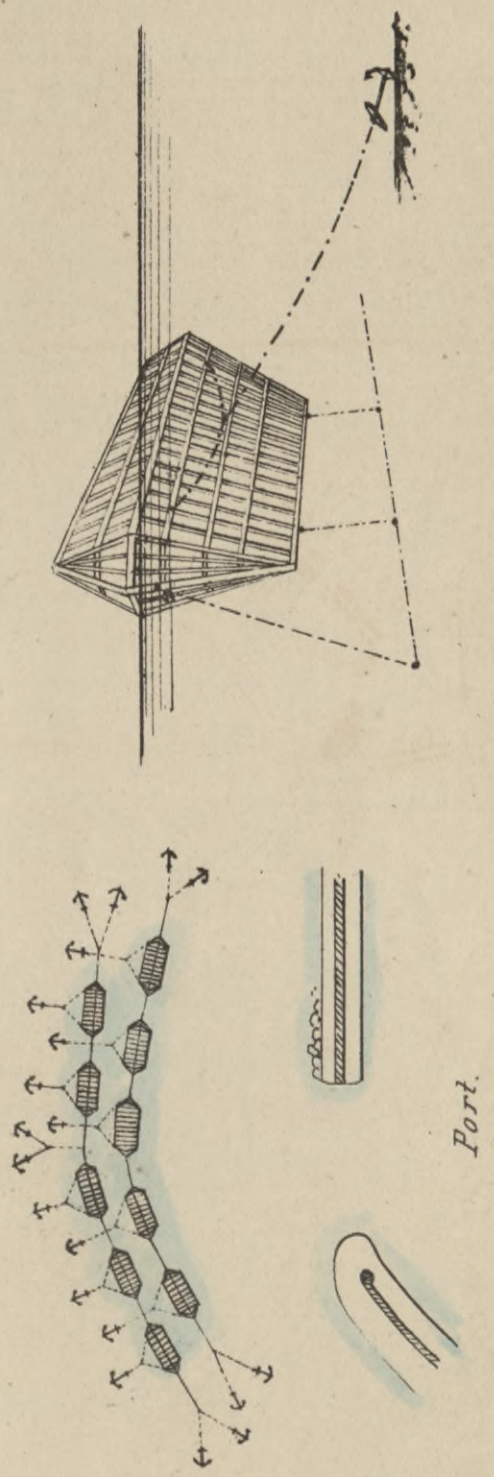





Fig. 119.

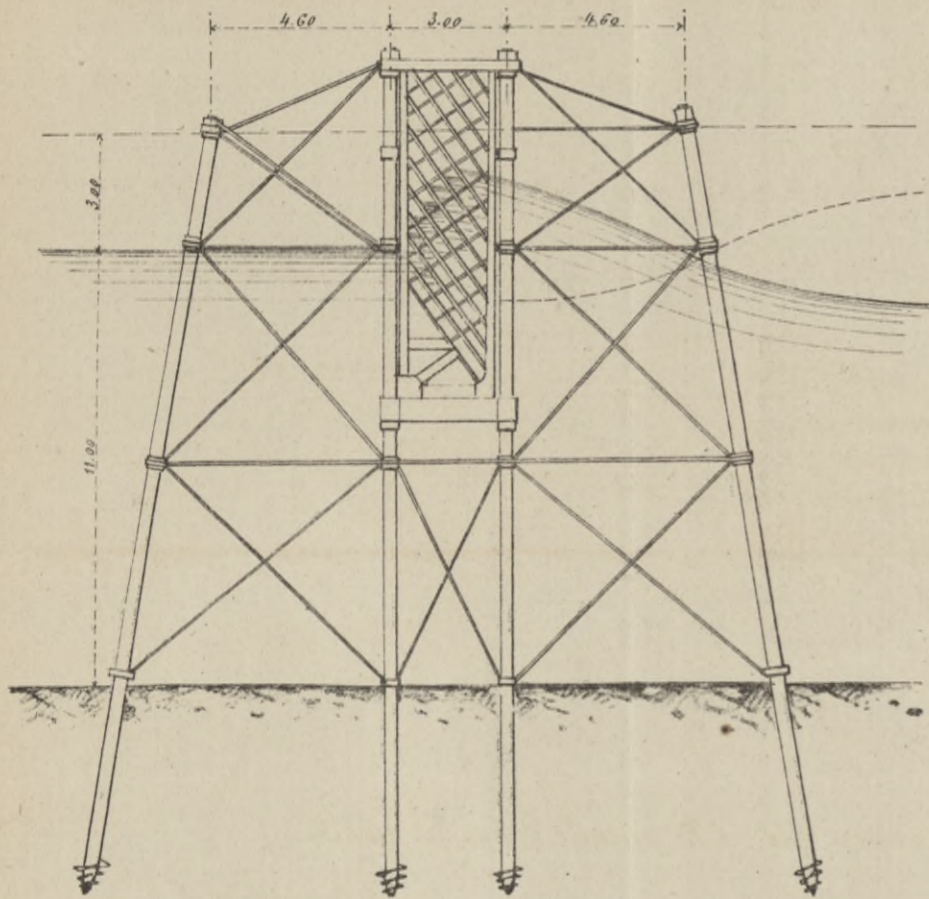

Fig. 120. Jetée Sud du Havre.

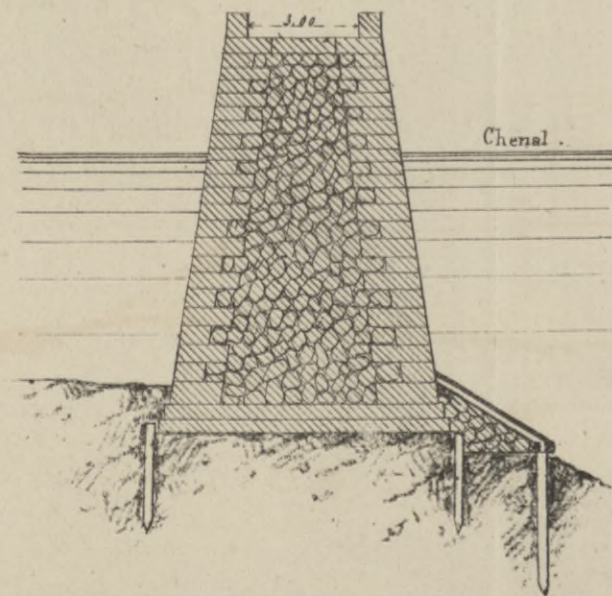

Fig. 121. Jetée de Boulogne.

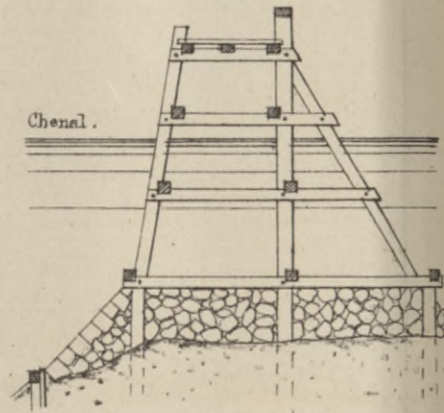

Fig. 122. Jetées de Soulina.

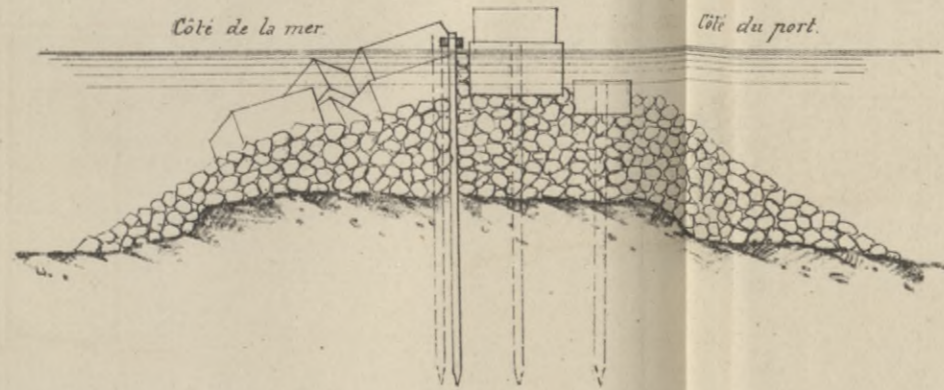

Fig. 123. Jetée Nord. (Hoek van Holland.)

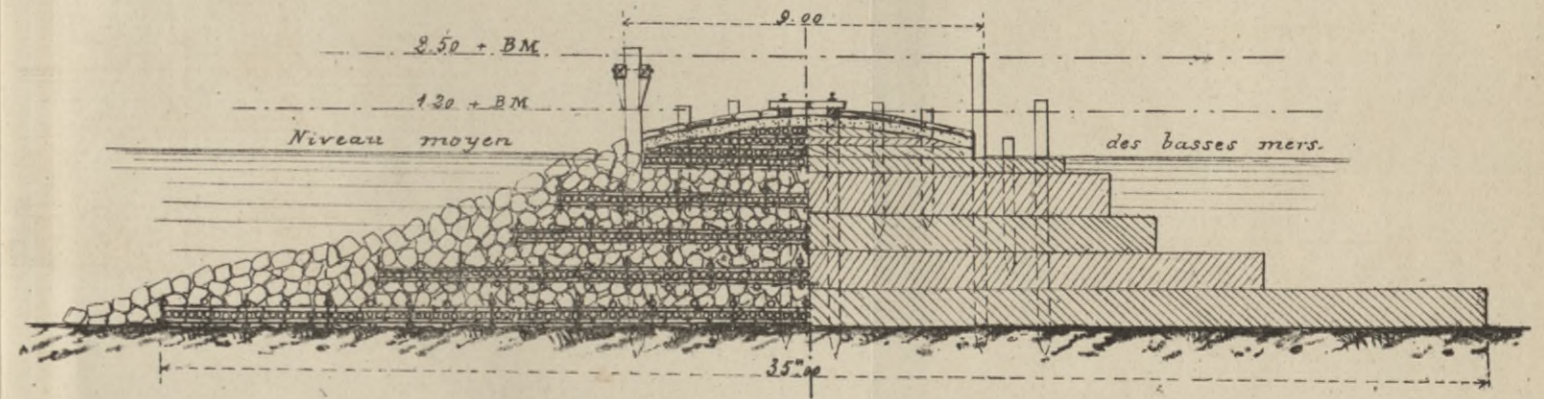

Fig. 124. Batardeau de l'Émeraude. (Docks de Marseille.)

Coupe en travers.

Plan général.

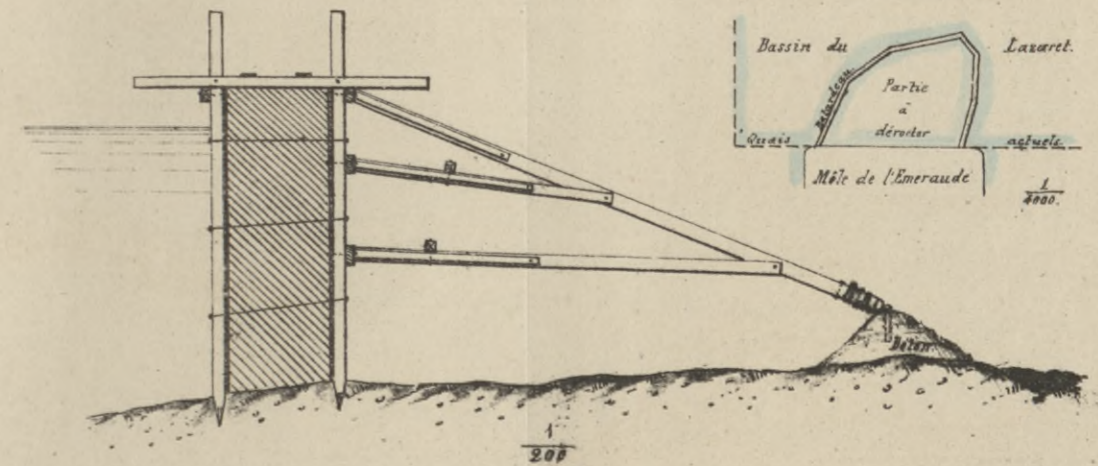





Fig. 126. Cloche à plongeur pour déroctements.

Fig. 125. Bâtardeau métallique des Docks Victoria.

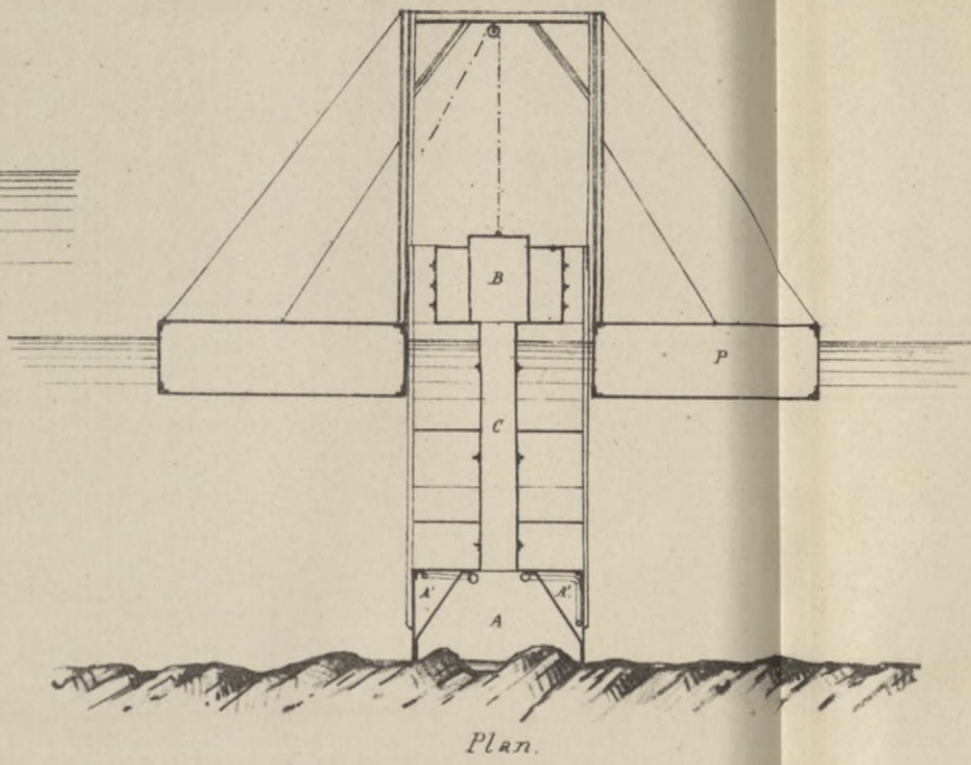
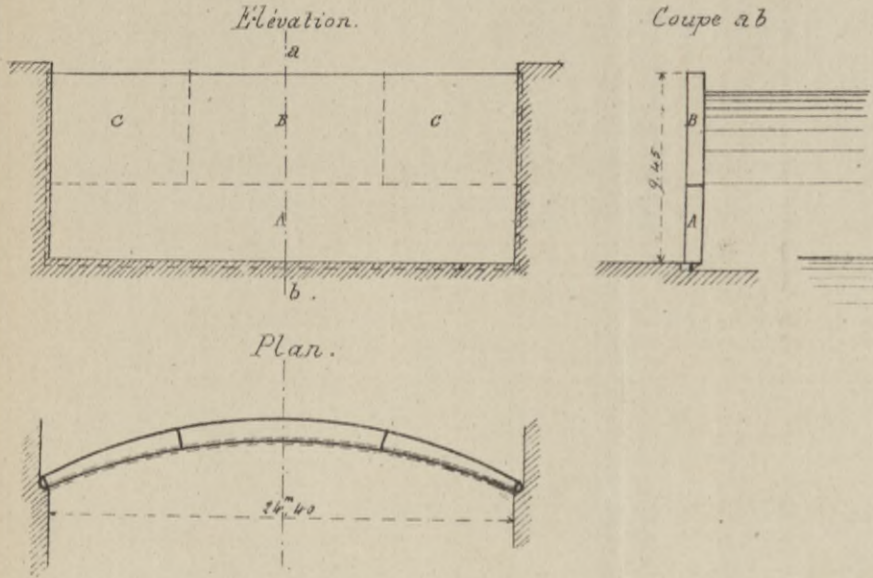

Fig. 127. Drague à vapeur.

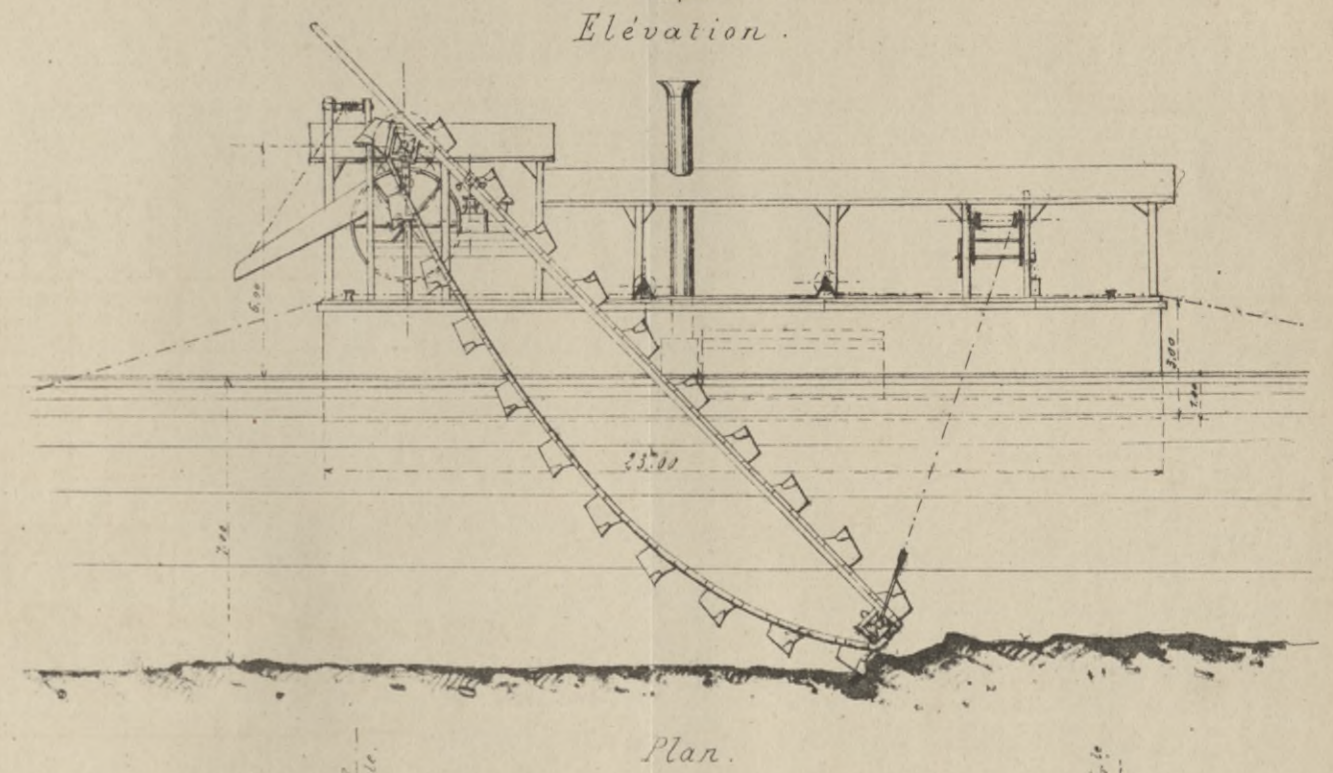

Fig. 128.

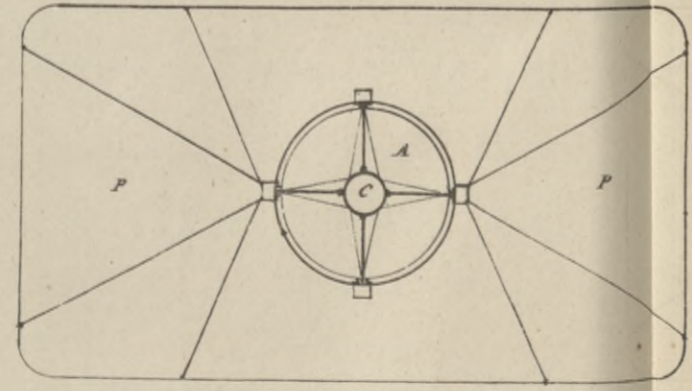

Fig. 129.

Écluse à sas de Hull.

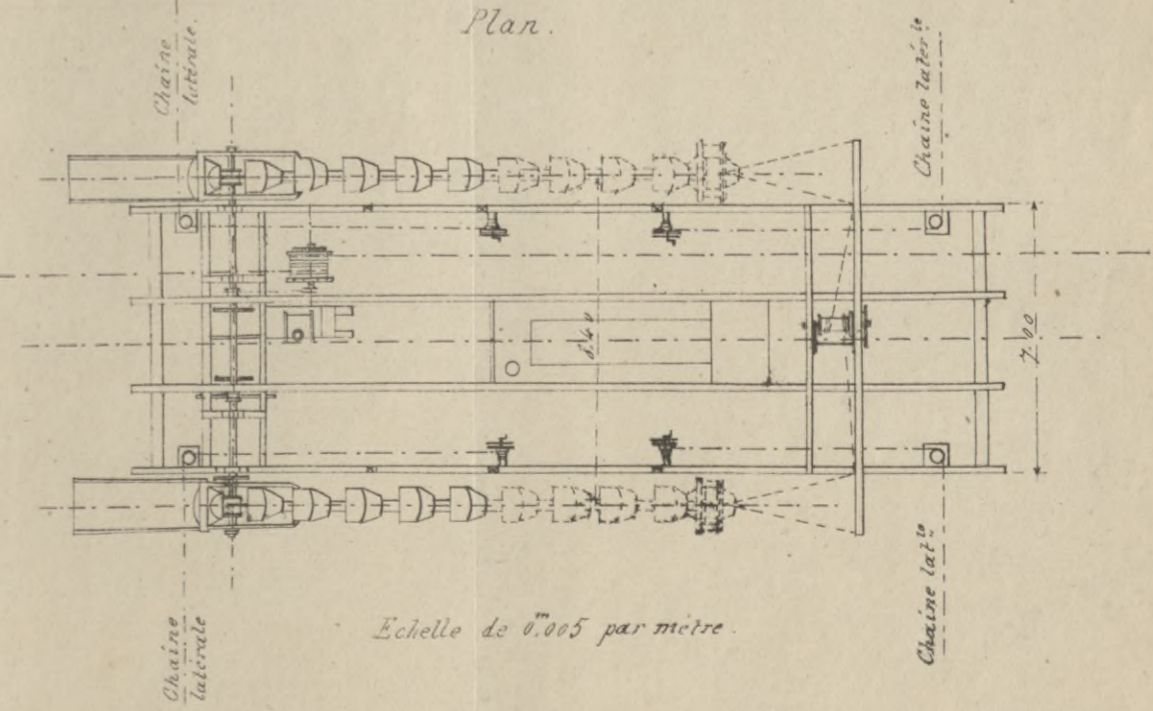
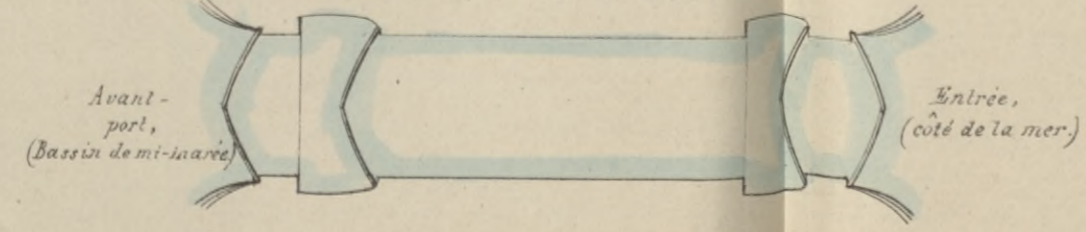







Fig. 130.  
Grande écluse du Havre.

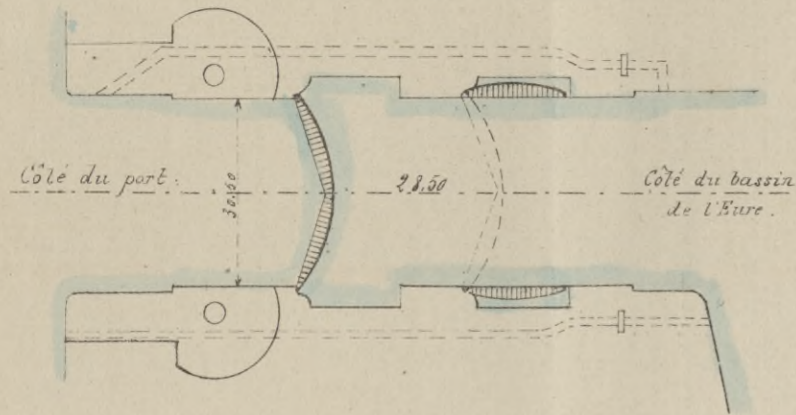

Fig. 131. Grande écluse du Havre.

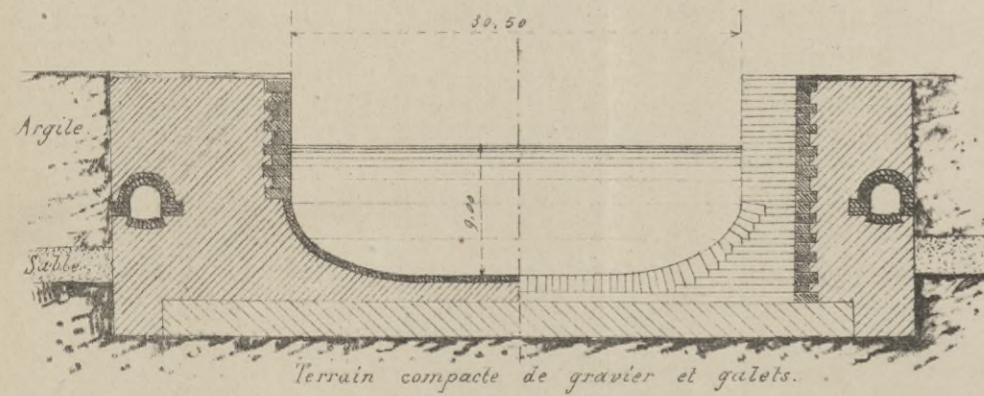
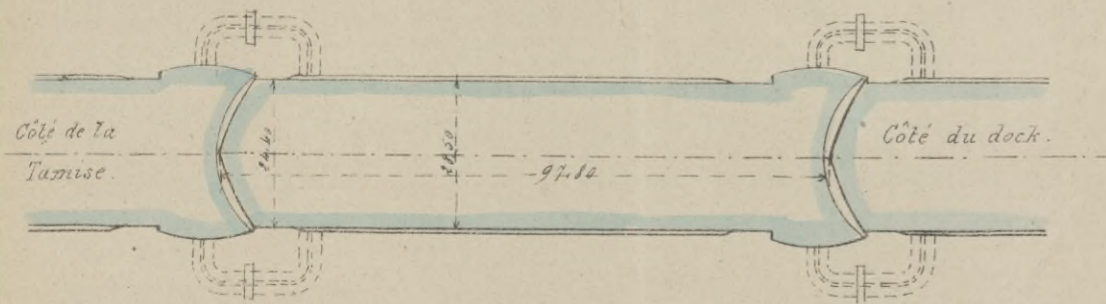
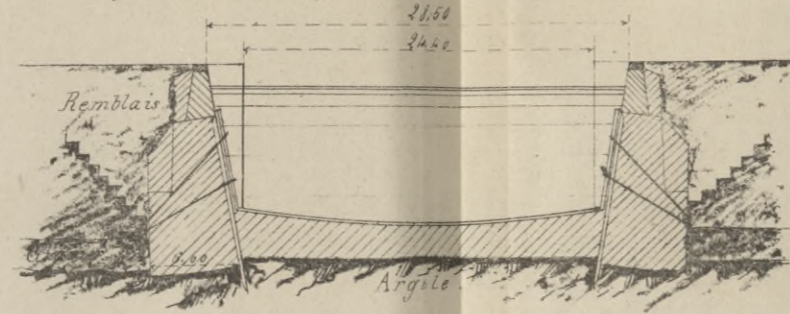

Fig. 132. Écluse des Docks Victoria.



Ecluse des Docks Victoria  
Fig. 133. Coupe transversale du sas.



Ecluse des Docks Victoria.  
Fig. 134. Section transversale aux portes.

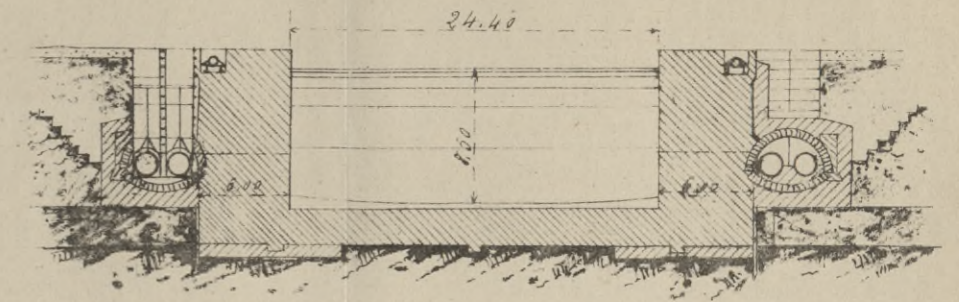

Fig. 135. Écluses des Docks de South-Shields.

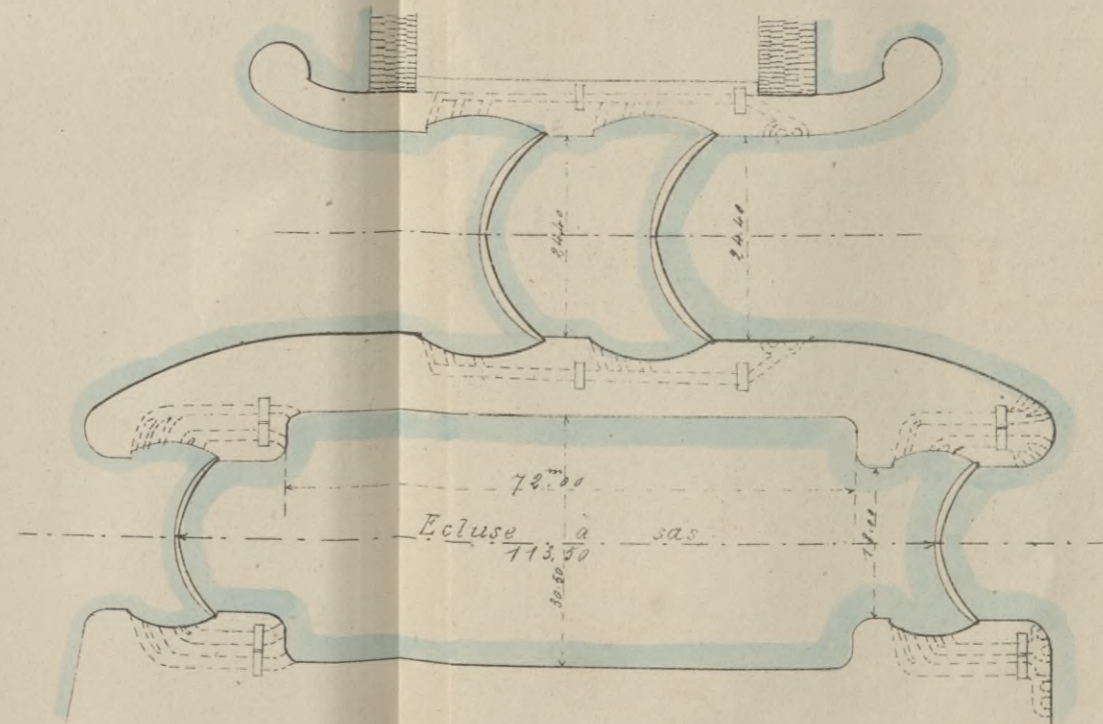

Fig. 136. Docks de South-Shields.

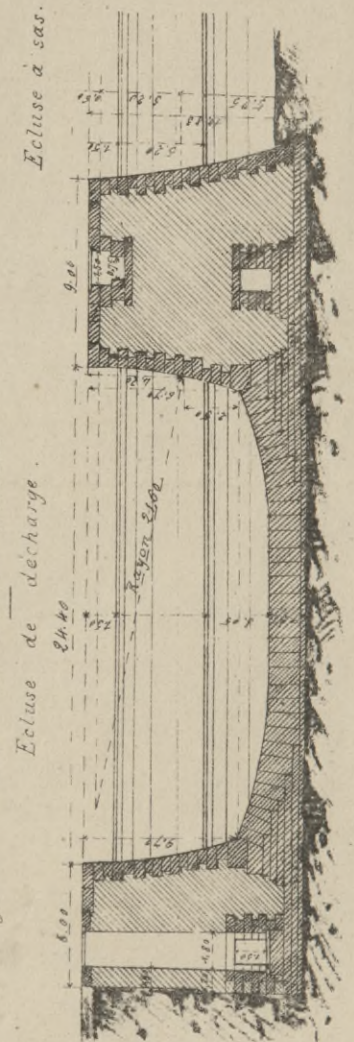





Fig. 137.  
Porte de l'écluse du bassin de la Barre-au Hâvre.

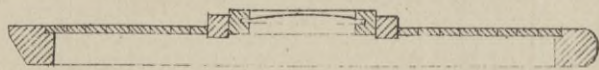
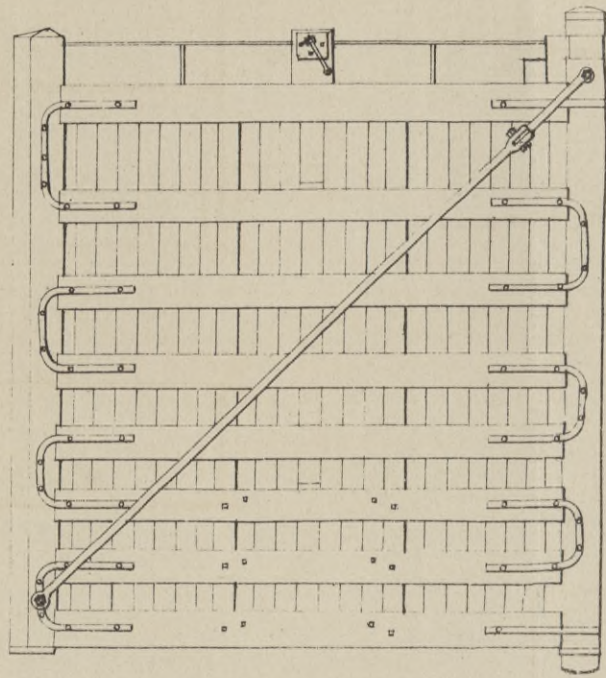

Fig. 138.

Porte en fer des Docks Victoria.

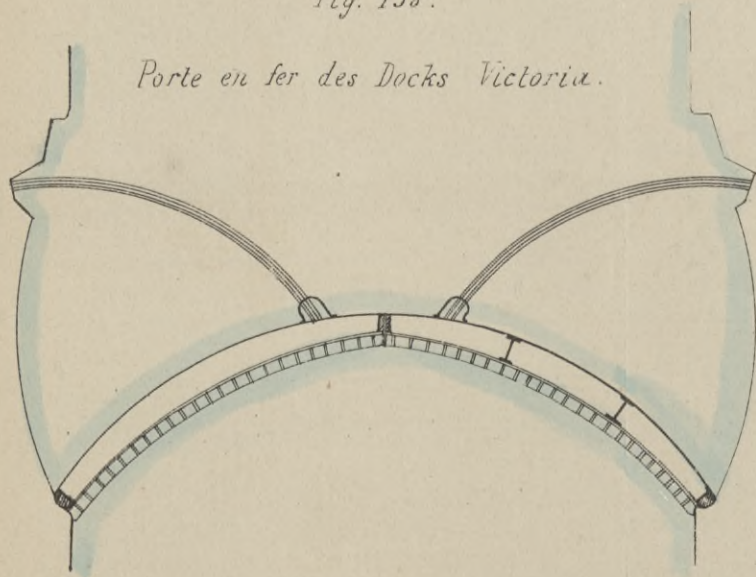
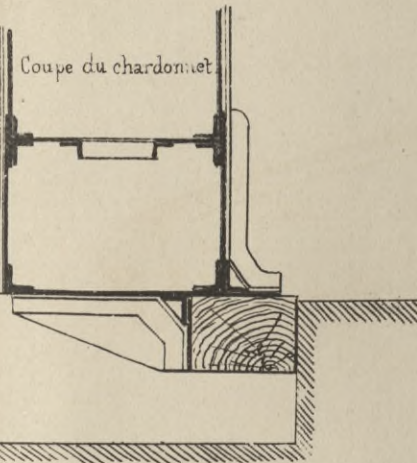
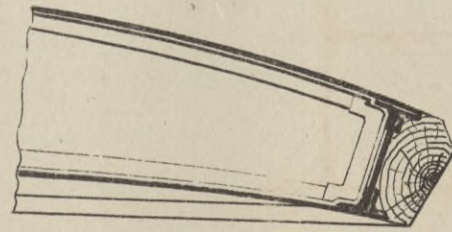

Fig. 139  
Coupe du poteau-busqué.



Coupe du chardonnet.

Fig. 142.

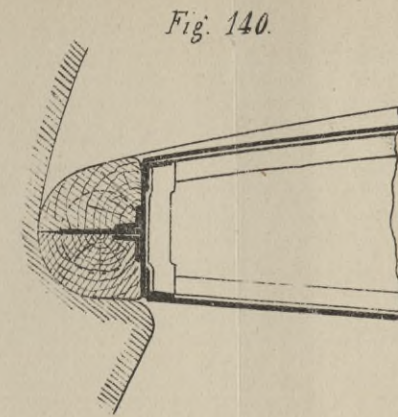
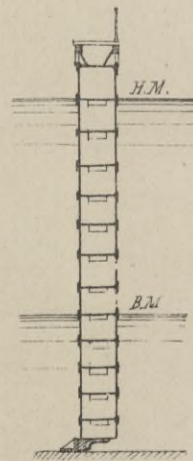
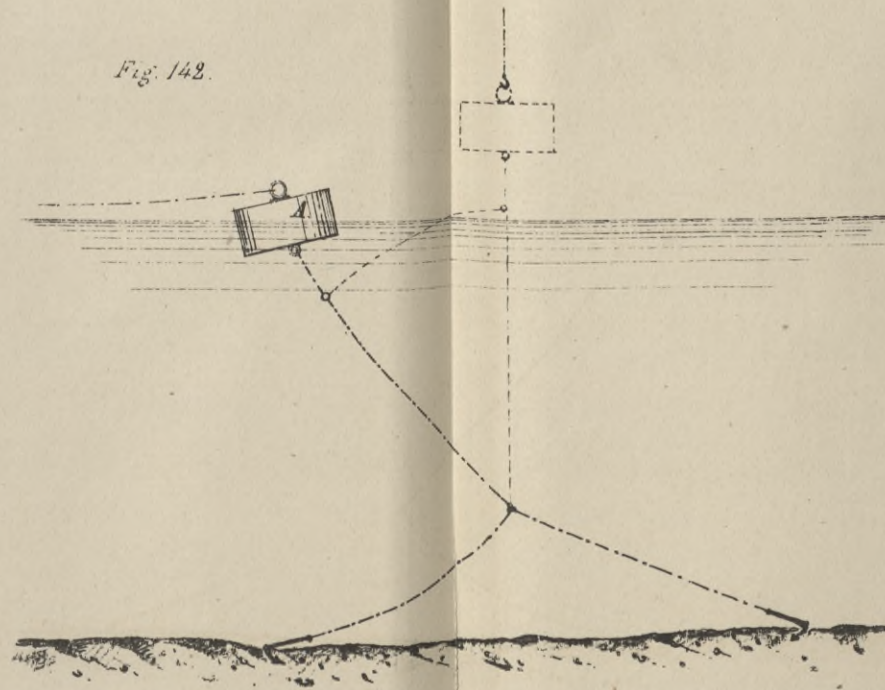

Fig. 140.

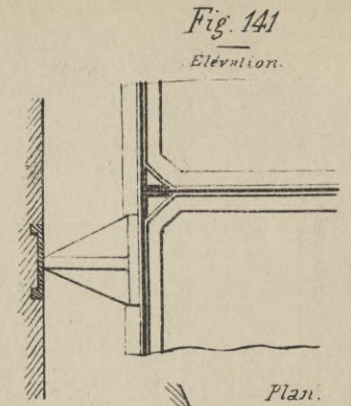

Fig. 141  
Elevation.

Plan.

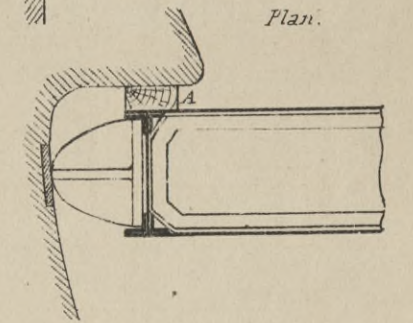
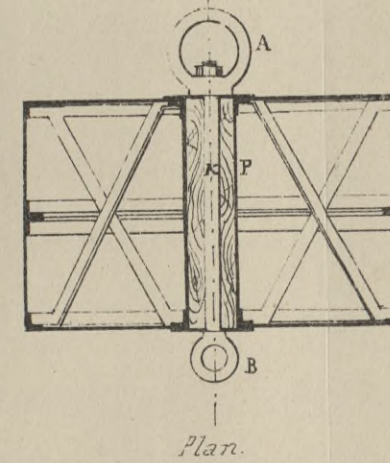
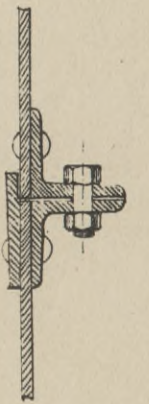
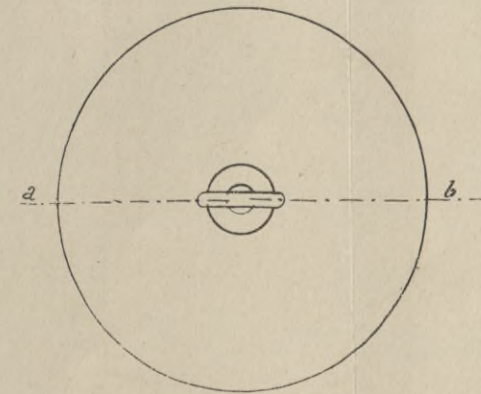

Fig. 143. Flotteur de bouée.  
Coupe ab.



Plan.

Fig. 144  
Détail du joint  
pour flotteur démontable.



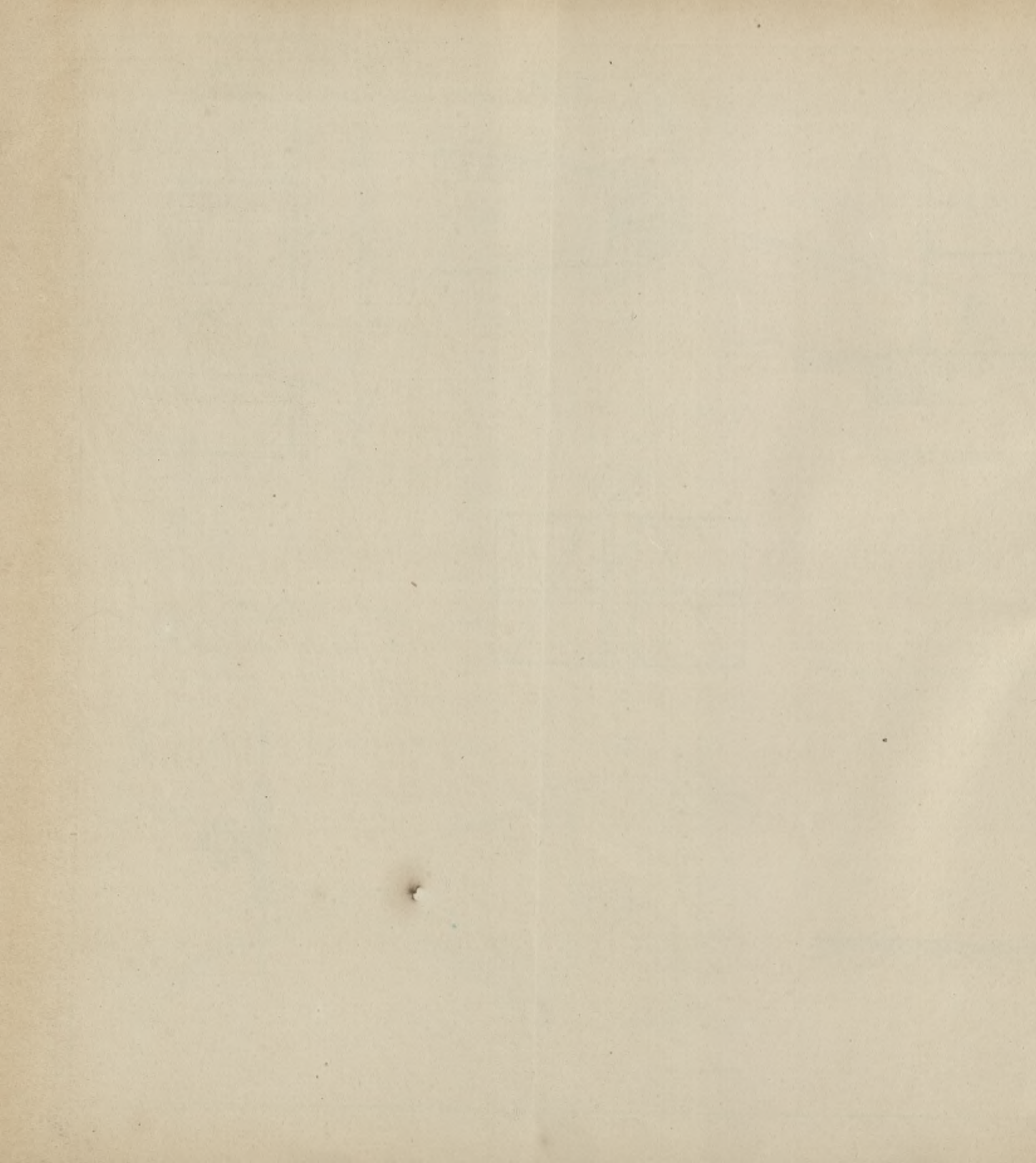

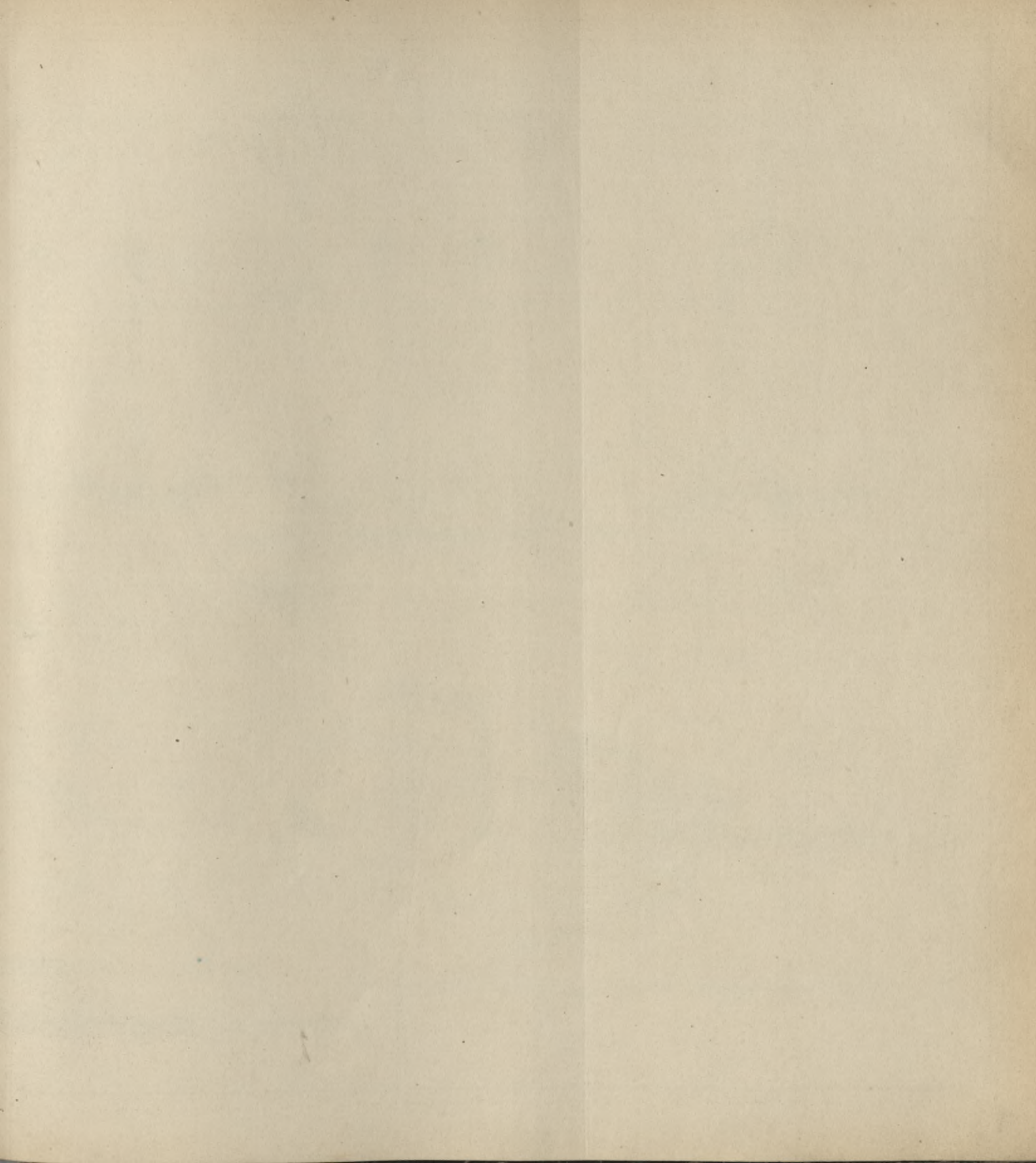



Fig. 145.  
Ancre de bouée.

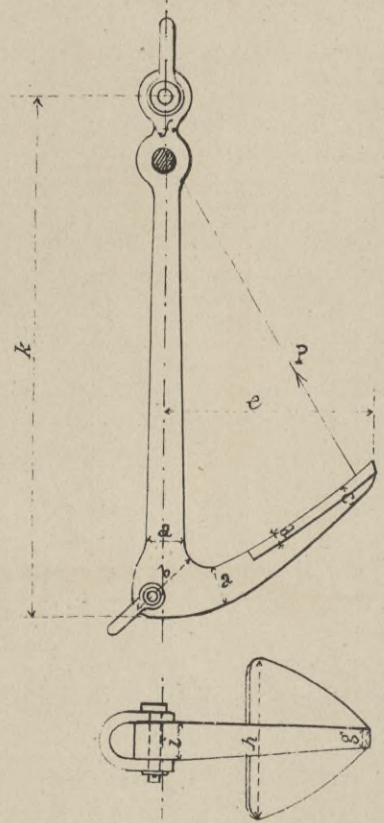

Fig. 146. Bouée à voyant.

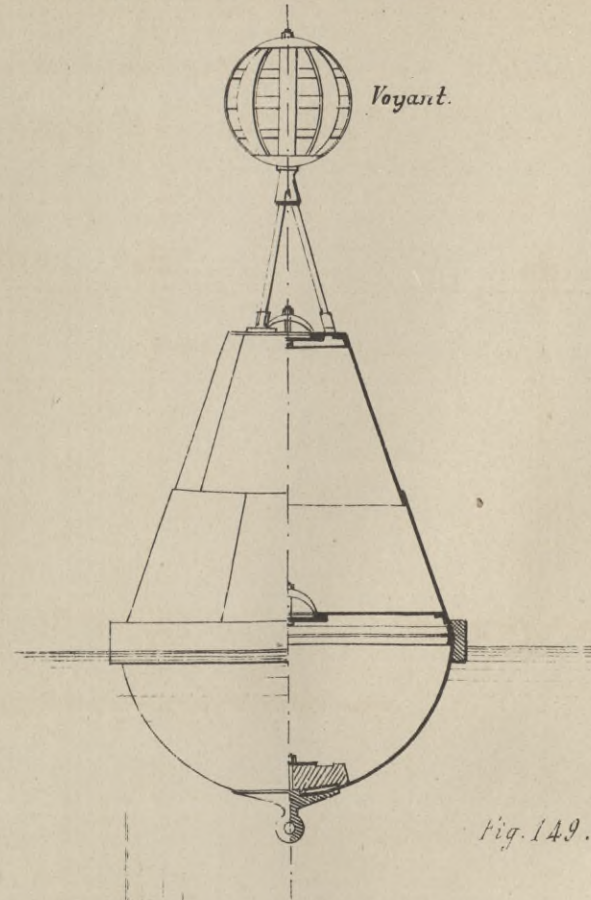
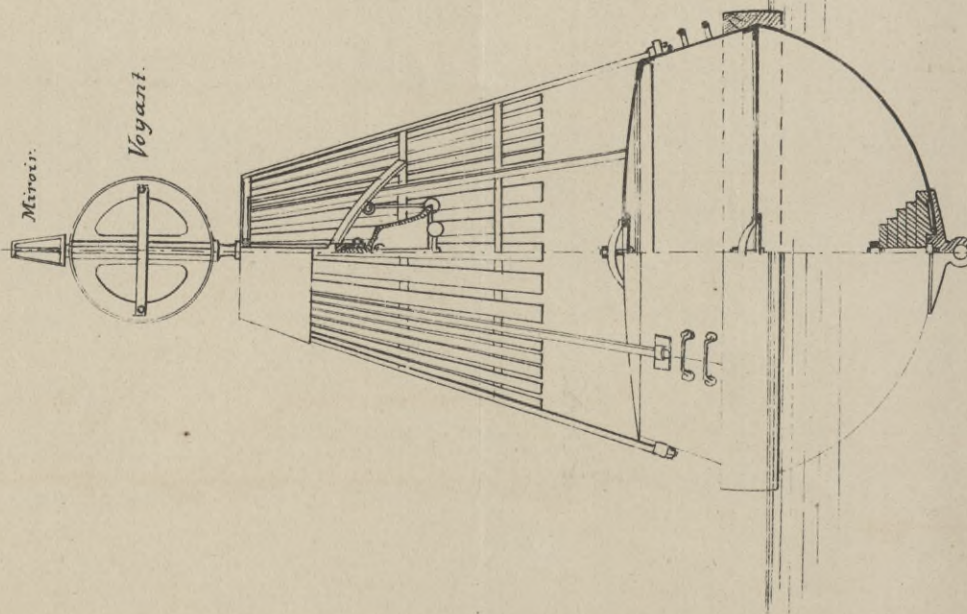
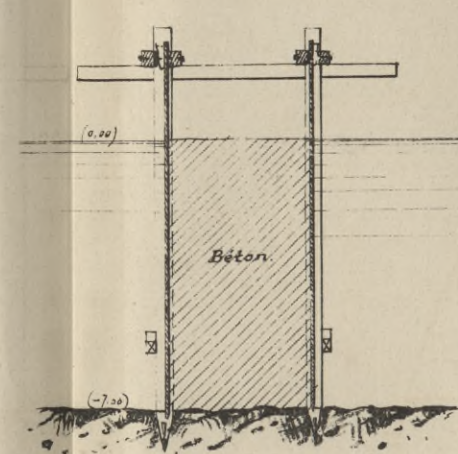

Fig. 149.

Fig. 147. Bouée à cloche.



a. Mur en béton coulé  
par des fonds de 7<sup>m</sup>.



b. Mur en béton coulé  
par des fonds de plus de 8<sup>m</sup>.

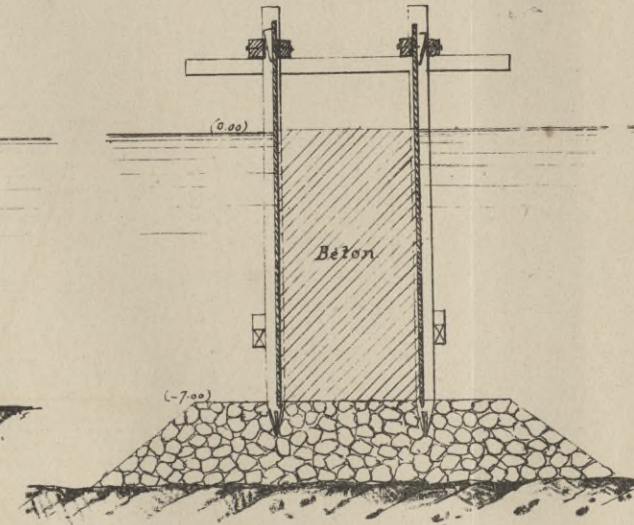

c. Mur de quai  
en béton coulé, avec revêtement.

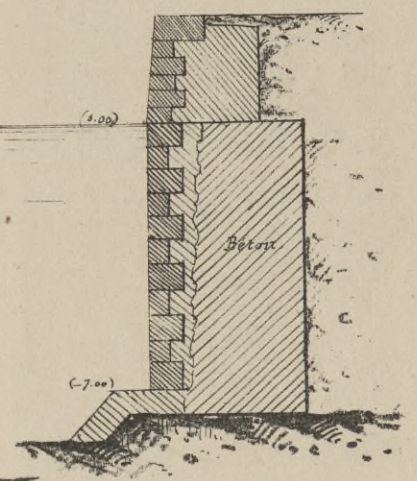

Mur de quai  
avec massif de fondation  
en blocs artificiels.

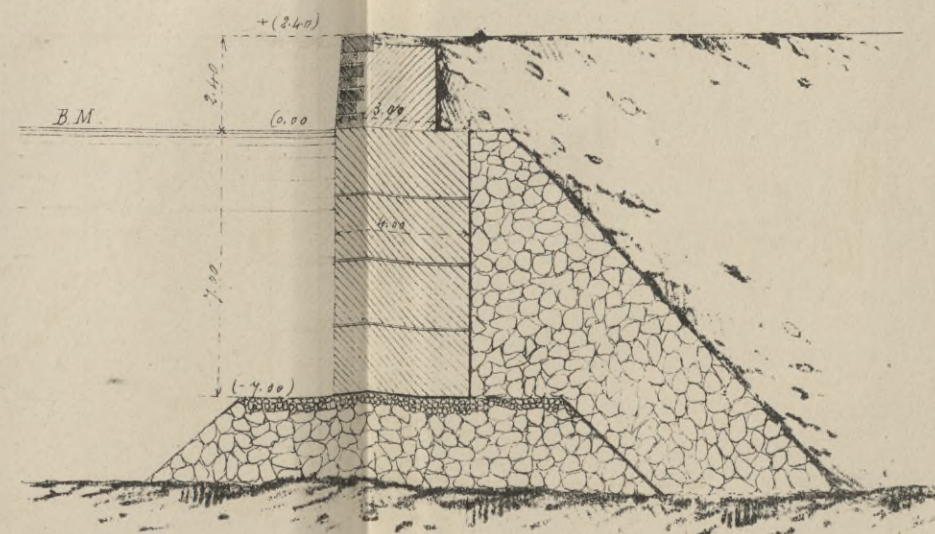

Fig. 150. Murs de quai de Marseille (Docks).

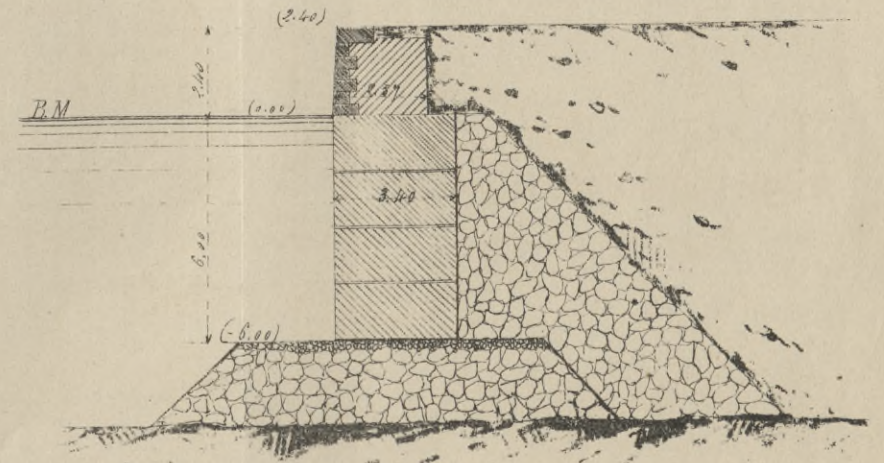





Fig. 151. Quais de Dublin.

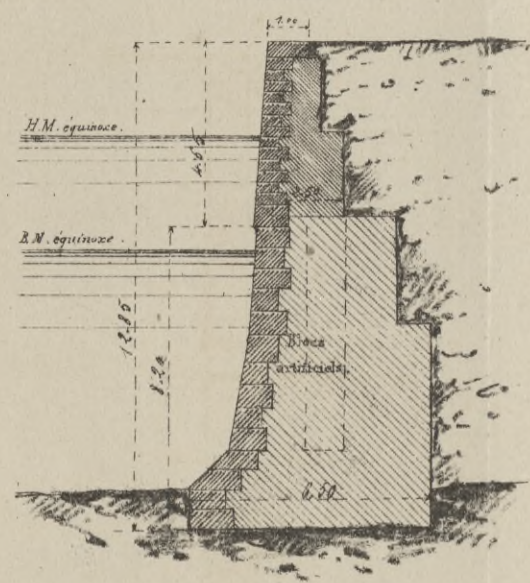
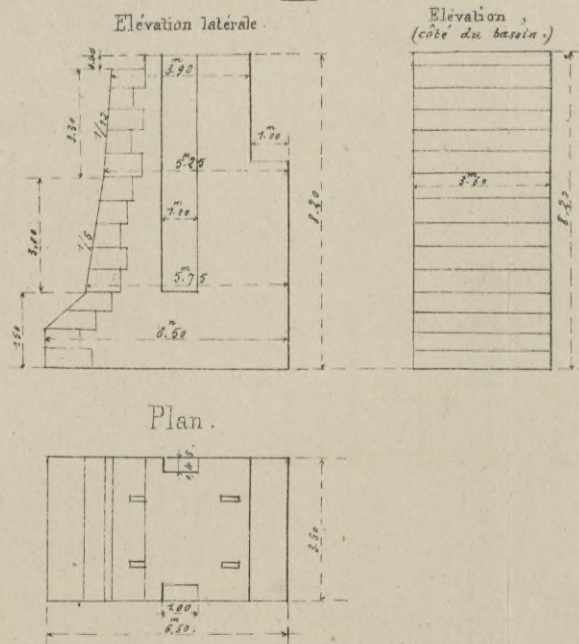

Fig. 152. Blocs artificiels des quais de Dublin.



Levage des blocs pour les quais de Dublin.

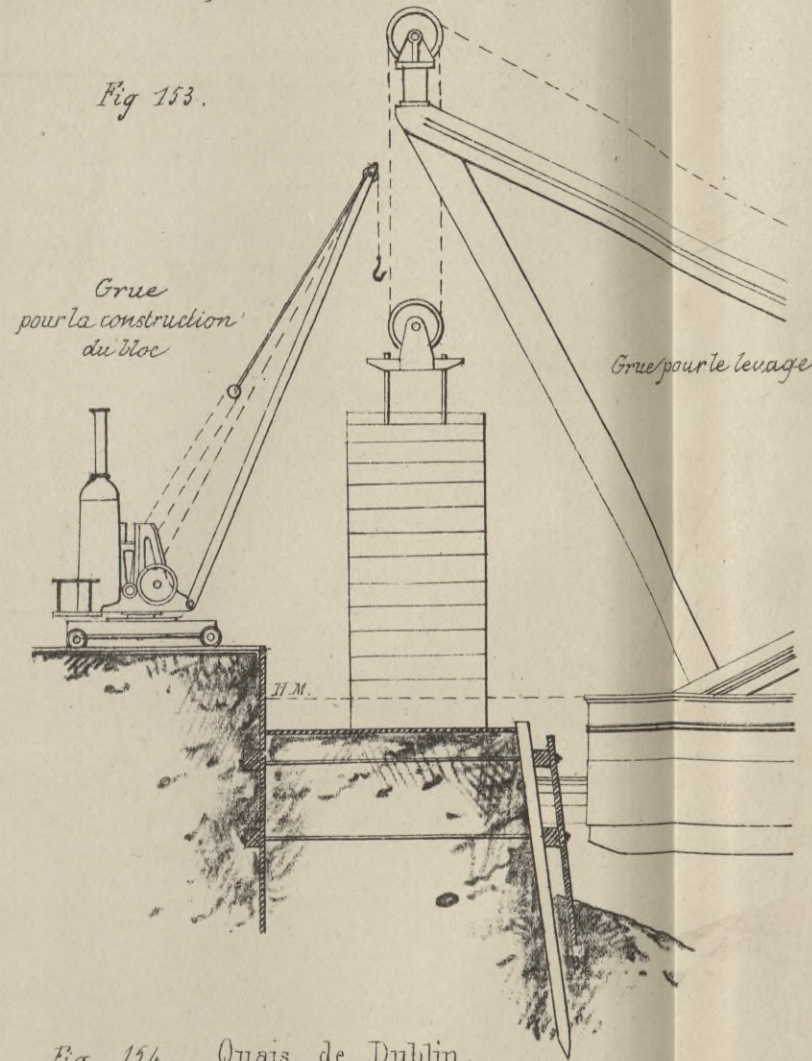

Fig. 154. Quais de Dublin. Coupe horizontale du massif de fondation.

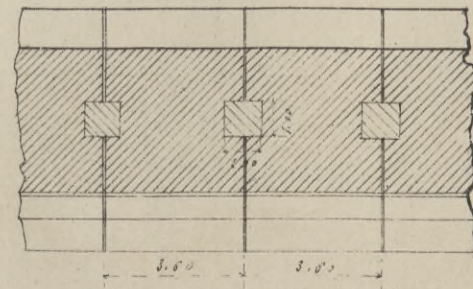

Fig. 155.

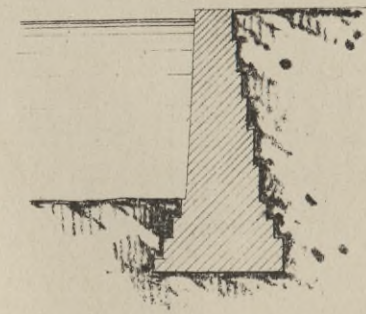

Fig. 156. Mur Anglais.

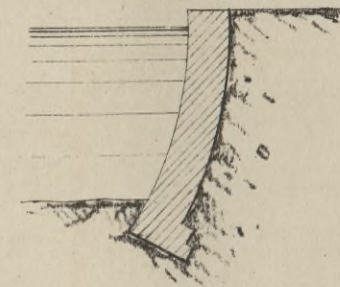
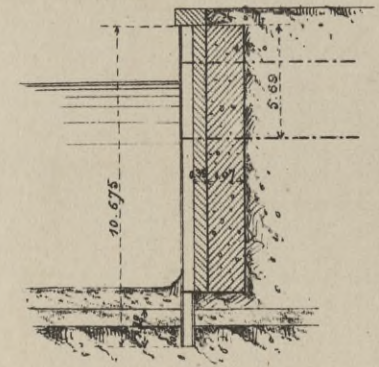

Fig. 158. Quais des Docks-Victoria.



Section horizontale.

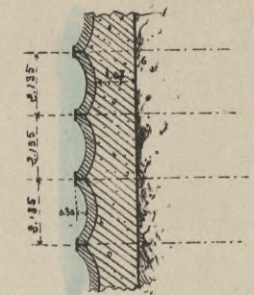

Fig. 157. Quais de Greenock.

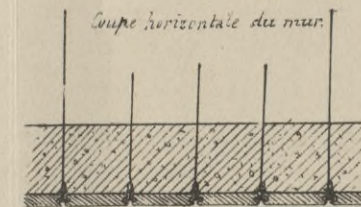
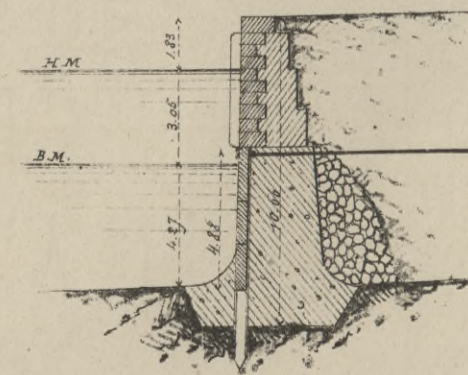
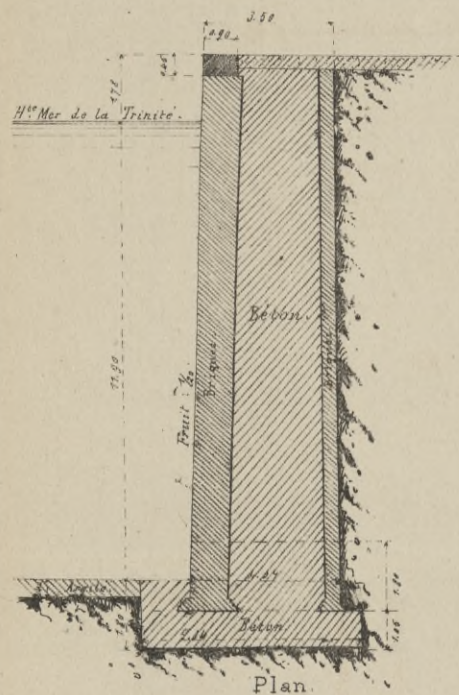





Fig. 159.

Quais du bassin Sud.  
(Docks des Indes occidentales.)



Prix = 990<sup>f</sup> par mètre courant.

Fig. 160.

Blocs du bassin de flot de Bordeaux.

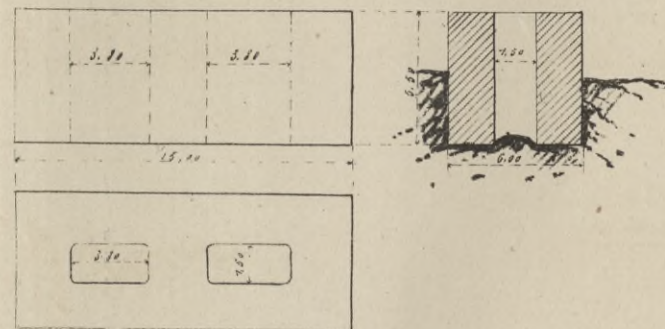

Fig. 161. Quais de Great-Grimby.

Élévation.

Coupe transversale.

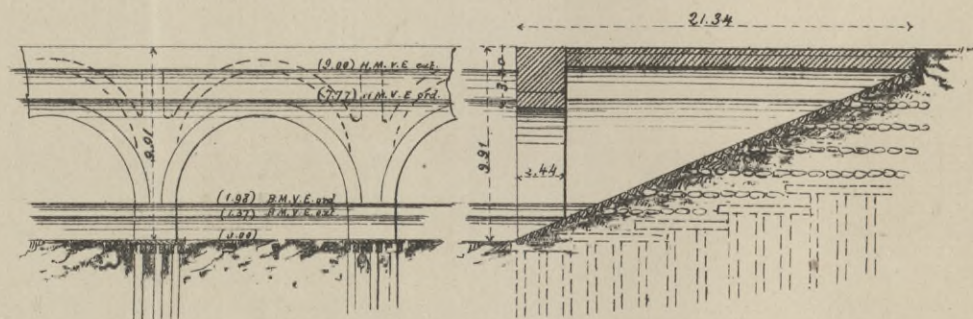

Fig. 162.

Quai en bois, d'Anvers.

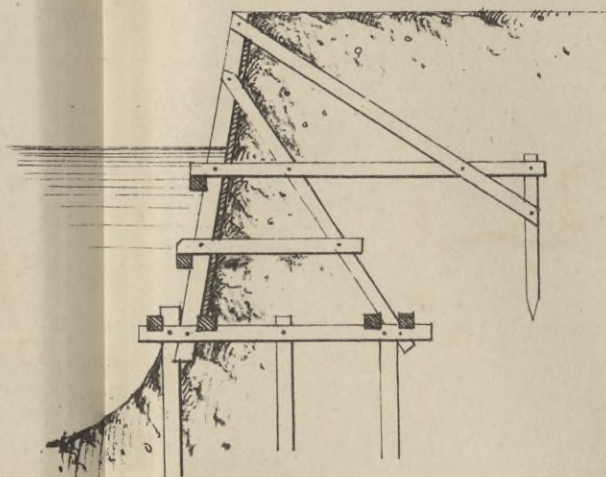

Fig. 163. Quai du Sandthorhafen à Hambourg.

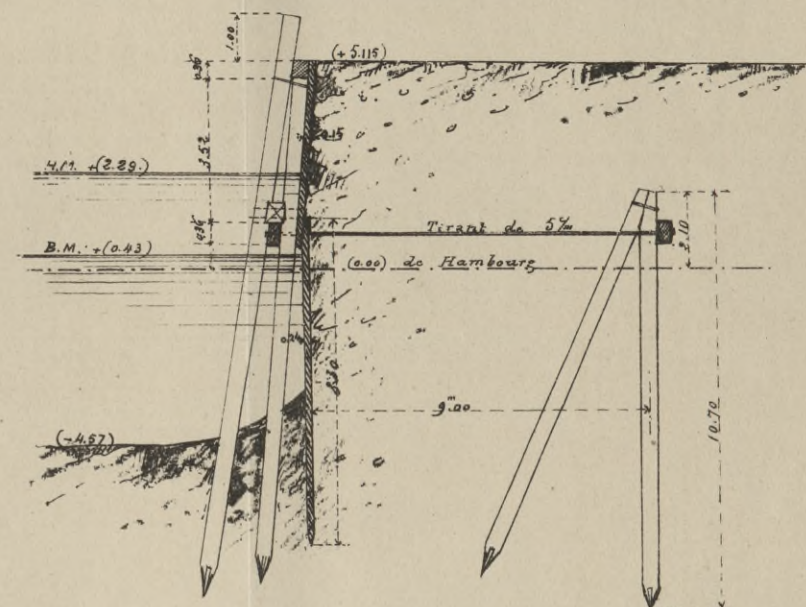
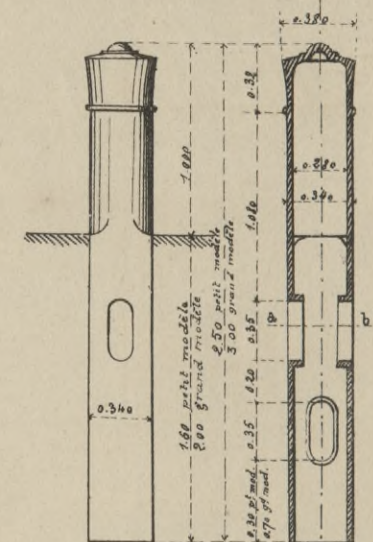
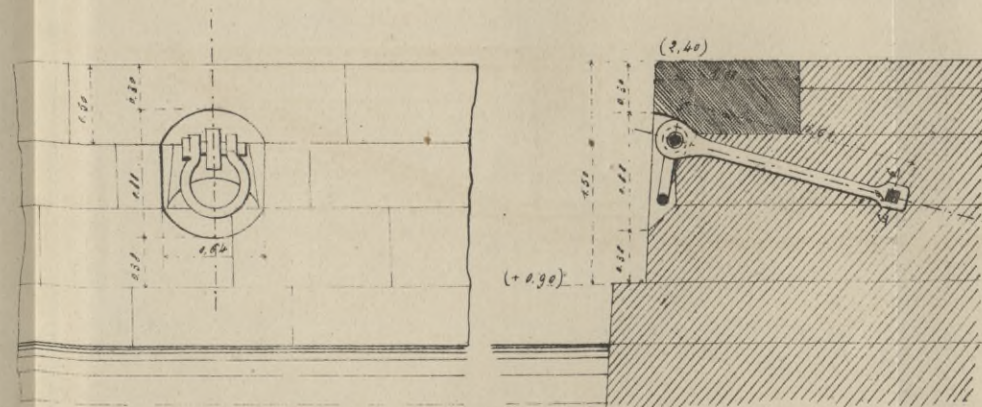

Fig. 165.

Borne d'amarrage.

Fig. 164.



Plan.

Coupe ab.









Fig. 166.  
Quai flottant de Liverpool

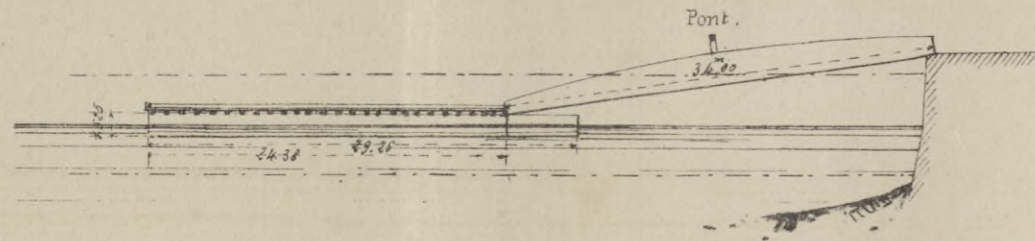

Fig. 168. Appontement de Woolwich.

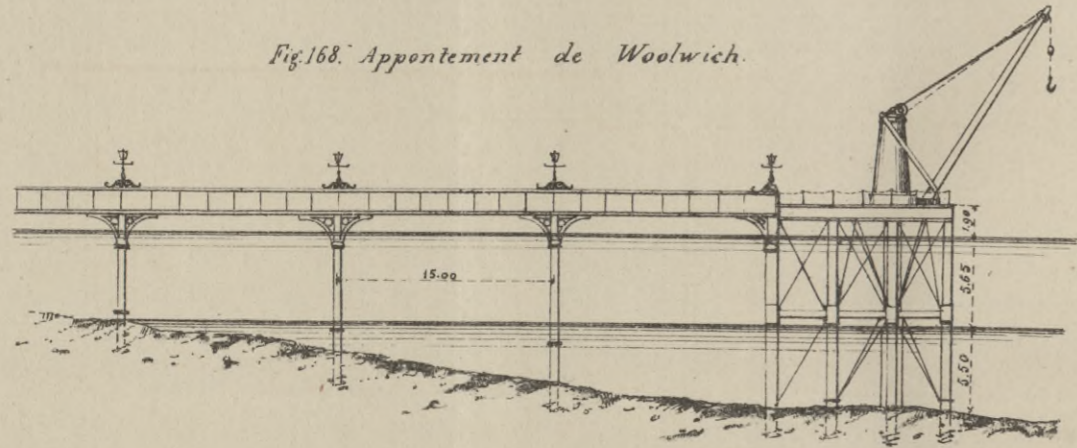

Fig. 169

Coupe transversale de l'appontement de Woolwich

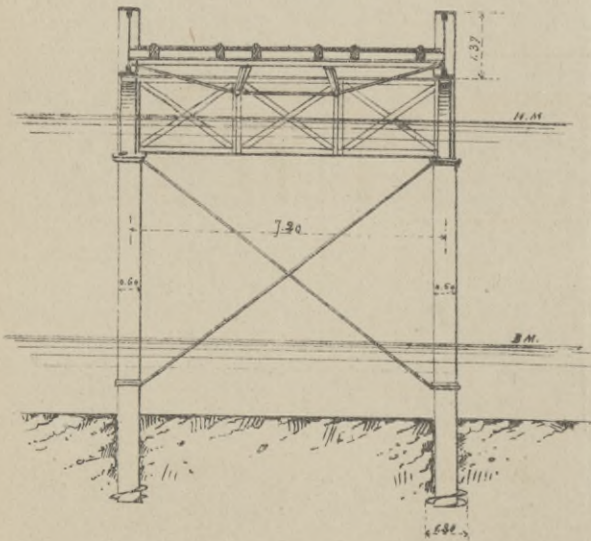

Fig. 170. Pont à bascule.

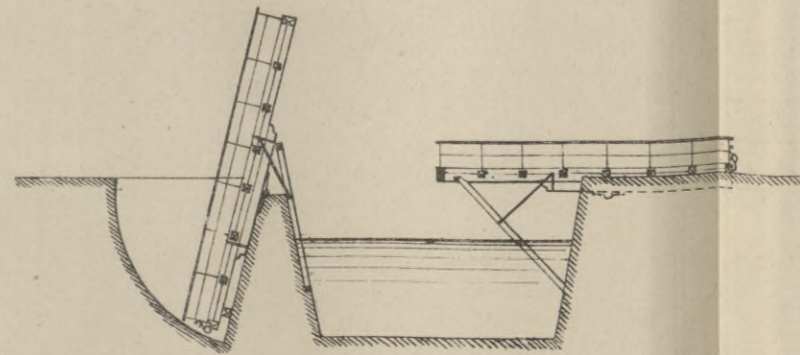
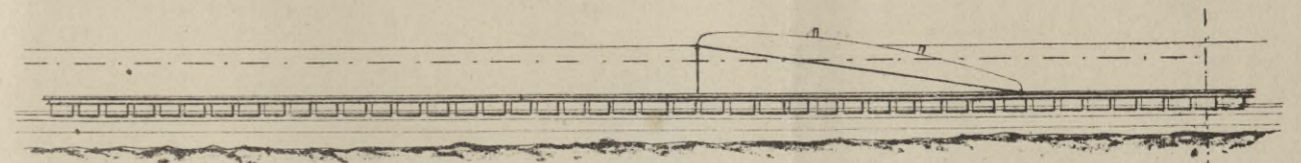

Fig. 167.  
Quai flottant de Birkenhead.

Elevation.



Plan.

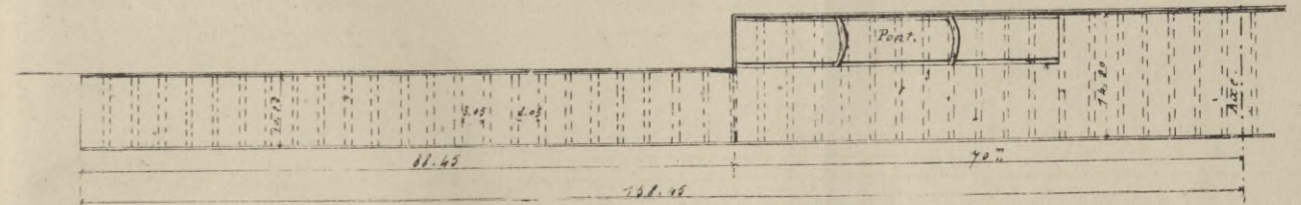
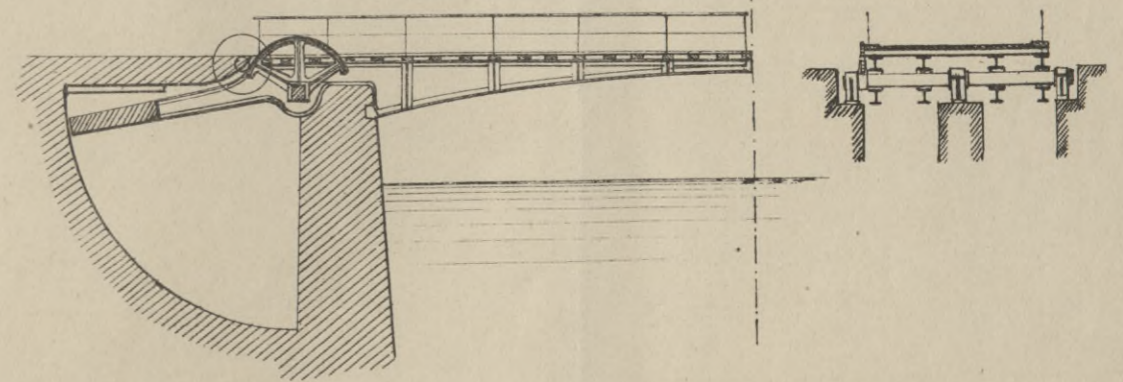

Fig. 171. Pont à bascule du Commercial-dock.  
(Londres.)





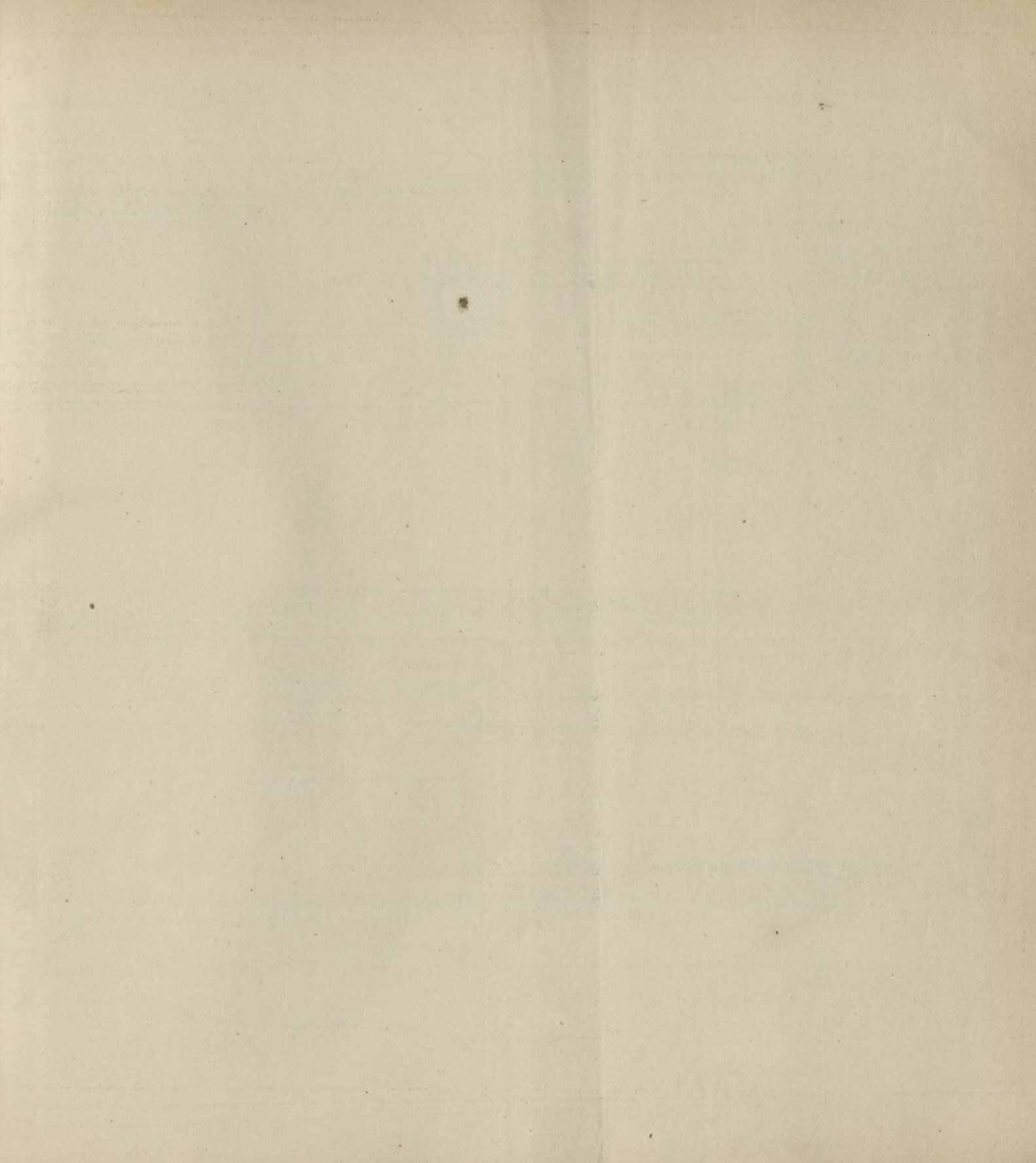

Fig. 172. Pont à bascule.  
(Système Lamblardie)

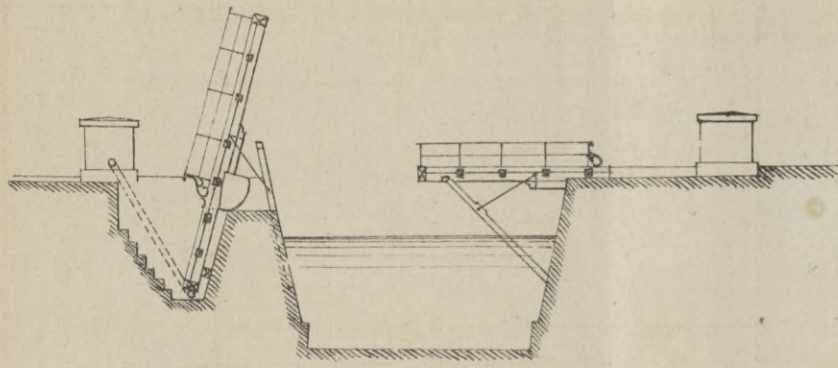
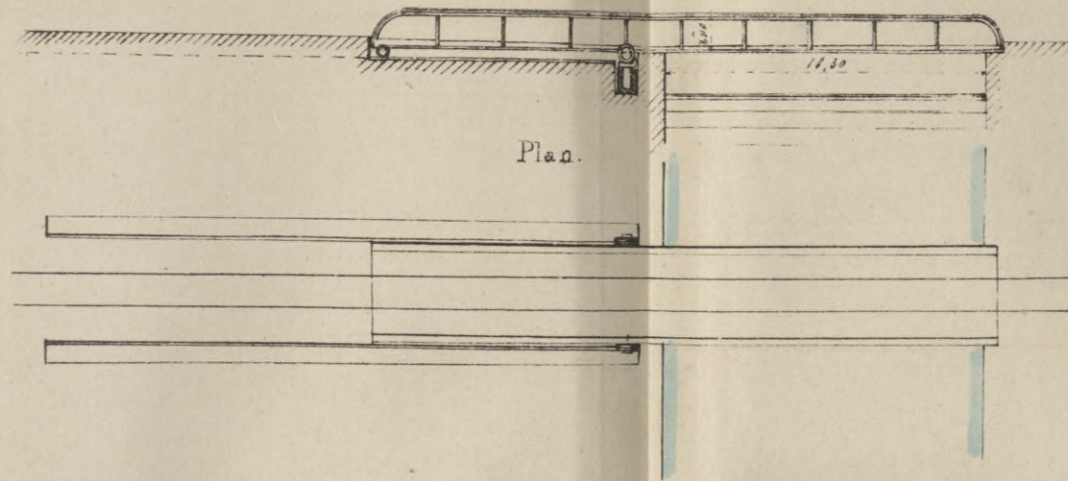

Fig. 174. Pont roulant de Sunderland.

Elevation.



Plan.

Fig. 175. Pont roulant, système Gibson.

Elevation

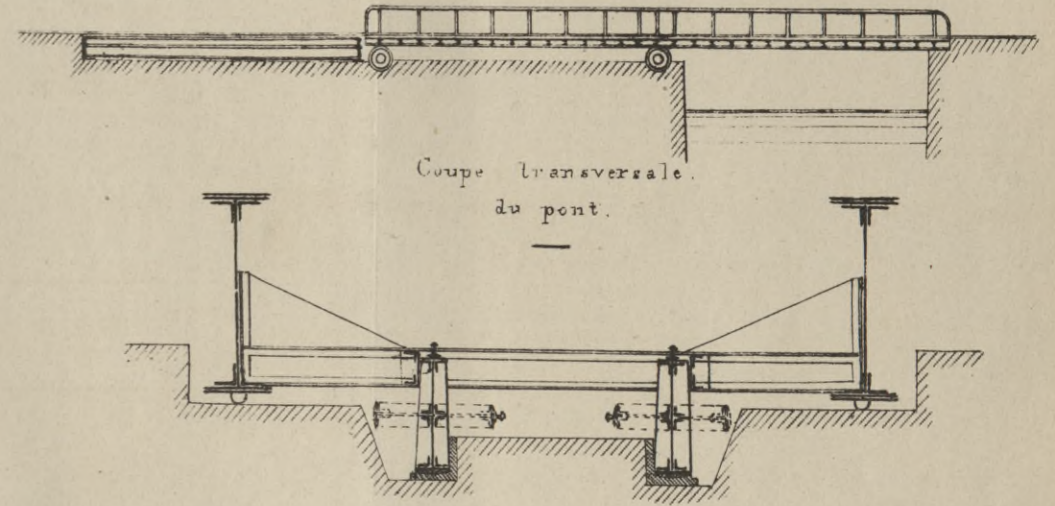

Coupe transversale  
du pont.

Fig. 173. Pont roulant de Southampton.

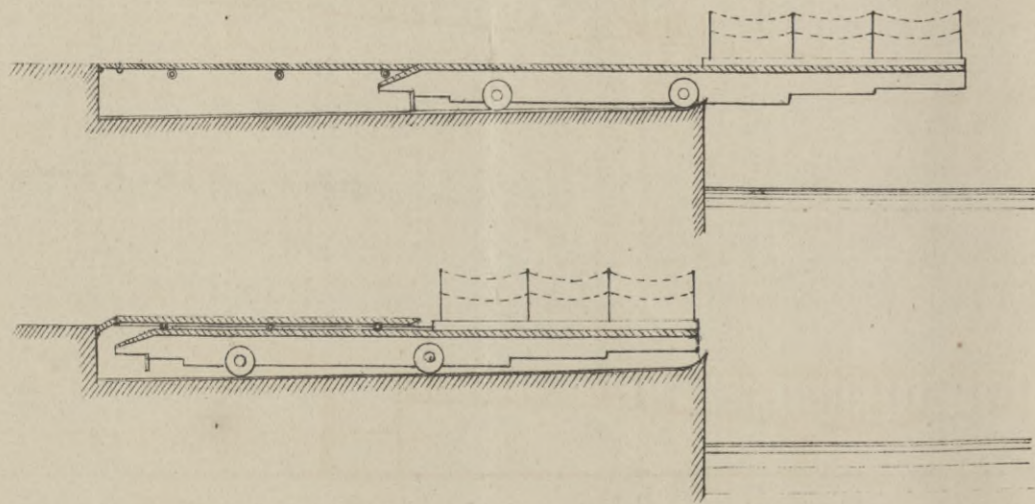

Fig. 176. Pont tournant du Havre.

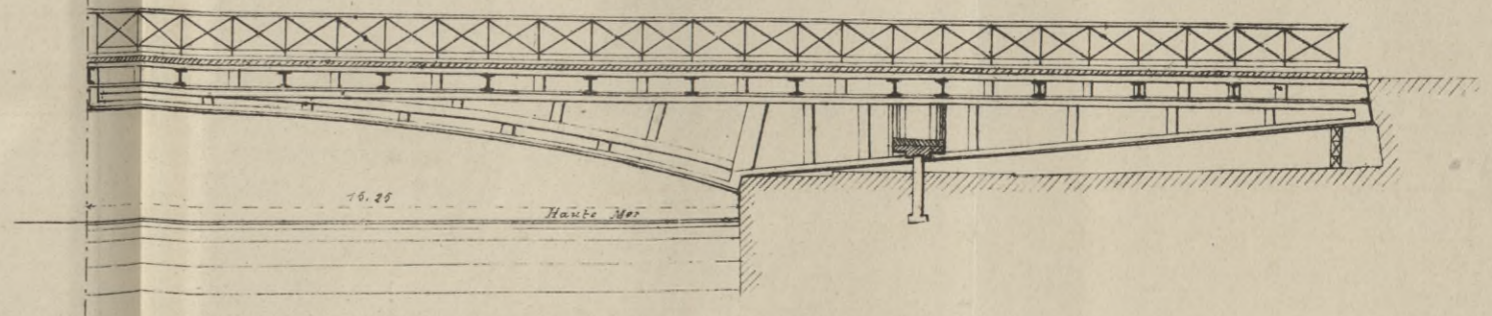
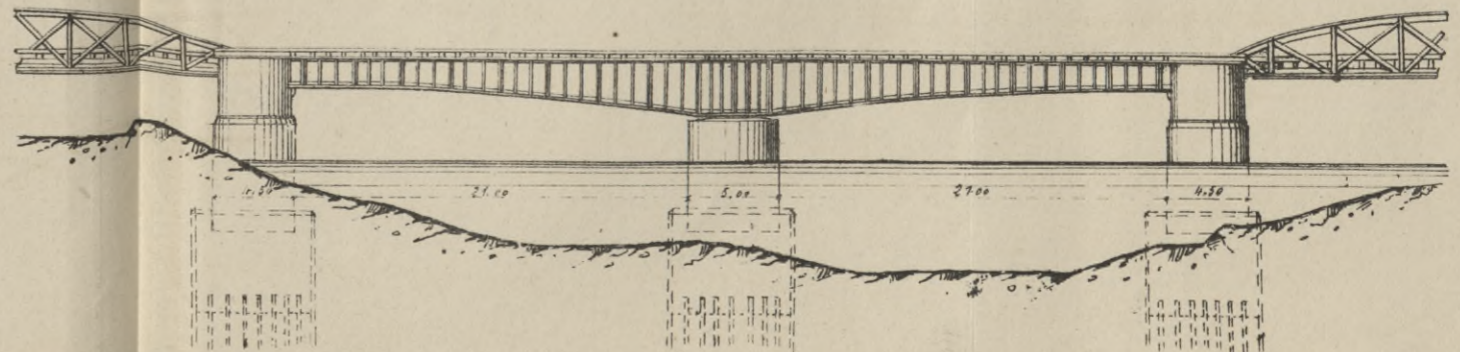

Fig. 177. Pont-tournant d'Amsterdam.



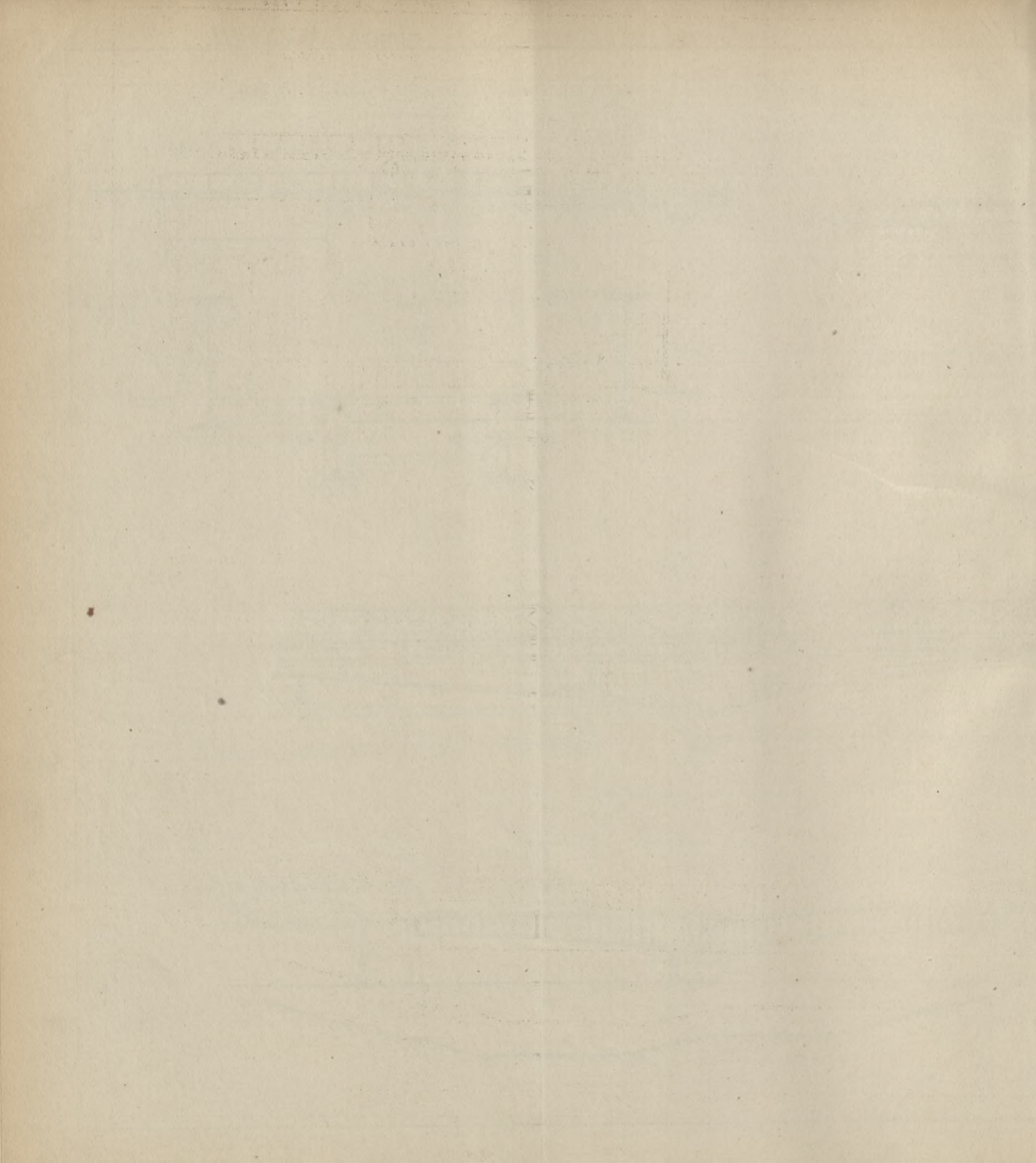



Fig. 178. Pont tournant de Dordrecht.

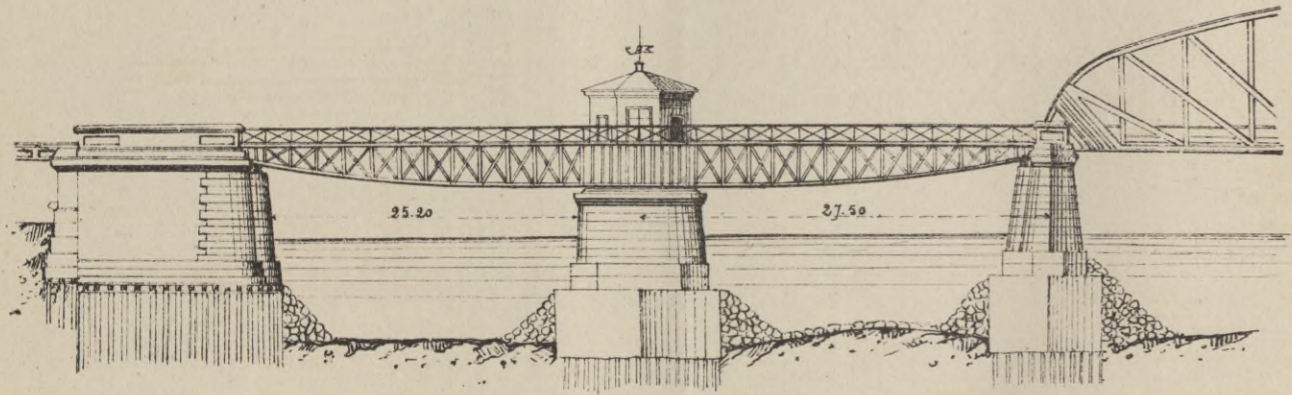
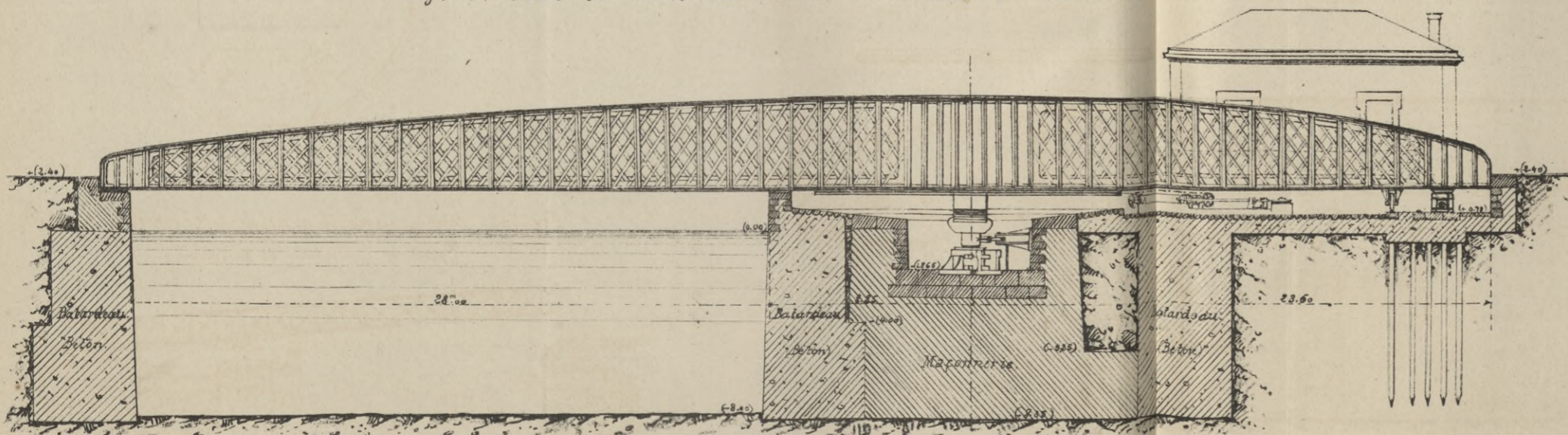
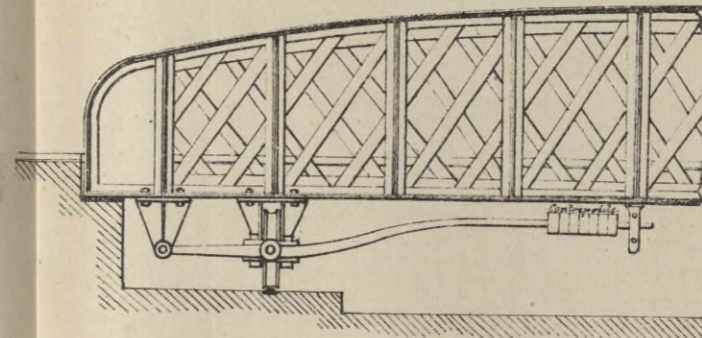

Fig. 179. Pont tournant des bassins de radoub de Marseille.



Echelle de 0.004 par mètre.

Fig. 180. Roues de culasse actionnées par des contrepoids.



Plan.

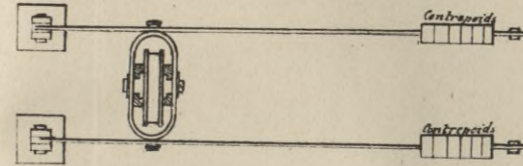
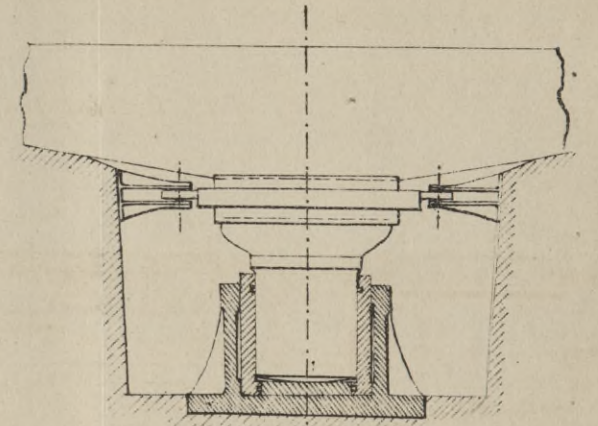

Fig. 181.



Plan.

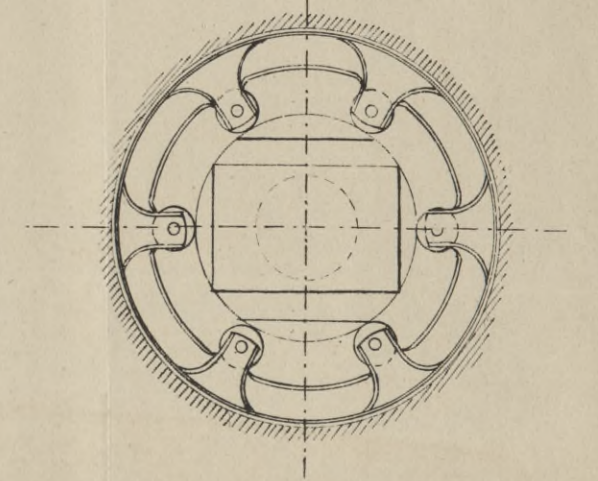
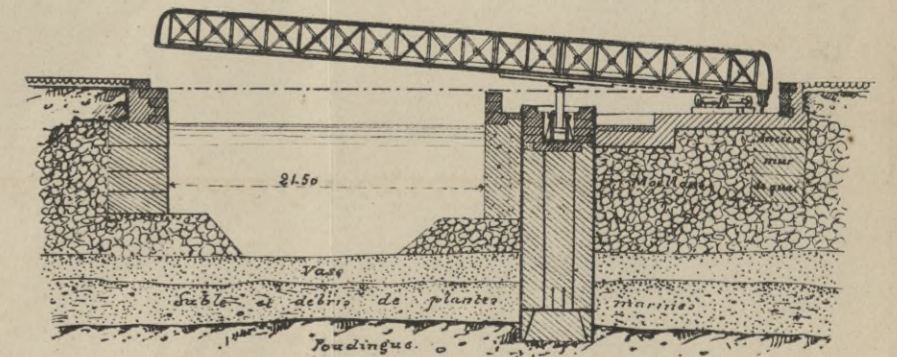

Fig. 182. Pont tournant en fer de la traverse de la Jolie.  
(pendant l'opération de basculement.)









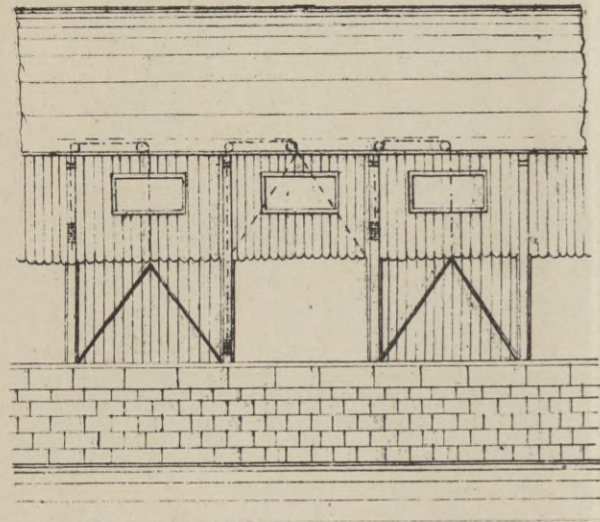

Fig. 183.

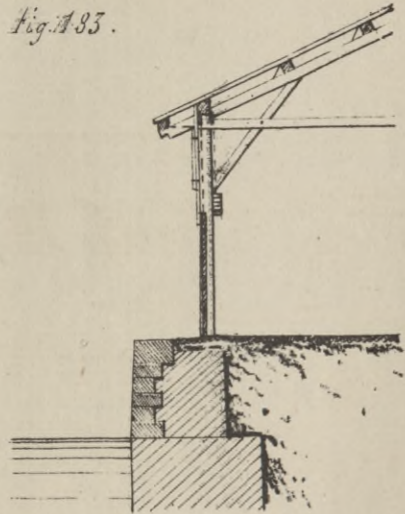

Fig. 184.

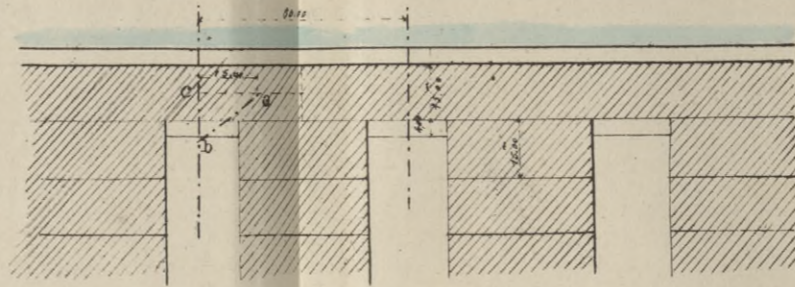

Fig. 185.

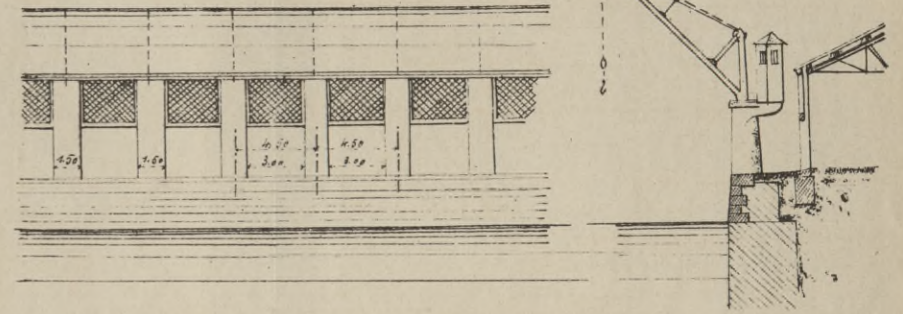

Fig. 186.

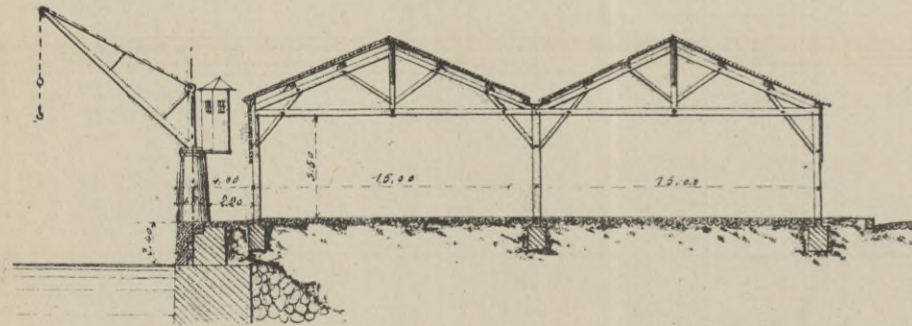

Fig. 187.

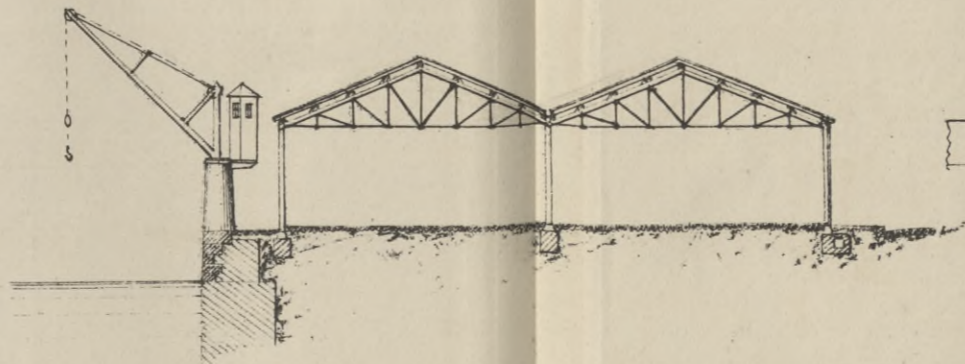
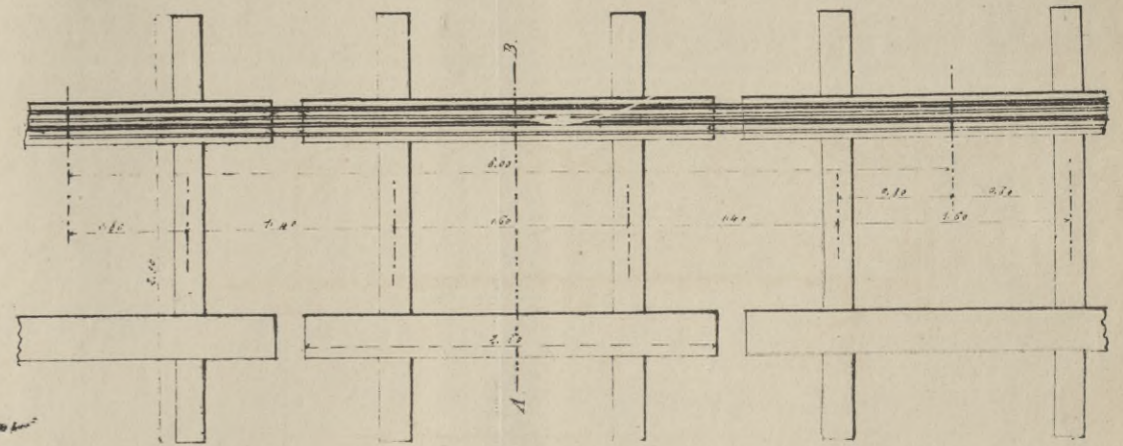

Fig. 188.



Coupe AB

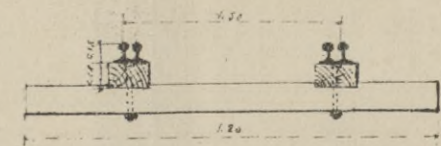





Fig. 189.

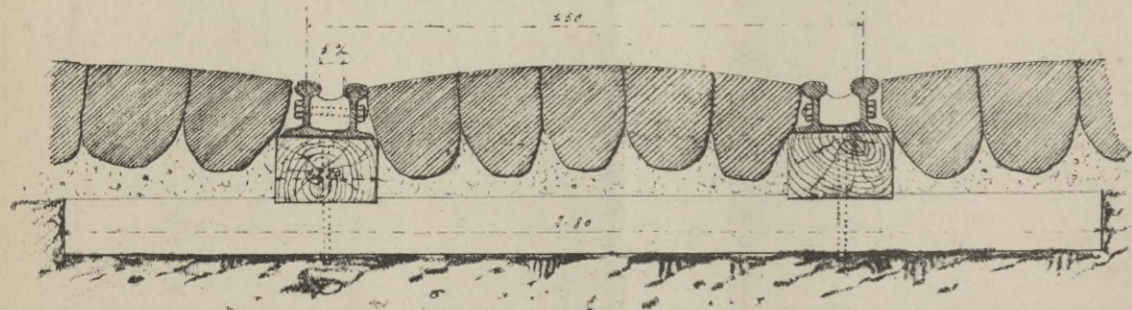

Fig. 190. Plaque tournante.

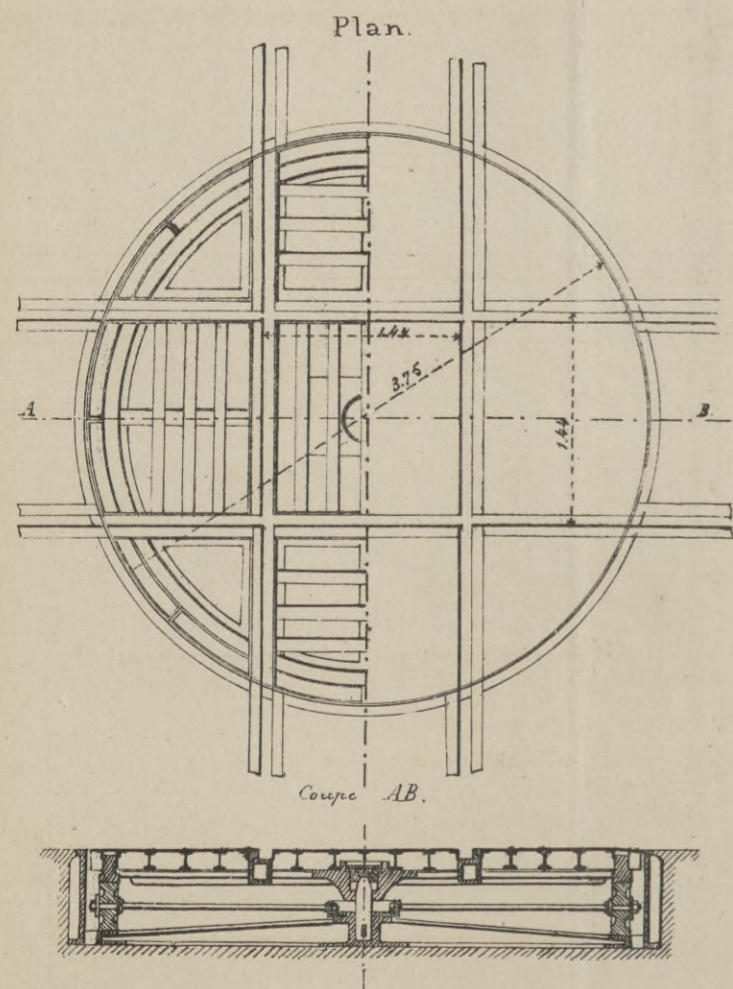

Fig. 191.

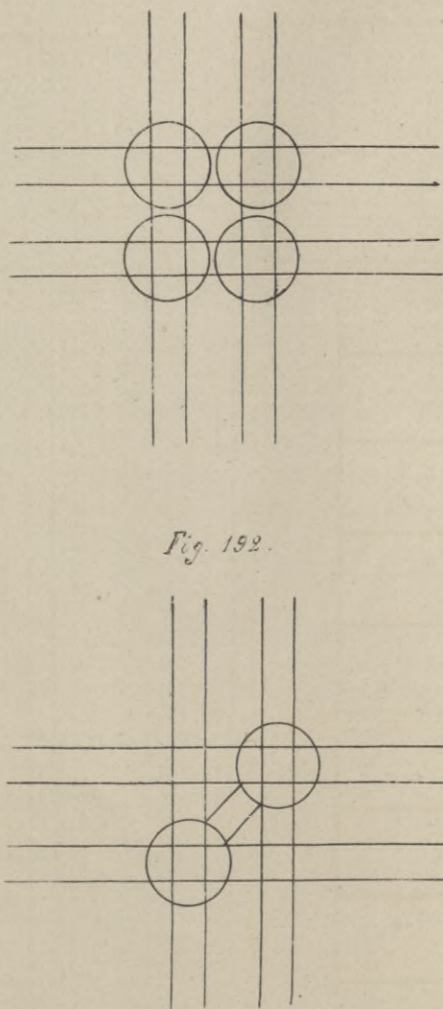

Fig. 192.

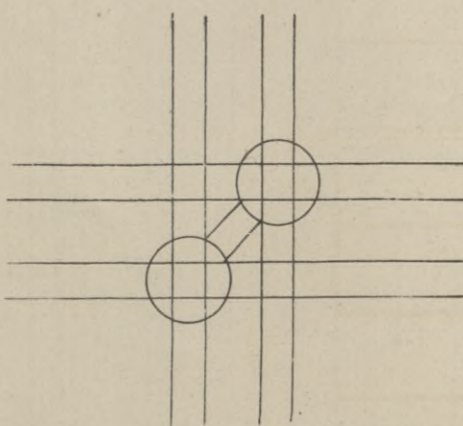
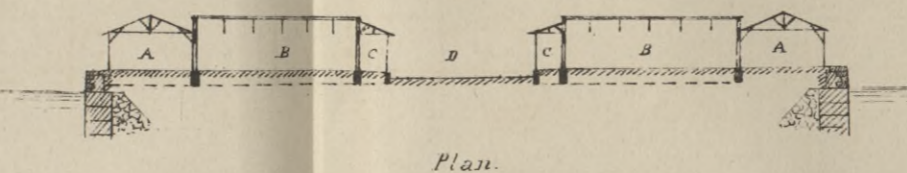

Fig. 193.



Fig. 194.



Plan.

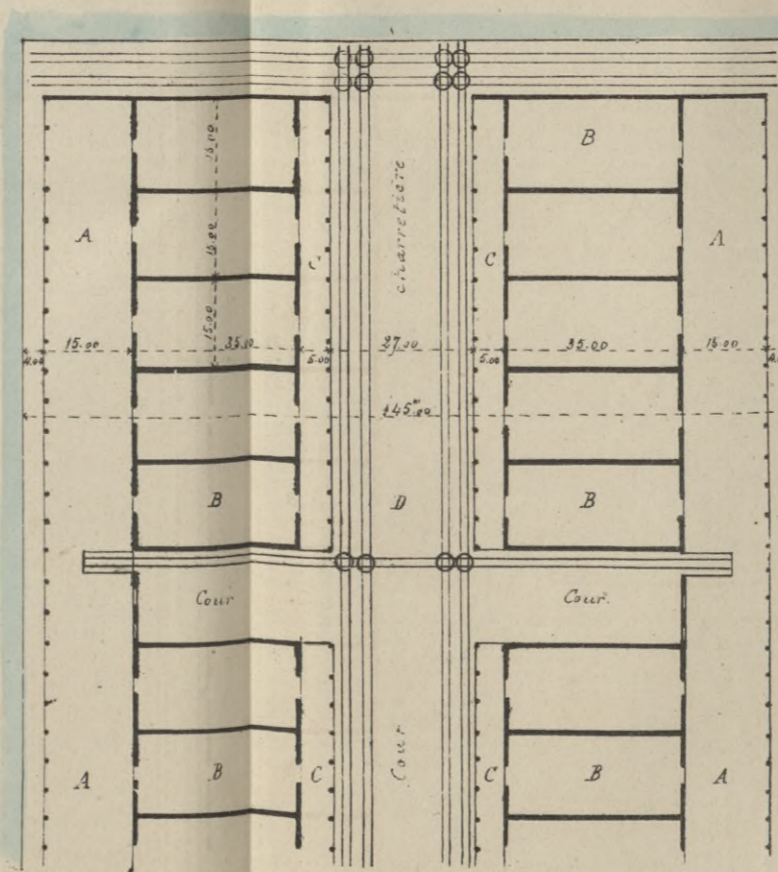
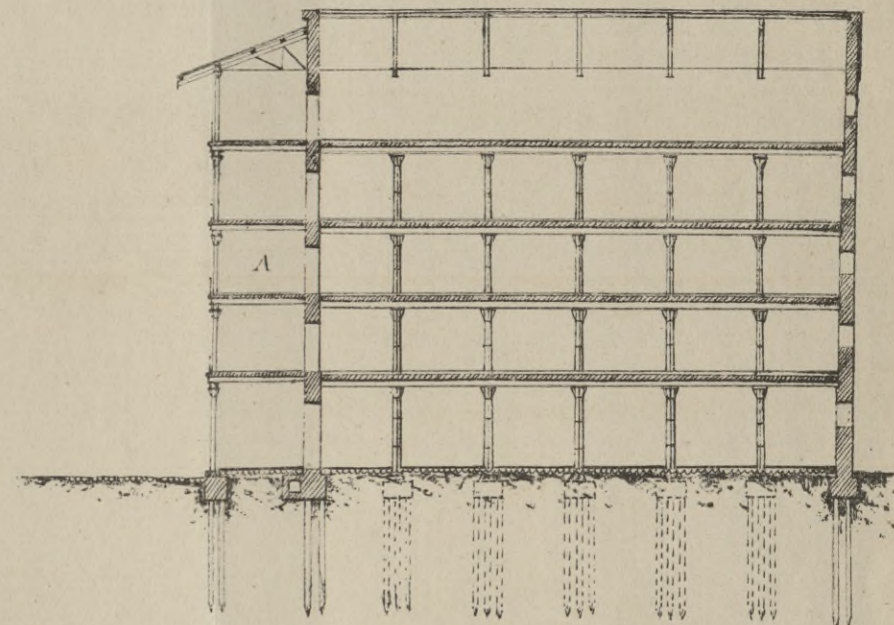

Fig. 195. Entrepôts.



Plan.

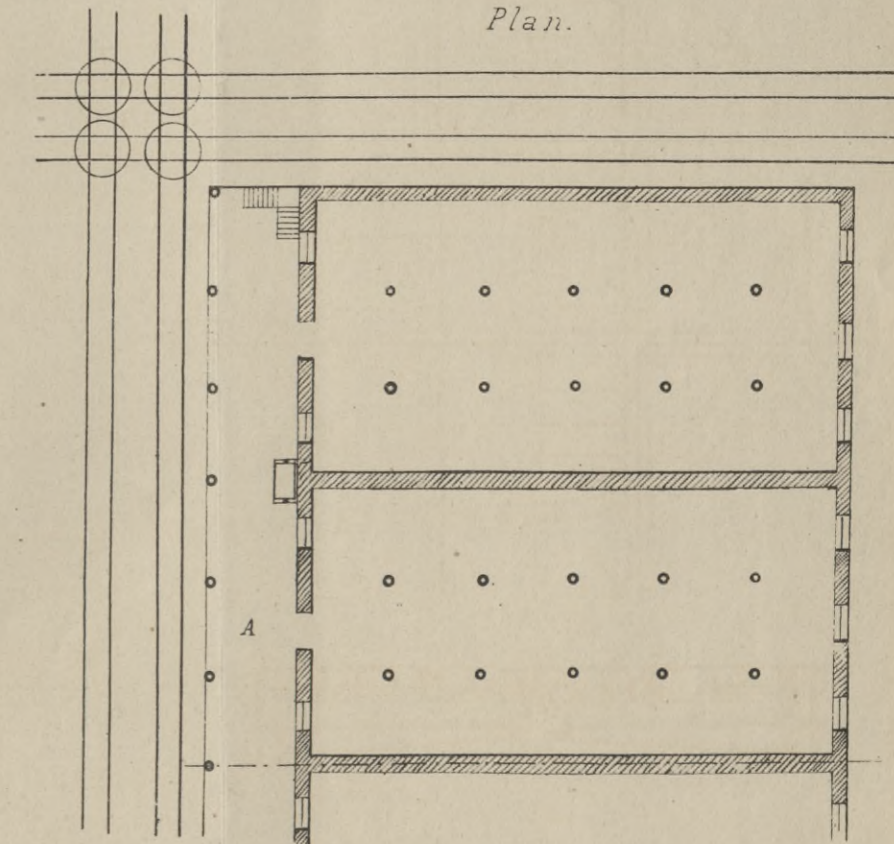







Fig. 196.

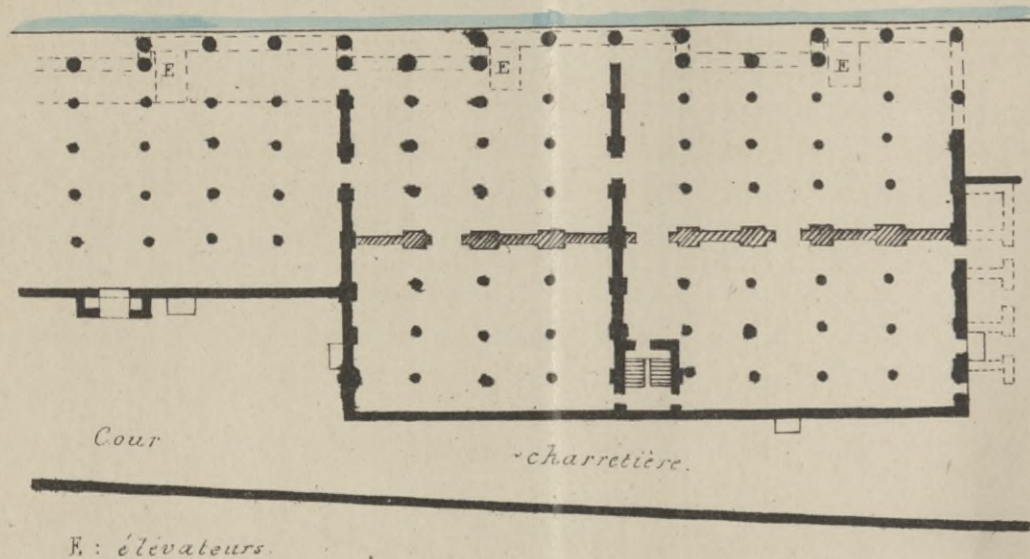
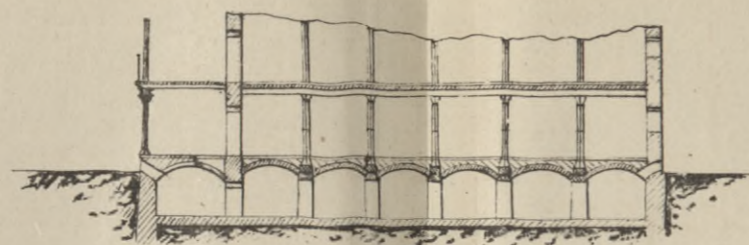

Fig. 198.



Plati

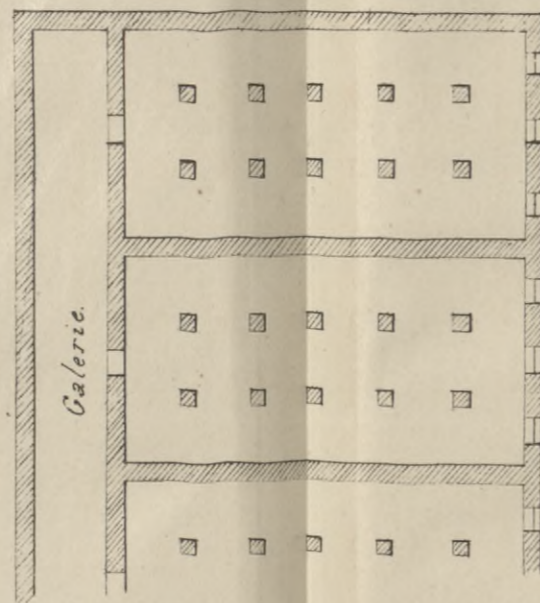
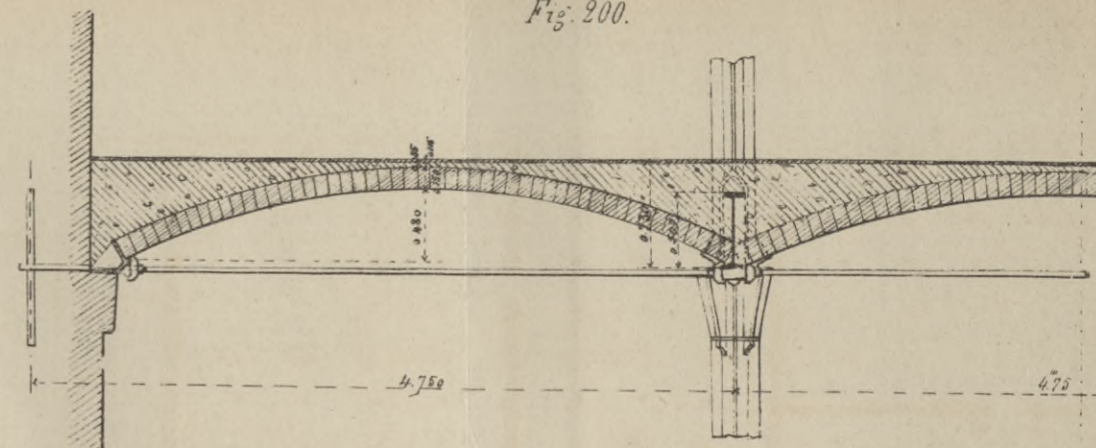

Fig. 200.



Coupe suivant ab

Fig. 201.

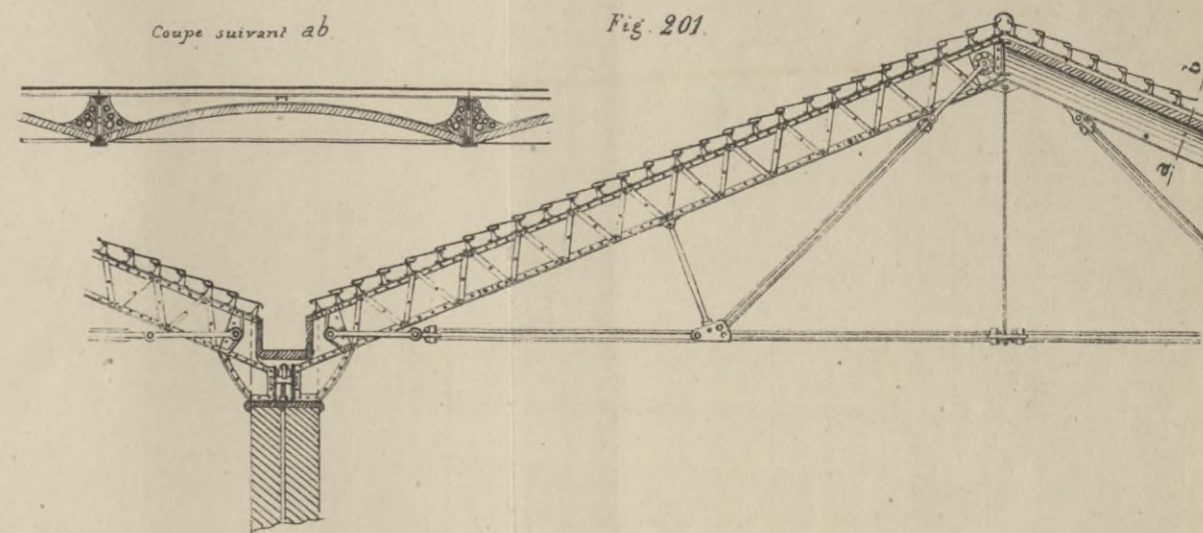

Fig. 197.

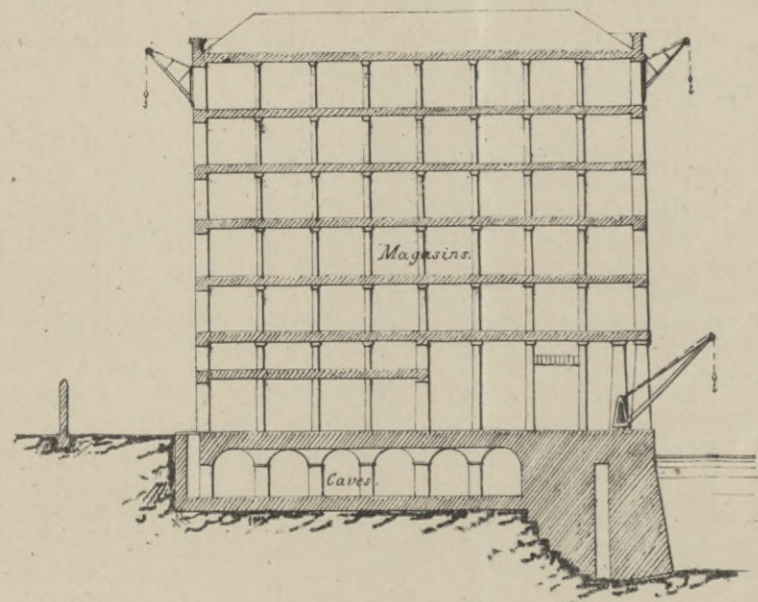

Fig. 199.

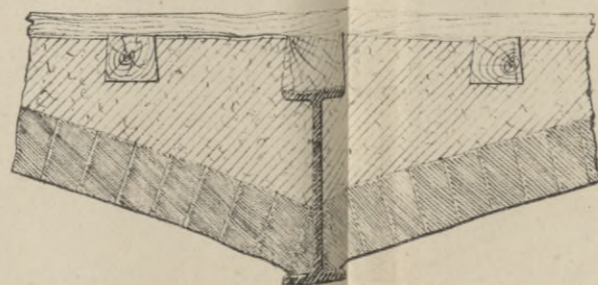
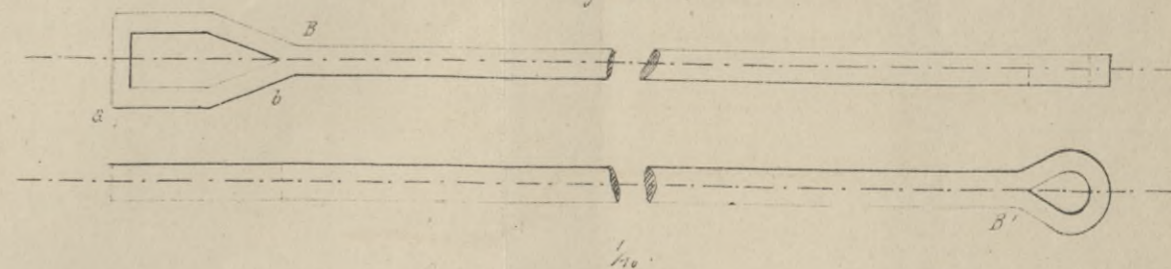
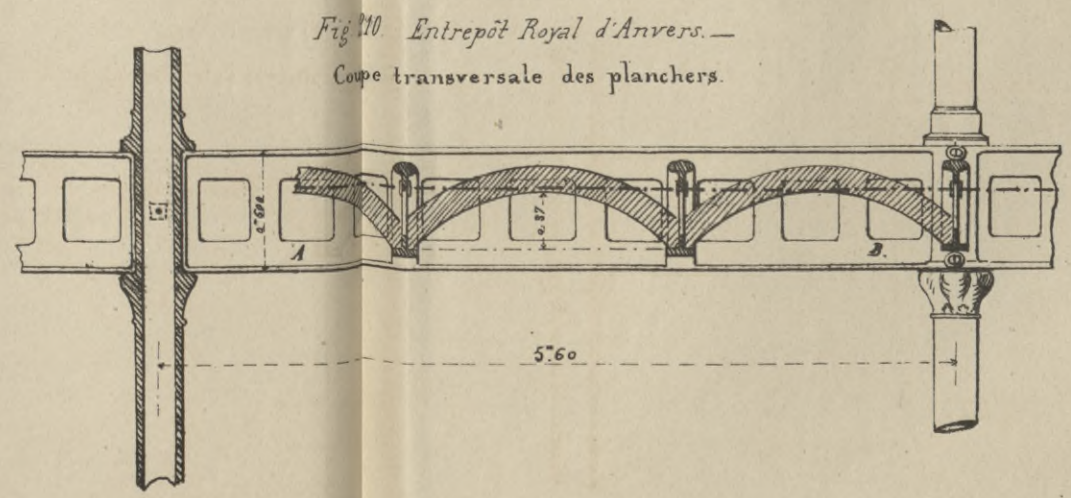
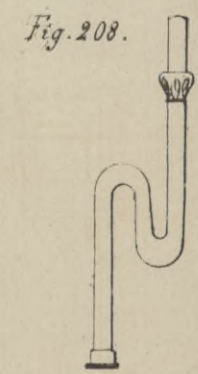
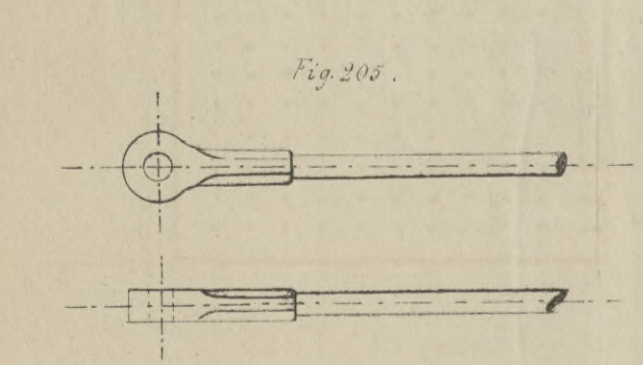
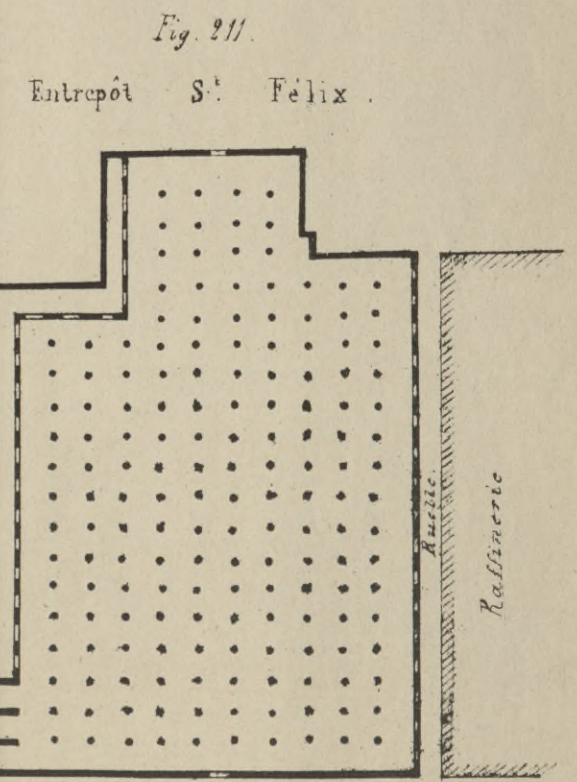
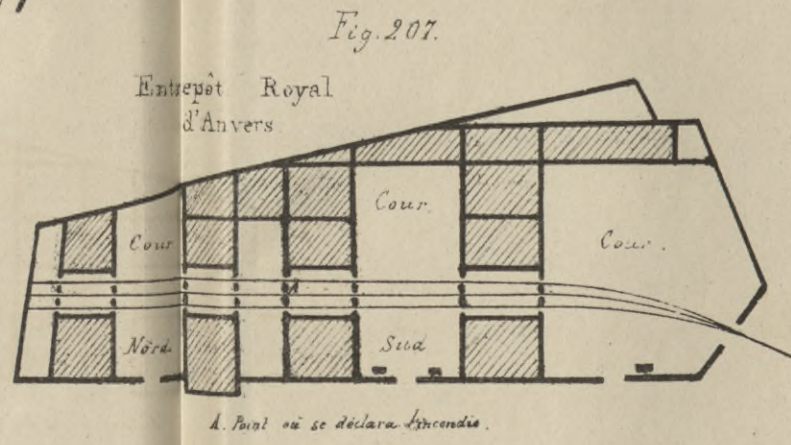
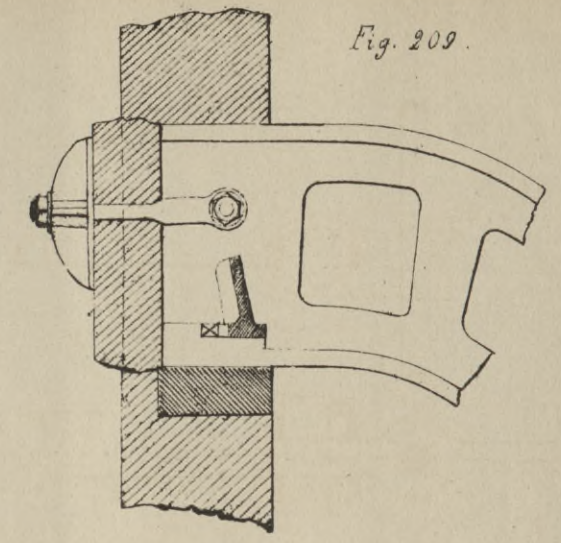
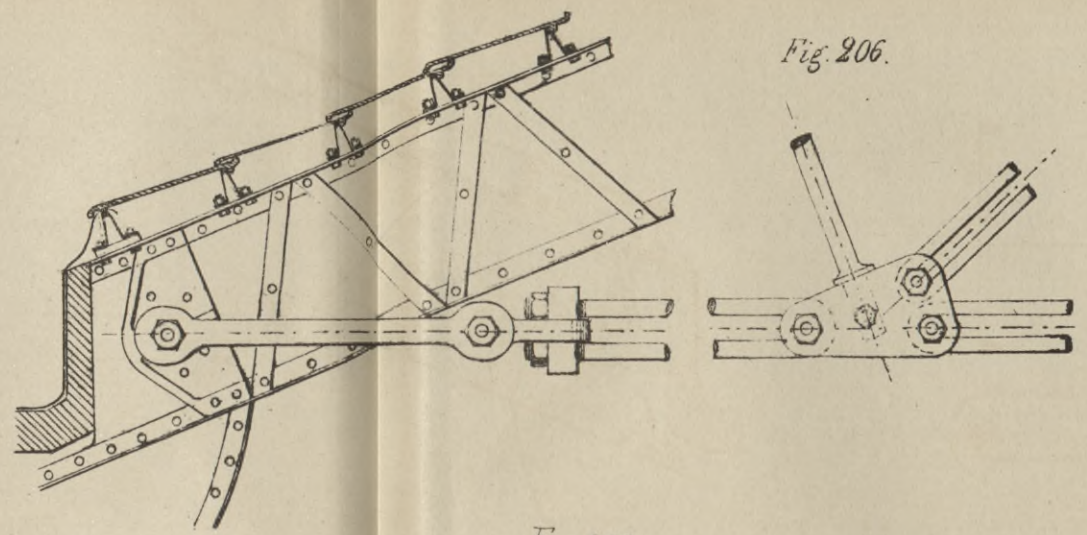
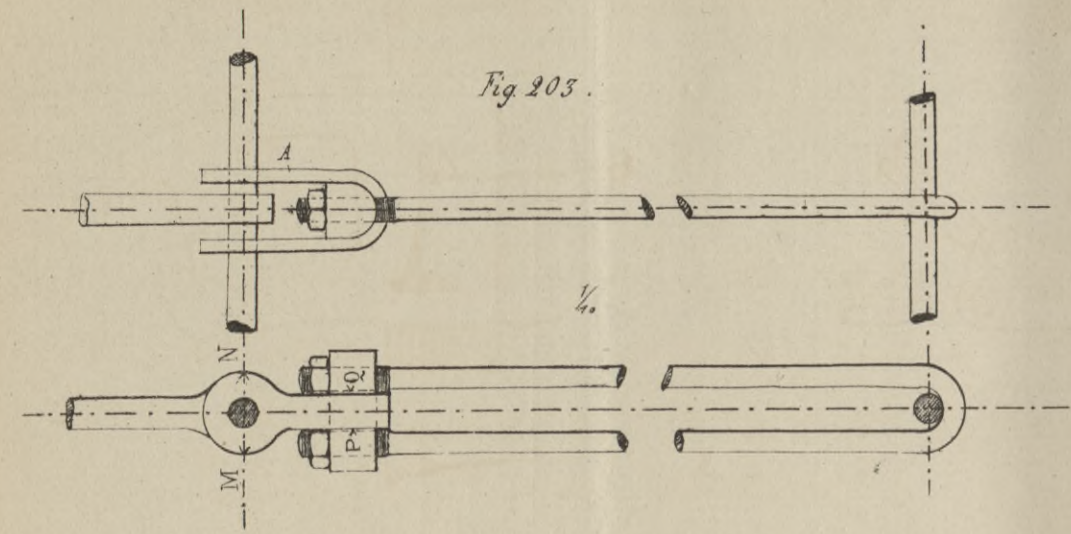

Fig. 202.









Paris.







Fig. 212.

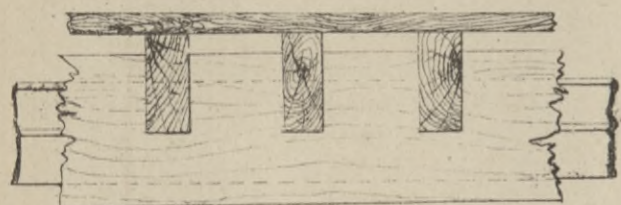

Fig. 213.

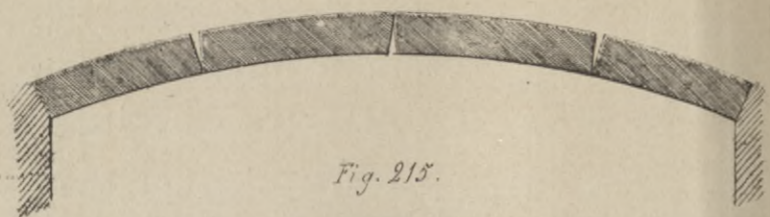
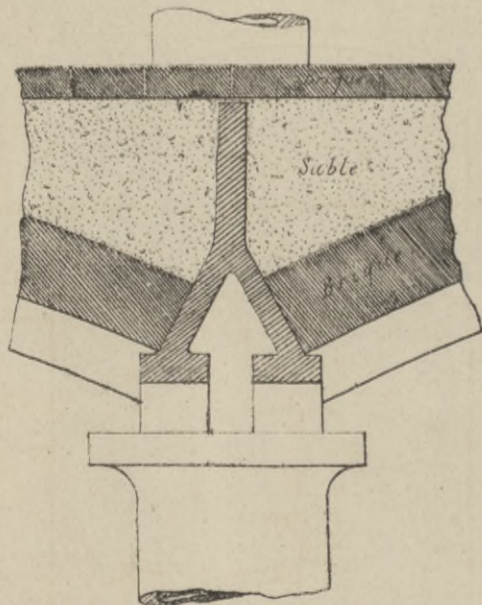

Fig. 214.



Fig. 215.

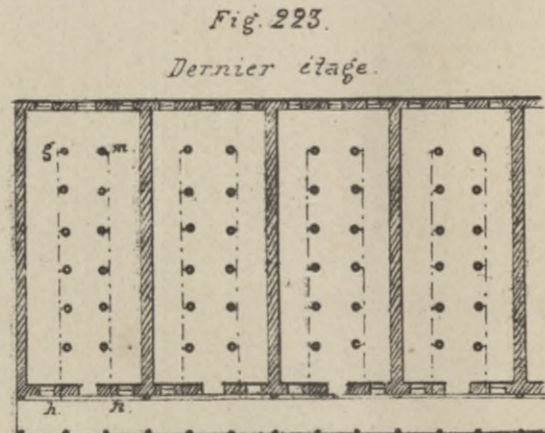

Fig. 223.  
Dernier étage.

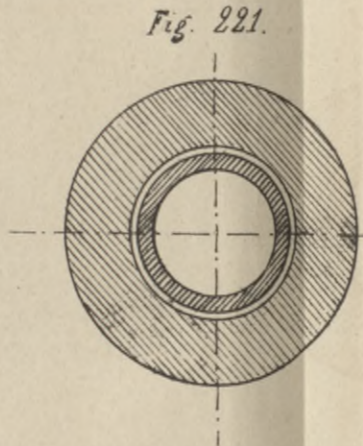

Fig. 221.

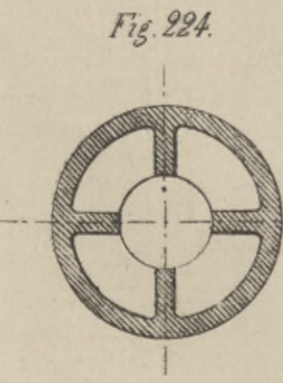

Fig. 224.

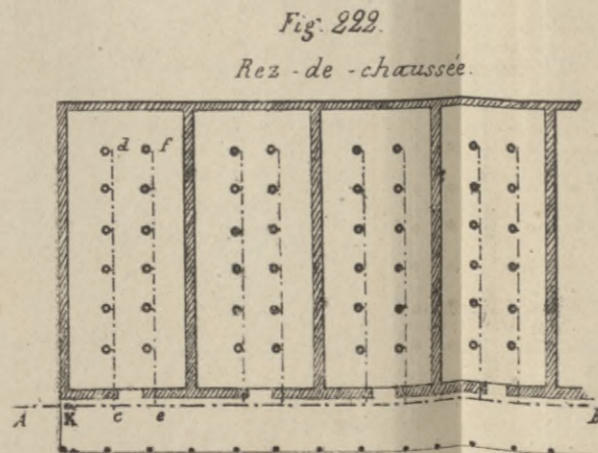

Fig. 222.  
Rez-de-chaussée.

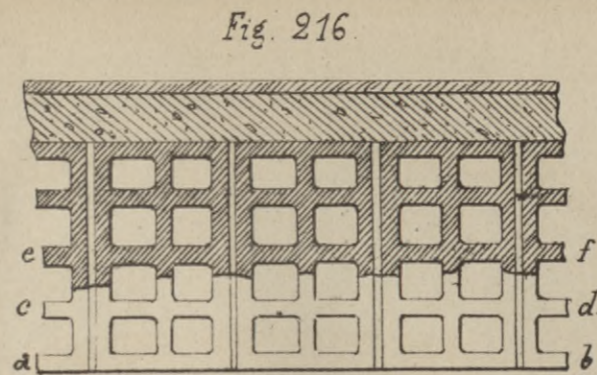

Fig. 216.

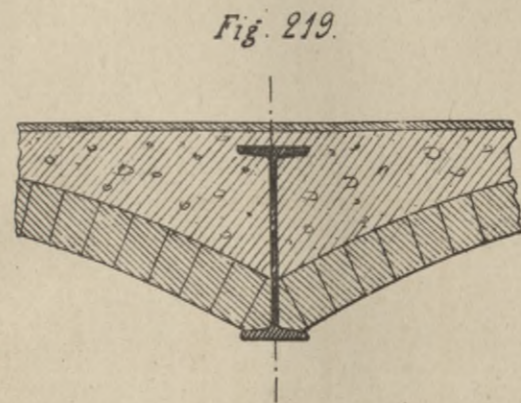

Fig. 219.

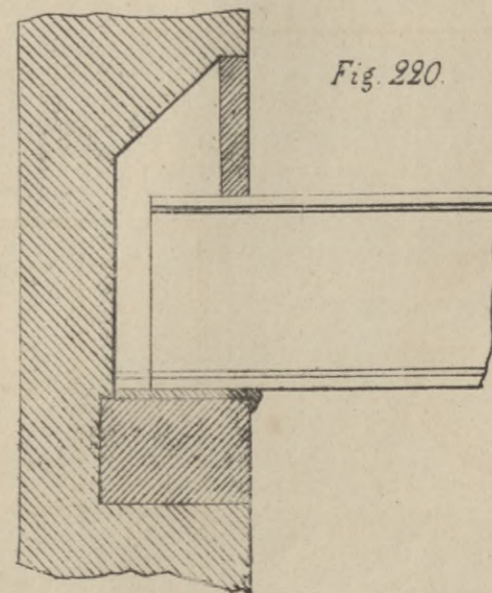

Fig. 220.

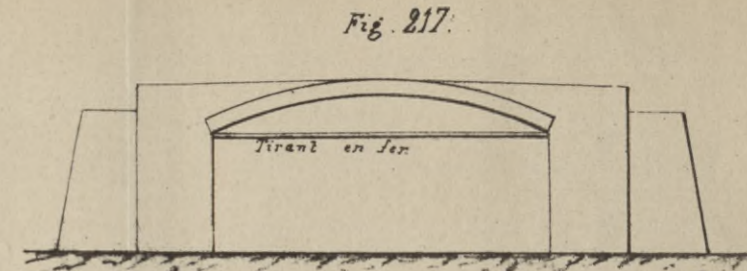

Fig. 217.

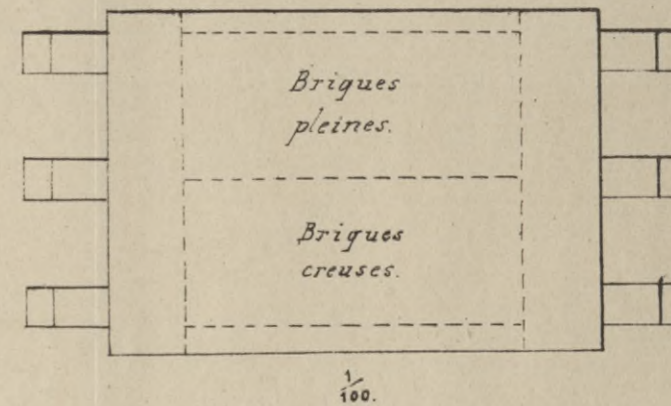

Fig. 218.

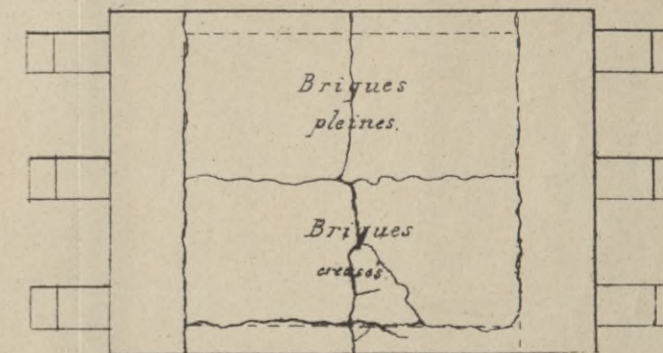
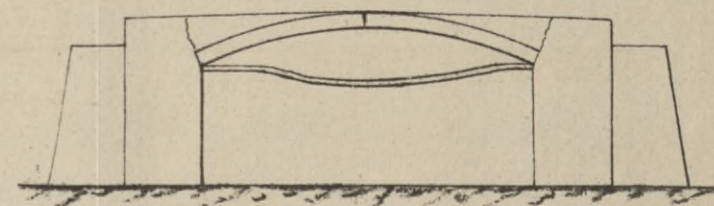







Fig. 225.

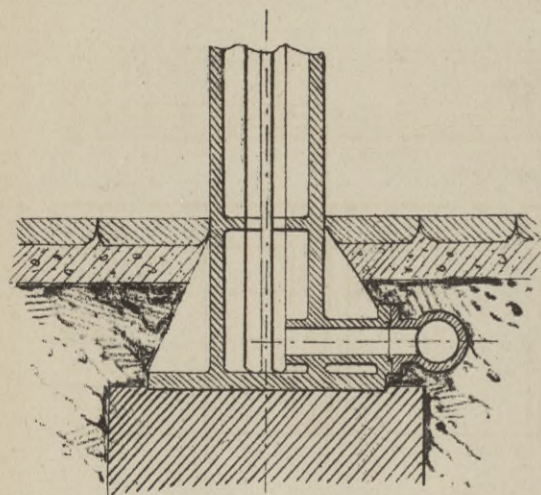

Fig. 226.

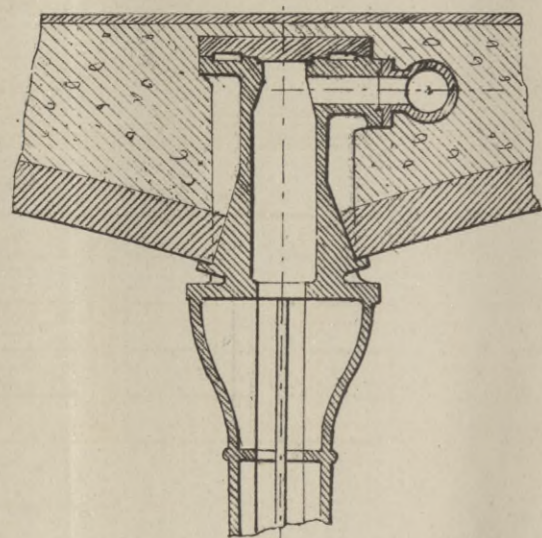

Fig. 227.

Plan du tuyautage soumis aux expériences.

Longueur 1354<sup>m</sup>

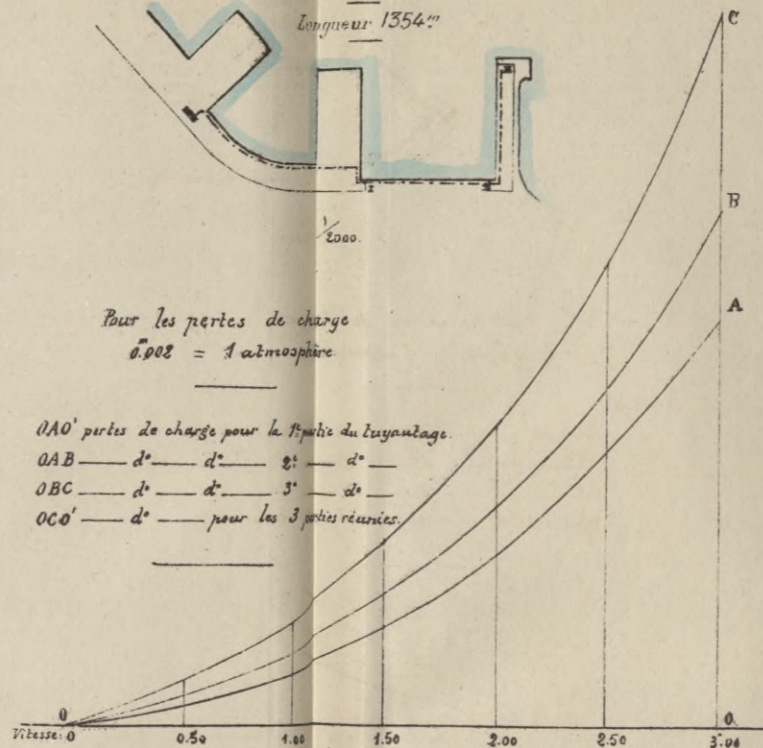
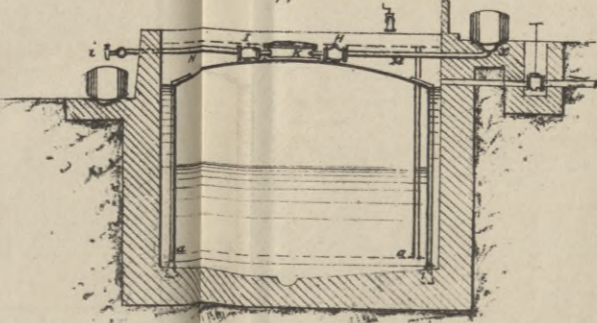

Fig. 231. Appareil Chiardi.



Plan.

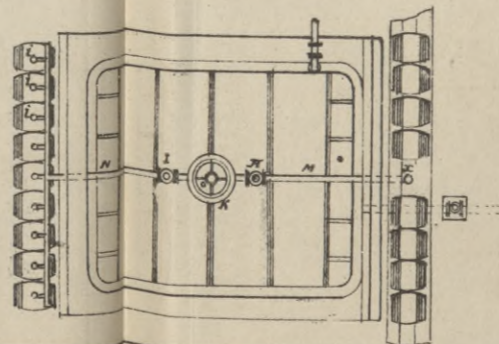
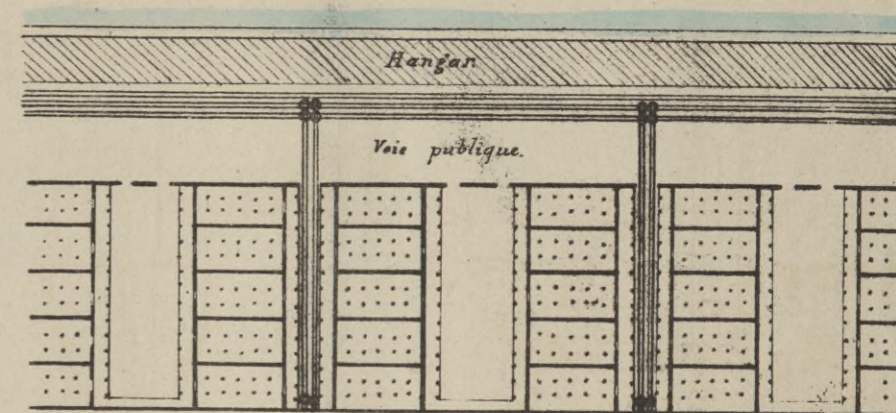

Fig. 228. Magasins pour les vins.

Plan général.



Disposition des magasins.

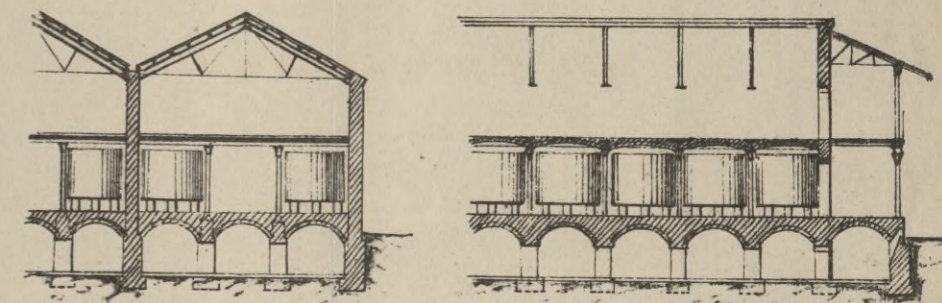
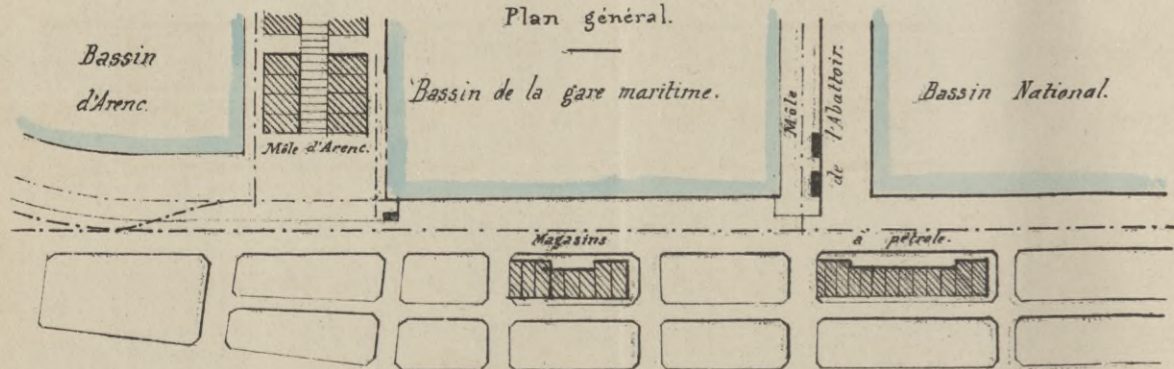

Fig. 230. Magasins à pétrole de Marseille.

Plan général.



Disposition des magasins.

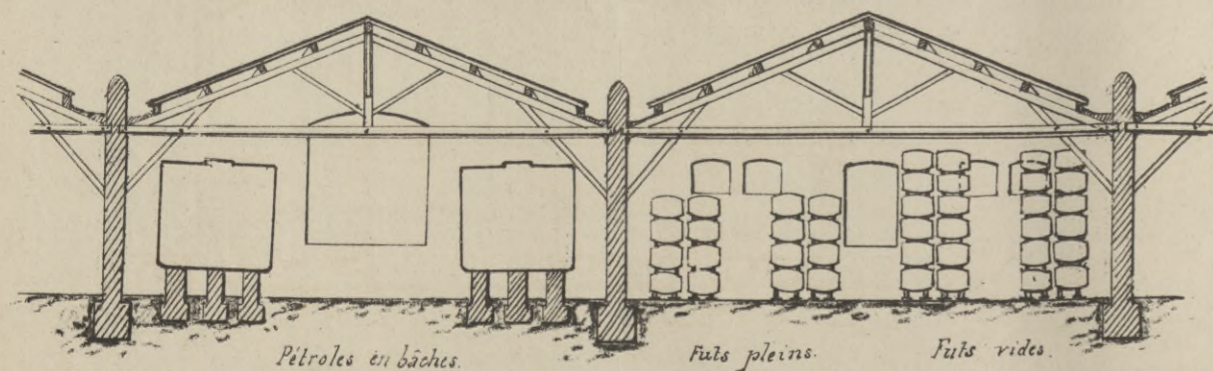

Fig. 229. Magasins pour les spiritueux.

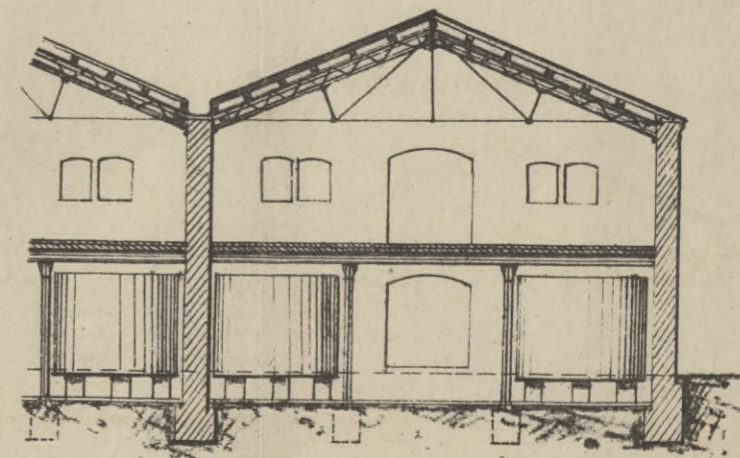





Fig. 232. Grenier mobile d'Auzy, (mod. du grenier Vallery)

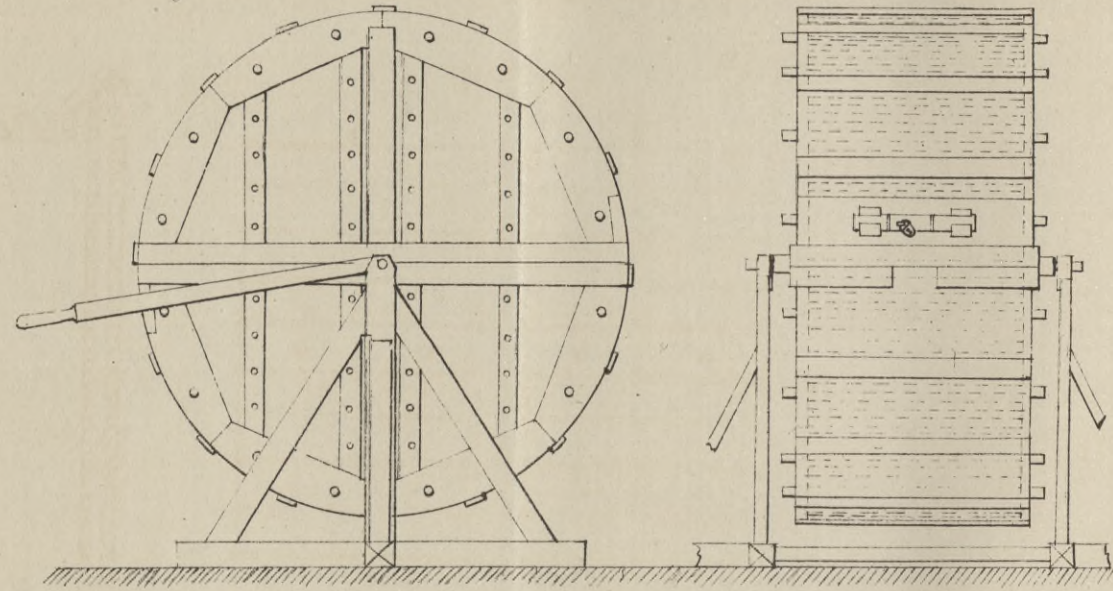

Fig. 233. Grenier-silo Louvel.

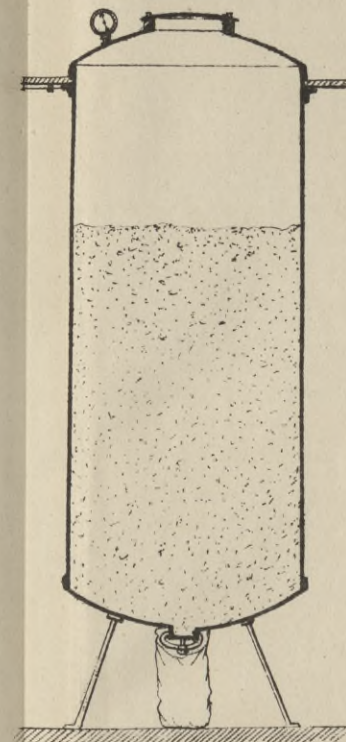
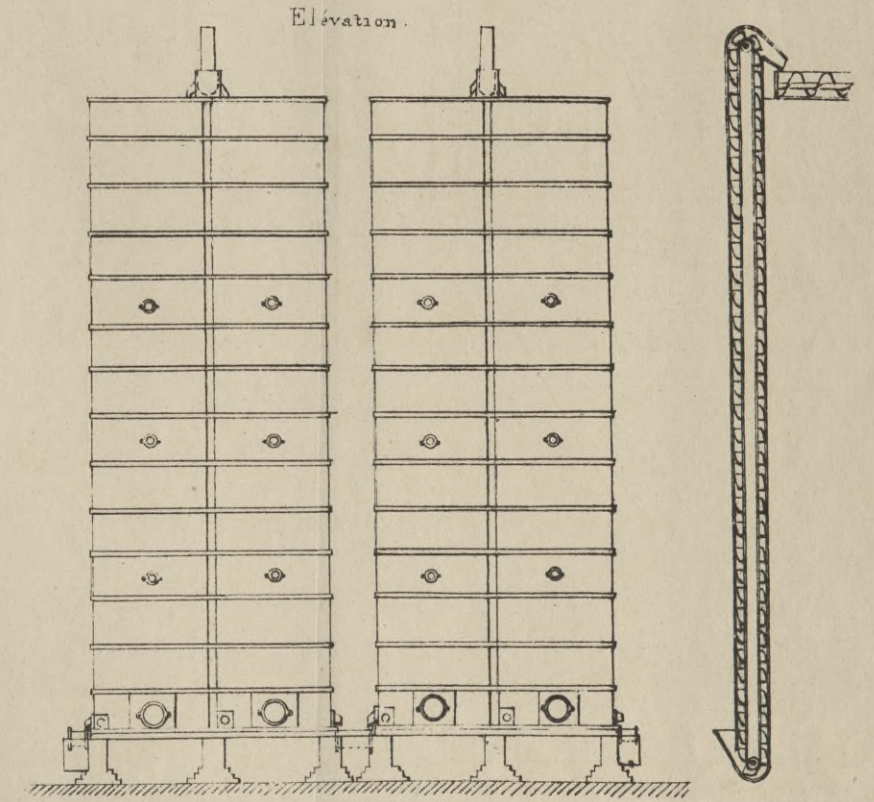

Fig. 234. Grenier Devaux à Londres.



Plan.

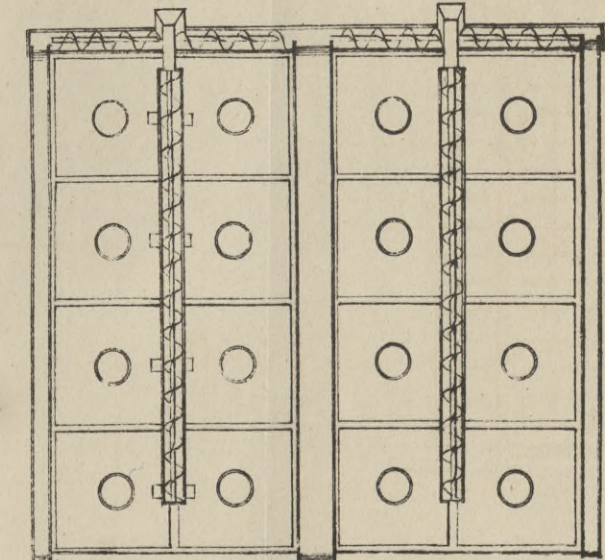

Fig. 236.

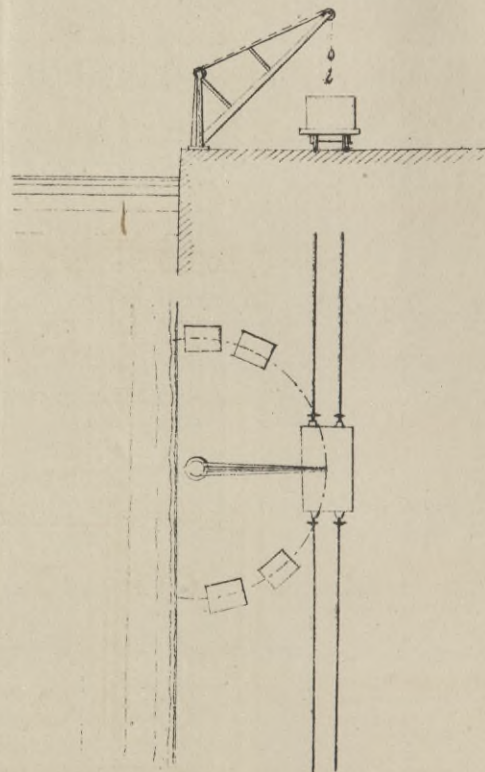

Fig. 237. Grue flottante.

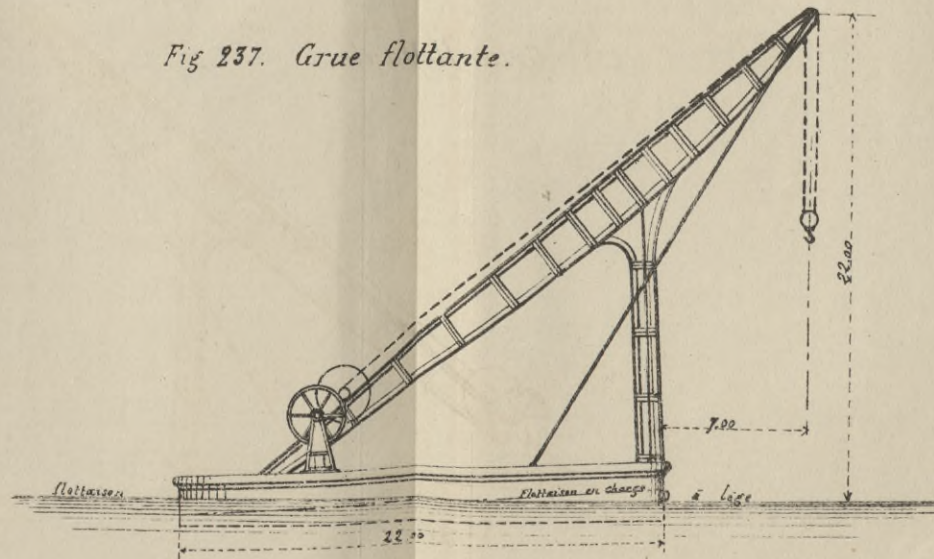

Fig. 235. Silos de Trieste

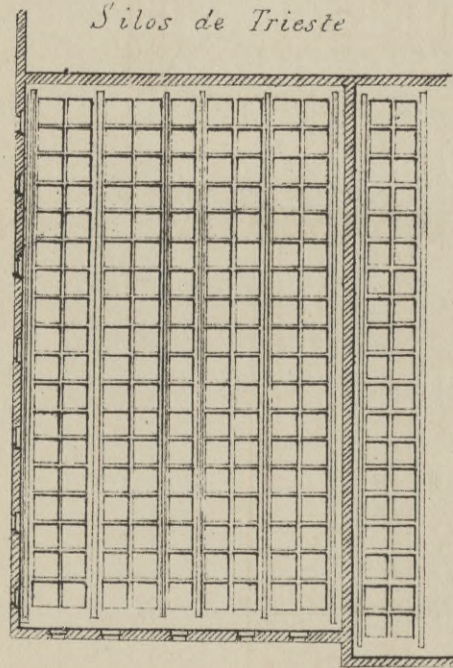





Fig. 239.  
Accumulateur.

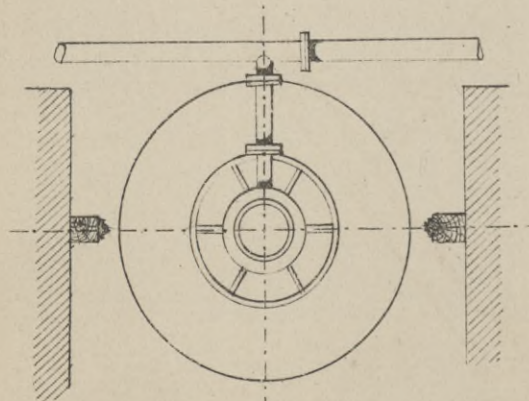
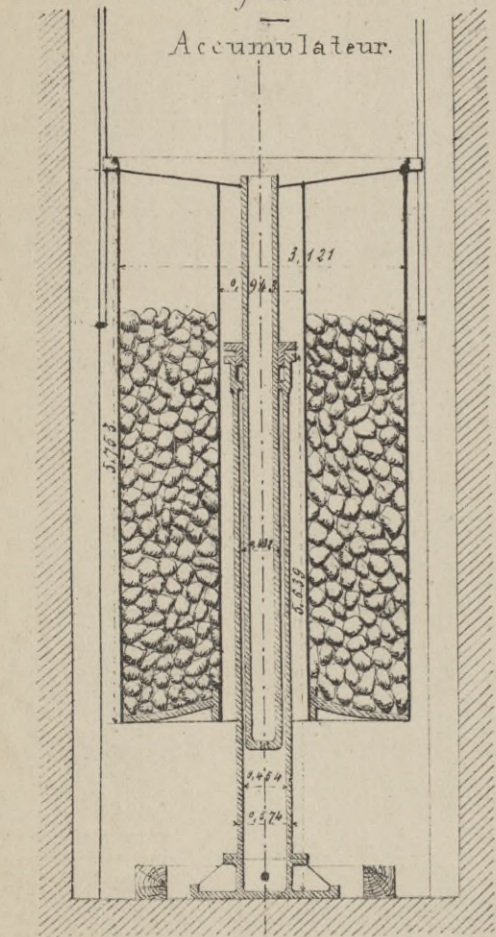

Fig. 238.

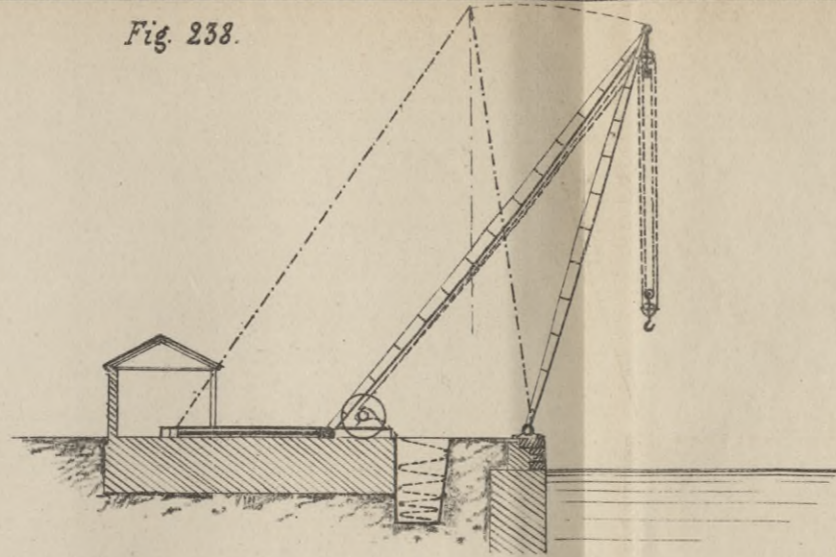

Fig. 241. Exposé graphique du rendement des appareils hydrauliques des docks de Marseille.

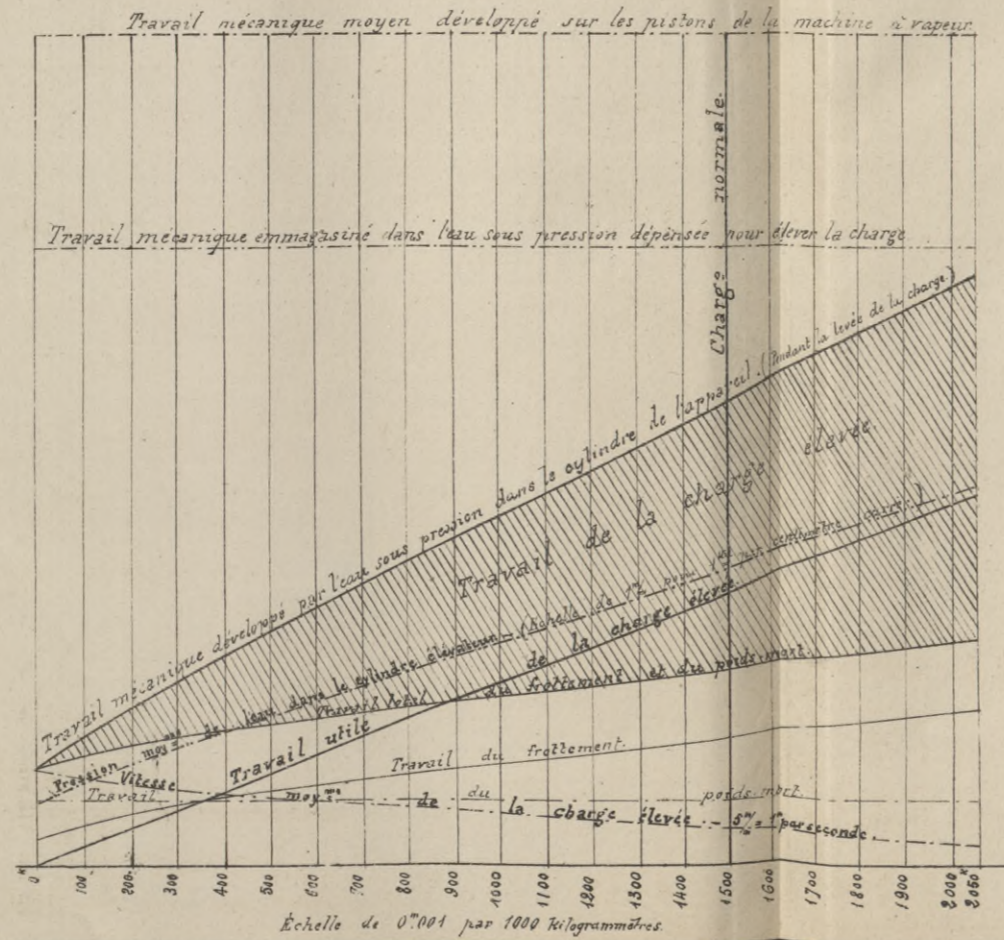

Fig. 240.

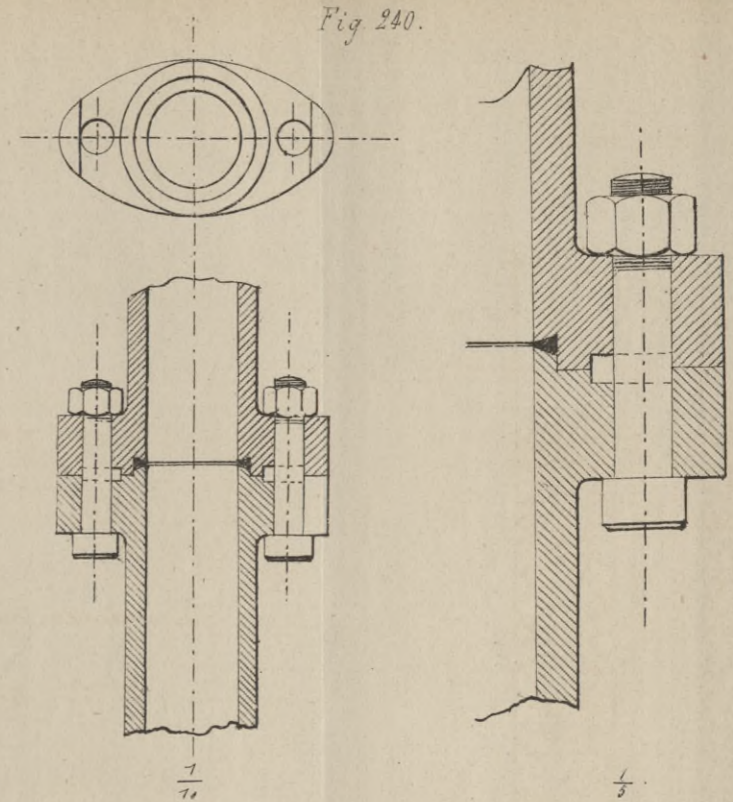

Fig. 242. Grue de 80<sup>tes</sup> de Woolwich.

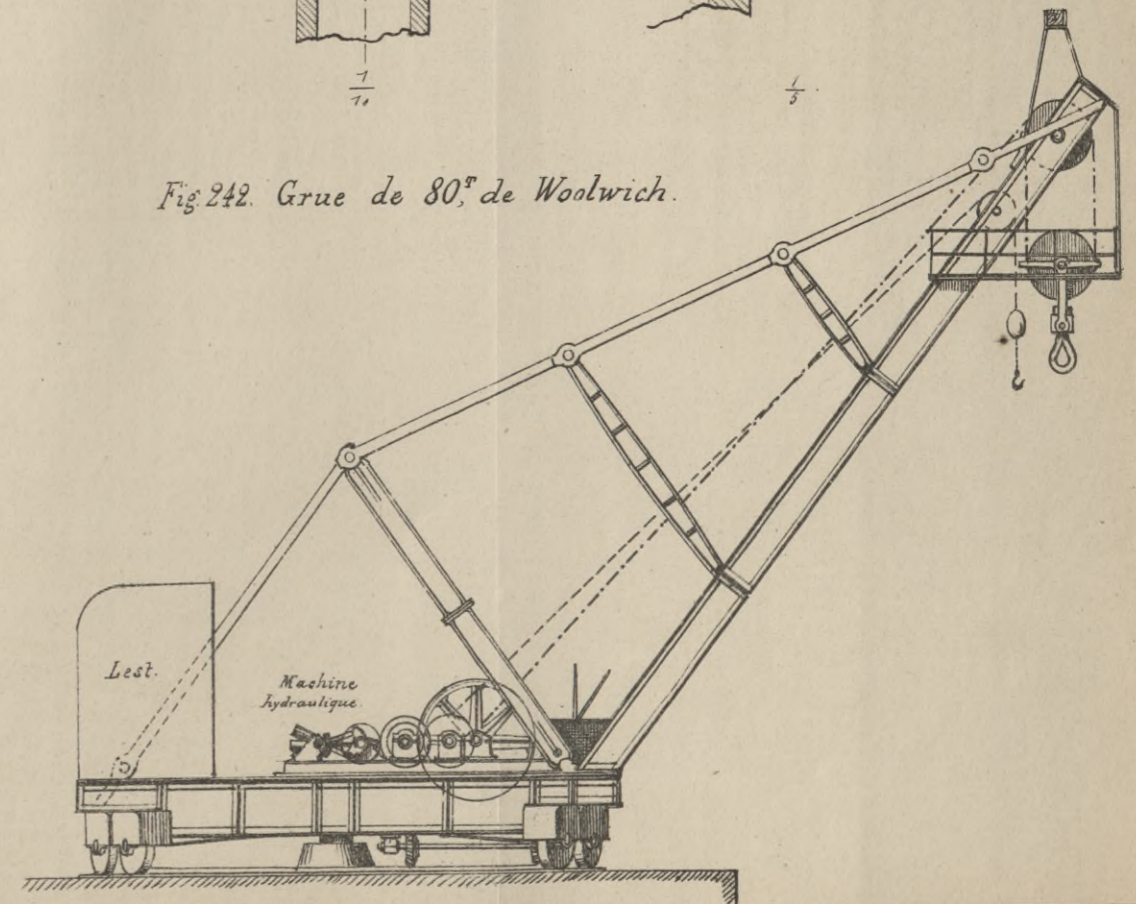







Fig. 243.

Grue de quai .

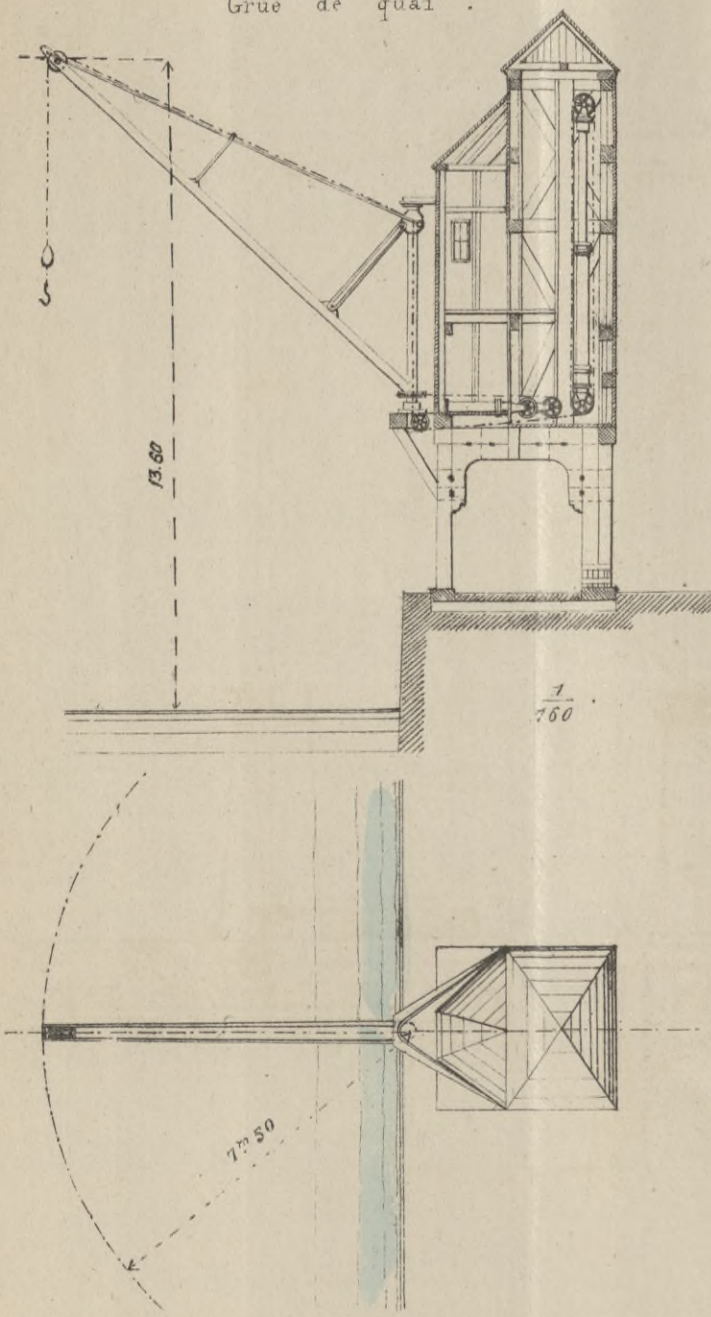

Fig. 244 .

Grue de quai .

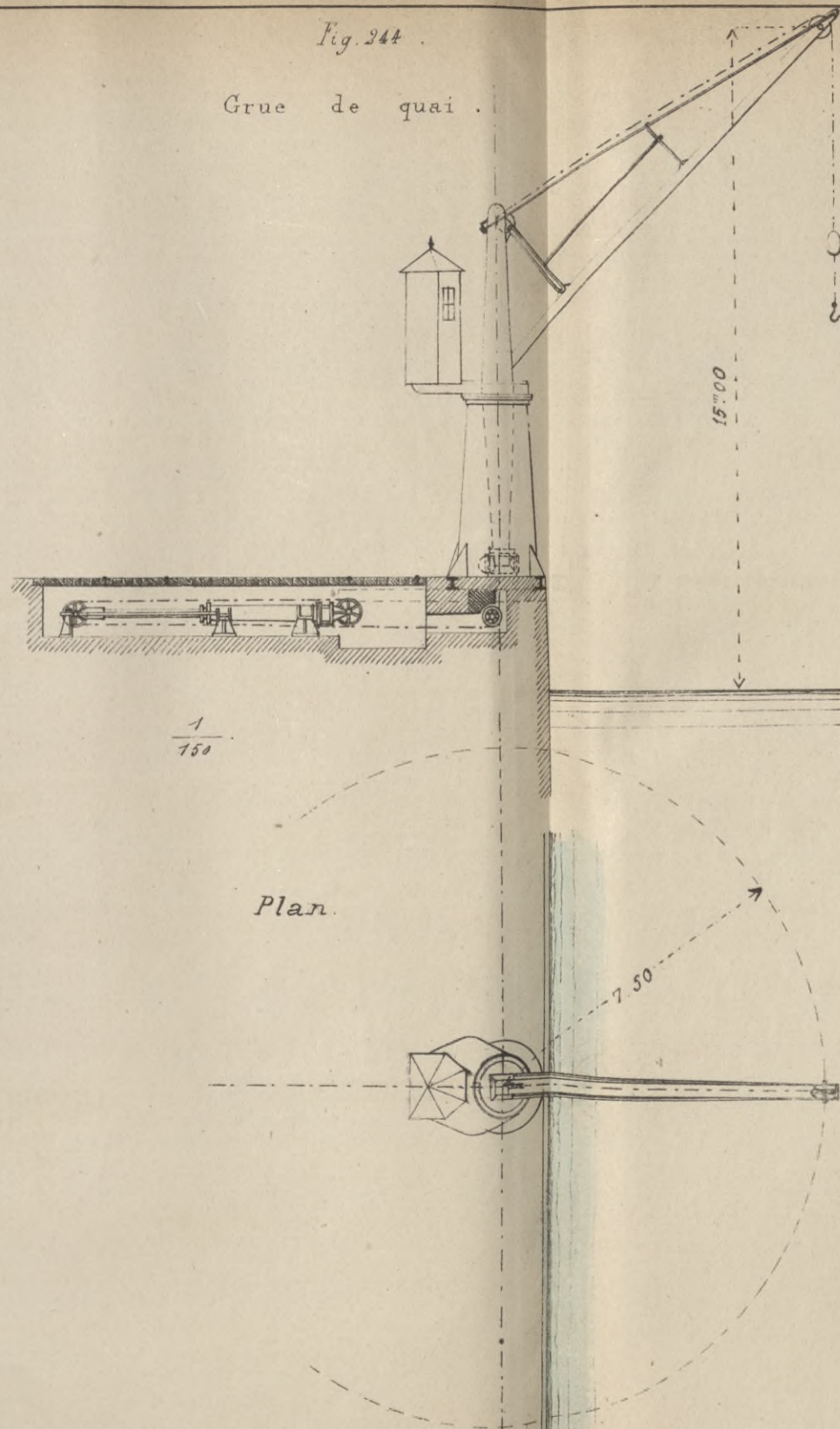

Fig. 245. Grue hydraulique mobile.  
d'une tonne de puissance.

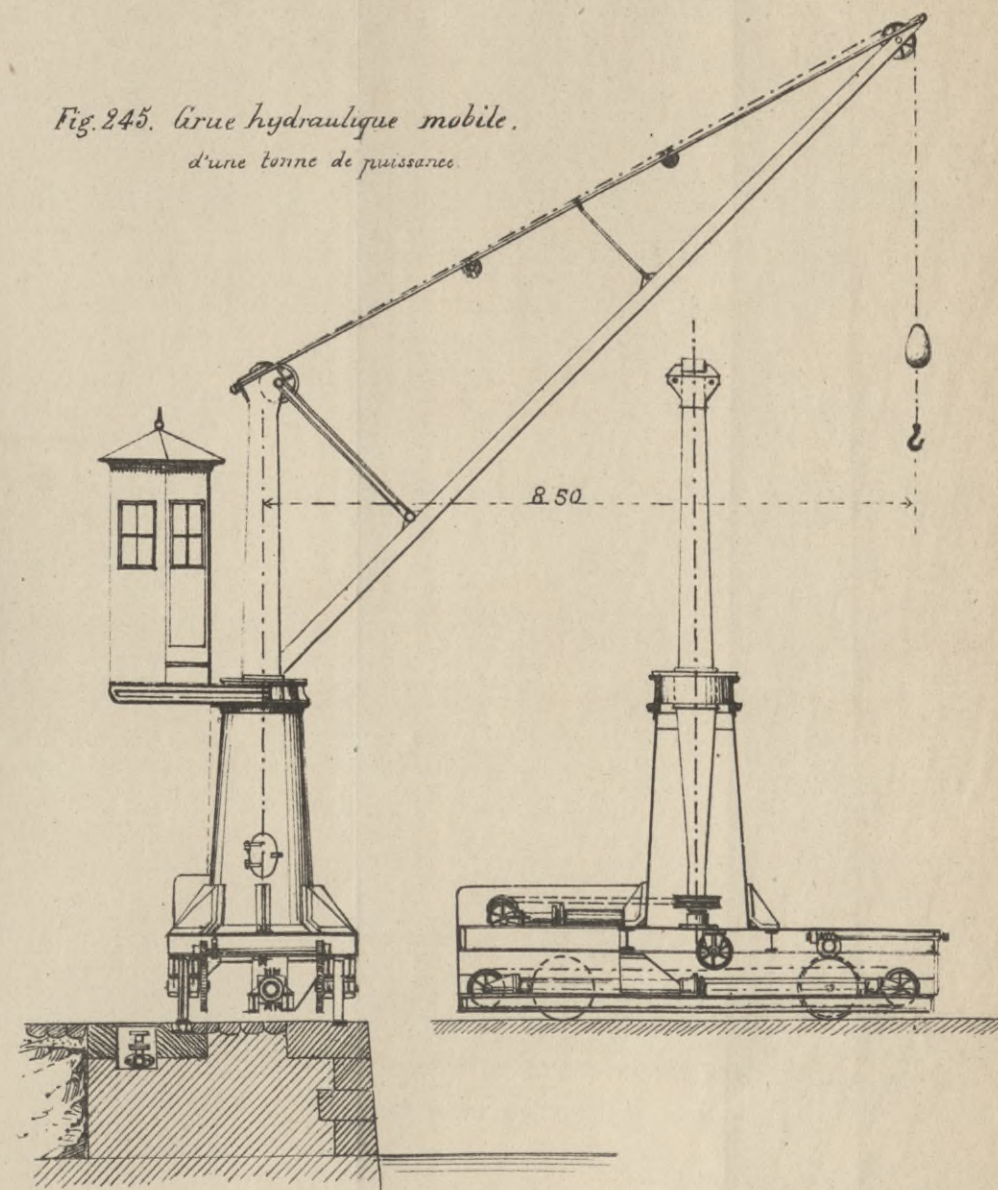
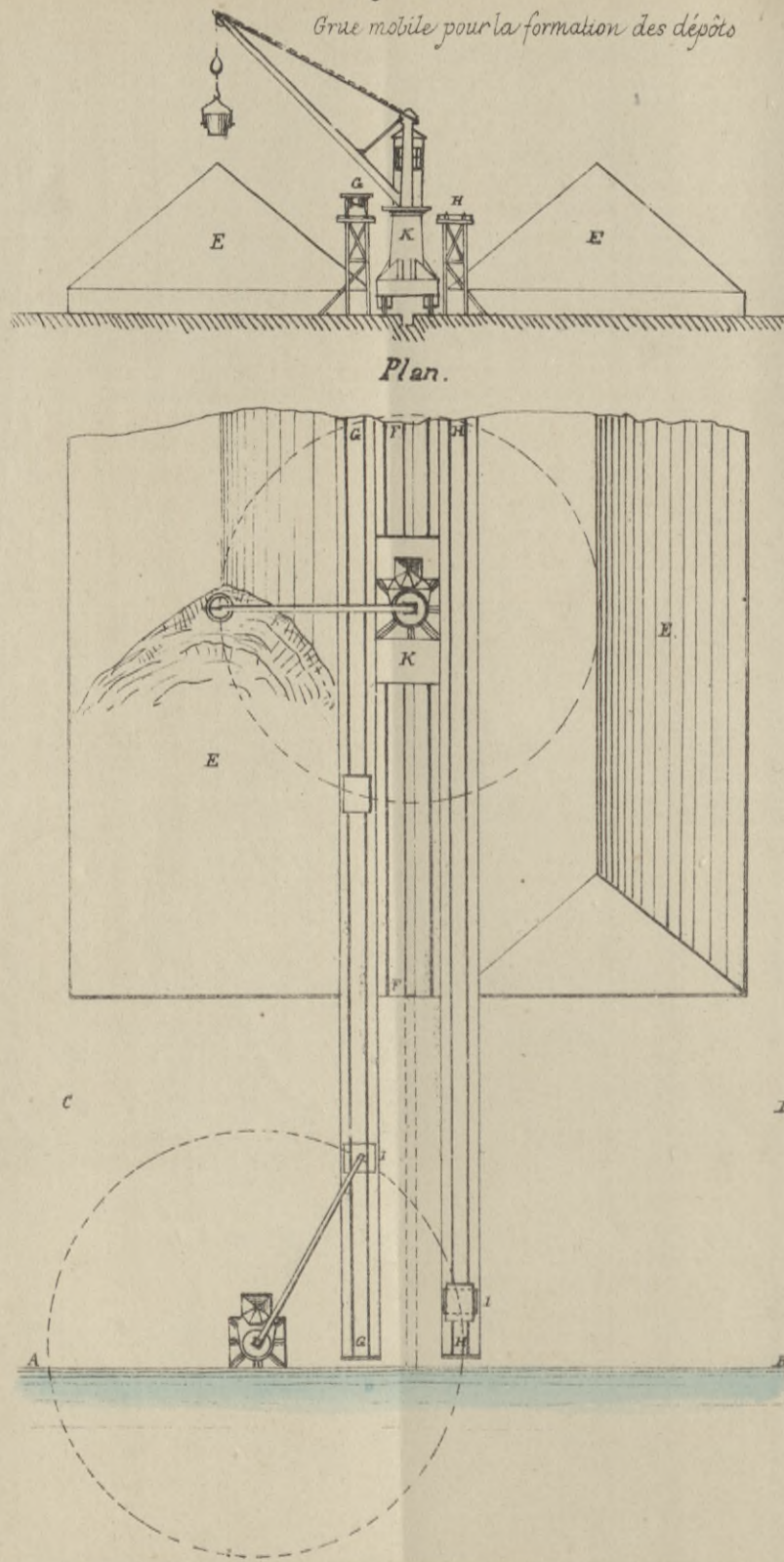





Fig. 245<sup>bis</sup>

Grue mobile pour la formation des dépôts



Plan.

Fig 246. Elevateur.

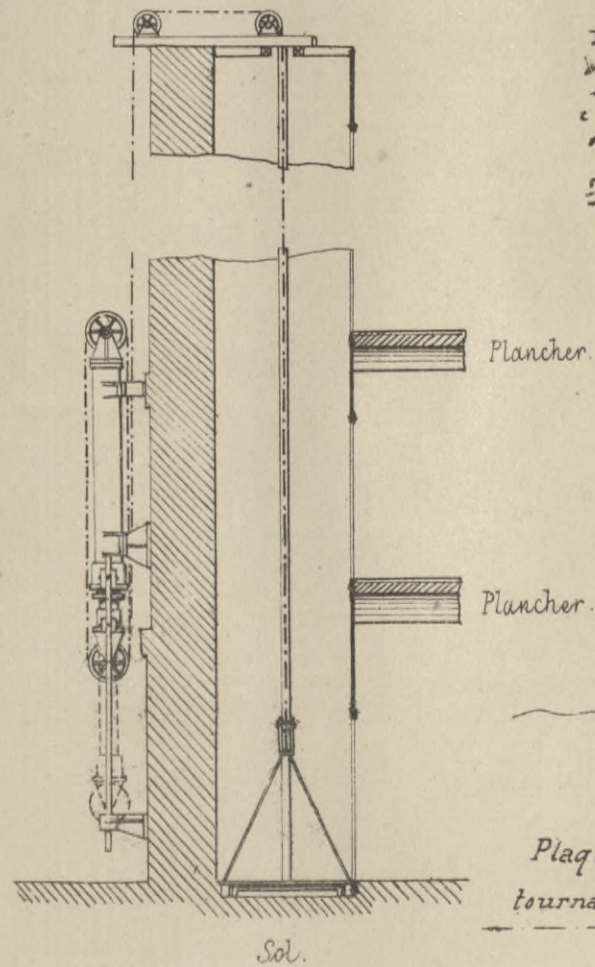

Fig. 247 Cabestan mu par l'eau sous pression.

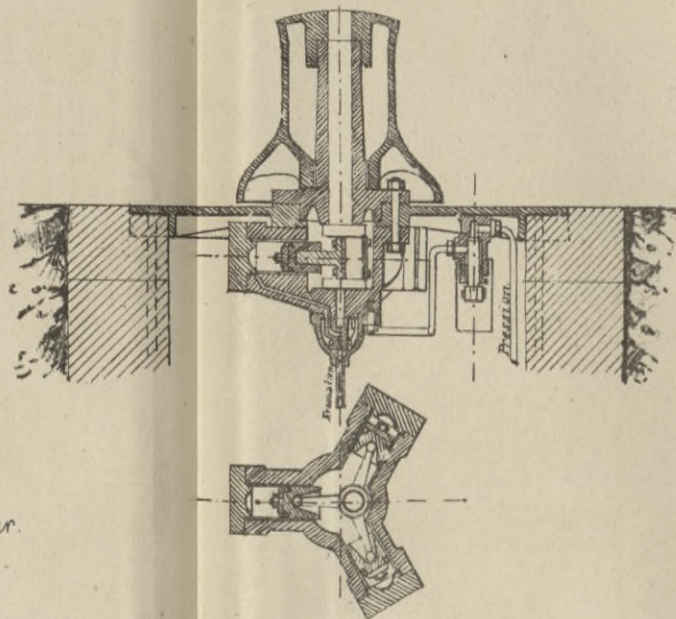

Fig. 248. Monte-charge à action directe.

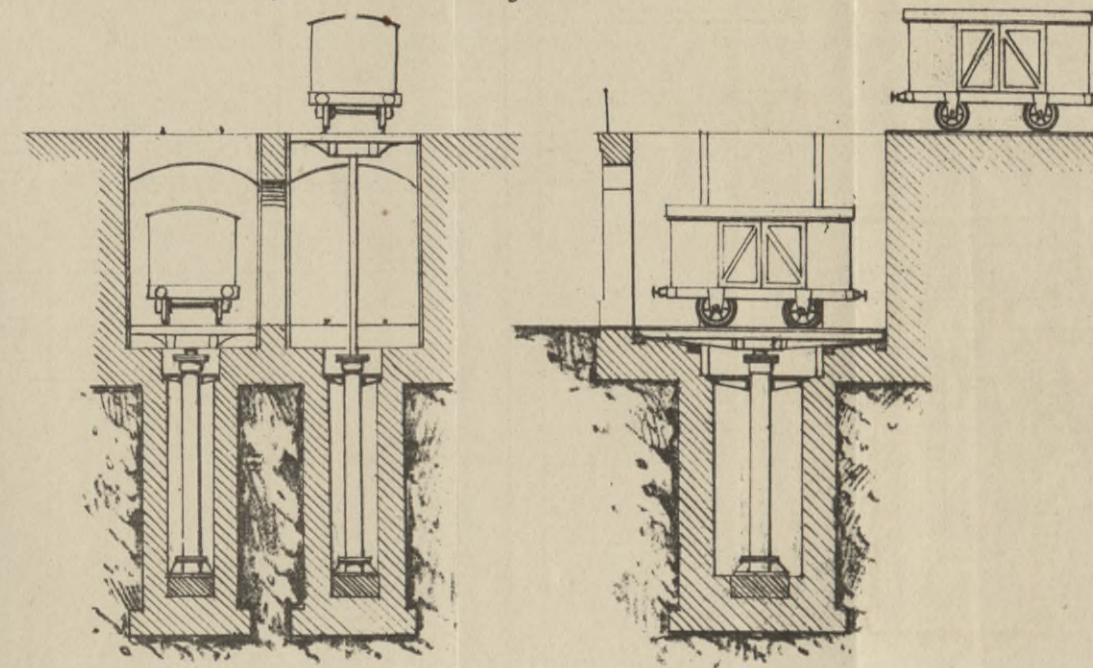

Fig 249. Monte-charge funiculaire.

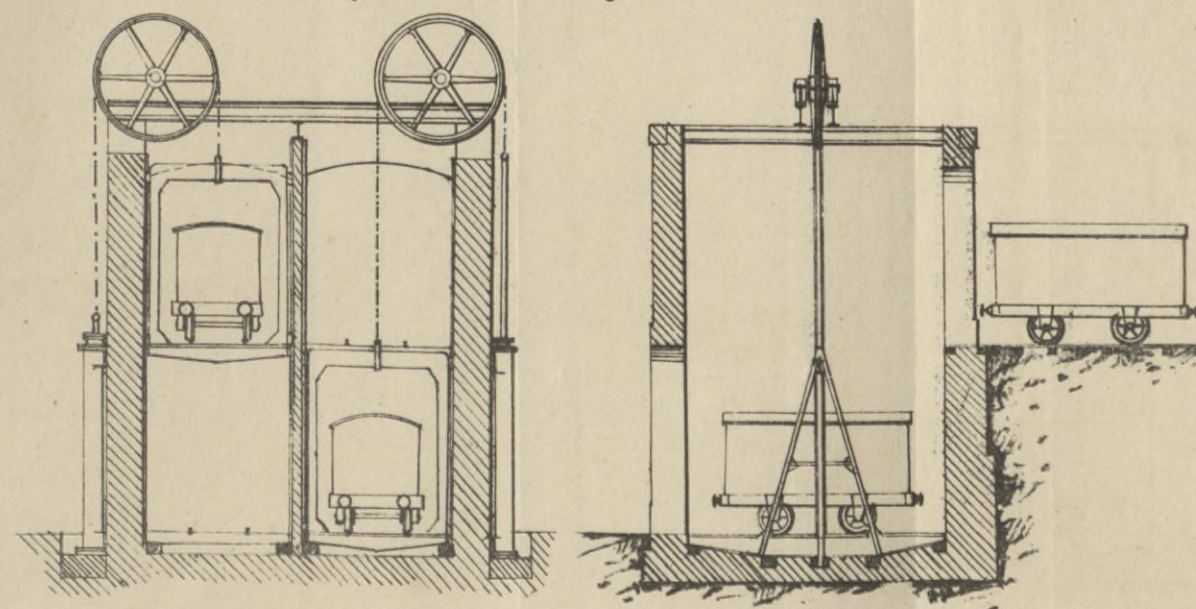

Fig. 250. Plan des appareils de manoeuvre d'une plaque tournante.

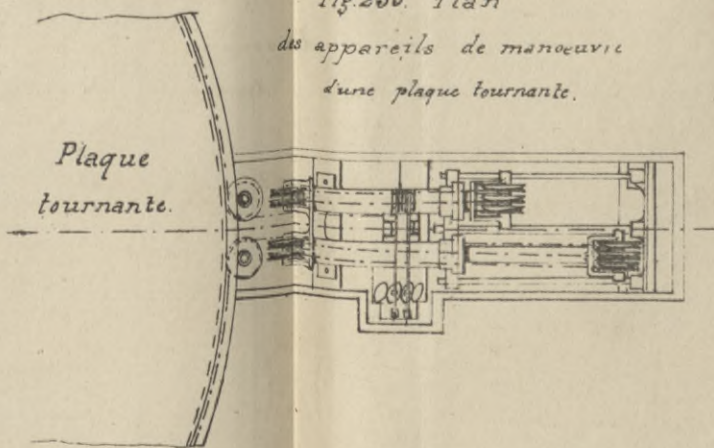







Fig. 251.

Appareils de manœuvre du pont tournant des bassins de radoub de Marseille.

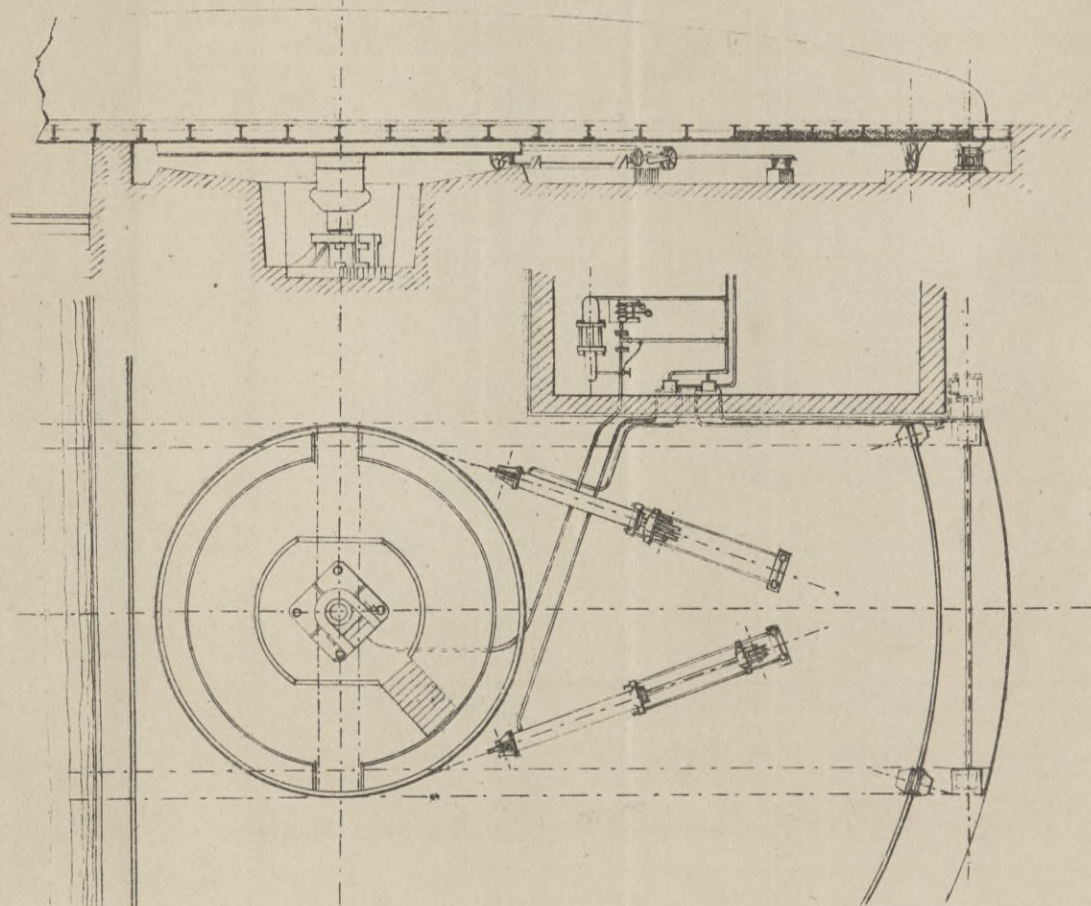

Fig. 252.  
Appareil pour l'ouverture des vannes

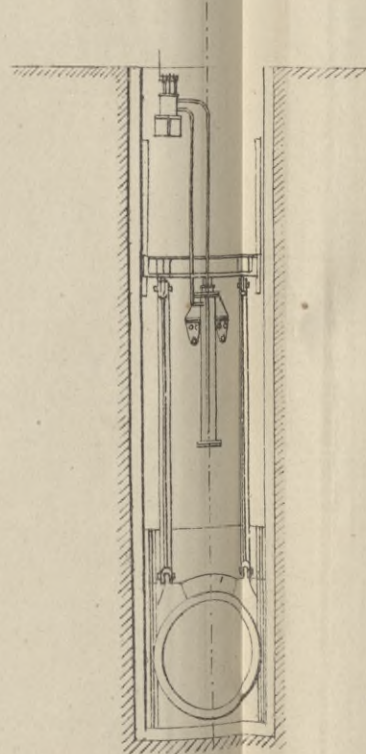

Fig. 253.

Appareils de manœuvre des portes d'écluses de South-Shields.

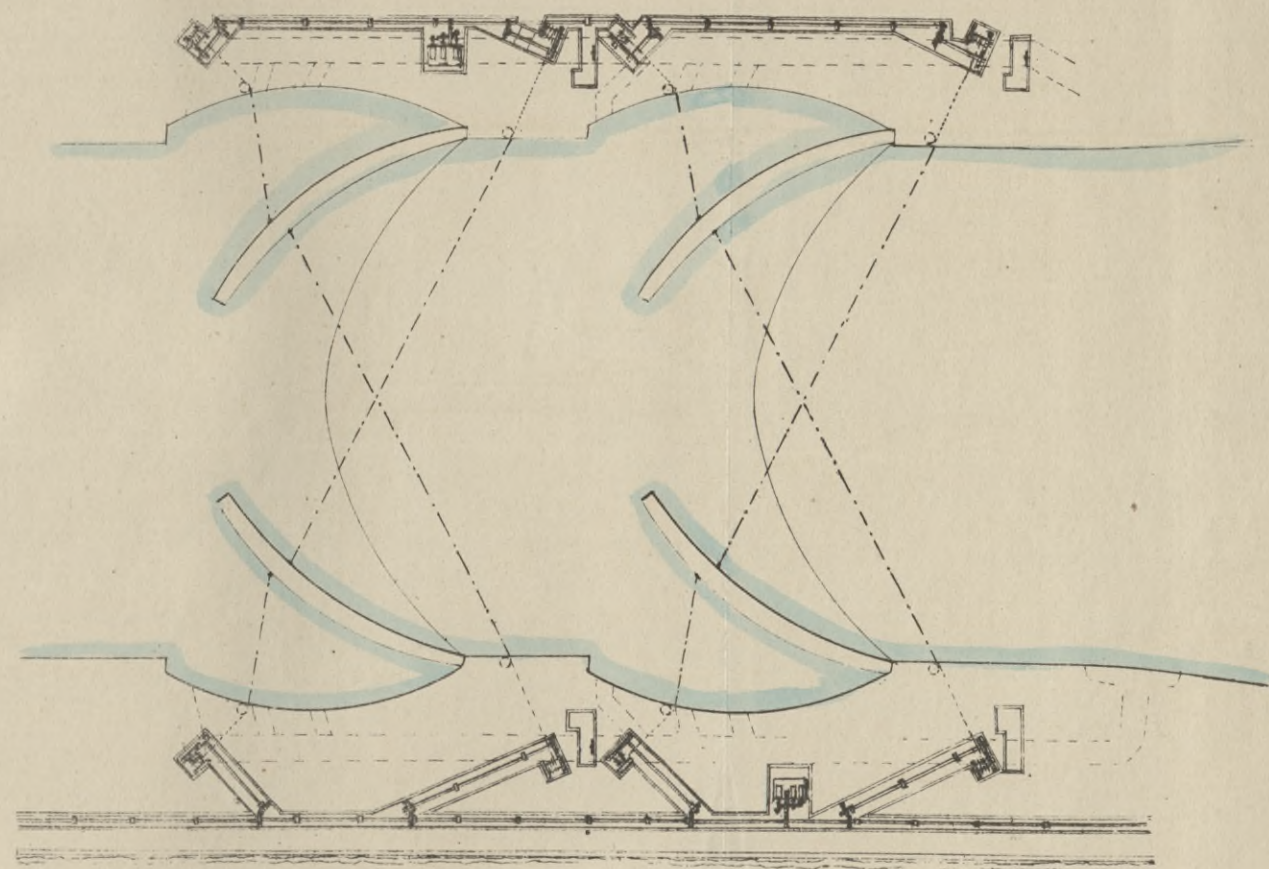





Fig. 254. Élévateur flottant pour le débarquement des céréales.  
(Docks de Marseille.)

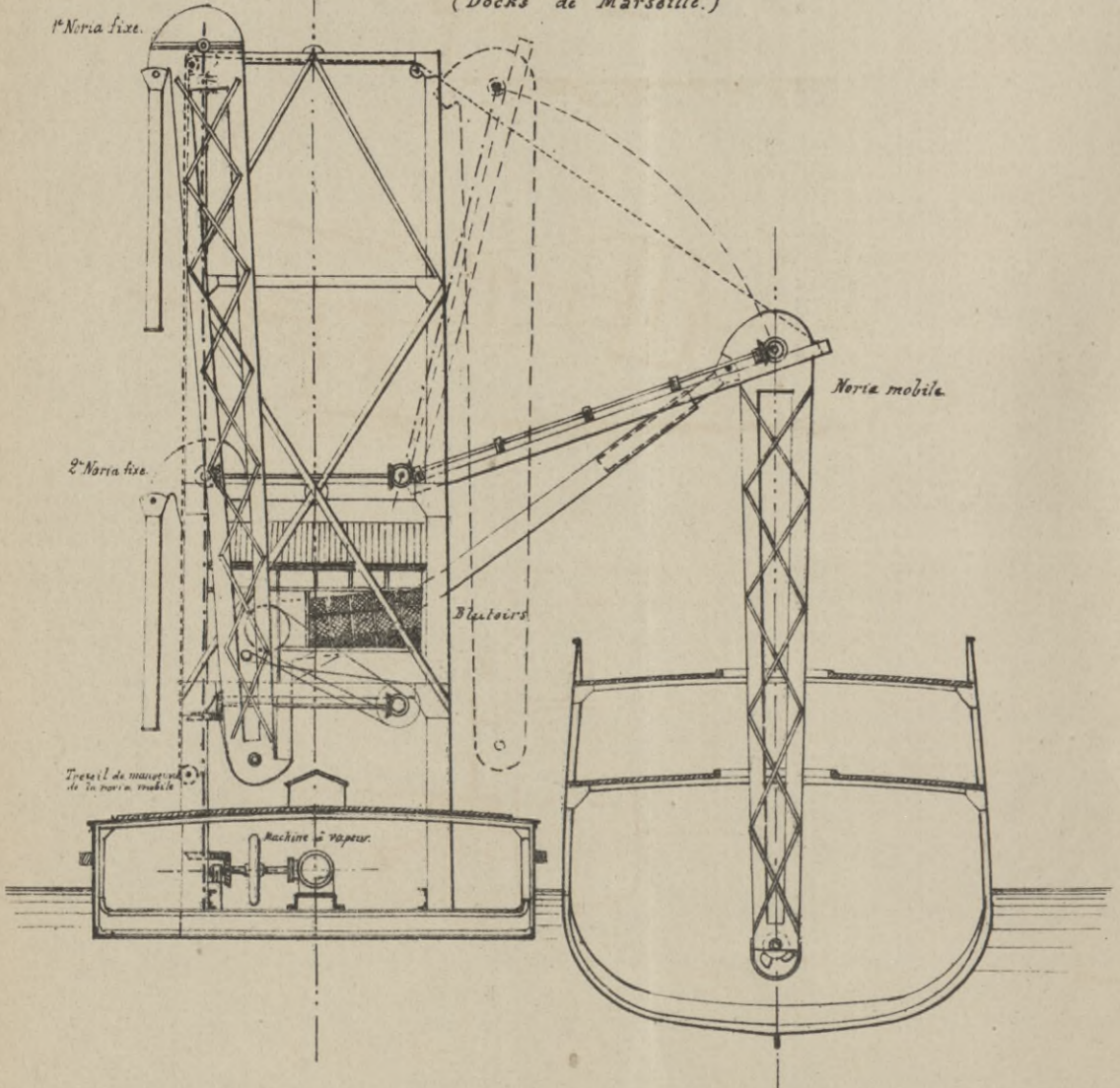

Fig. 256.  
Appareil pneumatique pour le débarquement des céréales.  
Détails.

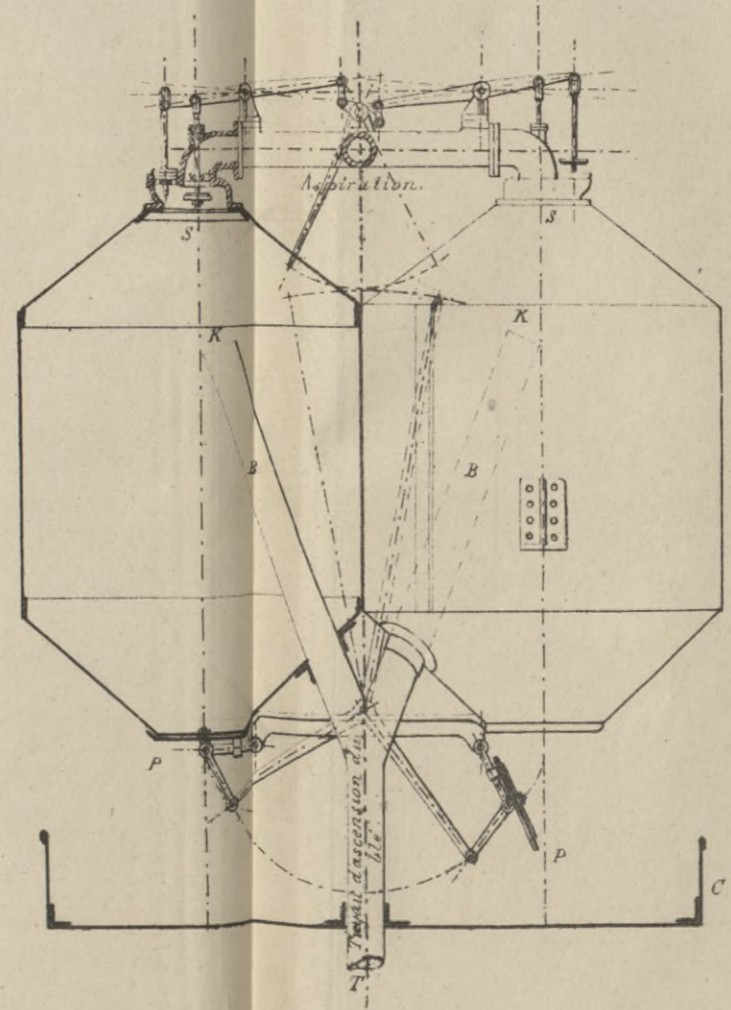

Fig. 257. Abattage en carène.

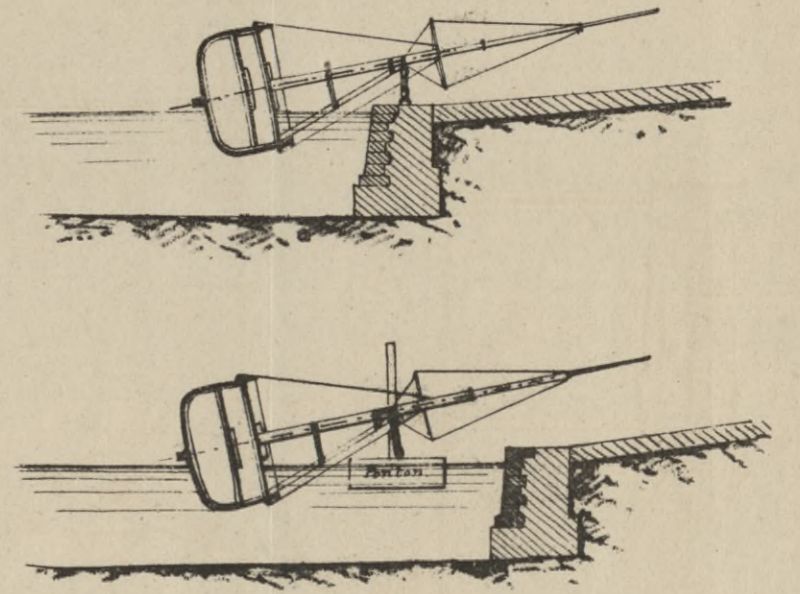
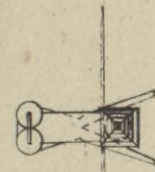
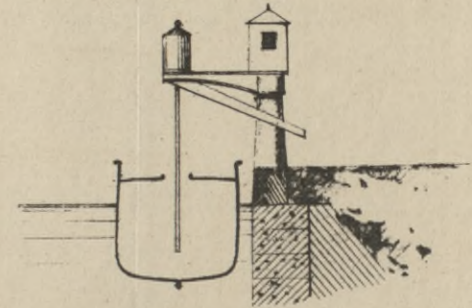

Fig. 255.  
Appareil pneumatique pour le débarquement des céréales.



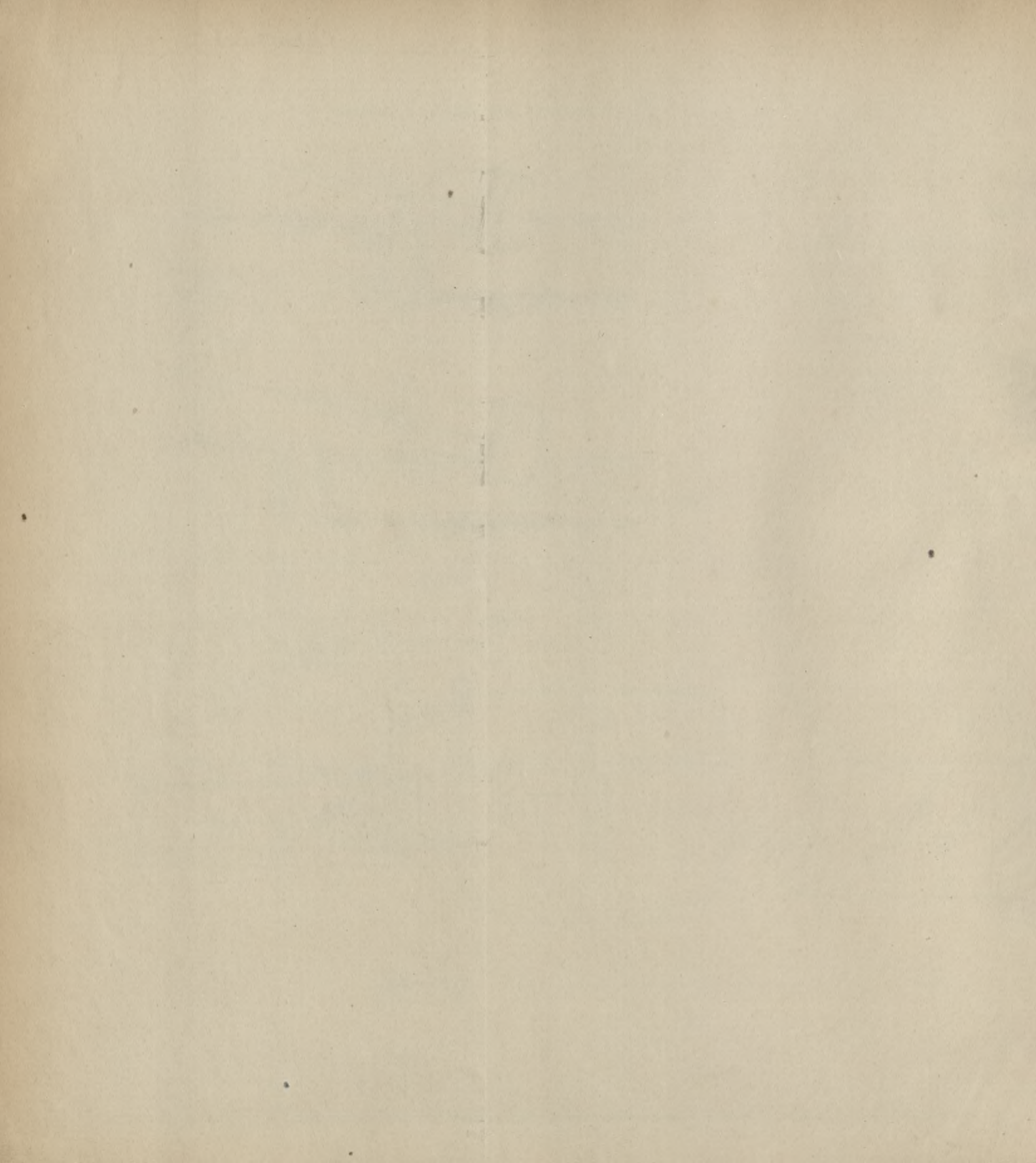



Fig. 258.  
Gril à marée de Dieppe.

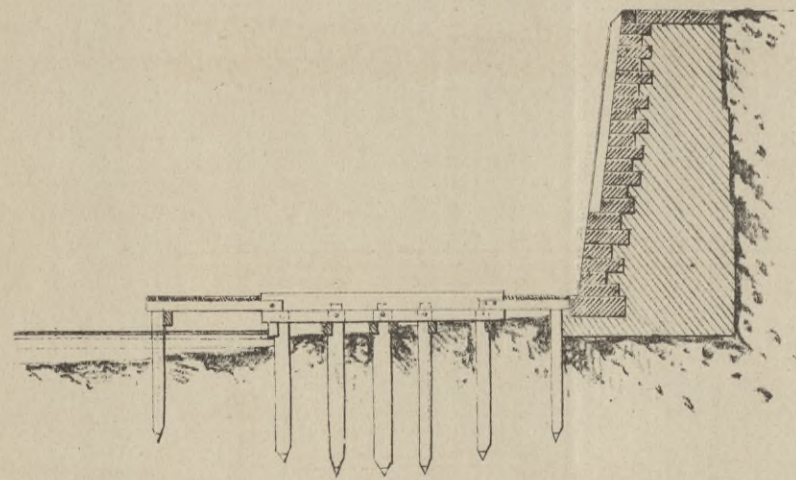

Fig. 260.

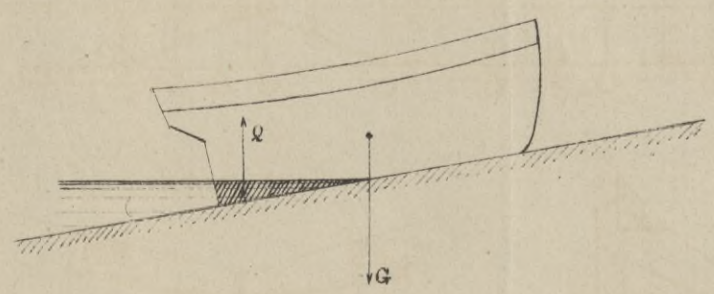

Fig. 259. Cale de halage de la Seyne.

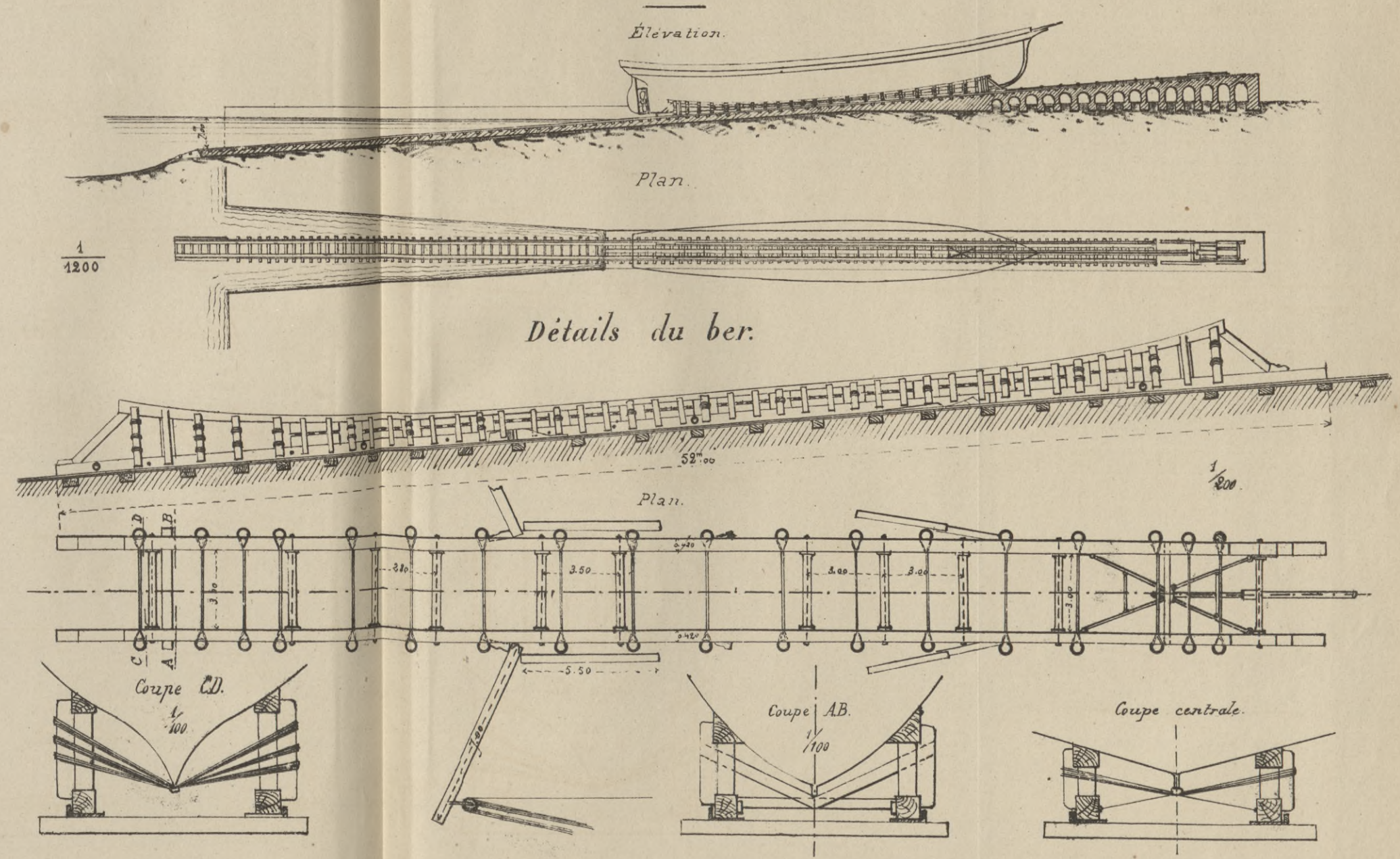
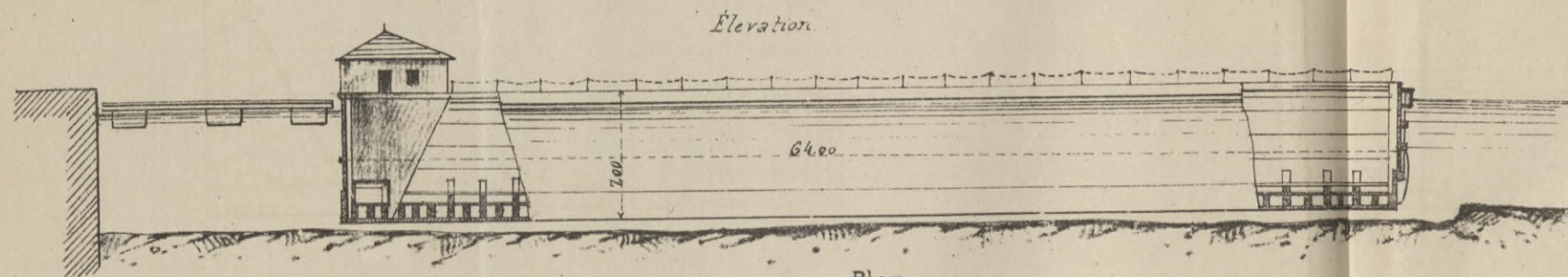







Fig 261. Forme flottante en bois, de Marseille.



Elevation.

Coupe AB.

Plan.

Coupe CD.

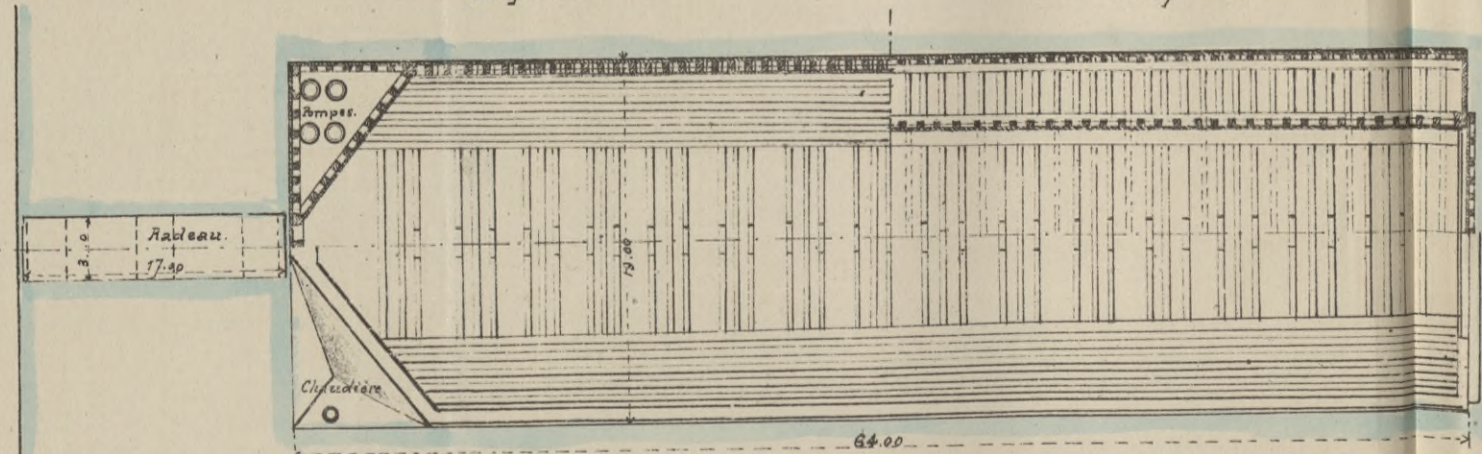

1/400

Coupe transversale

Elevation de la porte.

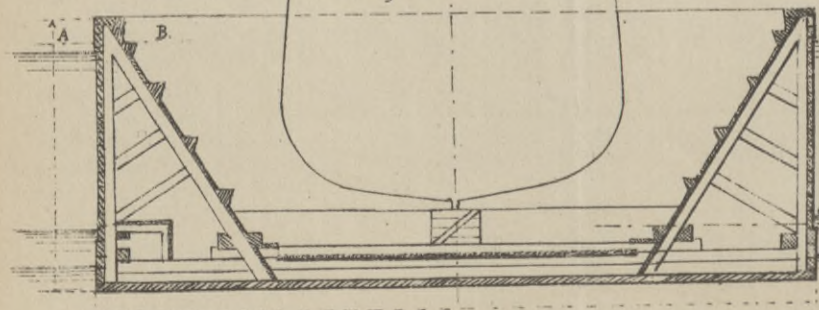

1/200

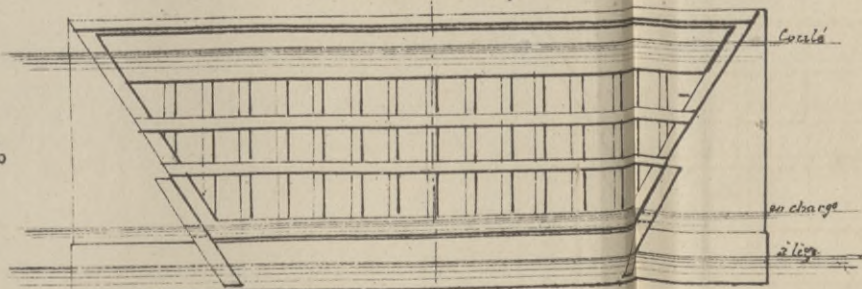

en charge à l'ég.

Fig. 262.  
Forme flottante en fer.

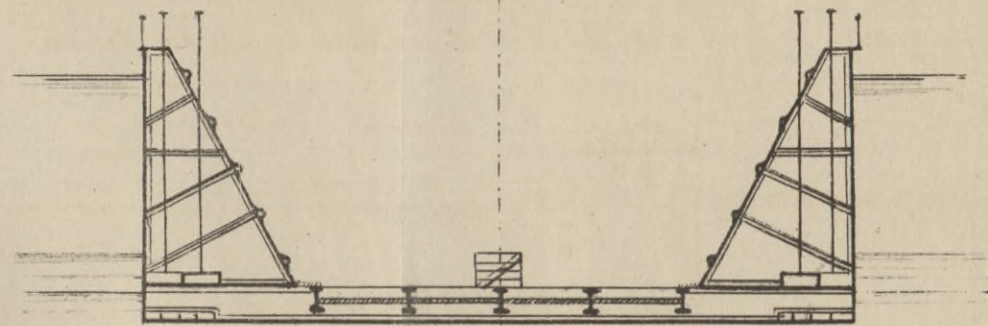

Fig. 263.  
Forme flottante des vaisseaux de la marine Espagnole.

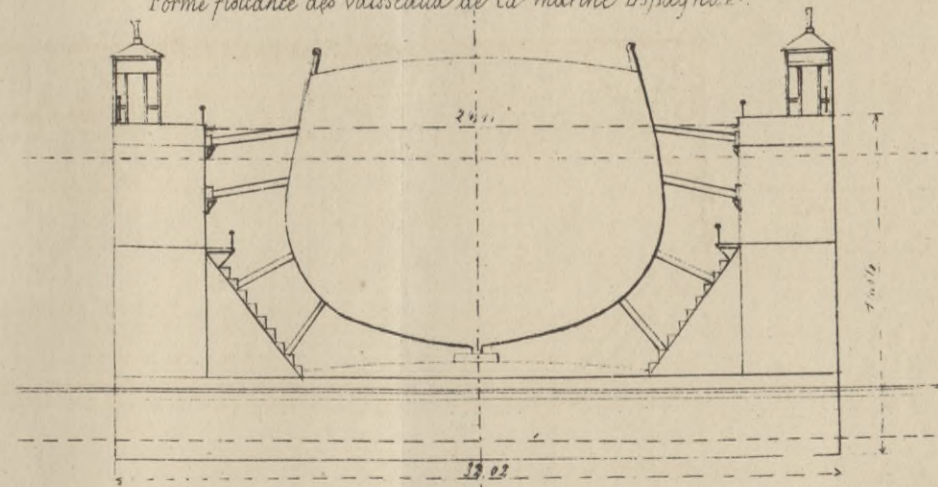

Fig 264.

Plan d'ensemble.

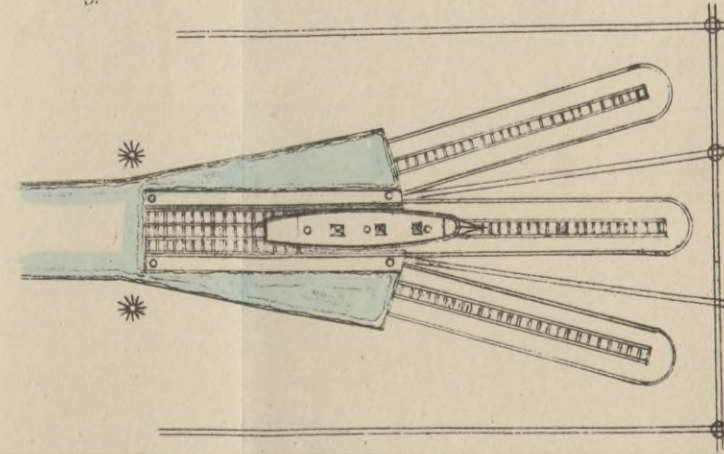
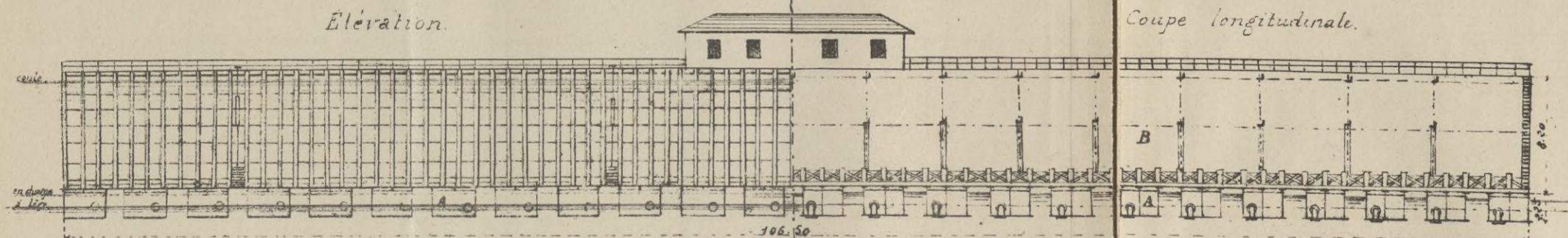

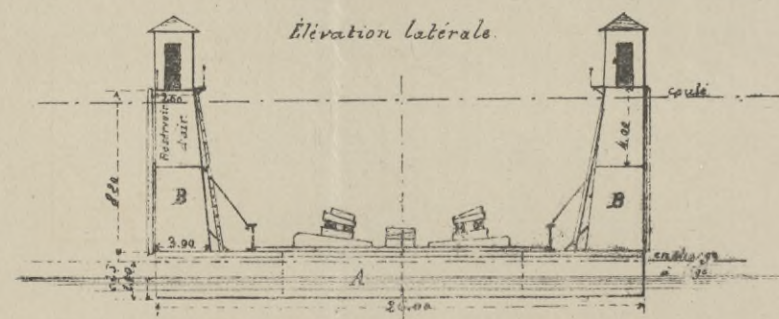
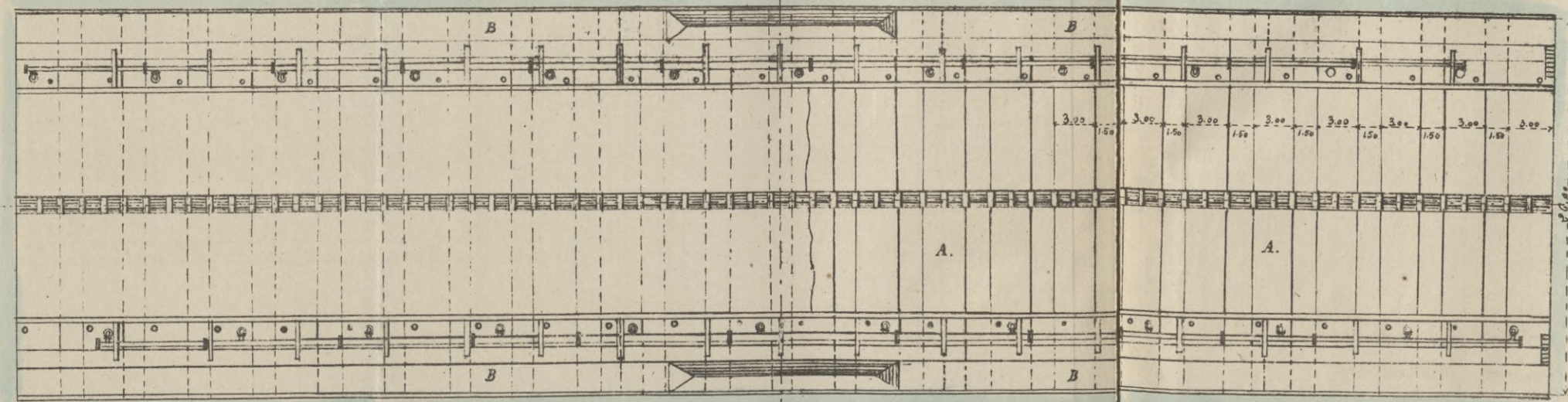



Fig. 265. Dock flottant démontable en fer.



*Plan.*



1/400

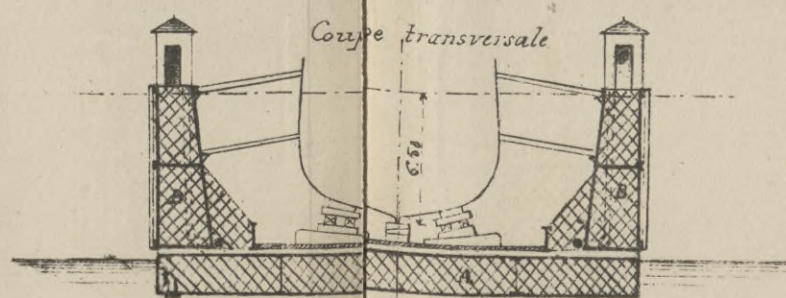

Fig. 266.

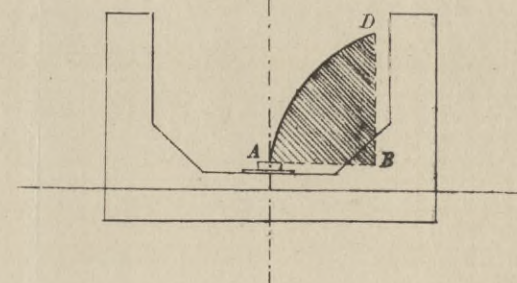

Fig. 267.

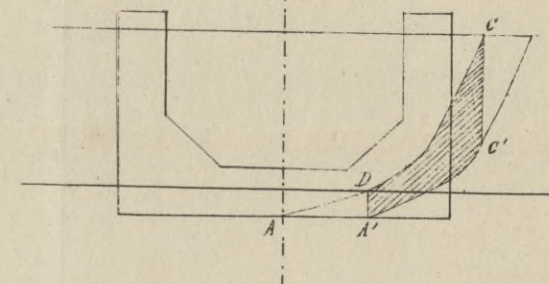

Fig. 268.

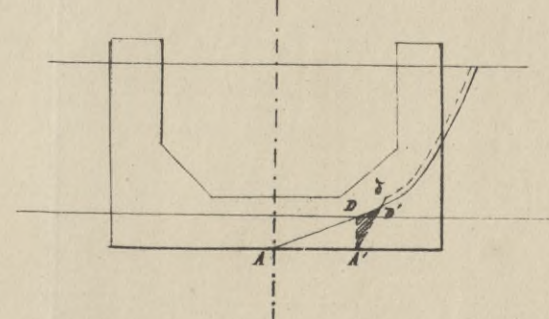
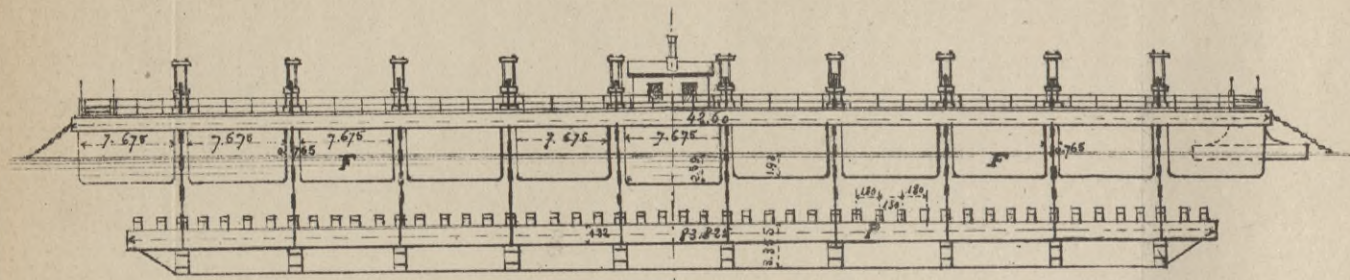



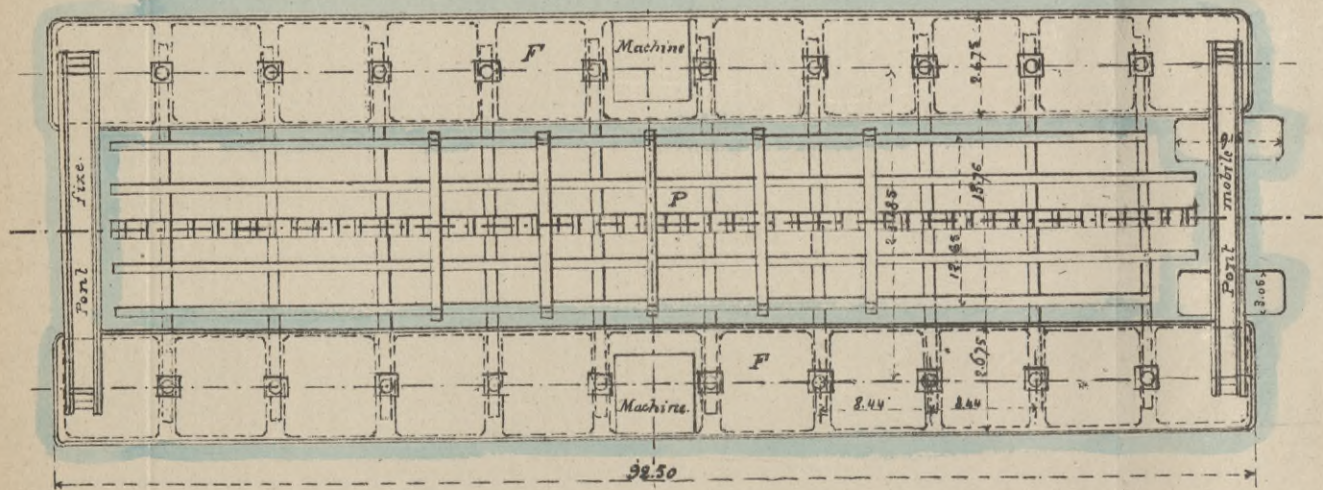

Fig. 269. E'leveur flottant hydraulique, Systeme Walker.

E'levation.



Plan.



E'levation laterale.

E'levation laterale faisant voir la position du navire lorsqu'il a e'te' e'leve'.

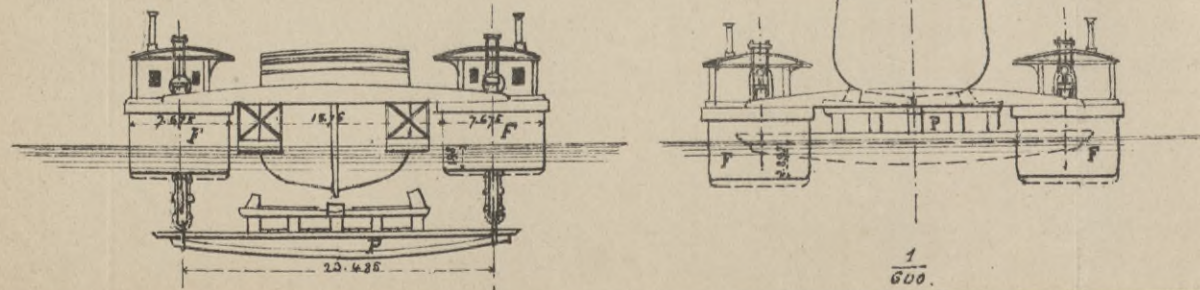
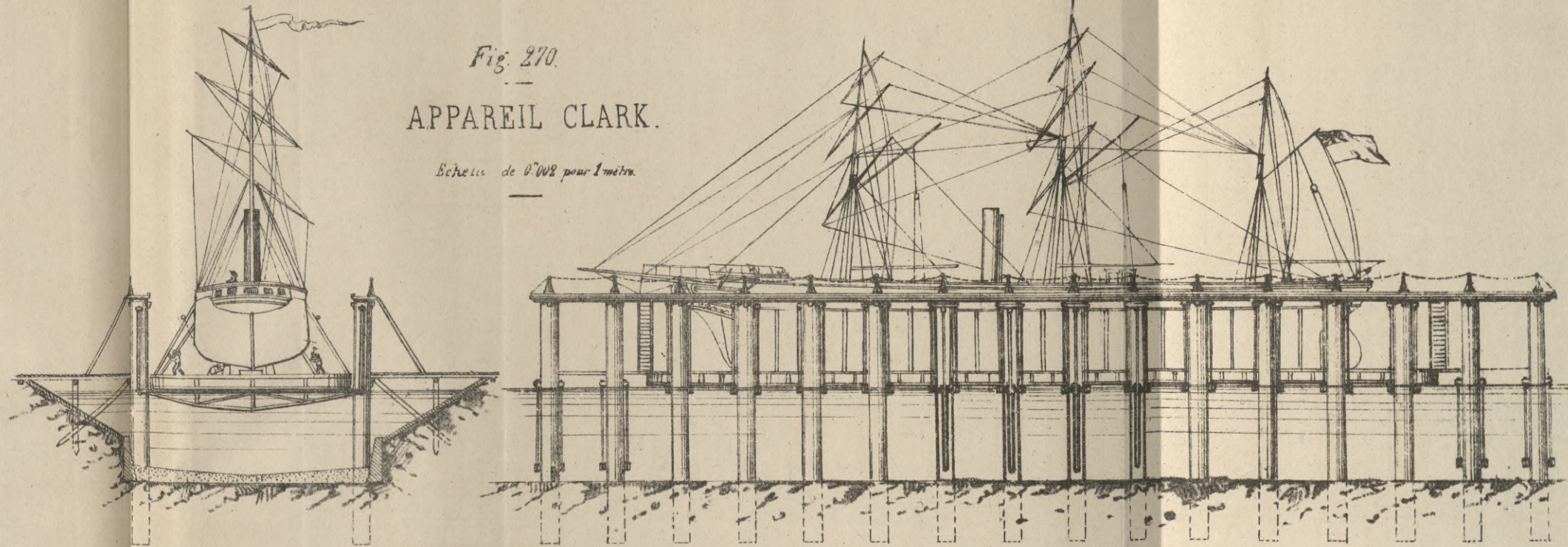

Fig. 270. APPAREIL CLARK.

Echelle de 0.002 pour 1 metre.

E'levation.



Plan general.

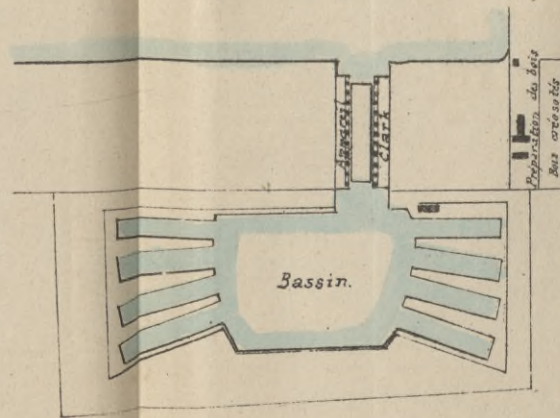

1/7200

Plan.

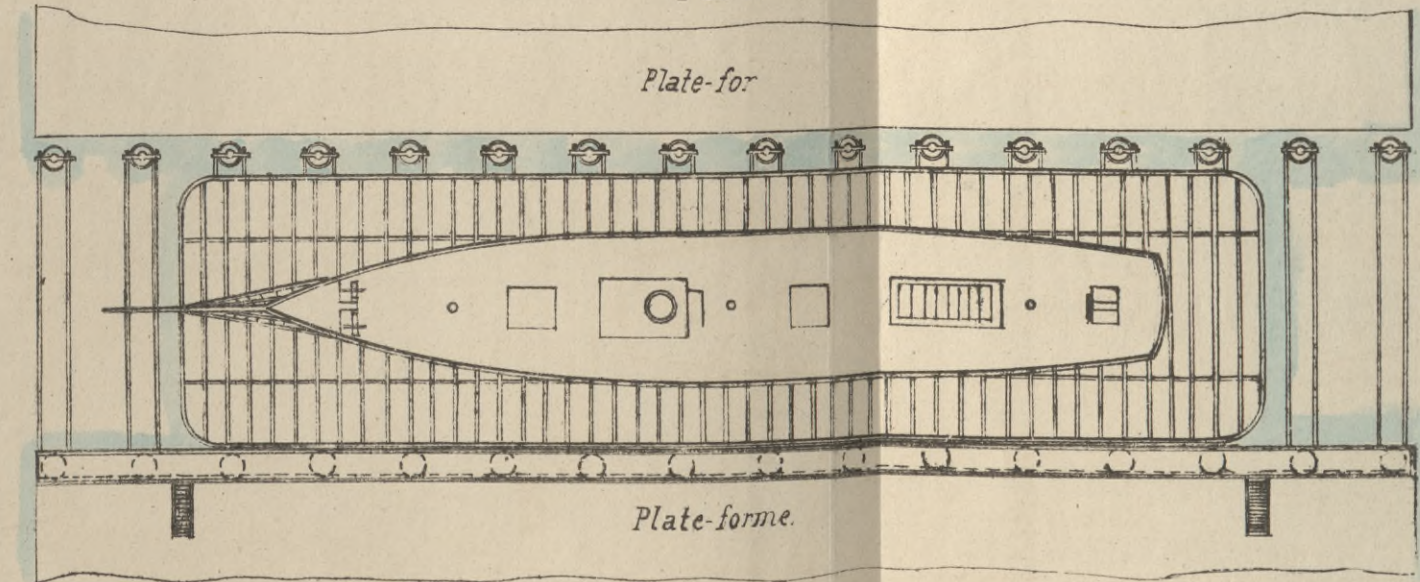







Fig. 271.

Ponton de l'appareil Clark projeté pour le port de Marseille.

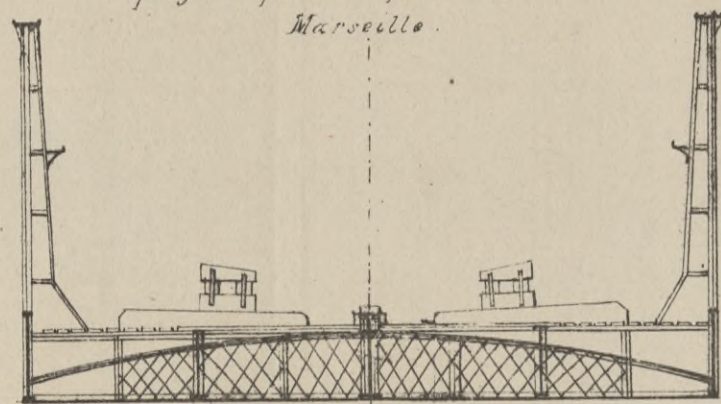

Fig. 273.

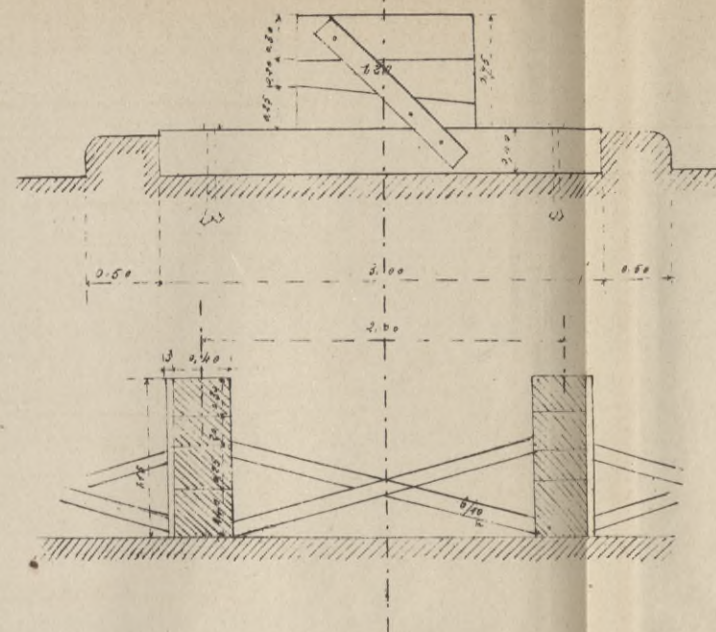

Fig. 274. Plan des bassins de radoub de Marseille.

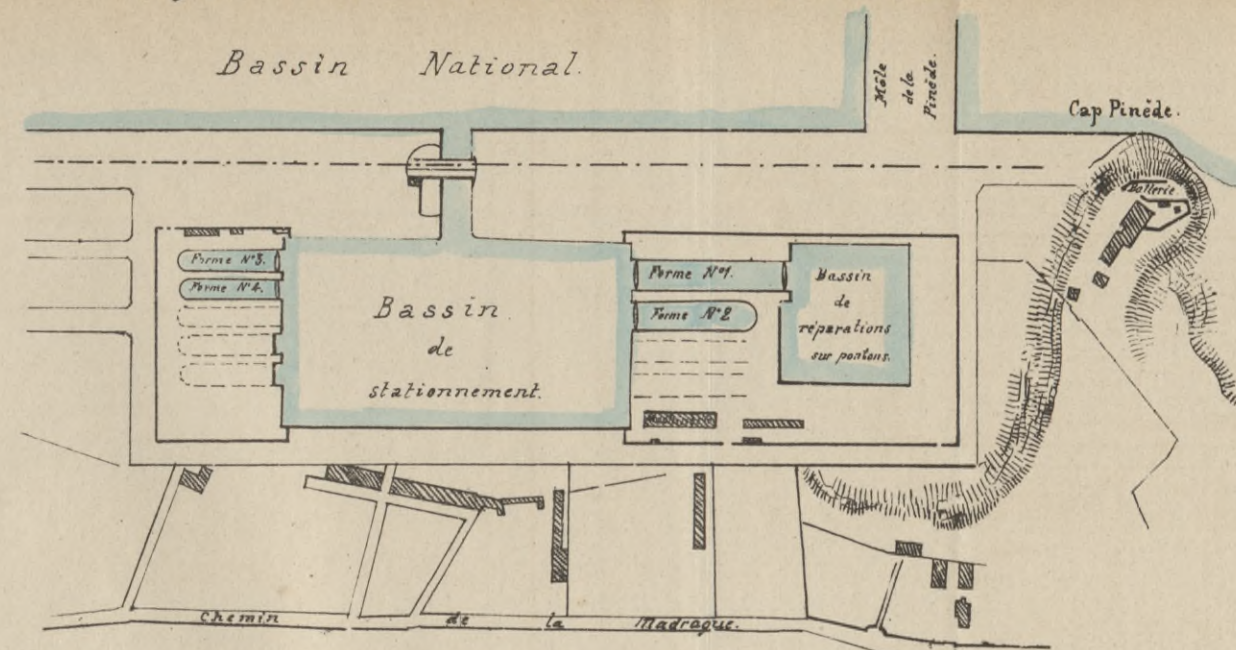

Fig. 274 bis

Forme N°1 de Marseille.

Plan

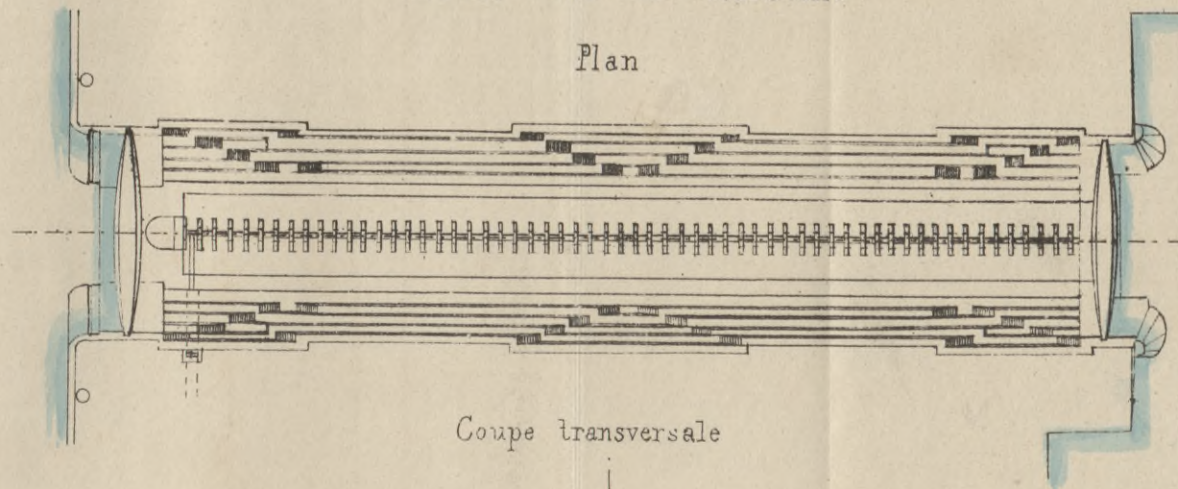

Fig. 272.

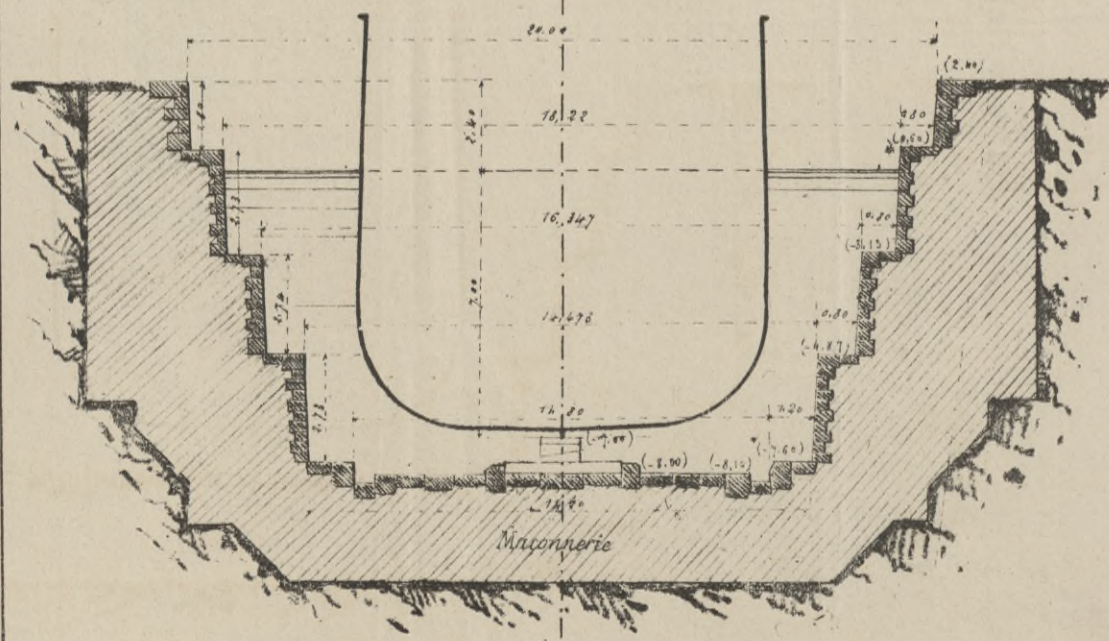
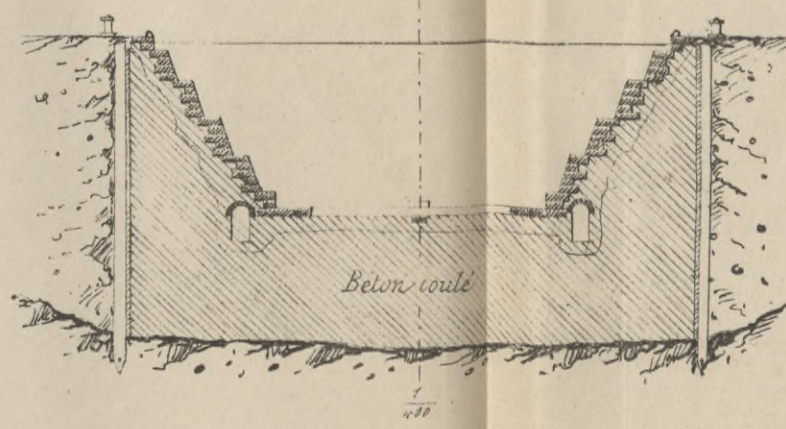

Fig. 275

Forme sèche N°2 de Castigneau.



Coupe transversale

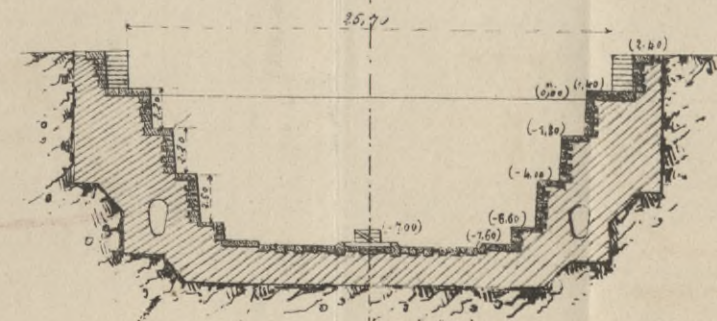

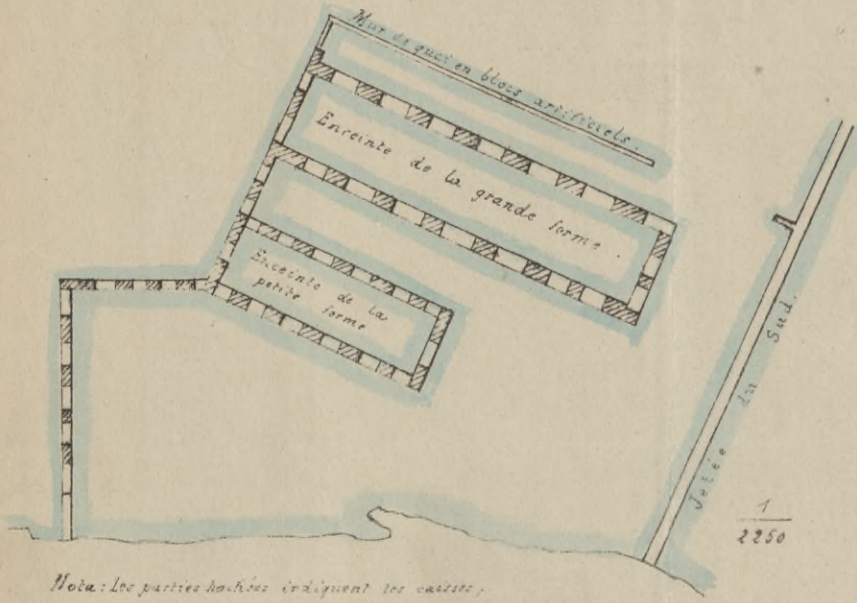



Fig. 276.

Bassins de radoub d'Alger.

Encintes des formes avant l'exécution des remblais.



Nota: Les parties hachées indiquent les caissons.

Coupe transversale.

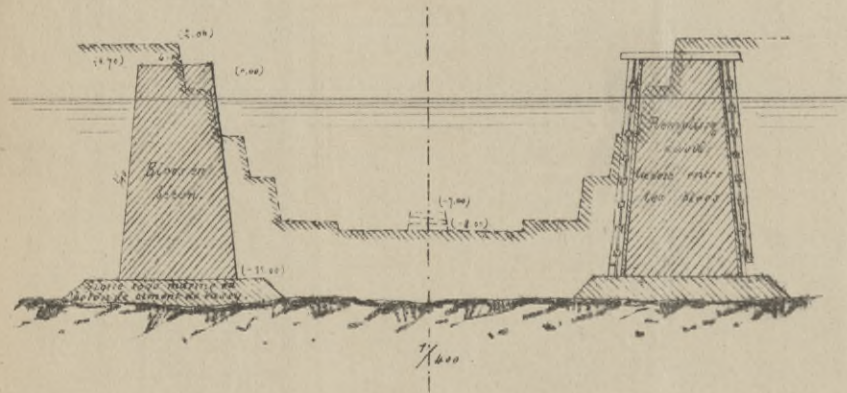

Fig. 277.

Forme de Portsmouth.

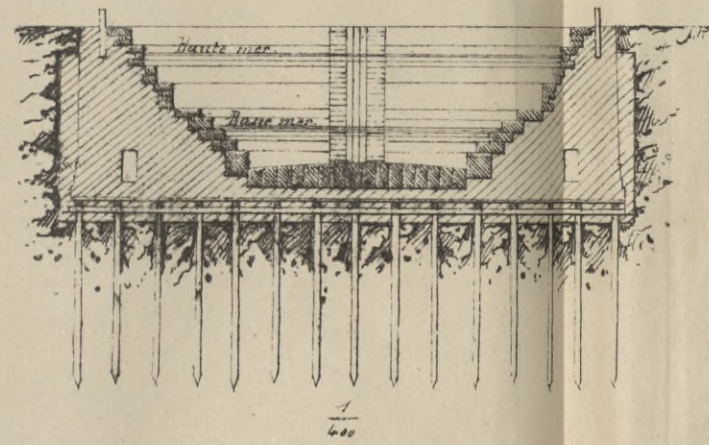

Fig. 280.

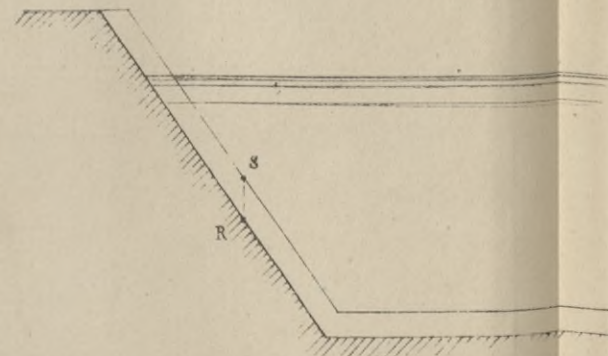

Fig. 278.

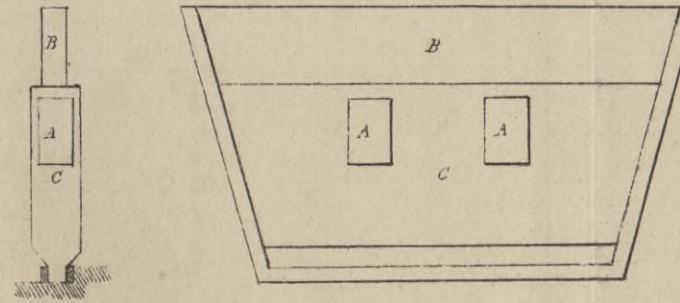

Fig. 281.

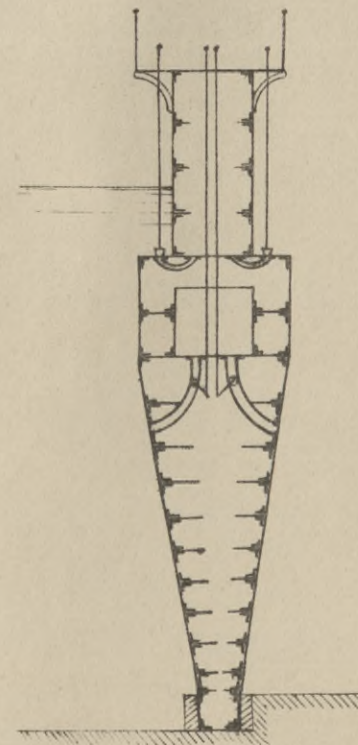

Fig. 279.

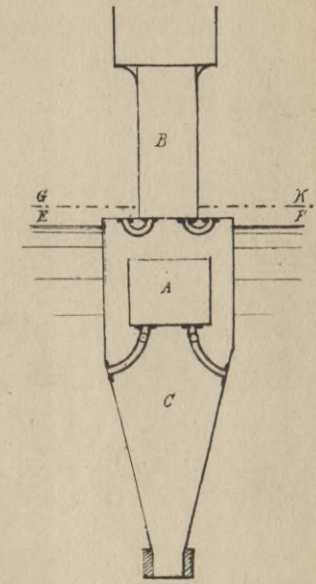

Fig. 282.

Bateau-porte système Choisy.

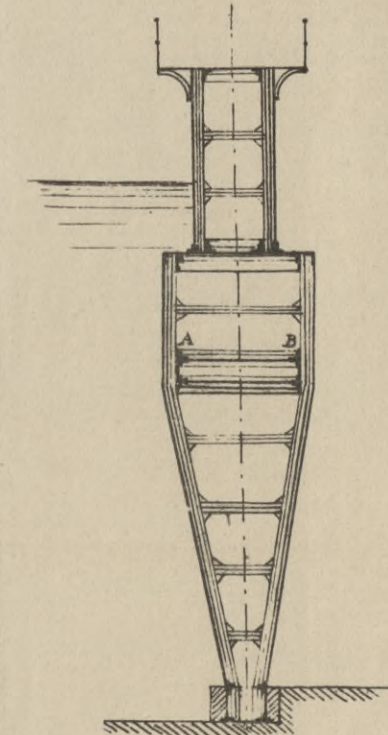







Fig. 283. Bateau-porte N°1 des bassins de radoub de Marseille.

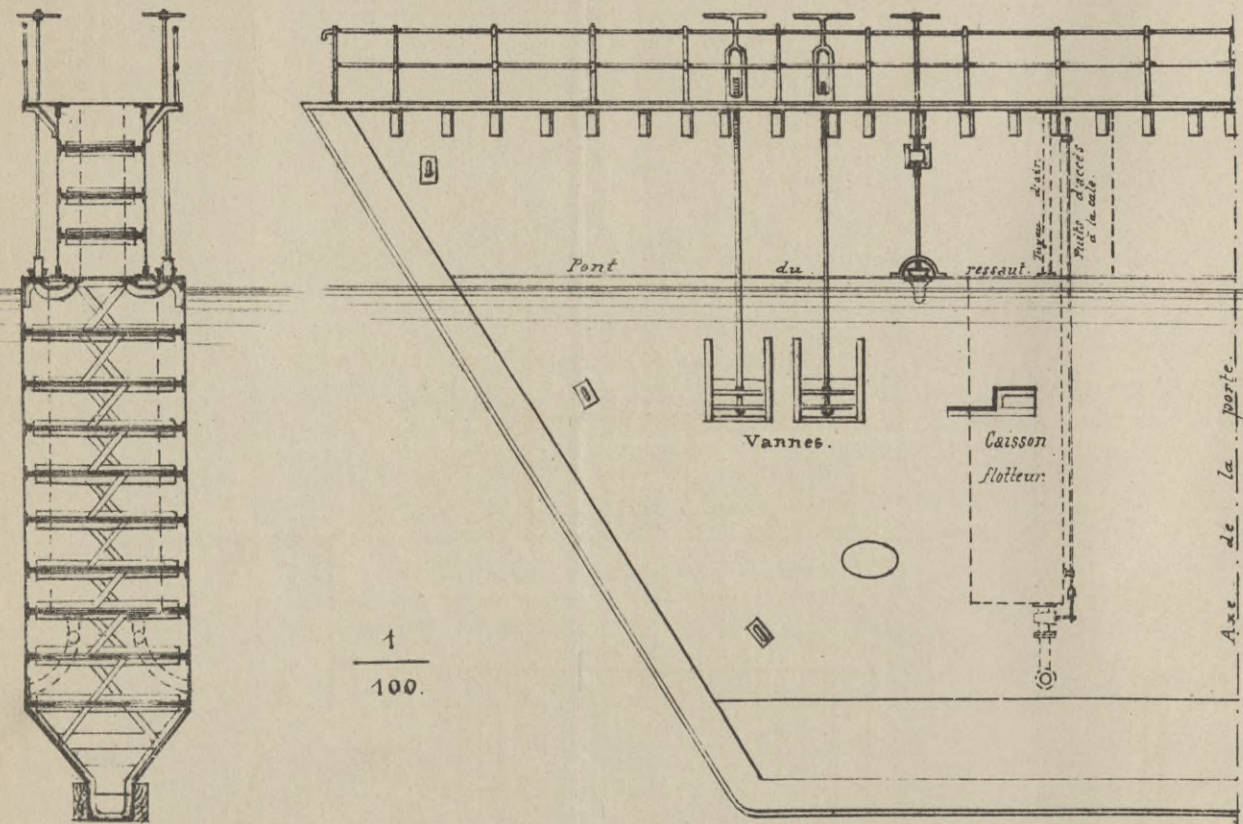

Fig. 284.

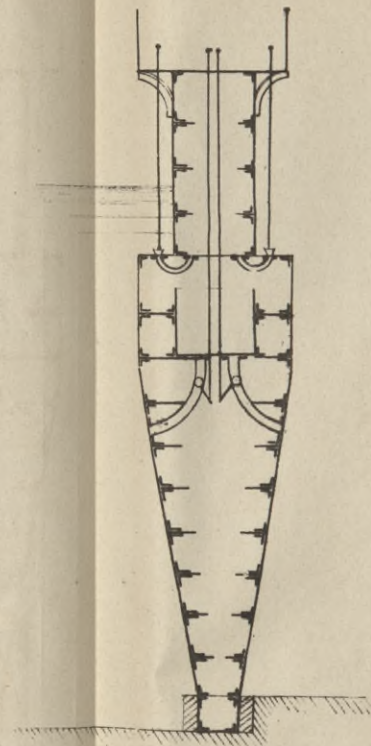

Fig. 285.

Porte roulante de la forme de radoub de Malte.

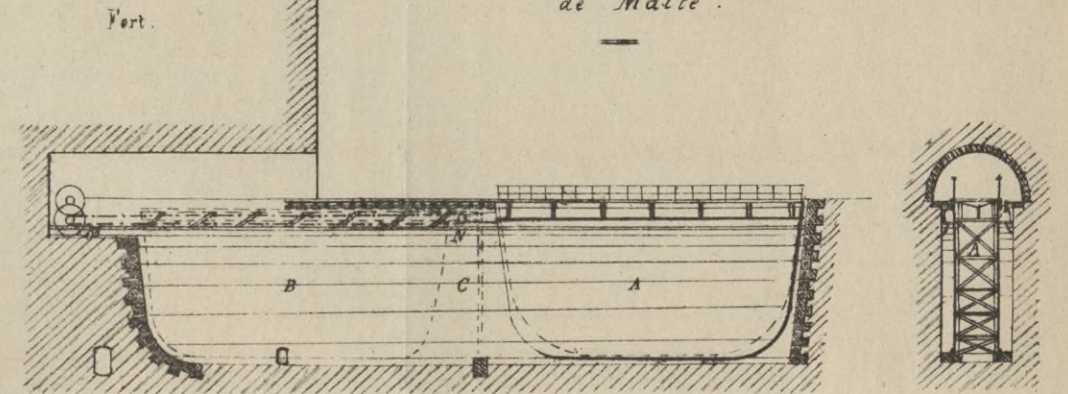

Fig. 287. Machine d'épuisement des bassins de radoub de Suez.

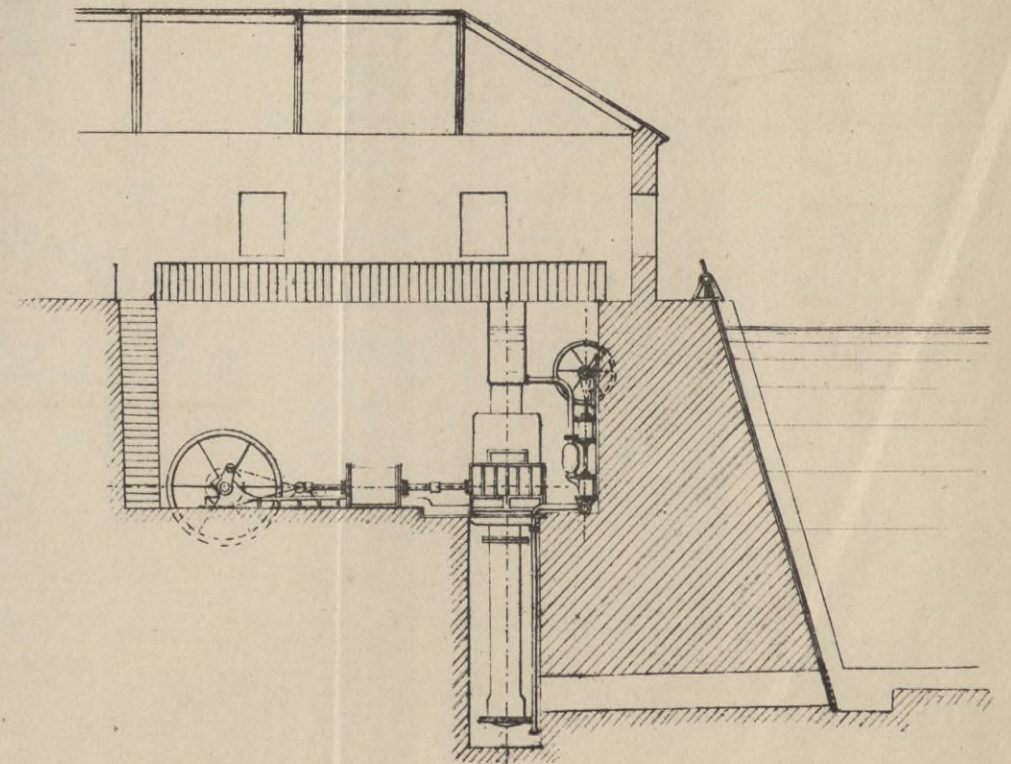

Fig. 286.

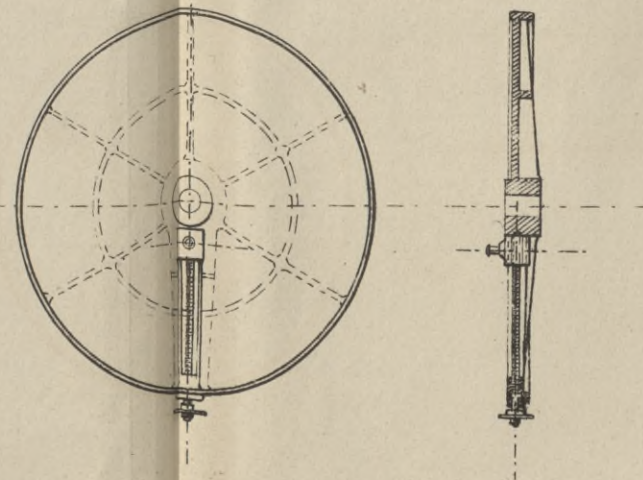





Fig 288. Machine d'épuisement des bassins le radoub de Marseille

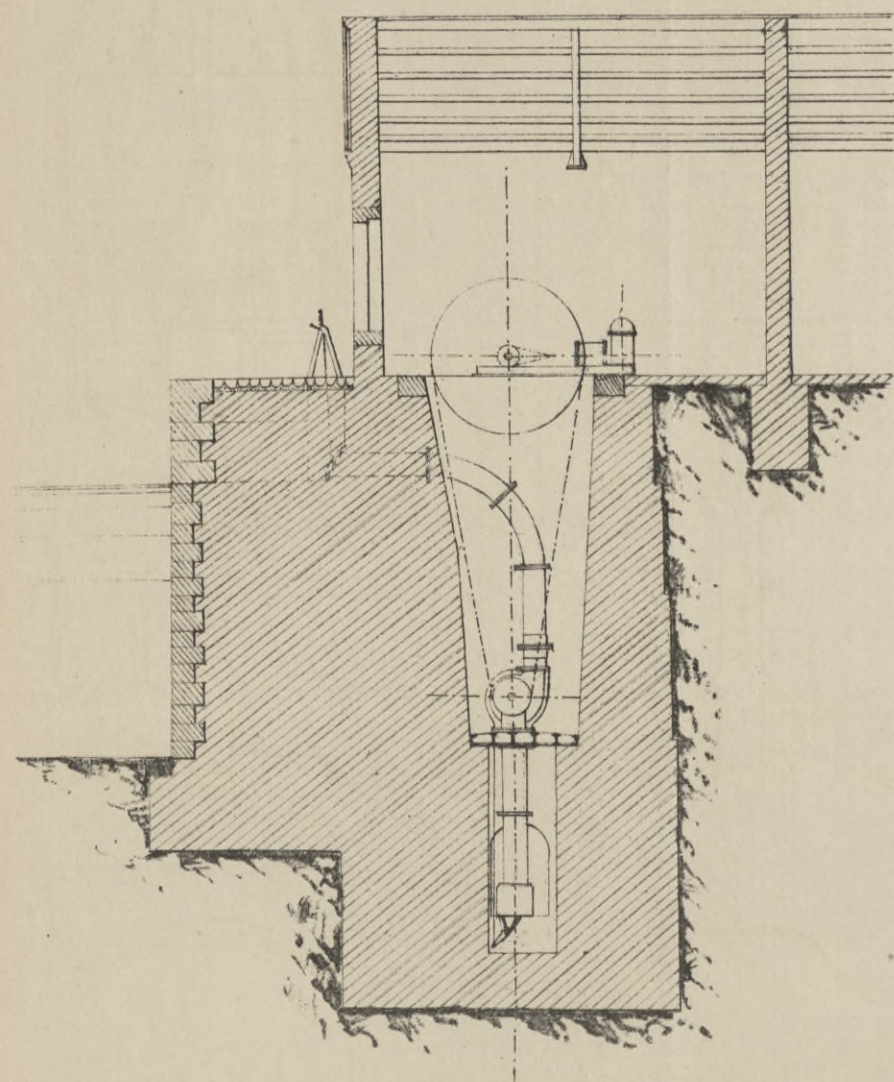

Fig. 289.

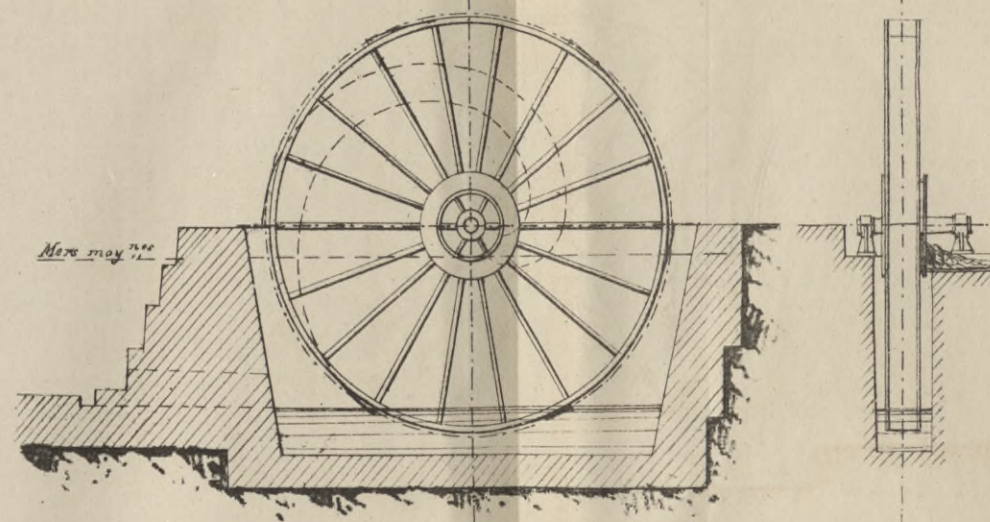

Fig. 291. Feu à éclipses.

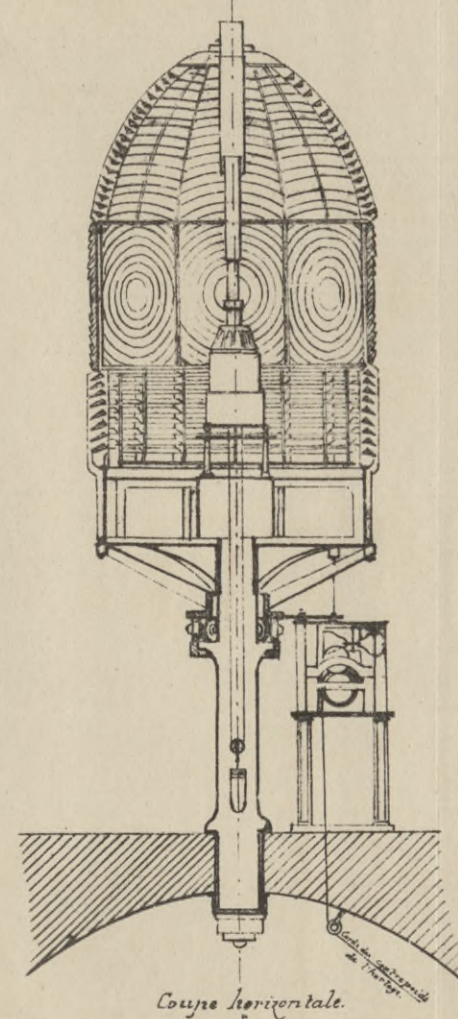

Fig. 292. Feu fixe.

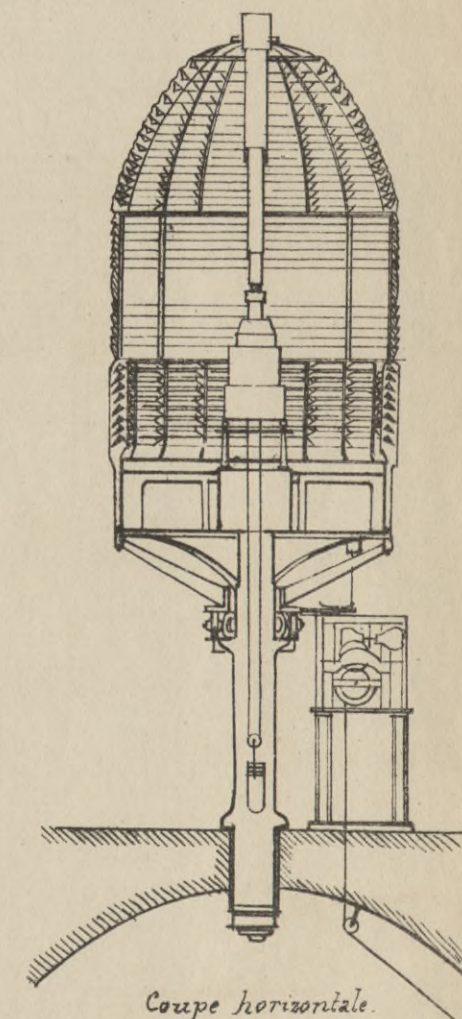
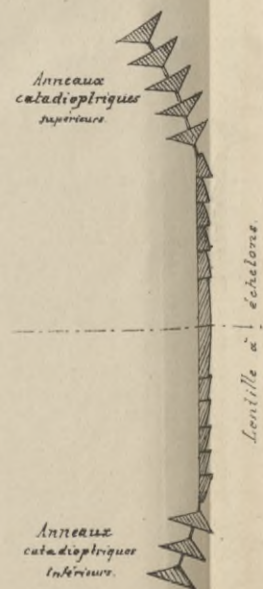
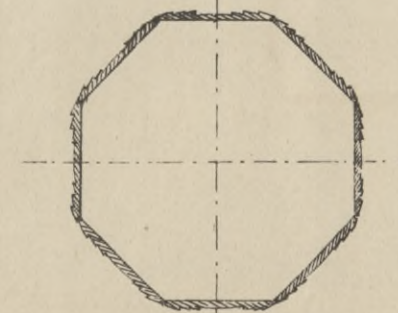

Fig. 290.



Coupe horizontale.



Coupe horizontale.

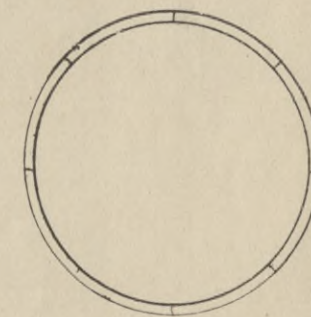



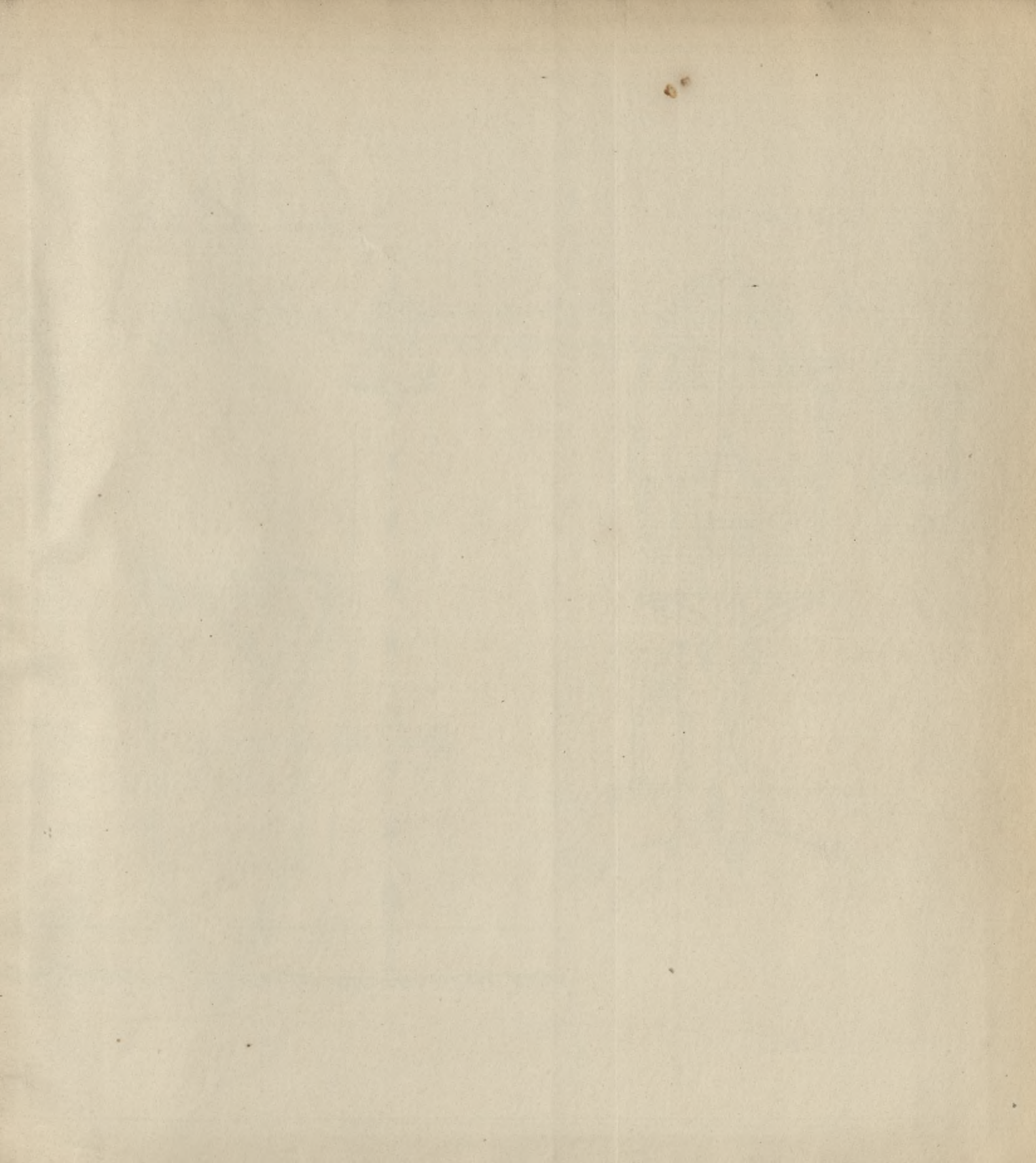

Fig. 293. Feu fixe varié par des éclats.

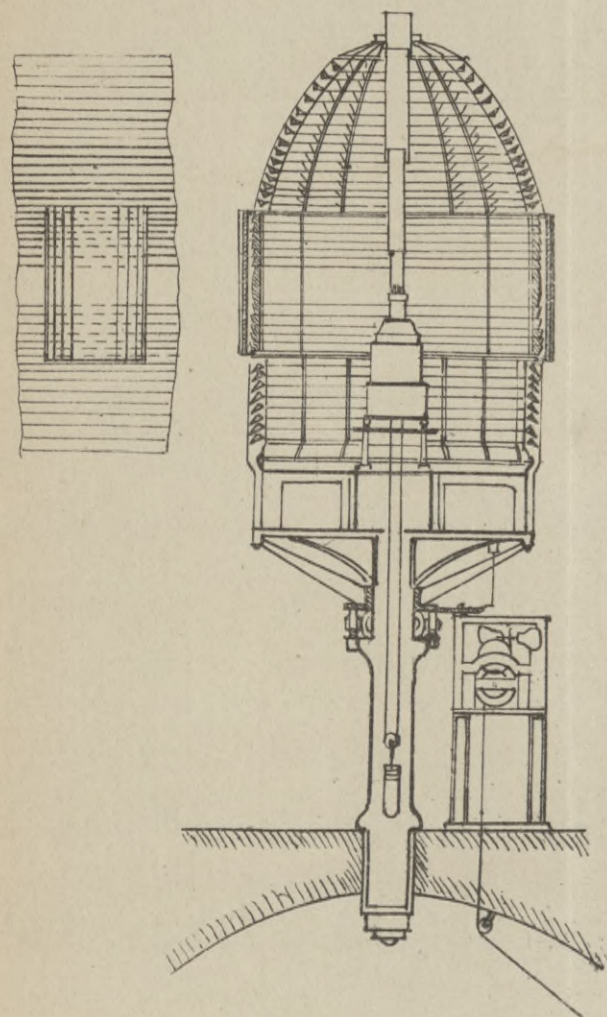

Fig. 294. Phare de Bréhat.

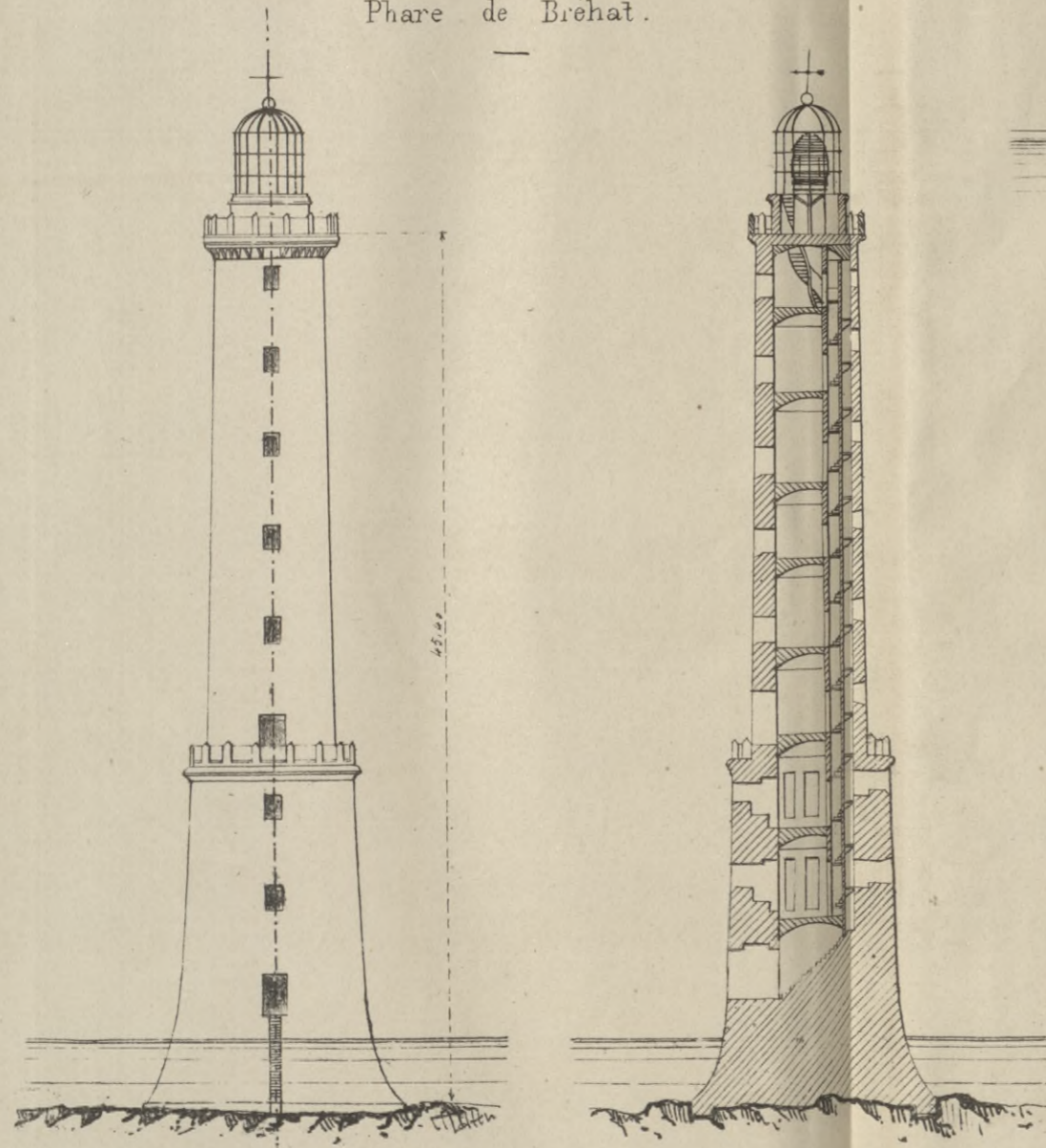

Fig. 295. Phare des Grandes Basses. (Ceglan.) (Débarquement des matériaux.)

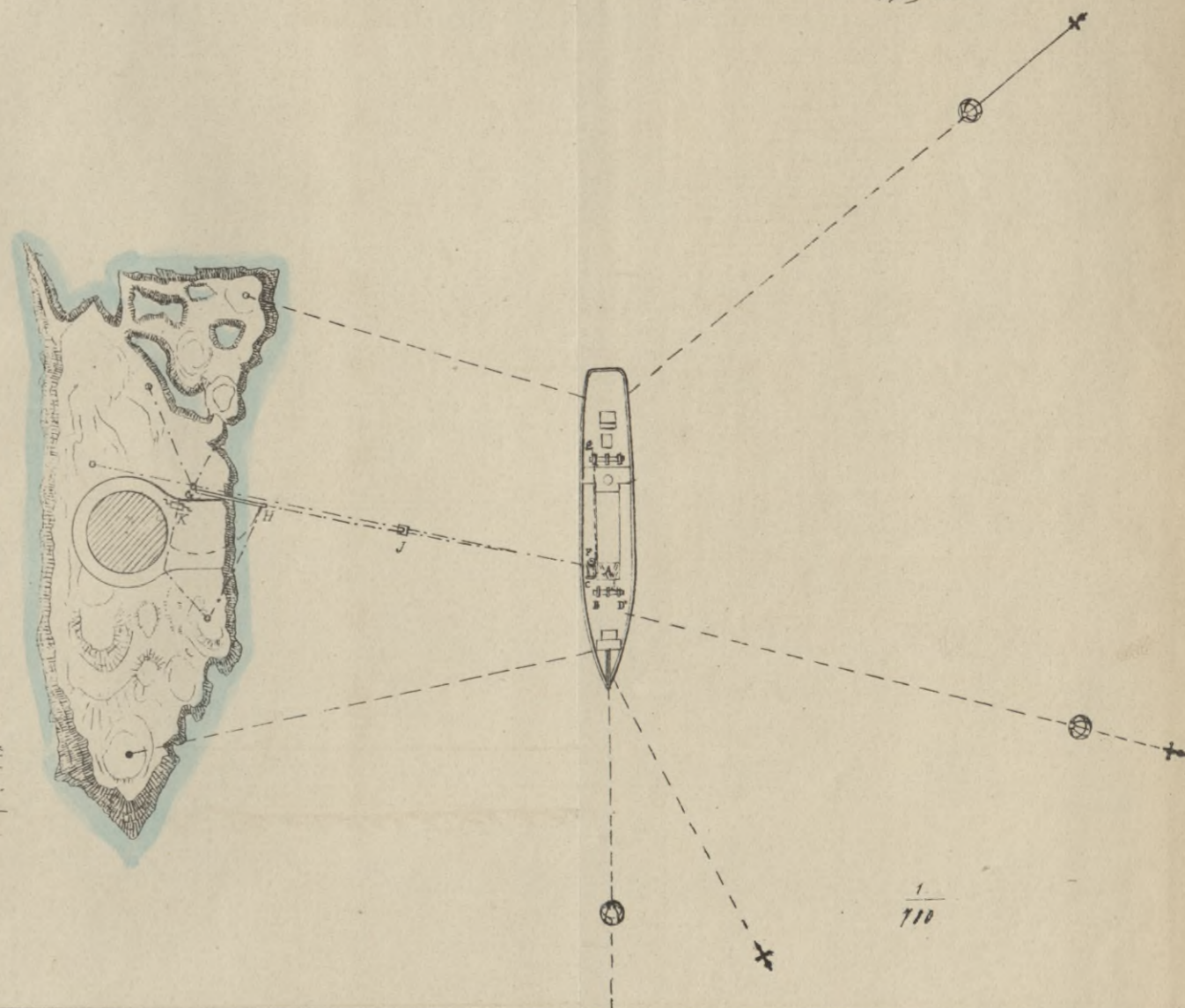
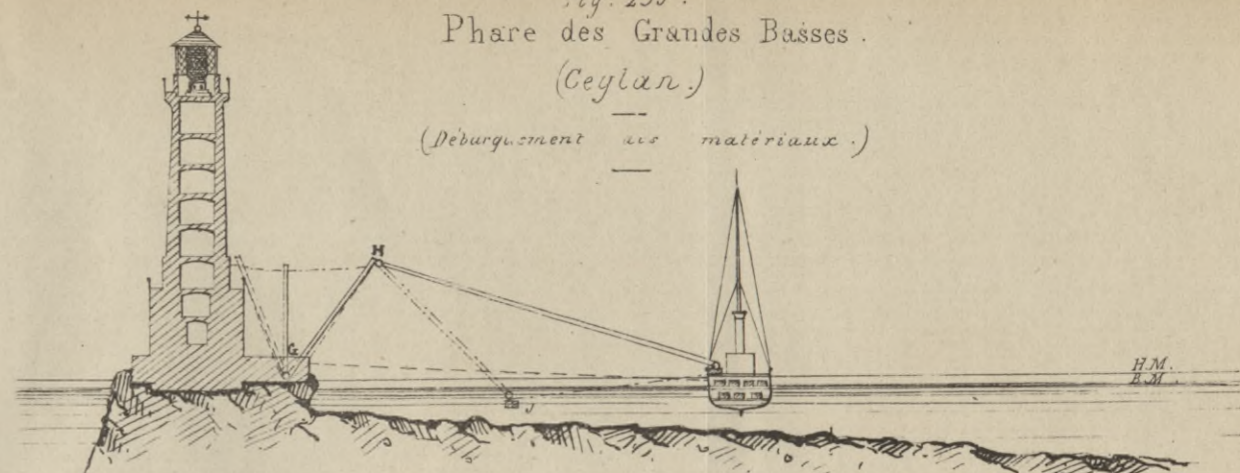







Fig 296.

Phare de Walde.

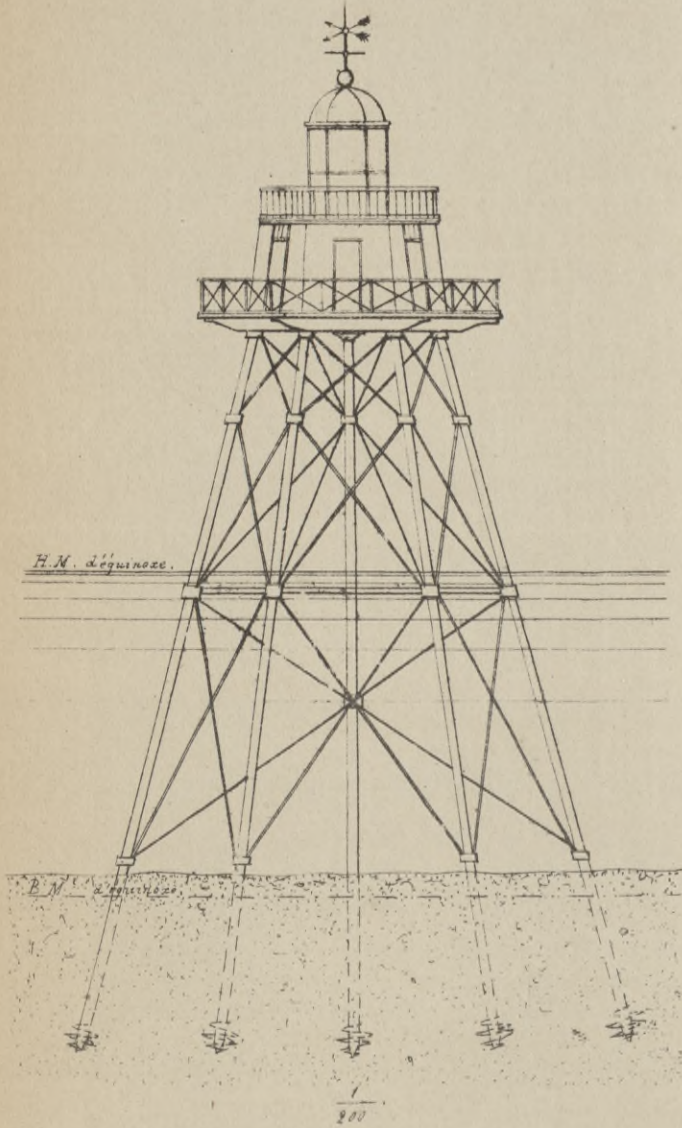

Fig 297. Phare de la Nouvelle Calédonie.

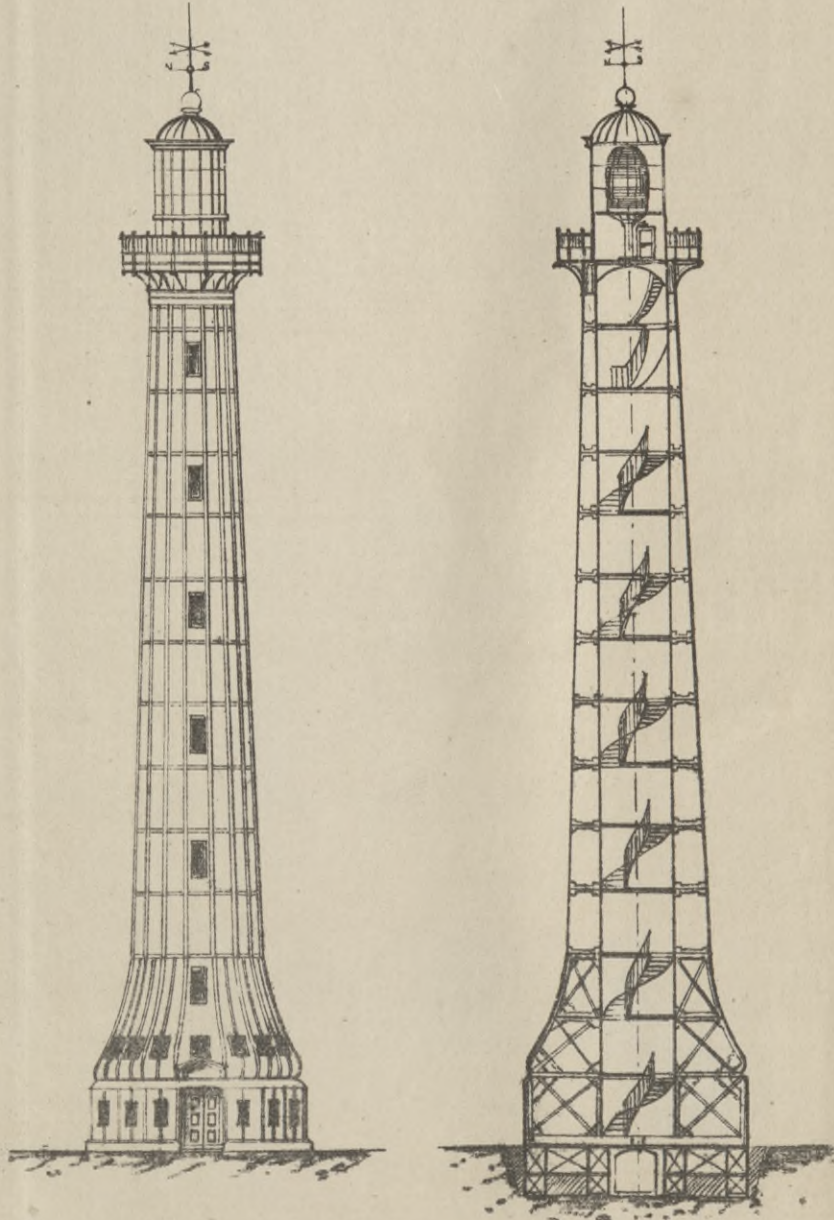

Fig 298. Phares de la Côte d'Égypte.

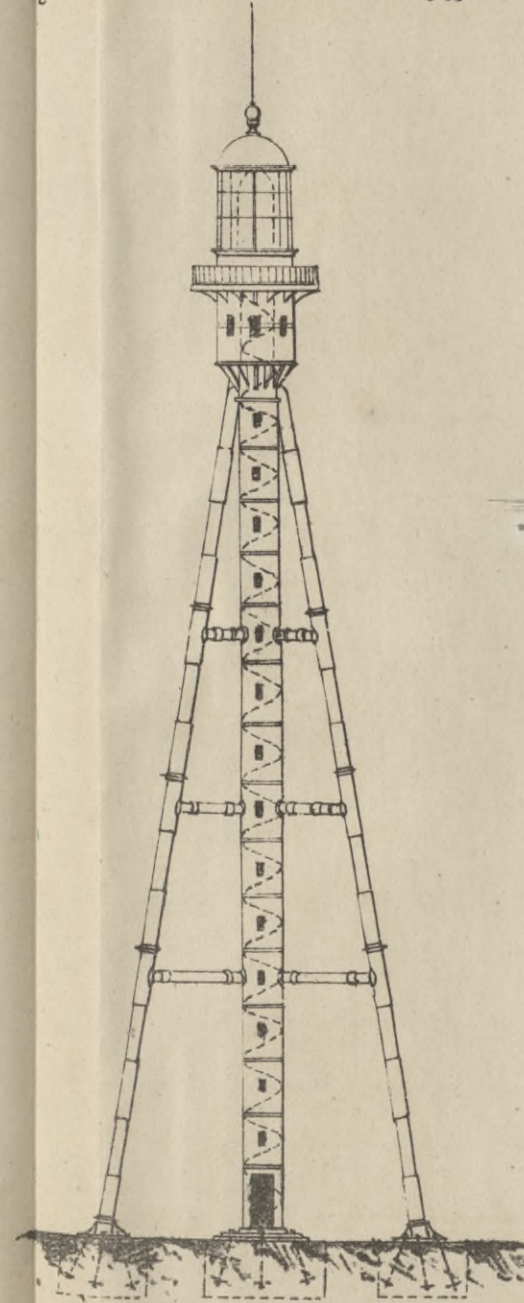

Fig 299.  
Phare flottant.

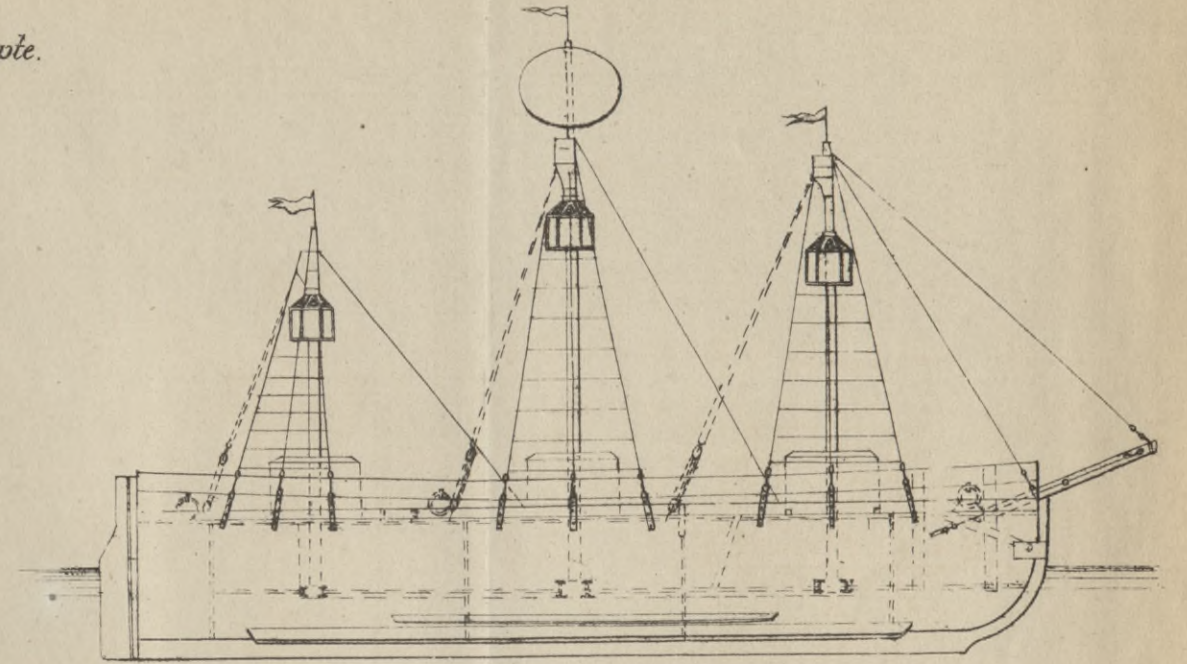
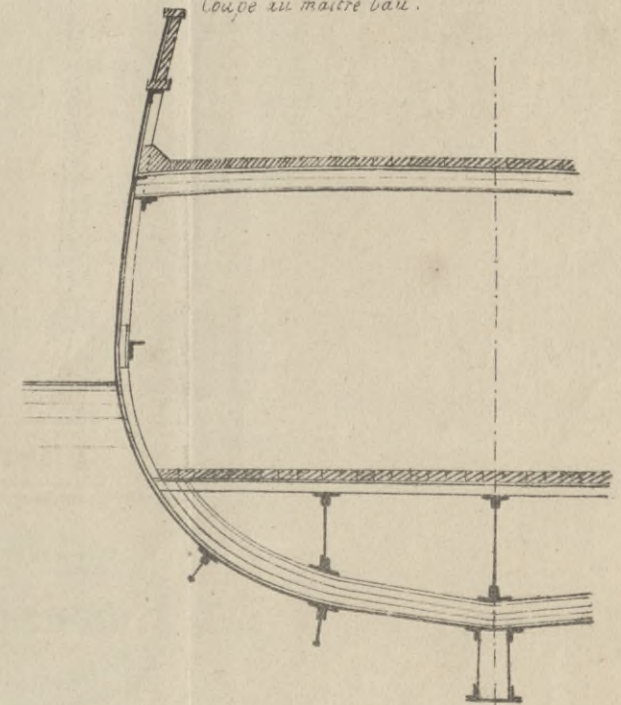

Fig 300.  
Phare flottant.  
Coupe au maître bau.





S. 61

# Avant - projet d'aménagement du port de Gênes.

Echelle de 1/4000



Coupe AB.  
Coupe transversale d'un môle affecté  
au service des marchandises générales.

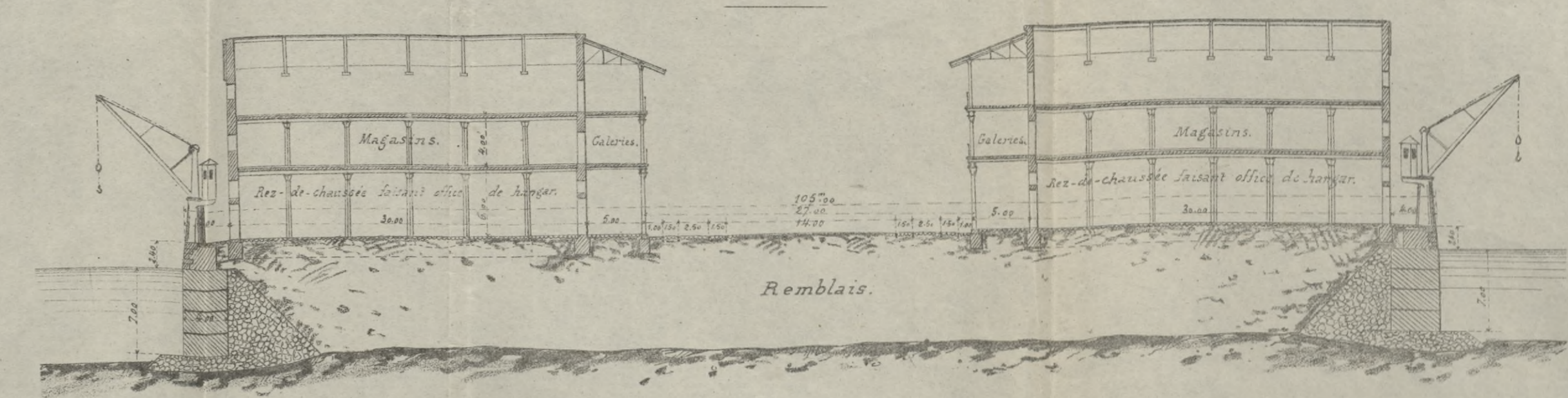

Coupe CD.  
Coupe transversale d'un môle affecté  
au service des marchandises lourdes et  
encombrantes.

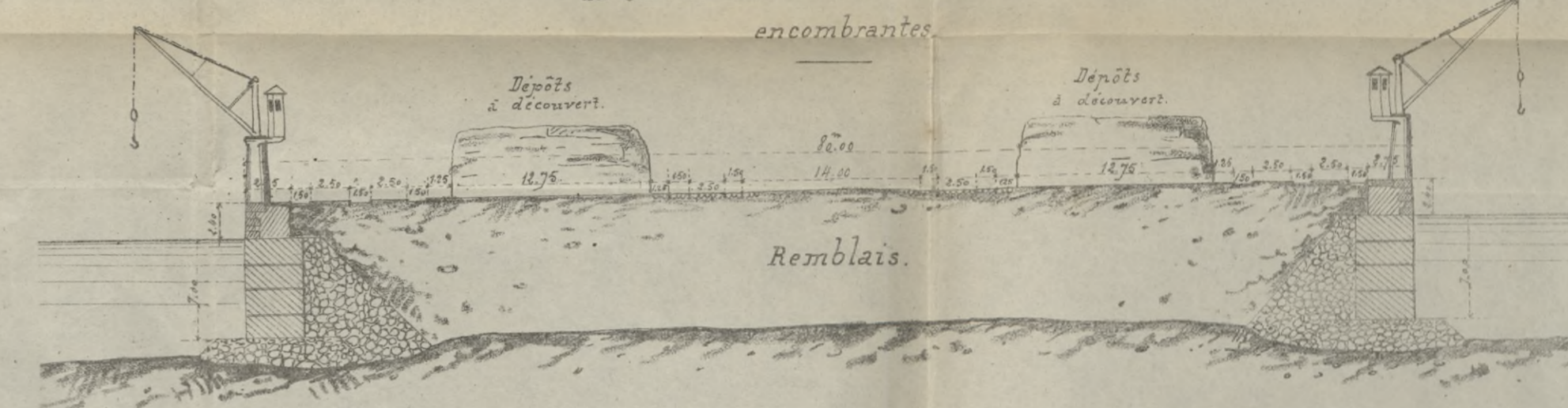

Coupe MN.  
Coupe transversale du quai de rive.

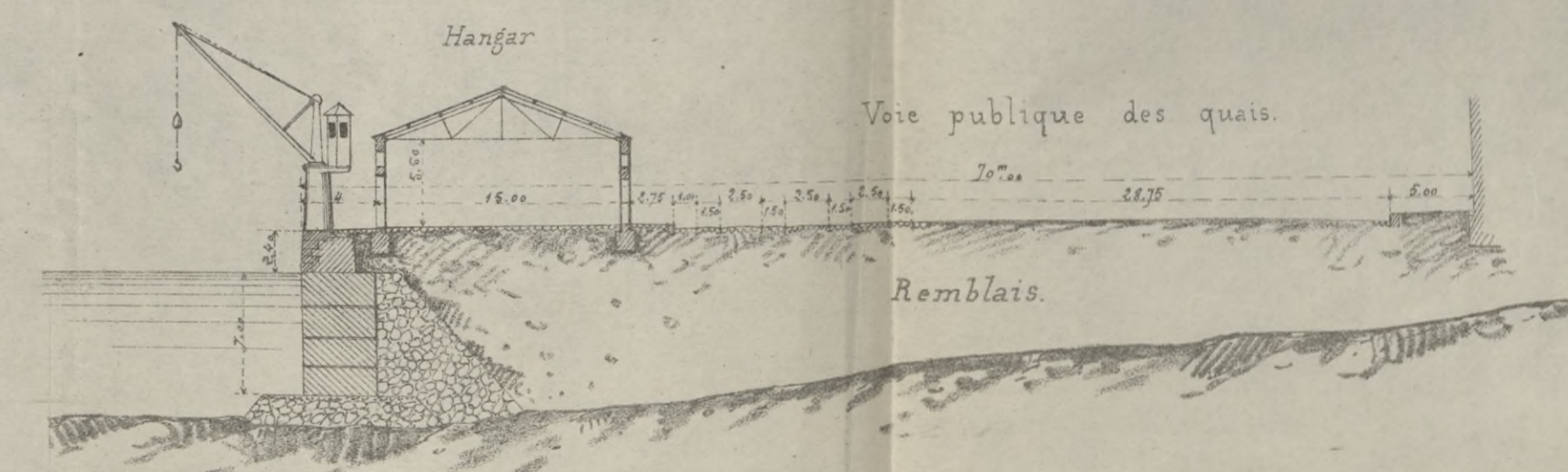

Coupe transversale  
de la  
digue extérieure

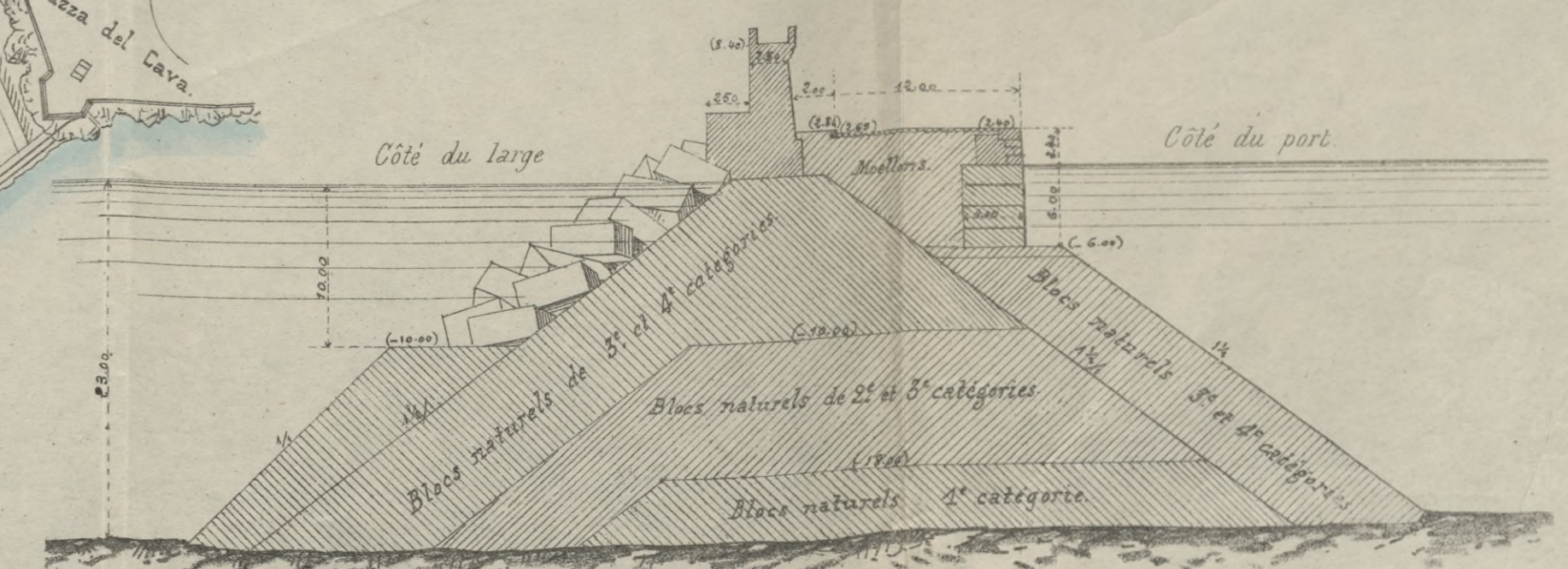

Echelle de 0,005 par mètre

Nota.—Le canal qui met en communication  
l'ancien port avec le nouveau, a pour  
but d'assainir la partie Est du premier.

# Avant - projet d'aménagement du port de Gênes.

Echelle de 1/4000

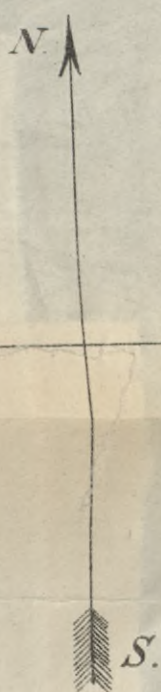

Avant - port.

Nouveau port.

Nota. - Le canal qui met en communication l'ancien port avec le nouveau, a pour but d'assainir la partie Est du premier.



Coupe AB.

Coupe transversale d'un môle affecté au service des marchandises générales.

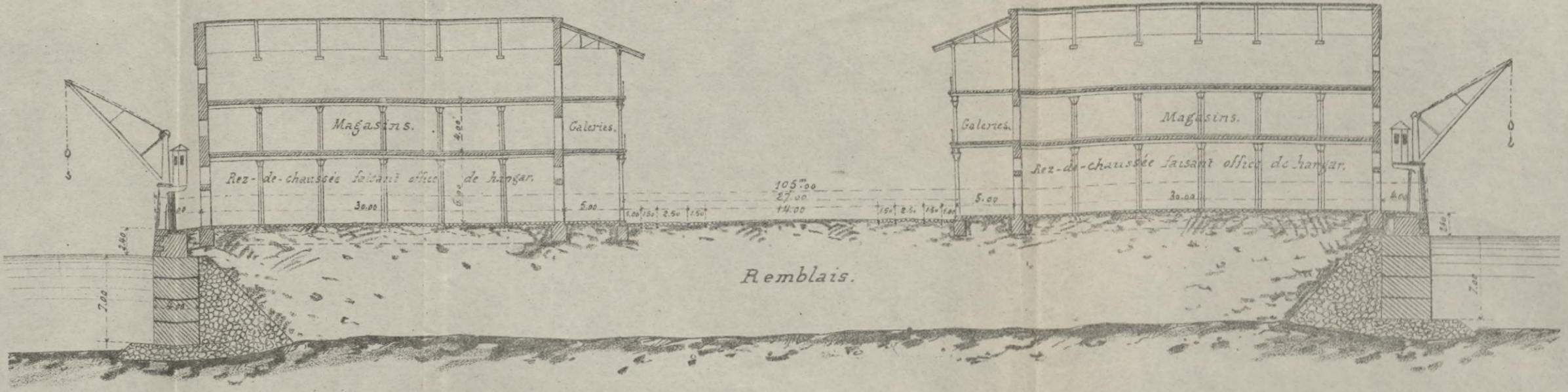

Coupe CD.

Coupe transversale d'un môle affecté au service des marchandises lourdes et encombrantes.

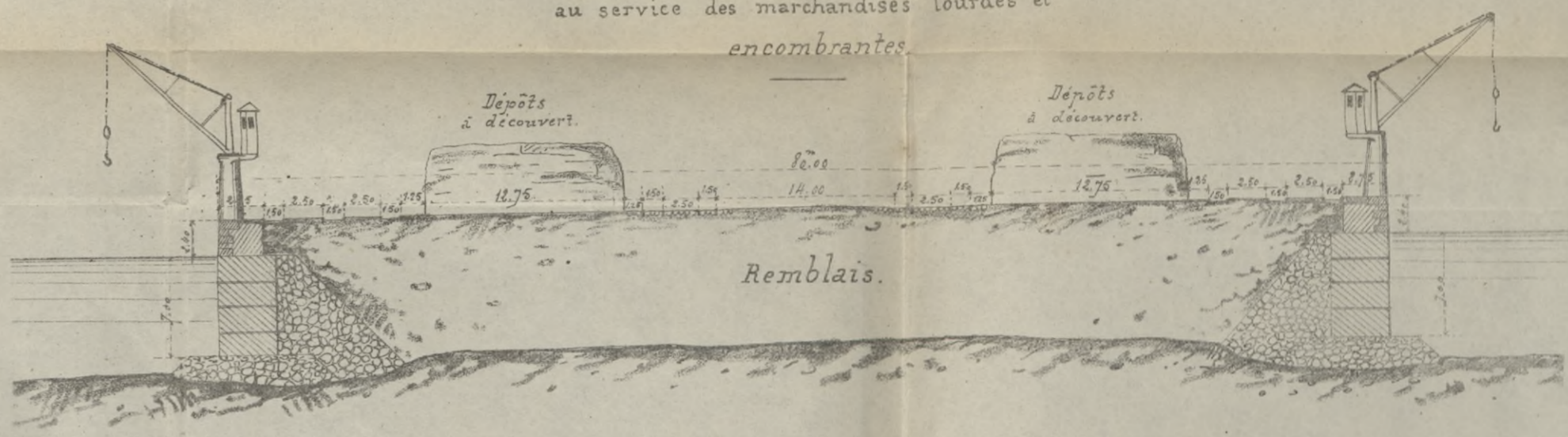

Coupe MN.

Coupe transversale du quai de rive.

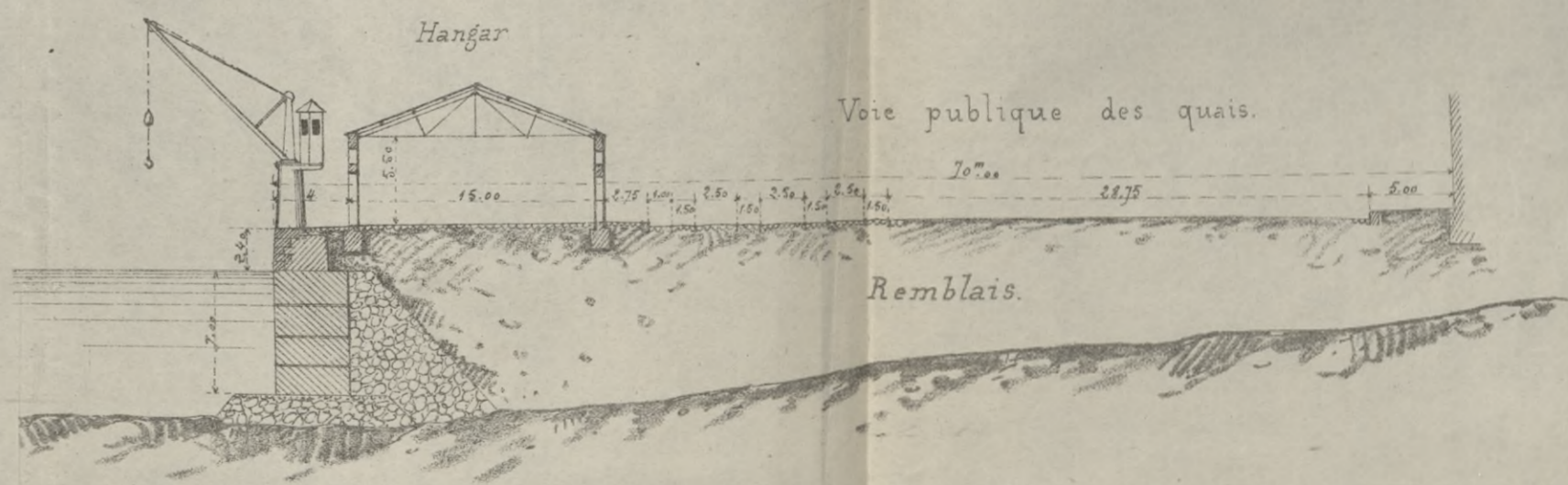

Coupe transversale de la digue extérieure

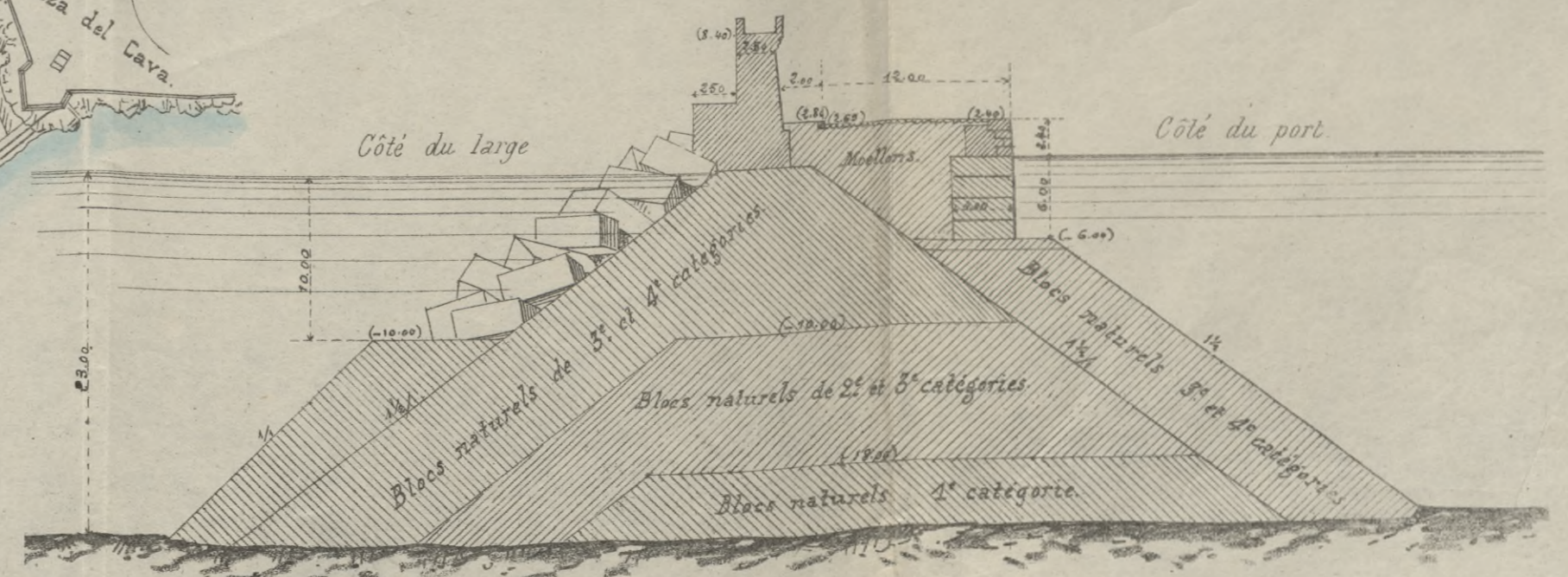

Échelle de 0.0025 par mètre

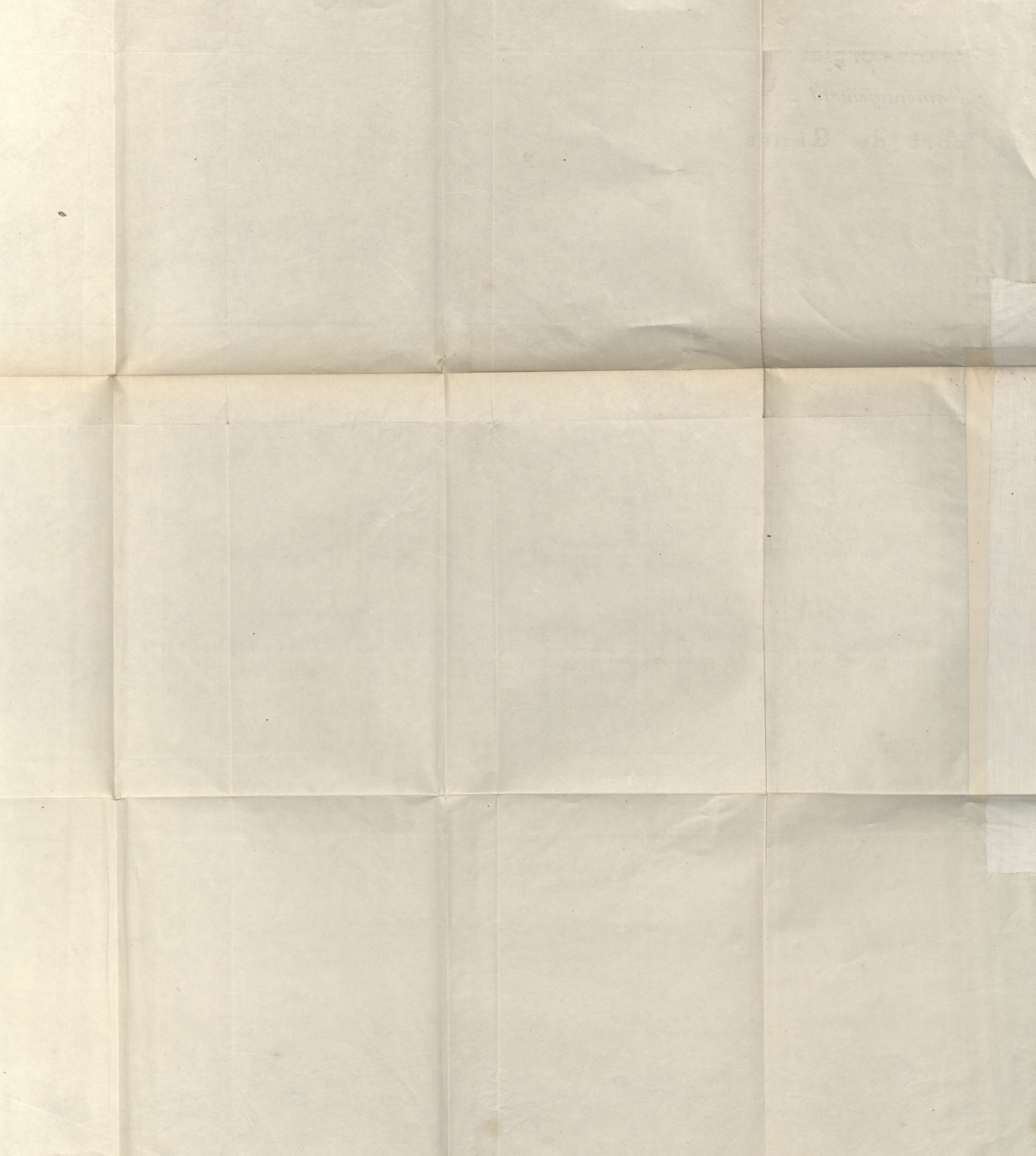

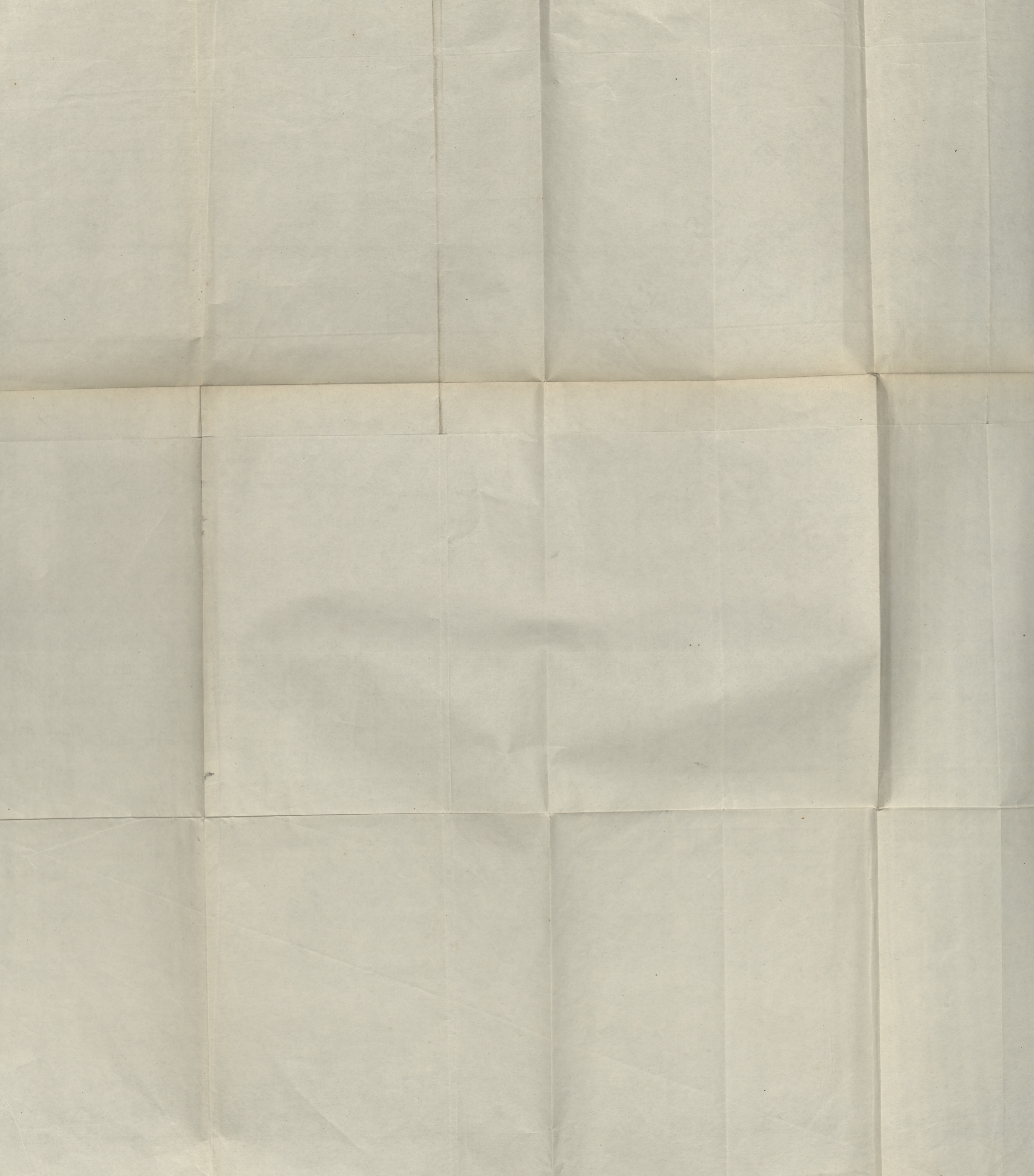









WYDZIAŁY POLITECHNICZNE KRA

BIBLIOTEKA GŁÓWNA



8182

L. inv.

Druk. U. J. Zam. 356. 10.000.

Biblioteka Politechniki Krakowskiej

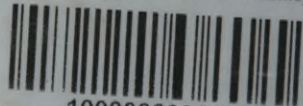

10000299663