

WYDZIAŁY POLITECHNICZNE KRAKÓW

BIBLIOTEKA GŁÓWNA

II

L. inw.

4730

Biblioteka Politechniki Krakowskiej



10000298996

16 JUN 1943

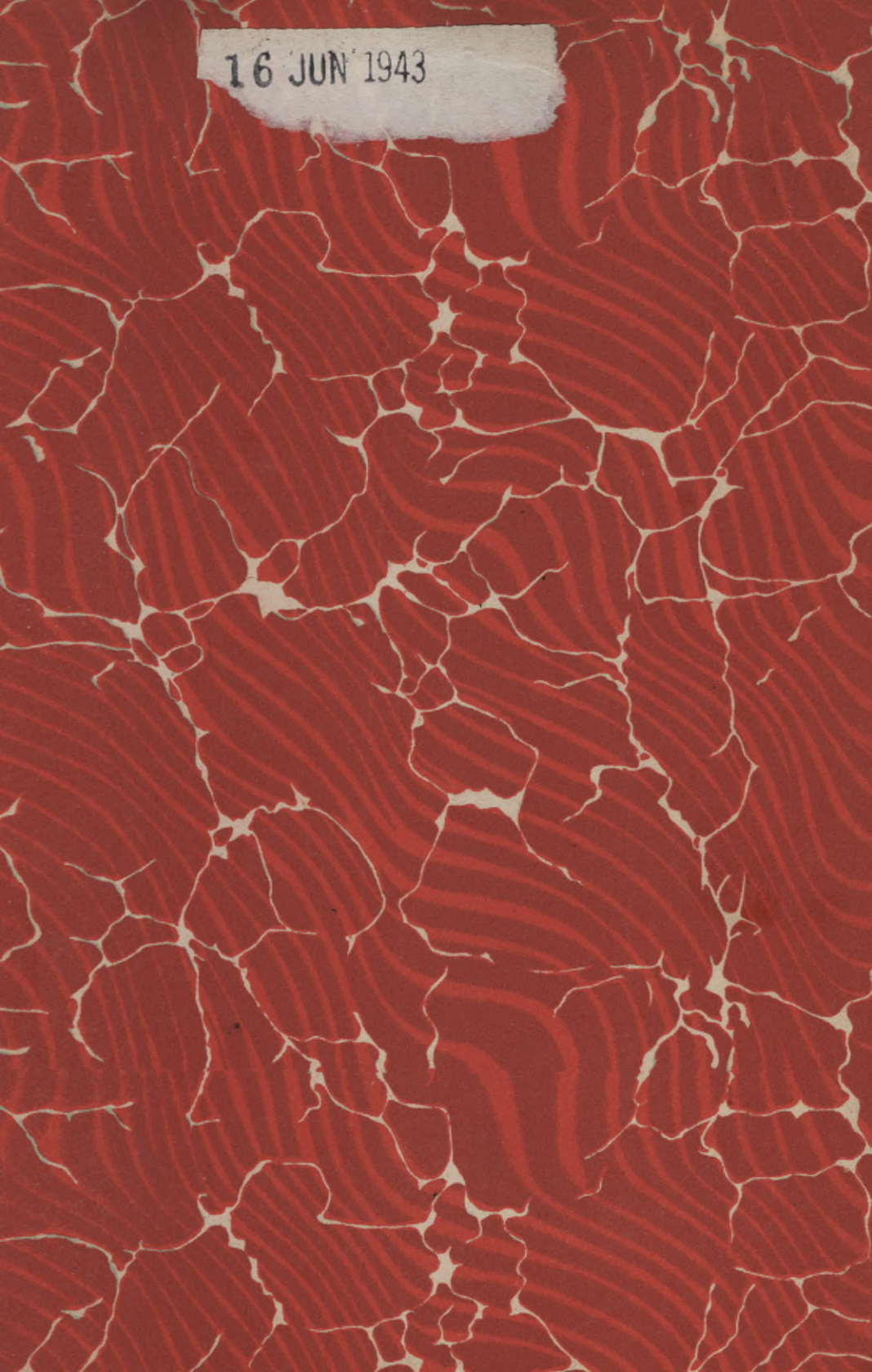
The background of the entire page is a marbled paper pattern. It consists of irregular, organic shapes in a deep red color, separated by thin, white, vein-like lines. The overall effect is a dense, textured, and somewhat abstract design.

Gift of The People of the United States  
Through the Victory Book Campaign  
(A. L. A. — A. R. C. — U. S. O.)  
To the Armed Forces and Merchant Marine

RHODE ISLAND STATE LIBRARY  
EXTENSION SERVICE

Vol. 2



D/592

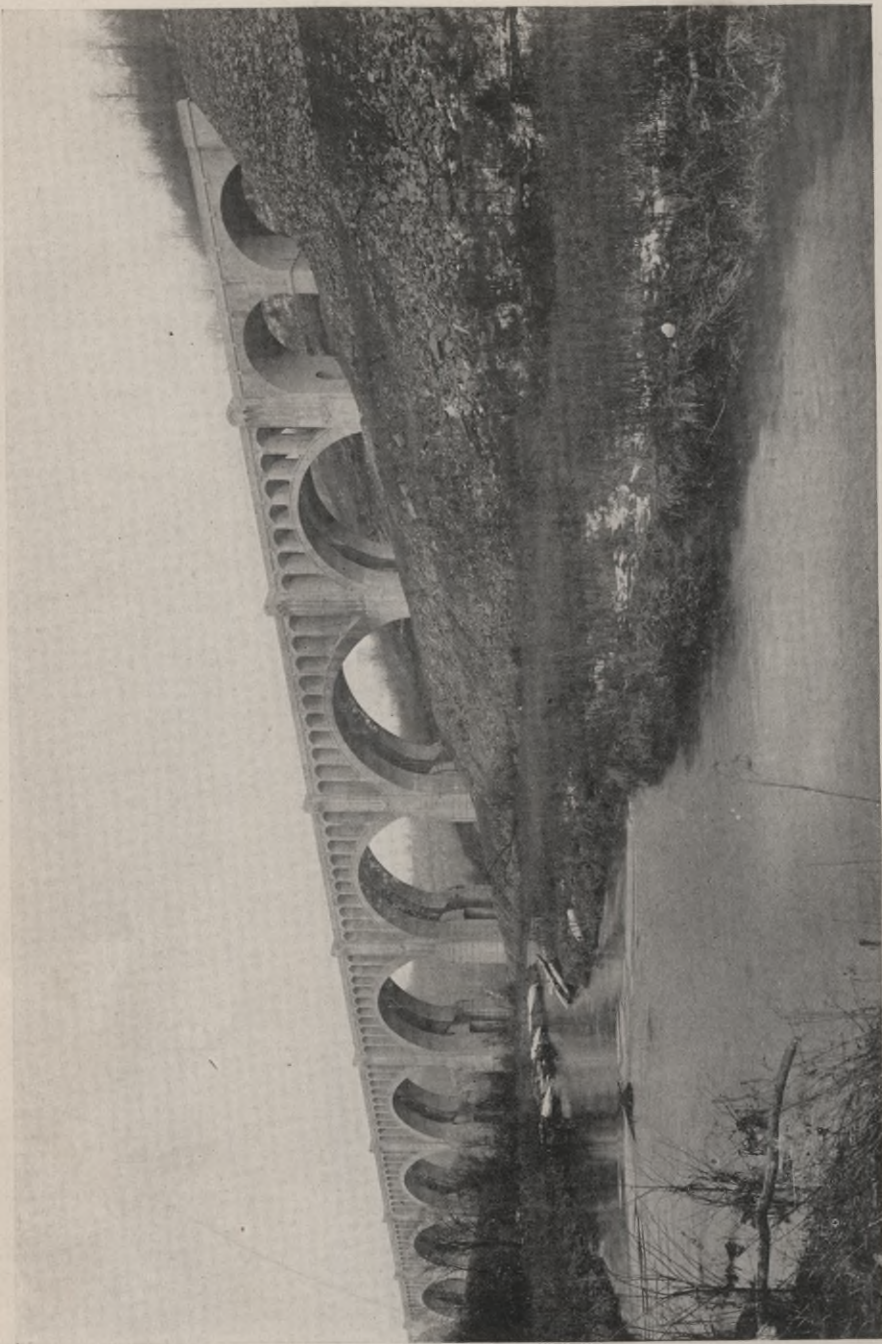

**MARTIN'S CREEK VIADUCT ON THE DELAWARE, LACKAWANNA AND WESTERN RAILROAD**

This is an excellent example of modern reinforced concrete construction in railroad work.

*Courtesy of Engineering Department, Delaware, Lackawanna and Western Railroad*

# Cyclopedia of Civil Engineering

*A General Reference Work on*

SURVEYING, HIGHWAY CONSTRUCTION, RAILROAD ENGINEERING, EARTHWORK,  
STEEL CONSTRUCTION, SPECIFICATIONS, CONTRACTS, BRIDGE ENGINEERING,  
MASONRY AND REINFORCED CONCRETE, MUNICIPAL ENGINEERING,  
HYDRAULIC ENGINEERING, RIVER AND HARBOR IMPROVEMENT,  
IRRIGATION ENGINEERING, COST ANALYSIS, ETC.

*Prepared by a Corps of*

CIVIL AND CONSULTING ENGINEERS AND TECHNICAL EXPERTS OF THE  
HIGHEST PROFESSIONAL STANDING

*Illustrated with over Two Thousand Engravings*

NINE VOLUMES

CHICAGO  
AMERICAN TECHNICAL SOCIETY  
1917

SAMP ENDICOTT LIBRARY  
DAVISVILLE, R.I.

DAR  
RADY POLONII  
AMERYKAŃSKIEJ

D/592



24388

COPYRIGHT, 1908, 1909, 1915, 1916  
BY  
AMERICAN TECHNICAL SOCIETY

COPYRIGHT, 1908, 1909, 1915, 1916  
BY  
AMERICAN SCHOOL OF CORRESPONDENCE

Copyrighted in Great Britain  
All Rights Reserved



DAVISVILLE, R. I.  
GANN EXHIBIT LIBRARY

II 4730

Akc. Nr. 3475/60



## Authors and Collaborators

---

### FREDERICK E. TURNEAURE, C. E., Dr. Eng.

Dean of the College of Engineering, and Professor of Engineering, University of Wisconsin  
Member, American Society of Civil Engineers  
Joint Author of "Principles of Reinforced Concrete Construction," "Public Water Supplies," etc.

### FRANK O. DUFOUR, C. E.

Structural Engineer with Interstate Commerce Commission Division of Valuation, Central District  
Formerly Assistant Professor of Structural Engineering, University of Illinois  
Member, American Society of Civil Engineers  
Member, American Society for Testing Materials

### WALTER LORING WEBB, C. E.

Consulting Civil Engineer  
Member, American Society of Civil Engineers  
Author of "Railroad Construction," "Economics of Railroad Construction," etc.

### W. G. BLIGH

Inspecting Engineer of Irrigation Works, Department of Interior, Canada  
Formerly in Engineering Service of His Majesty in India  
Member, Institute Civil Engineers (London)  
Member, American Society of Civil Engineers  
Member, Canadian Society of Civil Engineers

### ADOLPH BLACK, C. E.

Civil and Sanitary Engineer, General Chemical Company, New York City  
Formerly Adjunct Professor of Civil Engineering, Columbia University

### EDWARD R. MAURER, B. C. E.

Professor of Mechanics, University of Wisconsin  
Joint Author of "Principles of Reinforced Concrete Construction"

### AUSTIN T. BYRNE

Civil Engineer  
Author of "Highway Construction," "Materials and Workmanship"

## Authors and Collaborators—Continued

### A. MARSTON, C. E.

Dean of Division of Engineering and Professor of Civil Engineering, Iowa State College  
Member, American Society of Civil Engineers  
Member, Western Society of Civil Engineers

### De WITT V. MOORE

Consulting Engineer and Architect  
District Engineer—Central District Division of Valuation  
Interstate Commerce Commission, Chicago  
Member, American Society Engineering Contractors  
Member, Indiana Engineering Society

### W. HERBERT GIBSON, B. S., C. E.

Civil Engineer  
Designer of Reinforced Concrete

### C. D. RAWSTORNE, C. E.

Consulting Engineer, Civil Engineering Department, American School of Correspondence  
Formerly Superintendent of Construction, John M. Ewen Company

### HENRY J. BURT, B. S., C. E.

Structural Engineer for Holabird and Roche, Architects  
Member, American Society of Civil Engineers  
Member, Western Society of Civil Engineers  
Member, Society for the Promotion of Engineering Education

### RICHARD I. D. ASHBRIDGE

Civil Engineer  
Member, American Society of Civil Engineers

### HERMAN K. HIGGINS

Civil Engineer  
Associate Member, American Society of Civil Engineers  
Member, Boston Society of Civil Engineers  
Member, New England Water Works Association  
Member, American Railway Bridge and Building Association

### ALFRED E. PHILLIPS, C. E., Ph. D.

Professor of Civil Engineering, Armour Institute of Technology

## Authors and Collaborators—Continued

---

H. E. MURDOCK, M. E., C. E.

Head of Department of Agricultural Engineering, Montana State College, Bozeman,  
Montana  
Formerly Irrigation Engineer, U. S. Department of Agriculture

A. B. McDANIEL, B. S.

Assistant Professor of Civil Engineering, University of Illinois  
Member, American Society of Civil Engineers  
Member, Society for the Promotion of Engineering Education  
Fellow, Association for the Advancement of Science  
Author of "Excavating Machinery"

GLENN M. HOBBS, Ph. D.

Secretary and Educational Director, American School of Correspondence  
Formerly Instructor, Department of Physics, University of Chicago  
American Physical Society

THOMAS FLEMING, Jr., B. S., C. E.

With Chester & Fleming, Hydraulic and Sanitary Engineers  
Associate Member, American Society of Civil Engineers  
Member, New England Water Works Association  
Member, Engineers' Society of Pennsylvania

CHARLES E. MORRISON, C. E., Ph. D.

Formerly Instructor in Civil Engineering, Columbia University  
Associate Member, American Society of Civil Engineers  
Author of "Highway Engineering", "High Masonry Dam Design"

EDWARD B. WAITE

Formerly Dean, and Head, Consulting Department, American School of Correspondence  
American Society of Mechanical Engineers  
Boston Society of Civil Engineers

HAROLD W. ROBBINS, M. E.

Formerly Instructor, Lewis Institute, and Armour Institute, Chicago  
Past Secretary, The Aero Club of Illinois  
Special Writer and Technical Investigator

JESSIE M. SHEPHERD, A. B.

Head, Publication Department, American Technical Society

## Authorities Consulted

---

THE editors have freely consulted the standard technical literature of America and Europe in the preparation of these volumes. They desire to express their indebtedness, particularly, to the following eminent authorities, whose well-known treatises should be in the library of everyone interested in Civil Engineering.

Grateful acknowledgment is here made also for the invaluable cooperation of the foremost Civil, Structural, Railroad, Hydraulic, and Sanitary Engineers and Manufacturers in making these volumes thoroughly representative of the very best and latest practice in every branch of the broad field of Civil Engineering.

---

### WILLIAM G. RAYMOND, C. E.

Dean of the School of Applied Science and Professor of Civil Engineering in the State University of Iowa; American Society of Civil Engineers  
Author of "A Textbook of Plane Surveying," "The Elements of Railroad Engineering"

### JOSEPH P. FRIZELL

Hydraulic Engineer and Water-Power Expert; American Society of Civil Engineers  
Author of "Water Power, the Development and Application of the Energy of Flowing Water"

### FREDERICK E. TURNEAURE, C. E., Dr. Eng.

Dean of the College of Engineering and Professor of Engineering, University of Wisconsin  
Joint Author of "Public Water Supplies," "Theory and Practice of Modern Framed Structures," "Principles of Reinforced Concrete Construction"

### HENRY N. OGDEN, C. E.

Professor of Sanitary Engineering, Cornell University  
Author of "Sewer Design"

### DANIEL CARHART, C. E.

Emeritus Professor of Civil Engineering, University of Pittsburgh  
Author of "Treatise on Plane Surveying"

### HALBERT P. GILLETTE

Editor of *Engineering and Contracting*; American Society of Civil Engineers; Formerly Chief Engineer, Washington State Railroad Commission  
Author of "Handbook of Cost Data for Contractors and Engineers"

### CHARLES E. GREENE, A. M., C. E.

Late Professor of Civil Engineering, University of Michigan  
Author of "Trusses and Arches, Graphic Method," "Structural Mechanics"

## Authorities Consulted—Continued

### A. PRESCOTT FOLWELL

Editor of *Municipal Journal and Engineer*; Formerly Professor of Municipal Engineering, Lafayette College  
Author of "Water Supply Engineering," "Sewerage"

### IRVING P. CHURCH, C. E.

Professor of Applied Mechanics and Hydraulics, Cornell University  
Author of "Mechanics of Engineering"

### PAUL C. NUGENT, A. M., C. E.

Professor of Civil Engineering, Syracuse University  
Author of "Plane Surveying"

### FRANK W. SKINNER, C. E.

Consulting Engineer; Associate Editor of *The Engineering Record*  
Author of "Types and Details of Bridge Construction"

### HANBURY BROWN, K. C. M. G.

Member of the Institution of Civil Engineers  
Author of "Irrigation, Its Principles and Practice"

### SANFORD E. THOMPSON, S. B., C. E.

American Society of Civil Engineers  
Joint Author of "A Treatise on Concrete, Plain and Reinforced"

### JOSEPH KENDALL FREITAG, B. S., C. E.

American Society of Civil Engineers  
Author of "Architectural Engineering," "Fireproofing of Steel Buildings," "Fire Prevention and Fire Protection"

### AUSTIN T. BYRNE, C. E.

Civil Engineer  
Author of "Highway Construction," "Inspection of Materials and Workmanship Employed in Construction"

### JOHN F. HAYFORD, C. E.

Expert Computer and Geodesist, U. S. Coast and Geodetic Survey  
Author of "A Textbook of Geodetic Astronomy"

### WALTER LORING WEBB, C. E.

Consulting Civil Engineer; American Society of Civil Engineers  
Author of "Railroad Construction in Theory and Practice," "Economics of Railroad Construction," etc.

**Authorities Consulted—Continued**

---

**EDWARD R. MAURER, B. C. E.**

Professor of Mechanics, University of Wisconsin  
Joint Author of "Principles of Reinforced Concrete Construction"

**HERBERT M. WILSON, C. E.**

Geographer and Former Irrigation Engineer, United States Geological Survey; American Society of Civil Engineers  
Author of "Topographic Surveying," "Irrigation Engineering," etc.

**MANSFIELD MERRIMAN, C. E., Ph. D.**

Consulting Engineer  
Formerly Professor of Civil Engineering, Lehigh University  
Author of "The Elements of Precise Surveying and Geodesy," "A Treatise on Hydraulics," "Mechanics of Materials," "Retaining Walls and Masonry Dams," "Introduction to Geodetic Surveying," "A Textbook on Roofs and Bridges," "A Handbook for Surveyors," "American Civil Engineers' Pocket Book"

**DAVID M. STAUFFER**

American Society of Civil Engineers; Institution of Civil Engineers; Vice-President, Engineering News Publishing Co.  
Author of "Modern Tunnel Practice"

**CHARLES L. CRANDALL**

Professor of Railroad Engineering and Geodesy in Cornell University  
Author of "A Textbook on Geodesy and Least Squares"

**N. CLIFFORD RICKER, M. Arch.**

Professor of Architecture, University of Illinois; Fellow of the American Institute of Architects and of the Western Association of Architects  
Author of "Elementary Graphic Statics and the Construction of Trussed Roofs"

**W. H. SEARLES, C. E.**

Author of "Field Engineering" and "Railroad Spiral"

**HENRY T. BOVEY**

Late Rector of Imperial College of Science and Technology, London, England  
Author of "Treatise on Hydraulics"

**WILLIAM H. BIRKMIRE, C. E.**

Author of "Planning and Construction of High Office Buildings," "Architectural Iron and Steel, and Its Application in the Construction of Buildings," "Compound Riveted Girders," "Skeleton Structures," etc.

## Authorities Consulted—Continued

IRA O. BAKER, C. E.

Professor of Civil Engineering, University of Illinois  
Author of "A Treatise on Masonry Construction," "Engineers' Surveying Instruments, Their Construction, Adjustment, and Use," "Roads and Pavements"

JOHN CLAYTON TRACY, C. E.

Assistant Professor of Structural Engineering, Sheffield Scientific School, Yale University  
Author of "Plane Surveying: A Textbook and Pocket Manual"

FREDERICK W. TAYLOR, M. E.

Joint Author of "A Treatise on Concrete, Plain and Reinforced"

J. B. JOHNSON, C. E.

Author of "Materials of Construction;" Joint Author of "Design of Modern Frame Structures"

FRANK E. KIDDER, C. E., Ph. D.

Consulting Architect and Structural Engineer; Fellow of the American Institute of Architects  
Author of "Architect's and Builder's Pocketbook," "Building Construction and Superintendence, Part I, Masons' Work; Part II, Carpenters' Work; Part III, Trussed Roofs and Roof Trusses," "Strength of Beams, Floors, and Roofs"

WILLIAM H. BURR, C. E.

Professor of Civil Engineering, Columbia University; Consulting Engineer; American Society of Civil Engineers; Institution of Civil Engineers  
Author of "Elasticity and Resistance of the Materials of Engineering;" Joint Author of "The Design and Construction of Metallic Bridges," "Suspension Bridges, Arch Ribs, and Cantilevers"

WILLIAM M. GILLESPIE, LL. D.

Formerly Professor of Civil Engineering in Union University  
Author of "Land Surveying and Direct Leveling," "Higher Surveying"

GEORGE W. TILLSON, C. E.

Past President of the Brooklyn Engineers' Club; American Society of Civil Engineers; American Society of Municipal Improvements  
Author of "Street Pavements and Street Paving Material"

CHARLES E. FOWLER

Consulting Civil Engineer; Member, American Society of Civil Engineers  
Author of "Practical Treatise on Subaqueous Foundations"

W. M. PATTON

Late Professor of Engineering at the Virginia Military Institute  
Author of "A Treatise on Civil Engineering"



**LIDGERWOOD UNLOADER IN ACTION AT THE TABERNILLA DUMPS**

The plow in the foreground is attached by chain to a power-driven windlass at head of train. As the windlass winds up the chain, the plow pushes the rock from the flat cars.

*Courtesy of Panama Canal Commission, United States Government, Washington, D. C.*



## Foreword

---

**O**F all the works of man in the various branches of engineering, none are so wonderful, so majestic, so awe-inspiring as the works of the Civil Engineer. It is the Civil Engineer who throws a great bridge across the yawning chasm which seemingly forms an impassable obstacle to further progress. He designs and builds the skeletons of steel to dizzy heights, for the architect to cover and adorn. He burrows through a great mountain and reaches the other side within a fraction of an inch of the spot located by the original survey. He scales mountain peaks, or traverses dry river beds, surveying and plotting hitherto unknown, or at least unsurveyed, regions. He builds our Panama Canals, our Arrow Rock and Roosevelt Dams, our water-works, filtration plants, and practically all of our great public works.

**T**he importance of all of these immense engineering projects and the need for a clear, non-technical presentation of the theoretical and practical developments of the broad field of Civil Engineering has led the publishers to compile this great reference work. It has been their aim to fulfill the demands of the trained engineer for authoritative material which will solve the problems in his own and allied lines in Civil Engineering, as well as to satisfy the desires of the self-taught practical man who attempts to keep up with modern engineering developments.

¶ Books on the several divisions of Civil Engineering are many and valuable, but their information is too voluminous to be of the greatest value for ready reference. The Cyclopedia of Civil Engineering offers more condensed and less technical treatments of these same subjects from which all unnecessary duplication has been eliminated; when compiled into nine handy volumes, with comprehensive indexes to facilitate the looking up of various topics, they represent a library admirably adapted to the requirements of either the technical or the practical reader.

¶ The Cyclopedia of Civil Engineering has for years occupied an enviable place in the field of technical literature as a standard reference work and the publishers have spared no expense to make this latest edition even more comprehensive and instructive.

¶ In conclusion, grateful acknowledgment is due to the staff of authors and collaborators—engineers of wide practical experience, and teachers of well recognized ability—without whose hearty co-operation this work would have been impossible.

# Table of Contents

## VOLUME II

RAILROAD ENGINEERING . . . . . *By Walter Loring Webb*† Page \*11

Railroad Surveys—Conflicting Interests—Reconnaissance—Use of Existing Maps—Surveying Methods—Elements of a Survey—Low Ruling Grades—Preliminary Surveys—Cross-Section and Stadia Methods—Composition of Parties—Resurveys—Location Surveys—Selecting a Route—Simple Curves—Methods of Field Work—Locating Points by Deflections—Instrumental Work—Special Methods of Location—Obstacles to Location—Modifications of Location—Compound Curves—Transition Curves—Spiral between Tangent and Circular Curve—Spirals in Old Track—Vertical Curves—Construction—Earthwork—Slopes and Cross-Sections—Width of Roadbed—Ditches—Earthwork Surveys—Position of Slope Stakes—Computing the Volume—Level, Equivalent, and Three-Level Sections—Irregular Sections—Prismoidal Correction—Volume of Earthwork in Irregular Ground—Side-Hill Work—Borrow Pits—Correction for Curvature—Eccentricity of Center of Gravity—Methods of Excavating—Blasting—Formation of Embankments—Tunnel Surveys—Surveying Down-Shafts—Tunnel Design—Cross-Sections, Grade, Lining—Portals—Tunnel Construction—Trestles—Pile-Driving—Trestle Floor-Systems—Guard Rails—Fire Protection—Culverts—Cattle Passes—Water Supply—Turntables—Coaling Stations—Engine Houses—Cattle Guards—Track Construction—Ballast—Rails and Joints—Tie-Plates—Braces, Spikes, Bolts, Nut Locks—Laying Ties and Rails—Switches and Turnouts—Crossings—Yards and Terminals—Signal Systems (Manual, Automatic, Electro-Pneumatic)—Semaphores—Interlocking—Track Maintenance—Work Trains—Railroad Finances: Capitalization, Stocks and Bonds, Gross Revenue, Fixed Charges, Net Revenue, Operating Expenses, Maintenance of Way and Structures, Maintenance of Equipment, Transportation Expenses—Economic Location: General Principles—Reliability and Value of Economic Locations—Distance: Relation to Rates and Expenses—Effect on Receipts—Curvature: Operating Disadvantages, Compensation for Curvature, Limitations—Grade: Distinction between Minor and Ruling Grades, Laws of Accelerated Motion, Virtual Profile, Train Systems, Locomotive Ratings, Units of Operation, Locomotive Types, Power Calculations, Effect of Grade on Tractive Power, Speed Curves—Pusher Grades: Economy, Operation of Pusher Engines, Cost of Service—Balance of Grades for Unequal Traffic

EARTHWORK . . . . . *By A. B. McDaniel* Page 301

Scrapers: Slip—Two-Wheel—Four-Wheel—Graders: Two-Wheel Blade—Four-Wheel Blade—Reclamation—Elevating—Cost of Operation—Power Shovels: Fixed and Revolving Platform Types: Platforms, Power Equipment, Excavating Equipment, Operation, Cost—Electrically Operated Shovels—Efficiency and Economy—Dry-Land Excavators: Stationary Scrapers—Revolving Excavators—Operation Cost—Templet, Wheel, and Tower Excavators—Walking Scoop Dredges—Walking Drag-Line Excavators

REVIEW QUESTIONS . . . . . Page 439

INDEX . . . . . Page 451

\*For page numbers, see foot of pages.

†For professional standing of author, see list of Authors and Collaborators at front of volume.

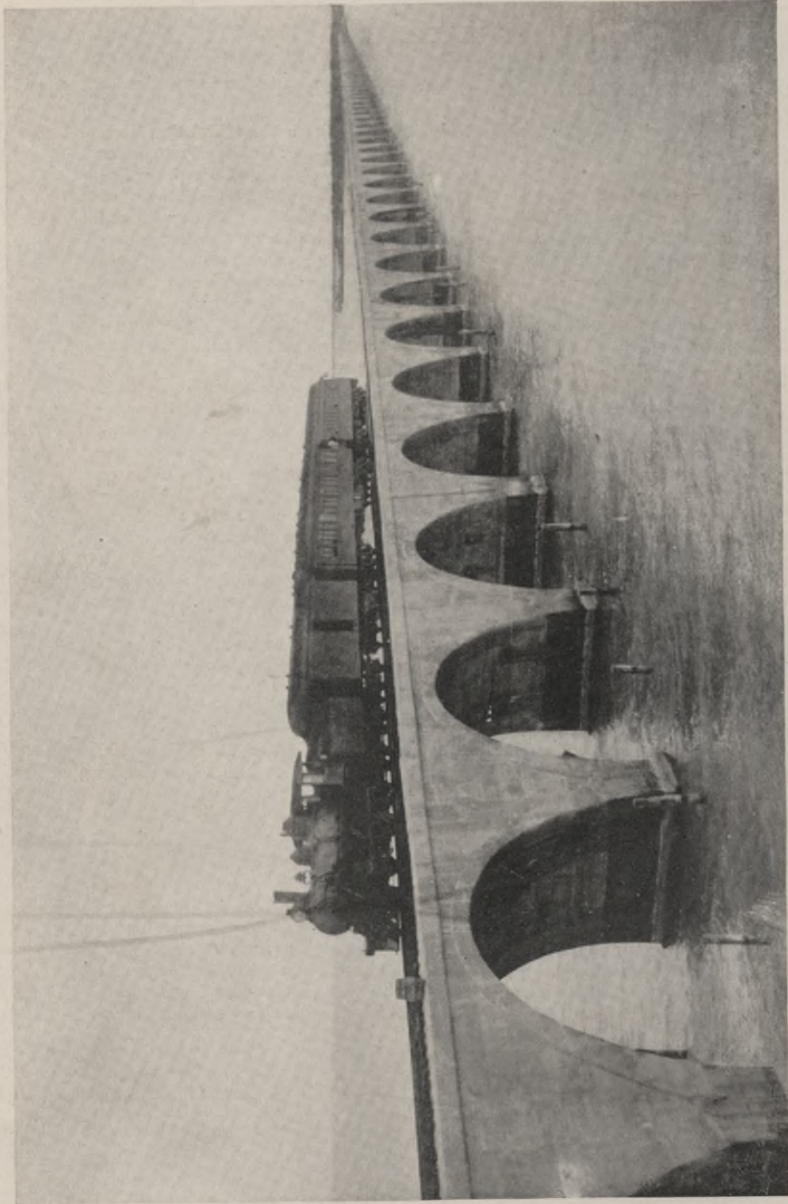

**PORTION OF FLORIDA KEYS RAILROAD**

The view shows the long stretch of concrete construction between the mainland and the keys.

# RAILROAD ENGINEERING.

## PART I.

---

### RAILROAD SURVEYS.

1. **General Principles.** The engineer should have first, a thorough appreciation of the objects to be accomplished by the surveys. He should realize that, except in the rare cases where it is difficult to find *any* practicable line, very little engineering training or ability is required to lay out a line over which it would be physically possible to run trains. A line as laid out may violate all rules of location, may be expensive to operate and have disadvantages which will discourage traffic, and yet trains *can* be run over it. From the infinite number of possible locations, the engineer must select the location which best satisfies the various conflicting interests. His value as an engineer depends on his ability to interpret the natural conditions and design the line accordingly. This ability is only obtained by a thorough knowledge of the whole subject of railroad engineering, supplemented by practical experience. It is therefore true that many of the following statements will not be thoroughly appreciated until the student has covered the whole subject and then reviews it.

2. **Conflicting Interests.** There are several classes of interests, which are generally more or less conflicting, which affect the location of every line.

(a) *The initial cost should be a minimum, but the cheapest road generally has sharp curvature, steep grades and inconvenient location.*

(b) *The operating expenses per train mile should be a minimum, which is generally equivalent to saying that the curvature should be light and the grades low, but this is usually unobtainable except at great cost.*

(c) *The location should be convenient to sources of traffic so that the maximum traffic will be obtained, but this is generally very costly.*

A little study will show the frequent conflict of the above conditions. When a proposed location evidently combines the above interests advantageously, instead of bringing them into conflict, then there is no doubt as to the proper location, unless it affects unduly the adjacent location. The best engineering ability is a cheap investment when deciding on a location which requires a delicate balancing of the claims of several possible routes, each with its own combination of greater or less initial cost, greater or less operating expenses, and greater or less effect on the probable revenue of the road.

### RECONNOISSANCE SURVEYS.

**3. Essential Problem.** From the above considerations it may readily be seen that the first survey to be made (called the reconnoissance survey) consists essentially of a broad examination of the country through which the road is expected to pass. Business considerations usually predetermine that the road is to connect certain termini and also pass through certain intermediate important towns or cities, but the problem consists in finding the best route between the predetermined points. When two consecutive predetermined points lie in the same valley or on the same bank of a river too large to be easily bridged, the location is self-evident. If the river is smaller, easily bridged, has sharp bends, with variable banks and important towns on either bank, it will usually require a close examination of each bank to determine where to cross if at all. When the two points are many miles apart, lie in different valleys, and are therefore separated by one or more summits, the selection of the best route becomes more and more complicated as the number of possible routes becomes greater. It is generally true, although not invariably, that a cross-country route which includes the lowest summits and the highest *low points* (such as river crossings) will give the best grades. Since the "ruling grade" is the most important physical consideration for the engineer, as will be developed later, the chief work of the reconnoissance survey (apart from considerations of probable traffic) is the determination of the elevations of summits and sags and the distance between them, together with the constructive character of the country.

**4. Utilization of Existing Maps.** The U. S. Geological Survey has already published contour maps of a large part of the country which enable an engineer to select a line with even greater ease and certainty than he can from a reconnoissance map made for the purpose (as usually made), since the U. S. G. S. maps show the *whole* country and enable the engineer to rapidly compare a dozen suggested routes instead of confining his attention to the (usually) limited area of the special map. The errors of the U. S. G. S. maps will seldom if ever be sufficient to vitiate the accuracy of the preliminary route laid out from them. Usually a brief study of the map will demonstrate that one (or perhaps two or three) general route has advantages so pronounced over all other possible routes that the choice is immediately made or is at least reduced to the comparison of two or three lines which are so nearly equal that closer and more detailed surveys are necessary to decide between them. County atlases are usually sufficiently accurate for reconnoissance purposes to the extent of giving the relative horizontal positions of governing points of the survey. Elevations may be determined (as described later) and plotted on these maps.

**5. Surveying Methods.** When reliable contour maps are unavailable, some of the following methods may be used to fill out existing maps or to make a complete reconnoissance survey. The essential point is the rapid determination of those details from which one route is shown to be superior to another. Nothing useless should be surveyed and no time should be wasted on an unnecessary degree of accuracy. The physical characteristics of two routes have usually such differences that they are apparent even with rapid and approximate methods of surveying. If two routes are so nearly equal that a decisive choice cannot be made from the results of reconnoissance surveys, it shows that a more accurate survey should be made of both routes.

**6. Elements.** The three elements of the survey of any line are (*a*) the length, (*b*) the direction, and (*c*) the slope or the relative elevation of the two ends. *Distance.* The length is sometimes determined with sufficient accuracy by pacing, the steps being counted with a pedometer. In an open prairie country, where a buggy may be run, an odometer attached to a wheel will count the

revolutions. An odometer on a wheel, attached to a frame and trundled like a wheelbarrow, has been used for the same purpose. A large telescope, mounted with a universal joint on a very light tripod, and fitted with stadia wires so adjusted that distances of 2,000 or even 2,500 feet can be read to the nearest 10 feet on a 10-foot rod, will give the distances between widely separated stations with sufficient accuracy and extreme rapidity. *Direction* may be obtained with sufficient accuracy with a compass—even of the pocket type. *Leveling.* Spirit leveling is too slow and expensive for the rapid surveying here required. If stadia methods are used with an instrument provided for reading vertical angles, the inclination of all lines may be observed and the elevations of all stations computed. A still more rapid method of observing differences of elevation with sufficient accuracy for the purpose is found in the use of an aneroid barometer, supplemented by another aneroid or preferably by a mercurial barometer. The mercurial, or the office aneroid, is kept at some office whose elevation is known and observations are regularly taken (say every half hour) during the period when observations are being taken in the field with the field aneroid. The field aneroid is taken to each place, within a range of several miles, where elevations are desired. At each point there should be noted (see the form of notes below) the time, the described location, the aneroid reading and the temperature. If possible, duplicate readings should be taken on the trip to and from the office on all important points. The elevations of succeeding office locations made, may be determined with the field aneroid if necessary, but of course extra care should be taken with such work.

Aneroids are usually “compensated for temperature,” *i.e.*, so adjusted that they will give a true reading regardless of temperature. If an aneroid has not been so adjusted, it should be carefully compared with a standard mercurial barometer under widely varying conditions of temperature and a tabular form should be made out for that aneroid showing the correction to be applied at any given temperature. On account of the expansion of mercury with temperature, and also the expansion (at a different rate) of the tube and cistern, all readings of the mercurial barometer must be “reduced to 32° F.,” *i.e.*, reduced to the reading it would have, if the temperature of the instrument were 32° F. This is readily ac-



complished by means of Table XI.\* At the office, each half-hourly observation should include the time, the reading of the scale showing the height of the mercury, the reading of the "attached thermometer" (the thermometer attached to the mercurial) and also the temperature of the external air. When the mercurial is indoors these two temperatures may differ somewhat. When reducing the observations interpolation should be made if necessary between the reduced office observations to determine the probable reading of the mercurial at the time of any given field observation. Determine from Table XII\* the heights corresponding to the field reading and reduced office reading for each pair of observations. Their difference is the *approximate* difference of elevation of the office and of the place of the field observation. If necessary this may be corrected by an amount equal to the approximate difference of elevation times a coefficient derived from Table XIII.\* This coefficient is found opposite the number which gives the *sum* of the temperatures in the field and outside the office. The correction is frequently too small to be noticed. An approximate calculation will often show this, or will give a solution to the nearest foot, which is amply accurate. An aneroid, no matter how perfect, will seldom agree exactly with a mercurial barometer, and even if adjusted to the same reading will soon indicate some discrepancy. It is therefore better to leave the adjustment undisturbed and apply corrections. The aneroid should therefore be compared with the mercurial before leaving headquarters for a day's work, and the readings of both and their *difference* should be recorded. Immediately after returning from the day's work the aneroid should again be compared. The absolute reading of the mercurial will probably be higher or lower, but the *difference* should be nearly the same, although it is found that an aneroid will lag somewhat behind its true reading, especially if it has been subjected to an extreme variation of pressure. All the field readings of the aneroid should therefore be corrected by the *mean* of the initial and final differences. The method and the above explanation may be illustrated by the following numerical examples:

**7. Examples.** 1. Given a reading of 28.692 on a mer-

\*See Webb's "Trigonometric Tables," published by American School of Correspondence, Chicago, Ill. Price, 50c.

curial barometer, what is its reading when reduced to  $32^{\circ}$  F., the reading of the attached thermometer being  $68.5^{\circ}$  F.? In Table XI\*, under 28.5 and opposite  $68^{\circ}$ , we find  $-.101$ . Under 29.0 and for  $68^{\circ}$  we find  $-.103$ . For 28.692 and  $68^{\circ}$  it evidently should be  $-.102$  (to the nearest thousandth). Similarly for 28.692 and  $69^{\circ}$  we may derive  $-.105$ . For 28.692 and  $68.5^{\circ}$  it would be the mean or  $-.1035$ , which we will call  $-.103$  since it is useless to compute the correction closer than the nearest thousandth. Then since the correction is  $-.103$ , the corrected reading should be 28.589. With a little practice the interpolations, when necessary, may be made in far less time than it takes to describe it.

2. Verify the following reductions:

Bar. reading.	Temp.	Reduced reading.
26.426	$58^{\circ}$ F.	26.356
27.892	78.5	27.767
28.475	85.	28.330
30.847	48.5	30.792

3. Reduce the following readings: 27.294,  $47^{\circ}$ ; 29.462,  $87^{\circ}$ ; 26.230,  $78.5^{\circ}$ ; 25.241,  $62^{\circ}$ ; 26.481,  $75^{\circ}$ ; 29.625,  $89.5^{\circ}$ ; 30.942,  $88.5^{\circ}$ ; 29.784,  $46.5^{\circ}$ ; 28.386,  $48^{\circ}$ ; 27.942,  $74.5^{\circ}$ .

4. Compute the barometric elevation corresponding to a reading of 28.589. From Table XII\* the reading for 28.5 is 1397 and the difference for .01 is  $-9.5$ ; therefore, for .089 the correction will be  $-9.5 \times 8.9 = -84.55$ , or in whole numbers  $-85$ . Then  $1397 - 85 = 1312$ , the corrected reading.

5. Verify the following elevations from the reduced readings: 26.356, 27.767, 28.330, and 30.792; *i.e.*, 3528, 2107, 1560, and  $-710$ .

6. Compute the barometric elevations corresponding to the *reduced readings* found by solving Example 3.

7. With an approximate difference of elevation of  $-136$  feet and field and office temperatures of  $62^{\circ}$  and  $67^{\circ}$ , what is the true difference of elevation?  $62 + 67 = 129$ . For  $129^{\circ}$  the coefficient is (by interpolation)  $+.0357$ .  $136 \times (+.0357) = +4.8552$ . For this slight difference of elevation, the coefficient is *far* more accurate than necessary, and of course the correction is called  $+5$ .

\*See Webb's "Trigonometric Tables," published by American School of Correspondence, Chicago, Ill. Price, 50c.

The difference of elevation should be *increased* by 5, but the difference is essentially negative. Therefore we have as the correction  $-(+5)$ . The true difference of elevation is  $-136 - (+5) = -141$ .

8. The following example shows not only the method of recording the observations but also the complete solution of a problem.

Time.	Mercurial barometer.	Attached thermometer.	Reduction to 32° F.	Corrected reading.	External thermometer.
7:00 A. M.	28.692	62°	-.087	28.605	60° F.
:30	.724	64	-.092	.632	62
8:00	.756	66.5	-.099	.657	64
:30	.782	68	-.102	.680	65
9:00	.824	69	-.105	.719	66

The observations taken in the field at this time were as given in the first four columns of the following tabular form. The other columns are computed later in the office.

(Left-hand page of notes.)

Time.	Place.	Aneroid.	Therm.	Corrected aneroid.	Corrected mercurial.
7:00 A. M.	Office.....	28.743	62°	.....	28.605
7:20	R. R. Junction.	.769	63	28.631	.623
8:10	Blue River ....	.860	65	.722	.665
8:50	Saddle in Beanpole ridge	.522	66	.384	.706

(Right-hand page of notes.)

Ext. temp. office.	Approx. field reading.	Approx. office reading.	Difference.	Correction for temp.	Difference of elevation.
.....	.....	.....	.....	.....	.....
62°	1273	1280	-7	0	-7
64	1186	1240	-54	-(+2)	-56
66	1508	1201	+307	+12	+319

8. **Low Ruling Grades.** It will be developed later that a low ruling grade is of prime importance. The approximate value of the ruling grade is determined from the reconnoissance survey. If the country is mountainous, it may be necessary to "develop" the line in order to reduce the grade. "Development" here



Fig. 1. Georgetown Spiral.

means a deliberate increase in the length of the line between two predetermined points so that the rate of grade shall be as low as desired. The Georgetown spiral, shown in Fig. 1, is perhaps the most famous example in this country of this general method. A study of the course of the track will illustrate several methods of taking advantage of the topography and attaining a considerable elevation although the grade is kept low.

### PRELIMINARY SURVEYS.

**9. General Object.** The reconnoissance survey has shown that the best location for the road will lie somewhere through a certain belt of country. In some places this belt may be very narrow, *i.e.*, certain topographical features will determine that the road *must* pass through a strip but little if any wider than the roadbed requirements. In other places the choice of possible location is so widened that it is necessary to survey everything within reach of the backbone line of the survey. The willingness or financial ability of the company to ignore minor topographical considerations and incur heavy expense in order to obtain economic advantages, may also widen the area of possible location. As a general statement, the width of the belt surveyed should so vary as to include all practicable locations along that general route.

**10. Cross Section Method.** A broken line is run which shall lie as near the expected location line as possible. The bearing and length of each segment of the broken line is determined and also all essential topographical features on either side. Bearings are sometimes taken only with a compass, which has the advantage of great rapidity but lessened accuracy. For more accurate work, true azimuth is carried along by means of back sights at previous stations. The azimuths between stations should be checked by means of needle readings. It is advisable to determine exact azimuth at the beginning of a survey and at intervals of a few miles. This may be done by observations on Polaris (see Plane Surveying, Part II, Pages 95 to 97), or still better, by solar observations which may be taken with great accuracy at any time of day. Set stakes at each even 100 feet. In general the instrument stations will not occur at the even 100-foot distances, but the odd distance should always be carried on to the next course. The

stakes should be about fifteen inches long and about one-and-one-quarter inches square. Stakes with a cross-section of one inch by one-and-one-half inches are preferred by some. The stakes indicating the 100-foot stations should be driven to within five inches of the ground. Stakes indicating the locations of the transit (called hubs) should be driven flush with the ground. A "witness stake" should then be driven three feet to the right and on this stake should be marked the station number and the "plus-distance"; e.g., the stake might show 137 + 46, which would indicate that the stake was 46 feet beyond Sta. 137, and 13,746 feet from the starting point. Station stakes should be marked with the station number on the *rear* side of the stake. Immediately following the transit party, the level party should obtain the elevations above the datum plane of all stations and substations, ridges, sags, river banks and any point where the profile changes abruptly.

**11. Cross Sectioning.** Use a Locke level, resting on a five-foot stick, a 50-foot tape and a ten-foot rod graduated to feet and tenths. The cross-section party takes cross sections (usually) at every 100-foot stake, the cross section being made perpendicular to the backbone line of the survey at that place, as is indicated by the dotted lines in Fig. 2. It is desired to plot on the map contours at each five-foot interval above the datum plane. Let Fig. 3 represent a typical cross section. Set the level (on its five-foot stick) at the stake S. The elevation of this stake given by the level party is (say) 169.4. The level therefore has an elevation of 174.4. If the level rod is moved up hill until it is found (by trial) that 4.4 mark is on a level with the telescope, then the base of the rod must have a level of 170 and must be on the 170-foot contour. Measure the distance *horizontally* from stake to rod and record as shown in Fig. 4. Leaving the level rod at that point, carry the stick and level up the hill until a level line strikes the top of the rod. The base of the stick is evidently on the 175-foot contour. Measure and record the distance as before. Carry the level rod to that point and in a similar manner determine the 180-foot contour if desired. The 165-foot contour is evidently 9.4 feet below the telescope when on the 5-foot stick at the center stake. The distance from the center to the 165-foot contour can thus be found. Lower contours can be similarly obtained. The results

should be plotted in a note-book ruled in quarter-inch squares, each side of a square representing 25 feet. The work will then be plotted on the scale of 100 feet per inch. If the successive stations are plotted *up* the page, the drawing will correspond with the points when looking ahead along the line. After plotting each section, the corresponding contours should be connected to form a sketch like Fig. 4. The crossing of the main line by a contour may be similarly determined. Fig. 4 is simply an enlarged detail of a sketch like Fig. 2. Although the Locke level is incapable of

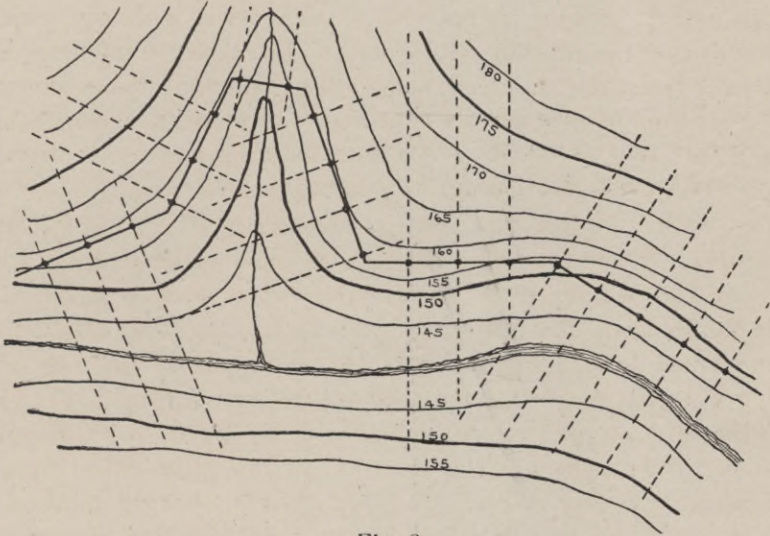

Fig. 2.

accurate leveling work, any error that may be made by the above method is confined to the station where it occurs and is not carried on and made cumulative. With reasonable care such inaccuracies can be kept within desired limits, while the rapidity is far greater than a more accurate method.

**12. Stadia Method.** This consists simply of a stadia survey of a long and narrow belt of country by the same general methods as those employed in ordinary stadia-topographical surveys. One advantage of this method is that the levels can be carried along very successfully as a part of the stadia work, if particular care is taken to always obtain practical agreement in the vertical angles

for the foresight and backsight between consecutive stations. This will generally permit more rapid work, as the progress of the whole party is sometimes limited by the progress of the level

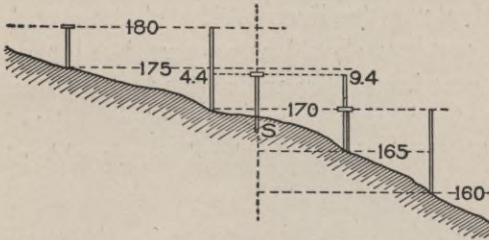

Fig. 3.

party. The added cost of the level party is also saved. It is here assumed that the details of stadia work have already been studied and therefore no further discussion will be given of this very simple application of the general

method. As in the previous method, the primary object of the survey is the preparation of a map showing the contours and required topographical features over the desired area.

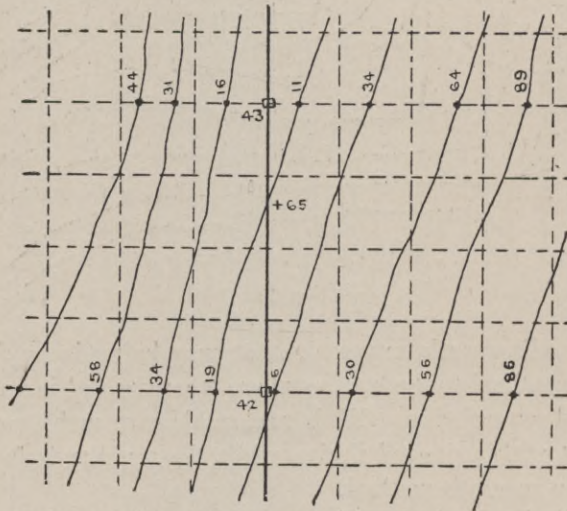

Fig. 4.

**13. Party Required.** It has been forcibly said that the only duty of the *chief-of-party* is to "keep his eyes open". The selection of the best route for a road so depends on a close study of the country that if the chief-of-party is required to do the work



of transitman, as is sometimes the case, the work of either position is apt to suffer. The work of the transitman is so exacting that he should not be required to spend any time in studying out a route. Beside these two, there should be two flagmen, two chainmen, one stakeman and two or more axemen—depending on the wooded character of the country. On stadia surveys the flagmen and chainmen may be replaced by two or more rodmen; it is also economical to have a recorder, as it facilitates the progress of the whole party. The cross-section party should consist of a levelman, recorder, and two tapemen. This party *can* be cut down to three, or in an emergency two, but it is uneconomical in the long run. The level party will consist of a leveler and rodman. If the party is camping out, a cook and one or more teamsters will usually be required to handle the camp equipage, as it is unwise to require the surveyors to spend their time in such work.

**14. Re-surveys.** Much of the defective location of railroads is due to (1) deciding hastily on a general route, (2) then surveying a line through the belt with great detail and accuracy, (3) then locating the line substantially as first surveyed, because the line is fairly good (or at least not very bad), and also because of an unwillingness to throw away the detailed work of a large party for several weeks. Frequently a great amount of unnecessary and wholly useless detail is surveyed and plotted during the reconnoissance and preliminary surveys. These surveys should only include those salient facts which instantly stamp a route as being inferior or superior to another. Usually the general location of a large part of a route is self evident or may be determined after a brief examination. But there are generally places along the line where for a few miles a hasty examination of two or three lines is not only justifiable but is the only proper course. Two or more of these short loops may show advantages so evenly divided that a more elaborate survey is necessary to decide between them. Even after the location survey has been made, or even after construction has begun, changes are often proper, but if the preliminary surveying has been well done only minor changes should be needed. A few hundred dollars spent on extra surveying is a wise investment considering the great probability of an immediate saving of as many thousands in construction or of an

operating advantage whose annual value might be as great as the cost of the extra surveying.

### LOCATION SURVEYS.

**15. Selecting a Route.** Much of the railroad location of the country has been done by picking out the line on the ground, even making it follow in places the backbone line of the preliminary survey, running from one course to the next by means of suitable curves. In the hands of a good engineer the method is not necessarily very bad, but it is much improved by the following modification. *Paper location.* The work of the preliminary survey is carefully plotted from the transit notes and cross-section book to a scale of 200 feet per inch. On this map may be plotted one or more trial location lines. Each of these consists of circular curves joined by tangents. The location line must pass through any predetermined points and yet join them by lines which will give the best location, considering the conflicting interests as described in section 1. Within the limits of the preliminary map several locations are generally possible and one great element of the value of such a map lies in the ease with which several routes may be laid out and compared. Profiles may be drawn for each line laid down by noting the intersection of the line with each contour. Drawing on the profile the required grade line will give a relative idea of the amount of earthwork required. The method is especially valuable when "development" is necessary. Although such a line must sometimes be laid out by a bold and apparently unsystematic trial of a route, yet some approach to a systematic solution may be made as follows: Assume that the maximum ruling grade has been determined as 1.2 per cent, and that the contours have, as usual, a five-foot interval. It will require 417 feet of 1.2 per cent grade to rise five feet. Set a pair of dividers so that they will step off spaces of 417 feet on the map. Starting on a contour at the required beginning of a grade, swing the dividers so that they will just reach the next contour and continue to step off such spaces. Joining these points, such a line would be a purely surface line, would probably be very crooked and otherwise unsuitable, but it probably would be suggestive of a practicable route. After locating on the map the best

obtainable line, it should then be transferred to the ground. Measure to scale the lengths of all "tangents" (the straight lines joining the curves), and the radii and lengths of all curves. Instead of scaling off the *length* of a curve, it may be more accurate to measure with a protractor, or with a scale of chords, the angle between the tangents at each end of the curve, and from the angle and the radius compute the length. Usually the located line will lie fairly close to the preliminary line—close enough so that tie lines may readily be run between them. These should be scaled from the map. To prevent the accumulation of error due to inaccuracies, the length (or radii) of curves or the length of tangents should be altered if necessary so as to make the location check on the ground with the positions of the stakes of the preliminary survey. The method of making such modifications will be taken up later.

**16. Surveying Methods.** Only the most precise work with a transit can be tolerated. The compass needle is only to be used as a check, but its use for this purpose should be insisted on, as it frequently detects a gross error. Transit stations should be marked by "hubs" and "witness stakes" (Section 10). Reference stakes should also be set at places as near as possible to the principal stations and yet outside of the line of all earthwork operations, so that at any stage of the construction the positions of the original stakes may be easily recovered. The link chain as a measurer has now been practically discarded for the steel tape. Fractions of a foot are measured in tenths and hundredths rather than in inches. The *personnel* of the party will be almost identical with that of the preliminary survey party except that the cross section party will be replaced by the slope-stake party, whose duties are similar, but who generally use a level on a tripod rather than a hand level. The description of the duties of the slope-stake party will be deferred to a later chapter. The leveling party should establish "bench-marks" at frequent intervals along the line. A spike driven in the roots of a large tree is one of the best and easiest established of marks in rural districts. A mark on any large masonry structure, such as a bridge abutment or a building, should be obtained when possible. Levels should be taken to hundredths of a foot on turning points and bench marks. Some engineers

read to thousandths of a foot, but when it is considered that one division of a level bubble usually corresponds to 30" of arc, and that at a distance of 150 feet a movement of 30" of arc will correspond to .0218 foot on the rod, an error of level amounting to a very small fraction of a division will make an error of several thousandths or even a hundredth. Therefore unless unusual care is taken in handling the level, it is a useless refinement to read the rod to thousandths. In reading elevations of the surface of the ground, the nearest tenth of a foot is sufficiently accurate. The complete details of location surveys can only be appreciated after the subject of railroad curves has been studied, and they will not therefore be further elaborated here.

### SIMPLE CURVES.

**17. Method of Measurement.** The alignment of a track is the geometrical form of the line midway between the two rails. Such a center line may be a straight line, a simple curve or a curve of double curvature, but it simplifies matters to consider always the *horizontal projection* of such lines. Their vertical projections are considered separately when it is necessary. Curves are sometimes designated by their radius or by the degrees and minutes subtended by a unit chord. Nearly all railroad curves have such long radii that it is impracticable to use the center. Therefore all work is done at the circumference in accordance with geometrical principles which will now be described.

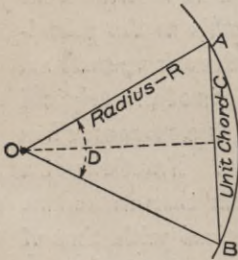

Fig. 5.

If AB, Fig. 5, is a chord of unit length, then D is called the *degree of curve* for the radius R.

$$AO \sin \frac{1}{2} D = \frac{1}{2} AB = \frac{1}{2} C.$$

$$\therefore R = \frac{\frac{1}{2} C}{\sin \frac{1}{2} D} \quad (1)$$



F.W.SYKES.

**AN OBSTRUCTION TO RAILROAD EXTENSION IN SOUTH AFRICA WHICH  
LONG PROVED INSUPERABLE**

Gorge of the Zambesi River below the Victoria Falls, now spanned by a modern steel arch bridge. The waters of the river, two miles wide above the falls, are here confined between 400-foot basalt walls not over 50 yards apart.



which becomes by inversion

$$\sin \frac{1}{2} D = \frac{C}{2R} \quad (2)$$

The length of the unit sub-chord varies somewhat with custom. The almost invariable practice in the United States is to use a unit chord length of 100 feet. Substituting  $C = 100$  in equation 1, and successively assuming values from  $0^\circ 01'$  up to  $12^\circ 0'$  varying by single minutes, and with larger intervals for higher degrees which are very seldom used, the radius of almost any curve may be tabulated for ready and convenient use. Such a table is found in Table I\*, which also gives the logarithm of each radius. A very common rule, which is approximate but accurate enough for many uses, is as follows, using the same notation as before:

$$R = \frac{5730}{D} \quad (3)$$

**18. Sub-Chords.** It often becomes necessary to lay off a chord length which is less than 100 feet and to know the angle subtended at the center. Since a chord is shorter than its arc, it also follows that the sum of the four equal chords in Fig. 6 is also shorter than the total arc although they are evidently longer than the 100' chord. But it is found more convenient to say that the chord has a *nominal* length (in this case) of 25 feet. As in equation (2) we may derive

$$\sin \frac{1}{2} d = \frac{c}{2R} \quad (4)$$

In which  $d$  is the angle subtending the sub-chord whose *true* length is  $c$ . By inversion we have

$$c = 2 R \sin \frac{1}{2} d \quad (5)$$

Calling the *nominal* length  $c'$ , we have the proportion

$$c' : 100 :: d : D$$

\*See Webb's "Trigonometric Tables," published by American School of Correspondence, Chicago, Ill. Price, 50c.

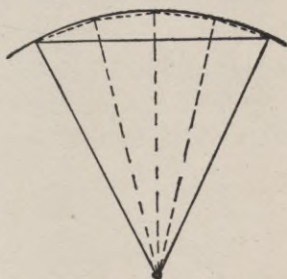

Fig. 6.

## EXAMPLES FOR PRACTICE.

1. What is the true length of a chord of a  $3^{\circ} 30'$  curve whose nominal length is 40 feet? From the above proportion,  $d = \frac{40}{100} D = 0.40 \times 3.5 = 1.4'' = 1^{\circ} 24'$ . Substituting in equation 5, we have

$$c = 2 \times 1637.3 \times \sin \frac{1}{2} (1^{\circ} 24') = 40.005.$$

Note that the *excess* over 40 feet is very small—about one-sixteenth of an inch. It is always small for low degrees of curvature. In the following example it is far greater.

2. What is the true length of a chord of a  $12^{\circ}$  curve whose nominal length is 60 feet? *Ans.* 60.070. In this case it would be a gross error to neglect to allow for this difference.

**19. Length of a Curve.** The length of a curve is always considered to be the quotient of  $100\Delta \div D$ , in which  $\Delta$  is the total central angle of the curve or the angle between the terminal tangents. The mean length of the two rails of a curve is always a little in excess of this, but the excess is always so small that it has no practical importance. It merely adds an insignificant amount to the length of rail required. *Example.* A  $4^{\circ}$  curve begins at Sta. 16 + 80 and runs to Sta. 21 + 35. The *nominal* length of the curve is 455 feet. The actual arc (which is the mean of the two rail lengths) is

$$4.55 \times 4^{\circ} \times R \times \frac{\pi}{180^{\circ}} = 455.09$$

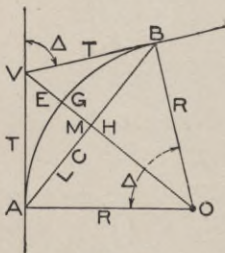

Fig. 7.

which shows that the excess in this case = .09 foot, a little over an inch.

**20. Elements of a Curve.** The following fundamental relations apply to all curves. See Fig. 7. The beginning of the curve, A, is called the *point of curve*, PC. The other end of the curve at B is called the *point of tangency*, PT. The intersection of the two tangents is called the *vertex* (V). The *central angle*,  $\Delta$ , is the angle at V between the tangents, and it is equal to the angle at the center, O, between the radii drawn to the PC and PT. The



two equal tangents AV and BV are called *tangent distances*, T. The chord AB is called the *long chord*, LC. The distance HG from the middle of the long chord to the middle of the arc is called the middle ordinate, M. The distance GV from the middle of the arc to the vertex is called the *external distance*, E. From trigonometry the following commonly used relations are easily derived.

$$T = R \tan \frac{1}{2} \Delta \quad (6)$$

$$LC = 2R \sin \frac{1}{2} \Delta \quad (7)$$

$$M = R \text{ vers } \frac{1}{2} \Delta \quad (8)$$

$$E = R \text{ exsec } \frac{1}{2} \Delta \quad (9)$$

(*Note.* The *versed sine*, abbreviated to *vers*, and the *external secant*, abbreviated to *exsec*, are trigonometrical functions which are not commonly used except in railroad work, and some works on trigonometry omit their discussion. An inspection of the figure readily shows that  $\text{vers } a = 1 - \cos a$ , and that  $\text{exsec } a = \sec a - 1$ .)

From trigonometry we may derive the general equation that  $\tan a \div \text{exsec } a = \cot \frac{1}{2} a$ . Therefore, by dividing equation 6 by equation 9 and transposing we obtain

$$T = E \cot \frac{1}{4} \Delta \quad (10)$$

**21. Elements of a 1° Curve.** The various elements of a curve are exactly proportional to the radius and nearly proportional to the degree of curve. Therefore if the tangents, external distances and long chords are computed from equations 6, 7 and 9 for various values of  $\Delta$  from 1° to 91°, varying by 10', then an approximate value for any degree of curve and value of  $\Delta$  may be found by taking out its value for a 1° curve (by interpolation if necessary) and then dividing that value by the degree of curve. For low degrees of curvature the inaccuracy of this method is usually small

enough to be neglected. Even for sharper curvature the values obtained are accurate enough for approximate work. For absolutely accurate values equations 6 to 9 should be used, but the tabular values, found in Table II\*, may always be used as a check.

**22. Numerical Examples.** 1. What is the tangent distance of a  $3^\circ 10'$  curve whose central angle is  $16^\circ 26'$ ?

$$\begin{aligned} \text{Solution.} \quad \log R &= 3.25757 \\ \frac{1}{2} \Delta &= 8^\circ 13', \log \tan &= \underline{9.15956} \\ \text{Tangent} &= 261.30 \quad \log 261.30 = 2.41714 \end{aligned}$$

Approximate solution. Interpolating in Table II\* between the values for  $\Delta = 16^\circ 20'$  and  $16^\circ 30'$  we have the value 827.36 as the tangent distance for a  $1^\circ$  curve when the central angle is  $16^\circ 26'$ . Dividing 827.36 by 3.1666 ( $3^\circ 10'$ ) we have 261.27 as the approximate value. The inaccuracy is about one-hundredth of one per cent or in absolute value about three-eighths of an inch.

2. Compute the external distance and the long chord for the above curve, both accurately and approximately.

3. Two tangents make an angle of  $18^\circ 24'$ . It is desired to run a line which shall pass 21.2 feet from the vertex of the curve. What is the required radius and the resulting tangent distance?  
*Indicated solution.* The known quantities are E and  $\Delta$ ; from equation 10 we may derive T; then with T known and  $\Delta$  a given quantity, we may compute R by an inversion of equation 6.

## METHODS OF FIELD WORK.

**23. Location of Points by Deflections.** The angle between a tangent to a curve at any point and a secant from that point to any other point of the curve, is measured by one-half of the arc between those points. It is also equal to one-half of the angle between the radii to those points. On this fundamental geometrical proposition depends the whole science of circular-curve location. As a corollary, the angle between two secants intersecting on a point of the curve is measured by one-half of the intercepted arc or by one-half of the angle between the radii drawn to the ends of the intercepted arc. Applying these statements to Fig. 8 we have

\*See Webb's "Trigonometric Tables," published by American School of Correspondence, Chicago, Ill. Price, 50c.

$$TOa = \frac{1}{2} OCa$$

$$aOb = \frac{1}{2} aCb$$

$$bOd = \frac{1}{2} bCd$$

If  $Oa = 100$  feet, then by definition, the angle  $OCa = D$ , and the angle  $TOa = \frac{1}{2} D$ . Likewise if the chord  $ab = 100$  feet, then the angle  $aCb = D$  and the angle  $aOb = \frac{1}{2} D$ .  $bd$  is a subchord subtending the angle  $d$ , and the angle  $bOd = \frac{1}{2} d$ .

Therefore if a transit is set up at the point  $O$ , any point of the curve may be determined by measuring the proper chord length from  $O$  in a direction determined by swinging an angle from the tangent  $OT$  equal to *one-half* of the angle measured at  $C$  between  $O$  and the desired point. But the measurement need not be made directly from  $O$  if other points have already been determined;  $b$  may be determined from  $a$  and  $d$  from  $b$ . Since it is generally impracticable to locate more than 500 feet of curve from any one point, on account of natural obstructions (and sometimes the distance is very short), the transit must be moved up to a new station already established on the curve. But the same principles will apply and may be repeated indefinitely.

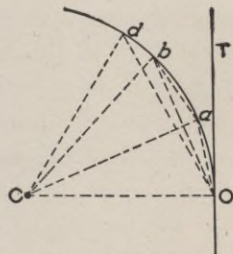

Fig. 8.

**24. Computing the Deflections.** If the point of curve is less than 100 feet from the last regular station, the remainder of the 100 feet must be laid off as a subchord. One-hundred-foot chords are set off until a station is reached which is within 100 feet of the end of the curve or (numerically) until the degrees of central angle remaining is less than  $D$ . That remainder is the angle for the final subchord. The foregoing may be illustrated by a numerical case: A  $4^\circ$  curve is to begin at Sta.  $24 + 40$ . The central angle is  $18^\circ 40'$ . Compute the deflections. The first sta-

tion point is 60 feet beyond the point of curve. The subchord angle is therefore  $\frac{60}{100} \times 4^\circ = 2.4^\circ = 2^\circ 24'$ . The deflection from the tangent is one-half of this or  $1^\circ 12'$ . The deflection for the P.T. is one-half of the total central angle or  $9^\circ 20'$ . Subtracting  $1^\circ 12'$  we have left  $8^\circ 08'$ , which will allow for four deflections of  $2^\circ$  each and  $0^\circ 08'$  over, which will require a chord  $= \frac{0^\circ 08'}{2^\circ} \times 100 = 6.67$  feet. The curve will therefore end at Sta. 29 + 6.67. This may be verified or otherwise computed as follows:  $\frac{18^\circ 40'}{4^\circ} = 4.66667$ , the total *nominal* length of the curve in station lengths of 100 feet. That is, the length will be 466.67. The first subchord is 60 feet; then four chords of 100 feet; then a final subchord of 6.67 feet. The deflections may be tabulated as follows:

P.C. Sta. 24 + 40	0°	
25	0°	+ 1° 12' = 1° 12'
26	1° 12'	+ 2° = 3° 12'
27	3° 12'	+ 2° = 5° 12'
28	5° 12'	+ 2° = 7° 12'
29	7° 12'	+ 2° = 9° 12'
29 + 6.67,	9° 12'	+ 0° 08' = 9° 20', which is one-half of 18° 40' as it should be.

**25. Instrumental Work.** The above numerical case is comparatively simple. When the degree of curve is an odd quantity and when difficulties of location require that the transit be set up at substations on the curve, then the numerical work, although worked out on precisely the same principle, is much greater and chances for numerical error are greater. The following rule for instrumental work is as simple as any for the simple cases and is far better for the more complicated cases. Compute the deflections for all stations and substations as illustrated above. Set up the transit at the P.C., and locate from it all stations that may be conveniently reached. Then move up the transit to a forward station and use the following rule:

*When the transit is set at any forward station, backsight to ANY previous station with the plates set at the deflection angle*

for the station sighted at. Plunge the telescope and sight at any forward station with the deflection angle computed for that station.

The student should verify for himself the truth of this rule by drawing out a simple case and noting the angles both for foresight and backsight for any station, when the transit is located at any station.

Curve location requires extreme care on the part of field men, for a very slight inaccuracy is apt to be multiplied until the error is intolerable. The transit should be very carefully centered over hubs, which should be referred to points which will not be disturbed during construction.

**26. Special Methods of Location.** The above method, using a transit and tape, is the ordinary and preferable method, but it is

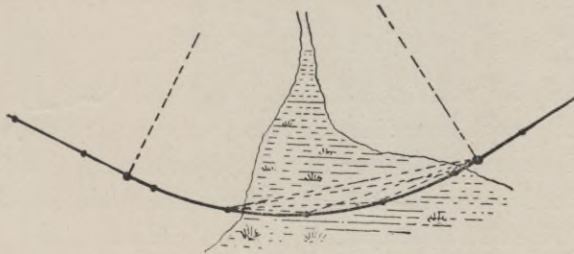

Fig. 9.

sometimes necessary to lay out a curve when a transit is not at hand and there are sometimes special conditions when a modification of the above method will be more accurate. The engineer must have learned the fundamental principles of curve location so thoroughly that he may decide on the best method to use and even to invent some modification which may best suit the special case in hand. A few of these special cases will be described.

(a) *Using two transits.* The location may run over swampy ground where accurate chaining is impracticable. Some point of the curve beyond the swamp may be located, perhaps by triangulation, by computing its angle of deflection and the length of the long chord (equation 7). The point beyond the swamp may or may not be the P. T. Then set up two transits simultaneously at the stations located on firm ground. The deflection of each chord from

the tangent to the curve at the instrument point, or from the long chord, is a simple matter of geometry (see § 23). A rodman can locate each point by placing himself at points where he is simultaneously in line for both transits.

(b) *By tangential offsets.* The solution of this as well as the following methods will be indicated by the lines in the figures.

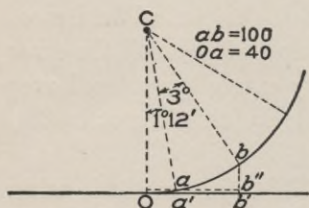

Fig. 10.

In each case the solution is an application of simple geometrical and trigonometrical principles. The solutions are somewhat lengthened, although not essentially modified, when the curve begins or ends with a subchord. In Fig. 10, for example

$$Ob' = Oa' + a'b' = 40 \cos 0^\circ 36' + 100 \cos (1^\circ 12' + 1^\circ 30')$$

$$bb' = b'b'' + b''b = 40 \sin 0^\circ 36' + 100 \sin (1^\circ 12' + 1^\circ 30')$$

and similarly for other points.

(c) *By middle ordinates.* Compute first the length of a long chord for *two* stations and the middle ordinate of such a chord. For subchords, compute the long chord and middle ordinates for an angle *twice* that subtended by the subchord. These distances should be laid off on the ground as indicated in the illustration. In Fig. 11,  $Oa''$  is *half* the long chord for two stations and  $a''a$  equals the middle ordinate for such a long chord. Lay off  $Oa$  on the tangent and measure out the offset  $a''a$ . Measure out  $aa'$  ( $= a''a$ ) so that  $aa'$  is perpendicular

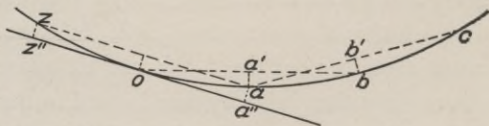

Fig. 11.

to  $Oa'$ , and produce  $Oa'$  to  $b$ .  $Oa'' = Oa' = a'b$ . Thus is  $b$  located, and  $c, d$ , etc., will be located similarly. In Fig. 12,  $an$  is half the long chord for twice the arc  $Oa$ , and  $On$  is its middle ordinate. Compute similarly  $zy$  and  $z''z$ , and lay off on the ground  $a$  and  $z$ . Compute, as in the regular case,  $aa'$  and  $za'$  ( $= a'b$ );  $b$  is then laid off as before.

(d) *By offsets from the long chord.* The geometry involved is apparent from an inspection of Fig. 13, in which is shown the general case of a curve beginning and ending with a subchord. All of the above methods are mathematically perfect in theory, but when curves are thus laid out without the aid of a transit the work is apt to be inaccurate unless unusual care is taken.

### 27. Obstacles to Location.

As in the previous section, the problems are usually simple examples in geometry and trigonometry, and the engineer must select the solution which will give the best result.

#### (a) Vertex inaccessible.

The tangents are frequently fixed by certain conditions, and yet the intersection of the tangents is within a building or in some place where it is impossible to set up a transit.

In the case shown in Fig. 14, the tangents are given by the points  $a$ ,  $b$ ,  $n$  and  $m$ . By measuring the angles  $baV$  and  $abV$  and the distance  $ab$ , the triangle  $abV$  may be solved, and the distances  $aV$  and  $bV$  computed. The external angle at  $V$  is the sum of the angles at  $a$  and  $b$ , and equals the total central angle  $\Delta$ .

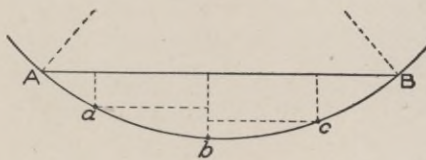

Fig. 13.

Having decided on the radius, the tangent distances are computed by equation 6, and then the differences  $Bb$  and  $Aa$  can be measured off and the P.C. and the P.T. are thus obtained. As a check on the whole work, the curve, run in by the usual methods, should end exactly at B, with the forward tangent coinciding in direction with  $Bn$ .

(b) *Point of curve, or point of tangent, inaccessible.* By making a diagram of the desired line with its obstructions, as in Fig. 15, the known and unknown quantities are readily determined, also their geometrical relations. For example, in the illustration the position of  $V$  (on the ground) is known, as is also the distance

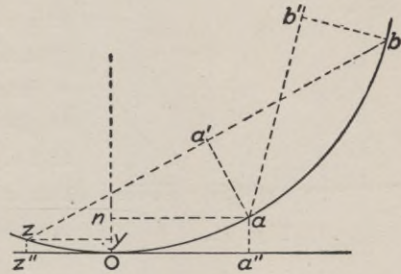

Fig. 12.

AV. Then the *computed* position of A is known. Assume some angle  $a$  such that

$$R \text{ vers } a = As = nv = py$$

where  $s$  is in an accessible position. Then

$$ns = sp = R \sin a$$

and  $n$  and  $p$  can be located on the ground. Then, setting up a transit at  $n$ , and turning from the line  $np$  an angle of  $a$ , the tangent is determined and the remainder of the curve can be run in as usual. If the P.T. is inaccessible, the curve may be run in to some point  $m$ , from which, by similar

calculations and field work, the point  $w$  is obtained, from which the tangent can be continued.

(c) *Middle part of curve obstructed.* The curve may be run as usual to some point  $n$  (Fig. 16) which should preferably, although not necessarily, be an even station. At  $n$  a chord  $nm$  may be run which will clear the obstruction. The angle between  $nm$  and the tangent is one-half the angle measured by the arc  $nm$ . From equation 7, the length of  $nm$  may be computed and then measured off, thus establishing the point  $m$ , from which the remainder of the curve is easily run in. As an illustration of the elasticity of this general method, it might under some conditions be easier to run the dotted curve having the same radius as the required curve could then be found by using the same geometrical principles used in §26 *d*.

**28. Numerical Examples.** All problems have hitherto been so very simple that nothing has been said about the details of solv-

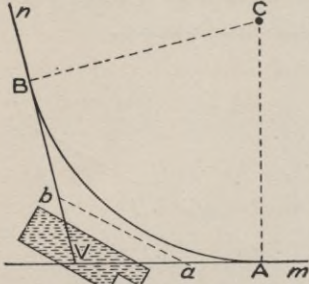

Fig. 14.

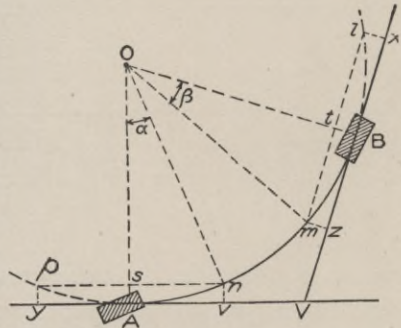

Fig. 15.



ing numerical problems. But as problems become more complicated, the greater becomes the value of a systematic method of solution, which may be readily reviewed, checked and studied for the discovery of a possible error. Logarithms should almost invariably be used for multiplication and division, for they are great time-savers. Even if the student is unaccustomed to them, it pays to become familiar with them. Such methods will be used in the following solutions and the student is urged to solve all such problems similarly.

1. In a case similar to that sketched in Fig. 14,  $ab$  was measured as 476.25; the angle  $Vab$  was measured as  $24^\circ 18'$ , and the angle  $Vba$   $34^\circ 22'$ . The curve is to be a  $3^\circ 30'$  curve. Its radius is therefore 1637.3.  $\Delta = 24^\circ 18' + 34^\circ 22' = 58^\circ 40'$ . Compute  $aA$  and  $bB$ .

	R ( $3^\circ 30'$ )	Logarithms.
Equation 6.		3.21412
	$\tan \frac{1}{2} \Delta = \tan 29^\circ 20'$	9.74969
	T = 920.04	2.96381
	$ab = 476.25$	2.67783
$aV = ab \frac{\sin 34^\circ 22'}{\sin 58^\circ 40'}$	log sin $34^\circ 22'$	9.75165
	co-log sin $58^\circ 40'$	0.06836
	$aV = 314.74$	2.49795
	Tan AV = 920.04	
	$aA = 605.30$	
$bV = ab \frac{\sin 24^\circ 18'}{\sin 58^\circ 40'}$	$ab = 476.25$	2.67783
	log sin $24^\circ 18'$	9.61438
	co-log sin $58^\circ 40'$	0.06846
	$bV = 229.45$	2.36068
	Tan BV = 920.04	
	$bB = 690.59$	

2. Example as in Fig. 15.  $D = 3^\circ 20'$ .  $\Delta = 23^\circ 40'$ . It is estimated that at  $v$ , 180 feet back from  $V$ , the line  $np$  will probably clear the obstruction at  $A$ ;  $ns$  is the difference between 180 and the computed tangent distance  $AV$ ;  $ns \div R = \sin a$ . Then  $nv = py = R \text{ vers } a$ . Locate  $n$  by the offset  $vn$ , and make a

similar offset at  $y$ . If this line does not clear the obstruction, another value of  $a$  (probably greater) should be assumed and new values for  $\Delta v$  and  $vn$  computed. Compute the numerical values as above.

**29. Modifications of Location.** Only a few of the very many changes which are at times required will here be given.

They are all solvable by a few principles of geometry and trigonometry. The occasion for many such changes is the adjustment of the inaccuracies of a "paper location."

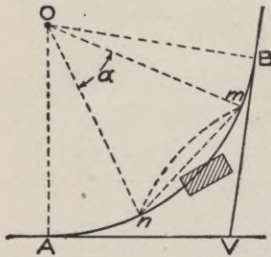

Fig. 16.

(1) *To move the forward tangent parallel to itself a distance  $x$ , the radius remaining unchanged.* See Fig. 17. Every point of the curve is moved parallel to the first tangent a distance  $AA' = BB' = VV' = OO'$ .

$$AA' = \frac{B'n}{\sin nBB'} = \frac{x}{\sin \Delta} \quad (11)$$

(2) *To move the forward tangent parallel to itself, the point of curvature remaining unchanged.* Since the central angle ( $\Delta$ ) is unchanged, the curve and all its parts are simply enlarged or reduced according to some ratio, as is apparent from Fig. 18. The known quantities are the change in the tangent  $x'$  (or  $x''$ ), the central angle  $\Delta$  and the original radius  $R$ .

$$VV' = \frac{V'h}{\sin hVV'} = \frac{x'}{\sin \Delta} \quad (12)$$

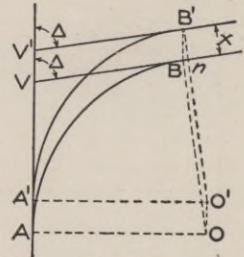

Fig. 17.

Then the new tangent distance  $AV' = AV + VV'$ . The triangle  $BmB'$ , being similar to the triangle  $AO'B'$ , is isosceles and  $Bm = B'm$ . Then the new radius

$$R' = R + mB = R + \frac{B'r}{\text{vers } B'mB} = R + \frac{x'}{\text{vers } \Delta} \quad (13)$$

The modifications of this solution, when the tangent is moved toward the center, are very simple and are apparent from the figure.

(3) *To change the direction of the forward tangent at the point of tangency.* The central angle scaled off from the paper location might have an error which would be best corrected by this means. This solution is but one of a large class in which the central angle is modified. The required change ( $a$ ) in the central angle is one of the given quantities.  $R$ ,  $\Delta$ ,  $AV$  and  $BV$  are also known. In Fig. 19,  $\Delta' = \Delta - a$ ;  $Bs = R \text{ vers } \Delta$ ;  $Bs' = R' \text{ vers } \Delta'$

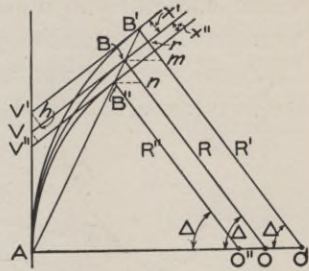

Fig. 18.

$$\therefore R' = R \frac{\text{vers } \Delta}{\text{vers } (\Delta - a)} \quad (14)$$

Also, since  $As = R \sin \Delta$  and  $A's = R' \sin \Delta'$ , we have

$$AA' = A's - As = R' \sin \Delta' - R \sin \Delta \quad (15)$$

**30. Examples.** 1. Given a  $4^\circ 20'$  curve with a central angle of  $18^\circ 28'$ . It is required to move the forward tangent parallel to itself 12 feet. How much is the change of the P.C. (the distance  $AA'$  in Fig. 17)?

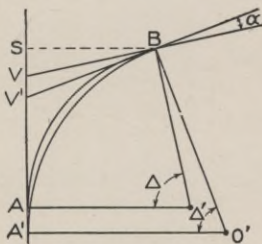

Fig. 19.

2. Given the same curve as above, it is required to move the tangent *toward* the center 12 feet, but without changing the P.C. What will be the changes in the tangent distance and the radius?

3. Given the same curve as above, it is required to *diminish* the central angle by  $0^\circ 22'$ , but retaining the same P.T. What will be the new radius and the change in the P.C.?

**COMPOUND CURVES.**

**31. Definition.** Compound curves consist of a succession of two or more curves of different radii which have a common tangent where they meet. They *may* be laid out by the same method

as simple curves, but there are certain geometrical relations existing between the parts of a compound curve which greatly facilitate the computations, especially when any modifications are required. In the following demonstrations  $R_1$  and  $R_2$  will always represent the smaller and larger radii respectively, no matter which succeeds the other.  $\Delta_1$  and  $\Delta_2$  will always represent the corresponding central angles. Although  $R_2$  is always larger than  $R_1$ ,  $\Delta_2$  may or may not be larger than  $\Delta_1$ .  $T_2$  is always adjacent to the larger radius  $R_2$  and is always larger than  $T_1$ .

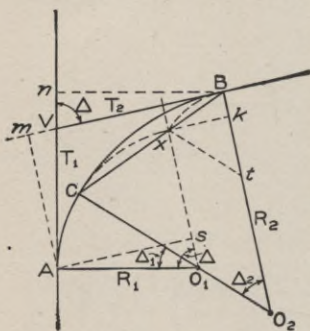

Fig. 20.

$xtB$  will equal  $\Delta_2$ . Then draw  $As$  and  $wk$  perpendicular to  $O_1x$ . Then

$$Bk = xt \text{ vers } xtB = (R_2 - R_1) \text{ vers } \Delta_2$$

$$ws = AO_1 \text{ vers } AO_1x = R_1 \text{ vers } \Delta$$

$$Am = AV \sin \Delta Vm = T_1 \sin \Delta$$

$$Am = Bk + ws$$

$$\therefore T_1 \sin \Delta = R_1 \text{ vers } \Delta + (R_2 - R_1) \text{ vers } \Delta_2 \quad (16)$$

By drawing a few additional lines in the figure, it may similarly be proved that

$$T_2 \sin \Delta = R_2 \text{ vers } \Delta - (R_2 - R_1) \text{ vers } \Delta_1 \quad (17)$$

By algebraic transformation we may derive from equations 16 and 17 the following useful relations. The details of the derivation of these equations is suggested as a profitable exercise for the student.

$$R_2 = R_1 + \frac{T_1 \sin \Delta - R_1 \text{ vers } \Delta}{\text{vers } (\Delta - \Delta_1)} \quad (18)$$

$$R_2 = \frac{T_1 \sin \Delta \text{ vers } \Delta_1 - T_2 \sin \Delta (\text{vers } \Delta - \text{vers } \Delta_2)}{\text{vers } \Delta_2 \text{ vers } \Delta_1 - (\text{vers } \Delta - \text{vers } \Delta_1)(\text{vers } \Delta - \text{vers } \Delta_2)} \quad (19)$$

**33. Modifications of Location.** As in § 29, only a few of the most common modifications will be here illustrated.

1. *To move the forward tangent parallel to itself, but without changing the radii.* From Fig. 21 we derive

$$x = O_2s - O_2's' = (R_2 - R_1) \cos \Delta_2 - (R_2 - R_1) \cos \Delta_2', \text{ from which}$$

$$\cos \Delta_2' = \cos \Delta_2 - \frac{x}{R_2 - R_1} \quad (20)$$

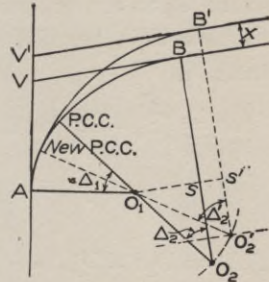

Fig. 21.

Fig. 21 shows the tangent as having been moved *outward*; in such a case the P.C.C. (which means the “point of compound curvature”) is moved *backward* along the sharper curve. If it is desired to move the tangent toward the center, the required equation may be found by transposing  $\Delta_2$  and  $\Delta_2'$  in equation 20. But in this case the sharper curve must be extended and the P.C.C. must be moved *forward*.

In case the larger radius comes first, the figure is apparently quite different, although a little study will show that the same principles apply. From Fig. 22 we derive

$$x = O_1's' - O_1s = (R_2 - R_1) \cos \Delta_2' - (R_2 - R_1) \cos \Delta_1 \text{ from which we have}$$

$$\cos \Delta_1' = \cos \Delta_1 + \frac{x}{R_2 - R_1} \quad (21)$$

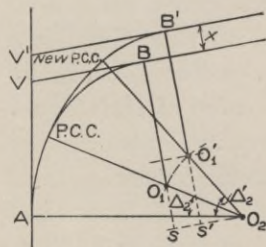

Fig. 22.

Fig. 22 shows the tangent as having been moved *outward*; in such a case the P.C.C. is moved *forward* along the easier curve which is extended. As before, if the tangent is moved *inward*, transpose  $\Delta_1$  and  $\Delta_1'$  in equation. The P.C.C. will then be

moved *backward* along the first curve.

(2) *To change the radius of one of the curves without changing either tangent.* The requirements will be apparent from a “paper” solution. In Fig. 23 assume that the longer

radius, which comes first, is to be shortened by an amount equal to  $sO_2$ . The new center  $O'$  must lie somewhere on the arc whose center is  $O_1$  and whose radius is  $O_1s$ . It also must lie on a line which is parallel to  $AV$  and distant from it by  $R_2'$  which is equal to  $s - P.C.C.$  With  $O_2'$  as center, draw an arc from  $O_1$  to  $m'$ . With  $O_2$  as center, draw an arc from  $O_1$  to  $m$ . It may be proved that  $mm'$  is parallel to  $AV$ . Draw the line  $O_1n$  perpendicular to  $AO_2$ .

$$mn = (R_2 - R_1) \text{ vers } \Delta_2; m'n' = (R_2' - R_1) \text{ vers } \Delta_2'; mn = m'n' \text{ vers } \Delta_2' = \frac{(R_2 - R_1)}{(R_2' - R_1)} \text{ vers } \Delta_2 \quad (22)$$

$$AA' = O_1n - O_1n' = (R_2 - R_1) \sin \Delta_2 - (R_2' - R_1) \sin \Delta_2' \quad (23)$$

**34. Examples.** 1. A  $5^\circ 30'$  curve with a central angle of  $16^\circ 22'$  has a tangent distance of 1800 feet from the P.C. to the vertex. At the P.C.C. the curve compounds into an easier curve. The total central angle is  $30^\circ 18'$ . What is the radius of the easier curve, and what is tangent distance?

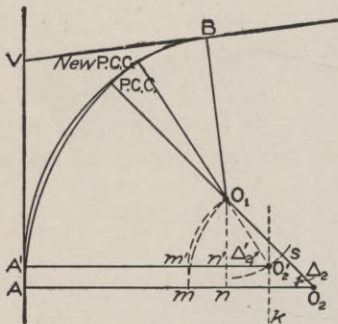

Fig. 23.

*Answer.* The given quantities are  $R_1$  the shorter radius,  $\Delta_1$ ,  $\Delta$ , and  $T_1$ ; the required quantities are  $R_2$  and  $T_2$ . By substituting the known quantities in equation 18 and then the computed value of  $R_2$  in equation 17, the required quantities are

found. The student should perform this numerical work.

2. A  $2^\circ 30'$  curve 450 feet long runs into a  $5^\circ 30'$  curve 260 feet long. It is required to move the forward tangent in 6.4 feet, but without changing either radius. Required the change in the P.C.C. *Comment.* The solution evidently requires the indicated modification of equation 21. It should be noted that a practical solution always requires that the resulting value of the cosine shall be less than unity, which means that  $x$  can never be greater than  $(R_2 - R_1)$ , and also means that the sum of the cosines of the



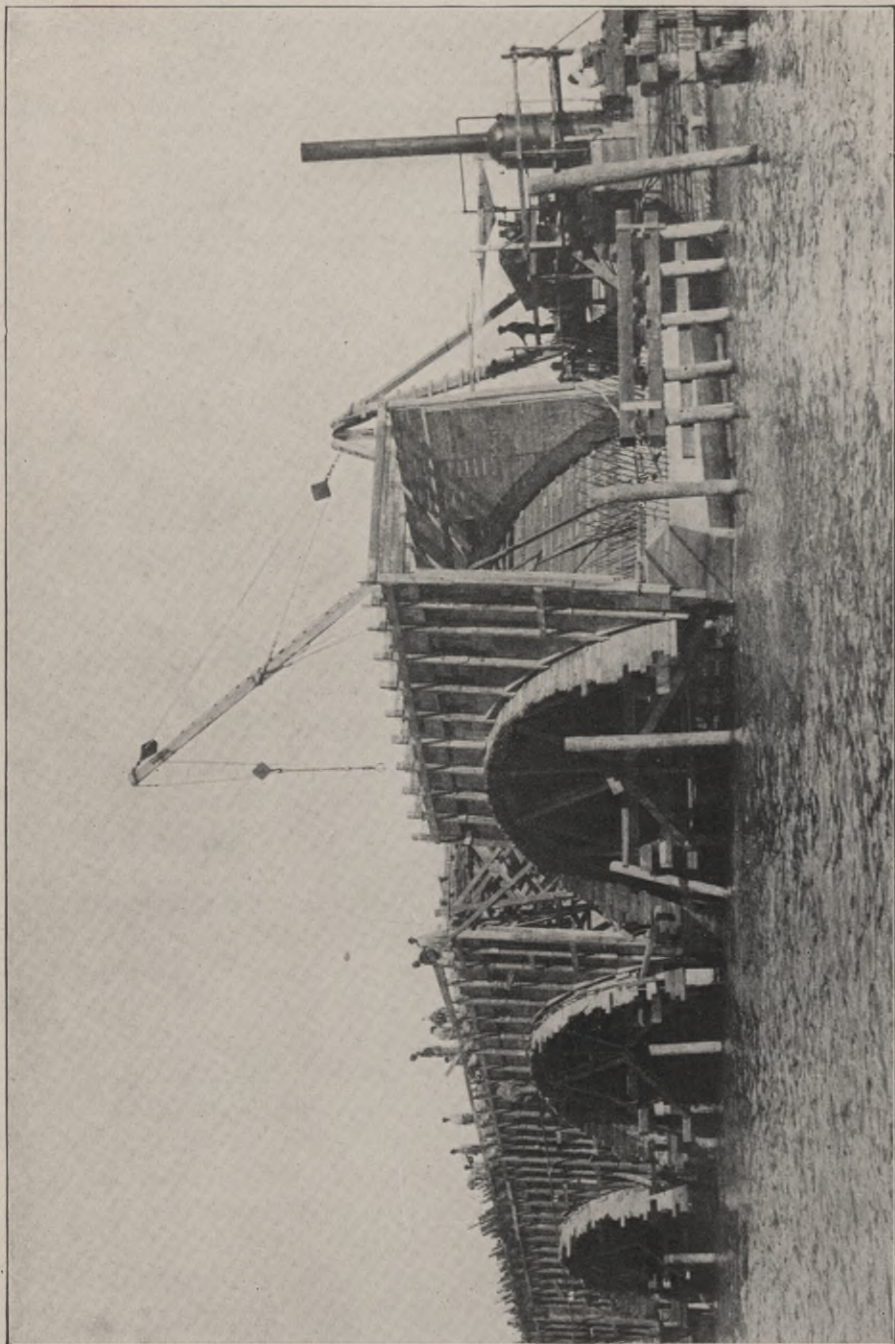

**PLACING OF ARCH FORMS IN CONSTRUCTION OF REINFORCED CONCRETE RAILROAD VIADUCT**  
Long Key viaduct on Key West extension of Florida East Coast Railway. Reinforcing rods protruding from the piers are continued over the ring of the arch. (See finished structure opposite page 11.)



original angle and its modified angle shall be less than unity. The linear change in the P.C.C. may be found by the formula

Linear change = (angular change in degrees)

$$\times (\text{radius of curve}) \times \frac{\pi}{180^\circ}$$

3. Assume the same curve as in example 2, but that it is required to change the  $2^\circ 30'$  curve to a  $2^\circ$  curve without changing the tangents. *Comment.* Fig. 23 may be made to apply by transposing the new and old larger radii, and their corresponding central angles. Note that when such changes are made in equation 22, the equation is unchanged. The effect on equation 23 is merely to change the algebraic sign, which means that the P.C.C. is moved *backward* instead of forward.

4. Draw a figure corresponding to Fig. 23 but showing a change in the smaller radius  $R_1$ .

### TRANSITION CURVES.

**35. Transition Curve Systems.** *General Use.* When a train, or any other mass, is in motion it requires a definite force to make it move in a curved path. If the two rails of a railroad curve are level transversely, this centripetal force can only be furnished by the pressure of the wheel flanges against the outer rail. To avoid such a dangerous pressure, which would make high speed impracticable, the outer rail is made higher than the other. But it is manifestly impracticable to suddenly raise the outer rail at the beginning of a curve and lower it as suddenly at the end of the curve. There must be a "run-off" of considerable length. If this run-off were placed exclusively on the tangent, there would be an objectionable jar because the cars were tipped on a straight track where there is no compensating centrifugal force. If the run-off were entirely on the curve there would be a jar, because the centripetal force would not become fully developed at the beginning of the curve; and, therefore, a transition curve is used at the beginning and end of the curve. The transition curve is one whose rate of curvature gradually increases from nothing to the rate of the central part of the curve. If the super-elevation of the outer rail is begun at the beginning of the transition curve and is grad-

ually increased as the curvature increases so that the proper super-elevation is attained at the end of the transition curve where the regular curve commences, then the theoretical requirements are satisfied. But there is another important reason for transition curves. On a curve the bogie trucks of a car make an angle with the axis of the car. If there were an instantaneous change from a straight track to the full degree of curvature the change of position of the truck would need to be accomplished in the time required for its train to run the distance between the truck centers of a car. For a high-speed train this distance would be covered in less than a second. On a transition curve this change of position is accomplished gradually and without jar. The amount of the required super-elevation will be discussed in the following sections.

*Varieties of Curves.* A theoretically exact transition curve is very complicated and its mathematical solution very difficult. Many systems of curves have been proposed, all of which are objectionable for some one of the following reasons, as stated in a report by a Committee of the American Railway Engineering Association. "(1) If simple approximate formulas were used they were not sufficiently accurate. (2) Accurate formulas were too complex. (3) The curve could not be expressed by formulas. (4) Formulas were of the endless series class. (5) Complex field methods were required to make the field work agree with formulas with spirals of large central angles." The Committee then developed a method which gives results whose accuracy is beyond that of the most careful field work and yet which is sufficiently simple for practical use. The mathematical development is too elaborate to be detailed here but the working formulas, together with a condensation of the Tables will be given, together with an explanation of their practical use and application, with examples.

The general form of these curves, whatever their precise mathematical character, is shown in Fig. 24. AVB are two tangents, joined by the simple circular curve ACB, having the center O. Assume that the entire curve is moved in the direction CO a distance  $OO' = CC' = BB' = AA'$ . At some point TS on the tangent, the spiral begins and joins the circular curve tangentially at SC. The other spiral runs from CS to ST. The significance of these symbols

may be readily remembered from the letters; T, S, and C signify tangent, spiral, and circular curve; TS is the point of change from tangent to spiral, SC the point of change from spiral to curve, etc. At the other end of the circular curve, the letters are in the reverse order, the station numbers increasing from A to B. The meaning of each of the various symbols used is plainly indicated on the diagram, Fig. 24.

The *length* of a spiral can only be computed on the basis of certain assumptions as to the desired rate of tipping the car, so as to avoid discomfort to passengers, and of course this depends on the expected velocity. There is also a limitation since the sum of the two spiral angles cannot exceed the total central angle of the curve. The *minimum* lengths recommended are as follows:

On curves which limit the speed:

- 6° and over, 240 feet
- less than 6°,  $5\frac{1}{3} \times$  speed in m.p.h. for elevation of 8 inches

On curves which do not limit the speed:

- 30 times elevation in inches, OR
- $\frac{2}{3} \times$  ultimate speed in m.p.h.  $\times$  elevation in inches

For example. (1) 5° curve which limits speed; speed limit 48 m.p.h. by interpolation in table, § 41;  $48 \times 5\frac{1}{3} = 256$  feet minimum length. (2) 3° curve; maximum operating speed 60 m.p.h.; super-elevation .62 feet = 7.44 inches;  $30 \times 7.44 = 223.2$  feet; OR,  $\frac{2}{3} \times 60 \times 7.44 = 297.6$  feet. Of course the higher value should be used, or say 300 feet as the minimum length. While it is generally true that the longer transition curves give easier riding, the spiral must

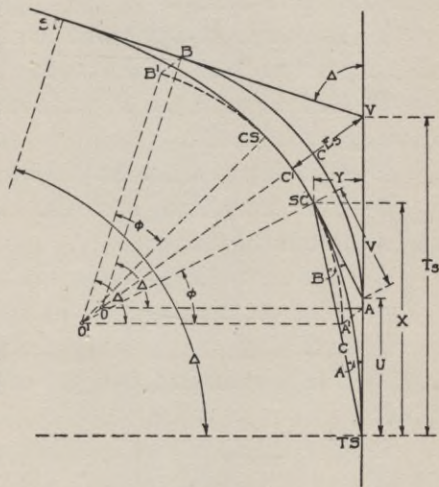

Fig. 24.

not reach the center point of the curve. Since it is approximately true that the spiral extends for equal distances on each side of the original point of curve, it is nearly true that two spirals, each having the same length as the original curve, would meet at the center. The length of a spiral should in general be far less than the length of the original curve.

**36. Symbols.** Besides the symbols whose significance is clearly indicated in Fig. 24, the following are defined:

$a$ —The angle between the tangent at the TS and the chord from the TS to any point on the spiral.

$A$ —The angle between the tangent at the TS and the chord from the TS to the SC.

$b$ —The angle at any point on the spiral between the tangent at that point and the chord from the TS.

$B$ —The angle at the SC between the chord from the TS and the tangent at the SC.

$D$ —The degree of the central circular curve.

$\Delta$ —The central angle of the original circular curve, or the angle between the tangents.

$\phi$ —The central angle of the whole spiral.

$\phi_1$ —The central angle of the spiral from the TS to the first spiral point.

$k$ —The increase in the degree of the curve per station on the spiral.

$L$ —The length of the spiral expressed in feet from the TS to the SC.

$s$ —The length of the spiral in stations from the TS to any given point.

$S$ —The length of the spiral expressed in stations from the TS to the SC.

**37. Deflections.** The field formulas for deflections are based on the following two equations

$$a = 10ks^2 \text{ minutes} = \frac{1}{3}\phi_1$$

$$a = 10kS^2 \text{ minutes} = \frac{1}{3}\phi$$

The first deflection  $a_1 = 10ks_1^2$  minutes. But  $k$  is the increase in

degree of curve per station and since the degree of curve increases as the length  $k=D \div S$ ,  $S$  being expressed in stations. For point 1, since  $S=10s$ ,  $a_1=10 \left( \frac{D}{10s} \right) s^2 = Ds$ , which may be expressed as the degree of curve times the length of the chord in stations. For example, if the spiral is 400 feet long ( $L=400$  and  $S=4$ ) and runs on to a  $5^\circ$  curve ( $D=5$ ), one chord is 40 feet long or  $s=.4$  stations. Then  $a_1=5 \times 0.4=2$  minutes of arc for the deflection for the first chord point. And since the deflections are as the square of the number of stations, the deflections from TS to succeeding stations will be 4, 9, 16, 25, 36, 49, 64, 81, and 100 times 2 minutes, as shown in the second vertical column of Part A of Table IV. The last deflection  $A=100 \times 2' = 200' = 3^\circ 20' = \frac{1}{3} (10^\circ) = \frac{1}{3} \phi$ , which is the total central angle of the spiral. This result also checks the general equation

$$\phi = \frac{kS^2}{2} = \frac{DS}{2} = \frac{kL^2}{20000} = \frac{DL}{200}$$

Since

$$\phi = \frac{DS}{2} = \frac{5 \times 4}{2} = 10^\circ$$

The deflections from any point of the spiral to any other point, either forward or backward, may be found by multiplying the value of  $a_1$  (in this case  $2'$ ) by the coefficients in the proper vertical column of that table. The values of the ratios  $\frac{U}{L}$  and  $\frac{V}{L}$  for even degrees and for  $A$ ,  $\frac{C}{L}$ ,  $\frac{X}{L}$ , and  $\frac{Y}{L}$  for half degrees are given in Parts B and C, Table IV.

**38. Insertion of a Spiral between a Tangent and a Circular Curve.** In Fig. 25 it has been necessary to make the distance  $MM'$  about 100 times its real proportional value in order to make the illustration distinct. The curve  $AMB$  is a simple circular curve joining the two tangents, such as would be used without spirals. If a suitable spiral is started at a suitable point  $Q$ , and run to some point  $Z$ , such that the total central angle of the spiral,  $\phi$ , equals the angle  $ZO'N$  of the curve, and then the circular curve having a common tangent with the spiral at  $Z$ , is run to  $Z'$ , from

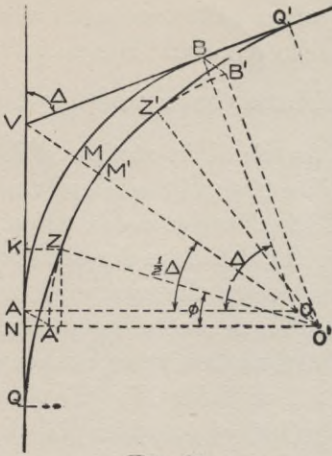

Fig. 25.

$$A'N = y - R \text{ vers } \phi.$$

Therefore,

$$m = MM' = AA' = BB' = \frac{A'N}{\cos \frac{1}{2} \Delta} = \frac{y - R \text{ vers } \phi}{\cos \frac{1}{2} \Delta} \quad (24)$$

$$NA = AA' \sin \frac{1}{2} \Delta = (y - R \text{ vers } \phi) \tan \frac{1}{2} \Delta$$

$$VQ = QK - KN + NA + AV$$

$$= x - R \sin \phi + (y - R \text{ vers } \phi) \tan \frac{1}{2} \Delta + R \tan \frac{1}{2} \Delta$$

$$= x - R \sin \phi + y \tan \frac{1}{2} \Delta + R \cos \phi \tan \frac{1}{2} \Delta \quad (25)$$

As a numerical solution of any problem will usually involve the determination of the value of  $A'N$ , equation 25 may be reduced from four terms to three as follows: Transform the equation above equation 25 to read

$$VQ = x + R (\tan \frac{1}{2} \Delta - \sin \phi) + A'N \tan \frac{1}{2} \Delta \quad (26)$$

$$VM' = VM + MM' = R \text{ exsec } \frac{1}{2} \Delta + \frac{y}{\cos \frac{1}{2} \Delta} - \frac{R \text{ vers } \phi}{\cos \frac{1}{2} \Delta} \quad (27)$$

$$AQ = VQ - AV = x - R \sin \phi + (y - R \text{ vers } \phi) \tan \frac{1}{2} \Delta \quad (28)$$

**39. Example.** It is required to join two tangents which make an angle of  $28^\circ 16'$  by a curve terminated by suitable spirals. Assume a 10-chord spiral 240 feet long. Then

$$\phi = \frac{DL}{200} = \frac{6 \times 240}{200} = 7.2^\circ = 7^\circ 12'$$

From Part C, Table IV, when  $\phi = 7.2^\circ$

$$\frac{X}{L} = .998517 - \frac{2}{5} (.998517 - .998298) = .998430$$

$$X = .998430 \times 240 = 239.623$$

$$\frac{Y}{L} = .040681 + \frac{2}{5} (.043581 - .040681) = .041841$$

$$Y = .041841 \times 240 = 10.042$$

$$\frac{1}{2} \Delta = 14^\circ 8'$$

(Equation 24)

			Logarithms
		R	2.98017
Y	10.042	vers $7^\circ 12'$	7.89682
	7.533		<u>0.87699</u>
A'N	2.509	cos $\frac{1}{2}\Delta$	<u>0.39950</u>
			9.98665
$m = MM' = AA'$	$= 2.587$		<u>0.41285</u>

(Equation 27)

		R	2.98017
		exsec $\frac{1}{2}\Delta$	8.49436
VM	$= 29.821$		<u>1.47453</u>
$m$	$= 2.587$		
VM'	$= 32.408$		

(Equation 26)

$$\text{nat. tan. } \frac{1}{2}\Delta = 0.25180$$

$$\text{nat. sin } \phi = \frac{0.12533}{0.12647}$$

$$x = 239.623$$

$$120.825$$

(see above)

$$\frac{0.632}{VQ} = 361.080$$

		9.10198
		R <u>2.98017</u>
		<u>2.08215</u>
A'N		0.39950
tan $\frac{1}{2}\Delta$		<u>9.40106</u>
AN		<u>9.80056</u>
		R <u>2.98017</u>
tan $\frac{1}{2}\Delta$		<u>9.40106</u>
AV		2.38123

(Equation 28)

$$\frac{240.564}{AQ} = 120.516$$

**40. Insertion of Spirals in Old Track.** An engineer frequently has occasion to insert spirals in track which was not so laid out. The simplest method from a mathematical standpoint is that given in the two previous sections. But this would involve moving the whole track for the entire length of the curve, and

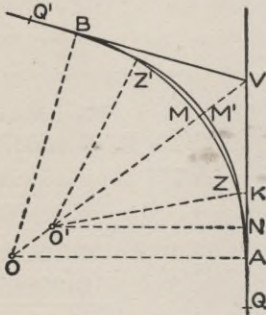

Fig. 26.

also, since it is apparent from Fig. 25 that the new line  $QZZ'Q'$  is shorter than the old line  $QAMBQ'$ , the method will involve rail cutting and the boring of holes for track bolts. The following method makes a slight sharpening of curvature of the middle circular section, which at the center is slightly *outside* of the old track, and so crosses the old line that the lateral deviation from the old line is always very small and the length of the new track need not differ appreciably from that of

the old. The method of solution is indicated in Fig. 26.

$$O'N = R' \cos \phi + y \quad (\text{This shows more clearly in Fig. 25.})$$

$$O'V = O'N \sec \frac{1}{2}\Delta$$

$$= R' \cos \phi \sec \frac{1}{2}\Delta + y \sec \frac{1}{2}\Delta$$

$$m = MM' = MV - M'V$$

$$= R \operatorname{exsec} \frac{1}{2}\Delta - R' \cos \phi \sec \frac{1}{2}\Delta - y \sec \frac{1}{2}\Delta + R' \quad (29)$$

$$AQ = QK - KN + NV - VA$$

$$= x - R' \sin \phi + (R' \cos \phi + y) \tan \frac{1}{2}\Delta - R \tan \frac{1}{2}\Delta$$

$$= x - R' \sin \phi + R' \cos \phi \tan \frac{1}{2}\Delta - (R - y) \tan \frac{1}{2}\Delta \quad (30)$$

$$\text{The length of the old line from } Q \text{ to } Q' = 2AQ + 100 \frac{\Delta}{D}. \quad (31)$$

$$\text{The length of the new line from } Q \text{ to } Q' = 2L + 100 \frac{\Delta - 2\phi}{D'},$$

in which  $L$  is the length of each spiral.



41. **Example.** Assume that a track has been laid with a  $6^\circ$  curve for  $39^\circ 50'$ : It is desired to insert suitable spirals without altering the length of the old track. *Solution.* Unfortunately there is no method of solving this problem so as to obtain directly the revised value for the radius: The new radius will always be about 5 per cent shorter than the old. The larger the central angle, the less will be the difference. The only method is therefore to assume a value for  $R'$ , solve equation 30, and then compare the lengths of the new and old lines. If the difference is so small that it may be neglected, the problem is solved. If not, a slight modification of the new radius, such as experience in these computations will suggest, will usually give on a second trial a value which is sufficiently close. As a first trial for the above numerical case, we will assume a  $6^\circ 20'$  curve for the new curve, and a 240 ft. spiral whose  $\phi = 7^\circ 36'$ .  $x = 239.580$  and  $y = 10.60$ .

	Logarithms.
$x = 239.580$	$R' (6^\circ 20')$ 2.95671
	$\sin 7^\circ 36'$ 9.12141
119.709	<u>2.07812</u>
	$R'$ 2.95671
	$\cos 7^\circ 36'$ 9.99617
	$\tan \frac{1}{2} \Delta$ 9.55909
325.069	<u>2.51197</u>
	$R = 955.37$
	$y = 10.60$
	<u>944.77</u> 2.97532
	$\tan \frac{1}{2} \Delta$ 9.55909
	<u>2.53442</u>
<u>342.310</u>	
<u>564.649</u>	<u>462.019</u>
<u>462.019</u>	

AQ = 102.630

The length of the old curve from Q to Q' is

$100 \frac{\Delta}{D} = 100 \frac{39.83333}{6} =$	663.889
$2 AQ = 2 \times 102.630 =$	<u>205.260</u>
	869.149

The length of the new curve from Q to Q' is

$$100 \frac{\Delta - 2\phi}{D'} = 100 \frac{39.8333^\circ - 15.2^\circ}{6.333^\circ} = 388.947$$

$$2L = 2 \times 240' =$$

$$480.000$$

$$868.947 \quad \underline{868.947}$$

$$\text{Difference in length} = 0.202$$

When it is considered that in that length of 869 feet there will be about 27 rail joints and that a stretching at each joint of about .0075 foot will make up for this difference of length, it might not be necessary to cut the rails.

To illustrate the method of adjustment if a more accurate value for R' were required; note that in the above case the new curve is too short. If R' is diminished (say from D' = 6° 20' to D = 6° 24'), one term of equation 30 will be increased and one of them diminished, but the net change in the value of AQ is 3.403, which will decrease the length of the old curve by 6.806. But such a change in D' will decrease the length of the new line by 6.552.

The revised length of the old line is, therefore, 862.343 and the revised length of the new line is

$$\underline{862.395}$$

The revised difference is 0.052

The new line is now longer than the old, but the difference is insignificant (about one fortieth of an inch per joint). By interpolation D' = 6° 23' is the better value to use.

There is another method of introducing a spiral into old track without even changing the central part of the curve. The spiral runs into a curve which is sharper than the original curve which then compounds into the old curve. The solution of this method consists in so choosing and locating the spiral and the sharper curve that it will compound into the original curve. The details of this method will not be here given because, although it involves less track work at the start, it is a more complicated alignment to maintain and the method is inferior to the one previously given.

On the basis of  $D' = 6^\circ 20'$

(Equation 29)

$$R' = \frac{60.776}{965.906}$$

954.255

$$965.529$$

$$\frac{11.274}{965.529}$$

$$m = 0.377 \text{ foot}$$

	Logarithms.
R (6°)	2.98017
exsec $\frac{1}{2}\Delta$	<u>8.80356</u>
	<u>1.78373</u>
R'	2.95671
cos $\phi$	9.99617
sec $\frac{1}{2}\Delta$	<u>0.02678</u>
	<u>2.97966</u>
log $x =$	1.02530
sec $\frac{1}{2}\Delta$	<u>0.02678</u>
	<u>1.05209</u>

Note that the maximum lateral change in the track is less than five inches.

On many railroads where there has been no pretense to using spirals the track foremen have produced nearly the same result in a rough uncertain way by throwing in the curve somewhat near the point of curve. This necessarily sharpens the curve further on, and thus substantially the same result is obtained as is described above but without any calculations or any theoretical accuracy. It is only by such means that a tolerable riding track can be produced when transition curves are not used.

**42. Use of Transition Curves with Compound Curves.** It is shown in the last few sections that the lateral deviation involved by the use of spirals is very small. Since compound curves are usually employed only when the location is difficult, it is best to make the calculations as if no spirals were to be used, except that approximate allowances may be made for such lateral changes as will be required. Then the changes can be computed as follows. Theoretically there should be a transition curve between the two branches of a compound curve, but when a train is already on a curve and the wheels are pressing against the outer rail, it will cause but little jar to merely increase the curvature. The intro-

duction of such spirals will not be here given. Transition curves need not be used in running on to curves which are easier than  $3^\circ$  and even  $4^\circ$ . Therefore if one branch of a compound curve is of easy curvature, as is frequently the case, it will not be necessary to use a spiral at that end of the curve.

Therefore two cases will be developed—using spirals at one end only, and at both ends.

(a) *Spiral at one end only.* The method of §38 may be adopted by substituting  $\Delta_1$  for  $\frac{1}{2} \Delta$  in equations 24 to 28. This would move the P.C.C. from  $M$  to  $M'$ . But since the two curves *must* be made to coincide, the sharper curve will be moved parallel to the tangent  $BV$  a distance of  $M'M$ , while the

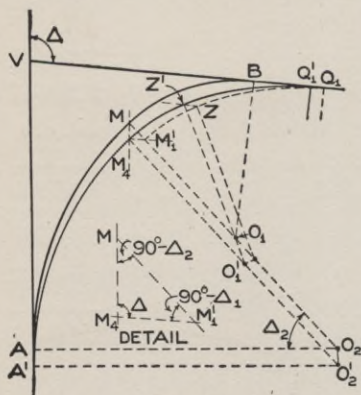

Fig. 27.

unchanged circular curve will be moved parallel to the tangent  $AV$  a distance  $MM_4$ . Calling  $MM' = m_1$ , we have, Fig. 27,

$$M_1'M_4 = MM_1' \frac{\sin M_1'MM_4}{\sin M_1'M_4M} = m_1 \frac{\sin (90^\circ - \Delta_2)}{\sin \Delta} = m_1 \frac{\cos \Delta_2}{\sin \Delta} \quad (32)$$

$$MM_4 = m_1 \frac{\cos \Delta_1}{\sin \Delta} \quad (33)$$

It should be noted that the new P.C. is at  $A'$  and that  $AA' = MM'$ , while the P.T. is changed from  $B$  to  $Q_1'$ , which equals  $BQ_1 - QQ'$ .  $BQ_1$  is found from equation 28 and  $Q_1'Q_1 = M_1'M_4$  is found from equation 32.

(b) *Spiral at both ends.* Applying the method of §38 to each branch of the curve in turn by successively substituting  $\Delta_1$  and  $\Delta_2$  for  $\frac{1}{2} \Delta$ , we will obtain values for  $m_1$  and  $m_2$  which will in general differ considerably. But as before we may move each revised curve as shown in Fig. 28 and as computed in equations 34 and 35. Calling  $MM_1' = m_1$  and  $MM_2' = m_2$ , and noting that the angle at  $M_1'$  (see the detail) =  $90^\circ - \Delta_1$ , the angle at  $M_2'$

=  $90^\circ - \Delta_2$  and the angle at  $M_3 = \Delta$ , we have the following:

$$M_1'M_3 = M_1'M_2' \frac{\sin(90^\circ - \Delta_2)}{\sin \Delta} = (m_1 - m_2) \frac{\cos \Delta_2}{\sin \Delta} \quad (34)$$

$$M_2'M_3 = M_1'M_2' \frac{\sin(90^\circ - \Delta_1)}{\sin \Delta} = (m_1 - m_2) \frac{\cos \Delta_1}{\sin \Delta} \quad (35)$$

As in the previous case, the position of the new point of the spiral is found in each case from one of the above quantities and the change computed from equation 28. Note that in one case the point of spiral is moved nearer to, and in the other case further away from, the vertex.

**43. Example.** Given a  $7^\circ 20'$  curve for  $29^\circ 40'$  followed by a  $4^\circ 10'$  curve for  $25^\circ 20'$ . Required to introduce suitable spirals. Using equation 24 successively with the two sets of figures we obtain  $m_1 = 5.506$  and  $m_2 = 1.930$ . Then  $(m_1 - m_2) = 3.576$ . Substituting this value in equations 34 and 35 we obtain  $M_1M_3 = 3.946$  and  $M_2'M_3 = 3.793$ . Using

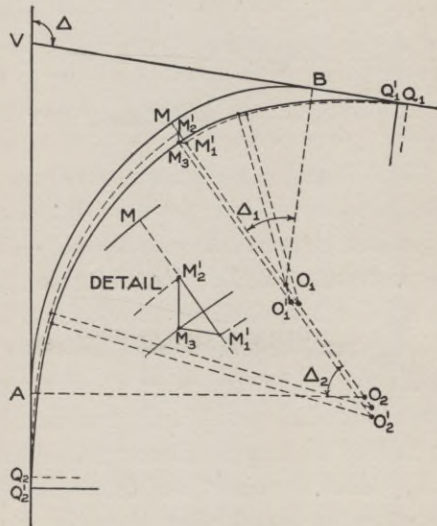

Fig. 28.

equation 28, calling  $\frac{1}{2}\Delta =$

$25^\circ 20'$ , we compute  $AQ_2 = 120.769$ . But we must *add* to this an amount equal to  $M_2'M_3 = 3.793$ , which makes  $AQ_2' = 124.562$ . Simi-

larly, calling  $\frac{1}{2}\Delta = 29^\circ 40'$  in equation 28, we may compute  $BQ_1 =$

$152.444$ . But from this must be *subtracted*  $M_1'M_3 = 3.946$ , which makes  $BQ_1' = 148.498$ . The actual lateral change from the original point M is equal to  $MM_2' + M_2'M_3 \sin \Delta_2 = 1.930 + 1.623 = 3.553$ . The student should verify in detail all these calculations.

**44. Field Work.** When spirals form part of the original location, it is a useless refinement to locate all the chord points before earth work has been done. It is then sufficient to locate the beginning and end of each spiral with perhaps one intermediate point in case the spiral is very long. During the resurvey which immediately precedes track work, when the roadbed is graded and flat, the intermediate points are readily inserted. Referring to Fig. 25, the point Q (or TS) would first be located at a distance VQ (see equation 25) from the point V. Assume, as in Fig. 25, a simple curve,  $6^\circ$ , with  $\Delta=32^\circ$ , and at each end a spiral 240 feet long. During the first location of the road it would be sufficient to locate the end of the spiral at point Z or SC. The deflection from the tangent when the instrument is at TS and is "sighting at" SC is  $\frac{1}{3}\phi = \frac{1}{3}$   $\left(\frac{DL}{200}\right) = \frac{1}{3}\left(\frac{6 \times 240}{200}\right) = 2^\circ .4 = 2^\circ 24'$ . The ordinate X (QK in Fig. 25) is 239.623 and the distance out from the tangent  $KZ=y=10.042$ . The total central angle to this point ( $\phi$ ) =  $7^\circ 24'$ . The central angle left between Z and Z' =  $32^\circ - (2 \times 7^\circ 24') = 17^\circ 12'$ . Set up the instrument at Z. The deflection from the tangent at the point occupied when the instrument is at Z (which is here SC) and is sighting at Q or TS is  $B = \frac{2}{3}\phi = 4^\circ 48'$ . Setting off that deflection on the transit so that when the instrument is turned around to the tangent it shall read  $0^\circ$ , the remaining central angle of  $17^\circ 12'$  can be laid off in the usual manner. Again setting up the instrument at Z' (which is point CS of that spiral) the point Q' or ST is located with the same deflection ( $4^\circ 48'$ ) as the back sight from Z to Q. The distance from Z' to the tangent VQ' is likewise the same as  $ZK=10.042$ .

When the intermediate points are to be located, the transit is set up at Q and the points are located by chord lengths of 24 feet and with deflections to the various points as given by multiplying  $a_1$  (which =  $6 \times .24 = 1.44$  minutes of arc) by the factors in the column under TS. When the circular curve ZZ' has been located and the transit set up at Z' and oriented so that it will read  $0^\circ$  when sighting along the tangent to the curve at Z', then (using the deflection factors in the column under SC) the deflection to the point 9, 24 feet away, is  $29 \times 1.44' = 41.76'$ ; to the next point 8 it is  $56 \times$

$1.44' = 80.64' = 1^\circ 20.64'$ ; the points 7, 6, etc. are found similarly; to the point of tangency Q it is  $200 \times 1.44' = 288' = 4^\circ 48'$ , as given before. Then the transit should be set up at Q' and back-sighted on Z' with a reading of  $2^\circ 24'$ . If the vertex of the curve V had already been previously located and the field work is accurate, the sighting on V should be  $0^\circ$ . Also the reading on any other point of the spiral may be computed from the column of coefficients under TS.

It sometimes becomes necessary to set up the transit at some intermediate point of the spiral, as the point 3. With the instrument set up at 3, use the coefficients under the column 3 in the table, orienting the transit by a sighting at any known point with the transit set at the given deflection for that point. Then, when the telescope is turned to  $0^\circ$ , the transit will be sighting along the tangent to the curve at the point 3 and the deflection to any other point, forward or backward, will be as given in that column by the coefficient times  $a_1$ .

It may be noted that the deflections are given to fractions of a minute of arc, which is of course very much closer than an ordinary transit can be used. But the location of spirals demands the closest work attainable with the ordinary field transit; and even though the transit is only graduated to single minutes, a fraction of a minute can be estimated when setting the vernier of a good transit and therefore the precise angles are given so that the closest attainable value of the true angle may be set off.

### VERTICAL CURVES.

**45. Reasons for Use.** Although the change of direction of motion due to a change of grade is never as great as that of an ordinary horizontal curve, yet it is as necessary in one case as in the other to join the two grade lines by a "vertical curve." As in the case of horizontal curves, there is nothing which absolutely determines the rate of curvature. When the grades intersect over a summit a comparatively short curve is permissible, but when passing through a sag the upward bend of the track acts as a literal obstruction and therefore a much longer curve is necessary. Some roads adopt some uniform distance, such as 200 feet each side of the vertex, as the length of all such curves, regardless of the change in the rate of grade. A more logical method is to

make the length a function of the change of grade. A very common rule is to make the length 100 feet for each tenth of one per cent of change of grade. For example, a one per cent grade descending into a hollow is followed by a 1.2 per cent grade climbing out of it; what should be the length of the vertical curve at the sag? The *change* of grade is the numerical sum of the grades or 2.2 per cent; therefore, by the above rule the length should be 2,200 feet. Such a length is excessive, but such a change of grade is also somewhat unusual and hardly to be found where the speed was high. For lower speed such a long vertical curve is not essential.

**46. Geometrical Form of the Curve.** The method of laying out such a curve is illustrated in Fig. 29, in which the grades are exaggerated enormously. The curve begins and ends at equal

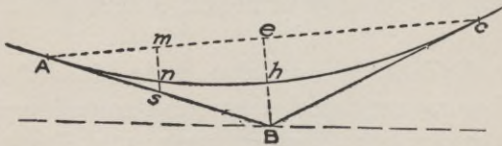

Fig. 29.

distances on each side of the vertex B, as at A and C. In the figure join A and C; bisect AC at *e*, join B and *e* and bisect Be at *h*. It may be proved

mathematically that a parabola may be passed through *h* and tangent to AB and BC at A and C, and also that at *any* point, as at *n*, the distance to the tangent (*sn*) is proportional to the *square* of the distance from A. Expressing this statement algebraically, we have

$$sn = eh \frac{(Am)^2}{(Ae)^2} \quad (36)$$

But since, in any given case *eh* is a constant and  $(Ae)^2$  is a constant, we may say for any one curve that the correction from the straight grade line to the curve equals a *constant* times the square of the distance from one end of the curve.

**47. Numerical Example.** Assume that the intersection of the grades B comes at Sta. 15 + 40; that the grade AB is - 0.6 per cent and the grade of BC is + 0.8 per cent. Then if we adopt the rule of 100 feet for each tenth per cent of change, the curve must be 1,400 feet long, must begin at Sta. 8 + 40 and extend to Sta. 22 + 40. Assume that the elevation of B is



152.50; then the elevation of A is  $152.50 + (7 \times 0.6) = 156.7$ . Similarly the elevation of C is computed as 158.1. Then the elevation of  $e$  is the mean of these two, or 157.4.  $Be$  is therefore  $= 4.9$  and  $eh = 2.45$ . Then  $eh \div (\Delta e)^2 = 2.45 \div 490000 = .000005$ , the constant which is to be multiplied by the square of the distance from A to obtain the correction from the straight grade up to the curve. The elevations of the several stations is most readily calculated in a tabular form such as is given below.

## A. STATION

8 + 40, elev.	$= 152.50 + (7 \times 0.6)$	$= 156.70$
9	$= 156.70 - (0.6 \times 0.6) + .000005 \times 60^2$	$= 156.36$
10	$= 156.70 - (1.6 \times 0.6) + .000005 \times 160^2$	$= 155.87$
11	$= 156.70 - (2.6 \times 0.6) + .000005 \times 260^2$	$= 155.48$
12	$= 156.70 - (3.6 \times 0.6) + .000005 \times 360^2$	$= 155.19$
13	$= 156.70 - (4.6 \times 0.6) + .000005 \times 460^2$	$= 155.00$
14	$= 156.70 - (5.6 \times 0.6) + .000005 \times 560^2$	$= 154.91$
15	$= 156.70 - (6.6 \times 0.6) + .000005 \times 660^2$	$= 154.92$

## B. STATION

15 + 40, elev.	$= 152.50 + 2.45$	$= 154.95$
16	$= 158.10 - (6.4 \times 0.8) + .000005 \times 640^2$	$= 155.03$
17	$= 158.10 - (5.4 \times 0.8) + .000005 \times 540^2$	$= 155.24$
18	$= 158.10 - (4.4 \times 0.8) + .000005 \times 440^2$	$= 155.55$
19	$= 158.10 - (3.4 \times 0.8) + .000005 \times 340^2$	$= 155.96$
20	$= 158.10 - (2.4 \times 0.8) + .000005 \times 240^2$	$= 156.47$
21	$= 158.10 - (1.4 \times 0.8) + .000005 \times 140^2$	$= 157.08$
22	$= 158.10 - (0.4 \times 0.8) + .000005 \times 40^2$	$= 157.89$

## C. STATION

22 + 40, elev.	$= 152.50 + (7 \times 0.8)$	$= 158.10$
----------------	-----------------------------	------------

In special cases it may be more convenient to note that at one-quarter of the distance from A to B the correction is  $\frac{1}{8}$  of  $eh$ , at one-half the distance it is  $\frac{1}{4}$  of  $eh$  and at three-fourths of the distance it is  $\frac{9}{8}$  of  $eh$ .

## CONSTRUCTION—EARTHWORK.

**48. Slopes and Cross-sections.** The construction of a road-bed of sufficient width which is level or nearly so, implies in general cuts and fills of various depths. An essential feature of the

work is that the slopes shall be such that the banks shall not give way and disintegrate, filling up the the cuts and narrowing the tops of the fills. The rate of slope is always indicated by a ratio of which the first number indicates the horizontal distance and the

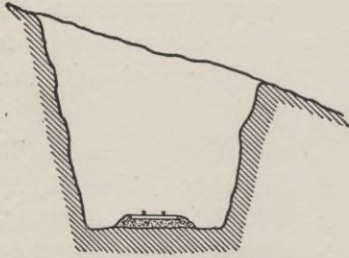

Fig. 30.

second the vertical. Frequently the second number is made uniformly *one* and then the first may be a fraction or a compound number. The following slope ratios will be so indicated. The rate of slope is variable, depending on the kind of soil. When a rock cut is very hard and firm, a vertical slope may be used, although on account of seams in the rock which make

slipping possible after the rock has begun to disintegrate, the rock is generally taken out until the slope will average more nearly one-fourth horizontal to one vertical. As the character of the material changes from rock to earth, the slope ratio for cut must be flattened until for good, firm, loamy soil a slope of 1:1 is proper. When first excavated earth will stand at a much steeper slope than this, but the

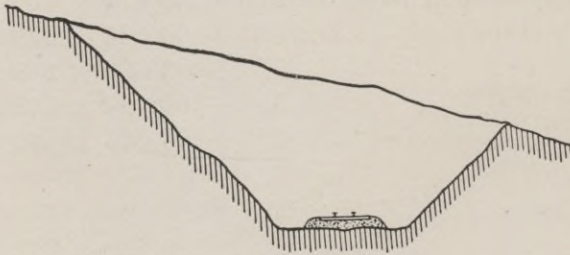

Fig. 31.

first hard rainstorm will start the disintegration which will proceed until the slope becomes about 1:1. And as it is generally cheaper to make the required excavation during the original construction, the proper slopes should be made then. Some kinds of earthy soil, such as quicksand, require even flatter slopes. Cases have been known where a cut has not ceased to slip until it had assumed a slope of about 4:1. The proper slope for a fill composed of loose

rock, as it is blasted from an excavation, is about 1:1, but when the side hill is so steep that the slope would be very long, a much steeper slope may be tolerated if some care is taken to form the stones of the fill into a rough dry wall. A fill of earth usually requires a slope of 1.5 : 1. If the material of which the fill is made is exceptionally soft, such as would require a very flat slope in cut, then a correspondingly flatter slope should be made with the fills, but in such a case it is quite possible that it would be preferable to "waste" such treacherous soil and make the fill of more suitable soil, even if it had to be "borrowed." The following illustrations will show some typical cross-sections in various kinds of soil.

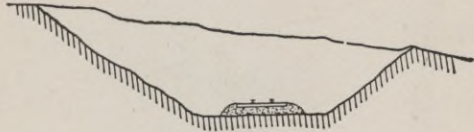

Fig. 32.

**49. Width of Roadbed.** A mistaken effort at economy will often be the excuse for cutting down the width of roadbed to such an amount that there is no room for adequate ditches in cuts, and the deterioration of the track due to lack of drainage is a very serious quantity. Even fills are sometimes made so narrow that the inevitable washing due to occasional heavy rains will endanger the stability of the track. A study of the standard roadbed cross-

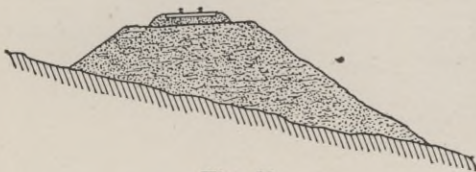

Fig. 33.

sections adopted by the principal railroads of the country shows that the average width for an earthwork cut for single track is about 25 feet.

This includes about four or five feet on each side for a ditch. For double track this width is increased by about 13 feet, the usual width between track centers for two tracks. The average width for the top of a single track fill is a little over 17 feet. Sixteen feet is about the minimum for good construction.

**50. Constructive Details—Ditches.** A well-known railroad engineer used to say that ditches were more important than ballast. A lack of good ditching will ruin a roadbed in spite of the best

ballast, while a comparatively small expenditure in ditching will largely compensate on a cheap road for the lack of good ballast. The bottom of the ditch should be from one to two feet below the bottom of the ties. The slope of the sides should not be steeper than 1:1 unless in solid rock. The bottom should be one to two

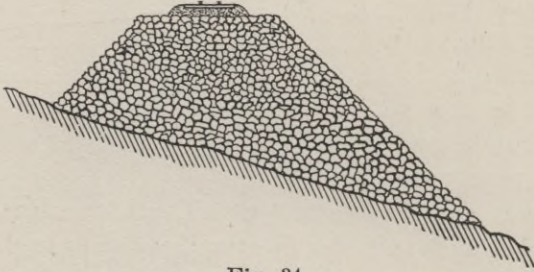

Fig. 34.

feet wide. Sometimes they are made V-shaped, but that shape is hydraulically bad and the bottom quickly fills up. *Sub-grade.* The upper surface of the earthwork, commonly called sub-grade, is usually made a level plane, but it is preferable to make two sloping planes having a crown at the center of about six inches. Rolling the sub-grade with a road roller before placing the ballast has been specified by the N. Y. Central R.R. When this is done, the water that runs through the ballast will more readily run off to the side ditches instead of soaking into the sub-soil. If the vegetable mould, which is usually found on the surface and which

is the first of the excavation for cuts, is laid on one side instead of being placed at the bottom of the nearest fill and is afterward spread on the faces of the slopes of the cuts and fills, a growth of vegetation will quickly start

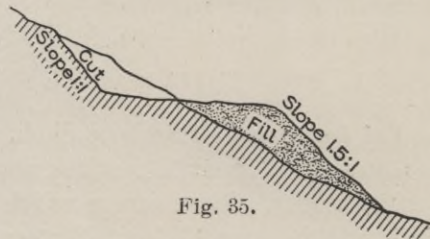

Fig. 35.

up which will save the slopes from the effects of rain washing and will quickly repay the slight additional expense. Even an immediate sodding of the slopes during construction, although it will add considerably to the original cost, will usually save much more

than its cost by a reduction of maintenance charges during the first few years.

### EARTHWORK—SURVEYS.

**51. Nature of the Problem.** The mass of earthwork which is removed has an exceedingly irregular form. The surveys have the double object of staking out the limits of the earth to be removed and placed elsewhere and also of computing the volume of that earthwork. The computation of any volume means the computation of some geometrical form or combination of forms which are assumed to represent with sufficient accuracy the actual volume under consideration. If an approximate result is sufficiently close, some simple geometrical form, easily measured and easily computed, will be selected as representing the volume. But as greater accuracy is required, the more complicated must be the form. Some of the faces of the volume are simple and determinate. Sections are usually taken 100 feet apart and perhaps closer if the ground is very irregular. Such sections are plane surfaces. The side slopes are also plane surfaces. But the side representing the surface of the earth is actually rough and irregular; usually it is too irregular to be considered a plane even approximately. The surface line of each end section is considered as a broken line of one or more parts, and it is generally assumed that plane or warped surfaces connecting corresponding lines in the end sections will lie sufficiently close to the actual surface so that the error involved will be within the desired limits. It may thus be seen that the accuracy of the computation depends not only on the accuracy of the mere numerical work but even more on the judgment used by the surveyor in so selecting the places for the cross-sections and the points of any cross-section that the geometrical form assumed to represent the volume shall agree with the actual volume of earth as closely as desired. The survey therefore consists first in determining at each section the points where the side slopes intersect the surface and then the elevation and distance from the center of points so chosen that straight lines joining these points will lie very nearly in the surface of the ground.

**52. Position of Slope Stakes.** The slope stakes are set where the side slopes intersect the surface. As seen by the fig-

ure, these intersections depend on the elevation of the roadbed, which in turn depends on the depth of cut or fill. In Fig. 36 it may readily be seen that

$$\begin{aligned} x_1 &= \frac{1}{2}b + s(d + y_1) \\ x_r &= \frac{1}{2}b + s(d - y_r) \end{aligned} \quad (37)$$

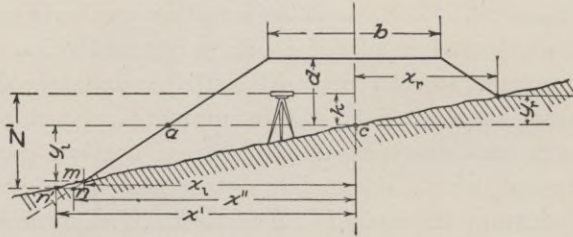

Fig. 36.

in which  $s$  is the slope ratio of the side slopes, horizontal to vertical. See §48.

Similarly it is seen in Fig. 37 that

$$\begin{aligned} x_1 &= \frac{1}{2}b + s(d - y_1) \\ x_r &= \frac{1}{2}b + s(d + y_r) \end{aligned} \quad (38)$$

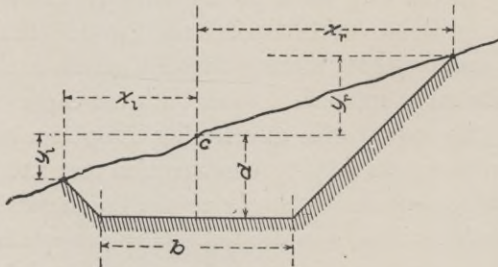

Fig. 37.

But in each of these equations, both  $x$  and  $y$  are unknown quantities, and it is impracticable to depend on a strictly mathematical solution. The simplest method is to find by trial the location of points which will satisfy the equations. An experienced man will

sometimes determine such a point in a single trial and generally the second trial will be sufficient. As a first approximation, we may note that  $a$  is at such a position that its  $x$  is  $ac = \frac{1}{2}b + sd$ .

The added distance out to  $m$  equals the added drop times  $s$ . Assume that in Fig. 36,  $d = 7.7$ ,  $b = 20$  and  $s = 1.5 : 1$ . The distance  $ac = 10 + (1.5 \times 7.7) = 21.55$ . But experience will suggest that the required point  $m$  is *about* 8 feet lower down and therefore about  $(1.5 \times 8)$  or 12 feet further out. As a first trial with the rod, the rod is placed at  $n'$ , 34 feet out ( $21.55 +$  about 12), where a rod reading of  $z'$  ( $= 10.6$ ) is found. Subtracting  $k$  ( $= 3.5$ ) we have 7.1, the " $y$ " of that point. Substituting this value of  $y$  in the first part of equation 37, we compute  $x_1$  to be 32.2. This is the point  $n$  in Fig. 36, at a distance  $x''$  (which is less than  $x'$ ) from the center. This shows that even 32.2 is too far out. Another trial is made at 30.2 feet, where the rod reading is found to be 9.3, which means that the  $y$  is  $9.3 - 3.5 = 5.8$ , which substituted in the equation gives  $x = 30.25$ . This checks so closely with 30.2, that it may be considered satisfactory. On rough ground it is an utterly useless refinement to attempt to do work closer than the nearest tenth of a foot, for the almost unavoidable inaccuracies will often have a greater effect than a change of even a tenth in such work. The above explanation is given in detail so as to show the method. Some such method is necessary for the inexperienced man, but even a short experience will enable a man to estimate the correction to his first trial very quickly and surely so that the second trial will be satisfactory, and without a detailed solution as above of all the work.

In Figs. 36 and 37, the ground has been shown as having a practically uniform slope. The determination of the slope stake is not affected essentially by the nature of the ground between the center and the slope stakes. In Fig. 42 is shown a more complicated cross-section in which the elevation of each intermediate point above the roadbed and its distance from the center must be measured. These are determined by setting up the level so that it is higher than any point in the cross-section and noting its height above the stake at the center. This rod reading added to the given center cut  $d$  gives the height of the instrument above

the roadbed. This is called the H.I. Subtracting the rod reading for any point from the H.I. gives the height of that point above the roadbed. In the case of a fill, which may be illustrated by turning Fig. 42 upside down, the level may be either above or below the roadbed. This modifies the above rule somewhat, but the same principle applies—determine the difference of elevation of each point of the surface of the ground and the roadbed.

### COMPUTING THE VOLUME.

**53. Common Methods.** Sometimes an approximate computation of the volume of the earthwork is made from the work of the preliminary survey, so as to get an approximate idea of the amount of earthwork on a route, and therefore its cost. To do this, a more or less approximate measure of each cross-section is taken and then the distance between any two cross-sections is multiplied by the half-sum of the two areas. The sum of all such products gives the total volume. Such a method is mathematically inaccurate, but the approximation in the cross-sectional areas, and some other reasons, will probably introduce still further inaccuracies. These various methods will be described in the order of increasing accuracy.

**54. Level Sections.** From Fig. 38 may readily be derived the equation

$$\text{Area} = (a + d)^2 s - \frac{ab}{2} \quad (39)$$

If  $A_0$  is the area of the initial section and  $A_1, A_2, \dots, A_n$  be the areas of the succeeding and final sections, which are at a uniform distance apart of  $l$ , then the total volume will be

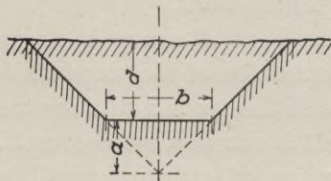

Fig. 38.

$$\text{Volume} = \frac{1}{2} l [A_0 + 2(A_1 + A_2 + \dots + A_{n-1}) + A_n] \quad (40)$$

Of course  $l$  is usually 100. The  $\frac{ab}{2}$  for each section is a constant, and therefore the subtractive term is simply this constant multi-



plied by the number of times the areas are used in the summation.

*Example.* Given the center heights set down in the second column of the tabular form. Width of roadbed, 20 feet; slope, 1.5 : 1. Then  $d = 6.7$ . The remainder of the solution is evident.

Sta.	Center Height.	(a + d)	(a + d) <sup>2</sup>	(a + d) <sup>2</sup> s	
42	1.4	8.1	65.61	98.41	} × 2 = $\begin{pmatrix} 98.41 \\ 259.46 \\ 363.00 \\ 730.08 \\ 144.06 \end{pmatrix}$
43	2.6	9.3	86.49	129.73	
44	4.3	11.0	121.00	181.50	
45	8.9	15.6	243.36	365.04	
46	3.1	9.8	96.04	144.06	

1595.01

$$\frac{ab}{2} = \frac{6.7 \times 20}{2} = 67$$

$$8 \times 67 = \frac{536}{1059.01}$$

$$\frac{1059 \times 100}{2 \times 27} = 1961 \text{ cubic yards.}$$

The above method invariably gives results which are somewhat too high, for the volume between two "level sections" is less than the length times the mean of the areas. When the areas are equal, the error is zero, but it increases as the *square* of the difference of the center cuts, or fills. But since sections are almost never truly level, the assumption that they are level will usually introduce an error largely in excess of the theoretical error. Sometimes the above method is used, aided perhaps by tables, by taking center cuts, or fills, from a profile and assuming that the actual volume will be the equivalent of the volume computed as above. Such a method has its value as a means of comparing two routes, but the error is apt to be very great.

**55. Equivalent Sections.** The following method is sometimes used when the cross-sections are irregular and especially when there is disinclination or inability to use a more accurate method. Each cross-section is plotted on cross-section paper. Then a thread ( $mn$ ) is so laid that (by estimation) it equalizes the spaces above and below it (see Fig. 39). The distances out from the center of the intersections of this mean line with the side slopes are scaled from the drawing and are here called  $x_1$  and  $x_r$ . Since  $s$  is the slope ratio,  $s = x_1 \div mo = x_r \div np$ . Then the required

area equals the area  $mno$  minus the triangles  $mso$ ,  $nps$ , and the "grade triangle," which means that

$$\begin{aligned} \text{Area} &= \frac{1}{2} \left( \frac{x_1 + x_r}{s} \right) (x_1 + x_r) - \frac{x_1}{s} \cdot \frac{x_1}{2} - \frac{x_r}{s} \cdot \frac{x_r}{2} + \frac{cb}{2} \\ &= \frac{x_1 x_r}{s} - \frac{ab}{2} \end{aligned} \quad (41)$$

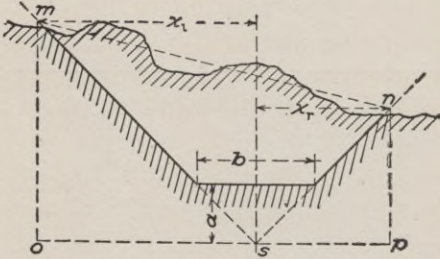

Fig. 39.

Note the simplicity of the form. When  $s = 1:1$ , the area equals the mere product of these two side distances minus the constant correction  $\frac{1}{2} ab$ . The areas being computed, the volumes are obtained exactly as in equation 40. As in the previous section, it may readily be

shown that the method of averaging end areas does not give correct results except in the special case when the distances to the right (or to the left) at adjacent stations are equal, and when these distances are nearly equal the error is small. As an approximate method, it is very rapid and good. As before, the correction is usually *negative*, *i.e.*, the computed volume is too large.

#### 56. Volume of a Prismoid.

Fig. 40 represents in a perspective view a prismoid, formed between two triangles which lie in parallel planes. The surfaces which join the corresponding sides of the triangles are, in general, warped surfaces. It may be proved that the volume of such a prismoid equals

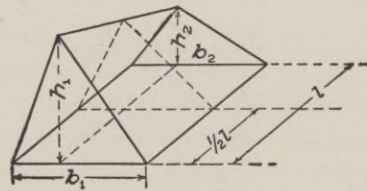

Fig. 40.

one-sixth of the perpendicular distance between the parallel planes times the sum of the two end triangles and four times the middle triangle (cut by a plane parallel to the end planes and midway between them). This may be stated algebraically as follows:

$$\text{Volume} = \frac{\text{length}}{6} (A_1 + 4A_m + A_2) \quad (42)$$

It may also be proved that the formula holds good regardless of the values, relative or absolute, of  $b_1$ ,  $b_2$ ,  $h_1$  or  $h_2$ . Therefore it holds good when  $h_2 = 0$ , and the prismoid becomes a wedge. It also holds good when both  $h_1$  and  $h_2$  become zero and the prismoid becomes a pyramid. But since the formula holds good for all these forms individually it holds good for them collectively, and since any prismoid, having bases of straight lines lying in parallel planes and with plane or warped surfaces connecting those ends, can be considered as made up of a collection of triangular prismoids, pyramids and wedges, the formula evidently holds for such a prismoid.

If, in equation 42,  $A_m$  were the mean of  $A_1$  and  $A_2$ , then we could obtain the true volume by averaging end areas. Some of the exceptional cases where this is true have already been mentioned. In general it is a complicated and impracticable problem to compute the area of the middle section. But it is quite possible to compute the correction which must be applied to the result found by averaging end areas, and these methods will be used in the following more accurate solutions. Applying equation 42 to Fig. 40, we have

$$\text{Volume} = \frac{l}{6} \left[ \frac{1}{2} b_1 h_1 + 4 \left( \frac{1}{2} \frac{b_1 + b_2}{2} \frac{h_1 + h_2}{2} \right) + \frac{1}{2} b_2 h_2 \right]$$

But the approximate volume, computed by averaging end areas, is

$$\text{Appr. vol.} = \frac{l}{2} \left( \frac{1}{2} b_1 h_1 + \frac{1}{2} b_2 h_2 \right)$$

Subtracting the approximate volume from the true volume, we obtain the

$$\text{Correction} = \frac{l}{12} \left[ (b_1 - b_2)(h_2 - h_1) \right] \quad (43)$$

**57. Three-Level Sections.** When the ground is fairly uniform so that it may be said without great inaccuracy that it slopes uniformly from the center to each slope stake, then the volume may be computed from the positions of these three points and the sections are called "three-level sections." The area of such a

section  $= \frac{1}{2}(a + d)w - \frac{1}{2}ab$ . If we consider two such adjacent sections and compute the volume by the method of averaging end areas, we will obtain as the volume

$$\text{Vol.} = \frac{l}{4} \left[ (a + d')w' - ab + (a + d'')w'' - ab \right]$$

Dividing by 27 to reduce immediately to cubic yards, we have when  $l = 100$ ,

$$\text{Vol.} = \frac{25}{27}(a + d')w' - \frac{25}{27}ab + \frac{25}{27}(a + d'')w'' - \frac{25}{27}ab \quad (44)$$

When it is desired to make the computation still more accurate, the prismoidal correction may be computed as follows. We may

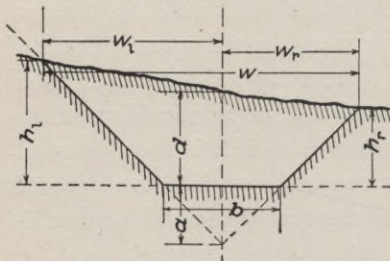

Fig. 41.

compute separately the prismoidal correction for each of the two triangular prismoids. These two prismoids together include the triangular "grade prismoid" under the roadbed, but since there is no prismoidal correction to the grade prismoid, such correction as may be computed applies solely to the volume actually

excavated. Applying equation 43 to the dimensions in Fig. 41, we have for the left side

$$\text{Pris. Corr.} = \frac{l}{12} \left[ (a + d') - (a + d'') \right] (w_1'' - w_1'), \text{ which}$$

$$\text{reduces to} = \frac{l}{12} (d' - d'') (w_1'' - w_1')$$

For the right side, we may compute similarly

$$\text{Pris. Corr.} = \frac{l}{12} (d' - d'') (w_r'' - w_r')$$

For the two triangles we have

$$\begin{aligned} \text{Pris. Corr.} &= \frac{l}{12} (d' - d'') \left[ (w_1'' + w_r'') - (w_1' + w_r') \right] \\ &= \frac{l}{12} (d' - d'') (w'' - w') \end{aligned}$$

Making  $l = 100$  and dividing by 27 to reduce to cubic yards we have

$$\text{Pris. Corr.} = \frac{25}{81} (d' - d'') (w'' - w) \quad (45)$$

An inspection of equation 45 will show that if either the center cuts or the total widths at two adjacent sections are equal or nearly so, the prismoidal correction is zero or is so small that it may be neglected. This frequently enables one to decide that the prismoidal correction will evidently be so small that it will be useless to compute its exact value. It usually happens that when  $d' > d''$ ,  $w'$  is also greater than  $w''$ . This means that the correction computed from equation 45 will usually be *negative*, which means that for three-level sections the results computed by averaging end areas will usually be too large.

A very great economy of time and accuracy result from tabulating all the computations in earthwork. Such work can be readily reviewed to check it or to discover a supposed error. An illustration of such a solution is given below.

### 58. Numerical Example.

Sta.	Center.	Left.	Right.	a + d	w	Yards.		d' - d''	w'' - w'	Pris. corr.
52	3.1 C	9.6 C	1.2 C	11.1	40.2	413				
		26.4	13.8							
53	6.7 C	11.4 C	4.2 C	14.7	47.4	645	702	-3.6	+ 7.2	- 8
		29.1	18.3							
54	10.6 C	15.6 C	7.8 C	18.6	59.1	1018	1307	-3.9	+11.7	-14
		35.4	23.7							
+ 65	15.5 C	19.0 C	10.6 C	23.5	68.4	1488	1397	-4.9	+ 9.3	- 9
		40.5	27.9							
55	8.7 C	12.4 C	5.8 C	16.7	51.3	793	674	+6.8	-17.1	-13
		30.6	20.7							

Roadbed 24' wide in cut. Approx. vol. = 4080                      -44

Slope 1.5 : 1.                      Pris. corr. = -44

$$a = \frac{b}{2s} = \frac{24}{3} = 8.0 \quad \text{True vol.} = 4041$$

$$\frac{25}{27} ab = 178$$

In the above form,  $\frac{9.6C}{26.4}$  in the third column means that the slope stake on the *left* side of Sta. 52 is 9.6 feet above the elevation of

the roadbed which is here in *cut C*; also that it is 26.4 feet out from the center. This notation is also used to indicate the position of "intermediate points," the numerator of the fraction giving the depth of cut or fill (C or F) and the denominator the distance from the center. The other points in the third and fourth columns are to be interpreted similarly. Column 5 is found by adding  $a$  ( $=8.0$ ) to column 2;  $w$  in each case is the sum of the two denominators in the same horizontal line; 413 (in column 6)  $= \frac{25}{27} \times 11.1 \times 40.2$ . A short method of performing this multiplication will be given later. The solution of equation 44 applied to this case is:

$$\text{Vol.} = 413 - 178 + 645 - 178 = 702.$$

$$\text{Similarly } 1397 = \frac{65}{100} (1018 - 178 + 1488 - 178).$$

$$\text{and } 674 = \frac{35}{100} (1488 - 178 + 793 - 178).$$

$$- 3.6 = 3.1 - 6.7 \quad \text{and} \quad + 7.2 = 47.4 - 40.2. \quad - 8 = \frac{25}{81}$$

$(- 3.6) \times (+ 7.2)$ ; see equation 45. Note that in this case the prismoidal correction is about 1 per cent of the total volume. The errors due to inaccurate cross-sectioning will frequently be more than this. The volume 4036 cubic yards is the *precise* volume (barring the neglect of the fraction of a yard) of the prismoids given by the notes. Whether these prismoids actually represent the true volume of the earthwork depends entirely on the cross-sectioning and is entirely out of the hands of the computer.

**59. Computation of Products.** The products  $\frac{25}{27} ab$  may be written  $\frac{ab}{1.08}$ . These products are always the combination of two variable terms and a constant. It thus becomes possible to construct tables which will give these products for any given height and width. Crandall's Earthwork Tables are computed on this basis. But these products are also obtained with great ease by means of a slide rule, provided it is large enough to give the required accuracy. The 108 mark, being so constantly in use should have a special mark so that it may be found without effort.

As a numerical illustration, take the first of the above cases. Set the 108 mark of the upper scale on the 111 mark on the lower scale. Then look for the 402 mark on the upper scale and note that it is nearly over the 413 mark on the lower scale. While it is possible to devise set rules to determine the position of the decimal point, it is considered that a hasty mental solution of the problem will decide the point quicker and with less chance of error. For example—the product of the two variable quantities is always divided by 1.08, which means that the final result will be a little less than the simple product of the two variables,  $11 \times 40 = 440$ . Therefore 413 is evidently the correct result, rather than 41.3 or 4130. The products  $\frac{25}{81} xy$  are similarly obtained since  $\frac{25}{81} = \frac{1}{3.24}$ , and the 324 mark can be used instead of the 108. For example, the slide rule shows that  $\frac{(-3.6) \times (+7.2)}{3.24} = -8$  to the nearest cubic yard. As to the decimal point— $3.6 \div 3.24$  is something more than one; therefore, the result is something more than 7.2. Therefore it is 8, rather than 80 or 0.8. If the student has neither tables nor slide rule, the multiplication of the two variables (in columns 5 and 6) and the division of the products by the constant 1.08, may be made so mechanical and systematic that it may be done quickly and accurately—although it is much slower than the slide rule method.

**60. Irregular Sections.** The distance from the center and the height above or below the roadbed must be obtained for each break in the surface between the slope stakes. Then, in Fig. 42, by dropping perpendiculars from each point to the roadbed line, the total area is divided into a number of trapezoids, the sum of the areas of which (less the areas of the two triangles under the side slopes) equals the total area of the section. For Fig. 42, the area would be stated algebraically as follows:

$$\begin{aligned} \text{Area} = & \frac{1}{2}(r+s)(f-g) + \frac{1}{2}(s+t)(g-h) + \frac{1}{2}(t+d)h \\ & + \frac{1}{2}(d+v)j + \frac{1}{2}(v+w)(k-j) - \frac{1}{2}w(k - \frac{1}{2}b) \\ & - \frac{1}{2}r(f - \frac{1}{2}b). \end{aligned}$$

Expanding this and collecting terms, of which many will cancel out, we have

$$\text{Area} = \frac{1}{2} \left[ fs + g(t-r) + h(d-s) + kv + j(d-w) + \frac{1}{2} b(r+w) \right]. \quad (46)$$

Although the above equation looks as if it applied only to the particular case given, yet a little study of it will show that the terms follow a law so general that the *reduced* equation for the area of *any* section, no matter how complicated or how many points it may have, may be written out by a literal obedience of the following rule:

*Area equals one-half the sum of products obtained as follows:*

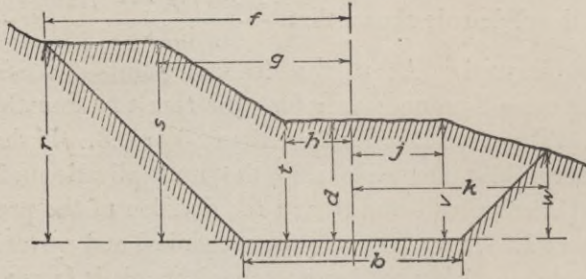

Fig. 42.

*The distance to each slope stake times the height above grade of the point next inside the slope stake;*

*The distance to each intermediate point in turn times the height of the point just inside minus the height of the point just outside;*

*Finally, one-half the width of the roadbed times the sum of the slope stake heights.*

The above rule may be followed literally whether there are forty intermediate points or one, or even *none*. When there are no intermediate points the terms for that side reduce to one—the distance to the slope stake times the height of the point next inside (which in this case is the center). For three-level ground (see Fig. 41), we would have three terms;





END OF TUBE-SECTION FOR RAILROAD TUNNEL UNDER DETROIT RIVER  
View showing bulkheads. Tubes to be sunk to desired level.



Area =  $w_1 d + w_r d + \frac{1}{2} b (h_1 + h_r)$ , which reduces to two terms

$$\text{Area} = wd + \frac{1}{2} b (h_1 + h_r).$$

The method of § 57 has the advantage that one of the two terms for each section is constant for all sections—in the numerical case of § 58 it is 178 cubic yards. By the above method the two terms for each section are variable. Nevertheless, when the cross sections usually have one or more intermediate points and therefore the method of § 60 must be used, and an occasional section is found with no intermediate points, it is better for the sake of uniformity to apply the above method rigidly and thereby avoid the possible confusion and error that would result by the use of another method. Probably no time would be saved by the change of method.

**61. Prismoidal Correction.** The above method of irregular sections is capable of being followed to its logical conclusion, and a computation for volume made which is mathematically correct, provided that it is noted on the ground how the points of adjacent sections are joined, so that the warped surfaces thereby developed shall lie as closely as possible in the actual surface of the ground. But the very fact that the cross-section is irregular implies that any longitudinal section will be correspondingly irregular, and this leads to the suspicion that a refinement in the computations may be overshadowed by a much larger but unknown difference between the volume of the assumed geometrical solid and the actual volume of the earthwork. In order to obtain a correction which is easily computed and which gives a result which is probably much nearer the truth than no correction at all, the following method is much used: Consider that *for the purpose of the correction* the ground is “three-level ground” and use equation 45. Numerical computations of volumes by both methods have shown that the *difference* is small, and is perhaps smaller than the probable error on the entire work. This method will be used in the following numerical solution:

**62. Numerical Example. Volume of Earthwork in Irregular Ground.** The first tabular form gives a desirable form of notes for recording the field work. Note that the station numbers

Sta.	Center } Cut or Fill.	Left.			Right.	
47	1.2 c	4.2 c 16.4			0.8 c 11.2	
46	4.3 c	5.1 c 17.6	6.2 c 8.5		2.1 c 3.4	1.6 c 12.4
+ 42	13.6 c	20.2 c 40.3	15.7 c 32.4	14.4 c 16.8	12.5 c 10.2	9.6 c 24.4
45	9.2 c	12.3 c 28.5	12.7 c 16.0	6.8 c 6.4	9.2 c 8.5	7.8 c 21.7
44	3.2 c	6.0 c 19.0	3.5 c 8.3			1.8 c 12.7

Roadbed 20 feet wide in cut. Slope 1.5 : 1.

FORM FOR REDUCING THE ABOVE FIELD NOTES.

Sta.	Width.	Height.	Yards.		Center height.	Total width.	$d' - d''$	$w'' - w'$	Approx. pris. corr.
44	19.0	3.5	62		3.2	31.7			
	8.3	- 2.8	- 22						
	12.7	3.2	38						
	10.	7.8	72						
45	28.5	12.7	335		9.2	50.2	- 6.0	+18.5	- 34
	16.0	- 5.5	- 81						
	6.4	- 3.5	- 21						
	21.7	9.2	185						
	8.5	1.4	11						
	10.	20.1	186	765					
+ 42	40.3	15.7	585		13.6	64.7	- 4.4	+14.5	- 20
	32.4	- 5.8	- 174						
	16.8	- 2.1	- 33						
	24.4	12.5	282						
	10.2	4.0	38						
	10.	29.8	276	667					
46	17.6	6.2	101		4.3	30.0	+9.3	- 34.7	- 100
	8.5	- 0.8	- 6						
	12.4	2.1	24						
	3.4	2.7	8						
	10.	6.7	62	675					
47	16.4	1.2	18		1.2	27.6	+3.1	- 2.4	- 2
	11.2	1.2	12						
	10.	5.0	46	265					

Approx. volume = 2372

- 156

“ pr. corr. = -156

Corrected volume = 2216 cubic yards.

run up the page. By this method the "fractions" which show the height and distance out of each point are recorded in their approximate relative position when the note book is held looking ahead along the line.

It should be noted in this case that the prismoidal correction is a large percentage of the total volume. In the case of a pyramid, the correction is one-third of the nominal volume, which means that it is 50 per cent of the true volume. The foregoing numerical case gives the notes for an embankment crossing a gully, and in such cases especially the prismoidal correction is always large and should not be neglected.

**63. Side-hill Work.** A road frequently runs along the slope of a hill so that it is necessary to have both cut and fill in the same section. The profile at such a place will indicate little or no earthwork, but if the natural slope is steep and the roadbed wide the amount of earthwork may be considerable. Although it is possible to apply the general rule of § 60 to such cases, it is usually simpler to compute the area in each case independent of the rule, especially when the section forms a mere triangle. The areas of cut and fill must be calculated independently. When a section of cut or fill is found at one station and is not found at the next, accuracy requires a knowledge of the place where the cut or fill "runs out". That small volume must then be considered a pyramid with a given base and height. In general the end of every cut or fill implies the existence, at least for a short distance, of side-hill work. Although the volumes are usually small, yet since they are frequently of pyramidal form, the prismoidal correction is usually a large percentage of the volume and hence should not be neglected. The rule of § 61 can generally be applied.

**64. Borrow Pits.** This name is applied to places from which earth is taken to make an embankment when there is insufficient excavated material in the neighborhood or when the material is unsuitable for embankments. Such volumes must be measured up and paid for the same as other excavation. Sometimes the form of the excavation is literally that of a rectangular pit, in which case the simple product of the three dimensions

gives the volume. But usually it is required to slope the sides; sometimes the material is obtained by widening a cut, as in Fig. 44. If the borrow pit is very large, several cross-sections should be taken at sufficiently close intervals. If the prismoids into

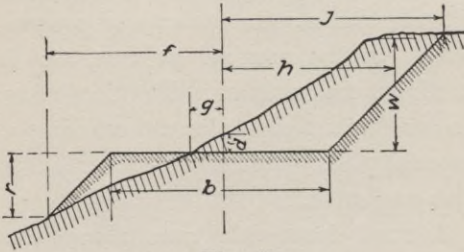

Fig. 43.

which the total volume is divided have substantially equal bases, the prismoidal correction will be small and may be neglected, but if the forms are pyramidal the correction should be computed. It may become necessary to consider the total volume as made

up of triangular prismoids and compute the prismoidal correction for each one separately.

**65. Correction for Curvature.** The volume of a solid, generated by revolving a plane area about an axis lying in the plane but outside of the area, equals the product of the given area times the length of the path of the center of gravity of the area. When the centers of gravity of the cross-sections lie in the center of the road, where the length of the road is measured, no correction is necessary. If all the cross-sections were the same and therefore had the same eccentricity, the total volume could be computed by the above rule. But in general both the areas and the eccentricities vary from point to point, and then a theoretically exact solution would be impracticable for ordinary work if not impossible. But a sufficiently practical rule can be developed as follows: Assume a curved prismoid, of uniform cross-sections

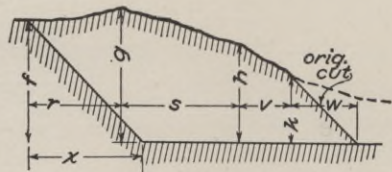

Fig. 44.

and therefore of uniform eccentricity. Call that eccentricity  $e$ . Let  $R$  be the radius of the center line of the road. Then the length of the path of the center of gravity is to the length measured on the center line as  $R \pm e : R$ . Therefore we have

$$\text{True volume} : \text{nominal volume} :: R \pm e : R$$

Therefore the true volume of the prismoid  $= lA \frac{R \pm e}{R}$ . This shows that the effect of curvature is the same as increasing or diminishing the area by an amount which depends on the area and the eccentricity and that the increased or diminished area may be found by multiplying the actual area by the ratio  $\frac{R \pm e}{R}$ . This being independent of the value of  $l$ , it is true for infinitesimal lengths. If the eccentricity is assumed to vary uniformly between two sections, the *equivalent* area of a cross-section located midway between the two end areas would be  $A_m \frac{R \pm \frac{1}{2}(e' + e'')}{R}$ . Therefore the volume of a solid which, when straight, would be  $\frac{1}{6} l (A' + 4A_m + A'')$  would then become

$$\text{True volume} = \frac{l}{6R} \left[ A' (R \pm e') + 4A_m \left[ R \pm \frac{1}{2} (e' + e'') \right] + A'' (R \pm e'') \right]$$

Subtracting the nominal volume, which is the true volume when the prismoid is straight, we have the correction for curvature as follows

$$\text{Correction} = \pm \frac{l}{6R} \left[ (A' + 2A_m) e' + (2A_m + A'') e'' \right]$$

As in the case of the prismoidal formula, the use of this equation implies a knowledge of the middle area. This correction is always a small proportion of the total volume and is frequently insignificant. Therefore no appreciable error is involved in making the equation read

$$\text{Curv. corr.} = \frac{l}{2R} (A'e' + A''e'') \quad (47)$$

**66. Eccentricity of the Center of Gravity.** *The value of "e".* The determination of the center of gravity of a complicated irregular cross-section would be a long and tedious problem and is practically unnecessary. For the purpose of this correction it is sufficiently accurate to consider all sections as three-level sections, except in side-hill work, where they should usually be considered as triangles. In Fig. 45, the eccentricity of the center of gravity

of the whole section, including the grade triangle, may be computed as follows:

$$e = \frac{\frac{(a+d)x_1}{2} \frac{x_1}{3} - \frac{(a+d)x_r}{2} \frac{x_r}{3}}{\frac{(a+d)x_1}{2} + \frac{(a+d)x_r}{2}} = \frac{1}{3} \frac{(x_1^2 - x_r^2)}{(x_1 + x_r)} = \frac{1}{3} (x_1 - x_r) \quad (48)$$

Substituting this value of  $e$  in equation 47, we have

$$\text{Curv. corr.} = \frac{l}{6R} \left[ A' (x_1' - x_r') + A'' (x_1'' - x_r'') \right]$$

But the approximate volume of a prismoid may be written

$$\text{Vol.} = \frac{l}{2} (A' + A'') = \frac{l}{2} A' + \frac{l}{2} A'' = V' + V''$$

in which  $V'$  and  $V''$  represent the number of cubic yards corresponding to the area at each station. Substituting these values in the above equation, we have

$$\text{Curv. corr. in cu. yd.} = \frac{1}{3R} \left[ V' (x_1' - x_r') + V'' (x_1'' - x_r'') \right] \quad (49)$$

The value of  $e$ , found in equation 48, is the eccentricity of the whole area, including the grade triangle under the roadbed. The eccentricity of the true area is greater than this and equals

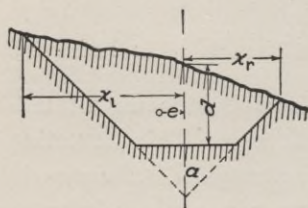

Fig. 45.

$$e^1 = e \times \frac{\text{true area} + \frac{1}{2} ab}{\text{true area}}$$

The required quantity (the  $A' e^1$  of equation 47) equals *true area*  $\times e_1$  which

equals  $(\text{true area} + \frac{1}{2} ab) \times e$ . The value of  $e$  (given in equation 48) is a remarkably simple term, while the value of  $e_1$  is very complicated and difficult to compute. But since we may obtain the true corrective value by using  $e$  and at the same time adding the yardage corresponding to the grade triangle to the yardage corresponding to each area, it is best to do it in this way.

For any one curve the corrective terms are all divided by the quantity  $3R$ . If tables are not at hand, it is amply accurate to



compute that  $R = \frac{5730}{D}$  in which  $D$  is the degree of the curve.

Even equation 49 may be simplified somewhat in actual use. The correction at each station has the form  $\frac{V(x_1 - x_r)}{3R}$ .  $3R$  is usually a large quantity; for a  $4^\circ$  curve it is 4298.  $(x_1 - x_r)$  is relatively very small. Their ratio times  $V$  is never a very large quantity, and it is frequently less than unity, when, of course, it should be ignored. An approximate solution will generally show that the product  $V(x_1 - x_r)$  is roughly twice or three times  $3R$ , or is perhaps less than one-half  $3R$ , and then the corrective term for that station may be written 3, 2, or 0 cubic yards, the fraction being ignored. It is only when the curvature is excessively sharp and the eccentricity very great that the curvature correction becomes a large percentage of the volume.

The algebraic sign of the correction is most surely and easily noted from a consideration of the direction of the curvature and on which side the earthwork predominates. If the center of gravity is evidently toward the *inside* of the curve the true volume is evidently *less* than the nominal volume and the correction should be *negative*. When the curve turns to the *right*, use the form  $(x_1 - x_r)$ ; when it turns to the *left*, use the form  $(x_r - x_1)$ . The algebraic sign of the correction will then be strictly in accordance with its true value.

**67. Numerical Example.** Assume that the earthwork computed in § 58 is located on a  $10^\circ$  curve to the *left*. How much will be the curvature correction? Copying from the solution in § 58 the necessary data we have at once the first four columns of the tabular form. Usually the last three columns will be merely added to the form given in § 58. Since the curve is to the left, we use the form  $(x_r - x_1)$ .  $3R = 3 \times 573 = 1719$ .

Station.	$x_1$	$x_r$	Yards.	$x_r - x_1$	$\frac{V(x_r - x_1)}{3R}$	Curv. corr.
52	26.4	13.8	413	-12.6	-3	
53	29.1	18.3	645	-10.8	-4	-7
54	35.4	23.7	1018	-11.7	-7	-11
+ 65	40.5	27.9	1488	-12.6	-19	-17
55	30.6	20.7	793	-9.9	-5	-8

Total curv. corr. = -43 yards.

The net volume of the mass under consideration is thus reduced to 3,998 cubic yards. A  $10^\circ$  curve is rather unusual. Since the correction varies directly as the degree of the curve, if the above curve were a  $4^\circ$  curve the correction would be only  $0.4 \times 43 = 17$  cubic yards.

**68. Eccentricity of the Center of Gravity of a Side-hill Section.** It will generally be sufficiently accurate to consider, for

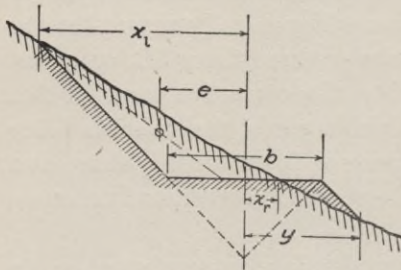

Fig. 46.

this purpose, that all side-hill sections are triangular. The center of gravity of a triangle lies on a line joining the vertex and the middle of its base, and at one-third of the length of this line from the base. The eccentricity is therefore equal the distance from the center to the middle of the base of the triangle plus one-third of the

base of the triangle plus one-third of the horizontal projection of that line. Applying this rule to Fig. 46, we have

$$\begin{aligned}
 e &= \left[ \frac{b}{2} - \frac{1}{2} \left( \frac{b}{2} \times x_r \right) \right] + \frac{1}{3} \left[ x_1 - \left( \frac{b}{2} - \frac{1}{2} \left( \frac{b}{2} + x_r \right) \right) \right] \\
 &= \frac{b}{4} - \frac{x_r}{2} + \frac{x_1}{3} - \frac{b}{12} + \frac{x_r}{6} \\
 &= \frac{b}{6} + \frac{x_1}{3} - \frac{x_r}{3} \\
 &= \frac{1}{3} \left[ \frac{b}{2} + (x_1 - x_r) \right] \tag{50}
 \end{aligned}$$

It should be noted that the grade triangle is not considered in the above solution; therefore the volume of the grade prism should not be considered in applying Eq. 49. In three-level ground the curvature correction will be zero when  $x_1 = x_r$ , but in side-hill work the curvature correction is never zero and it may be a large proportion of the total volume.

In case the triangle lies wholly on one side of the center, it may be similarly shown that the equation may be written

$$e = \frac{1}{3} \left[ \frac{b}{2} + (x_1 + x_r) \right] \quad (51)$$

This equation may be derived directly from equation 50 by considering that when both points are on the same side of the center, the algebraic sign  $x_r$  should be changed. These various cases may be generalized by saying that when the triangle lies on *both* sides of the center,  $e$  is always numerically equal to  $\frac{1}{3} \left[ \frac{b}{2} + (x_1 \sim x_r) \right]$  in which the form should be  $(x_1 - x_r)$  or  $(x_r - x_1)$  according to the criterion used in § 66. When the triangle is on one side only  $e = \frac{1}{3} \left[ \frac{b}{2} + \text{the numerical sum of the two distances out} \right]$ . Its algebraic sign should be determined as in § 66.

### CONSTRUCTIVE EARTHWORK.

**69. Methods of Excavating.** Economical excavating depends largely on the distance to be hauled as well as on the character of the soil. Side-hill work is usually done by mere shoveling, the earth being loosened by picks or plows. When the distance that the earth must be moved becomes greater, wheelbarrows or drag scrapers become economical. Wheeled scrapers, two-wheeled carts, four-wheeled wagons, small cars drawn by horses, and heavier cars drawn in a train load by locomotives successively become more economical as the distance increases. As the magnitude of the work increases, thereby justifying an increase in the cost of the plant used, economy in the cost of loosening and loading is obtained by using a steam-shovel instead of picks and plows. When cuts are very deep, they are best excavated in "benches" whose height will depend on the method of loosening and loading.

**70. Blasting.** Blasting is employed not only for hard rock which can only be removed by such methods, but also as a means for rapidly loosening shale and even frozen earth. The explosives used vary in their composition from a high grade detonating explosive, such as No. 1 dynamite which consists of 75 per cent nitro-glycerine, to black powder which is, comparatively, "slow burning." Between these extremes there are a great multitude of explosive compounds, which consist of varying proportions of

explosives of the two types. It has been demonstrated that a slow burning explosive is made to "detonate" if it is exploded by means of a sufficient volume of a detonating explosive, which means that a mixture of the two kinds has a greater explosive force than the sum of the constituents exploded separately. The choice of explosive depends on the character of the rock. A hard brittle rock requires a detonating explosive which shall shatter it. A soft and tough rock is best loosened by a powder which acts more slowly. If dynamite is exploded in a soft clay rock the hole will be blown out, but the great mass of the rock is not disturbed. When the center of the mass of powder is 4 feet from the nearest surface, about 2 pounds of black powder (or about  $\frac{1}{3}$  of a pound of dynamite) should be used. The amount should vary as the *cube* of the "line of least resistance," *i.e.*, if the center of the blast is 10 feet from the nearest surface the amount would be determined by the proportion  $x : 2 :: 10^3 : 4^3$ , or  $x = 31$  pounds. In this case, since dynamite is about six times as powerful as black powder, a little over 5 pounds of No. 1 dynamite would do as well. The "line of least resistance" may not be the "nearest line to the surface" on account of seams in the rock which modify its resisting power, but the above rule is about as near a fixed rule as can be stated. For open work, especially when time is not a very important matter, it is cheaper to use black powder, but in tunnel headings where the progress of the work is limited by the progress of the drillers it is economical to use dynamite although it is more expensive.

*Drilling.* Hand drilling when the holes are vertical is best accomplished with "churn drills," which are heavy bars of iron shod with a steel drill, which are raised and dropped, the impact doing the cutting, the drill being slightly turned after each stroke. From five to fifteen feet of holes, depending on the character of the rock, is considered a fair day's work of ten hours. Oblique or horizontal holes must be drilled with light drills of the "one-man" type or the "two-man" type. The one-man drill is worked entirely by one man with a light one-hand hammer. With the other method, one man holds the drill, which is perhaps a little heavier and which is struck by another man, or perhaps by two, using a heavy hammer. It has been found that the light-hammer method is more economical for soft rocks, the heavy-hammer

method more economical for hard rocks, but that the light-hammer method is always quicker and is to be preferred when limited space and time are matters of importance. Machine drilling is a specialty which can only have a very brief general discussion here. Where the magnitude of the work will justify it, it is always more economical per foot of hole drilled. The plant is expensive both in first cost and maintenance; part of the expense is nearly constant regardless of the number of holes bored, and so it is only when the work is extensive that the method is advantageous, but under favorable circumstances the economy is very marked. For open-pit work individual drills are used, but for tunnel headings several drills are mounted on a "carriage" from which, after it is set, several holes may be drilled simultaneously. Compressed air is used to run the drills in tunnel work. This serves the additional purpose of furnishing a supply of pure cold air at the place where it is most needed.

*Tamping.* It has been found that air spaces around the explosive cause a very material reduction in the force of the explosion, therefore it is necessary to ram the explosive into a solid mass and then pack the top of the hole. Iron bars should never be used for tamping. Copper bars are sometimes used for ramming powder, but dynamite is most safely rammed with wooden bars. Clay is the best tamping material where it is available, but sand or finely powdered rock will serve very well. It has been found that when blasting under water the weight of the superincumbent water is sufficient tamping.

*Exploding.* On small-scale work, the blasts are generally exploded by means of a powder fuse, which is essentially a cord which forms the matrix for a train of powder, the cord being further protected by a wrapping of some sort. The better plan, and the one which is used almost exclusively for extensive work, is to explode a large number of holes simultaneously by means of electricity. A "cap" containing a small charge of fulminate of mercury, an expensive but very powerful explosive, is set in the midst of the larger mass of explosive. An electric current from a field battery is sent through each cap. As the current passes through each cap it heats a small platinum wire to redness or else causes a spark to jump across a short gap in the wire. In either

case the fulminate is exploded, which in turn explodes the main charge.

*Cost.* The cost of blasting is so exceedingly variable, depending on the nature of the rock, depth of the cutting, and especially on the magnitude of the work and the methods employed, that only the most approximate estimates can be here given. Under the most favorable circumstances, deep cutting, machine methods, and a rock which is brittle but not too tough, the cost may fall as low as 25 cents per cubic yard, while with hand drilling, hard and tough rock, in a shallow cut, the cost might easily rise to \$1 per cubic yard. It would indicate exceptionally unfavorable circumstances, bad management, or possibly an excessive price for common labor, if the cost should rise above this figure.

**71. Formation of Embankments.** Experience has shown that when earth is excavated and piled in embankments its volume will at first be more than the original measured volume but that it will finally shrink to about 90 per cent of its original volume. The percentage of shrinkage is a very uncertain quantity, as it depends on the kind of earth, on the method employed in forming the embankment and on the time elapsed between construction and the measurement of what is supposed to be the settled volume. Material dumped from a trestle will first have a volume considerably in excess of its final volume and it will take several months and even years to shrink to its final volume. On the other hand, if an embankment is formed in very thin layers, each of which is packed down by the process of unloading the succeeding layer, there will be but little shrinkage after the embankment is finished, but more material than the volume as measured in the cut will be required to form that volume of embankment. Broken rock, formed into an embankment, will have a volume about 80 per cent greater than the mass of solid rock from which it is taken.

It is frequently specified that embankments are to be made to a somewhat higher elevation than the plan of the road calls for, so that the expected shrinkage will reduce the embankment to the desired level. Since the contractor is paid by the cubic yards of material *excavated* and is required to dispose of excavated material as required, it is generally specified that the amount of this

excess of height of embankments is left to the discretion of the engineer who decides the question during the progress of the work and after he has had an opportunity to judge of the material after excavation is under way. When embankments are placed on side-hills, the surface should be first plowed or have trenches dug along the slope so that the embankment shall not slip down the hill. A ditch dug at the base of each slope will drain the sub-soil and may prevent a dangerous and costly disintegration of the embankment. Thickening the layers of an embankment on the outside somewhat so that the layers will be concave upward may also present sliding of the layers on each other. When the plans call for a very long and high embankment, it is sometimes best to construct first a trestle and operate the road over it. The trestle should have a life of at least five or six years, and during that time material can be brought from some excavation, perhaps several miles away, where it was perhaps loaded with a steam shovel, hauled by the train load, dumped with an "unloader," and allowed all the required time to settle, the whole being done for a cost per yard far less than it would have cost during the original construction. The method has the added advantage of permitting the road to be quickly opened for traffic and permitting it to quickly get on an earning basis, for such a trestle can be built more quickly than a very high embankment.

**72. Classification of Earthwork.** One of the most fruitful sources of legal contention between a contractor and his employer is the classification of excavated material when the work is paid for according to the classification of the material excavated. It is not only true that there is an insensible gradation from the softest of earth to the hardest of rock, but a material which is very hard when first exposed will sometimes crumble up after a very short exposure to the atmosphere. It is even true that some kinds of rock which are very soft when first taken out harden after exposure to the air, but this class of phenomena never has any influence on mere blasting for excavation. To avoid these disputes, some railroads require their contractors to satisfy themselves as to the character of the material to be excavated and then to make a single bid per yard which shall include whatever material is encountered. With all its advantages, this throws all the uncertainty on the con-

tractor, and unless the competition is very great and the bidding close the contractor will usually add so much to cover that uncertainty that the railroad will pay more than it would on a classified basis.

The classification is usually made threefold—(1) solid rock, (2) loose rock, including shale and hard-pan, and (3) earth. Solid rock includes only such material as cannot be removed except by blasting, when it is found in masses exceeding one cubic yard. Loose rock includes boulders which are more than one cubic foot in volume and less than one cubic yard; also stratified rock occurring in layers of not more than six inches, when they are separated by strata of clay; also all material (not classified as earth) which *can* be loosened with a pick and bar and which “*can* be quarried without blasting although blasting may occasionally be resorted to.” “Earth” includes all material not considered above—boulders not over one cubic foot in volume, all clay, sand, gravel, loam, decomposed rock and slate, and all materials which can be loosened for loading by a plow with two horses, or such as one picker can keep one shoveler busy. A brief consideration of the above classification, which is compiled from the best authorities available, shows the infinite opportunities for dispute as to classification.

### TUNNELS — SURVEYING.

**73. Character of Surveying.** There are few kinds of surveying for engineering work where accuracy is of such high financial value and where it is so difficult to accomplish as it is in tunnel work. By the very nature of the case a tunnel is usually located in a region where it is very rough and all the surface surveys must be made on very steep slopes where accurate measurements are exceedingly difficult. The surveys in the tunnel itself are made in cramped quarters where light is artificial and the atmosphere is perhaps smoky. The difficulties will be elaborated as the methods for obviating them are discussed. Tunnels are generally excavated from each end. A very small error at either end will accumulate, especially if the tunnel is very long, until when the two headings meet there may be an offset which might actually necessitate a small reversed curve in the alignment. Therefore only the most refined measurements for distance, the



most refined leveling between the ends of the tunneling and the repeated measurements of all horizontal angles or the most precise prolongation of lines are to be used. All such work should be repeated and checked until the probable error of the work is so small that such error as may remain has no financial importance. The cost of such refined work is amply justified, because the lack of it may result in an error whose financial value might be very great.

**74. Surface Surveys.** The relative position of the two ends of the tunnel is first determined, *i.e.*, the azimuth and length of a line joining the two ends and the relative elevation. Usually a line is run on the surface which will be at every point exactly over the center line of the tunnel. When the tunnel is perfectly straight throughout, this is comparatively easy. Any curvature in the tunnel complicates the surveying greatly. A permanent station, from which a long sight can be run into the tunnel, is placed at each end. Then intermediate permanent stations are set so that adjacent stations are intervisible. These stations are first set approximately on line and then by repeated adjustments they are all set exactly on line. Any intermediate shaft can then be located from the adjacent stations.

**Distance.** The distance is sometimes determined, as in geodetic surveying, by triangulation and the measurement of a base line. Some of the great Alpine tunnels have been measured in this way. But for simpler work a direct measurement is made with a tape. Since the slopes are usually very steep, it becomes impracticable to hold any very great length of the tape truly horizontal. It is then also necessary to plumb down from the down-hill end of the tape to the ground. This is troublesome and also introduces an element of inaccuracy. And therefore "slope measurements" are often made, measuring the slope distance between carefully marked points and at the same time determining the difference of elevation. A simple geometrical calculation then determines the true horizontal distance. These marks may consist of needles set in wooden plugs supported on ordinary surveying tripods.

**Levels.** The above method includes the leveling. But if the ordinary method of leveling is used, especial care must be taken, since the slopes are very steep and the vertical distances to be overcome very great.

**75. Underground Surveys.** Station marks, corresponding to the stakes of ordinary surveys, cannot usually be placed in the bottom of the tunnel since they would be very quickly disturbed or covered over with debris. If the tunnel is timbered, the easiest method is to place the marks on the timbering, but this should not be done unless the timbering is very firmly in place and is not liable to be shifted. The better plan is to drill a hole in the roof of the tunnel, insert a wooden plug, and then set in the wood a small hook or nail which marks the exact point. Occasionally such marks are placed on the side of the tunnel. When placed in the roof there is the advantage that a plumb line, which must be illuminated by a lantern, may be swung from the hook or nail. A still better device is a plumb bob hung by a pair of cords attached to a "gimbel joint" on the bob. The bob has a little reservoir for oil and a wick exactly in the center which will furnish a flame which may be seen as far as necessary and which may be bisected by the cross hairs of the transit with great accuracy. Such "sights" can be reproduced whenever desired with great confidence that there is no appreciable variation. When a mere plumb line is used to sight at, it must be illuminated by some sort of lantern. This may be done by using a lantern with a ground glass which is placed behind the line, which is seen by its contrast against the illuminated background. If an ordinary lantern is used, it should be placed nearly in front of the line and pointing away from the transit, so that, without being seen from the transit, it illuminates the face of the line which then shows light against the darkness of the tunnel.

The leveling must, of course, be done with the level rod inverted so as to obtain the distance from the station point *down* to the line of sight. Of course this makes a corresponding difference in the calculations which must be carefully watched to avoid a blunder due to this change. This may be avoided by always placing a minus sign before any rod readings so taken, and then following the old rule of *algebraically* adding backsights and subtracting foresights and intermediate sights. Various devices are required to meet special conditions which test the inventive ingenuity of the engineer.





**"DOUBLE BOW KNOT" ON RAILROAD UP MOUNT TAMALPAIS, CALIFORNIA**

About 15 miles north of San Francisco. The line here parallels itself five times within a distance of 400 feet across tracks. This "most crooked railroad in the world," in a distance of  $8\frac{1}{2}$  miles, overcomes a grade of 2,592 feet, making 281 curves, which, if continuous, would make 42 complete circles. The locomotives used are oil-burners of the "marine-g geared" type, with three vertical cylinders on one side operating the drivers by turning a long, horizontal shaft with cogged gearing.

**76. Surveying Down Shafts.** In the case of very long tunnels it sometimes seems advisable to sink shafts at one or more points on the line of the tunnel, and when they have been sunk to the required depth, proceed to dig out the tunnel in each direction. For such work it becomes necessary to determine, at the bottom of the shaft, elevation, distance and alignment. If the shaft is vertical, as is usually but not always the case, the elevations are most readily carried down the shaft by means of a steel tape by methods which are obvious. Distance, which means in this case the longitudinal position in the alignment of the road of any given point, is readily transferred from the surface to the level of the tunnel by a very obvious application of the results of the next process to be described. Transferring the alignment with accuracy requires the utmost care and ingenuity. In principle it is very simple. Two heavy plumb bobs are hung on steel wires which are long enough to reach from the surface to the tunnel. At the surface they are placed on a line. Theoretically they should be on a line at the level of the tunnel. If a transit is so placed in the tunnel that its line of collimation passes simultaneously through both wires, it is in the line of the tunnel. Such is the simple outline; some of the difficulties are as follows:

Although the wires are set as far apart as possible along the line of the tunnel, the distance is absolutely limited by the size of the shaft. Any minute error in the location of these lines (say eight feet apart) will be greatly magnified when the headings are run out 6,000 or 7,000 feet in each direction from the base of the shaft, as was done in the case of the Hoosac tunnel. The currents of air up a tunnel shaft have considerable effect in swaying the wire from a true vertical. In the case of the Tamarack shaft, 4,250 feet deep, the wires were 0.11 foot farther apart at the bottom than at the top. The discrepancy *in that direction* had no effect on the alignment, but if the wires had an error whose combined effect in that direction was 0.11 foot, the lateral error while unknown was perhaps as much or more. The uncertainty was therefore in that case very great. Incasing such wires for the whole distance in a box reduces the effect of air currents. The plumb bobs are swung in pails of water or oil at the bottom and their locations noted as carefully as possible, taking the mean posi-

tion of the vibrations which cannot be altogether overcome. Marks are then set at the bottom of the shaft (but in the roof of the tunnel) from which plumb lines can be hung. A transit can then be set by trial so that its line of collimation simultaneously passes through both wires.

### TUNNEL DESIGN.

**77. Cross-Sections.** The variety in the cross-sections which have been adopted is due to the fact that there are no absolute requirements which determine the design except in a general way. If the tunnel passes through such very soft soil that there is excessive pressure the form should be circular or nearly so. While the size of the rolling stock is in one sense a limitation, yet the clearance should be considerable, partly for the reason of allowing something for a possible settlement of the lining. A majority of the sections used have a semi-circle or semi-ellipse surmounting a rectangle or trapezoid. Even when the ground is so soft that lining is required not only at the top but also at the sides and bottom, the same general shape will be used except that the straight lines will be replaced by arcs of circles concave to the center of the tunnel. Illustrations of cross-sections will be shown under a subsequent section.

A tunnel almost invariably strikes one or more veins of water which immediately begin to discharge into the tunnel, which thereafter becomes the drainage outlet for such water. This necessitates an adequate provision for drainage. In a double track tunnel the drain will usually be placed between the two tracks, but with single-track tunnels they must necessarily be placed on each side. Fig. 48 will illustrate this feature.

**78. Grade.** Many tunnels are situated at the summit of two grades, which are very probably the ruling grade of the road. In such a case it is possible to make the ends of the tunnel at practically the same level and have no grade in the tunnel except a slight grade for drainage. There should be no grade summit in the tunnel. Grade for drainage should never be omitted—about 0.2 per cent grade is required. But tunnels are frequently necessary as parts of a grade which is very possibly the ruling grade of the line. In such cases the grade should be very materially re-

duced while running through the tunnel. The atmospheric resistance in a tunnel is greater, the rails are apt to be wet and slippery and the tractive power therefore less, while the consumption of the limited supply of oxygen by the locomotive and the poisonous fumes cast off, especially when the engine is working hard, is a source of actual danger to the engine crew and even to the passengers. Therefore a generous reduction of grade should be made, although the precise amount of compensation required is hardly computable.

**79. Lining.** The lining required varies from no lining, such as may be permitted when the rock is so firm that it will be abso-

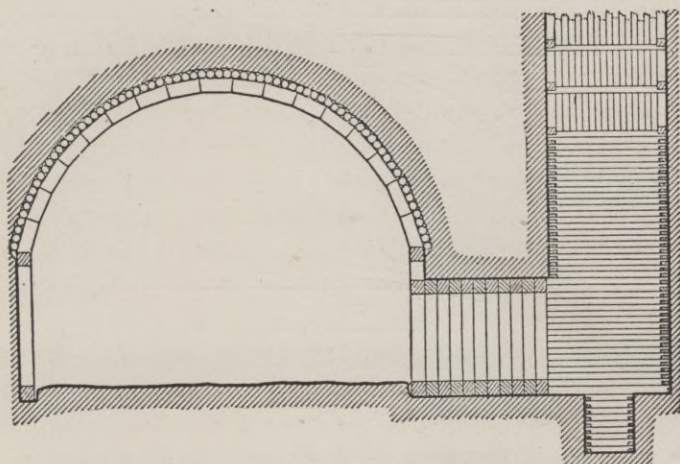

Fig. 47. Connection with Shaft, Church Hill Tunnel.

lutely self sustaining and will not disintegrate upon exposure to the weather, and a lining of the very heaviest and strongest cut-stone masonry which should be used when the ground is subject to extensive settling. This condition is far worse than any mere fluid pressure. Many American tunnels have been constructed with a permanent lining of timber, such as is illustrated in Fig. 47. In other cases the cross-section of a tunnel has purposely been made somewhat larger than necessary, so that when the timber lining required renewal a masonry lining could be built inside of the timber lining without encroaching on the required clear cross-section and without requiring any disturbance of the timber

lining. In this way the heavy expense of the masonry lining could be deferred until a time when the road would probably be better able to pay for it. True economy requires the best of cement masonry. When, on account of an unintentional fall of rock outside of the nominal excavation lines a space would be left between the lining and the line of the excavation, such space should be filled with broken stone well packed in or even with concrete or solid masonry.

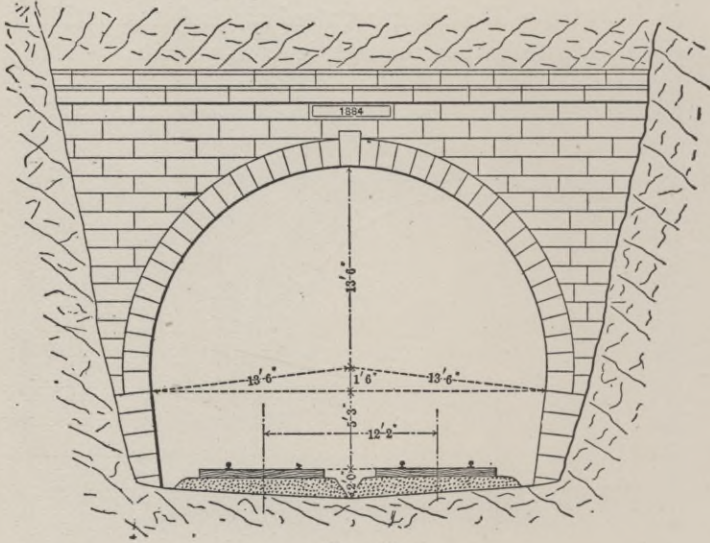

Fig. 48.

**80. Portals.** Although no calculations can be made to determine the forces acting on a portal, it is readily seen that they are sometimes very great, as they must often prevent a tendency of the face of the mountain to slide down over the tunnel outlet. In Fig. 48 is shown a typical portal. These are sometimes made very elaborate architecturally, but the leading feature of the design must be its massiveness. It must act as a retaining wall against the direct action of the slope. If there is also a considerable stretch of open cut at the entrance to the tunnel, then the design is really simplified by walls on the sides of the cut which will act as buttress walls to the portal. Some of the most difficult construction of a tunnel may occur at the portals. It is here that the thickness



of the natural "roof" of the tunnel runs out to practically zero. Considerable thickness is required before it will become self-sustaining enough to give opportunity to place the timbering. The surface soil may also be so loose that the excavation below starts a landslide. Therefore a very heavy timber frame must be constructed outside of the line of the proposed portal and must be very heavily braced to withstand a probable tendency to a landslide. In one case a shaft was sunk a short distance from the portal; tunnel excavation and permanent masonry lining was at once commenced, running back toward the portal. As the surface was approached the thin roof was so thoroughly supported that no serious difficulty was encountered from a landslide.

### TUNNEL CONSTRUCTION.

**81. General Principles.** A large majority of tunnels require a lining because the material through which they are excavated cannot be depended on to be self-sustaining. Except in sub-aqueous

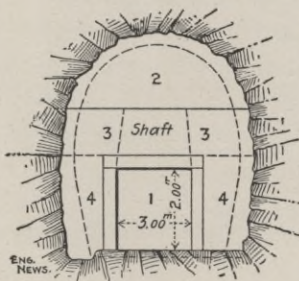

Cross Section.

Fig. 49.

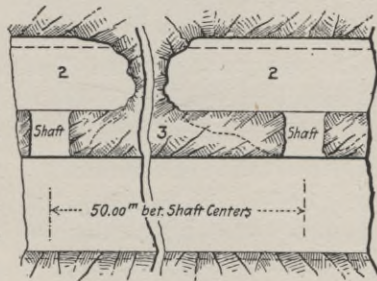

Longitudinal Section.

Fig. 50.

work, all material is self-sustaining over a small area and for a short time, a time long enough so that after a small area has been exposed a support even though temporary may be placed which will prevent a fall at that place. Since there are all gradations in material from the hardest of rock to the softest of quicksand, there are likewise gradations in the methods to be adopted, in the promptness with which timbering must be placed to support exposed areas and also in the extent of area which may be safely exposed before timbering is placed. All methods agree in excavating one or more headings in advance of the full sectional excavation.

These headings are sometimes made at the top, sometimes at the bottom and sometimes at the two lower corners. One good effect of such headings is to drain the soil in advance of the main excavation and thus facilitate the subsequent work. These headings are then enlarged until at last the full sectional area, including that required for the lining, is obtained. The construction of the lining follows closely, so that in a stretch of perhaps less than 80 feet may be seen all stages of the work, from the initial heading to the finished tunnel completely lined.

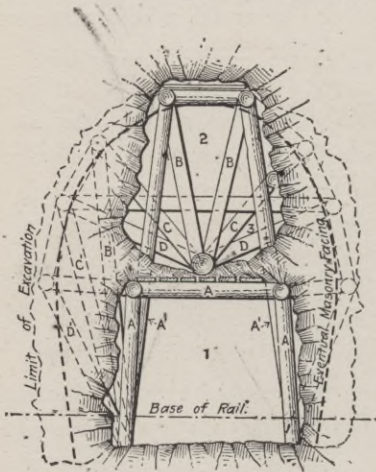

Fig. 51.

are used in this work. Some illustrations are shown to give the student such a grasp of the general principles involved that a generous application of common sense may enable him to accomplish some of the plainer and simpler problems. The timbering must be so designed and placed that there will be little or no tendency for the pieces to slip on each other and that any added pressure will only bind the framing still tighter together. The timbering should never fail except by absolute crushing, and its cross-section should be made such that it may withstand any probable pressure. An inspection of the illustrations will illustrate this.

82. **Methods.** The limitations of this paper will not permit a complete discussion and description of the various methods which

are used in this work. Some illustrations are shown to give the

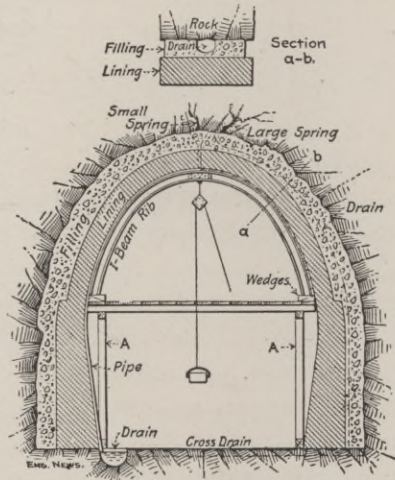

Fig. 52.

An inspection of the illustrations will illustrate this.

Much of the difficulty of tunnel work arises from the limited space in which the work must be done. A well-devised system of removing excavated material as rapidly as it is loosened and of handling the materials for the lining and placing them in position is therefore an absolute necessity. The use of small cars on rails is usually advisable. With a tunnel of any considerable length, artificial ventilation during construction is necessary, especially if blasting is required. As before mentioned, compressed air may be used to operate the drills for blasting and this may supply the need. But where no blasting is required, and sometimes even when compressed air is used, ventilation by fans is necessary. The fans and engines for operating them are of course placed outside the tunnel and the fresh air is discharged from a pipe where desired.

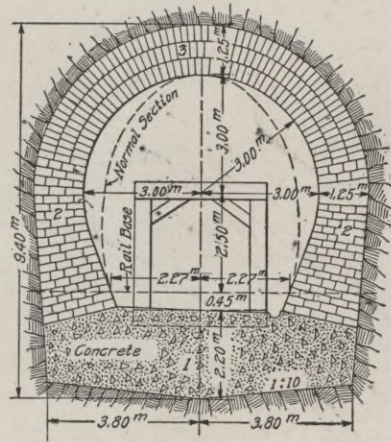

Fig. 53.

### TRESTLES.

A trestle consists of two essential parts, the sub-structure framework and the floor system. Since the floor system is essentially independent of the sub-structure, it will be separately described. There are two systems of building the sub-structure, by piling and by timber frames.

**83. Pile Trestles.** These are limited in height to the length of a single pile which may safely be used. The length of pile required must include the necessary depth to which they must be driven. On this account 30 feet above the ground is about the limit of height of a pile trestle. With exceptionally long piles higher pile trestles might be built, but framed bents would be preferable. Usually four piles are considered sufficient for single track, although more are sometimes used. The inner piles are always made vertical but the outer piles are sometimes battered so

as to give the trestle a greater resistance against a lateral thrust. For a high trestle (greater than 10 feet) this thrust is best taken up by sway bracing. The piles are surmounted by a cap which is generally  $10 \times 12$  in., or perhaps  $12 \times 12$  in. A still better form of cap is the "split cap," which consists of two pieces bolted together as shown in the detail of Fig. 56. Other methods of joining the cap to the piles are illustrated herewith. The construction using drift bolts is perhaps the cheapest and most quickly erected, but it has the disadvantage that repairs are difficult, and if the trestle is merely temporary it is almost impossible to remove it without ruining the timber for future use. The mortise and tenon joint is perhaps the most common for good practice. The piles should be not less than 14 in. in diameter at the butt and 7 in. at the top, exclusive of bark, which should be removed before driving. The soft durable woods such as cedar, cypress, pine and redwood are best for piles that are not driven in a stream where they may be subject to the blows of floating ice. The oaks are stronger but are less durable in the ground. The caps are preferably made of hard wood such as oak or yellow pine. They should be about 14 ft. long for single track. The sway braces are generally  $3 \times 12$  in. and are usually spiked with  $\frac{3}{8}$ -in. spikes 8 in. long.

**84. Pile Driving.** Piles are usually driven by means of a hammer weighing 2,000 to 3,000 pounds, which is raised between guides to a height of perhaps 25 feet and allowed to drop onto the head of the pile which is suitably set between the guides. A very cheap way is to raise the hammer by horse power, and then loosen a clutch which allows the hammer to fall freely. A still better way is to use a portable engine which winds the hoisting rope around a drum. Sometimes the falling hammer is required to draw the rope and unwind the drum as it falls. On the one hand, this obviates the use of a clutch and even permits more rapid blows, but on the other hand, the force of each blow is very materially weakened and the method may be used by a dishonest contractor to falsely indicate a high resisting power of the pile. Excessive driving has been known to fracture a pile underground and render it almost useless. The action of the hammer splinters the top of the pile, causing it to "broom." This action very greatly reduces the effectiveness of the driving. This is largely prevented by chamfering

off the top of the pile and driving on a wrought-iron ring, which has a section of about  $\frac{1}{2} \times 2$  in. and of a suitable diameter. The frequent removal of all crushed wood from the head of the pile by means of an adze is amply justifiable in spite of the delay caused. Piles should be driven until their resistance as indicated by the penetration for a single blow is as great as is required. The most commonly used formula is that known as the "Engineering News" formula, which when used for ordinary hammer driving is as follows:

$$R = \frac{2wh}{s+1} \quad (52)$$

In this formula  $R$  is the *safe* load on the pile,  $w$  is the weight of the hammer, both in pounds,  $h$  is the height of the fall in *feet*, and

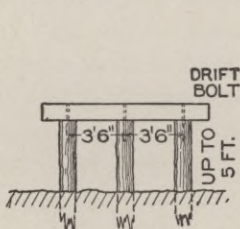

Fig. 54.

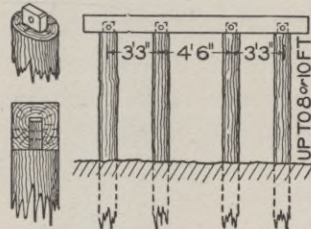

Fig. 55.

$s$  is the penetration in inches of the pile during the last blow. Sometimes the average penetration during the last five blows will give a more reliable value.

*Example 1.* A pile was driven with a 2,500-lb. hammer until the total penetration during the last five blows was 13 inches. During those blows the hammer dropped 23 feet. How much is the safe load?

$$\frac{2wh}{s+1} = \frac{2 \times 2,500 \times 23}{\left(\frac{1}{5} \times 13\right) + 1} = \frac{115,000}{3.6} = 31,944 \text{ pounds.}$$

*Example 2.* It is required to drive piles with the above hammer until the indicated resistance is 25,000 lb. What should be the average penetration during the last five blows, the fall being then 22 feet?

$$25,000 = \frac{2wh}{s+1} = \frac{2 \times 2,500 \times 22}{s+1} = \frac{110,000}{s+1}$$

$$s = \frac{110,000}{25,000} - 1 = 3.4 \text{ inches.}$$

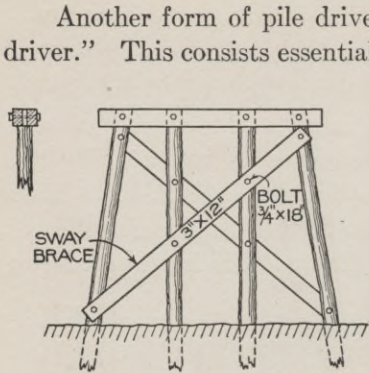

Fig. 56.

Another form of pile driver is that known as the "steam pile driver." This consists essentially of a hammer which is directly attached to a piston in a steam cylinder. The hammer, weighing about 5,500 pounds, is raised the height of the cylinder, which is about 40 inches, and then falls freely. Although the fall is so much less the blows are very rapid—about 75 to 80 per minute. The practical effect of this is that the soil does not have time to settle between the blows and the penetration is more easily

accomplished, while the ultimate resistance is as great as before. On this account the constant "1" in the denominator in equation 52 is changed to 0.1 and the formula then becomes

$$R = \frac{2wh}{s+0.1} \tag{53}$$

FRAMED TRESTLES.

85. **General Form.** Although there are multitudinous variations in the details of construction, a very large proportion of framed trestles are constructed substantially in accordance with the typical design shown in Fig. 57. The outer posts are generally battered about 1:6; the cap and sill are mortised to the posts, although split sills and caps can be used advantageously. The sway bracing should be bolted on. Although the mortise and tenon joint are most commonly used, there are many other designs. The "plaster joint"

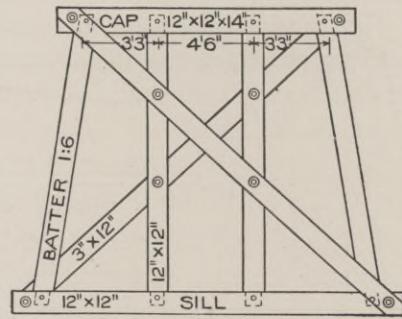

Fig. 57.

is one of the most common. This consists of two pieces of 3-in. plank which are placed on each side of the joint as in Fig. 58, and are bolted through and through. This form has the merits of

cheapness and facility for taking out and renewing any decayed or injured piece. Iron plates are sometimes used in a similar manner. Dowels and drift bolts are also used, but as mentioned before have many objections.

**86. Multiple Story Construction.** A single-story framed trestle should not be made over 25 or 30 feet high. Additional height is obtained by dividing the height into two or more stories. Then since all the upper stories must be of uniform height the odd amount must go to the lower story, as is illustrated in Figs. 59 and 60. Some plans have

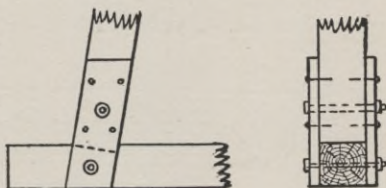

Fig. 58.

these stories absolutely independent of each other. This simplifies the construction and makes repairs easy, but the trestle will be lacking in stiffness. These illustrations should be studied with

special reference to the design of the lateral bracing of the individual bents and also the longitudinal bracing of the trestle as a whole. Note that the lateral bracing always runs to some point where two or more pieces intersect, and when possible it is so designed that even the intermediate points are a common point for several pieces. A thorough bolting at these points greatly stiffens the structure. The span between the bents varies from 10 feet to 18 feet. For high trestles economy requires that the number of bents shall be reduced as much as possible, which means that the spans should be increased. But this increases the requirements for the floor system, and also the load to be carried by each bent. 18 feet is about the safe limit for railroad rolling stock on untrussed wooden floor beams.

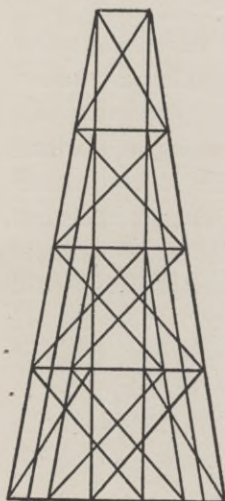

Fig. 59.

**87. Foundations.** Trestles are frequently to be classed as "temporary" structures. Such will justify the use of a foundation of a more temporary character than could be tolerated for per-

manent work. When time is important and the ground soft, piles are sometimes driven and sawed off a little above the ground. They are so placed that a pile comes as nearly as possible under each post of the trestle. Of course, such foundations must be considered as very temporary in character, as they will speedily decay to such an extent as to render them unsafe. Locust or chestnut are preferable for this purpose.

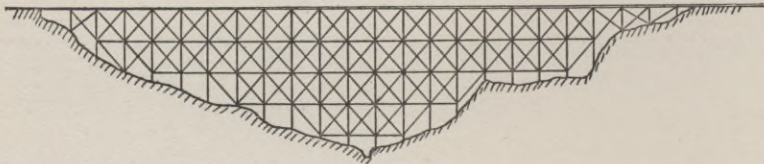

Fig. 60.

Another form which is even easier to construct, but which is, if possible, still more subject to decay, is the "mud-sill" foundation. The sill of the trestle is set on a number of timbers placed transverse to the sill, the timbers being about  $12 \times 12$  in.  $\times$  6 ft. If the ground is very soft even these timbers may be set on two or more long timbers, laid parallel to the sill, as shown by the dotted lines in Fig. 62.

When the trestle is intended as a permanent structure, and especially when it is intended to ultimately replace it with a steel viaduct, a stone foundation may be used. If built of rough rubble the wall should be about 4 feet thick. If the masonry was of a better class the wall need not be so thick, but the cost would be about the same. Usually a single continuous wall would

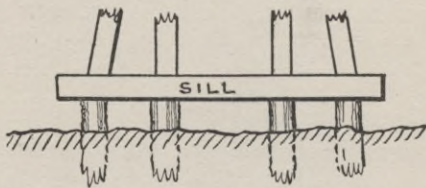

Fig. 61.

be built, but if the trestle is very high the usual batter adopted for the side posts will make the sill very long. With some designs of trestles, depending, however, on the plan of the posts, it is permissible to save some masonry by omitting portions of the wall between the center and the ends.



88. **Abutments.** At each end of a trestle the natural surface usually approaches the grade line by a slope. If stone foundations were built for the bents, then stone abutments would be built which would act as a retaining wall for the last few feet of rise and which would support the last stringers. When piles are used an abutment such as indicated in Fig. 63 is used. When no piling is used, an abutment may be made in the form of crib work. Sometimes one end of the last line of stringers is merely buried in the earth or is supported on a "mud sill." Of course, all of these latter methods should be considered as temporary. The danger in them lies in the chance of these places being neglected and the decay unnoticed until the decayed timber suddenly gives way and a costly accident is the result.

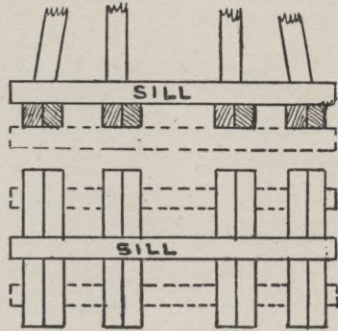

Fig. 62.

#### TRESTLE FLOOR SYSTEMS.

89. **Stringers.** The design of stringers depends somewhat on the cost and practicality of obtaining timbers of the length and thickness that theory would call for as the most economical size. Sound timber of the required length, and more than 16 or 17 inches in thickness, is scarce and correspondingly costly. The required transverse strength for stringers is, therefore, obtained by taking as large pieces as may be readily obtained, setting them on edge or with the largest cross-sectional dimension

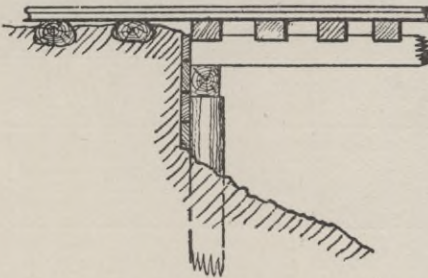

Fig. 63.

vertical, and then bolting two or more of them together side by side. Two timbers, each 8×16 in., bolted together side by side

with the 16 in. dimension vertical, are practically as strong as a 16×16 in. timber, and are very much easier to obtain in a sound condition. These stringers should preferably extend over two spans, the lines "breaking joints." This requires pieces from 20 to 32 ft. in length. The pieces of each line should be separated by "separators," which are sometimes cast-iron spools, 1 or 2 in. long, which are strung on the bolts, or are sometimes made of pieces of plank about 6 feet long. Bolts are run through the stringers and separators. The plank separators thus serve to tie the consecutive stringers together. The chief object of the separators is to permit air to circulate freely around the timbers. Placing the rough sawed timbers side by side would allow water to soak in and be retained, so that decay would be very rapid. The design of stringers is susceptible of exact calculation for the transverse strength required, but as this is a direct application of the subject of "Strength of Materials," the method of design will not be elaborated here, except to call attention to the fact that the stringers must be designed to withstand not only transverse strains, but also shearing and crushing across the grain where the stringer rests on the cap. A very high and narrow stringer might have sufficient transverse strength, but might be so narrow that it would fail by shearing along the neutral axis. The same stringer might also have such a small area where it rests on the cap that the safe limit of crushing across the grain might be exceeded. The safe values to be used with various kinds of wood for these various stresses may be found in many handbooks. The following dimensions have the approval of very extensive practice:

Clear Span.	Number of pieces under each rail.	Width.	Depth.
10 feet.	2	8 inches.	16 inches.
12 "	2	10 "	16 "
14 "	3	10 "	16 "

**90. Corbels.** A corbel in a trestle is the name applied to a timber placed on the cap of the trestle bent and on which the stringers rest, Fig. 64. The argument in favor of their use seems to be that they greatly increase the area of pressure on the seat of the stringer. They can also be utilized to bind together two abutting

stringers. But although the crushing of the end of the stringer may be prevented, the area of contact between the corbel and the cap must be considered, to determine whether crushing might

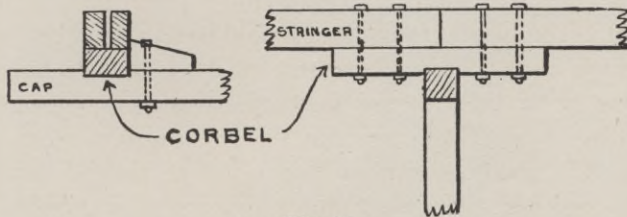

Fig. 64.

occur there. There is great diversity of opinion regarding their use. Many standard designs do not use them.

91. **Guard Rails.** These are timbers varying in size from  $5 \times 8$  in. to  $8 \times 8$  in. which are placed near the ends of the ties. They are usually notched about 1 inch at each tie so that they really form tie spacers and thus prevent the ties from becoming

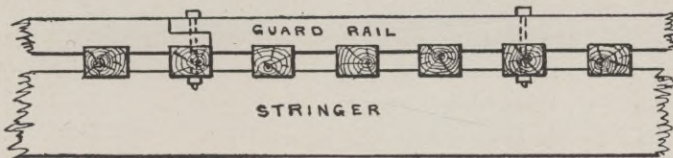

Fig. 65.

displaced if a car becomes derailed on the trestle. They should be bolted to the ties at every third or fourth tie. There are various methods of jointing the ends of abutting pieces. The method shown in Fig. 65, is perhaps as good as any.

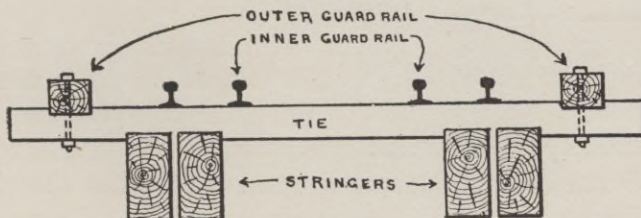

Fig. 66.

The name guard rail is also applied to the inner guards which are placed about 10 in. inside of each rail, Fig. 66. These are usually

the ordinary T-rails used for traction. These rails are relied on to keep the cars on the trestle if they should become derailed. If a car should become so displaced that the wheel reached the outer wooden guard rail, it would probably catch on it, slew around and jump over. Therefore the sole function of the outer wooden guard rail is to keep the ties spaced and in place.

**92. Trestle Ties.** Trestle ties are always made of sawed timber. They are longer than ordinary ties—usually 9 to 12 feet. The depth is frequently much greater, with the apparent idea that they may act as a flooring that will support the rolling stock if it should become derailed. For a similar reason the spacing is made very much closer—generally equal to or less than the width of the ties. Sometimes even the ties are notched on the underside where they rest on the stringers. Some plans have a stringer run

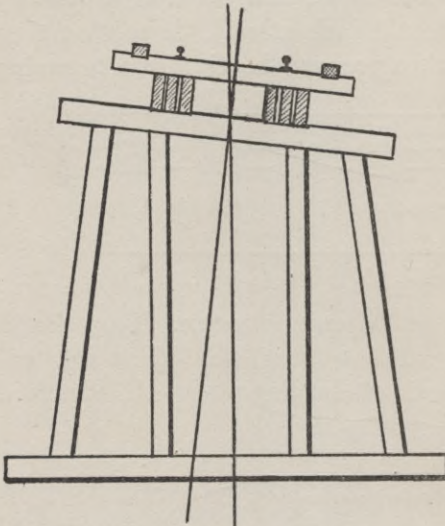

Fig. 67.

under each guard rail. Then bolts will be run through the stringer, tie and guard rail at every third or fourth tie. If the ties have been notched down on the stringers and the guard rail is notched down on the ties, then these bolts will tie the whole system immovably together.

**93. Super-Elevation of the Outer Rail on Curves.**

Locating a curve where a trestle is also necessary, is in general very objectionable, but it is sometimes unavoidable. The objection

lies not only in the fact that a very considerable force is required to guide the train in its circular path, but the force is variable, depending on the variable speed, and there are apt to be oscillations of unknown force which will still further rack the trestle. Nevertheless these forces must be provided for as closely as possible. If all trains moved along the trestle at precisely the same speed,

the problem would be comparatively simple. The whole floor system could be designed to resist the thrust due to the forces developed at that speed. But since the speed may vary down to zero, and the train start from rest while on the trestle, which of itself will introduce new strains, the construction which is best for the highest speed is not the best when the train is standing on the trestle, or when it is starting, and *vice versa*. A few of the many designs which have been used will be illustrated, together with a brief comment on the advantages and disadvantages of each design. The required super-elevation of the outer rail and the method of computing

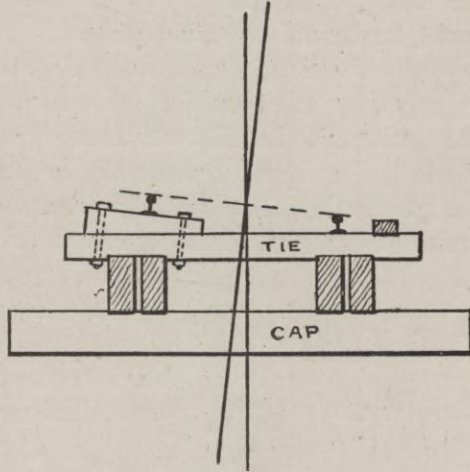

Fig. 68.

it will be discussed in the chapter on track work and track laying.

(a) *Inclining floor system and cap; sill horizontal; outer posts longer, Fig. 67.* The construction of the trestle bents is more complicated,

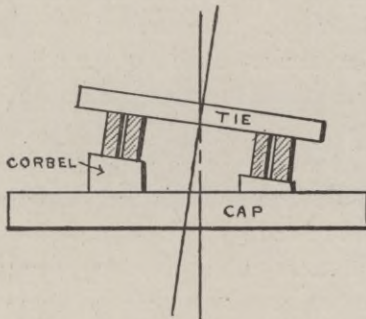

Fig. 69.

but that of the floor system is simplified. Since the stringers do not stand vertically there is a tendency for them to twist when the train is stationary.

(b) *Placing wedges under the ties at each tie.* Two or more wedges are required for each tie. Each wedge is bolted by two bolts. The number of pieces is very great, but there is the advantage

that the ties are not notched or weakened in any way. If for any reason a different super-elevation is desired the wedges are all that need be changed.

(c) *Placing a wedge under the outer rail at each tie, Fig. 68.* This is similar to the last method, but requires fewer pieces. If the super-elevation is slight, either very long spikes must be used or lag screws may be used which will run through the wedges into the ties. For a greater super-elevation the wedge must be fastened, as shown in the illustration.

(d) *Corbels of varying height, Fig. 69.* The whole floor system is tipped as in *a*, but the trestle bent is as usual, with cap and sill horizontal. In all such cases, where the axis of the post is vertical, the lateral bracing of the bent should be made extra heavy. It should be especially noted whether the center of pressure under extreme conditions reaches the sill too near the outer end of the sill.

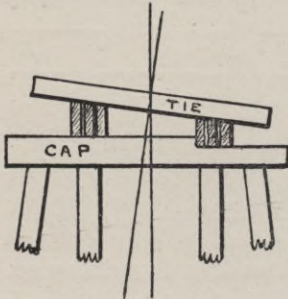

Fig. 70.

(e) *Tipping the whole bent on its foundation.* The advantages and disadvantages of the method under some conditions are obvious.

(f) *Notching the cap, Fig. 70.* The method is mentioned on account of its frequent use, but the disadvantages are very great. The cap is weakened by the notching. Either the stringer or the tie must be notched at each tie. Usually the

tie would be hopelessly weakened if it were notched sufficiently, and, therefore, the stringers must be notched. The method is costly in construction and objectionable when made. The above methods are types of a great variety of plans of construction which have been suggested and tried.

**94. Protection Against Fire.** One of the strongest objections against the use of trestles is the danger from fire. Sparks from the locomotive or wayside fires kindled by tramps and others may destroy them, or, what is still more dangerous, may slowly eat into the timbers until they are weakened beyond the danger line, and yet, because the effect of the fire is not apparent to a careless inspection, it may result in an appalling accident. The danger from falling coals from the locomotive firebox is largely obviated by constructing a solid floor or trough on the stringers, the trough being filled with ballast and the ties set in the ballast



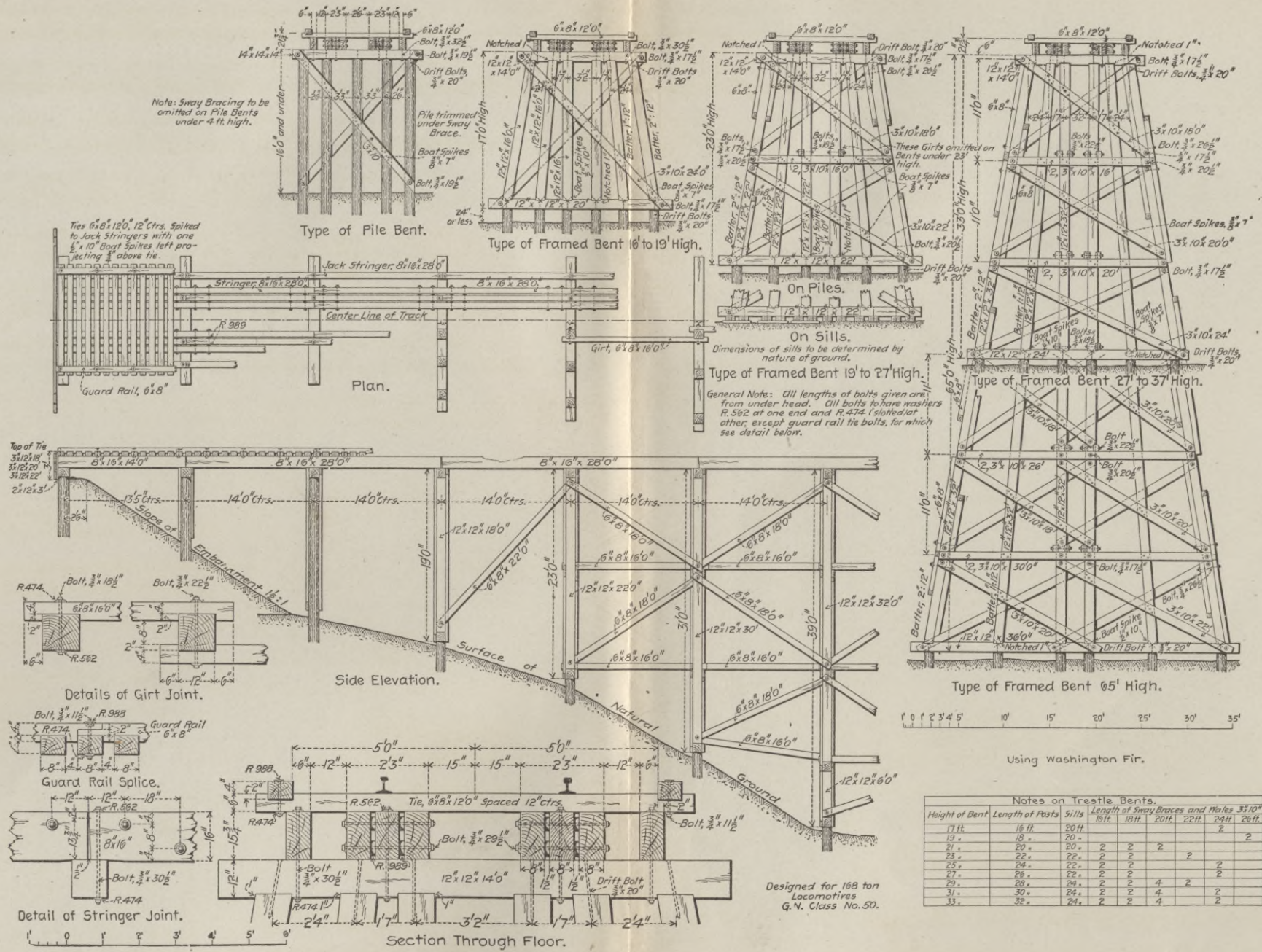

Fig 71. Standard Framed Trestle as used on the Great Northern Railroad





as usual. Another method is to cover the stringers and caps with sheet metal. A very long trestle generally deserves the protection of a special watchman or track walker. Means for fighting a fire when discovered are provided by reservoirs of water, made perhaps from halves of oil barrels, which are placed on the trestle at intervals of 300 feet. Three or four ties are made about 4 feet longer than the usual length. These form the floor of a platform, which, when provided with a railing, forms not only a place for the barrel, but also a refuge bay for the track walker, who may be on the trestle when a train is passing.

**95. Choice of Timber.** When a railroad is being run through a virgin country where timber is plentiful and there is frequent occasion for trestles, it pays to take a portable sawmill to the spot and saw the timber as required. Under such conditions any one of the various kinds of timber which are ever used for building purposes will answer. If necessary, the cross-sections can be increased to correspond with the reduced strength of a weaker wood. But when the wood must be transported a considerable distance and it is practicable to choose among various kinds of wood, the selection should be made according to favorable qualities. Ties and guard rails should, if possible, be of oak. Stringers should be made of oak or pine. Since one of the chief uses of corbels is to relieve a dangerous pressure across the grain they should be made of the hardest wood obtainable, such as oak, hickory or ash. The bents of a framed trestle may be made of almost anything, but oak, pine or fir are preferable when obtainable. If the sills are liable to become buried somewhat in the ground so that rain will not readily be shed, then some wood like cedar, which is very long-lived under ground, might be preferable, but the strength as posts will be somewhat less than that of oak. The chemical treatment of timber for trestles is seldom used, except for trestles which are partly immersed in water where the *teredo navalis* is found. Trestles are usually considered to be so cheap and temporary that conditions which would justify the additional expense of chemical treatment would also justify the immediate construction of a permanent structure of steel or stone.

On the folding plate, Fig. 71, is shown the standard plans for a framed trestle as adopted by the Great Northern Railroad.

Many of the details shown will verify those already mentioned, while in other cases the variations in detail represent practice equally good. The plate is well worthy of a long and close study.

### CULVERTS.

**96. Pipe Culverts.** The scarcity of stone suitable for making a "box" or "arch" culvert has led to the adoption for many localities of pipe culverts, the pipes being made of tile or iron, Fig. 72. Pipes have several very great advantages. Their form is hydraulically better than any rectangular form and the surface is

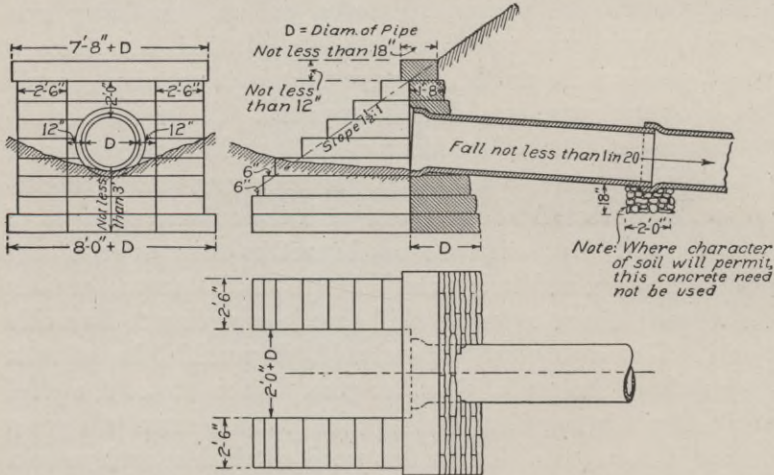

Fig. 72. Pipe Culvert.

usually very much better than an ordinary masonry culvert. Therefore they will discharge a far greater volume of water than a box culvert of equal area. They are very easily placed without skilled labor. Sometimes they are set inside of a wooden box culvert temporarily placed during the construction of the road. When one pipe of the size which it is desired to use has insufficient area two or more pipes may be used side by side. This feature is of special value when the head room between the bed of the stream and the grade line is limited. Iron pipe usually has such inherent strength that there is little need for special care in securing a foundation for the pipe. A little block of concrete at each joint is sufficient for ordinary cases, but tile pipe requires a secure foundation.

The danger to the pipe does not lie so much in the mere static pressure of the earthwork embankment above it as in the effect of settlement of a "green" embankment. If the pipe is laid on the natural soil, which might be tolerated if it is very firm, a bed should be carefully scooped out so as to fit the pipe as closely as possible. A better plan is to place a thick layer of broken stone or brickbats and ram them to the proper form as a bed for the pipe. A still better plan is to place a layer of concrete under the whole length of the pipe. The required slope of the pipe depends somewhat on the accuracy of the laying and on the permanency of the work. A slope of 1 per cent is ample, provided the grade be made and maintained uniform, but the effect of settlement may be to change such a grade to a negative grade, which would prevent the water from being carried off. Some standard plans there-

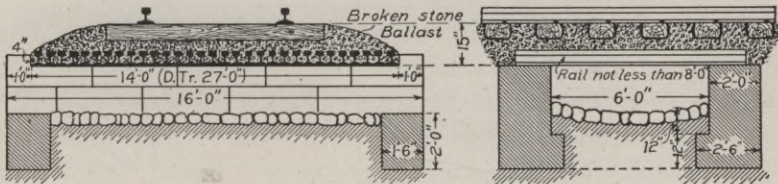

Fig. 73.

Old-Rail Culverts.

Fig. 74.

fore require a grade as steep as 1 in 20. At each end of the pipe there should be a substantial head wall of masonry. Some standard plans make this wall very large and heavy with elaborate wing walls. These are justifiable on the grounds of preventing the water at the upper end from scouring around the ends of the head wall or of preventing the outflowing water from scouring away the bed of the stream and thus undermining the lower head wall.

An iron pipe can be used if necessary very close to the ties, but a tile pipe should have a cushion of at least three feet between the tile and the ties. The joints in the pipe should always be caulked. Clay puddle is much used for this purpose and when it is of good quality and the work well done, the results are satisfactory, but if clay puddle cannot be obtained it is better to use hydraulic cement. The cost of the cement is an insignificant item considering the value of the result.

**97. Old-Rail Culverts.** These have an especial value when the head room between the bed of the stream and the rails is small, and when it is also necessary to provide for a considerable flow of water. The old rails, even when worn out as rails, still have a considerable strength as girders and a continuous layer of them is amply strong enough to carry the roadbed and the traffic over a six-foot opening. The rails may be bound together by means of tie rods run through the webs of the rails, but they may also be confined by stones at each end of the seat course on each abutment, Figs. 73 and 74.

Another advantage of this form of opening, over the common plan of supporting the ties on stringers or steel girders, is that in this plan the ballasted roadbed is continuous. This is a great advantage both from the standpoint of smooth riding and of safety.

**98. Cattle Passes.** When an embankment crosses a farm, cutting it in two, it becomes necessary for the road to provide a passage way through the embankment for the use of cattle and farm wagons. The cost of such a structure is compensated by the relief of the company from damages due to the cattle crossing the road at grade. These openings are sometimes built as large stone arch culverts or as old-rail culverts, especially if there is liable to be a storm-water flow through them. Another method is to set two trestle bents at the requisite distance apart; 3-inch planks are set behind the bents to hold the earthwork embankment; the stringers are notched down so as to take up the thrust of the embankment. This method naturally applies to embankments which are from about 8 to 15 feet in height. The disadvantage incident to all wooden structures set in earth also applies here. There is also the disadvantage of a break in the continuity of the ballasted roadbed, as well as the danger due to an accident from fire destroying or weakening the structure. When the head room is limited, a first-class permanent construction can best be obtained by the "old-rail" method or something similar.





EXAMPLE OF MODERN RAILWAY CONSTRUCTION. TRACK LAYING MACHINE AT WORK

# RAILROAD ENGINEERING.

## PART II.

---

### MISCELLANEOUS STRUCTURES.

99. **Water Supply.** The railroads of the country spent in 1910 over \$13,000,000 in supplying water to their locomotives. Part of this expense is due to the fact that a bad quality of water is so injurious to a locomotive boiler (as well as rendering it difficult for the boiler to steam properly) that the added expense of procuring a suitable supply of naturally pure water or of purifying an impure supply is amply justified. A natural water supply is always more or less charged with calcium and magnesium carbonates and sulphates in addition to impurities of almost any nature which come in as the refuse from factories, etc. Some of these impurities are comparatively harmless, especially if the quantity is not large. But the evaporation of the water precipitates the calcium and magnesium, which form deposits on the surface of the boiler.

These deposits are injurious in two ways. In the first place the transfer of heat from the fire to the water is less free and there is thus a waste of energy, and in the next place the metal becomes overheated and perhaps "burned." The safety of the metal of a boiler depends on the free transfer of the intense heat of the fire to the comparatively low heat of the water or steam. The prevention of these deposits may be accomplished in one (or both) of two ways; the frequent cleaning of the boilers through the manholes and handholes provided for the purpose, and by the more or less perfect purification of the water before it enters the boiler.

The location of the water stations must be at such places and intervals as the service demands. There must always be a supply at the extremities of each division and usually at intervals of 15 to 20 miles between. Of course these intervals are varied according to the location of convenient sources of supply. The frequent



erection of municipal plants for water supply even in small places has led to the utilization of such plants, since a suitable supply for domestic use is usually satisfactory for boiler use, and since a reasonable charge to such a large consumer would generally be far less than the cost of maintaining a separate plant. In default of such supplies, a convenient intersecting stream, especially when combined with an existing but perhaps abandoned mill dam which will form a convenient storage reservoir, may be utilized. If the stream passes through a limestone region, the water may become so thoroughly impregnated with calcium compounds that a purifying plant will become a necessity and then there may arise the question of a choice between a conveniently located station with a necessary purifying plant and a less convenient location but a natural supply of purer water.

The chemical purification of water for railroad purposes has become a specialty and must be studied as such. Of course no attempt is made to produce chemically pure water as that would be unnecessarily costly. The reagents chiefly employed are quicklime and sodium carbonate. The lime precipitates the bicarbonate of lime and magnesia in the water. Sodium carbonate gives, by double decomposition in the presence of sulphate of lime, carbonate of lime, which precipitates, and soluble sulphate of soda, which is non-incrustant. The precipitates settle to the bottom of the tank and are drawn off while the purified water is drawn from the upper portion of the tank. Such purification may be accomplished for a few cents per thousand gallons. Still another method of preventing incrustation in the boiler is to introduce directly into the water tank a "non-incrustant" which, as its name implies, will so change the composition of the impurities that they will settle harmlessly and may be readily blown out.

*Pumping.* Except when water is obtained from a municipal water supply it must be pumped into a tank or reservoir which is usually placed with its bottom 12 to 15 feet above the rails. The pumping may be done with a wind mill, which is very cheap but unreliable, or by an ordinary steam pump operated by a boiler fed with coal, or by a gasoline engine. The last method is becoming very popular, as the pumps require but little attention and the cost of operating them has been found to be as low as one-third or even

one-fourth of the cost of steam pumping. And this is true in spite of the fact that a railroad can usually deliver slack coal or screenings at a pump house along the line of the road at a cost that may not exceed 30 cents per ton. The cost of pumping to a track tank will usually run at from 2 cents to 6 cents per 1,000 gallons.

*Tanks.* The construction of the piping from a tank and even of the tanks themselves has become a specialty by manufacturing firms who can make and sell them much cheaper than may be done by any "home-made" method, and, therefore, the details of manufacture need not be here discussed. The tank must be so placed that its nearest face is about 8 feet 6 inches from the track center. When one tank is to serve several tracks or when the supply is taken from a city waterworks, a "stand-pipe" is necessary. This consists essentially of an upright pipe which stands about 14 feet above the ground where it has a horizontal arm about 7 feet long. This elbow may be turned so that the arm is either parallel or perpendicular to the track. As shown in Fig. 75, the valve mechanism is buried underground and the roof of the pit is protected so that freezing shall be obviated.

*Track Tanks.* The demands for high speed require that long runs shall be made without a stop even for water. Very long runs can only be made by taking on water while in motion from a track tank. These have a length of 1,200 to 1,500 feet and must be laid on a stretch of perfectly level track. A large item in the

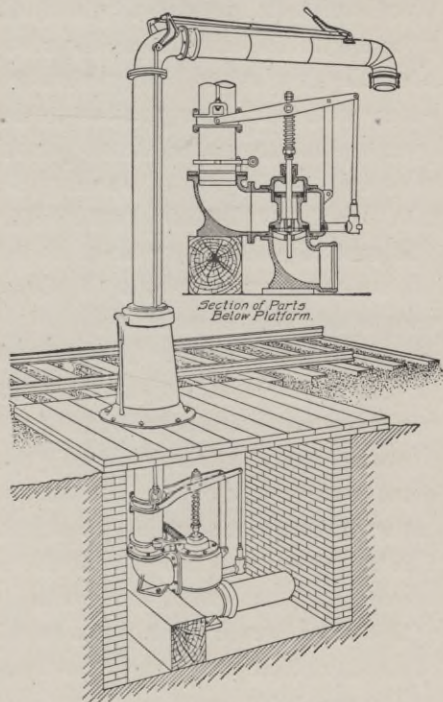

Fig. 75. Automatic Standpipe.

expense of installing such a plant is the cost of the re-grading which is usually necessary to make the track perfectly level. On the ties and midway between the rails is a tank about 19 inches wide, 6 inches deep and as long as desired. This trough will be made of  $\frac{3}{16}$ -inch steel plate, stiffened and reinforced with angle bars. Such tanks can only be used by engines which are provided with a scoop on the tender which is lowered at the proper time. The high speed causes the water to rush into the scoop with such velocity that it is easily carried to the top of the leader pipe and over into the tender tank. An inclined plane at each end of the trough automatically raises the scoop and when raised it is automatically caught and held so that there is no danger that the scoop shall catch in anything on the track. To prevent the water from freezing in the winter, steam jets should be blown into the water at every 40 to 50 feet of its length. The steam required for this may be many times as great as the steam required for pumping. The cost of such an installation will be upwards of \$10,000 and the annual expense about \$1,500. Of course these figures will vary with the circumstances.

**100. Turntables.** The turntable proper is an example in structural engineering which is now almost universally made of structural steel in shops which make such work their specialty. Therefore no discussion will be given of the table. But the table must be supported on a pivot which must have an adequate foundation which must be able to support a load of perhaps 200 tons. The table revolves in a pit which is say 75 feet in diameter and which must have a retaining wall about it. Immediately inside of this wall is a circular track on which rollers on the under side of the turntable may run if the load is eccentric. Since this load on the rail may be large it must have an adequate support.

If the turntable must be located on what is originally sloping ground, the masonry may need to be quite deep and heavy, since the foundation for the pivot should be especially firm. If the subsoil is not self-draining, it should be thoroughly drained by a thorough sub-drainage and the pit should be drained by a pipe leading to a suitable outfall. A turntable is usually located as an adjunct to a roundhouse, but in any case the location should be made so that the switching that must be done before and after

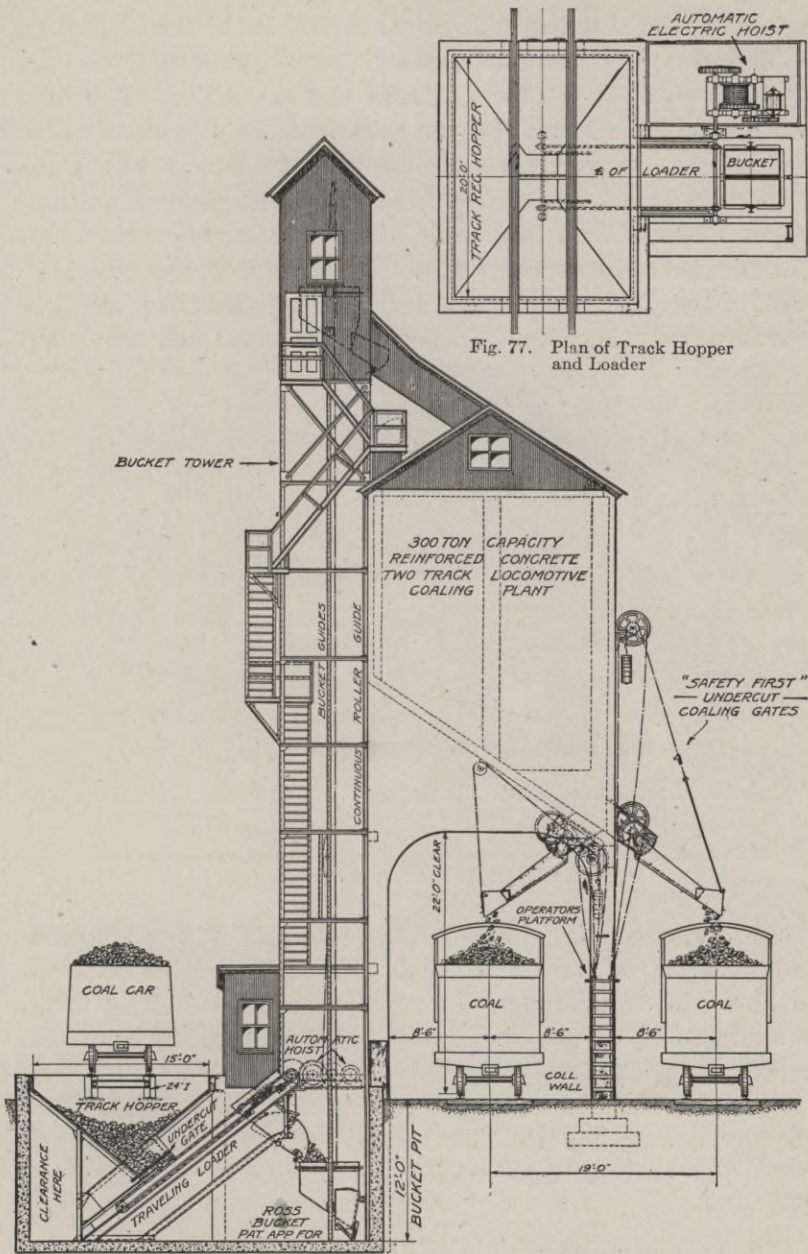

Fig. 77. Plan of Track Hopper and Loader

Fig. 76. 300-Ton Reinforced Concrete Locomotive Coaling Plant, Provided with "Duplex" Shallow Pit Loader.

Courtesy of Roberts and Schaefer Company, Chicago

using the table shall be made a minimum. The location of the turntable in the yard is an item in the subject of Yards and Terminals.

**101. Coaling Stations.** The cost of removing ashes from the ashpan of a locomotive to a suitable dumping ground and of supplying the tender with coal may amount to a very considerable item unless special facilities are devised for doing the work cheaply as well as rapidly. Such facilities are especially necessary when the number of locomotives to be taken care of is very great. As will be seen from the vertical section of a Roberts and Schaefer concrete coal loader, Fig. 76, the coal car is placed over the 12-foot

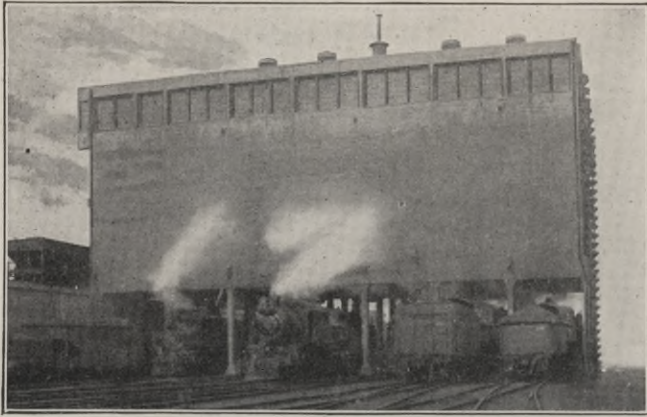

Fig. 78. Electrically Operated 2000-Ton Coaling Station  
Fourteen engines can be supplied simultaneously with coal, sand, and water.  
*Courtesy of Link-Belt Company, Chicago*

pit, a hopper receiving the coal from the car and a traveling loader conveying it to the bucket hoist. By means of the hoist the coal is carried to the top of the tower and automatically dumped into the storage bins. In Fig. 77 is shown the plan view of the bucket pit.

Another concrete coaling station built by the Link-Belt Company is shown in Fig. 78. This has a capacity of 2,000 tons of coal and is also provided with sand bins and facilities for taking care of the cinders.

**102. Engine Houses.** On very small roads, where the number of engines to be housed at any one place will never exceed five

or six, a rectangular engine house with two or three parallel tracks is the cheapest form of construction. But as the number of engines to be provided for increases, and as space grows more valuable, the "roundhouse" is preferable. Considering the space, tracks and switches required to run a large number of tracks into a rectangular house, the roundhouse will accommodate more engines in proportion to the space required. A turntable is a necessary feature of a roundhouse, but since a turntable would naturally be located at any point on a road where an engine house was required, the cost of the turntable should not be considered as an integral part of the cost of the roundhouse.

Engine houses are used for the minor repairs which continually form a part of the maintenance of any locomotive. Therefore a portion of the tracks should be provided with "pits" or spaces between the rails in which work may be done under the engine. The outer walls are preferably constructed of masonry, although wooden structures are not uncommon on cheaper roads. The roof framing should preferably be of wood, as iron trusses deteriorate very fast under the action of the gases of combustion from the engines. The effect of this is prevented as far as possible by "smoke jacks," which are chimneys suspended from the roof so that they are immediately above the engine stack when each engine is placed where designed. The lower part of this chimney is made adjustable so that it may come down closely over the stack. The smoke jacks are variously made of galvanized iron (very short lived), vitrified pipe (too brittle), cast iron (very heavy), expanded metal and concrete, and even plain wood painted with "fireproof" paint. The floors are best made of brick; cinders are cheap but objectionable, wood is tolerable but lacks durability, concrete is almost an extravagance. Considering that the larger roundhouses may contain locomotives worth several hundred thousand dollars, fire protection is an important feature. One means to this end is the use of rolling steel shutters instead of wooden doors. In Fig. 79 is shown some of the details of what may be considered a typical roundhouse. The figure will illustrate many of the points named above.

**103. Cattle Guards.** The prevalent opinion that a railroad company is responsible for the death or injury of any cattle which

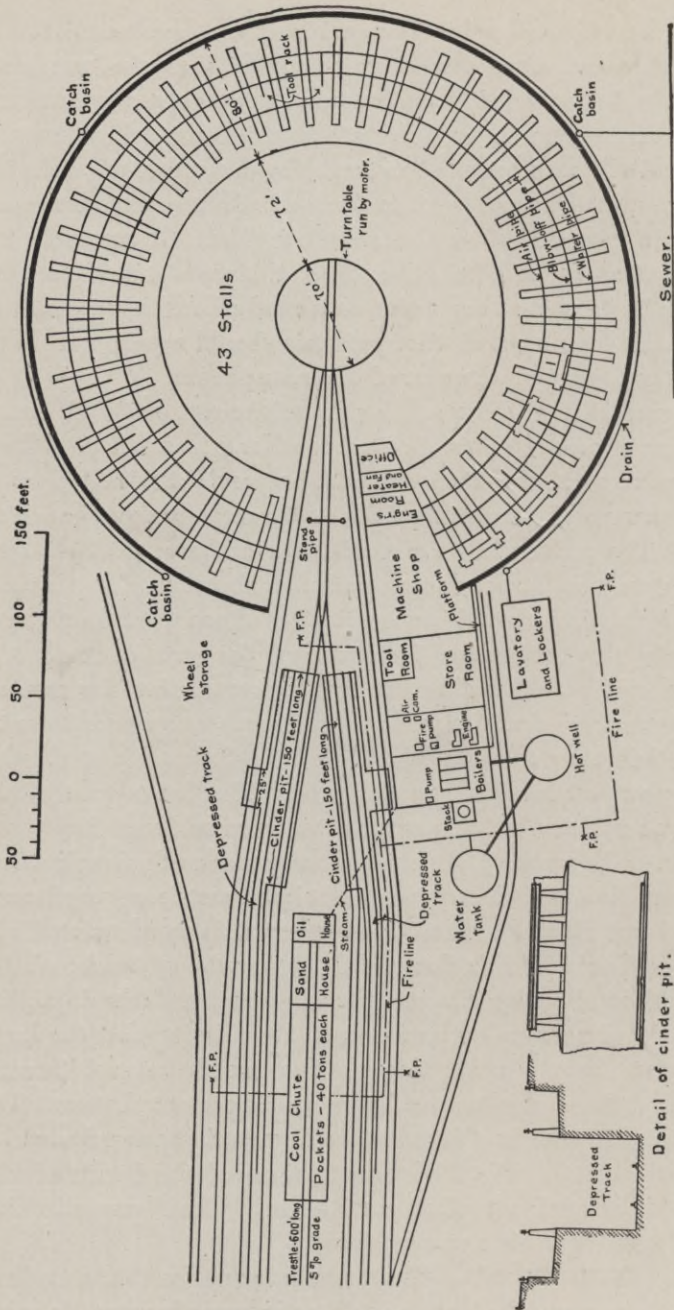

Fig. 79. Details of Typical Roundhouse.

may stray on its right-of-way requires especial precautions that cattle, straying along a highway, shall not turn into the railroad right-of-way. The fundamental idea is a structure which is not

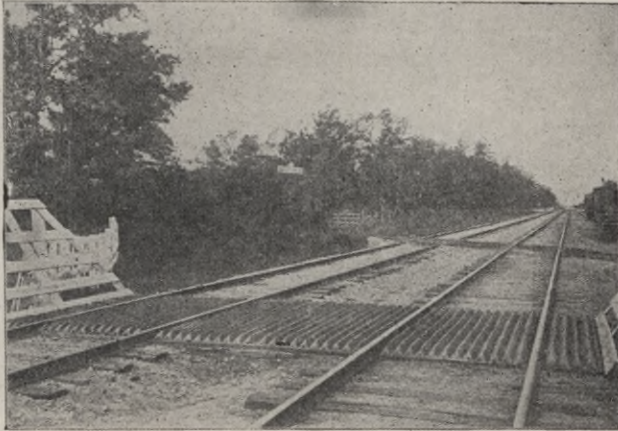

Fig. 80. Climax Cattle Guard.

an obstruction to trains but over which cattle will not pass. The old way was to use a pit about two feet deep and four feet wide

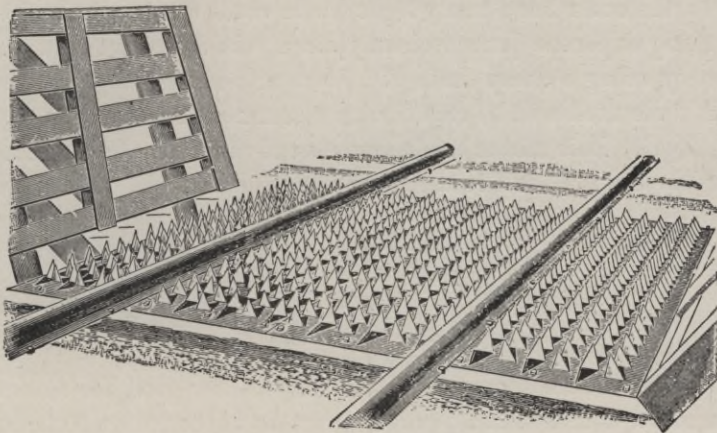

Fig. 81. Sheffield Cattle Guard.

across which the rails were supported on wooden stringers. But this form makes a break in the continuity of the roadbed and is a



very fruitful source of accidents. This form has, therefore, been definitely abandoned for "surface" cattle guards.

Two forms of these are illustrated in Figs. 80 and 81. The variations in the *surface* adopted are multitudinous. Usually they are made of iron, sometimes of wood and sometimes of some form of tile or cement which is not subject to decay or rust. Any form must have in addition the fences extending from the sides of the right-of-way up to the ends of the ties. These fences will be "headed" by a short guard fence, as shown in the left of each of the figures, which will prevent cattle from stepping over the end of the fence.

### TRACK AND TRACK WORK MATERIALS.

**104. Ballast.** The ideal ballast must transfer the applied load over a large surface; it must hold the ties in place horizontally; it must carry off the rain water and thereby prevent freezing up in winter; it must be such that the ties may be readily adjusted to the true grade line and it must produce an elastic roadbed. The various materials used for ballast fulfill these conditions in variable degrees and at various costs. The most perfect and costly ballast is not necessarily the best for a light traffic road, but on the other hand many light traffic roads are increasing their operating expenses (unconsciously) in a vain attempt to cut them down by using a cheap form of ballast or none at all. The principal kinds used will be stated with a comment on each one.

*Mud.* This means *no* ballast except the natural soil. Sometimes the natural soil is sandy or gravelly and will make a very

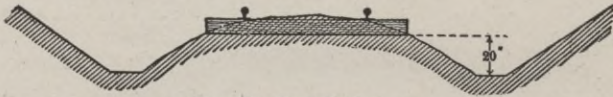

Fig. 82. Mud Ballast.

good ballast where it occurs, but no matter how good the soil may be in some places, such a quality cannot be depended on to be continuous throughout the line or even approximately so. Considering that a heavy rain will in one day spoil the results of weeks of patient "surfacing" with mud ballast, it is seldom economical to use it if there is a gravel bed or other source of ballast anywhere

on the line of the road. If it *must* be used, then the drainage should be exceptionally perfect. The earth should be crowned over the ties in the center and the ditches on each side should be at least 20 inches below the base of the ties. This will facilitate the flow of water to the sides.

*Cinders.* The advantages are an almost perfect drainage, ease of handling, and cheapness, for, after the road is in operation, their use is but the utilization of a waste product. The chief disadvantage lies in the dust produced as the particles are ground up by use. Incidentally, a light traffic road would require a long time to produce enough ashes to ballast the whole road, which would imply a long period of operation with no ballast at all.

*Slag.* In certain places such ballast is very cheaply obtained as a waste product, it being given away for the hauling. It is free from dust and the drainage is perfect.

*Shells, fine coal, etc.* These are only used when their proximity makes them especially cheap. They become dusty in dry weather and correspondingly imperfect in their drainage qualities. They soon become but little better than "mud."

*Gravel.* A large proportion of the railroad mileage of the country is laid with gravel ballast. This is because gravel beds are so frequently found on the lines of roads, from which the gravel



Fig. 83. Gravel Ballast.

may be dug with a steam shovel, loaded on to cars and hauled to any desired point where it is perhaps unloaded mechanically, the only strictly hand work in the whole operation being the tamping of the ballast in the track. Such methods make the cost per cubic yard very small. The gravel is easily handled and affords almost perfect drainage. If the gravel contains very fine stones or dirt, it should be screened over a half-inch screen to take the fine stuff out.

*Broken Stone.* This is the best form of ballast obtainable, and usually the most expensive. Although hand-broken stone is preferable, the cost of machine crushed stone is so much less that it is almost exclusively used. They should be broken so that they

will pass through a  $1\frac{1}{2}$ -inch or 2-inch ring. It is most easily shoveled with forks, and this method has the additional advantage that the finest chips and dirt will be screened out. Such ballast holds the ties more firmly than any other form and hence is almost an essential for roads handling a great and heavy traffic at high speed. For a light traffic road running few trains and these at very moderate speed, the use of rock ballast would be almost a useless luxury unless the broken stone were very cheap and gravel were expensive or unobtainable.

*Amount required.* Good practice requires a depth of 12 inches of gravel or broken stone under the ties. With 6-inch  $\times$  8-inch ties spaced 24 inches between centers, the amount between the ties will be equivalent to an additional depth of about 4 inches.

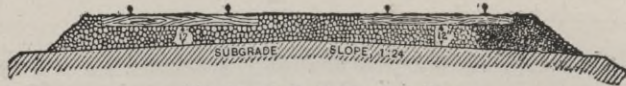

Fig. 84. Broken Stone Ballast.

If the ballast has an average width of 10 feet, say 8 feet at the top and 12 feet at the bottom, then one mile of track will contain 2,607 cubic yards. Broken stone requires a little more than this since there should be a shoulder of ballast on the ends of the ties. (See Fig. 84.)

*Method of laying.* When ballast is laid during the original construction of the road, the proper method is to haul the most of the ballast with carts or on the contractor's temporary track and spread it evenly to the level of the bottom of the ties. Then the ties and rails can be laid and a construction train can haul whatever ballast is required for surfacing and tamping. When the ties and rails are laid on the bare subsoil and the construction trains with ballast are run over it, the rails are apt to become badly bent and kinked. A compromise between the above methods is to use light construction cars which may run on the standard gauge track without doing the injury that would be caused by standard loaded rolling stock.

*Cost.* The cost of ballast depends on (a) the initial cost as it comes to the road, (b) on the distance from the source of supply to the place where used, and (c) on the method of handling. A

little thought will show the variation in these items for different roads, and therefore any estimates of cost are necessarily approximate. As an *average* figure the cost of broken stone ballast in the track may be computed as \$1.25 per cubic yard, and the cost of gravel may be put at 60 cents. The cost of placing and tamping gravel ballast is estimated at 20 to 24 cents, while the similar estimate for cinders is put at only 12 to 15 cents. The cost of loading gravel on cars, using a steam shovel, is estimated at 6 to 10 cents per cubic yard.

**105. Ties.** The cost of ties to a railroad is too apt to be superficially considered as the mere market price of the ties delivered to the road. The true cost is the cost of the maintenance of suitable ties in the roadbed for an indefinite length of time. The first cost is but one item in the total cost. A cheap tie must be soon renewed. The labor of renewal is a considerable item of cost. The renewal disturbs the roadbed, which requires adjustment to keep it from getting uneven. The unavoidable unevenness of the roadbed has an actual although uncertain effect on operating expenses, increasing the fuel consumption and wear and tear on the rolling stock. It even has some effect on possible or safe speed.

In round numbers, if the cost of buying and placing a good tie is twice that of a cheap tie, and the good tie lasts twice as long as the cheap tie, the economics of the cases are nearly equal. But on the one hand we have the interest on the *extra* cost of the good tie for the lifetime of the cheaper tie and on the other hand we have the additional cost of maintenance of way when using the poorer ties and the indefinite increase of operating expenses due to a poor roadbed. The annual cost of a system of ties should therefore be considered as the sum of (*a*) the interest on the first cost, (*b*) the annual sinking fund that would buy a new tie at the end of its life, and (*c*) the average annual maintenance for the life of the tie, which includes the cost of laying and the considerable amount of subsequent tamping that must be done until the tie is settled in the roadbed, besides the regular track work due to the tie. Such a method of comparison is essential in considering the economics of chemically treated ties and untreated ties.

*Wood.* A good tie must last as long as possible in the ground, must be hard enough not to be unduly affected by "rail-cutting,"

must be hard and tough enough to hold the spikes, and finally must be reasonably cheap. Throughout the United States some of the varieties of oak fulfill these conditions (on the whole) better than any other kind. Pine is the second choice, largely determined by its local cheapness. Cedar and chestnut come next, while redwood, cypress, hemlock, tamarack and a few others have a lesser use. Redwood and cypress are as good as any from the standpoint of mere decay, but they are so soft that the rails cut them and spikes have but little holding power. Since spikes must be driven within a very small area on the face of the tie (for the tie must be placed symmetrically under the rails), when a spike is partially pulled up by the rail tending to turn over, the spike must be re-driven very near its former position. On a curve there is a very great force tending to turn the rail over, and when the holding power of the spikes is not very great, they must be frequently re-driven. Forcing them down in the same hole is almost useless. It thus happens that a tie of soft but durable wood will be "spike-killed" long before any decay has set in. Redwood ties have been largely used in the West, and when they are protected by tie plates from rail-cutting, their life in a dry climate is very great, especially on tangents.

*Dimensions.* Ties for standard gauge roads are 8 feet, 8 feet 6 inches, and occasionally 9 feet in length. They should be 6 inches to 7 inches thick, and if sawed should be 8 inches or 9 inches wide. If they are hewed, they should have a hewed face of about the same amount. Sawed ties are a practical necessity on



Fig. 85.

trestles and bridges, and elsewhere they are preferable. When ties are cut from large timber, as is now frequently the case, sawing is a necessity, but there is a general opinion that hewed "pole" ties are more durable than sawed ties. In any case the bark should be entirely removed before they are laid.

*Spacing.* The most common spacing is 24 inches from center to center, which is the same as 15 per 30-foot rail, which is a common way of stating it. As many as 20 per 30-foot rail are sometimes used if the ties are small, but as this means only 18

inches from center to center, the space left for tamping is small and the support to the rail may be even less than that given by larger ties with wider spacing and more perfect tamping. The spacing should not be exactly even as more support is needed at the joints. Two ties are placed so that the rail joint is evenly supported by them. If the rail joints are "staggered," as is usual, two more joint ties are placed somewhat closer together near the middle of the opposite rail. The remaining ties of the allotment (say 15) per rail will be divided evenly in the remaining spaces.

*Rules for cutting.* It should be required that hewed ties should have their two faces truly parallel; the trees should be reasonably straight, one rule being that a straight line passing through the center of one end and the center of the middle shall not pass outside of the other end; they must not have severe splits or shakes; they should be cut in winter, or when the sap is down; they should be piled for at least six months before being used. When ties are furnished by farmers along the right of way, it is specified that the ties shall be neatly piled crosswise in piles on ground not lower than the rails, the piles to be at least seven feet from the rails.

*Rules for laying and renewing.* The largest and best ties should be reserved for joint ties. Whenever spikes are drawn out, the hole should be plugged with a wooden plug which will prevent water from settling in the hole and thus causing rapid decay. Ties should always be laid at right angles to the rail and never obliquely. When renewals are to be made, the requisitions are to be based on an actual count of ties to be renewed and not as the result of any wholesale estimate. It is unwise to use a mixed variety of ties in the track so that their size, elasticity and durability are very different. This will, by the variation in elasticity, cause rough riding.

*Cost.* Local circumstances very greatly affect the cost, even for the same class of ties. Railroads sometimes succeed in monopolizing the tie production in the territory through which they run by refusing to haul ties for any other customer or railroad, except at prohibitory rates, and control the price somewhat by refusing to pay more than the lowest limit at which the local people will



Fig. 86.  
Wooden  
Tie Plug.

supply the ties. The best ties procurable in a section can thus be procured for 45 to 50 cents per tie, and where common labor is very cheap this price is cut even to 25 cents. On the other hand, the very best of large oak ties will often cost 75 to 80 cents. In view of the above variation in price, any estimates must depend on local conditions.

**106. Rails.** The form of rail section popularly known as the A.S.C.E. section, was adopted by a committee of the American

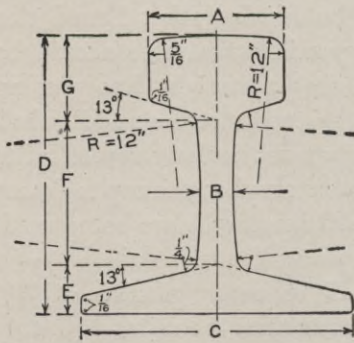

Fig. 87. Am. Soc. C. E. Standard Rail Section.

the A.S.C.E. section, was adopted by a committee of the American Society of Civil Engineers in 1893, after a great deal of discussion and study. That form is now used by the most of the railroads of the country. The numerical dimensions and angles shown in Fig. 37 are constant for all weights of rail. The letters indicate the variable dimensions, which are given in the following tabular form:

Dimension, in inches.	Weight per yard in pounds.												
	40	45	50	55	60	65	70	75	80	85	90	95	100
A	1 7/8	2	2 1/8	2 1/4	2 3/8	2 13/32	2 7/16	2 15/32	2 1/2	2 9/16	2 5/8	2 11/16	2 3/4
B	2 5/16	2 7/16	7/16	15/32	3 1/16	1/2	3 3/16	1 7/16	3 5/16	9/16	9/16	9/16	9/16
C & D	3 1/2	3 11/16	3 7/8	4 1/16	4 1/4	4 7/16	4 5/8	4 13/16	5	5 3/16	5 3/8	5 9/16	5 3/4
E	5/8	2 1/16	1 1/16	2 3/16	4 9/16	2 5/16	1 3/16	2 7/16	7/8	5 7/16	5 9/16	1 5/16	3 1/16
F	1 5 1/16	1 3 1/16	2 1/16	2 1 1/16	2 7 1/16	2 3/8	2 1 1/16	2 3 5/16	2 5/8	2 1/4	2 5 5/16	2 3 1/16	3 5 1/16
G	1 1 1/16	1 1 1/16	1 3/8	1 1 1/16	1 7 1/16	1 9 1/16	1 1 1/16	1 2 7/16	1 1/2	1 3 5/16	1 1 3/8	1 4 1/16	1 4 5/16

About 1909 the American Railway Engineering Association proposed two types of sections (A and B). Series A is designed to meet the wishes of those who desire a rail with a comparatively thin head and high moment of inertia, and series B for those who believe that the head should be narrow and deep and that the moment of inertia is comparatively unimportant. The radius of the upper corner of the head is increased from 1/4" to 3/8". The side of the head, instead of being left vertical, has a flare of 3° 35' for the A type and 3° for the B type. In 1914, the Rail Committee reported

that the A.S.C.E. sections were still extensively used and apparently had not been largely replaced by the proposed new sections.

The feature in rail design which has excited the most discussion is the radius of the upper corners of the head. Rail wear begins there and rails with sharp corners will wear longer than those with

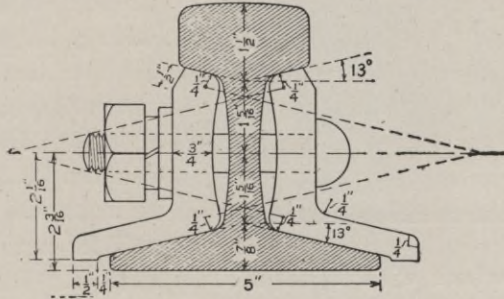

Fig. 88. Rail Joint.

larger radii. The rapidity of the rate of rail wear after the corner has worn off is one proof of this, and so from the maintenance of way standpoint sharp rail corners are desirable. But excessively sharp rail corners produce excessive wear on the flanges of the wheels, not only wearing out the wheels quickly but even rendering them dangerous and liable to cause a derailment. The compromise of  $\frac{5}{16}$ " radius, adopted in the A.S.C.E. design, was increased to  $\frac{3}{8}$ " in the A.R.E.A. design.

*Weight.* The weight of rail that should be used on any road is an exceedingly important financial and technical question. It is the largest single item of expenditure in the construction of a road, and the temptation to cut down the item by 5 per cent or 10 per cent is very great. For all ordinary sizes the price per ton is uniform, and therefore a reduction in weight per yard means a corresponding reduction in the cost. But it should be considered that what is desired is a rail that has *stiffness* and *strength*, no matter how much it weighs.

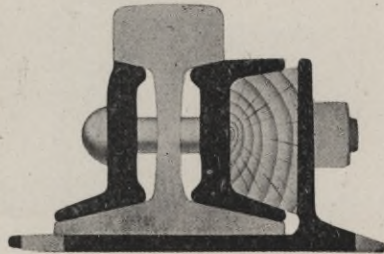

Fig. 89. Weber Rail Joint.



It can readily be proved that if all sizes of rails had exactly similar cross-sections (which is nearly true) then the stiffness of a rail varies as the *square* of the weight and the strength varies as the  $\frac{3}{2}$  power. This means that if we add 10 per cent to the

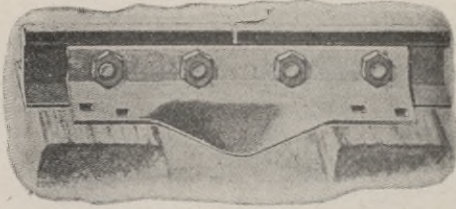

Fig. 90. Bonzano Rail Joint.

weight (and therefore to the cost) of the rail we are adding 21 per cent to the stiffness, and over 15 per cent to the strength. As a more concrete example, suppose that some desire to make the weight of the rail for a road 60 lb. per yard, and others wish to use a 70-lb. rail. At \$30 per ton (of 2,240 pounds) the *difference* of cost will be \$471.42 per mile of single track. But on the other hand, although the cost is increased by  $16\frac{2}{3}$  per cent, the strength is increased 26 per cent, and the stiffness is increased 36 per cent. The increase in stiffness is more than double the increase in cost. Unfortunately there is no absolute criterion as to the amount of stiffness or strength required since it depends largely on the unknown, uncertain and variable tamping of the ties and the support which the ties receive from the ballast. But the above *relative* figures hold good, and considering that a stiff track means decreased rolling resistance, higher

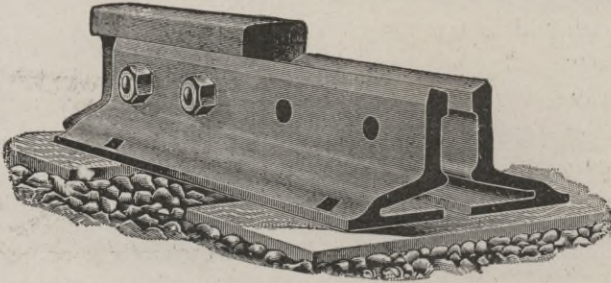

Fig. 91. Continuous Rail Joint.

speed and greater safety, a considerable increase in weight over that minimum on which it would be possible to run trains is not only justifiable but is a measure of true economy. As a general statement, it may be said that 60 lb. per yard is the lightest

weight which should be used on a standard gauge road running ordinary rolling stock, no matter how light the traffic. Roads with a fair business should have 70-lb. rails. The great trunk lines are relaying with 100-lb. rails on the heavy traffic divisions, and usually have as heavy as 85-lb. rails on all but the small branches.

*Length.* The standard specifications proposed by a committee of the American Railway Engineering and Maintenance of Way Association in 1902 contained this clause: "The standard length of rails shall be 33 feet. Ten per cent of the entire order will be accepted in shorter lengths, varying by even feet down to 27 feet. A variation of  $\frac{1}{4}$ -inch in length from that specified will be allowed."

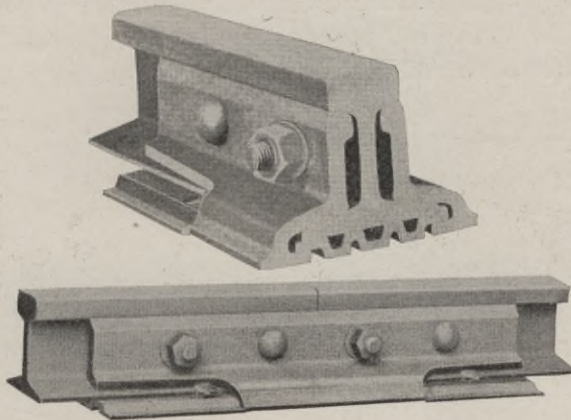

Fig. 92. Wolhaupter Rail Joint and Section Through Center.

During late years much experimenting has been done with the idea of increasing the length of rail, and a considerable amount of rails of 45 and even 60 feet has been laid. These have the undoubted advantage of saving a proportionate number of rail joints, which are always a source of trouble, but at the same time the allowance for expansion which must be made at every joint must be proportionately increased. The above recent standard specification apparently indicates that the increase in length has not proven desirable.

**107. Rail Joints.** The action of a heavy wheel rolling on an elastic rail is to cause a wave of elasticity to run in front of the point of contact. A perfect track is one that will keep that wave of elasticity perfectly uniform, which requires that the rail joint

should have the same strength and stiffness as the rail. Only a welding of the rails, making them continuous, would accomplish this. Any rail joint which is as strong as the rail is necessarily much heavier and stiffer. Passing by the older forms which have now become obsolete, we have in Figs. 88 to 93 the forms which are now competing for adoption. The "angle bar" is still used more than any other kind, but many of the other forms have demonstrated their reliability and fulfilment of the requirements as nearly as may be hoped for. Nearly all of these designs are used exclusively as "suspended" joints rather than as "supported" joints, the difference being, as the name implies, that a suspended joint is placed between two ties so that each end of the joint has an equal bearing on the ties; a supported joint is set directly over a tie and hence must get practically its whole sup-

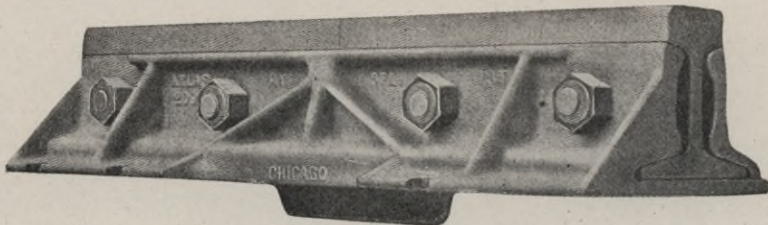

Fig. 93. Atlas Suspended Rail Joint.

port from that one tie, unless the joint is so long that it rests on the adjacent ties, thus making it a "three-tie" joint.

Angle bars are usually about 26 inches long. Of course, the bars, of whatever kind, should be so made that they will fit closely under the head of the rail and also have a close fit on the top of the flange. This means that every rail joint must be made with special reference to the particular design of rail with which it is to be used and that it will fit no other design. For the smaller sizes of rails and on light traffic roads, four-bolt angle bars are used, but the longer and heavier bars are usually made with six holes. The holes are made in a somewhat elliptical form and the track bolt has a corresponding form immediately under the head. The bolt is thus prevented from turning when the nut is screwed on or off. The holes in the rail are made about  $\frac{1}{4}$  inch larger in

diameter than the bolt. This is to allow room for expansion of the rail due to temperature.

*Insulated Joints.* Rails are very frequently used to form an electric circuit as part of the system of signaling. As an item in the system it is required that certain joints shall be so made that no current shall pass between adjacent rails. This requires the use of insulated joints. A plate of some insulating material is placed between the ends of the rails and even the joint bars, of whatever kind, must be made of wood, or if of metal must have the metal insulated from the rails. One form of such a joint is illustrated in Fig. 94.

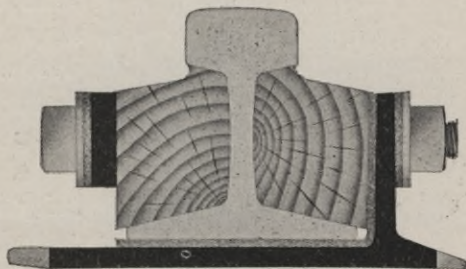

Fig. 94. Insulated Joint for Track Circuit.

**108. Tie Plates.** Many of the soft-wood ties are very durable as regards decay, but are "cut" by the rail very badly. This is not due to mere static pressure but to the working of the rail on the tie during expansion, and to impact when the rail has become loosened somewhat from the tie and a wheel load suddenly forces it down with a hammer blow. The cutting on curves is also due to the excessive pressure produced by the edges of the flanges which is developed by the centrifugal action of the rolling stock. Another advantage in the use of tie plates lies in the fact that the spikes are mutually supported; a spike cannot be forced laterally in the tie without drawing the tie plate with it and this is resisted by all the spikes passing through the tie plate. The cost is insignificant compared



Fig. 95. Tie Plate.

with the added life of the tie, especially if it is a soft wood tie. The advantage with an oak tie is not so great proportionally.

It is very important that the spikes should fit the spike holes with but very little play, otherwise one of the primary objects of the plate will be defeated, and the rail will not be secure against

lateral motion. Note that the flanges on the lower side of the plate not only stiffen it and make it much stronger structurally but they also secure the plate to the tie and prevent an objectionable rattling. The very presence of these flanges, however, requires that the plates shall be pressed or hammered on to the tie

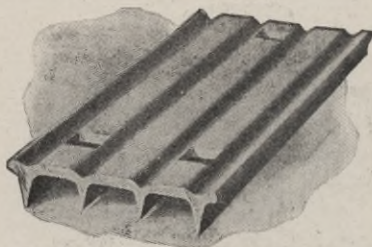

Fig. 96. Wolhaupter Tie Plate.

until the flanges penetrate to their full depth. This may be done with a heavy maul but it is best done by utilizing the hammer of a pile driver.

Notwithstanding the popularity of flanged tie plates, several up-to-date roads are using only tie plates with flat bottoms, claiming that the punctures made by the flanges hasten decay or crushing under the plate, which is avoided with flat plates. A flat plate, designed for use with screw spikes (note the round holes) is shown in Fig. 97.

**109. Rail Braces.** The pressure against the outer rail on a curve, and also the pressure against the inner rail when a train stops on a curve which has a considerable super-elevation, is frequently provided for by "rail braces" such as are illustrated in Figs. 99 and 100.

Sometimes these are made of cast iron, but these are brittle and are apt to be broken by a blow from a spike maul when the spikes are driven.

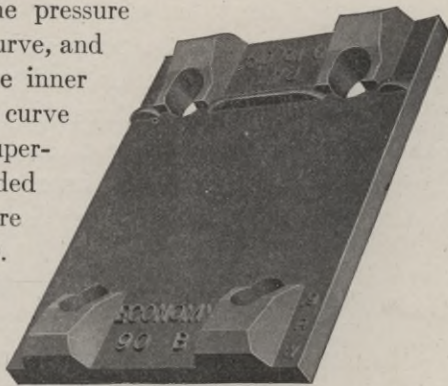

Fig. 97. Economy No. 9 RW

The preferable form, although it is more expensive, is to forge them or "press" them from wrought iron or steel. In Fig. 100 is shown a form which has a plate which runs under the rail which thus makes it a combined rail brace and tie plate.

**110. Spikes.** The fundamental requirement of a spike is holding power, but it must also be cheap, easily applied, and easily removed when necessary. It has been found that mak-

ing the surface rough and even jagged, decreases rather than increases the holding power, and also destroys the fibre of the wood. The best form is a spike with plane and smooth faces. The point should be made so as to *cut* the fibres of the

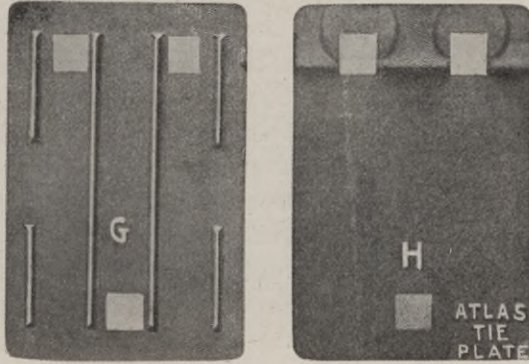

Fig. 98. Atlas Tie Plate.

wood instead of crushing them. By this means the fibres are pressed outward and downward, and thus any upward pull only tends to draw the fibres back to their original place and so increase the pressure against the spike and thus increase the friction and the holding power. The standard spike for rails weighing more than

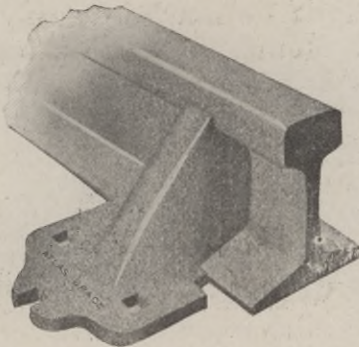

Fig. 99. Atlas Brace KK.

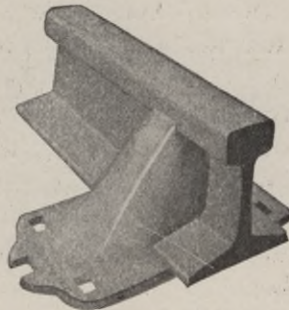

Fig. 100. Atlas Brace K.

56 pounds per yard is  $5\frac{1}{2}$  inches long and  $\frac{9}{16}$ -inch square. There will be about 375 in a keg of 200 pounds. On this basis, if the ties are 24 inches apart and four are used per tie, there will be required 5,632 spikes per mile or 28.16 kegs. Of course a consider-

able allowance must be made for loss and waste of various kinds.

**111. Track Bolts.** The track bolt must have sufficient strength to hold the angle plates together with such force as will develop the full strength of the angle plates. And yet this must

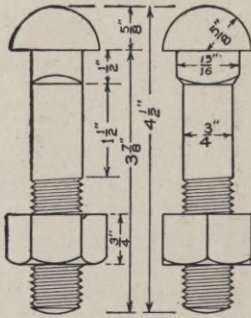

Fig. 101. Track Bolts.

be accomplished so that the friction developed will not be so great that the rails may not slide in the joints during temperature changes. On a straight track the contractive pull due to a fall of temperature is so great that no possible gripping of the bolts could prevent slipping, but it is quite possible that when rails expand, and especially when on a curve, the resistance to slipping might be so great that the track would bulge out of alignment instead of slipping at the joints. Such an effect does actually

take place when the allowance for expansion is insufficient and the rails continue to expand after they have butted end to end.

Another requirement is that the bolts shall not turn while the nut is being turned. This is accomplished by an enlargement of the bolt just under the head, as shown in Fig. 101. This fits fairly closely in a corresponding oval-shaped hole in the angle plate. The sizes shown in the figure are about what should be used with a 70 or 80-pound rail. Heavier rails require a longer bolt and one that is proportionately heavier. The type of rail joint used, and also the type of nut lock if any, will determine the required length of bolt, while the weight of rail should determine the diameter. The diameters vary from  $\frac{3}{4}$  inch to 1 inch, and the lengths from 3 inches to 5 inches.

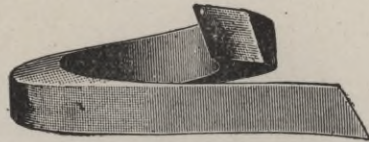

Fig. 102. Ajax Tail Washer.

**112. Nut Locks.** There are three types of nut lock—(a) those which have an elastic cushion under the nut which absorbs the vibrations that would otherwise loosen the nut, (b) those by which the nut is made to grip the bolt (by some unusual device) so that vibration will be insufficient to loosen it, and (c) the “positive” type, in which the locks are pre-



VIEW OF KANSAS CITY UNION RAILROAD STATION





vented from turning by some definite and positive mechanical check.

The "Ajax Tail Washer," shown in Fig. 102, is a sample of the first class, although it also has some of the elements of the third class, since the sharp steel points will tend to bite into both the under side of the nut and the side of the angle plate where it rests whenever there is a tendency for the nut to turn backward. These points merely drag and slip when the nut is being tightened.

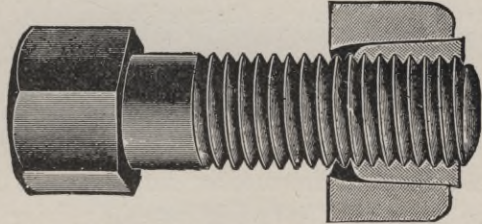

Fig. 103. Columbia Nut Lock.

The Columbia nut lock, shown in Fig. 103, is a sample of the second class. The nut is compound, the inner piece being a four-sided frustum of a pyramid, the edges being rounded. This fits into a corresponding recess in the outer piece. The inner piece is also cut through so that it may be slightly squeezed together. The pyramidal form requires both pieces to turn together. When the outer piece comes in contact with the angle plate it is forced back (relatively to the inner piece) which squeezes

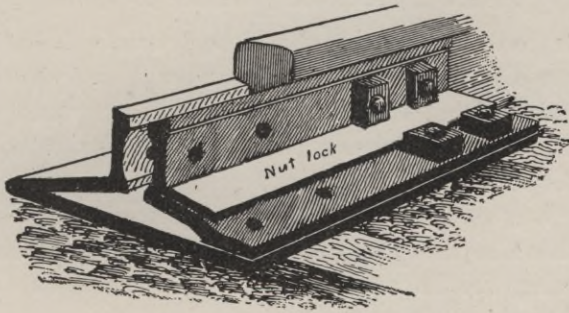

Fig. 104. Gordon Nut Lock.

the inner piece together and causes it to grip the bolt. The more the nut is turned, the tighter the grip.

The Gordon nut lock, shown in Fig. 104, is a sample of the third class, although it is designed to be used only with the form of angle plate which is shown. In the form shown the square

nuts must be turned until one edge is exactly on line. A one-eighth turn forward or back will always accomplish this. Thus when the bar is slipped in all nuts are absolutely prevented from turning. The above designs have been selected as mere samples of each class from a great multitude of designs of greater or less merit which are on the market.

### LAYING TRACK.

**113. Surveying.** After the earthwork is completed and the culverts and bridges are built, the center line of the track must be re-located on the roadbed surface of the fills and cuts. Reference points should have been established during the original survey so that by the intersection of two radii swung from permanently established points the beginnings and endings of all curves may be re-located. Then all intermediate stations should be filled in. A line of levels should then be run and the agreement of these



Fig. 105. Right and Wrong Method of Laying Ties.

levels with the designed grade should be determined. If the levels of the cuts and fills has been followed with sufficient closeness during construction, there should be no discrepancy except that the levels of fills should be somewhat higher than that called for so as to allow for subsequent settlement.

**114. Laying Ballast.** This has already been discussed in §104, as has also the policy of laying the ties and rails first and then drawing the ballast in a construction train on the poorly supported track.

**115. Laying Ties.** If the ties have been sawed to an exact length, the alignment of one end will of course line up the other but when ties have been hewed and chopped off and sometimes even when they have been sawed, there is a range of several inches in their length and then it is required that they shall be aligned at one end or the other. A little stick may be furnished the track-

men as a spacer, but with a little experience they will space the ties as closely to the required spacing as is necessary. The ties should always be laid with rings convex upward rather than concave. Of course a pole tie, when it is perfectly symmetrical, will be the same either way, but there is usually a choice, as is shown by the figure. When the rings are concave upward there is a greater chance for water to soak in and cause decay. Turning the tie the other way, the water will shed off more freely.

**116. Laying Rails.** Rails should be laid so that the joints are staggered as nearly as possible. This requires a half-rail length at the start. But the difference of length of the outer and inner rails of a curve will disturb the arrangement of the joints, no matter how perfectly it may start. These differences may be neutralized by selecting rails which are a foot or two shorter than the usual length. But the occurrence of a switch will require a readjustment of the joints, and may require a rail cutting so as to bring a joint where desired. Very short lengths of rail should be avoided. If a full length rail comes a few feet short of a point where a joint *must* be made, it should be cut so that both pieces shall have a fair length. The rails are first laid approximately in position and end to end.

When placing the joints on the rails, allowance must be made for rail expansion due to temperature. The theoretical amount to be allowed is .0000065 of the length for each degree Fahrenheit. If it could be readily determined just what is the temperature of the rail (which is possibly much higher than that of the air) at the time the rail is laid and also the highest and lowest temperature that it will ever attain, the problem would be comparatively simple, but the fact that these quantities are so uncertain seem to render useless any attempt at an exact calculation and to justify the rough and ready rule of "allowing  $\frac{5}{16}$  inch for coldest weather,  $\frac{1}{8}$ -inch during the spring and fall, and  $\frac{1}{16}$ -inch during the very hottest weather." The allowance of  $\frac{1}{16}$ -inch during the very hottest weather is apparently based on the idea that the rails should never be allowed to butt up against each other, for then any additional expansion will cause the rails to buckle. If a rail was laid when its actual temperature was 60° F., its length of 33 feet would be increased by about  $\frac{1}{8}$  inch if its temperature were raised to

120°, as might readily happen under a burning summer sun when the temperature of the air in the shade was perhaps 100°. A practical method of making an allowance which would be sufficiently accurate would be as follows: Place a bulb thermometer (one without a metal frame) so that the bulb lies against the rail and then cover it up so as to protect it from the air and so that it will assume the temperature of the rail as closely as possible. The expansion of a 33-foot rail for each degree is

$$.0000065 \times 33 \times 12 = .002574 \text{ inch.}$$

If we allow 120° (some allow 150°) as the maximum beyond which it is assumed that the temperature will never rise, then the difference between this maximum and the ascertained temperature of the rail, when multiplied by the above allowance per degree, equals the gap to be allowed at each joint. Strips of sheet metal of the required thickness should be furnished to the trackmen. These strips are placed temporarily between the rail ends which obviates any necessity for measuring on their part. When the joints have been bolted up, one line of rails is spiked so that they are at the proper distance from the ends of the ties. Then by using a "track gauge" at every other tie the other line of rails may be spiked down. The intermediate ties are then spiked. "Standard" gauge, which is in almost universal use in this country, is 4 feet 8½ inches = 4.708 feet. Although the gauging should be all right for these other ties, the gauge should be at hand to check the previous work, especially if it is on a sharp curve. Track instructions frequently specify that rails should be previously bent before laying around curves, or in other words, that the rails should have the proper curve when lying freely on the ties. Of course the necessity for this increases with the degree of curvature, it being unnecessary for very easy curves.

The practical trouble comes at the joints; the rails instead of having a common tangent will intersect at an angle which is destructive both to the track and the rolling stock when trains are run at high speed. The ideal method is to have the rail bending done by rollers in a rolling mill and this method is almost a necessity for the very sharp curvature employed on some electric roads. The field method is to use a "rail bender" which bends the rail in

lengths of about two feet and which must be operated very carefully and skilfully to avoid ruining the rail. A rail is bent until, when a string is stretched from the inside of the head at one end to the inside of the head at the other end, the distance from the middle point of the string to the inside of the head at the middle of the rail is as computed below:

In Fig. 106, since the triangles AOE and ADC are similar,  $AO : AE :: AD : DC$ , or  $R = \frac{1}{2} AD^2 \div x$ . When as is usual, the arc is very short compared with the radius,  $AD = \frac{1}{2} AB$  very nearly. Making this substitution, we have

$$R = \frac{\text{chord}^2}{8x} \quad (\text{very nearly}) \quad (54)$$

Inverting the formula we have the formula required for present use:

$$x = \frac{\text{chord}^2}{8R} \quad (\text{very nearly}) \quad (55)$$

Although not mathematically accurate, the maximum error in any practical case is far within the attainable accuracy using a string.

**Example.** What should be the middle ordinate for the outer rail (33 feet long) for a 6 degree curve? We will call the chord 33 feet since the slight inaccuracy involved only tends to neutralize the inaccuracy of the formula.  $R = 955.37 + 2.35 = 957.72$ . Then  $33^2$  (which equals 1089) divided by  $(8 \times 957.72) = .142$  foot or 1.70 inches. If a similar calculation is made for the inside rail the difference in the ordinate is less than .01 inch, which shows that unless the curvature is excessively sharp there is no need to make the allowance for half-gauge (2.35, as is done above) nor even to use great accuracy in the decimals. A table giving the middle ordinates for 33-foot rails for different degrees of curvature is a desirable part of the equipment of each track foreman.

The spikes on the opposite sides of a rail should be driven "staggering," so that there will be less tendency to split the tie. The direction of the staggering should be reversed at the two ends of the tie, so as to prevent a loosening of the hold of the spikes,

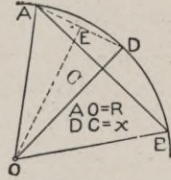

Fig. 106.

such as would occur if the reverse method were used and the tie were to become displaced and not perpendicular to the rails. Such an item of construction, while very simple, is of vital importance.

**117. Surfacing.** Track centers (stakes) having been placed in line, the alignment of the track is made perfect. The rail laying should have been done with the rails a few inches below their proper grade. Then jacks are placed under the ties (or rails, as most convenient) and the track is raised to grade, as given by grade stakes which should have been previously set. Using tamping picks or shovels, the ballast is jammed under the ties until they are solid at the desired grade. Picks or tamping bars are best for tamping broken stone ballast, but gravel can be most easily tamped with shovels.



Fig. 107. Trip Ballast Gang Jack.

**118. Super-elevation of the Outer Rail on Curves.** It is one of the demonstrations of physics that the force required to make a mass move in a circular path equals  $Gv^2 \div gR$ , in which  $G$  is the weight,  $v$  the velocity in feet per second,  $g$  the acceleration of the force of gravity in feet per second in a second, and  $R$  the radius of curvature. If the rails on a curve were level transversely, such a force could only be furnished by the pressure of the wheel flanges against the rail. To avoid this objectionable pressure, the outer rail is elevated until the inward component of the inclined wheel pressure equals the computed centripetal force required.

In Fig. 108,  $ob$  may represent the resultant pressure on the rails at the same scale at which  $oc$  represents the weight  $G$ . Then  $ao$  is the required centripetal force. From similar triangles, we may write  $sn : sm :: ao : oc$ . Call  $g = 32.17$ . Call  $R = 5730 \div D$ , which is sufficiently accurate for the purpose. Call  $v = 5280V \div 3600$ , in which  $V$  is the velocity in miles per hour.  $mn$  is the distance between rail centers, which for an 80-lb. rail and standard gauge is 4.916 feet;  $sm$  is slightly less than this. As an average value, call it 4.900, which is its exact value when the super-elevation is  $4\frac{3}{4}$  inches. Calling  $sn = e$ , we have

$$e = sm \frac{ao}{oc} = 4.9 \frac{Gv^2}{gR} \frac{1}{G} = \frac{4.9 \times 5280^2 V^2 D}{32.17 \times 3600^2 \times 5730}$$

$$e = .0000572 V^2 D \quad (56)$$

Studying the above formula, it will first be noticed that the required super-elevation varies as the *square* of the velocity, which means that a change of velocity of only 10 per cent would require a change of super-elevation of 21 per cent. Since train velocities over any road are so very variable, it shows that it is impossible to make any super-elevation fit all trains even approximately. There are several approximations in the above formula, but none of them will affect the result as much as a change of less than one per cent in the velocity.

**Practical Rules.** A very simple and commonly used rule is to elevate one inch for each degree of curvature. This rule agrees with the above formula when the velocity is about 38 miles per hour. If a train is running slower than the speed for which the super-elevation was designed, the practical effect is to relieve the pressure against the outer rail which still exists in spite of super-elevation on account of the necessity of turning the groups of four or six wheels under a truck or engine. Therefore the better plan is to elevate for the fastest trains. Thirty-eight miles an hour is so near the maximum for a light traffic branch line, that the above rule is very fair, although, of course, not so good as a more accurate one.

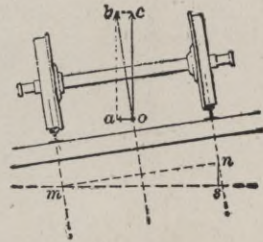

Fig. 108.

Another rule, which is especially good for track maintenance when the track foreman may not even know the degree of curve, is developed as follows: Assume that  $x$  in equation 55 is equal to  $e$  in equation 56, and we have

$$\frac{\text{chord}^2}{8R} = .0000572 V^2 D$$

but since  $D = 5730 \div R$ , we have

$$\text{chord}^2 = 2.621 V^2 \text{ and}$$

$$\text{chord} = 1.62 V$$

(57)



Assume that the limit of 50 miles per hour is set as the speed of the fastest trains, then  $chord = 1.62 \times 50 = 81$  feet. This means that if a string or tape, having a length of 81 feet, is stretched between two points at that distance apart on the inner head of the outer rail, the length of the ordinate at the middle of the string equals the required super-elevation for 50 miles per hour. Similar computations can be made and tabulated for all other desired speeds. On double track, since the speed on an ascending grade will almost certainly be less than the speed of trains coming down that grade, there should theoretically be a difference in the super-elevation to allow for this difference of speed. On some roads the track instructions contain specific instructions to allow for this.

### SWITCHES AND TURNOUTS.

**119. Switch Construction.** The universal method of keeping the wheels of railroad rolling stock on the rails is to put

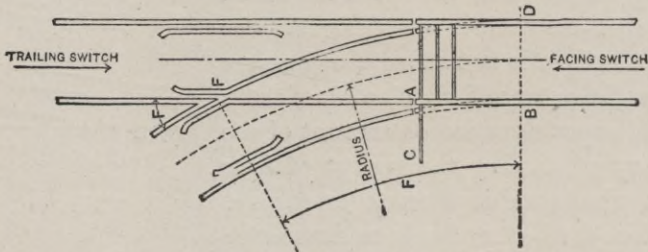

Fig. 109. Stub Switch.

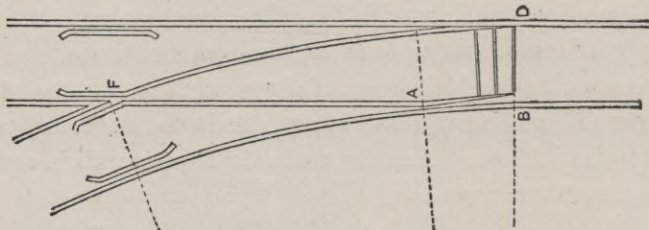

Fig. 110. Point Switch.

flanges on the inner edges of the wheels. When the wheels are to be led away from the main track, it must be done by creating a new pathway for these flanges. This is done by leading the wheel flanges *through* the rails or by raising the wheels sufficiently so

that they may pass *over* the rails. Both methods will be described. The method of leading the flanges through the rails is most commonly used since it does not require *raising* the rolling stock over the rail.

When the rails are first led out from the main track, it must be done by one of two general methods, the stub-switch method, illustrated in Fig. 109, or by the point-switch method, illustrated in Fig. 110. Of course these figures are only diagrammatic and it should be at once understood that in these figures as well as in many others in this chapter, it has been necessary to use very short radii, very wide gauge, and very large frog angles in order

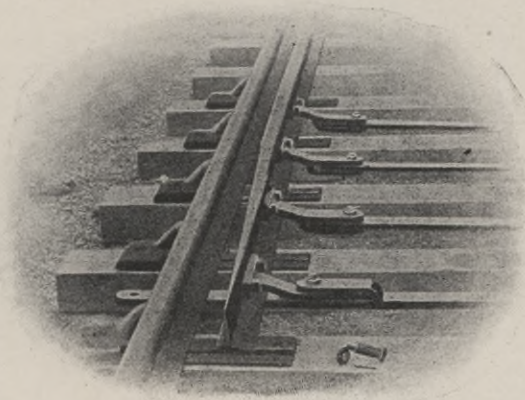

Fig. 111. Details of Point Switch.

to illustrate the principles by figures which are suitable for the page and which would at the same time be intelligible.

The use of the stub switches is now confined to the cheapest of yard work or private switches which run off from sidings. They should never be used in any main track. Their construction may be implied from Fig. 109. The pair of movable rails are tied together at the proper gauge by tie rods. The two pairs of stub ends are of course fixed. The details of a point switch are illustrated in Fig. 111. Note that one rail on each side is absolutely unbroken. The other rail has nearly all of the head cut away and a part of one flange. The other flange and the web, with that part of the head immediately over the web still remains. The tie rods which are clearly shown connect this pared-down rail with a

similar rail on the other side. The last tie rod has an extension to which the switch rod from the switch stand is attached. The moving rail slides on tie plates which have rail braces on the outer ends which stiffen the rail against the unusual lateral strain to which it is subjected. The angle of these switch points varies from  $0^{\circ} 52'$  to  $2^{\circ} 36'$ .

*Switch Stands.* One type of switch stand, which also combines a semaphore (or signal which shows its position) is shown in

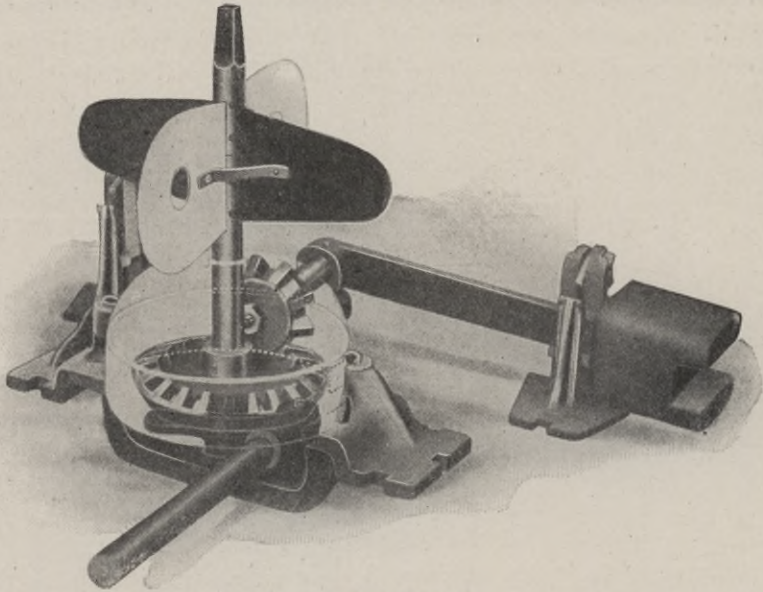

Fig. 112. Switch Stand.

Fig. 112. The mechanism is of course covered, the cover being indicated by the faint lines. The type shown is but one of a multitude for which there is no space here.

*Guard Rails.* These are shown opposite the frogs in both Figs. 109 and 110. They obviate any danger of the wheel running on the wrong side of the frog point and also save the frog point from excessive wear. The flange-way space between the heads of the guard rail and the wheel rail must therefore not exceed a definite quantity, which is made about two inches. Since this is less than the distance between the heads of two ordinary sized rails when placed base to base, to say nothing of any space

for spikes, the base of the guard rail must be cut away somewhat. These guard rails are made from 10 to 15 feet long and are bent a few feet from each end so that there shall be no danger that a wheel flange shall strike the ends.

*Frogs.* When the outer switch rail reaches the opposite main rail, the wheel flange must either pass *through* the head of the main rail or the wheel must be raised so that the flange may pass over the rail. The most commonly used frogs are those of the type of which the wheel flange passes through the head of the rail. The geometrical outline of such a frog is shown in Fig. 113.

The frog *number* may be found by dividing the distance from the "point" to any chosen place by the width of the frog at that place, or in the figure  $ch \div ab$ . But since  $c$  is the imaginary intersection of the sides produced and is not easily determinable with accuracy on the frog, it is sometimes easier to measure the

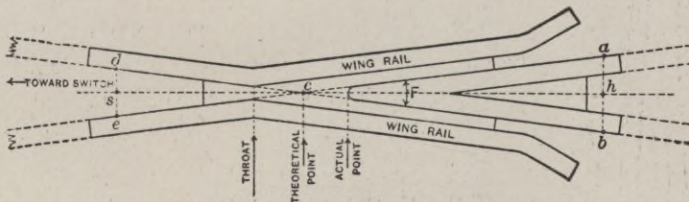
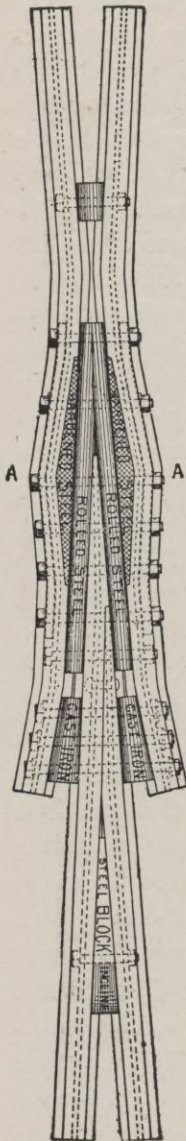

Fig. 113. Diagram of Frog.

width at two places ( $ed$  and  $ab$ ) and then divide the sum of those widths by the total distance  $sh$ ; this will give the same result as before. This measuring may be done with any convenient unit of length such as a pencil or a spike. Find the place where the width of the frog just equals the unit of length and then step off that distance to the "point." The fundamental objection to all frogs of this type is that they make a break in the main rail which causes a jar when a train is run over the frog at high speed. If the frog is made "stiff" as is illustrated in Fig. 114, the track has the advantage of being literally *stiff*, but the wheels have to run over the gap. The design shown in the figure aims to obviate any drop of the wheel at any point and this will be fairly accomplished as long as the hardened steel faces can resist the wear which is very severe in the older and commoner designs.

The "spring-rail" frog, illustrated in Fig. 115, is an attempt to obviate the gap for main line trains. Wheel flanges running on to the switch force back a portion of the main track rail which is normally held in place by a heavy spring. Running on to the switch is supposed to be done at comparatively slow speed, which permits the rail to be forced back without danger of derailment. But since the main rail is kept in place by the pressure of a spring, the frog lacks the stiffness of a "stiff" frog. The method of raising the wheel and carrying it over the main rail is illustrated in Fig. 116, which shows one of the many devices to accomplish this end. The method has the very positive advantage of leaving the main track absolutely unbroken.



In Fig. 117 is shown a method of avoiding a break even at the switch. The switch rails are at the level of the main rails at the switch point but gradually rise higher until the wheel flange is high enough to cross over the main rail. Such a switch must be operated at slow speed.

**120. Mathematical Design.** In all of the following demonstrations, the track lines represent the gauge lines or the lines of the inside head of the rails. The older formulæ, which are still in extensive use on account of their simplicity, all assume that the switch rails are bent to arcs of simple curves extending from the switch point to the frog, and that they are tangent to

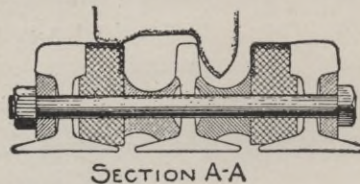

Fig. 114. Anvil-face Frog.

the main rails at the switch point. On account of its common use and also because it forms a fitting introduction to the more

exact method, it will be given. In all of the following demonstrations, the following notation will, for simplicity, be kept uniform.  $R$  will represent the radius of curvature of the main track, if it is curved, and  $r$  is the radius of the switch rails.  $F$  will always represent the frog angle, and  $g$  the gauge of the track.  $L$  will represent the "lead" or the distance measured on the main track from the switch point  $B$  to the frog point  $F$ .

The angle  $FOD$  in Fig. 118 equals the angle  $F$ , and  $BD$  is the versed sine of  $F$  to the radius  $FO$ . From this relation we may derive the equation

$$r + \frac{1}{2}g = \frac{g}{\text{vers } F} \quad (58)$$

also, since  $BF \div BD = \cot \frac{1}{2}F$ ,  $BD = g$  and  $BF = L$ , we have

$$L = g \cot \frac{1}{2}F \quad (59)$$

Also,

$$L = \left( r + \frac{1}{2}g \right) \sin F \quad (60)$$

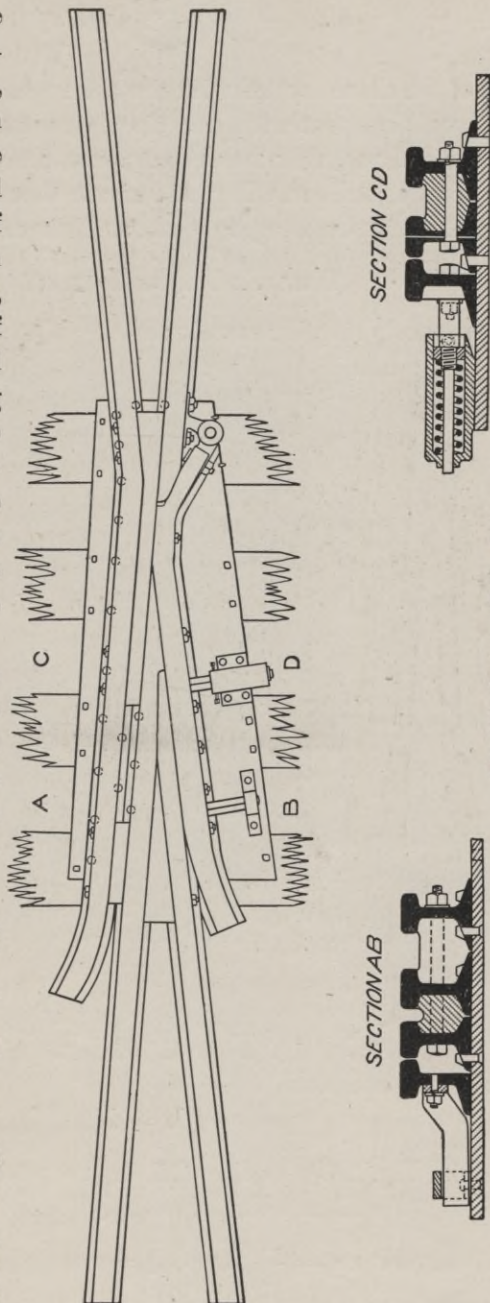

Fig. 115. Spring-rail Frog.

and 
$$QT = 2r \sin \frac{1}{2} F \quad (61)$$

All of the above formulæ involve the angle  $F$ . Reference to Table III\* will show that with one chance exception the values of  $F$  are always odd and the accurate computation of their trigonometrical functions is tedious. Fig. 119 shows that the ratio of the length to width of a frog, or  $pc \div ab$ , which is called  $n$ , is also equal to  $\frac{1}{2} \cot \frac{1}{2} F$ . This relation can be used to derive the following marvellously simple formulæ:

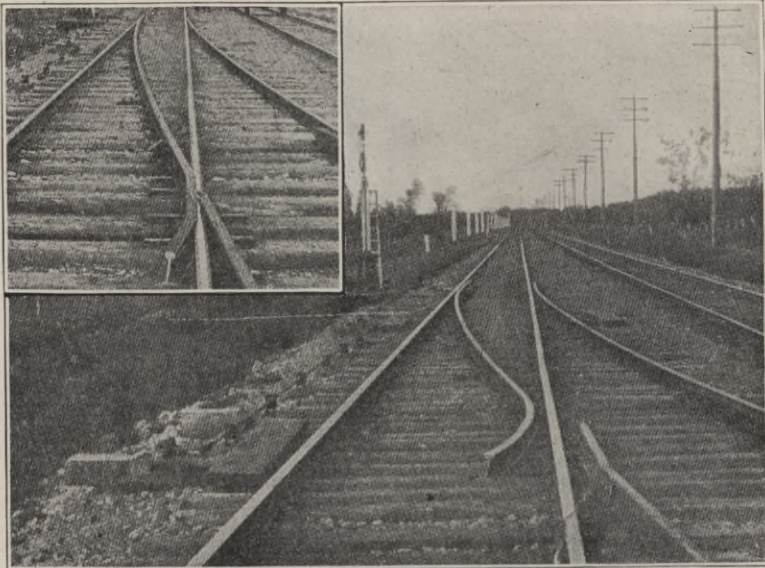

Fig. 116.

Since  $L = g \cot \frac{1}{2} F$ , and  $n = \frac{1}{2} \cot \frac{1}{2} F$ , we may at once derive the equation

$$L = 2gn \quad (62)$$

But in Fig. 120 the line  $QZ$ , drawn midway between the rails, bisects  $DF$  at  $Z$  and also, since  $DQ$  is one-half of  $DB$ ,  $QZ$  is one-half of  $BF$  or  $= \frac{1}{2} L$ .  $OQ = r$  and the angle  $ZOQ = \frac{1}{2} F$ .

\*See Webb's "Trigonometric Tables," published by American School of Correspondence, Chicago, Ill. Price, 50c.

Then  $r \div \frac{1}{2} L = \cot \frac{1}{2} F$ , from which

$$r = nL \quad (63)$$

Combining equations 61 and 62, we have

$$r = 2gn^2 \quad (64)$$

The above relations only lack the merit of correctness of application to make the whole subject very simple. They were first devised when stub switches were in universal use and although

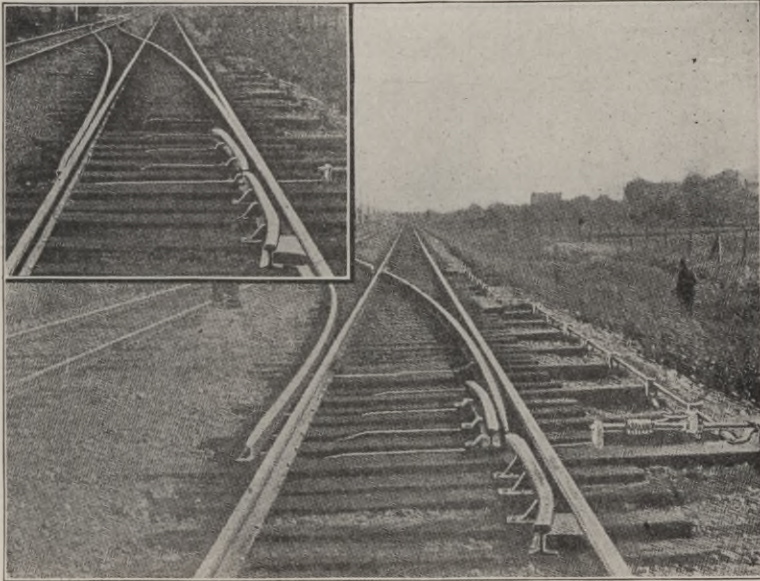

Fig. 117.

it is theoretically possible to make a stub switch conform to these lines, it is impracticable even there. But with point switches, which are in almost universal use, the switch rail makes an angle varying from  $0^{\circ} 52'$  to  $2^{\circ} 36'$  with the main rail. The frog rails are also made straight.

The effect of each of these changes, taken separately, is to shorten the lead. The combined effect is to shorten the lead from 15 to 25 per cent. In Fig. 121, DM represents the straight point rail and HF the straight frog rail, the two being connected by the



arc MH, tangent to both. The central angle of this arc is therefore  $(F - a)$ ,  $a$  being the angle (MDN) of the point rail. The chord MH makes an angle with the main rails which equals

$$\frac{1}{2} (F - a) + a = \frac{1}{2} (F + a)$$

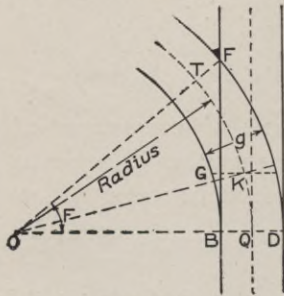

Fig. 118.

Call  $FH = f$  and  $MN = k$ . Then  $HM \sin \frac{1}{2} (F + a) = g - f \sin F - k$ . But  $HM = (r + \frac{1}{2} g) 2 \sin \frac{1}{2} (F - a)$ . Substituting this value of  $HM$  in the previous equation and solving for  $(r + \frac{1}{2} g)$  we have

$$(r + \frac{1}{2} g) = \frac{g - f \sin F - k}{2 \sin \frac{1}{2} (F + a) \sin \frac{1}{2} (F - a)}$$

$$= \frac{g - f \sin F - k}{\cos a - \cos F} \quad (65)$$

$$ST = 2r \sin \frac{1}{2} (F - a) \quad (66)$$

The lead  $BF = L = HM \cos \frac{1}{2}$

$(F + a) + f \cos F + DN$

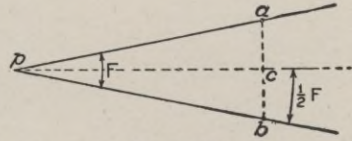

Fig. 119.

$$= (g - f \sin F - k) \cot \frac{1}{2} (F + a) + f \cos F + DN \quad (67)$$

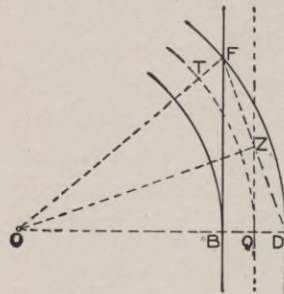

Fig. 120.

If  $(r + \frac{1}{2} g)$  has already been computed numerically from equation 65, it will be more simple to compute  $L$  as follows:

$$L = 2(r + \frac{1}{2} g) \sin \frac{1}{2} (F - a) \cos \frac{1}{2} (F + a) + f \cos F + DN$$

$$= (r + \frac{1}{2} g) (\sin F - \sin a) + f \cos F + DN \quad (68)$$





**INFIERNILLO BRIDGE ON THE OROYA RAILWAY, PERU**

Spanning a deep gorge in the Andes Mountains

*Photo by Underwood & Underwood, New York*

If the lead is computed for a turnout from a straight track using a No. 9 frog, a straight point rail and frog rail of the dimensions given in the middle section of Table III\*, it will be found that the lead becomes 72.61 instead of 84.75, the corresponding dimension assuming that the lead rails were circular throughout. Table III\* was computed on the basis of the above equations and the point switch dimensions which are in general use. The two references to section numbers in the table are to sections in Webb's "Railroad Construction," from which the tables were taken.

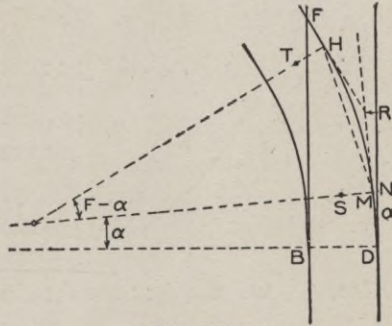

Fig. 121.

**121. Turnout from the Outer Side of a Curved Track.** When it is attempted to compute the dimensions of a turnout, from a curved track on the basis of using straight point rails and straight frog rails, it not only renders the demonstration exceedingly complicated, but it would involve assumptions regarding the mechanical construction which probably would not be followed in practice. Therefore the following demonstration is given with the purpose of showing the effect on the

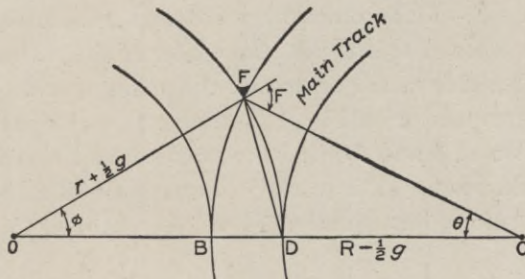

Fig. 122.

switch dimensions of curving the main track, the switch rails being circular throughout, and then drawing a reasonable inference as to the dimensions which should be followed for point switches from a curved main track. In the triangle FCD, in Fig. 122, we have

\*See Webb's "Trigonometric Tables," published by American School of Correspondence, Chicago, Ill. Price, 50c.

$$(FC+CD):(FC-CD)::\tan\frac{1}{2}(FDC+DFC):\tan\frac{1}{2}(FDC-DFC);$$

$$\text{but } \frac{1}{2}(FDC+DFC) = 90^\circ - \frac{1}{2}\theta, \text{ and } \frac{1}{2}(FDC-DFC) = \frac{1}{2}F;$$

$$\text{also } FC+CD=2R \text{ and } FC-CD=g;$$

$$\begin{aligned} \therefore 2R : g &:: \cot \frac{1}{2}\theta : \tan \frac{1}{2}F \\ &:: \cot \frac{1}{2}F : \tan \frac{1}{2}\theta \\ \therefore \tan \frac{1}{2}\theta &= \frac{gn}{R} \end{aligned} \quad (69)$$

$$\text{Also, } OF : FC :: \sin \theta : \sin \phi; \quad \text{but } \phi = (F - \theta)$$

$$\text{then } r + \frac{1}{2}g = \left(R + \frac{1}{2}g\right) \frac{\sin \theta}{\sin (F - \theta)} \quad (70)$$

$$\text{The lead, } BF = L = 2 \left(R + \frac{1}{2}g\right) \sin \frac{1}{2}\theta \quad (71)$$

A study of the three equations above will show that as the curvature of the main track increases and  $R$  grows less,  $\tan \theta$  increases and  $\theta$  increases. Then  $(F - \theta)$  decreases and  $r$  increases. When  $\theta = F$ , as it readily may,  $(F - \theta) = 0$  and  $r$  becomes infinity, that is, the switch rails become straight. If  $\theta$  becomes greater than  $F$ ,  $\sin (F - \theta)$  becomes negative and  $r$  becomes negative. The interpretation of this is that the center of the switch track will be on the same side as the center of the main track. The figure will then correspond with Fig. 123 except that the positions of  $O$  and  $C$  and also of  $\phi$  and  $\theta$  will be transposed and also that "main track" should read "side track." Equations 73 and 75 will be the same as before, but equation 74 will be changed to

$$\left(r - \frac{1}{2}g\right) = \left(R + \frac{1}{2}g\right) \frac{\sin \theta}{\sin (\theta - F)} \quad (72)$$

If we call  $d$  the degree of curve corresponding to the radius  $r$ ,  $D$  the degree of curve corresponding to the radius  $R$ , and  $d'$  the degree of curve of a turnout from a straight track for the same frog angle  $F$ , it will be found that  $d = d' - D$  very nearly. It

will also be found that the "lead" as computed above and as computed for a straight track will agree to within a few inches and frequently to within a fraction of an inch.

*Example.* Compute from the above equations the values of  $L$  and  $r$  (and then of  $d$ ) for the cases when the main track has a  $4^\circ$  degree curve and when it has a  $10^\circ$  curve; solve them for number 6, 9 and 12 frogs. This makes six cases. Compare them with values computed by the approximate rule.

In all these cases it may be shown that the discrepancies are very small. If such calculations are made for very sharp curves and for very large frog angles (which must be considered as bad practice), the discrepancies would be considerable, but since such turnouts (if ever made) should be operated at very slow speeds, the errors would have but little practical importance. Therefore we are justified in applying the approximate rule for turnouts from a curved track—use the same "lead" as for straight track; the degree of curvature for the switch rails to the *outside* of the main track will be the *difference* of the degree of curve for the main track and the tabular value for the degree of curve of the switch rails; for a turnout to the *inside* of a curved main track it may be similarly shown that the proper degree of curve for the switch rails is the *sum* of the degrees for the main track and the tabular value for the switch rails from a straight track.

Also, since it may be shown that the effect of using straight point rails and straight frog rails is to shorten the lead and to lessen the radius in approximately the same proportion, it may be assumed without material error that we may apply the same rule as above, and instead of taking the values of "lead" and "degree of curve" for the switch rails from the tabular form which uses circular switch rails throughout, we may take them from the revised form using straight switch rails and straight frog rails and apply the same rule.

**122. Turnout from the Inner Side of a Curved Track.** By the formation of precisely similar equations as were used in the previous section, we may derive the equation

$$\tan \frac{1}{2}\theta = \frac{gn}{R} \quad (73)$$

From the triangle OFC we may derive

OF : FC ::  $\sin \theta$  :  $\sin (F + \theta)$ , from which

$$\left(r + \frac{1}{2} g\right) = \left(R - \frac{1}{2} g\right) \frac{\sin \theta}{\sin (F + \theta)} \quad (74)$$

$$\text{The lead } BF = L = 2 \left(R - \frac{1}{2} g\right) \sin \frac{1}{2} \theta \quad (75)$$

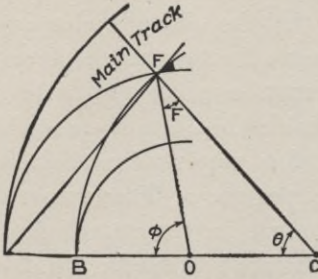

Fig. 123.

The details of the solution of the above equations should be worked out by the student; also a numerical demonstration of the fact, already referred to, that the degree of the turnout ( $d$ ) is very nearly the *sum* of the degree of the main track ( $D$ ) and the degree ( $d'$ ) of a turnout from a straight track when the frog angle is the same. It will be found that the discrepancy in these cases is somewhat larger than

in the previous case, although it is still so small that it may be neglected when the curvature of the main track is small. An inspection of the figure will show that when the curvature of the main track is sharp the curvature of the turnout is very excessive. Such conditions should be avoided if possible, that is, a turnout should not be located on the inside of a very sharply curved main track if it can be avoided.

**123. Numerical**

**Examples.**

1. Determine the lead and the radius of curvature for a turnout to the outside of a  $4^\circ 30'$  curve using a No. 8 frog and a point switch.

2. Determine the lead and the radius of a curvature for a turnout to the inside of a  $3^\circ 40'$  curve using a No. 7 frog and point switch.

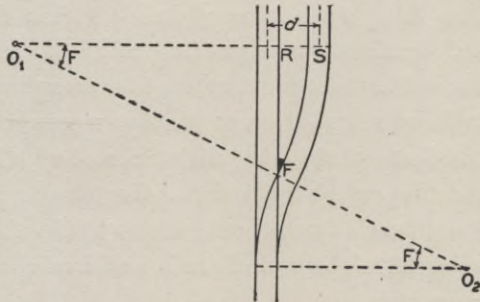

Fig. 124.

In each of the above examples use the switch point angles, length of switch point and length of straight frog rails as given in Table III\*.

**124. Connecting Curve from a Straight Track.** The "connecting curve" is that part of the siding between the frog and the point where the siding becomes parallel with the main track, or the distance FS in Fig. 124. Call  $d$  the distance between track centers. The angle  $FO_1R$  must equal the angle  $F$ . If we call  $r'$  the radius of the connecting curve, we may say

$$\left(r' - \frac{1}{2}g\right) = \frac{d - g}{\text{vers } F} \quad (76)$$

$$FR = \left(r' - \frac{1}{2}g\right) \sin F \quad (77)$$

The distance FR may be shortened somewhat by the method indicated in Fig. 129. Theoretical accuracy would apparently require that we should consider a short length of straight track at the point F. The effect may readily be shown to shorten the radius  $r'$  and to shorten the distance FR by an amount exactly equal to the length of the straight frog rail, but in actual track laying such a procedure might be considered a useless refinement. And therefore in this case as well as in the succeeding similar cases, the effect of the straight frog rail will be ignored. It should likewise be noted that the figure has been drawn for simplicity as if the switch rails were circular. But since the point  $O_2$  has no connection with the demonstration, it is immaterial what is the form of the switch rails back of F. This same remark applies to the following similar demonstrations.

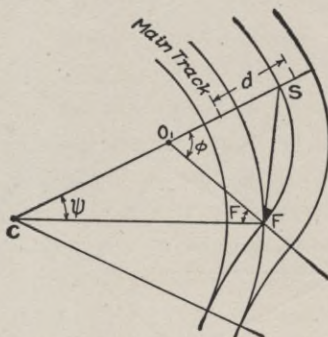

Fig. 125.

**125. Connecting Curve from a Curved Track to the Outside.** As in the previous case the only required quantities are the radius  $r$  of the connecting curve from F to S, Fig. 125, which

\*See Webb's "Trigonometric Tables," published by American School of Correspondence, Chicago, Ill. Price, 50c.



must be determined from  $r$  and the angle  $\phi$  ( $= F + \psi$ ). From the triangle CSF we may write

$$CS + CF : CS - CF :: \tan \frac{1}{2} (CFS + CSF) : \tan \frac{1}{2} (CFS - CSF)$$

but  $\frac{1}{2} (CFS + CSF) = 90^\circ - \frac{1}{2} \psi$ ; and since the triangle  $O_1SF$  is isosceles,  $\frac{1}{2} (CFS - CSF) = \frac{1}{2} F$ .

$$\begin{aligned} \therefore 2R + d : d - g &:: \cot \frac{1}{2} \psi : \tan \frac{1}{2} F \\ &:: \cot \frac{1}{2} F : \tan \frac{1}{2} \psi \quad \text{from which} \\ \tan \frac{1}{2} \Psi &= \frac{2n(d - g)}{2R + d} \quad (78) \end{aligned}$$

From the triangle  $CO_1F$  we may derive

$$\begin{aligned} r - \frac{1}{2} g : R + \frac{1}{2} g &:: \sin \Psi : \sin (F + \Psi) \\ \therefore r - \frac{1}{2} g &= \left( R + \frac{1}{2} g \right) \frac{\sin \Psi}{\sin (F + \Psi)} \quad (79) \end{aligned}$$

Also  $FS = 2 \left( r - \frac{1}{2} g \right) \sin \frac{1}{2} (F + \Psi) \quad (80)$

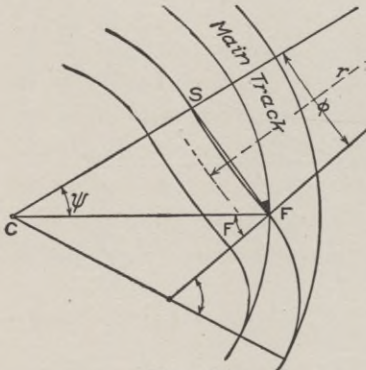

Fig. 126.

**126. Connecting Curve from a Curved Track to the Inside.**

There are three solutions according as  $F$  is greater than, equal to, or less than  $\Psi$ . In the first case, we may readily deduce, as in the previous section, from the triangle CFS (see Fig. 126) that

$$\begin{aligned} (2R - d) : (d - g) &:: \cot \frac{1}{2} \Psi \\ &: \tan \frac{1}{2} F \end{aligned}$$

and finally that

$$\tan \frac{1}{2} \Psi = \frac{2n(d - g)}{2R - d} \quad (81)$$

And as before, in equations 78 and 79, we may derive

$$\left(r - \frac{1}{2} g\right) = \left(R - \frac{1}{2} g\right) \frac{\sin \psi}{\sin (F - \psi)} \quad (82)$$

and 
$$FS = 2 \left(r - \frac{1}{2} g\right) \sin \frac{1}{2} (F - \psi) \quad (83)$$

When  $\psi = F$ , equation 80 will become

$$\tan \frac{1}{2} F = \frac{1}{2n} = \frac{2n(d-g)}{2R-d} \text{ from which we may derive}$$

$$2R - d = 4n^2 (d - g) \quad (84)$$

This equation gives the value of  $R$  which makes this condition possible. If we make  $F = \Psi$  in equations 81 and 82, we find in the first case that  $r$  is infinite, which means that the track is straight, and in the second case that  $FS = \text{infinity times zero}$ , which is "indeterminate." But from the figure itself we may readily see that

$$FS = \left(R - \frac{1}{2} g\right) \sin \Psi \quad (85)$$

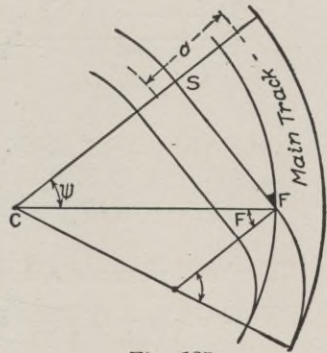

Fig. 127.

When  $F < \Psi$  we may derive the value of  $\tan \frac{1}{2} \Psi$  to be the

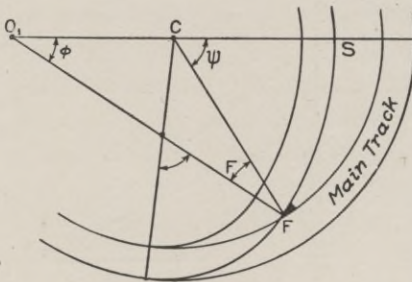

Fig. 128.

the same algebraically as in equation 81, although the figure is so different. By the same method as before we may derive for the value of  $r$  the equation.

$$r + \frac{1}{2} g = \left(R - \frac{1}{2} g\right) \frac{\sin \Psi}{\sin (\Psi - F)} \quad (86)$$

Also 
$$FS = 2 \left(r + \frac{1}{2} g\right) \sin \frac{1}{2} (\Psi - F) \quad (87)$$

**127. Crossover Between Two Parallel Straight Tracks.** As in the previous cases, although the figures are drawn for simplicity with switch rails as simple curves, the demonstrations only

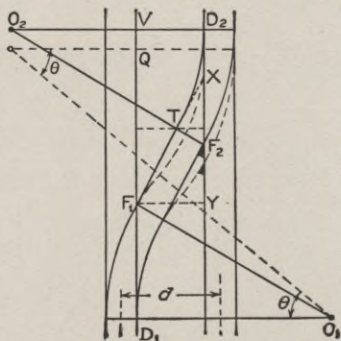

Fig. 129.

involve the frog angles and the nature of the track beyond the frog. The better method is that shown by the full lines, when the track is straight between the frogs. But this consumes so much of the main track (many times what is indicated in the distorted figure) that a reversed curve (as is indicated by the dotted curves) may be used. The length of the straight crossover track is  $F_1T$ .

$$F_1T \sin F_1 + g \cos F_1 = d - g$$

$$F_1T = \frac{d - g}{\sin F_1} - g \cot F_1 \quad (88)$$

The total distance along the track is

$$DV = D_1F_1 + YF_2 + F_2D_2 = D_1F_1 + XY - YF_2 + F_2D_2$$

but  $XY = (d - g) \cot F_1$  and  $XF_2 = g \div \sin F_2$

$$\therefore DV = D_1F_1 + (d - g) \cot F_1 -$$

$$\frac{g}{\sin F_2} + D_2F_2 \quad (89)$$

If a reversed curve with equal frogs is used, we will have the construction as is indicated by the dotted lines, and we have

$$\text{vers } \theta = \frac{d}{2r} \quad (90)$$

also

$$DQ = 2r \sin \theta \quad (91)$$

If it should for any reason be necessary to use frogs of different sizes, it may be done, but the point of reversed curve, instead

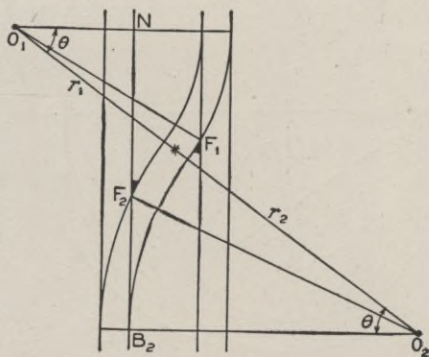

Fig. 130.

of being in the exact center, will be as is indicated in Fig. 130. In this case we will have

$$r_2 \text{ vers } \theta + r_1 \text{ vers } \theta = d$$

$$\therefore \text{vers } \theta = \frac{d}{r_1 + r_2} \quad (92)$$

The distance along the track will depend, as before, on the length of the "lead" for each switch. If it were circular, as indicated in the figure, we would have

$$B_2N = (r_1 + r_2) \sin \theta \quad (93)$$

but the true lead for point switches would be less than this by the difference between the true L and  $(r + \frac{1}{2}g) \sin F$ . Therefore, this

correction should be computed and subtracted for each switch.

**128. Crossover Between Two Parallel Curved Tracks.** In the previous case there is no practical limitation as to frog numbers, but in this case there are limitations on what frogs are per-

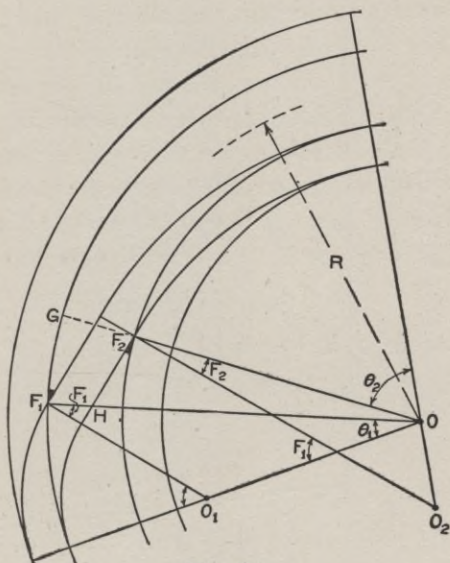

Fig. 131.

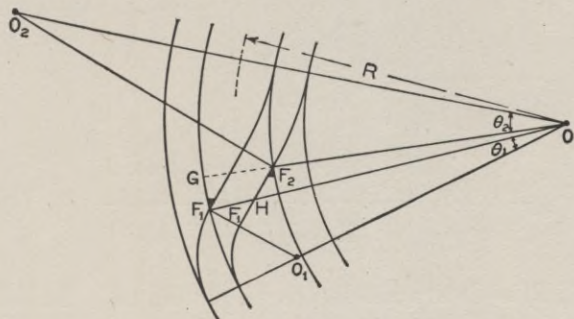

Fig. 132.

missible. If the connecting track is straight, there are still three cases depending on the value of  $F_2$ , as in section 121. Two of these cases are illustrated in Figs. 131 and 132. The following

demonstrations apply to both figures. If one frog ( $F_1$ ) is chosen, then  $F_2$  becomes determined as a function of  $F_1$ . If  $F_1$  is the angle for some even frog number,  $F_2$  will in general be an angle that does not correspond to any even frog number and therefore will need to be made to order. If  $F_1$  is less than some limit, depending on the width ( $d$ ) between the parallel tracks, it will be impossible to have a straight connecting track, and at some other limitation it will be impossible to have the reversed curve connecting track shown later. In Figs. 131 and 132 assume  $F_1$  as known. Then  $F_1H = g \sec F_1$ . In the triangle  $HOF_2$  we have

$$\sin HF_2O : \sin F_2HO :: HO : F_2O$$

but  $\sin F_2HO = \cos F_1$ ;  $HF_2O = 90^\circ + F_2$ ;  $\sin HF_2O = \cos F_2$ ;

$$HO = R + \frac{1}{2}d - \frac{1}{2}g - g \sec F_1; F_2O = R - \frac{1}{2}d + \frac{1}{2}g$$

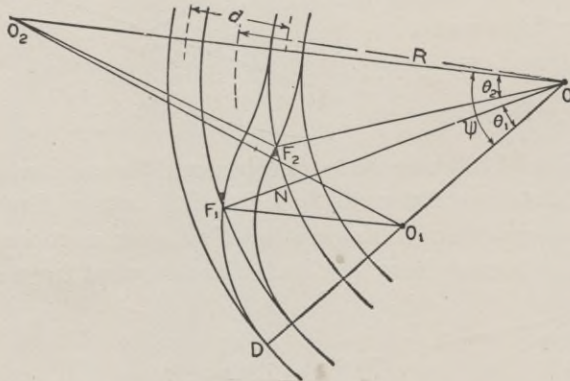

Fig. 133.

$$\therefore \cos F_2 = \cos F_1 \frac{R + \frac{1}{2}d - \frac{1}{2}g - g \sec F_1}{R - \frac{1}{2}d + \frac{1}{2}g} \quad (94)$$

Knowing  $F_2$ ,  $\theta_2$  is determinable from equation 69. To determine the relative position of the frogs  $F_1$  and  $F_2$ ,

$$HOF_2 = 180^\circ - (90^\circ - F_1) - (90^\circ + F_2) = F_1 - F_2; \text{ then}$$

$$GF_1 = 2 \left( R + \frac{1}{2}d - \frac{1}{2}g \right) \sin \frac{1}{2}(F_1 - F_2) \quad (95)$$

If the connecting curve is made a reversed curve, as is shown in Fig. 133, the frogs  $F_1$  and  $F_2$  may be chosen at pleasure (within rather close limitations, however), and this will usually permit the adoption of regular standard sizes and will not necessitate the making to order of special sizes. We may then consider that  $F_1$  and  $F_2$  are known and that they are equal or unequal as desired. Employing formula 29 in Table XXX,\* we may write:

$$\text{vers } \Psi = \frac{2(S - OO_2)(S - OO_1)}{(OO_2)(OO_1)}$$

in which 
$$S = \frac{1}{2}(OO_1 + OO_2 + O_1 O_2)$$

but 
$$OO_1 = R + \frac{1}{2}d - r_1$$

$$OO_2 = R - \frac{1}{2}d + r_2$$

$$O_1 O_2 = r_1 + r_2$$

$$\therefore S = \frac{1}{2}(2R + 2r_2) = R + r_2$$

$$S - OO_2 = R + r_2 - R + \frac{1}{2}d - r_2 = \frac{1}{2}d;$$

$$S - OO_1 = R + r_2 - R - \frac{1}{2}d + r_1 = r_1 + r_2 - \frac{1}{2}d;$$

$$\therefore \text{vers } \Psi = \frac{d(r_1 + r_2 - \frac{1}{2}d)}{(R - \frac{1}{2}d + r_2)(R + \frac{1}{2}d - r_1)} \quad (96)$$

$$\sin OO_2 O_1 = \sin \Psi \frac{OO_1}{O_1 O_2} = \sin \frac{R + \frac{1}{2}d - r_1}{r_1 + r_2} \quad (97)$$

$$O_2 O_1 D = \Psi + O_1 O_2 O \quad (98)$$

$$NF_2 = 2(R - \frac{1}{2}d + \frac{1}{2}g) \sin \frac{1}{2}(\Psi - \theta_1 - \theta_2) \quad (99)$$

The chief advantages of the above method are that it not only permits the use of standard size frogs, but also uses up less of the main track between the extreme switch points.

\* Found in Webb's "Railroad Construction".

**129. Problems in Switch Computation.** 1. A siding runs off from a straight main track, using a No. 8.5 frog. The distance between track centers is 13 feet. What is the radius of the connecting curve and its length?

2. A siding using a No. 9 frog runs off from the outside of a  $4^\circ 30'$  curve. What is the radius and length of the connecting curve? In all of these problems, consider the distance between track centers to be 13 feet.

3. Using the same frog, a siding is to run to the inside of the same track. What will be the radius and length of the connecting curve? Until  $\Psi$  is computed, it is impossible to say which of the three possible cases will be used, but the solution of equation 80 immediately decides that point, which will show that  $\Psi$  is slightly greater than  $F$ , but that the difference is so little that the resulting value  $r$  is very great.  $\frac{1}{2}(\Psi - F)$  is such a small angle that Table VI\* must be used to determine its sine.

4. If a crossover is to be run between two straight parallel main tracks 13 feet between centers, using No. 8 frogs, how much will be saved in distance measured along the main track by using a reversed curve rather than a straight track? Since the *difference* in distance is called for, we may ignore in this solution the absolute length of the switch rails and consider that they would be the same in either case.

5. Required the dimensions for a cross-over between two main tracks which are on a  $4^\circ 30'$  curve; the distance between track centers thirteen feet, the frog for the outer main track ( $F_1$  in Fig. 132) is No. 9;  $F_2$  is No. 7; the connecting curve is to be a reversed curve. When the radius of a double main track is given, it means the radius of the center line between the two tracks. We must, therefore (as indicated in Fig. 133), add and subtract 6.5 to the radius of a  $4^\circ 30'$  curve (1273.6) to obtain the radii of the centers of the two main tracks. The figure and formulæ allow for this. Since point switches would unquestionably be used, we must determine  $r_1$  and  $r_2$  by the method outlined in §121;  $R_1$  the radius of the outer main track = 1280.1 (which means that  $D_1 = 4^\circ 29'$ ), while  $R_2$  the radius of the inner track = 1267.1 and  $D_2 = 4^\circ 31'$ . Then by the rule of §121,  $r_1 = \text{radius of } (d_1 + D_1)^\circ \text{ curve}$

\*See Webb's "Trigonometric Tables," published by American School of Correspondence, Chicago, Ill. Price, 50c.

= radius of ( $7^{\circ} 31' + 4^{\circ} 29'$ ) curve = 478.34;  $r_2$  = radius of  $(d_2 - D_2)^{\circ}$  curve = radius of  $(12^{\circ} 26' - 4^{\circ} 31')$  curve = 724.31.  $d_1$  and  $d_2$  are the degrees of curve given in the first section of Table III\* as being suitable for a No. 9 and a No. 7 frog on a straight track. Obtain  $\theta_1$  and  $\theta_2$  by substitution in equations 69 and 73. It will be found that the point of reversed curve comes but a fraction of an inch from the frog point  $F_2$ . If the computations had apparently indicated that the point of reversed curve would come beyond either frog point (or between either frog and its switch), it would have shown the impracticability of the use of a No. 7 and a No. 9 frog under these particular conditions. It shows that in this case the limit was practically reached.

6. Solve the same problem using a No. 9 frog in both cases. In this case it will be found that the total length of main track between the extreme switch points will be somewhat increased, but that the point of reversed curve will be nearly midway between the two tracks, as is preferable. A comparison of the two solutions will then show how close are the limitations in the choice of frogs to be used.

**130. Practical Rules for Switch Laying.** The following directions are based on the methods previously given for allow-

ing for the effect of straight point rails and straight frog rails when used from a curved main track. When the position of the switch block is definitely determined, then there is no choice but to cut the main rails wherever the location calls for, but as the main track rail would be merely bent out to form the outer switch rail, there need be no rail cutting near the switch point, except that a rail-joint in the main rail should not come at or near the switch point. The frog has a length of from six to nine feet. A movement one way or the other of less than ten or twelve feet will bring one end of the frog at an existing joint and thus save one rail cutting.

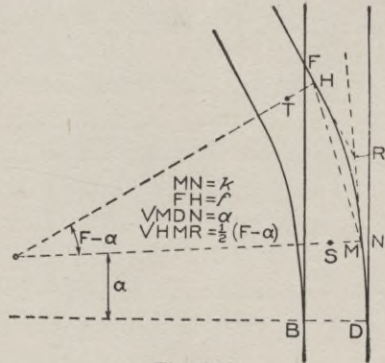

Fig. 134.

\*See Webb's "Trigonometric Tables," published by American School of Correspondence, Chicago, Ill. Price, 50c.



After having definitely determined just where the switch is to be located, mark on the rails the points B, D and F in Fig. 134. Measure off the length of the switch rails DN, and locate the point M at the distance  $k$  from N. If the frog must be placed during the brief period between the running times of trains it will be easier to joint up to the frog a piece of rail at one or both ends of just such a length that they may be quickly substituted for an equal length of rail taken out of the track. When the frog is thus in place, the point H becomes located. The curve between M and H is a curve of known radius. Substituting in equation 54 the value of *chord* and R, we obtain  $x$ , or  $db$  in Fig. 135, which is the ordinate for the middle point of the curve. Then  $a''a$  and  $c''c$  will be three-fourths of  $db$ . Theoretically this will give a parabolic curve, but the difference will not be appreciable. Having located and spiked down the rail HM, the opposite rail may be easily put in at the proper gauge.

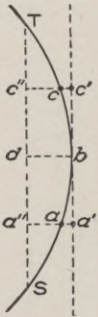

Fig. 135.

**Example.** *Locating a switch on a curved main track.* Given a main track having a  $4^{\circ} 30'$  curve, to locate a turnout to the outside using a No. 9 frog; gauge, 4 ft.  $8\frac{1}{2}$  in.;  $f=6.00'$ ;  $k=5\frac{3}{4}$  in.;  $DM=16.5$  ft.; and  $a=1^{\circ} 44' 11''$ . Then for a *straight* track  $r$  would = 616.27 ( $d=9^{\circ} 18' 27''$ ). For the curved track  $d$  should be nearly  $(9^{\circ} 18' - 4^{\circ} 30') = 4^{\circ} 48'$ , or  $r=1194.0$ .  $L$  for the straight track would be 72.61, but since the lead is

slightly increased (say about 0.1—see § 121) we may call the lead 72.7, although this difference would be absolutely imperceptible after the track was laid, so far as train running was concerned. After locating the switch and frog point as described above, the frog and the switch rails should be placed. The closure for the curved rail is given in Table III as 42.92 and curving the main track would make it slightly longer still, say 43.0.  $R=1194.0+2.35=1196.35$ . Applying equation 55, we have  $x=43.0^2 \div (8 \times 1196.35) = 0.193$ , the ordinate at the middle point. The ordinate at each quarter point is three-fourths of the ordinate at the center, or, in this case, 0.145.

**131. Slip Switches.** The complicated demands for switching in yards and terminals have been greatly assisted by the device

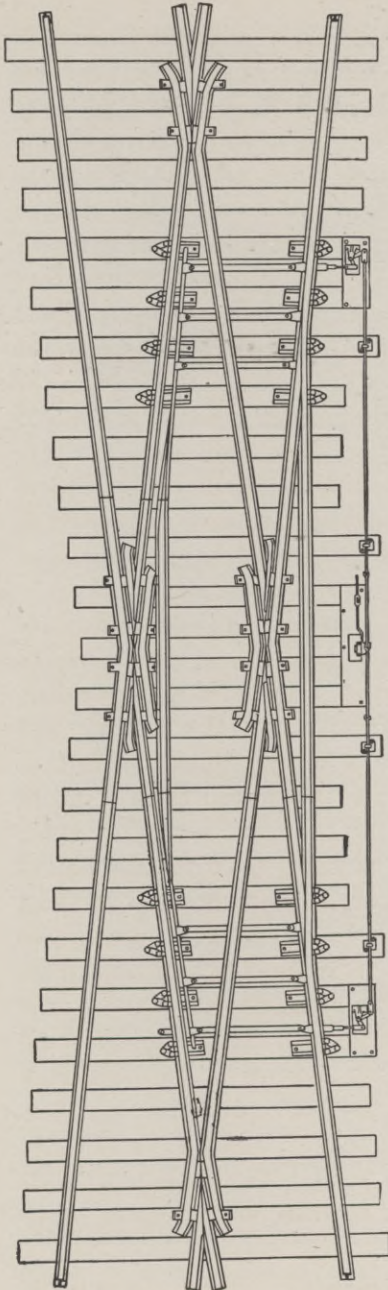

Fig. 136.

Slip Switches.

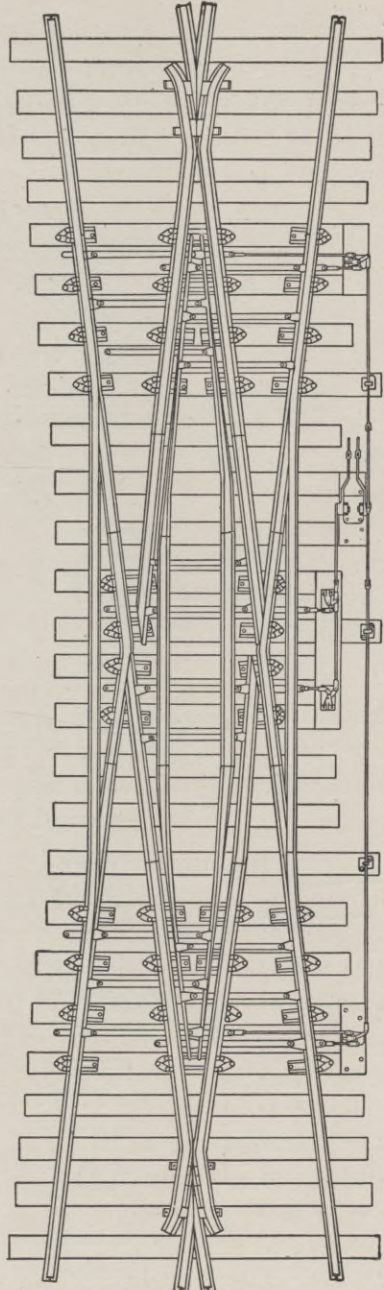

Fig. 137.

known as slip switches, illustrations of which are shown in Figs. 136 and 137. Fig. 136 shows a "single slip" in which the two middle frogs are fixed, although the system of movable frogs illus-

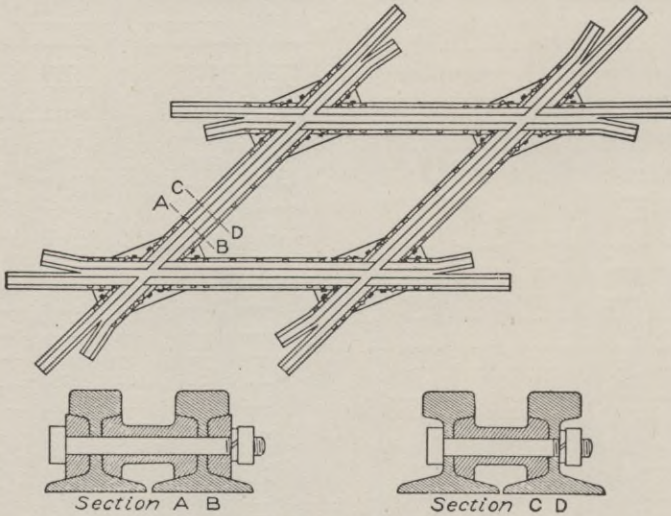

Fig. 138. Crossing.

trated in Fig. 137 is especially applicable. The double slip switch illustrated in Fig. 137 makes it possible for a train coming on either track to run directly on to either of the opposing lines. It should be noted that the mechanism is made interlocking so that the setting of a switch at one end will simultaneously set the switch at the other end as is required.

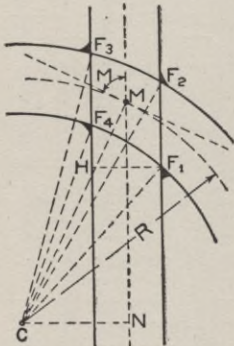

Fig. 139.

**132. Crossings.** When two railroads cross each other or even when it is desired to have one line cross another without having any switch connection, a crossing may be used. If the angle should be small (which is very undesirable) the method of movable frogs, shown by the crossing of the inner main rails of Fig. 137, may be used. But the lines

should be required to cross each other as nearly at right angles as possible and then a bolted or riveted set of frogs, with fillers between the rails, such as is illustrated in Fig.

138, may be used. In general these crossings will need to be made to order according to the angle between the two lines. Since such crossings are sometimes operated at very high speeds the construction must be especially strong and rigid. When both tracks are straight the frog angles are identical, or more strictly, two of them are "complements" of the other two. When one or both tracks are curved, all four frogs will be different and the computation of their exact value becomes a somewhat complicated geometrical problem. The mechanical construction need not be essentially different from that shown in Fig. 138.

**133. Crossing.** *One straight and one curved track.* In Fig. 139,  $R$  is known and also the angle  $M$ , made by the center lines at their point of intersection.

$$M = NCM \text{ and } NC = R \cos M$$

$$\text{then } \left(R - \frac{1}{2}g\right) \cos F_1 = NC + \frac{1}{2}g$$

$$\therefore \cos F_1 = \frac{R \cos M + \frac{1}{2}g}{R - \frac{1}{2}g}$$

Similarly it may be proved that

$$\cos F_2 = \frac{R \cos M + \frac{1}{2}g}{R + \frac{1}{2}g}$$

$$\cos F_3 = \frac{R \cos M - \frac{1}{2}g}{R + \frac{1}{2}g}$$

$$\cos F_4 = \frac{R \cos M - \frac{1}{2}g}{R - \frac{1}{2}g}$$

(100)

To find the relative positions on the tracks of the frogs, we may write

$$\left. \begin{aligned} F_3F_4 &= \left(R + \frac{1}{2}g\right) \sin F_3 - \left(R - \frac{1}{2}g\right) \sin F_4 \\ HF_4 &= \left(R - \frac{1}{2}g\right) (\sin F_4 - \sin F_1) \\ F_1F_2 &= \left(R + \frac{1}{2}g\right) \sin F_2 - \left(R - \frac{1}{2}g\right) \sin F_1 \end{aligned} \right\} (101)$$

It should be noted that  $F_3F_4$  will not be exactly equal to  $F_1F_2$ , although the difference will be very small.

**134. Crossing. Both tracks curved.** The angle of the tangents (or radii) at their point of intersection is a known quantity ( $M$ ) and also the two radii  $R_1$  and  $R_2$ . But since we must deal directly with the radii of the inner and outer rails of both curves, it will be easier to immediately

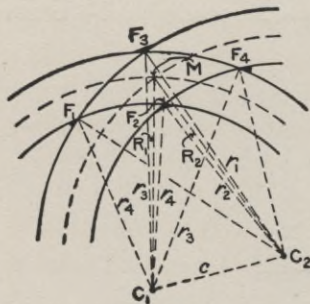

Fig. 140.

add (or subtract)  $\frac{1}{2}g$  to  $R_1$  or  $R_2$  and thus obtain  $r_1, r_2, r_3,$  and  $r_4,$  as indicated in Figure 140. Referring to the triangle  $F_1C_1C_2,$  and calling  $s_1 = \frac{1}{2}(c + r_1 + r_4),$

we may write:

$$\text{vers } F_1 = \frac{2(s_1 - r_1)(s_1 - r_4)}{r_1 r_4}$$

Similarly in the triangle  $F_2C_1C_2,$  let  $s_2 = \frac{1}{2}(c + r_2 + r_4)$

and in the triangle  $F_3C_1C_2,$  let  $s_3 = \frac{1}{2}(c + r_1 + r_3)$

and in the triangle  $F_4C_1C_2,$  let  $s_4 = \frac{1}{2}(c + r_2 + r_3)$

and then we may write

$$\text{vers } F_2 = \frac{2(s_2 - r_2)(s_2 - r_4)}{r_2 r_4}$$

$$\text{vers } F_3 = \frac{2(s_3 - r_1)(s_3 - r_3)}{r_1 r_3}$$

$$\text{vers } F_4 = \frac{2(s_4 - r_2)(s_4 - r_3)}{r_2 r_3}$$

(102)

To determine the length of track between the frogs we may write

$$\begin{aligned}\sin C_1 C_2 F_4 &= \sin F_4 \frac{r_3}{c} \\ \text{and } \sin C_1 C_2 F_2 &= \sin F_2 \frac{r_4}{c} \\ \therefore F_2 C_2 F_4 &= C_1 C_2 F_4 - C_1 C_2 F_2 \quad (103)\end{aligned}$$

Knowing the angle  $F_2 C_2 F_4$  we readily determine that the chord  $F_2 F_4 = 2r_2 \sin \frac{1}{2} (F_2 C_2 F_4)$ . In a precisely similar manner the chords  $F_1 F_2$ ,  $F_1 F_3$ , and  $F_3 F_4$  may be computed. As a check, it should be found that all these chords are nearly although not quite equal. Likewise the mean of all the four frog angles should be within a few seconds of the value of  $M$ .

**135. Examples.** 1. Determine the dimensions and the frog angles for the crossing of a straight track with a track of  $4^\circ$  curvature (as in Fig. 135) when the angle  $M = 72^\circ 18'$ .

2. A  $2^\circ$  curve crosses a  $4^\circ$  curve as in Fig. 140, the angle  $M$  being  $52^\circ 20'$ . Determine the frog angles and the chord lengths between the frogs.

### YARDS AND TERMINALS.

**136. Value of a Proper Design.** When a freight train arrives at a terminal yard, which is generally in a city of considerable size, with one or more other railroads or branches, the train load will in general be made up of some cars which will need to be shifted to some other road or division or to be shunted on to a siding where they may be unloaded. If the character of the train is mixed, partly coal and partly general merchandise or grain, the coal cars must be sent to their own tracks and the merchandise to theirs. A "division" point of a road is frequently the terminus of one or more branches as well as the point where freight trains are perhaps made up anew, especially if the ruling grade on adjacent divisions is so different that the train load which can be hauled by one engine is very different on the several divisions.

A little study of these facts, together with others which will readily suggest themselves in this connection, will show the vast amount of work which is necessary in sorting out the cars in a yard.

Often the road engine is cut off from the train as soon as it has brought it to its proper place in the yard, and the distributing is done entirely by switching engines. But the work in large yards is so great that several engines will be required for the work. The cost of running a switching engine per day may be figured as approximately \$25. If the design of a yard can be so altered that one engine can be dispensed with, or that three engines may be made to do the work which formerly required four, we would have in 313 working days per year an annual saving of \$7,825, which capitalized at 5%, gives \$156,500 which is sufficient to reconstruct almost any yard.

As will be developed later, such a saving is by no means an impossibility. The requirements for space for water stations, ash-pits, coaling stations, turntables, sand and oil houses, engine houses, etc., and their proper arrangement so as to avoid useless running of the engines, is another feature which shows the value of a systematic design for a yard. When a yard is being constructed at a new place, it may be designed on the basis of subsequent work, no matter how little of it is immediately constructed, but very many yards were laid out when the now recognized principles were unknown. Subsequent additions have only made a bad matter worse until it is seen that an entire re-construction is necessary to make the yard what it should be.

**137. Freight Yards. General Principles.** A yard built on an ideal plan is in general an impossibility. Topographical considerations usually influence the problem to such an extent that the only method is to study the location so that certain fundamental principles may be applied.

1. A yard is a classifying machine for receiving, sorting and despatching cars to their several destinations as rapidly as possible. Its efficiency is measured by the rapidity with which it accomplishes this and the economy of motive power which is required.

2. At a yard which is the terminal of a division the freight trains are pulled in to a "receiving track" so as to get them out of the way and off of the main track. The road engine is then run off to the engine yard where it is cleared of ashes, loaded with water, coal, sand, etc., and otherwise prepared for its next trip. Perhaps the caboose is run off to a "caboose track" the location of

which is made convenient. Then, if the train is a "through" freight, another engine and caboose may be attached and it may proceed unbroken unless a change in ruling grade requires a different train load.

3. There are certain tracks in a yard which may be considered the skeleton of the yard. On these tracks no trains should be allowed to stand except temporarily. Such tracks, shown in Fig. 141, in which each pair of rails is indicated by a single line, are called "ladder tracks," and from these the storage tracks are run in parallel lines. Other through tracks are indicated on the plan.

4. The storage tracks should usually be made double-ended or with a ladder track at each end. This usually facilitates the switching by permitting one or more cars to be drawn from either end without disturbing the cars at the other end of that track.

5. In recent years many yards have been made by creating an artificial hump at such a place that the grade from the ladder tracks on to the storage tracks is about 0.5 per cent. This creates a gravity force of 10 pounds per ton which is sufficient to cause a car to roll by gravity from the ladder track on to any storage track to which it may be directed. In this way a train of cars on the ladder track may be distrib-

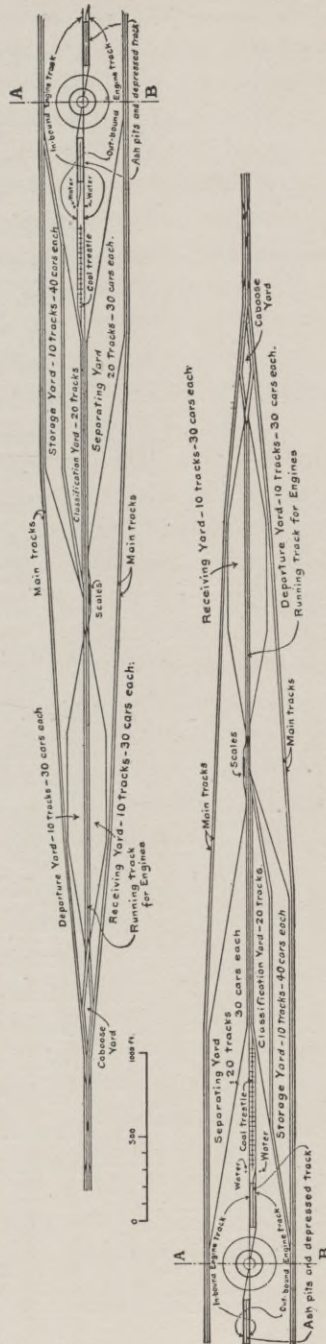

Fig. 141. Plan of Typical Freight Yard.



uted to the various storage tracks with great rapidity. Incidentally there is no danger of a car running out from the storage track

on to the ladder track. Symmetry and economy of space will usually require that the frogs and the switch dimensions of the switches running off from the ladder tracks shall be uniform. No. 7 frogs are very commonly used; frogs with a larger frog number make an easier riding track, but they require more space, and limit the space which may be used for storage. No. 6 and even No. 5 frogs are sometimes used on account of the economy of space which is thereby obtained, but it makes harder rolling and greater danger of derailment.

**138. Connection of Freight Yard with Main Tracks.** As a general principle the main tracks should be as clear as possible from the yard tracks so that passenger trains may run through freely at any time without even the danger of a collision with any freight cars or of interfering with the work of the freight yard. This practically means that there should be no crossing of the main tracks by any tracks used in yard operations and that the connection should be only where it is desired to run from the main tracks on to the receiving tracks and that here the switches should be thoroughly protected by signals. The ideal construction is to have (on double track roads) all opposing tracks cross over or under each other so that two trains will never approach the same point of track except when they are moving in the same direction and then the danger of a collision will be largely averted. The receiving



Fig. 142. Local Freight Yard.

tracks (or similar tracks) should be utilized as "departing tracks"

on which outgoing freight trains may wait for their signal to start without interfering with any passenger traffic on the main line tracks or any shifting work in the yard.

**139. Minor Freight Yards.** The name applies to the local collecting or distributing yards which are located in parts of a great city where the freight business is especially large. The cars are brought to these yards by means of long switches or by means of floats when the yard is located on a water front. The special feature of these yards is the fact that since they are always located on very valuable land, great ingenuity is required to utilize the limited space to the greatest advantage. This usually requires excessively sharp curvature, which may be limited by the fact that car couplers will not permit the car bodies to make a large angle with each other. The shortest permissible radius is 175 feet and even this is undesirable. Radii as short as 50 feet have been used in some yards, but in that case an extension coupling bar is placed between the cars. Yards for receiving or distributing freight should be provided with team tracks which are made stub-ended and which are preferably placed in pairs with a sufficient space for roadway between each pair.

Figures 141 and 142 are ideal plans which were submitted to the American Railway Engineering and Maintenance of Way Association at its meeting in March, 1902. As "ideal" plans, it is not supposed that they can be literally adopted, but a study of them will show their general conformity with the principles stated above, and also will be suggestive of plans adapted to the local conditions.

**140. Freight Yard Accessories.** *Track scales.* These are for weighing freight cars on the track. When, as is frequently the case, the scales are located on a much used track, an auxiliary pair of rails is laid about six inches from the scale rails and connected with them by a split rail switch at a suitable distance from each end of the scales. One auxiliary rail is supported on the side of the scale pit and the other on several posts which run through the scale table floor. It has been found practicable to weigh a whole train load even in motion by running it very slowly over the scale tracks and noting the scale reading for each car when it becomes central over the pit.

*Cranes.* The frequent transportation of individual loads weighing many tons requires the use of some sort of unloader, which may vary from the temporary "gin pole" to a traveling crane which strides one or more tracks and a roadway, and which may travel on rails parallel with the switch tracks and also has a "traveler" which runs perpendicular to the tracks. The double horizontal motion (as well as the vertical motion) permits the loading or unloading between any car and wagon placed within its range. While their use is somewhat limited, there are occasions when they are almost indispensable.

**141. Engine Yards.** The ideal position for the engine house with its accessories is in the center of the yard, as is shown in Fig.

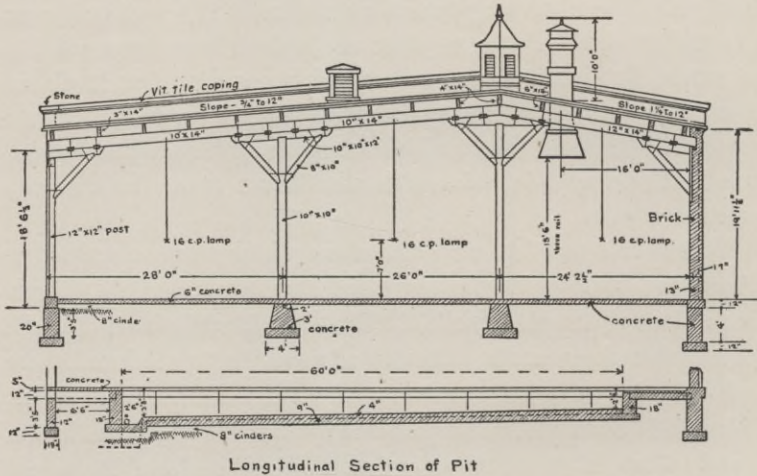

Fig. 143.

141. The accessories of an engine house are shown in the ideal plan of Fig. 143. The plan of the cinder pit, which is shown in detail, allows for a pit about four feet deep under two tracks on which the engines run, and into which the ashes can be directly dumped. These tracks are each side of a depressed track which is sunk to such a depth that the sides of a gondola car will be below the bottom of the ashpits under the engine tracks. The dumped ashes can therefore be very easily shoveled into the car in the depressed track.

Passenger terminals for large cities are structures which demand the services of an architect rather than an engineer. The engineering features are largely those of elevating or depressing the approaching tracks so as to avoid the grade crossing of city streets, and all such problems must be solved individually. Those who wish to study the subject further may find it treated very fully in "Buildings and Structures of American Railroads," by Walter G. Berg.

### SIGNALING.

The following description of signaling is not to be considered as a complete course on the subject as that would require more space than may here be devoted to it. The discussion has been condensed to such fundamental facts as every railroad engineer should know. The development of the science has been so rapid during late years that one must follow current engineering literature to keep abreast with the progress of the work. A student desiring a more thorough course in the groundwork of the subject is referred to "The Block System," by B. B. Adams (234 pages), as well as to similar but earlier works by W. H. Elliot and W. L. Derr.

**142. Systems.** When railroading was still in its infancy but traffic had so increased that rear-end collisions on double track became an imminent danger, two general plans were suggested and tried to guard against such accidents—(a) the time interval system and (b) the space interval system. Although some traces of the first system are still to be found in train order systems and in operating rules and time tables, it has been found inadequate for the operation of heavy traffic. When trains are run close together, even a short delay becomes a source of danger, which is only partially obviated by vigilant work by the rear flagman, and even this safeguard is only obtained at the expense of further delay in waiting for the flagman to return to the train after the cause of the delay is removed and the train is able to proceed. The space interval system has therefore become the basis of all modern systems.

Considered from another standpoint, the methods of handling trains may be divided into two general classes—(a) the telegraphic order system, in which men at different parts of the line receive

orders by telegraph regarding the movements of trains which will soon pass them and who communicate these orders to the trainmen either verbally or by signal, and (b) those systems under which the signals at any point are controlled by mechanism at adjacent points. The fundamental difference between the two systems is that in the first case a blunder by any one of several men may cause an accident; in the second case, blunders are, to a considerable extent, mechanically impossible, and when made are generally immediately apparent to one or more others, and may be corrected in time to prevent an accident.



Fig. 144.

The first system includes the method by which a large proportion of the trains of the country are operated—the “train order” system, which will not be here elaborated since “signals” are not a necessary feature of it. Under this method the train crew receive their orders, issued by the train dispatcher of the division, which are written out by the telegraph operator at the local office where received. The train is then run in accordance with such orders until it reaches the next train order office. The first system also includes the simple manual system, described in the next section. The various systems of controlling the signaling, culminating in the absolutely automatic system, will be successively described.

**143. Simple Manual System.** In this, as in all other block systems, the road is divided into sections or “blocks” whose lengths are varied somewhat to suit the method adopted and the natural conditions, and also are made roughly proportional to the traffic. For example, on the main line of the Pennsylvania Railroad between Philadelphia and Harrisburg the sections have an average length of a little over two miles, a few are four miles long, and some (especially where the suburban traffic is heaviest) are less than one mile long. On the other hand, on a road with less traffic (although sufficient to require the block system), the blocks might have a much greater length. “Absolute” blocking forbids the entrance of a train into

a block until the preceding train has passed out of it. This practically means that the trains must average considerably over one block apart, since train B (see Fig. 144) cannot enter the block (2—1) until train A has passed out of that block, and the fact is telegraphed back so that the signals at (2) may be set for train B to enter the block. Train C and the succeeding trains must virtually maintain the same interval even though they temporarily move up closer. At a freight train speed of 15 miles per hour, trains could be run through blocks five miles long at intervals of twenty minutes plus the time required for signaling between stations and for the trains to pass by the signal station. Under the simple manual system the rules of operation, although varied in detail, are essentially as follows for double-track work:

When train A has passed (1) the operator there telegraphs the fact back to (2), and then the operator at (2) knows that the block from (2) to (1) is clear and that he can admit train B to the block. If train B does not arrive at (2) for some time afterward, (2) should obtain definite word from (1) immediately before B is due that the block is clear, since it might have become obstructed by switching operations or otherwise. As soon as train B has passed (2) the fact is telegraphed back to (3), which informs (3) that the block (3—2) is clear. The method of communication is usually by the ordinary Morse alphabet, but since the facts to be communicated are very few and simple, a system of taps on electric bells, which can be more easily and quickly learned than the Morse alphabet, are sometimes used. During recent years even the telephone has been used for this purpose. Some of the mechanical details of this method will be given later. Each road employing such a system has a more or less elaborate set of rules governing the operation of the signals, whose object is to make the work as mechanical as possible, to guard against giving wrong signals and to locate the blame when an error is made.

It should be noted, however, that there is nothing to prevent a signalman from giving a "clear" signal, when he should show a "stop" signal, even when he has been instructed otherwise and has perhaps reported by telegraph that he has obeyed orders. In short he is not "controlled," and in case of an accident there is a

question of veracity between him and the engineman. The system has the merit of cheapness, since the signals may be of the cheapest form and the intercommunication may be done by the cheapest form of telegraphic circuit.

*Permissive Blocking.* There is a variation of the "absolute" system which is also applicable to some of the following systems and which facilitates traffic although at some sacrifice of safety. Under this system, a train is allowed to proceed into a block even though there is a train still there. But the train must be under "perfect control" (some rules limiting the speed to six miles per hour) so that it may be stopped very quickly, if necessary. By this means, the delay of a succeeding train, and perhaps of several following trains, is very greatly reduced. Of course such a practice requires extreme caution to avoid accidents, and there are very minute rules to be followed when such running is permitted at all.

When heavy passenger trains are run at a speed approaching 60 miles per hour, it becomes impracticable to make a "service" stop much within 1,500 feet. Although a stop *may* be made in a much shorter distance, it induces very severe strains in the rolling stock and hence should be avoided. But since it is frequently impossible, on account of curves or other obstructions, to see signals more than a few hundred feet away, an engineman dare not approach a "home" signal at very high speed for fear a stalled train may be immediately beyond it. Therefore a "*distant signal*," which forewarns the engineman of the indication of the "home" signal, is placed 800 to 2,500 feet from the home signal. The required distance, which for mechanical reasons is made as short as possible, except as noted below, depends on the grade and on how far from the signal it may be clearly seen.

When the distant signal is set for "clear," the engineman knows that he may proceed at least as far as the *second* home signal ahead; when it is set for "caution," he knows that he may proceed at least as far as the next home signal, but he must expect to be stopped there and he must have his train under such control that he can stop there if required. Sometimes the signal becomes cleared by the time he reaches the home signal and there is no actual delay beyond a slight reduction in speed, but the indication of the distant signal enables him in any case to approach the home

signal confidently, knowing beforehand that it will be "clear" if the distant signal was "clear." In any system where the signaling is "controlled," such a distant signal is locked so that it cannot indicate clear when the home signal indicates stop. Under the "automatic" systems the distant signal is usually placed on the same post as the home signal for the preceding block. In this case, when the distant signal indicates clear, the engineman knows that his road is clear for two full blocks, but he may have to slacken speed when he reaches the next block station.

**144. Controlled Manual System.** In the previous system the only connection between the signal stations is the telegraphic communication of information. The "controlled manual" system includes the following essential elements. The signals at each station are locked by electromagnets which are controlled electrically from the signal station ahead. When a train approaches (1), (1) must notify (2) of it. If the last previous train has passed (2) and there is no other impediment, (2) will unlock (1)'s lever electrically, so that it is possible for (1) to set a clear signal. After the train has passed (1), the signal at (1) is set for the "stop" position. It will then be impossible for him to set it clear again until permitted to by (2). Knowing that the train is coming, (2) inquires of (3) if the block (2—3) is clear and if so (3) will unlock (2)'s lever so that it can be set for clear. The above is the simplest and earliest form of such a system.

The chief advance over the simple manual system lies in the mutual control of the signal offices on each other. A signalman cannot set a signal clear except by the action of the next signalman ahead who thereby certifies that the block ahead is clear. The chances of error are thereby decreased. The electrical control is maintained over a "wire circuit," but the system is made much more under control by adopting features which are essentially those of the automatic system. The two rails of the track are carefully insulated from each other, and, near each signal station, the abutting rails are insulated at

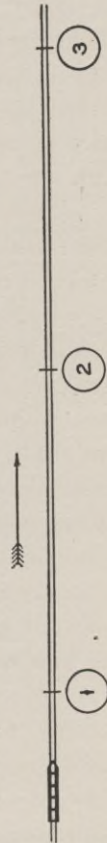

Fig. 145.



some joint by joining them with insulated joints such as are described in section 107.

At B, Fig. 146, a track battery sends a current through the rails which energizes the track relay at A, which operates the signal mechanism at A. The presence of even a single pair of wheels on the track between A and B, or even on the siding up to the "fouling point," will cause the current to be short-circuited and it will fail to energize the relay at A. By this means it is readily arranged that when the train passes A, A's signal will automatically fall to "stop" and will become locked there so that it cannot become unlocked until the train passes the insulated joints at B. When the train passes B, the current through the relay will then become strong enough to release the lock and then A can set his signal to "clear" if permitted to by B.

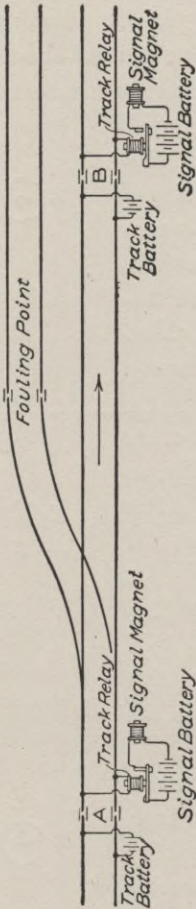

Fig. 146.

go to "stop" and the signal would stay locked until the track was cleared. A broken rail would have the same effect of locking the signal and would start an investigation to determine the trouble.

**145. Automatic Systems.** Some of the principal essentials of the automatic systems have already been described above. Some

of the differences are as follows. The mechanical work to be performed by the electric current in the controlled manual system is limited to unlocking certain mechanisms or unlocking the signals so that by gravity they will assume the "stop" position. The heavy work of moving the signals, which are usually of the "semaphore" type (described later) is performed by the signalmen. But automatic signals must be worked by a mechanism which always has sufficient power to move the signals. This practically means that the signals must have such a form and be so worked that but little force will be required to move them.

The earliest forms were targets mounted on a vertical axis which was swung around by clockwork. When set for "stop" a red target would show; when set for "clear" the red target would turn edgewise and a white target of different form which was previously edgewise (or perhaps no target at all) would then show. A lantern, with red lenses on two opposite faces and white (or green) lenses on the other two faces would be set on top of the axis. A weight moving up and down in a hollow iron post, would be periodically wound up to provide the power. Each time the signal is changed from "stop" to "clear" or from "clear" to "stop" the axis turns one-quarter turn. One objection to the method lies in the fact that since putting even a handcar or a track gauge on the rails will turn the signal to danger and taking it off will restore it to clear, the mechanism will be made to work so often that it will require rewinding with annoying frequency and then perhaps become run down and fail to work.

To guard against one source of danger, the mechanism is made to open the circuit and thus put the signal to "stop" just before it becomes run down, so as to avoid the possibility of the signal indicating clear when it should indicate danger. The clockwork system is still in successful use on some of the systems where it has been installed many years, but the more recent designs use an enclosed disk signal (described later). An important detail is the placing of the signal 200 feet in advance of the entrance of a block section. This enables the engineer to *see* the signals turn to danger as a result of his entering the block and he thus knows that there is a signal protecting him until he reaches the next signal.

If the signal fails to work, it shows that there is something wrong with the mechanism and he will take precautions accordingly.

Another advantage of the track circuit system lies in the fact that if a switch be opened anywhere in a block, the switch being provided with a circuit breaker, the circuit will be broken and the signal will automatically fall to danger. In short, almost any defect or impediment to a clear track will be indicated by the signal. And herein lies one troublesome feature: the circuit is so sensitive that any accidental short-circuiting (even though not due to any defect or obstruction of the track) will delay traffic. The opposite (and far more serious) error in operation—indicating “clear” when it should indicate “stop”—will only be caused by a defect in the mechanism, and the record in that respect is very good, the proportion of such errors to number of signal movements being exceedingly small.

**146. Mechanical Details.** The train order system does not necessitate signals of any kind, but on many roads which make no claim to a block signal system a signal of some sort will be displayed from the local train-order office. The signal may be a mere flag on a stick; an improvement is to hang it from a horizontal support, the lower edge being weighted, the whole being provided with a cord which is run back to the office, which permits the ready display or removal of the flag. Some western railroads have improved these by using some “home-made” signals operated similarly, but using a target made of thin wood or of sheet metal. From this it is but a short step to the standard “semaphore,” illustrated in Fig. 147 and elsewhere.

The semaphore consists essentially of a board about five feet long, eight inches wide at the outer end and six inches wide at the hinge end. The hinge is a somewhat elaborate casting with one or more “spectacles” as holders of colored glass lenses. Since the weight of the casting on the spectacle side is usually not sufficient to overbalance the weight of the semaphore board, a counterweight is so attached that if the rods or wires to the signal cabin should break, the signal will automatically assume the horizontal position, which is universally considered as the “stop” or “danger” signal. When the axis of the board passes through the hinge bolt, as is

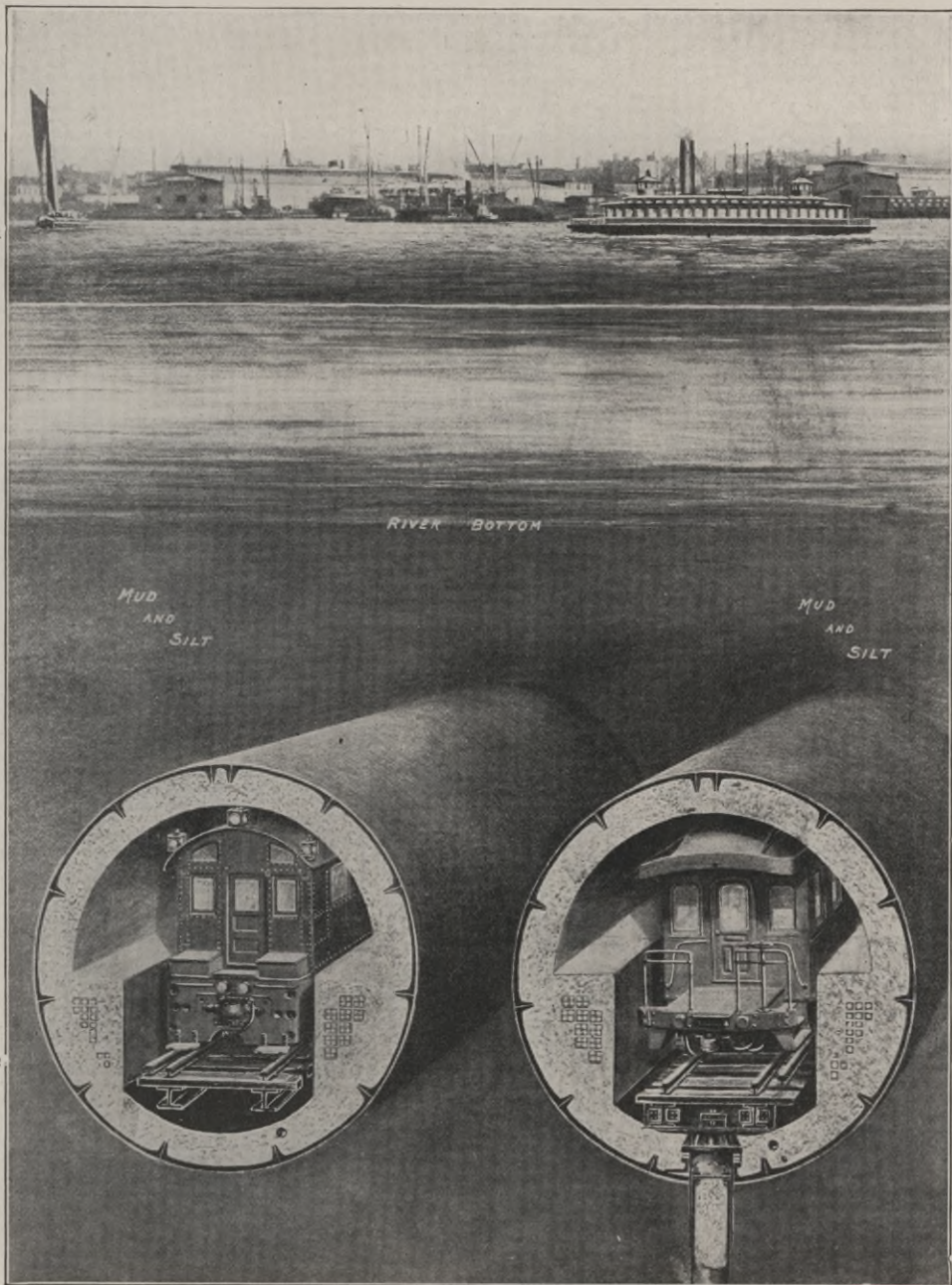

TWIN RAILWAY TUNNEL TUBES UNDER THE HUDSON RIVER AT NEW YORK  
Built for the Pennsylvania Railroad. Tubes of steel and concrete.



shown in Fig. 147, the "clear" position is given by inclining the board at an angle of  $45^\circ$ , as shown in position B.

Another form is to have the board eccentric to the hinge, so that it may be dropped to a vertical position and still show outside of the post. As a general principle of construction, the board should be clearly visible even in foggy weather, and therefore the board should not come down directly in front of the post, for in foggy weather it would not be clearly visible and an engineman might pass the signal thinking it was in front of the post, when it might have been broken off and should have indicated danger. Fig. 147 shows a wooden post; the latest high-grade practice now uses iron posts with suitable castings at top and bottom. One advantage of such posts is the placing of the rods inside of the post where they are less subject to interference from snow and sleet and from malicious mischief.

The boards are always set so that they point to the right from the track which they govern, or in other words a signal which points to the left of its supporting pole, as seen by an approaching train, governs trains moving in the opposite direction. Sometimes the boards are painted red on the governing side and white on the other side, but whatever the variation in practice the indication is inde-

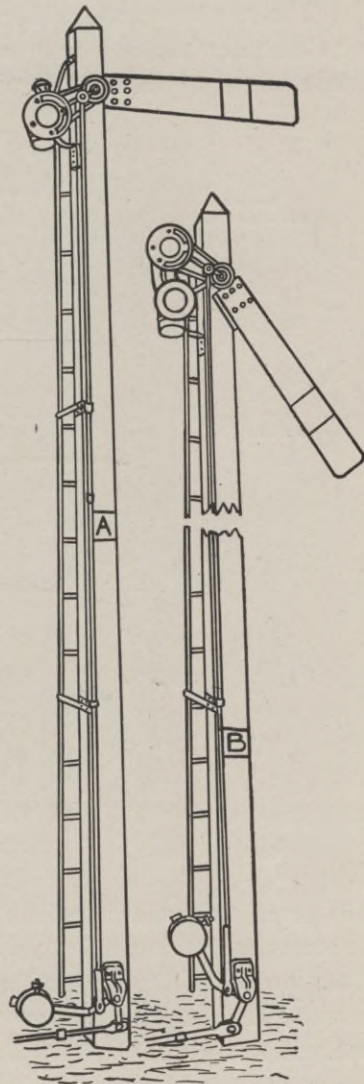

Fig. 147. Semaphore.

pendent of the color, and on some roads the color is "neutral," so as to emphasize the fact that the engineman must be governed by the *form* and *position* of the board rather than by the color.

The only essential variation of form of the blade lies in making the ends of all home signals square and of all distant signals notched or of a "fishtail" form. One other form used for the dis-

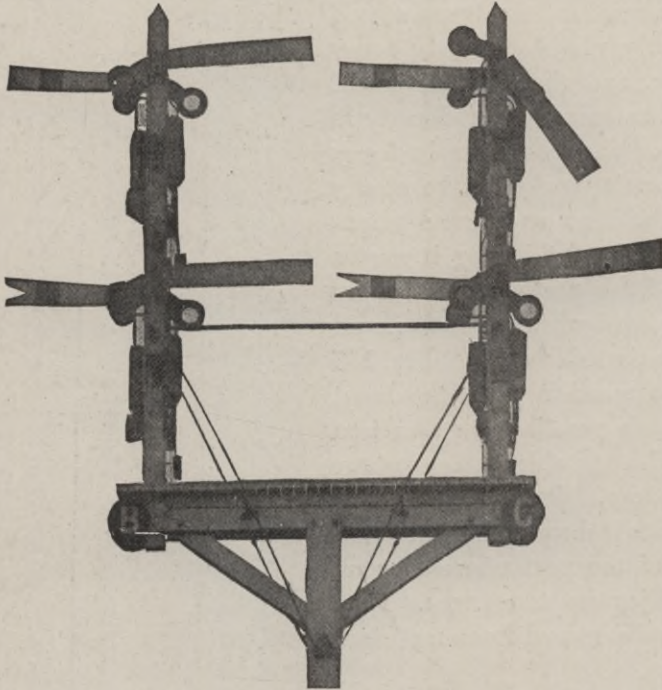

Fig. 148.

tant signal is to make it pointed. When there are but two tracks the semaphores are usually placed on separate posts on each side of the roadbed. Even when there are four tracks, the signals for the two tracks on each side may be placed on one main pole which has a cross-arm and two uprights, each carrying one or more semaphores, as shown in Fig. 148. But when there are more than four tracks (as in yards), and frequently on four-track roads, the signals are carried on a "bridge" such as is illustrated in Fig. 149. In such a case the signals for each track are placed directly over the track.

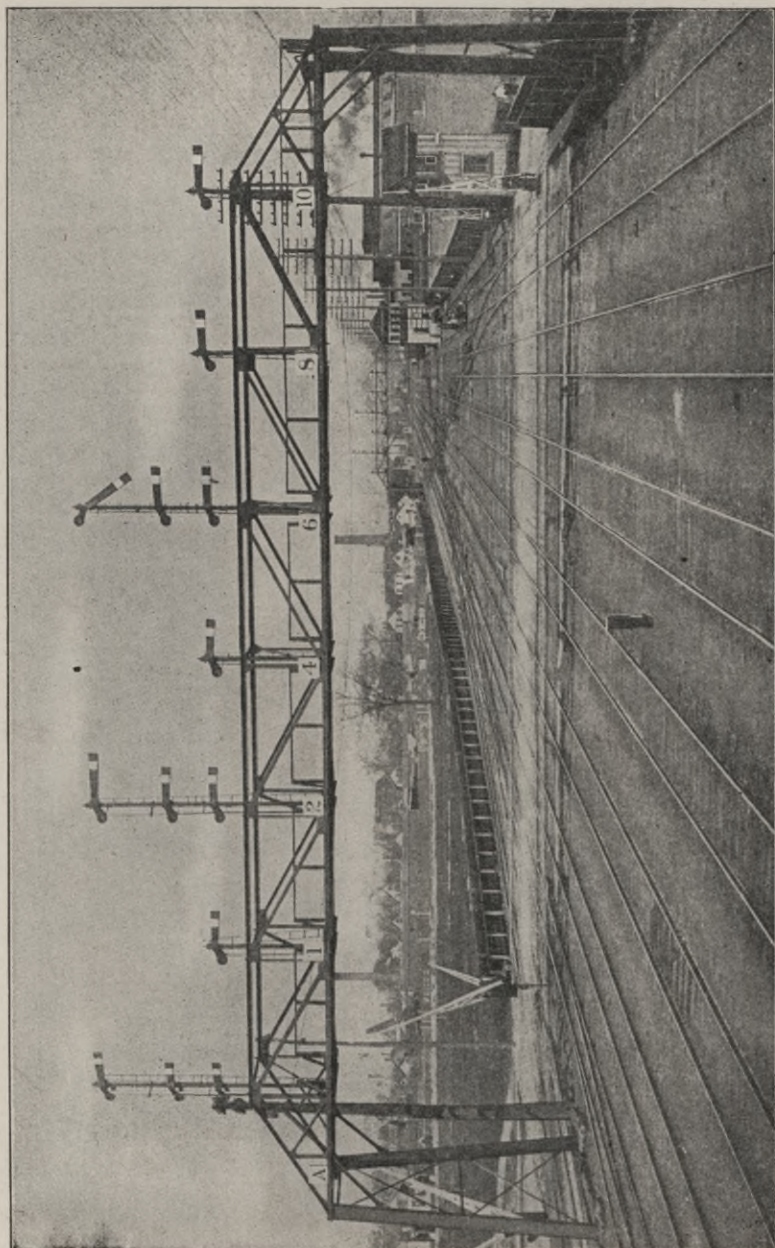

Fig. 149. Semaphore Bridge.



When more than one square-ended signal is over a track, the upper one refers to the through track and the lower ones to the switches which will be immediately encountered. Note in Fig. 149 that the signal bridge in the background has boards on the *left* side of the posts and that they are evidently *white*. This shows that the bridge governs movements *toward* the observer, while the signals on the bridge in the foreground evidently govern train movements in the direction the observer is looking. The mechanism of all such signals is necessarily somewhat exposed, and is liable to be actually blocked when covered with snow and sleet. A considerable amount of power must therefore be available to operate such signals.

Another form in extensive use is the enclosed signal.

*Enclosed signals.* There are two great arguments for and against the use of such signals. On the one hand, the mechanism is entirely enclosed and protected from the weather and is therefore uninfluenced by wind, snow or sleet. Also the mechanism can be made so very light and delicate that it requires only a small percentage of the power required to operate semaphores, and therefore they can be operated by an electric current of very low voltage. On the other hand, the signal is not one of *form* and *position* but of *color* only. It is argued that it cannot be as clearly seen in stormy weather and on that account is less safe. While it is unquestionably true that the signal indication is less visible in bad weather than a semaphore, yet the net advantages of the system are such that the system is very largely used.

The external appearance of the top of the signal (the post being omitted in the illustration) is as shown in Fig. 150. "Clear" is indicated by the disk opening showing white. To indicate danger a very light screen, made by stretching red silk over a light hoop, is swung over the opening. At night the lantern on the rear side shines through the opening, showing white or red according to the position of the screen. The detail of the mechanism, shown in Fig. 151, explains its operation. When the magnet is energized the disk is drawn up out of view and the signal shows white. If the current fails for any reason, the disk falls by gravity and comes into view. The power required is so small that the magnet not only controls the signal but also develops the power to move it.

**147. Wires and Pipes.** Wires are used for the transmission of electric current and pipes are used to transmit pneumatic pressure—as discussed later. But the above heading refers to wires

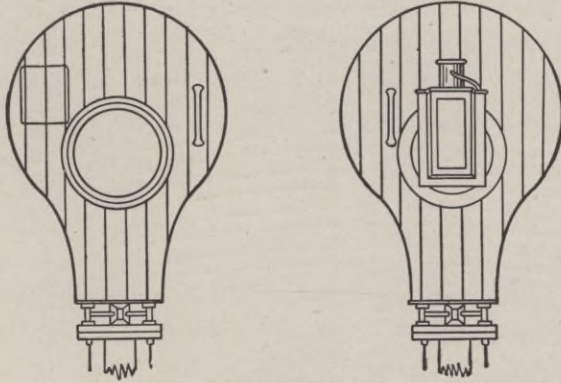

Fig. 150. Enclosed Signal.

and pipes as used to mechanically transmit motion from the signal cabin to the signal. When the parts may be made to work by tension, No. 9 wires may be used. When it is required to turn a right angle a grooved wheel is used and a short length of chain

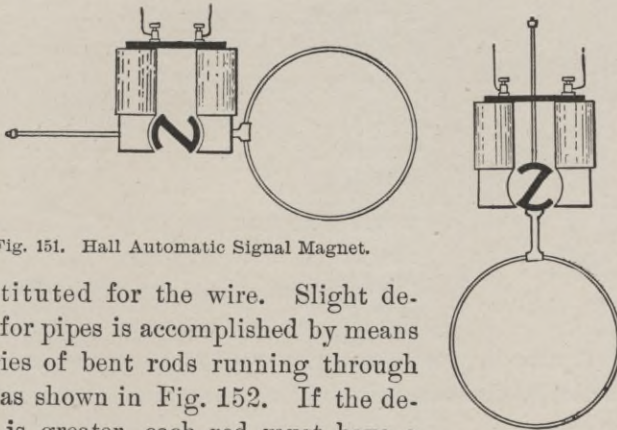

Fig. 151. Hall Automatic Signal Magnet.

is substituted for the wire. Slight deflection for pipes is accomplished by means of a series of bent rods running through guides, as shown in Fig. 152. If the deflection is greater, each rod must have a "bell crank." It is possible to work a signal with one wire, depending on gravity for the reverse motion, but good practice requires a wire for each motion. Signals are

sometimes operated mechanically at a distance of 2,000 feet from the cabin. For such, wires are practically a necessity, but when the signals are nearer, pipes which may exert a push as well as a pull are used.

*Compensators.* The coefficient of expansion of iron is so high that the change of length in a wire or pipe several hundred

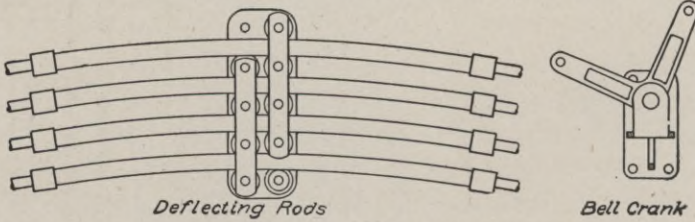

Fig. 152.

feet long is so great that the signaling mechanism is thrown out of adjustment unless there is some automatic device to counteract it. The change of length of 1,500 feet of wire due to a fall of temperature from  $100^{\circ}$  F. to  $20^{\circ}$  is  $1500 \times 80 \times .0000065 = 0.78$  foot = 9.36 inches. A much less change than this would

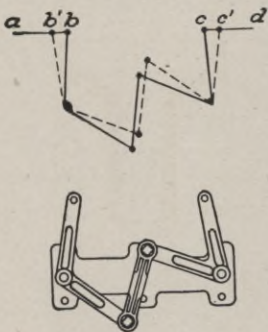

Fig. 153.

require adjustment. The geometrical principle of the automatic compensators is shown in the upper part of Fig. 153 and the practical construction is shown below it. By reference to the figure it may be seen that if the pipe  $ab$  contracts so that  $b$  moves to  $b'$ , the point  $c$  would be moved to  $c'$ , where  $bb' = cc'$ . But if  $cd = ab$ ,  $dc$  would also contract to  $dc'$ . Therefore if the compensator is placed midway between the cabin and the signal, the cabin end of the pipe being fixed, a point at the signal

end would retain its position regardless of any temperature change.

Practically these arcs should not be required to work through too great an angle. It has been found that 500 feet is a desirable limit. Therefore if a signal was 1,000 feet away from the cabin, two compensators should be used, each placed 250 feet from the ends. Then the position of the ends and the middle point would

be unchanged by temperature. It should be noted that the insertion of such a mechanism changes the direction of the motion of the pipe; *i.e.*, if *ab* moves to the right *cd* will move to the left, and *vice versa*. Therefore one section or the other must be in compression, and such a compensator is applicable only to pipes. No compensator which is equally satisfactory has ever been designed for use with wires. They all require a spring or weight which takes up the slack, but if the wire gets caught somewhere this spring or weight may be pulled because its resistance is less, and then the signal does not operate. Several designs are in use and they work satisfactorily as long as the mechanism is in order.

**148. Electro-Pneumatic Signals.** The mechanical movement of signals by wires and rods is practically limited to about 2,000 feet and even at this distance it is troublesome. Electric power from batteries may be used when the power required is very small. An electro-pneumatic system uses compressed air whose power can be sent anywhere through pipes and which may be made to move not only signals but switches. The valves controlling the pistons are operated electrically by a current of

low intensity, which may be provided by batteries but which in a plant of much magnitude is more economically obtained from storage batteries which are charged from a dynamo. The operation

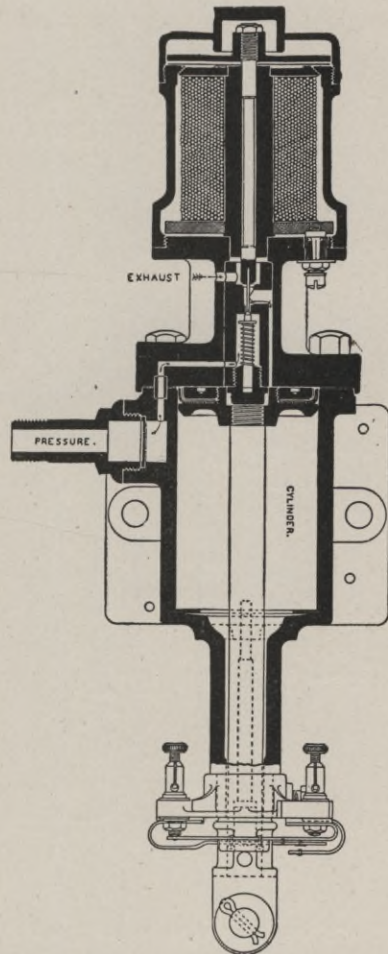

Fig. 154. Electro-Pneumatic Signal Mechanism.

of the valve is shown in Fig. 154. In the position shown the magnet is *not* energized. When it is, the armature (at the top) is drawn down, which opens the conical valve just above the spring, and the air passes from the pressure pipe through the valve and down the passage alongside of the valve chamber until it bears

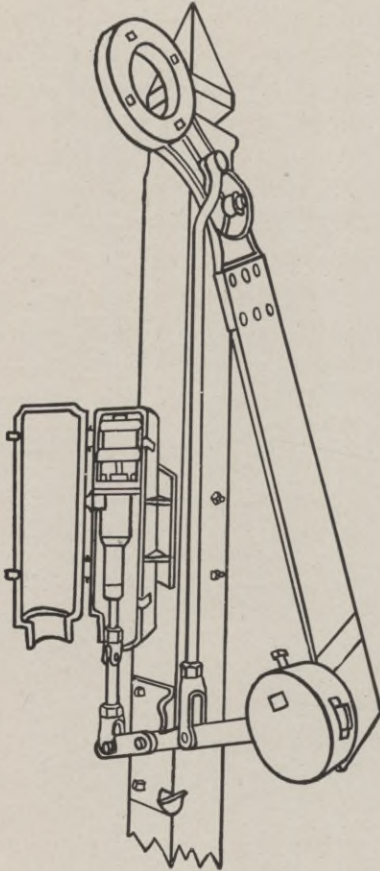

Fig. 155. Electro-Pneumatic Signal.

on the top of the piston, which is shown in its extreme upward position. When the piston is forced down, it will raise the counterweight (see Fig. 155) and put the signal at "clear." When the magnet is de-energized for *any* reason, the spring forces the valve up, the air in the cylinder escapes through the exhaust and the counterweight not only raises the piston to the top but draws the signal to indicate danger. A failure of either the current or the pressure will thus put the signal at danger.

#### 149. Electric Semaphores.

Still another modification of automatic signals is the electric semaphore, which is a semaphore of the usual type, operated by an electric motor of about  $\frac{1}{8}$  horsepower, the motor obtaining its current from a set of 10 to 16 Edison-Lalande battery cells which are placed in a box at the foot of the signal post. The motor winds up a light wire

cable which raises the counterweight and thereby sets the signal at "clear." The motor is started and stopped by the action of a relay connected to the track circuit. The track circuit has the fundamental principles previously described, but has been made somewhat complicated so as to provide for the operation of distant

as well as home signals and also the protection of and from all switches in the section. For the details of the track circuits the student is referred to the more complete works on this subject previously mentioned.

### INTERLOCKING.

**150. Principles.** The interlocking of the switches and signals of a large terminal yard is such a complicated piece of mechanism that any adequate explanation and description would require too much space here. Nothing will be attempted but a demonstration of the fundamental principle. The reason for the necessity of interlocking is simple. A mere inspection of the design of a complicated yard will show that it is readily possible to arrange a large number of combinations of different switch movements for the operation of an equal number of trains simultaneously. But the operation of such switches is controlled from a signal cabin, and unless there are limitations on the combinations a signalman would be liable to set switches and signals so that two or more trains might collide. The fundamental principle of the interlocking device is comprised in the following statements:

- (a) all switch signals are normally at danger;
- (b) no switch lever may be set for any route until the switches for any other route which might cause a collision have been locked;
- (c) the signal cannot be set to run through any switch until the switch itself is set.

Although an engineman may cause a collision by running past a danger signal, the worst that a careless signalman can do is to delay traffic. He cannot set signals and switches so as to cause a collision or even a "side swipe." The design of the interlocking machine must therefore be based on a study of the safe combinations, and then the interlocking machine must have its "cross locks" and "locking dogs" so arranged that no interference is possible. The case illustrated in Fig. 156 has purposely been made as simple as possible. The upper part shows merely the locking dogs (shaded full black) which are fastened on to the "locking bars" (which run crosswise) and the "cross locks" (shaded with cross hatching), which move at right angles to the locking bars. In the lower part of the figure are shown the signals

and tracks for a crossover from a main track. No. 1 is the distant signal, No. 2 is the home signal governing the main track with respect to the crossover, No. 3 are the switch levers which work simultaneously, No. 4 is the signal governing movement from the siding to the main track, and No. 5 is the signal governing movement from the main track to the siding. No lever for a signal or a switch can be moved without simultaneously moving the locking bar (having the corresponding number) from right to left as shown in the figure.

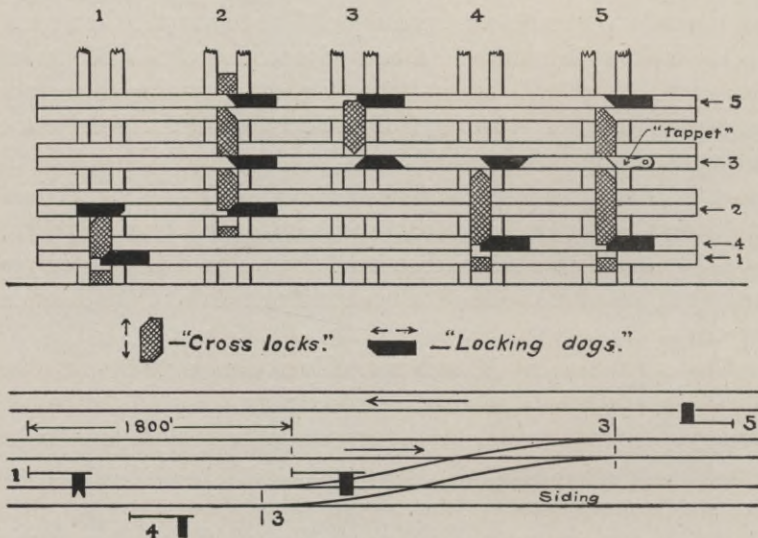

Fig. 156. Interlocking.

The wedge-shaped ends of the locking dogs will move (if possible) the cross locks with which they may come in contact. If any cross lock is immovable because it is already in contact with some other locking dog, then it will be impossible to move that lever until the lever (or levers) controlling all interfering locking dogs have been so moved as to remove the obstruction. The position of the locking dogs in Fig. 156 is that for all signals normal or at "danger." Suppose it were attempted to "clear" signal No. 1. To do so, locking bar No. 1 must move the cross lock No. 1. But this is impossible since one of the dogs on locking bar No. 2 interferes. Lever No. 1 cannot therefore be moved until

lever No. 2 has been cleared, which operation will move that dog far enough to the left so that the cross lock can move up. And this is in accordance with the principle previously stated that a distant signal should not be cleared until its home signal is cleared.

As another illustration, when the signal No. 2 has been cleared, the locking bar No. 2, by means of its attached dogs, moves the cross lock No. 2 upward. This cross lock is then set against locking dogs on each of locking bars No. 3 and No. 5 and prevents them from being cleared. Of course the signals for the crossover should not be cleared while the signal is set for a clear main track.

**Exercise.** The student should draw a modification of the upper part of Fig. 156, as it would be placed to indicate that the switch was set for a crossing from the siding to the main track. It should be noted that signal No. 4 is set "clear" when it is designed to move along the siding without using the switch, and No. 5 is set clear when the switch is set so that a train could run backward past the switch without using it. Both No. 4 and No. 5 are set at "danger" when it is designed to run from one track to the other.

The cross locks No. 1 to No. 4 inclusive are each in one piece with notches cut for the dogs. Cross lock No. 5 has the upper part separate. When the lower part is moved it does not move the upper part unless the "tappet" on locking bar No. 3 has previously been moved between the parts. The tappet is unnecessary with the simple combination of levers shown, but might be necessary with a somewhat more complicated system.

Of course the above description makes no mention of a multitude of details necessary for a manual machine, to say nothing of the complication required for an electro-pneumatic interlocking machine. But whatever the complication or how many may be the number of levers, the interlocking principle is as above.

### TRACK MAINTENANCE.

**151. Tools.** Tools should be of good quality and well designed for their use. Economy in this respect, to save initial cost, is apt to increase the labor item and since the labor costs over 60 per cent of the total cost of track maintenance, a very little



discouragement of labor owing to inefficient tools would more than overbalance any possible saving in cost. The list of tools required for the varied work of a track gang is quite large, and therefore an effort should be made to pare down the list as much as is practicable or safe, because it is correspondingly difficult for a track foreman to prevent losses due to carelessness. The following list is based on the requirements of a gang of six trackmen and a foreman.

A large proportion of the tools are for work on which not more than one or two men need work at any one time. When the list calls for six or more of any one tool, they are always the tools which are in constant or excessive use, or which are liable to become quickly broken, and of which an extra supply is a necessity for use while waiting for requisitions to make up for loss or breakage. The list is taken, with some slight modifications, from Camp's Notes on Track.

Adzes.....	2	Grindstone .....	1	Scythes—grass .....	4
Ax—chopping.....	1	Hammers—spike .....	4	“ —brush .....	4
Ax—hand .....	1	“ —sledge—16 lbs. 1		Snaths .....	4
Auger, 2-inch.....	1	“ —strike—10 lbs. 1		Shovels—track .....	8
Bars—claw .....	2	“ —nail—claw ... 1		“ —scoop .....	4
“ —crow .....	0	“ —ballast* .....	6	“ —long handle 1	
“ —pinch .....	6	Hatchet .....	1	Saw—hack, blades...12	
“ —raising.....	1	Hoe—garden .....	1	“ “ frame ... 1	
“ —tamping .....	8	Jack—track.....	1	“ hand .....	1
Brace and bits.....	1	Key—switch.....	1	“ crosscut .....	1
Brooms (coarse) ..	2	Lanterns—white....	2	Screwdriver .....	1
Brush hooks.....	2	“ —red .....	2	Spade .....	1
Car—hand.....	1	“ —green .....	2	Steel square .....	1
“ —push .....	1	Level board .....	1	Tape (50', graduated	
Car chains.....	2	“ —spirit—pocket 1		to tenths).....	1
Chisels—cold .....	2	Locks—switch—extra 2		Tongs—rail .....	4
“ —track .....	12	Mattocks .....	2	Tool box .....	1
“ —wood .....	1	Oil can—1 gal.....	1	Tool checks.....	6
Curving hooks .....	2	“ “ —2 “ .....	1	Torpedoes (with box).24	
Chalk line.....100 ft.		Oiler—squirt.....	1	Verona spike puller.. 1	
Ditch line.....150 ft.		Padlocks .....	2	Vise .....	1
Drawshave .....	1	Picks .....	8	Water pail or jug... 1	
Dippers (or cups) ..	2	“ —tamping*.....	8	Weed scuffles.....	6
Files.....	3	Punch—hand.....	1	Wheelbarrows.....	3
Flags—red .....	4	Rake—garden .....	1	Whetstones.....	4
“ —green .....	2	Rail drill .....	1	Wire stretcher.....	1
Forks—ballast*.....	4	“ “ bits .....	6	Wrenches—track .....	3
Gauge .....	1	Rule—two-foot .....	1	“ —monkey (8") 1	

\* Needed only in stone ballast.

The first comment on the above list is in regard to the bars of various kinds. *Claw bars* are used for spike pulling. The ideal design is one that would permit pulling the spike with one stroke without changing the fulcrum, and that will also pull it clear out without bending. Apparently this is mechanically impossible and in spite of the many efforts which have been made and the new designs which have been brought out, the old "bull's foot" claw bar seems to be the best.

The "*Verona spike puller*" is attached to a spike which is in a confined place (such as behind a guard rail) and is operated by means of an ordinary claw bar resting on top of the rail.

"*Crow*" bars are considered to be those which taper down symmetrically to a wedge-shaped edge at the so-called "point," in contradistinction to "*pinch*" bars on which the chisel edge is even with (or outside of) the face line of the bar. The number of crow bars is put at "0" to emphasize Mr. Camp's opinion that the crow bar form should not be used and that the pinch bar form is far preferable.

*Tamping bars* should not weigh more than 10 pounds nor should they be more than 5 ft. 3 in. long. If the handle is solid it is rather small and hard to hold. It is therefore sometimes made as a pipe, with a malleable tamper. Another form uses a wooden handle.

*Track chisels* are cold chisels provided with a handle of wood by which they may be more readily and safely held in position. They should be about  $1\frac{1}{2}$  in. square and 8 in. long, made of tool steel. A single blow may break them or render them useless until re-tempered and re-ground, and therefore a large number is necessary.

*Gauges.* These may be divided into three classes. The first is the "home-made" type of wooden gauge which is perhaps brass bound. One common objection to this form consists in the danger that it will not always be placed truly at right angles to the track. The effect of this error is to make tight gauge. To obviate this error, the "Huntington" track gauge has at one end two lugs about seven inches apart and one lug at the other end. The gauge is the distance from the single lug to the middle point of the seven-inch line, the two lines being at right angles. The device is theo-

retically perfect provided that the two lugs at the one end are both in contact with the head of the rail. A slight error in this respect will make the gauge too wide. The "Warren" gauge has two short circular arcs forming part of a complete circle, whose diameter is the gauge, fastened to the gauge bar.

*Hammers.* For section work, spike hammers should not weigh more than 8 pounds and have a length of about  $10\frac{3}{4}$  inches. The 16-pound sledge is only needed for occasional very heavy work, when it is however almost essential. The 10-pound striking hammer is the better one to use with track chisels rather than to use the spiking hammers as is so frequently done. The ballast hammers are only used for breaking up stone for ballast and are unnecessary even for this purpose if machine broken ballast of uniform size is furnished.

*Track jack.* One of these is illustrated in Fig. 107. They are certainly handy and economical tools for the track gang, but more than one serious wreck has been caused by the inability of the gang to remove the jack before the arrival of an unexpected train, and as a derailing device a jack is exceptionally effective. Track instructions generally specify that they must not be placed between the rails.

*Level board.* Such a board usually has a level tube sunk in the upper edge. At one end a series of steps are cut, each with a base of about two inches, and with risers of one-half inch, beginning at the lower edge. The discussion on the superelevation of the outer rail (see § 119) shows the foolishness of over-refinement in such work. If the required superelevation is 2.5 in., the fifth step of the board may be placed on the outer rail and the plain end on the inner rail. When the track is properly adjusted the bubble should be in the center. Of course the adjustment of the level bubbles should be carefully watched and frequently adjusted if necessary.

*Shovels.* The best shovel for track work is the short handled shovel with square point, made out of a single piece of crucible steel. The blade should have a length of about 12 in. When this has been worn down to 9 in. it should be thrown away—for track work. Its use is then uneconomical. The scoop shovels are

for handling cinders and packed snow. The long-handled shovel is for digging post holes. It should be round-pointed.

The above list includes only the tools which will be required by almost any track gang. Cant-hooks and peavies are frequently necessary for handling timber. Blasting drills, wedges, powder and fuse are sometimes needed to break up masses of rock which may have fallen into a cut. Culverts and bridge channels get choked up with timber and debris of various kinds which may need ropes and tackle to clear them. A jim-crow rail bender is occasionally necessary, although one such may be made to serve two or more section gangs.

**152. Work Trains.** The work of a track gang is usually confined to one "section," which is usually not more than five miles long, and which on roads of the very heaviest traffic may be shortened up to a mile. On exceptionally poor light traffic roads, they are made eight and even ten miles. For ordinary work their hand car and push car furnish all needed transportation facilities for themselves and materials. But there is much work which is more irregular in its character, which must be handled on a larger scale, and which requires for economy a work train. Such work is the distribution of track materials such as ties, rails and ballast from the sources of supply to the places on the road where they are needed. Also, when re-ballasting is to be done on an extensive scale, when heavier rails are to be substituted throughout, or, in short, when there is any work to be done which is beyond the routine work of keeping the track up to its normal condition, then a work train with its usual force of laborers can accomplish the work with greater economy.

The work train is usually hauled by the worst engine on the road, sometimes by one which would otherwise be sent to the scrap heap. Whatever the justification of this policy, it may be carried so far that the regular train service suffers by the inability of the work train to keep out of the way of regular traffic, or else there is the false economy of wasting the time of the work train gang while trying to save by utilizing a worthless engine. A passenger engine which may have proved too light for regular service is preferable to a freight engine, since the work train should be capable of making good speed in running to a siding and the load is usually light.

The minimum requirements for the train should include a large caboose and a flat car provided with large tool boxes for picks, shovels, bars, hammers and other track tools. Underneath the caboose may be hung a large box in which may be stored ropes, pulley blocks, chains, jacks, etc. Since the cost of train crew wages, fuel, and other expenses which must be charged up for the use of the rolling stock will aggregate about \$25 per day, there should be enough laborers attached to the train, and their work should be so planned as to justify this additional expenditure.

The minimum number of laborers should be about 20, and this should be increased to as many as can be profitably employed. Since the work of the train is scattered over a great distance, the company must choose between wasting considerable time both morning and evening while carrying the gang to and from their homes, together with many miles of train service, or of providing boarding cars, provided with bunks and one or two cars for kitchen and dining cars. One large, clean box car can be easily and cheaply fitted up as kitchen and dining car for 24 men. If the crew is much larger, one car should be devoted to kitchen and the storage of supplies and another car used for a dining car. An ordinary box car, or an old passenger car can be readily fitted up with four double lower berths and four double upper berths on one side and four lower and four upper single berths on the other side, thus accommodating 24 men. Even better accommodations may be provided when the need for such a train and gang is so regular that it will have practically permanent employment. A little extra money spent by the company in providing comforts for the men is immediately repaid in a better quality of work and less straggling off.

**153. Ditching.** While the routine clearing up of ditches is part of the work of a section gang, it will frequently happen, especially when the slopes have a disintegrating soil, and also when the slopes have been made originally too steep, that the winter's frosts will fill up the ditches to such an extent that it is best taken out with a work train gang. Ordinarily the section gang would need to load such material on their push car or on wheelbarrows and run the material out to the end of the cut where it may be harmlessly wasted. If the cut is very long, such hauling would



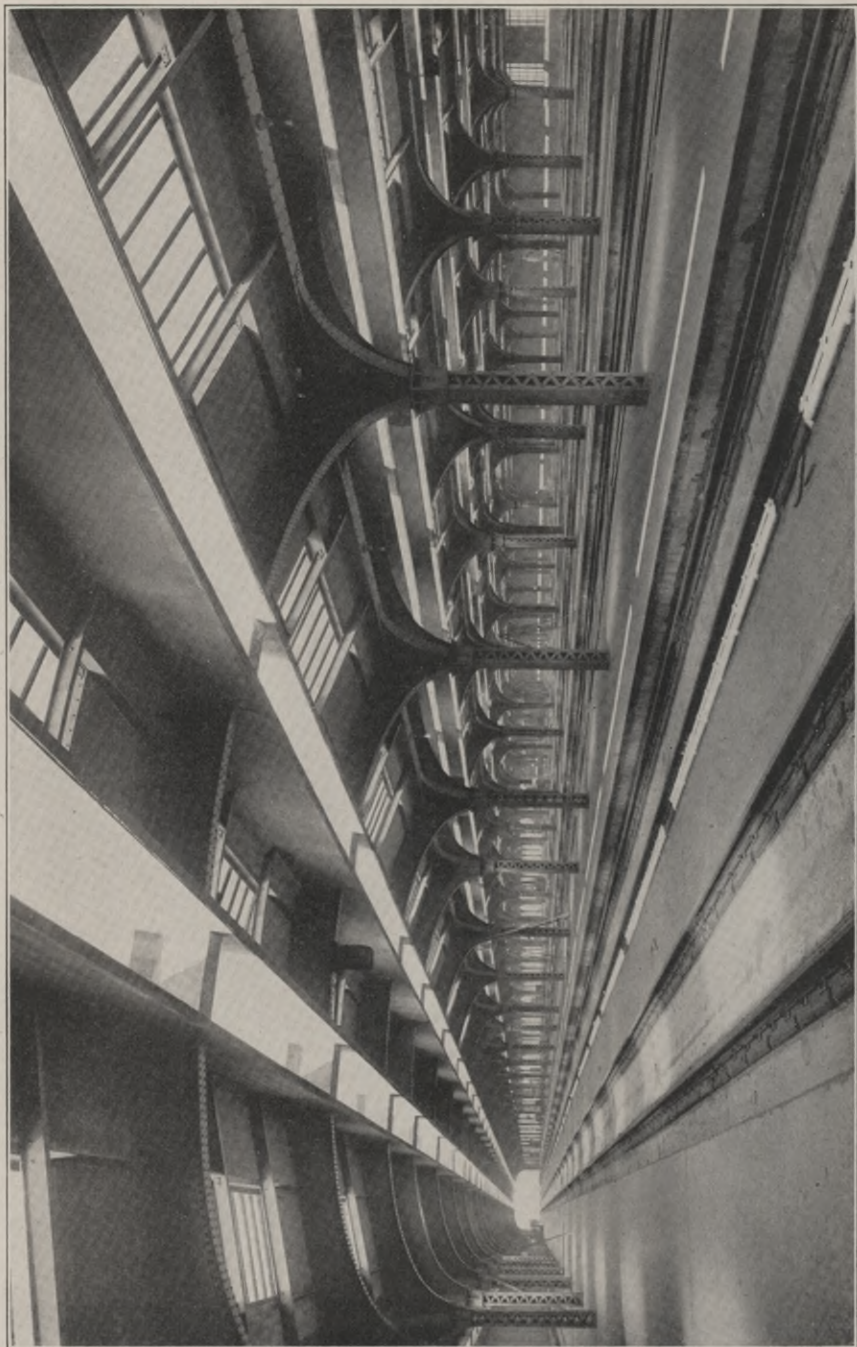

**BUSH PATENT TRAIN SHEDS, CHICAGO AND NORTHWESTERN RAILWAY DEPOT**  
Construction Is Entirely of Steel and Concrete. Smoke Stacks of the Engines Follow the Slits in the Roof, and Thus Avoid Filling the Train Shed with Their Smoke.  
*Charles S. Frost, Chicago, Architect. George A. Fuller Company, Contractor*

be very expensive. Since the regular schedule will not usually permit the train to stand long on the main track, especially on a single-track road, the loading must be done in the shortest possible time. This usually implies that a part of the gang should remain at the cut while the train is running off to unload and that they should all work there if the train must run to a siding merely to let a regular train pass. During such times the men can scrape down all loose material from the side slopes and loosen up the filling in the ditch, so that it is all ready for shovelling when the train arrives.

When the cuts are not very deep, such material is sometimes thrown up on the top of the bank, even by using a temporary staging on which the earth is thrown and then again shoveled to the top of the bank. In any such case the earth should be thrown well back from the edge of the bank so as to guard against its being again washed into the cut. It also should not interfere with the surface ditch which should have been cut on the top of the bank to prevent surface water from the slope above from running down into the cut.

**154. Distributing Ties.** The methods to be used necessarily vary with the sources of supply. If ties were obtainable from farmers and were delivered along the right-of-way on every section of the road, very little if any distribution by a work train would be necessary. When, as the other extreme, there is no local source of supply, the ties must be hauled many miles and so distributed that subsequent distribution by the trackmen will be reduced to a minimum. Since economy requires that ties shall only be replaced by an actual count of those which are defective, an essential preliminary is that a marker shall be placed along the track for every ten ties required, or that the number required between two consecutive telegraph poles shall be marked on the poles so that it may be seen as the train approaches. By this means ties may be thrown off as required while the train is moving at a speed of about six miles per hour. On light traffic roads the work of tie distribution is frequently done by the local freight train. While this may be and often is the best policy, the cost per tie is much greater.



**155. Distributing Rails.** The method of handling rails depends very largely on the cars on which they are loaded, and also on their length. They are dropped off most easily when loaded on to flat cars, but frequently they are loaded on to gondolas and even in box cars by making a hole in the end of the car. Rails of 45 and 60 feet can only be loaded on to two consecutive flat cars. If they are being unloaded in one place simply for storage, a derrick of some kind, even though temporary, is wise economy. For distribution along the track they are either dropped over the side of the car or pulled off from the end. If they are dropped over the side they are apt to be kinked. Sometimes they are slid off on skids made of two timbers or pieces of rail about 10 feet long, but this is impracticable in some localities and it lands the rail at some distance from the track. The car to be immediately unloaded may be placed at the extreme rear of the train. Then a rail hook attached to a sufficient length of rope may be hooked into one of the bolt holes and the rail may be drawn off the end. By placing a "dolly" on the end of the car the rail may readily be drawn off by hand. As soon as the center of gravity passes the dolly, the outer end falls easily to the track and then, pulling the train ahead, the other end is let down easily as it drops off. Sixty-foot rails are so flexible that a considerable part of the length will be resting on the ground before the other end leaves the car, and will not be injured by dropping on the ties.

When the rails are especially long and heavy, an easier method is to hook on the rail-hook and attach the ropes to a track rail or around a tie. Then let the train move ahead until the rail is drawn off. Even the dolly under the rail at the end of the car is unnecessary with this method. If rails are needed for both sides, two such ropes and hooks may be used simultaneously. With a little more care this may be so done that the end of each rail comes almost exactly at the required joint, even allowing for staggering the joints on the two lines of rails. By attaching a push car to the car carrying the rails, the rails may pass over that and down on to the ground without any danger of injury from the drop.

The reverse operation—loading old rails onto a car—is heavy and costly work when done by hand. The best plan is to do it by means of a derrick. If it must be done without such aid, it facili-

tates the work to make an inclined plane by attaching a push car to the flat car on which the rails are to be loaded, and then by placing several dollies on this plane, the rails may run up on rollers with a minimum of actual lifting. It might be thought that a 70-lb, rail, 30 feet long, which weighs 700 pounds, should not be an excessive load for six men. When the men are carefully drilled to lift together and simultaneously raise the rail above their heads and throw it with machine-like precision on to the car, it may be (and is) successfully done in this way, but if one or two men shirk or do not lift with the others, the load is concentrated on the others. They successively become frightened and, to save themselves, "jump from under"; the remainder cannot sustain the load and it falls. It is lucky if someone does not have a foot crushed. The longer and heavier rails cannot be handled in this way.

**156. Handling Ballast.** A railroad must consider itself unfortunate if it does not have a gravel bank at some place along its line. The bank generally extends into the adjoining property, which is either bought outright or the gravel privilege is bought. The last method generally specifies that the top soil shall be reserved and spread upon the excavation after the gravel is exhausted. The gravel is usually overlaid with more or less vegetable soil. Sometimes the amount of this is so insignificant that its presence may be ignored, but if the depth is appreciable it will pay to strip it. A spur track whose minimum length is the length of the train must be run off from the main track. The method of attacking the bank depends on the method of digging—whether by steam shovel or by hand digging and shoveling.

About twenty cubic yards per day may be considered a fair day's work in loading gravel cars at the pit. A steam shovel with a dipper holding  $1\frac{1}{2}$  to 2 cubic yards can load 800 to 1,200 cubic yards per day, depending on the prompt handling of the cars when loaded. Even this figure has been greatly increased under exceptionally favorable conditions. But the use of a steam shovel implies the use of a locomotive, which must be constantly at the pit shifting the cars so that there is a car constantly in place within range of the shovel. The cost of running such a shovel with its attendant locomotive will be about \$50 per day. This will pay about 40 laborers who could dig about 800 cubic yards. Therefore, unless

the circumstances are so favorable that the shovel can exceed 800 cubic yards per day, the work may be done about as cheaply by hand shoveling. This is, however, about the limiting case. With good management a large shovel can take out gravel much cheaper than it can be done by hand. 20 cubic yards per day at a labor cost of \$1.25 per day makes the gravel cost about six cents per cubic yard loaded on the car at the pit. The average cost of such hauling on a Western railroad was computed by the management to be 0.35 cent per cubic yard per mile. In this case the quantity handled was very large and the cost may be considered exceptionally low.

When the work is done on a small scale, and especially when the gravel is loaded by hand, hand methods would be used for unloading, but there is great economy in the use of a plow for unloading. This implies the use of flat cars, which are in fact almost universally used for ballast work—barring the special patented ballast cars. The plows are “center unloading” or “side unloading,” and some of the most recent forms are adjustable so that they will unload all to either side or will unload to both sides in any desired proportion. The plow is drawn over the tops of the cars by a cable. The cheapest method is to stop the train where desired, set the brakes, uncouple the locomotive and attach to it a  $1\frac{1}{4}$ ” or  $1\frac{1}{2}$ ” wire cable. Commencing with the plow at the rear car the locomotive moves ahead and draws the plow over all the cars. This method has many objections, especially when it is done on curves. A much better method is to have a car carrying a hoisting engine, which may be supplied by steam from the locomotive by a flexible tube, if the car carrying it is placed immediately behind the locomotive, or preferably which is supplied from its own boiler placed on the car. A wire rope from this engine hauls the plow. One great advantage of this method lies in the fact that the train can be kept moving if desired while the plow is working.

If it is desired to distribute less ballast per car length than the car load, it may be done by moving the train ahead at just such a speed that will give the desired result. Incidentally, this method is very useful when making a fill from a trestle or to fill up a washout. By putting the plow at the rear of the train and drawing the plow backward, the speed of the train and of the plow can

be so regulated that the material will be deposited with as great concentration as desired. If it is desired to fill up a hole, the whole train load may be deposited in one spot by simply hauling the plow back as fast as the train moves forward. The average cost of thus unloading with a cable has been computed as about one-half cent per cubic yard. During recent years many styles of ballast cars which are easily and automatically unloaded have been placed on the market. Some of these have been designed with the distinct idea of being used in connection with local freight trains. They are picked up at the gravel pit by a local freight going in the desired direction, are hauled to places along the road which have been previously marked with stakes, are dumped with a delay of only a minute or so, then hauled on to where they may be sidetracked and hauled back to the pit by another local freight. Gondola and coal cars having hopper bottoms are also used extensively for hauling ballast.

**157. Trestle Filling.** This has become a very common form of work for the work train. When the construction of a railroad is once definitely decided and work is begun, any measure which will hasten the opening of the road for traffic has a very high money value. Therefore trestles have been built where embankments are a better form of permanent construction. The preliminary construction of trestles is further justified by the fact that the immediate construction of an embankment would often involve very expensive hauling with teams from borrow pits in the neighborhood, while a future fill may be made by the train load, as described below, at a much less cost. Incidentally, time is allowed to determine the maximum water flow through the hollow crossed by the line, and the size of the culvert required may be more accurately determined. The cost of the culvert, which may be very considerable, is also deferred to a time when the road can better afford it. At the time that many existing trestles were built the cost of timber in their localities was so small that the trestle may have been actually cheaper.

Many roads are now confronted by the necessity of either replacing the trestle or filling in with earth. While the relative cost is very variable, depending on the local price of timber, the proximity of a sufficient supply of available filling and the methods

to be employed, yet as an approximate figure it may be said that fills as high as 25 feet may be filled with earth as cheaply as a trestle can be reconstructed. But when it is considered in addition that the average amount of timber required annually for repairs of trestles is about one-eighth of the volume, also that the labor involved in maintenance is very great while it is almost insignificant on an embankment, also that the danger of accident on a trestle and the disastrous results of a derailment which may occur on a trestle is so much greater than on an embankment, the height at which it becomes economical to fill with earth instead of reconstructing the trestle increases until it may reach 50 feet. But the filling in of high trestles involves several special constructive features. The hollow may have at the bottom a very soft soil which cannot sustain a heavy embankment without considerable settlement. Such a settlement will prove destructive to almost any culvert unless a solid foundation may be made for it. Under such conditions a pile or concrete foundation for the culvert may become a necessity.

The dumping of earth and particularly of boulders, stumps and clods of frozen earth may do serious injury to the trestle unless means are taken to guard against it. This may be done by placing an "apron" on each side which will deflect the earth so that it falls outside the trestle. As the piles grow on each side the intermediate space will be filled up. The longitudinal braces which are most apt to suffer are sometimes strengthened by heavy timbers, which may be old stringers, etc. The filling should be done regularly along the length so that the bents will not be forced out of place by an unsupported pressure of earth on one side. If the bank is formed merely by dropping earth loosely from above, its slopes will be steeper than can be retained permanently. The result is frequently a disastrous slip. This feature justifies the spreading of the earth by scrapers as the filling proceeds. This method has the additional merit of packing the earth so that there is almost no settlement and the stringers may be pulled and the ballasted road-bed may be constructed very soon after the filling is complete. Otherwise the settlement is so great that six months or a year must elapse before track laying is permissible. During this time

the embankment may settle 10 per cent. This earth-spreading may be done for two or three cents per cubic yard.

The choice of filling material is an important matter. A sandy or gravelly soil is the best. Clay is apt to be very troublesome, for, no matter how hard it may be in dry weather, it will slip and run when it becomes wet. This is especially true when the base of a fill is on a steep side slope. In this case the whole fill may slide down the hill. One means of preventing this is to dig trenches along the slope. Even plowing the surface in contour furrows may be sufficient to prevent such a slip. The material for such a fill will usually come as the spoil from a widened cut, loaded perhaps with a steam shovel into dump cars or on to flats from which it is scraped by a plow, as previously described.

The practice of immediately planting tufts of Bermuda grass and even tree slips which will take root and grow and thus bind the embankment together as well as cover it with a surface of sod which will protect it from rain-wash is a measure of true economy which always pays. The total cost of such a fill must combine the cost of loading, hauling, spreading (if it is done) and the other expenses incidental to making a finished embankment, but the record made by many roads on these items show that it may be done at very much less cost than by the methods which are usual or possible during the original construction of the road.

**158. Organization of Track Maintenance Labor.** Although there is much variation in the practice of roads as to the succession of authority among the higher officials of the road, there is a very general agreement in placing the immediate supervision of the track for each division of approximately one hundred miles under a man known as roadmaster or perhaps supervisor. Some roads extend the authority of the roadmaster over a greater length of road and then appoint "supervisors" who individually control shorter lengths and who report to the roadmaster. The supervisor of each minor division superintends the work of the several section gangs in his division.

The roadmasters usually report to a division engineer, but except in matters of exceptional importance or which may involve new methods of work, the roadmaster is expected to do his routine work without special orders and to be responsible for its proper

execution. The roadmaster should be thoroughly conversant with every phase of the work done under him, and although it is preferable that he should have come up from the ranks, he should have a far better education than is possessed by the large majority of track laborers. The best roadmasters are those who have a technical education but who have served a sufficient time in the ranks to have become familiar with the practical details of track work. The Southern Pacific R. R. Co. require a roadmaster to "pass over the entire straight portion of his districts, either on foot or on velocipede cars, at least twice every month, and over that portion in canyons and in the mountains at least three times per month." He should have the work of the entire division so thoroughly mapped out in his mind that he has a sufficiently clear idea of the condition of every part of his division at any time and thereby save himself from censure due to any neglect of the track work at any place.

The most effective way to do this is to have the section foremen under such a state of drill that there will be no failure to remedy any slight defect or report a greater one. The roadmaster must rely on his discipline of the section foremen rather than on his personal observation, although he should not relax any effort to make his personal observations as thorough as possible.

The section foreman should generally be a man who has served his time as a track laborer, but he should also be a man who has sufficient education and intelligence to make out reports and correctly interpret plans and tabular statements. Another absolutely essential quality is an ability to control men without violence or abuse. He should not only thoroughly understand all the details of maintaining a track in condition, but should be able to repair a track and make it safe for trains in any ordinary emergency such as a broken rail, a washout, or a tearing up of the track due to a wreck. He should familiarize himself with all rules of the road regarding train running with which he may ever be immediately concerned, and also with all rules and standards of track construction which may have been adopted. The last qualification, which is becoming more and more essential, raises the standard for section foremen above what was formerly considered necessary.

Many roads require (by their rules) that the foreman shall take part in the manual labor of the gang. The wisdom of this rule depends somewhat on the work being done and on the number of men in the gang. If there are as many as eight laborers in the gang, the foreman may have all he can do in directing them. It is frequently advantageous to have the men work in pairs, and when the work is light, it may be best to have five laborers with the foreman in a gang, and then the foreman may work with the odd man.



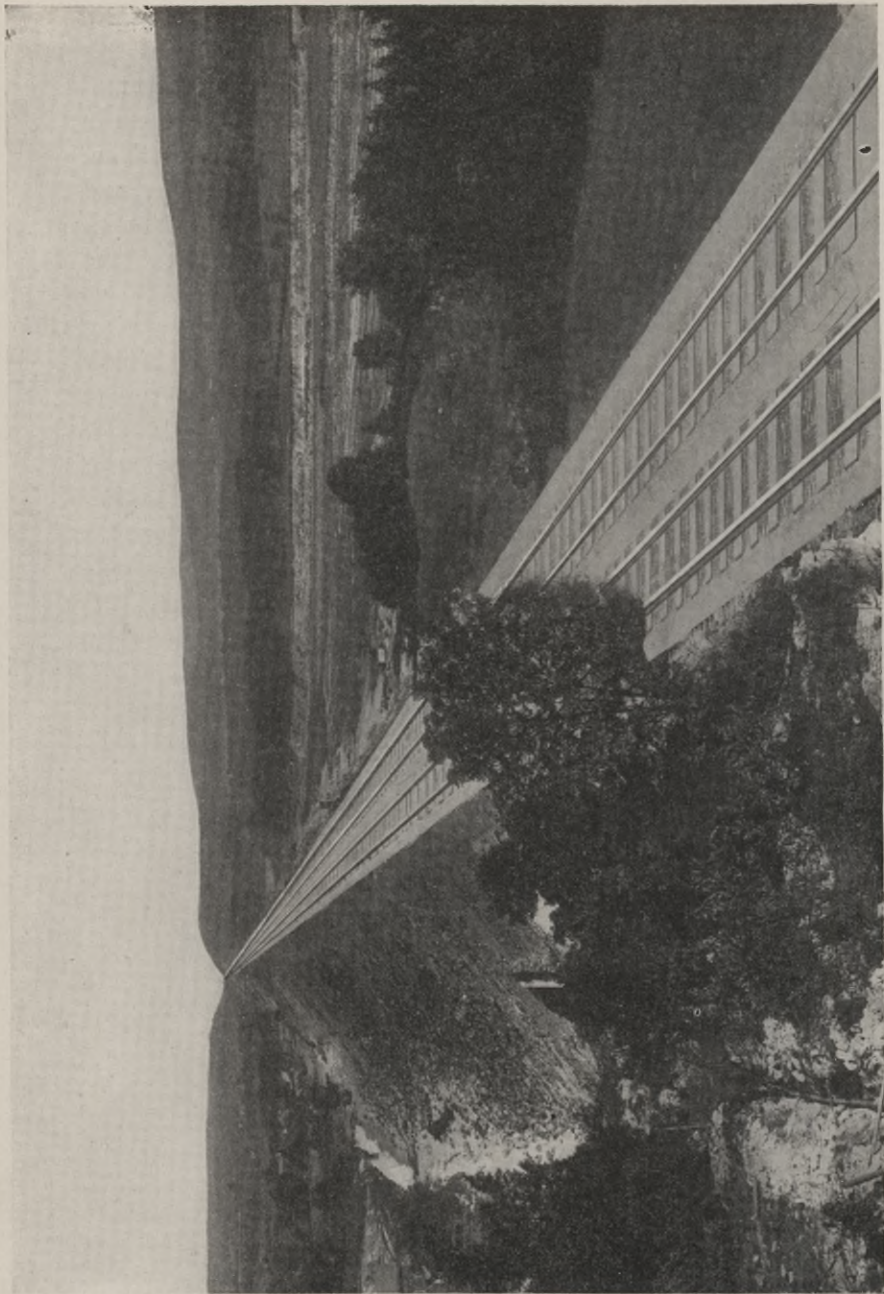

**FAMOUS CUT-OFF ON DELAWARE AND LACKAWANNA RAILROAD WHICH SAVES ELEVEN MILES BETWEEN NEW YORK CITY AND BUFFALO**

This is said to be the largest fill in the world. Its maximum height is 110 feet and it contains approximately 6,000,000 yards of material.

# RAILROAD ENGINEERING

## PART III

---

### ECONOMICS

#### RAILROAD FINANCES

**159. Capitalization.** Practically all of the following statements regarding capitalization, etc., of the railroads of the country are taken from the reports of the Interstate Commerce Commission and may, therefore, be considered as reliable as any which are obtainable. Many of the following figures are taken from the report for the year ending June 30, 1912. At that time the capital stock was given as \$8,622,400,821. Disregarding the fractions of millions, the funded debt, expressed in millions, was 11,130, or a total capitalization of 19,752 million dollars. This represents approximately one-tenth of the national wealth. The "investment in road and equipment", to June 30, 1912, was stated as 16,004 millions. Unfortunately the finances of railroads have been so manipulated that any statement of "cost of road" does not usually represent the capital actually spent on construction.

The above figures apply to 237,467 miles of line, the total mileage being nearly 247,000 miles. The railroads directly employed 1,716,380 employes, to whom they paid over \$1,252,000,000, which was over 44 per cent of the operating revenues, amounting to more than \$2,842,000,000. The employes represent a population of perhaps eight millions who are directly dependent on the railroads for support. Considering the industries, such as locomotive and car shops, which depend entirely on railroads for business, and also the industries, such as steel mills and bridge works, which have railroads as their largest customers, it may perhaps be estimated that one-fourth of the entire population of the country are directly or indirectly dependent for their support on railroads.

If the argument is carried still further and the fact is recognized that a very large proportion of the products of agriculture,

mines, and manufactories could not otherwise be transported to consumers, or would not be utilized and, therefore, would not be produced, the debt of the country to railroad transportation may be better appreciated.

Although the stocks and bonds of many of the smaller railroads are owned by large corporations in their corporate capacity, yet of the total of 19,752 millions of stocks and bonds outstanding in 1912, 13,986 millions, or about 71 per cent, were owned by "other than railroad corporations"—chiefly private investors. On the basis of total assets of 19,752 million dollars and an estimated population of 95,172,000 people, the *average* ownership is over \$207 per head of population. The total operating revenue of over \$2,842,000,000 represents an average payment of nearly \$30 per inhabitant, for the year. The "number of passengers carried one mile" was 33,132,000,000, which means that the *average* passenger traveled 348 miles during the year. The average number of passengers on a train was 53 and they traveled an average journey of 33.18 miles.

The "number of tons of freight carried one mile" was 264,080,000,000, which means that the *average* inhabitant supplied a freight business equivalent to moving 2775 tons one mile, or moving one ton 2775 miles, or moving 50 tons 55 miles. As an aid to grasping this perhaps incredible statement combined with the statement of an average annual payment of \$30 per inhabitant, it should be remembered that whenever a ton of coal or even a pound of sugar is bought, the price paid includes payment made to a railroad company for freight.

While the above figures must be considered simply as averages, and not necessarily applicable to any one road, they give some idea of the magnitude of railroad business and what the *average* railroad may be expected to do. Considering, however, that the great railroads of the country are already built, and that the roads yet to be built will probably be of minor importance, even such an average statement could hardly apply to any new enterprise except with a very large discount.

**160. Stocks and Bonds.** An ordinary mercantile business, or even an ordinary factory is conducted on the capital directly furnished by the owner or owners. Therefore any profit over

the operating expenses may be applied as dividends no matter how small the percentage. Very few of the railroads of this country have been constructed, even approximately, on this basis. Usually a large part of the virtual ownership of a railroad is represented by bonds. The limit of the issue of the bonds may be that which expresses the confidence of the public in the enterprise, or, in other words, the value which it is assumed that the whole property could be sold for under a foreclosure sale.

During the early history of railroading, when railroads were being run through well-established communities which were without railroad facilities, the success of the enterprises seemed so certain that little or no difficulty was experienced in borrowing on bonds capital sufficient, and even more than sufficient, to construct and equip the road complete. But such opportunities are practically past. The capital stock actually paid in represents the margin, or the uncertainty between what it actually will cost to build the road and its estimated foreclosure value. The nominal issue of stock is usually about equal to the issue of bonds. In 1912, the ratio was 86 to 111.

At its best, the inception of such an enterprise means a considerable outlay of money. A group of men, acting on the belief that a road passing through certain towns will be a profitable enterprise, forms a temporary organization, develops the enterprise, has surveys made, and then if the developed plans still look encouraging, has bonds engraved and placed on the money market for sale, usually through a financial syndicate. Even if it were possible to raise enough money for actual construction, the amount of money required for this preliminary work, although but a small percentage of the gross amount required, is sometimes a large sum of money.

The gross amount required is increased by the frequently ignored fact that a road does not attain its "normal" traffic for five or ten years after it begins operation, and unless it has sufficient funds as "working capital" to tide over the initial period when it does not perhaps pay operating expenses, it is very apt to go into the hands of a receiver.

Stocks and bonds may therefore be considered as representing two forms of ownership. The interest on the bonds is a lien on the receipts, after the operating expenses have been paid. Such

interest must be paid in full before any dividends on stock may be paid. The security of the bonds is therefore comparatively good, and the profit comparatively certain although it is small.

On the other hand, the stocks are much more speculative. No dividends are paid until the operating expenses and the bond interest are fully paid; and if the latter is not paid, the bondholders have a right to demand that a "receiver" be appointed and if necessary that the road be sold. Since such a sale will not usually realize more than the face value of the bonds (and sometimes not even that), the stockholders may lose their entire investment. But if the road makes money, the excess which may be allowed for dividends may be a very large return on the amount of capital *actually paid in*. It may very easily be shown that a comparatively small change in the amount of business done may suffice to change a good profit for the stockholders into an actual deficit, which makes a receivership dangerously probable.

The relative profit on stocks and bonds and the fact that railroad securities, although sometimes very profitable, are very precarious in value is shown by the following statements: The year ending June 30, 1902, was the best year (up to that time) ever known in the railroad business. But, in spite of this, 44.6 per cent of all railroad stocks then in existence paid *no* dividends. The average rate paid on dividend-paying stock was only 5.55 per cent. Even granting that much of railroad stock is "watered"—which means essentially that it represents little or no cash actually paid in—the fact remains that during that year 44.6 per cent of all the stock issued paid no dividends. From 1895 to 1897, over 70 per cent of all railroad stocks paid no dividends.

The record regarding bonds is much better, the percentage of the entire bond issue which failed to pay anything during 1901-2 being less than 5 per cent. While it is true, almost without exception, that a railroad builds up the section of country through which it passes and increases its value far beyond the cost of the road, yet it is also true that very few roads which are old enough to have a history have escaped a receivership at some time in their growth, even though they may now be gilt-edged properties.

**161. Gross Revenue.** The estimation of the probable volume of traffic or the gross revenue of a proposed road can only be approx-

imated at best and even this requires experience. Since it requires five years or more for a road to attain its normal traffic, investors should not be disappointed when the returns for the first few years are less than those anticipated.

The only practicable method of estimating traffic is to study the resources of the belt of country which will be tributary to the proposed line, estimating the business obtainable from every factory, mine, blast furnace, farm, village, etc. When, as is usual, the line passes through or reaches cities which are already supplied with railroad facilities, the detailed computation of business becomes very uncertain. But if the chief business of the road is to develop local business along a route which has no other means of communication, then the computation is easier. The two dangers in the method lie in the entire neglect to allow for certain important sources of income and, on the other hand, to overestimate the income from a certain source. Analogous to the last is the neglect to allow for present or future competition, which may practically cut off sources of income.

Although some idea of the product of factories and mines may be obtained from records as to their present or prospective output, the income from passenger business can only be computed from comparisons with other roads. The freight business is generally two-thirds of the business of a road, except on those roads which have an enormous suburban traffic. The average receipts per passenger mile are about 2 cents, but it is the enormous commuter business and the growth of travel on 1000-mile tickets which bring down the average to this figure from the usual charge of 3 cents per mile and the even higher charges on roads with light traffic and very heavy expenses.

As a rough check on the above method the annual reports of the Interstate Commerce Commission give the gross earnings from operation for the road in each of three sections into which the country has been divided. Dividing this gross value by the population of the section (which is deducible from the report) an *average* value per head of population for that section is obtainable. The value for the whole United States is, as previously stated, nearly \$30, but the value for some one section may prove quite different from this. Multiplying the value obtained by the population

which may be considered as tributary to the route of the road, we have a very approximate value for the income of the road. The two obvious weaknesses of the method are that the receipts of the proposed road may prove very different from the average for that section and also that the computation of the tributary population is a very uncertain calculation. But since the method may be easily tried, it furnishes a check of some value.

As a better check there are usually one or more roads which may be selected which have substantially the same characteristics and whose incomes per mile of road are nearly equal and which supposedly equal the expected income of the proposed line. Assuming the existence of such roads and that the engineer has sound judgment in estimating their characteristics, this method should be employed if possible, at least to check the value of any other computation.

The number of passengers per train is of course very uncertain. The average number of passengers carried for each passenger-train-mile, as previously stated, was 53, which is less than a car load. And when it is considered that even this average includes the heavy traffic roads and the well-filled trains on suburban roads, the average number on a light-traffic road must be very small. The number of passenger trains per day bears but little relation to the number that can be carried in one train load—as the above (53) shows.

The passenger business must be developed, coaxed, and encouraged, which can only be done by a frequency of service which is usually far ahead of the requirements from a mere hauling standpoint. It is a very poor road which cannot afford two passenger trains per day each way. The total number of passengers carried might not suffice to fill one car, but it would probably be a far greater number than would be hauled if there were only one train per day. The criterion for an increase in number would appear to be as follows:

When it may be shown that the increase in facilities due to an additional train will so encourage traffic that the additional receipts will equal or exceed the cost of the additional train (which will be less than the average cost per train-mile), then the added train will evidently be justified.

The average revenue per passenger-train-mile for 1912 was

given as \$1.29, which includes receipts from mail and express, as well as passenger receipts. The average receipts per freight-train-mile was \$3.02, or more than twice as much, and this, in spite of the fact that a passenger, weighing perhaps 150 pounds, paid 1.987 cents per mile, while a ton of freight paid 0.744 cent per mile. This great difference is partly due to the fact that the ratio of dead load to live load in freight is about 1 : 2, but on passenger trains it may be 5 : 1 or even 10 : 1. Another reason is that freight trains are made up, if possible, so that each engine is hauling about the limiting number of cars that it can handle (so as to reduce the number of trains required) while, as stated above, passenger trains are run frequently, and light, so as to encourage the passenger traffic.

**162. Monopoly in Railroad Business.** One danger to be considered in the estimating of gross revenue, and also in the subsequent designing of the road and in the facilities offered for traffic, is the assumption that the road "will have all the traffic there is". Even ignoring the effect of possible future competition, which may be encouraged and somewhat developed by a marked lack of facilities on an existing road, it should be recognized that a large part of the traffic depends directly on the facilities offered. A factory's very existence depends on its ability to collect its raw material, manufacture it, and deliver it at the door of the average consumer, perhaps in a distant city, as cheaply as other manufacturers of the same article. Under close competition, an increase in one single item of expense, such as cartage from the factory to the railroad, may make up the difference between profit and loss.

The ideal location for a railroad is that it shall pass through the heart of the manufacturing district of any city and that its passenger station shall be located in the immediate neighborhood of the business center of the city. The purchase of such property for tracks and stations after the city is well established is of course very expensive, but the disadvantages of a location which is considerably removed from the ideal location are very great. These disadvantages are so increased under competition that a road's traffic may be practically ruined. Even the passenger business is greatly affected. The passengers who will travel anyway regardless of inconveniences are comparatively few.



The most important practical feature of this question lies in the fact, referred to before, that the margin between profit and loss is very small, that a very large proportion of the gross revenue must be paid out for operating expenses, that nearly all, if not quite all, of the remainder goes to pay interest on the bonds and only a small, doubtful percentage remains for dividends. Therefore, the dividends come literally from the unnecessary traffic which must be coaxed and which will not travel on a road which lacks conveniences.

The force of this may be seen still more by considering the easy financial condition of a well-established road. The receipts are large and are partly spent in creating still further conveniences, commodious and convenient stations, better rolling stock, etc. These in turn encourage more traffic, which still further increases receipts, until there seems to be no end to the financial ability of the road. Such roads are the Pennsylvania, the New York Central, and some others. On the other hand, the poverty of a road begets a poverty of service which still further decreases receipts until ruin is in sight. Many a road has been practically compelled to supply free cartage for freight (or allow for it by a rebate) to compensate for an inconvenient freight station. Since the Interstate Commerce regulations now prevent rebates, railroads having inconvenient locations for stations or terminals do not have even that method of compensating their handicaps. The enormous sums paid to bring passenger terminals into the heart of a great city are instructive examples in this respect.

**163. Division of Gross Revenue.** Of the more than 2000 railroad corporations listed by the Interstate Commerce Commission, a very large number of them are so merged with the corporations operating them that their separate existence is only evident on paper. The capital stock of many of them is partially or entirely owned by the operating company and they are operated under a great variety of leases, etc. It is therefore difficult to obtain from the financial statement of any of the large corporations the division of gross revenue. The following case is fairly typical of a simple, independent railroad corporation:

It is an independent road 371 miles long, with a capital stock of \$1,114,400 and a funded debt of \$9,415,000, which is made up of bonds to the amount of \$8,555,000 and "equipment trust obli-

gations" to the amount of \$860,000. This is evidently a case of a road built chiefly on the proceeds of the bonds, the issue of stock being quite small. The gross revenue for 1901-1902 was \$1,708,937. Of this, \$1,101,884 or 64.5 per cent was spent in operating expenses. Of the remainder, \$552,821 or 32.4 per cent was needed for the "fixed charges". This left only \$54,232 available for anything else. Although this amounted to nearly 5 per cent on the rather small issue of capital stock, no dividend was declared. It was evidently preferred to add this amount to their working capital or perhaps to use it in improvements. Such an action is virtually the reinvestment of profits for the improvement of the road.

The complication, due to the corporate ownership of railroad stocks and bonds, as well as other income-bearing property, by railroad corporations, makes it impossible to analyze the financial statements of most railroad companies as easily as has been done above. A disbursement item by one corporation is an income item for another corporation. The Interstate Commerce Commission publishes each year a statement which analyzes the reports of all the roads of the country and considers them as one system, which is done by eliminating all but the net balance of all intercorporate payments. Some of the items of the statement for the year ending June 30, 1912, are as follows:

	(Millions)
Operating revenues (rail operations).....	\$2,842,
Operating expenses (rail operations).....	1,972,
Total net revenue (adding a million from "outside operations").....	871,
Taxes accrued.....	120,
Operating income.....	751,
Other income (chiefly dividends and interest on stocks and securities owned).....	89,
Gross income.....	840,
Deductions from gross income (chiefly interest on funded debt and net intercorporate balances).....	488,
Net corporate income for year.....	352,
Adding balance of profit and loss, June 30, 1911.....	1,124,
Gross surplus, June 30, 1912.....	1,477,
Net loss during year (from "adjustments, through profit and loss")....	30,
Surplus available for appropriation.....	1,447,
Net dividends declared during year.....	\$299,
Appropriations for extensions and betterments.....	\$ 53,
Balance, carried to general balance sheet.....	\$1,095,

Although it may appear ultraconservative to have allowed dividends of only 299 millions when the "surplus available for appropriation" was nearly five times that amount, it should also be noted that the net balance carried over was but little over one-half of the annual operating expenses. The balance, after paying interest charges for the year, would not run the roads four months if all income were cut off. While this is an inconceivable contingency, the margin for working capital is none too large. Even this margin was reduced 30 millions during the year.

**164. Fixed Charges.** The fixed charges of a simple railway corporation which operates only the line which it owns will consist chiefly of the interest on its bonds. Besides this there may be the interest on "equipment trust obligations" which are merely a particular form of bond issued to pay for equipment needed by the road. Another item will be the interest on sundry interest-bearing current liabilities; this is generally but a small percentage of the fixed charges, but the current liabilities are often made to disappear by a new issue of bonds which take up an old issue and at the same time cover all floating liabilities.

The complicated financial relations existing between operating roads and their leased lines introduces some other items which are entered under fixed charges. One of these items, which is always less than 1 per cent of the total fixed charges, is called "salaries and maintenance of organization". These refer to the salaries which are paid to a few of the general officers of a leased road who are retained to continue such work. Another item is placed, when it occurs, among the fixed charges; this is the rental paid for a leased road. As this is an "intercorporate" payment, it did not appear in the above general summary for the roads of the United States, nor did it appear in the detailed statement of the road previously described, since that road had no leased lines.

**165. Net Revenue.** The net revenue is that which remains after the operating expenses and fixed charges have been paid. In general it is available for dividends, but practically a very considerable proportion of it will be devoted to improvements or to the accumulation of a surplus which will serve as "working capital". During the year 1911-12, 34.57 per cent of railroad stock paid *no* dividends, although the case quoted above is but one of many in

which there was a considerable surplus after paying the operating expenses and fixed charges. Dividends of less than 4 per cent were paid on 2.67 per cent of stock.

This small proportion shows the tendency to pass the dividend unless it may be made larger. About 49 per cent of the stock paid dividends varying from 4 to 8 per cent. This represents the bulk of the stock paying normal dividends. Smaller percentages of the stock paid higher rates. On 8.43 per cent of stock, dividends of 10 per cent and over were paid. Of course this last represents roads which are short and very exceptional in character. It should also be kept in mind that the percentages of dividend-paying stock quoted above are almost the highest of any in the history of railroading. If general railroad conditions should ever return to those existing in 1896, when over 70 per cent of all the stocks paid no dividends, railroad stock would be less attractive for investment than now in spite of the abnormal profits which are occasionally realized.

**166. Operating Expenses. Uniformity per Train-Mile.** The classification of operating expenses here adopted will follow, both in general and in detail, the classification used by the Interstate Commerce Commission. The figures given will, in general, be *averages*. This is further justified by the very remarkable fact that the expenses *per train-mile* are nearly constant, whether the trains be few or many, heavy or light. Of course there are very numerous exceptions to this rule, but it will generally be found that the marked exceptions apply to very short roads which either have abnormal traffic or have peculiar financial relations with a parent company which is operating it.

The report for 1901-2 shows that the ten greatest railroads of the country, each operating more than 4000 miles of road, spent \$1.167 per train-mile. The average for the whole United States was \$1.1796. It should also be noted that the ratio of total operating expenses to total receipts from operations was 59.78 per cent for the ten roads and 64.66 per cent for the whole United States. To judge of the operating expenses of smaller roads, the figures for No. 10, Table XIV, were taken from the report, the selections being made at random except that the lengths were all less than 100 miles and all of the roads were "operating roads independent".

TABLE XIV

## Operating Expenses

No.	LENGTH (miles)	OPERATING EXPENSES PER TRAIN-MILE	RATIO OF TOTAL OPERATING EXPENSES TO TOTAL RECEIPTS FROM OPERATION (per cent)
1	21.25	\$0.70621	71.62
2	32.60	0.47828	64.21
3	31.00	0.60649	96.12
4	64.10	0.90588	43.41
5	42.00	0.54323	63.07
6	61.00	0.75357	81.05
7	50.00	0.87456	90.32
8	50.39	2.07044	97.58
9	70.78	1.02854	53.46
10	52.20	1.74952	62.15
Average		\$0.97167	72.30
10 longest roads		1.167	59.78
Whole U. S.		1.17960	64.66

A little study of the above figures will show, as might be expected, that local conditions will so affect a very small road that its operating expenses per train-mile may be considerably more or considerably less than the average. The average value for the ten short roads here chosen is less than the average for the United States, and although two of the ten are much greater than the average, it is found that the average value for short roads is a little *less* rather than more.

The reasons for the uniformity are not difficult to understand. Although the gross expense of any one item (such as rail renewals) for a large road is enormously greater than the same item for a small road, the divisor (the number of trains) is correspondingly greater and the quotient, which is the expense for that item per train-mile, is substantially uniform.

*Average Cost of a Train-Mile.* The increase in the average cost of a train-mile is shown in Table XV, which gives the average cost of operating a train 1 mile during 23 consecutive years. The nearly uniform growth of over 73 per cent between 1895 and 1912 is very significant. While predictions of future cost are necessarily guesswork, estimators in railroad economics must make the best possible predictions for five or ten years ahead. There seems to be no

TABLE XV  
Average Cost of Operating a Train 1 Mile

(All roads in U. S.)

YEAR	CENTS	YEAR	CENTS	YEAR	CENTS	YEAR	CENTS
1890	96.006	1896	93.838	1902	117.960	1908	147.340
1891	95.707	1897	92.918	1903	126.604	1909	143.370
1892	96.580	1898	95.635	1904	131.375	1910	148.865
1893	97.272	1899	98.390	1905	132.140	1911	154.338
1894	93.478	1900	107.288	1906	137.060	1912	159.077
1895	91.829	1901	112.292	1907	146.993		

reason to hope for a decrease in the rate or to expect anything else than a continued increase, even though it may prove less rapid than heretofore.

**167. Classification of Operating Expenses.** In Table XVI is shown the classification adopted by the Interstate Commerce Commission—the total cost for each item, each item's per cent part of the total, and the cost in cents per train-mile, which is found by multiplying each percentage by the average cost per train-mile for that year (\$1.59077, or 159.077 cents). While these averages are very instructive in giving a broad view of the subject, they must be used cautiously. For example, the fuel required per mile for locomotives is a very variable quantity, depending on the size of the locomotive and the amount of work done, and it would be very foolish to make any calculations on the basis that the cost of fuel per locomotive-mile would be exactly 16.27 cents.

**168. Maintenance of Way and Structures.** The cost of ties is the largest single item for track material; the cost per train-mile has nearly doubled since 1895. This has been due to a combination, in varying proportions, of three causes—(a) increased cost of ties; (b) lowering of quality to pass inspection, due to growing scarcity; and (c) increase in train load and concentrated wheel load, resulting in more rapid deterioration. There seems to be no chance of decrease in cost in the future unless possibly by more effective preservative processes or by the invention of a metal or a steel-concrete tie which shall be so durable that, in spite of increased first cost, it is cheaper per train-mile.

The cost of roadway and track (item 6) is the labor of track

TABLE XVI

Analysis of Operating Expenses of all Railroads in the United States  
for Year Ending June 30, 1912, Showing Percentage of Each  
Item to Total and Cost in Cents per Train-Mile

ITEM No.	ACCOUNT	TOTAL AMOUNT (thousands)	PER CENT OF TOTAL EXPENSES	CENTS PER TRAIN-MILE
MAINTENANCE OF WAY AND STRUCTURES				
1	Superintendence	\$18,789,	0.990	1.58
2	Ballast	7,157,	0.377	.60
3	Ties	55,463,	2.921	4.65
4	Rails	16,438,	.866	1.38
5	Other track material	17,346,	.914	1.45
6	Roadway and track	129,397,	6.815	10.84
7	Removal of snow, sand, and ice	6,920,	.364	.58
8	Tunnels	1,141,	.060	.10
9	Bridges, trestles, and culverts	27,712,	1.460	2.32
10-12	Crossings, all; fences; snow structures	8,066,	.425	.68
13-15	Signals, telegraph, electrical power transmission	13,681,	.720	1.14
16, 17	Buildings, grounds, docks, wharves	35,389,	1.864	2.96
18	Roadway tools and supplies	4,480,	.236	.38
19	Injuries to persons	1,989,	.105	.17
20, 21	Stationery, printing, and other expenses	1,038,	.054	.09
22, 23	Joint tracks, etc. (net balance)	3,463,	.182	.29
		348,471,	18.353	29.20
MAINTENANCE OF EQUIPMENT				
24	Superintendence	13,175,	.694	1.10
Repairs, renewals, and depreciation:				
25-30	Locomotives, steam and electric	175,889,	9.263	14.74
31-33	Cars, passenger	38,968,	2.052	3.26
34-36	Cars, freight	183,968,	9.690	15.41
37-39	Equipment, electrical, car	318,	.017	.03
40-42	Equipment, floating	1,333,	.071	.11
43-45	Equipment, work	6,128,	.322	.51
46	Equipment, shop(machinery and tools)	10,418,	.548	.87
47	Equipment, power plant	268,	.014	.02
48	Injuries to persons	1,818,	.096	.15
49, 50	Stationery, printing, and other expenses	4,036,	.213	.34
51, 52	Joint equipment, at terminals (net balance)	676,	.036	.06
		436,995,	23.016	36.61
TRAFFIC EXPENSES				
53-60	Agencies; advertising; fast freight lines; etc.	59,047,	3.110	4.95

TABLE XVI (Continued)

Analysis of Operating Expenses of all Railroads in the United States  
for Year Ending June 30, 1912, Showing Percentage of Each  
Item to Total and Cost in Cents per Train-Mile

ITEM No.	ACCOUNT	TOTAL AMOUNT (thousands)	PER CENT OF TOTAL EXPENSES	CENTS PER TRAIN-MILE
TRANSPORTATION EXPENSES				
61, 62	Superintendence and train dispatching	\$40,743,	2.146	3.41
63	Station employes	133,877,	7.051	11.22
64-66	Weighing; car service association; coal and ore docks	15,949,	.839	1.33
67-72	Yards (wages, expenses, supplies)	116,781,	6.151	9.79
73-76	Yard locomotives (fuel, water, lubricants, supplies)	33,658,	1.773	2.82
77, 78	Operating joint tracks, terminals, yards, and facilities (net balance)	10,430,	.550	.88
104, 105				
79, 80	Motormen and road enginemen	120,966,	6.371	10.14
81	Road locomotives, engine-house expenses	33,951,	1.788	2.84
82	Road locomotives, fuel	194,142,	10.225	16.27
83	Road locomotives, water	12,482,	.657	1.04
84, 85	Road locomotives, lubricants, and other supplies	7,430,	.392	.62
86, 87	Operating power plants, purchased power	1,797,	.095	.15
88	Road trainmen	128,339,	6.759	10.75
89	Train supplies and expenses	34,462,	1.815	2.89
90-92	Interlockers, signals, flagmen, draw-bridges	17,831,	.939	1.49
93	Clearing wrecks	5,167,	.272	.43
94-98	Telegraph, floating equipment, stationery, miscellaneous	20,009,	1.054	1.68
99-103	Loss and damage to property, personal injuries	56,838,	2.994	4.76
		984,852,	51.871	82.51
GENERAL EXPENSES				
106-116	Salaries of general officers, clerks, etc.; law, insurance, pensions, miscellaneous	69,297,	3.650	5.81
Total Operating Expenses		\$1,898,662,	100.000	159.08

maintenance. The average daily wages of trackmen have increased almost uniformly from \$1.22 in 1900 to \$1.50 in 1912; the wages of section foremen are quite uniformly about 30 per cent above those of trackmen. The number of trackmen per 100 miles of line has also increased from 118 to 143 in this same period, but there have



been greater fluctuations. The increased number and increased wages have combined to increase very greatly the cost of track maintenance.

**169. Maintenance of Equipment.** The cost of this group of items has been increasing very greatly in recent years, not only in gross amount but also in percentage to total cost of a train-mile and in cents per train-mile. This increased cost is due to higher labor costs in the shops and higher costs for materials. While a change of alinement, involving increase or decrease in length of road, or "distance", will affect these items, the cost is not directly proportional to distance and the same remark applies to many other items. Curvature affects the cost of repairing very greatly—chiefly in wheel wear, and the engineer must consider this in estimating the value of a saving in curvature. The rate of grade also has an effect on this item.

During the first years of the life of a locomotive, the repairs (barring accidents) will be small, but as the locomotive grows older they increase in a growing ratio. When the annual repair charge becomes one-fourth (or in exceptional cases one-third) of its first cost, the locomotive should be sent to the scrap pile, for in such cases the cost per train-mile becomes larger than a reasonable annual charge, allowing for all depreciation, on the cost of a new locomotive. When an old locomotive is replaced by one of a better and more costly type, the *excess* cost should be charged to "betterments", or "permanent additions to equipment".

**170. Transportation Expenses.** There are five items in this group which amount to more than 5 cents per train-mile. The largest is that for fuel. The cost of this (for both yard and road locomotives) has nearly doubled since 1895. This is due partly to increase in cost of coal per ton and partly to the great increase in the power of the average locomotive and therefore in the amount of coal burned per mile. The other four of the five large items are made up almost exclusively of wages, which have increased very greatly in the past twenty years. Any economic calculation, which requires a prediction of the future cost of operation, must include the probability that the cost of conducting transportation will probably not decrease and may increase very materially even during the next five or ten years.

## ECONOMIC LOCATION

**171. General Principles Involved.** A hasty mental review of the previous discussion, as well as a few considerations of common sense, will show the truth of the following statements:

(1) Disregarding the comparatively rare cases in this country where a practicable location of any kind is a creditable engineering feat, it may be said that a comparatively low order of engineering talent will suffice to lay out a line along any general route over which it is physically possible to run trains, and that there are usually several such possible routes. The route selected may not be favorably located for obtaining business, its alinement may be such that its operating expenses are high, and the ruling grades may be so high that only light trains can be run, but the road *can* be operated even with these handicaps.

(2) Among the many possible routes which may be selected for a road, there is one which is superior to any other from an operating or business standpoint, and it is the province and test of the engineer to select that best route.

(3) There are several more or less conflicting interests which must be studied—(a) the maximum of business must be obtained, but this is sometimes only obtainable at great initial cost; (b) the ruling grades must be made as low as possible, which is generally costly, and it *may* require a location which will sacrifice some business; (c) the alinement must be kept easy so as to reduce operating expenses, but this usually is very costly; (d) the total cost must be kept within a figure which will be justified by the future earnings and also leave enough margin as working capital out of the total funds which are raised, so that the road may continue to operate during the five or ten years which are required to build up the “normal” traffic.

(4) Each new route suggested forms a new combination of the above conflicting elements, and the business of the engineer is to estimate and compare these elements, selecting the combination which will give the largest return for the least outlay, considering both initial cost and future operating expenses as elements of the outlay.

**172. Reliability and Value of Economic Calculations.** The student should not form the idea that the following calculations

will enable one to compute with mathematical precision the effect of changes of alinement. There are far too many elements involved, and the effect of certain influences is variable. But although a precise solution is unobtainable, a solution which is sufficiently accurate for practical purposes may be made, and this is infinitely better than no solution at all. For example, suppose that a very crooked stretch of road may be changed to comparatively easy alinement which saves considerable curvature by an additional expenditure of say \$20,000. Assume that it has been computed (by methods developed later) that the operating expenses would be reduced \$3500 per year by the reduction of that curvature. As \$3500 per year, capitalized at 5 per cent, is equivalent to an investment of \$70,000, and as the improvement may be made for \$20,000, the improvement is evidently justifiable. Such is the bare outline of the method.

The estimate of the cost of the improvement may be accurately made, but it is not claimed that the estimate of the saving per year is precise. It may, however, be shown that, even with ample allowances for the uncertain items, it is practicable to assign upper and lower limits between which the truth must lie. A greater knowledge of the subject and greater experience on the part of the engineer will enable him to narrow those limits so that the error is immaterial. And frequently even this is unnecessary. The real question is not whether the capitalized value of the improvement is \$70,000, or \$50,000, or \$90,000. It may be that an improvement which would make possible that saving may be made for a few thousand dollars, or it might require \$200,000. In either case, the true answer is unquestionable.

If the cost of the improvement is very nearly equal to its computed capitalized value, then no great harm can come from either decision, for the decision would then be based on the willingness of the company to spend additional money. The method furnishes a criterion, which even in the hands of an inexperienced engineer has some value, and which alone gives value to his opinion. But the method enables the experienced engineer to give the best opinion which is obtainable, for it enables him to apply his experience to a method of computation which approaches accuracy as nearly as may be.

It must not be supposed that the numerical values worked out in the following pages are necessarily applicable to any assumed case. They are given to show the *method* of their derivation, and should be modified to fit local conditions according to the best judgment of the engineer.

## DISTANCE

**173. Relation of Distance to Rates and Expenses.** Rates are usually based on distance traveled on the apparent assumption that the value of the service rendered and the cost to the company are directly proportional to the number of miles traveled. The assumption in either connection is not true. If a passenger or a load of freight is to be transported from one city to another city 100 miles away, the service rendered is to accomplish the transfer as easily and quickly as possible. If another road were constructed, perhaps at extravagant cost, by which the distance were cut down to 90 miles, that road would render a greater and better service, because it would reduce the necessary travel, and yet on the mileage basis the shorter road would be entitled to less than the other in spite of the fact that it renders a better service.

The assumption that the cost is proportional to the distance is more nearly correct, although, as will be shown later, even this is far from accurate. It is not difficult to compute an average cost for a large number of passenger trains and, by dividing it by the total passenger mileage, to obtain a value of the cost of a "passenger-mile". But the additional cost of transporting one additional passenger on a regular train is hardly more than the cost of printing his ticket. Even if it were practicable to compute the extra consumption of coal and the infinitesimal addition to other operating expenses due to his being on the train, the added cost would evidently be but an insignificant fraction of the average cost of a passenger-train-mile. The same argument holds, but not to the same extent, if we consider the additional cost of an extra ton of freight.

By the same line of argument it will be shown that a change in distance will not affect the cost of running trains in proportion to the change. It is easy to see that general expenses will be absolutely unaffected by an alteration of alinement which saves a mile

in distance, and it will be shown that even the consumption of fuel does not vary in proportion to the distance. If it were practicable to construct a tariff of rates which should consider excessive curvature and grades on the various parts of the line and make the rates dependent on them as well as on many other constructive features which add to the cost of operation, the rates would be more nearly proportional to the cost, but the public would not appreciate it and it would be useless work. And when it is further shown that it is sometimes justifiable for a road to haul competitive business at a rate actually less than the average cost of their traffic, it will be seen that the relation of distance to rates and expenses cannot be expressed by any simple proportion.

**174. Effect on Receipts.** Among all the details of alinement, distance is the one for which there is some compensation in an increase, and that is because rates are based on distance rather than on curvature or grades. Although it is unquestionably contrary to public policy to burden traffic unnecessarily by an increase in distance, yet it may be demonstrated that the added receipts from non-competitive traffic due to such increased distance will amount to more than their added cost. But in order to study this feature properly the distinction between competitive and non-competitive rates must be noted. For our purposes traffic may be classified as "through" and as "local", in which through traffic refers to that which passes over *two or more roads*, no matter how long or short any section of the trip may be, and in which local traffic refers to that which is confined to *one railroad system*, though it may run from one end to the other. Further subdivision is necessary as follows:

(1) *Non-competitive local*—on one road with no choice of routes.

(2) *Non-competitive through*—on two (or more) roads but with no choice.

(3) *Competitive local*—a choice of two or more routes, but the entire run may be made on the home road.

(4) *Competitive through*—direct competition between two or more routes, each passing over two or more lines.

(5) *Semi-competitive through*—a non-competitive haul on the home road and a competitive haul on foreign roads.

Receipts for traffic passing over two or more lines are divided between the lines in proportion to mileage. "Terminal charges" are sometimes subtracted from the amount before the division is made and sometimes a strong road forces a weaker road to submit to some other exaction before the division is made, but the final division is made in proportion to the mileage for each passenger ticket or each freight bill. It may be shown that the cost of operating an additional mile is about 58 per cent of the average cost. This means that on all non-competitive business (class 1) there is an actual profit in this added distance. On the other hand, competitive rates are made with small regard to distance, are generally equal, and therefore any added distance results in a sheer loss without any compensation. This applies to all the traffic of class 3.

*Illustrative Example.* The other classes of traffic are affected by distance in various degrees between these two extremes. Suppose that the distance on the home road for any given shipment is 100 miles, and the distance on the foreign road for that shipment is 150 miles; suppose that the freight charge is \$10; then the home road will

receive  $\frac{100}{100+150} \times \$10 = \$4.00$ . This means 4 cents per mile for

that particular class and weight of freight. Suppose that the distance is increased 5 miles on the home road, but assume that the traffic is wholly competitive and therefore that the total rate received will be \$10, regardless of the added distance. Then the

home road will receive  $\frac{105}{105+150} \times \$10 = \$4.1176$ . If we allow to

the original 100 miles its full previous allowance of 4 cents per mile, we have left 11.76 cents to pay for the extra 5 miles. This is at the rate of 2.352 cents per mile, which is 58.8 per cent of the 4-cent rate.

This nearly equals the computed percentage of added cost for additional distance computed in miles. Therefore, if the original 4-cent rate is profitable, the added receipts due to the added distance will be sufficient to operate the added distance profitably, or without loss. Incidentally, the foreign road suffers, for it will receive less for precisely the same service. The above numerical case is very nearly at the dividing line between profitable and unprofitable addition to distance. If the length of the home road

is but a small proportion of the total distance, then it may be similarly computed that an addition to distance is distinctly profitable. On the other hand, if the length of the home road is a large proportion of the total distance, an addition to distance is distinctly unprofitable, and when the length of the foreign road is zero (which means that the competitive haul is entirely on the home road) then any addition to distance is sheer loss without any compensation, even partial.

The above numerical case represents but one of an almost infinite number. Each station along the line has possible traffic connection with almost every other railroad station in the country. The route from each station to every other station represents a new combination, and the net effect of the added distance is the combined effect of all the separate cases. This instantly shows that a precise mathematical solution is impossible, but the above solution has value in pointing out some general truths as follows:

In *all* non-competitive business, whether through or local, the added receipts due to added distance will be profitable, and if the business of a road is almost entirely non-competitive there is little or no disadvantage in added distance, especially if the construction is cheapened in spite of the added distance. For example, a road which follows the banks of a very crooked river may cost less to build, even though much longer and more crooked, than the road which tunnels through the horseshoe bends.

When roads handle a very large amount of competitive business any additional distance may be a source of loss on that class of business, and the loss may be so serious as to justify a considerable expenditure to reduce it. Another reason for the subsequent expenditure of money to reduce distance is that, after freight rates are once established between roads on through business, they are not apt to be disturbed to make them conform to the slight fluctuations of distance caused by changes in the alinement.

The above statements can be reduced to the general conclusion that since every road handles a considerable proportion of non-competitive business, there is always some compensation for the added expenses of operating additional distance. The majority of small roads do a business which is almost wholly non-competitive, and to them the added receipts will usually pay for the added dis-

tance, even if it is not an actual source of profit. Finally, it may be said that a road is not usually justified in making an additional expenditure to shorten distance (i.e., adopt a route which will have a greater gross cost in spite of the shortened distance) unless it handles a very large amount of highly competitive business.

There are some other considerations which must not be ignored in considering this question. One of them is the question of the additional time required to make the trip. This may be important in two ways. (1) The competition for passenger business between two cities, such as New York and Philadelphia, or Philadelphia and Atlantic City, might be so keen that a difference in length of line which would affect the running time by even 10 minutes would have great financial importance. (2) A very considerable change in distance may have a serious effect on the operation of the heavy through-freight trains, although it would not ordinarily increase the total cost of operating those trains over that division more than the extra number of train-miles times the reduced train-mile cost. But in any case, this phase of the question should not be ignored.

Another consideration is the possible effect on the business done. "A short straight line" is the popular description of a well-designed road. If the engineer's aim for a *short* road leads him to pass by sources of income and thus lose them, his road will have little business and the receipts will be reduced because it is short. As a general rule "adopt that route which will give the greatest traffic per mile of road". On the one hand, this avoids the error of running a line which is excessively crooked in the effort to secure every possible element of traffic and thus burdening the whole traffic with an excessive haul, and on the other hand, avoids running a line which misses important sources of traffic in the effort to have a straight line.

## CURVATURE

**175. Operating Disadvantages of Curvature.** The non-technical mind appreciates, even too readily, the disadvantages of curvature. But it is generally true that the ones which are most thoroughly appreciated by the public are of least economic value to the engineer. The several disadvantages will be classified



and discussed in an order which is perhaps the inverse order of their importance, as follows:

(1) It increases the danger of collision and derailment and aggravates the damages of a derailment when it occurs. The application to be made to this statement of undoubted fact is—how much is a road justified in expending in order to reduce or eliminate any given curve? Since the entire elimination of curves is a physical as well as a financial impossibility, the question reduces to the lessening of danger from accidents that would result from such reductions as are possible. The Interstate Commerce Commission report on railroad accidents for the year ending June 30, 1902, showed that the number of passengers carried 1 mile for one killed was 57,022,283. This means that the chances are even that a passenger could ride 57,000,000 miles before he would be killed. If he were to ride continuously at the rate of 60 miles per hour, it would require over 9,500,000 hours, or nearly 400,000 days, which is considerably over 1000 years.

But how many of such casualties are due to curvature, and how many million miles must be traveled by the average passenger before, according to the law of probabilities, he would be killed by an accident which should not only be directly charged to curvature, but also to curvature which is physically or financially avoidable. If we estimate the number of curves on all the railroads of the country as 250,000, what is the probability of a fatal accident happening on any one curve and how much may be spent on that curve to reduce the danger? Even if it were spent, would there remain *no* danger of an accident there? A thorough logical analysis of this question shows that although it is always proper to take reasonable precautions to avoid accident at an especially dangerous curve (such as maintaining a flagman there), it is impossible to assign any financial value to the mere *danger* of accident which would accomplish anything toward modifying construction.

(2) Curvature may affect traffic (a) by reducing the possible speed of fast trains. There is some force to this objection as it applies to sharply competitive traffic between two cities—a traffic of which most roads have not a trace. The extent to which the passenger traffic might be increased by the minute or two which might be saved is, however, so uncertain that it defies analysis.

(b) It may produce rough riding, and (c) it may create an apprehension of danger which may of itself deter travel. The disadvantages resulting from all three of these sub-causes are greatly reduced by good roadbeds and transition curves. Freight traffic, which comprises about two-thirds of the total, is unaffected by it unless the curvature is extreme, and the passenger traffic of most roads will not be influenced by it; and therefore an engineer is not ordinarily justified in giving it any financial weight.

(3) It *may* affect the operation of trains (a) by limiting their length and (b) by limiting the type and weight of engines. There are a few instances known where roads which run along a river bank have very easy ruling grades and on which the curvature is perhaps very sharp on account of sharp bends in the river. On such roads the curvature may be the feature which limits the length of trains, but such cases are rare and even when they occur a computation similar to that later developed will show how much may profitably be spent to reduce the rate of curvature. If a long grade up a mountain were kept uniform, regardless of curves, the curves would add such resistance that they would limit the length of trains, but good practice requires that the grades shall be "compensated for curvature", as explained later.

The excessively sharp curvature which has been used on some mountain roads may preclude the use of some of the largest types of locomotives. But such roads ordinarily do not have a traffic which justifies the use of the heaviest locomotives. And when it is considered that a Mallet locomotive, having sixteen drivers and a weight on the drivers of over 400,000 pounds, can be operated on a 20-degree curve, any limitation in the use of engines may be ignored for all ordinary railroad work.

(4) Curvature increases operating expenses. This disadvantage is definite, positive, and approximately computable, and since a reduction in expenses may be made by reducing curvature, we must calculate the effect of curvature on operating expenses.

**176. Compensation for Curvature.** Curvature makes a very definite increase in train resistance, and such increased resistance is readily equated to its equivalent in added grade. Assuming that the curve resistance on a 6-degree curve is 4 pounds per ton, which is the grade resistance of a 0.2-per-cent grade, if there should be

a 6-degree curve on a 1.0-per-cent grade, the resistance on that grade would be the same as on a straight track having a 1.2-per-cent grade. On this basis, if 1.2 per cent were selected as the ruling grade and it became necessary to introduce a 6-degree curve, the grade should be reduced on that curve to 1 per cent so that the total resistance on that curve shall be no greater than on the tangent. This is the fundamental idea of curve compensation. On grades which are so low that they will never be ruling grades even if the rate of ruling grade is reduced by reconstruction, there is no necessity for curve compensation, but the neglect of it on ruling grades means that the ruling grade is practically increased to the grade which is the equivalent of the combined grade and curve resistance.

*Rate of Compensation.* This term means such a reduction in the grade that the saving in grade resistance equals the curve resistance. But curve resistance varies somewhat as the velocity, the condition of the rails, and even the type of the wheel base. For simplicity of calculation the curve resistance is usually assumed to vary as the degree of curvature. While this is nearly true for low degrees of curvature, it becomes grossly inaccurate for excessively sharp curvature, on which the resistance is fortunately much less than its proportionate amount. This is probably due to the fact that a large part of the resistance from curvature is due to causes which are independent of the degree of curve. The resistance will amount to about 2 pounds per ton per degree of curve (equivalent to a 0.1-per-cent grade) when the velocity is very low—as when starting a train. It is less for fast trains than for slow trains, but considering that it is the slow and heavy freight trains which must be chiefly considered, the larger values for compensation which are needed for the slower velocities must be used. Compensation results in a loss of elevation for a given horizontal distance and when money has been spent in “development” in order to reduce the grade to some desired limit, any useless compensation is a waste and should be avoided. If a curve occurs on a grade immediately below a stopping place for *all* trains (or at least all trains which are so heavy that they will be affected by the ruling grade), the compensation may be reduced or omitted altogether on the ground that the curve resistance would simply use up the energy which might otherwise be used up by brakes in stopping the train. If

that heavy grade should continue on above that stopping place, then the compensation should be made even greater than the average to allow for the increased resistance while starting. Since the curve resistance merely adds to the virtual grade, and the object of compensation is to prevent such additions from increasing the ruling grade, there is no object in using compensation on a grade, which is already so low that the added resistance will not make it virtually equal to the ruling grade. An exception to this lies in the danger that it may some time prove desirable to make such changes of alinement that the ruling grade is very materially cut down, and it might happen that neglect to compensate would add that much to the revised ruling grade. The above discussion may therefore be reduced to the following rules:

(1) On the upper side of a stopping place for all heavy trains compensate 0.10 per cent per degree of curve.

(2) On the lower side of such a stopping place do not compensate at all—but this rule should be applied cautiously.

(3) Ordinarily compensate about 0.035 per cent per degree of curve.

(4) Increase this rate to 0.04 per cent when the curve is habitually operated at slow speed, or when the super-elevation is excessive for freight trains, unless it is found that the higher rate of compensation causes such a loss of height that the grade on the tangent must be increased.

(5) Curves which are so much less than the ruling grade, that they will *always* be minor grades need not be compensated, but the possibilities of a future reduction in the rate of ruling grade should be considered.

**177. Limitations of Curvature.** Surveys for railroads are frequently made under instructions that curves (and also grades) shall not exceed some chosen limitations. What should be the limitation, if any, of the degree of curvature? Probably no definite answer is correct unless it be said that there should be no limitation. It has been shown that all ordinary degrees of curvature even up to 20 degrees will still permit the use of heavy engines, and there are numerous instances where a heavy railroad traffic has been hauled for many years around excessively sharp curves without any serious difficulty—as, for instance, the traffic on the Baltimore & Ohio

Railroad at Harper's Ferry, which for many years was hauled around a 19-degree 10-minute curve (radius 300 feet). This curve was changed some years ago. Of course the young engineer should not conclude from this that curvature is of no consequence, and that he may recklessly put in as much and as sharp curvature as might seem at first the easiest plan to adopt. It may be shown that there is a definite money value in reducing every possible degree of central angle and also that the radius of curvature should be made as large as possible without a serious sacrifice of other interests or extravagant expenditure. It generally happens, when running a road through a mountainous country, and when a high summit must be crossed, that the grades can only be reduced by the adoption of very sharp curvature or by a large expenditure in construction. Since the expenditure is usually limited by financial considerations, the error of adopting a high ruling grade is usually made and the degree of curvature is limited to a low figure which is ridiculously out of proportion to the general condition of the road.

Sometimes the limited money at the disposal of the company is wasted on a route which gives easy curves when the money could have been spent advantageously in other ways. The most common error is the needless increase in the ruling grade. Many railroads have been laid out under the instructions that the maximum grade may be 60 feet per mile and the minimum curve 6 degrees. These limits have been used separately, or in combination, with the result that when a 6-degree curve occurred on a 60-foot grade, the virtual grade was thereby increased (on a 0.035-per-cent basis) to over 71 feet per mile. While a grade of 60 feet per mile might be a very proper ruling grade under certain conditions, it might readily happen that the option of using a 10-degree curve (properly compensated) would permit adopting a line with a ruling grade so much less than 60 feet that the advantages of the reduction of grade would far outweigh the comparatively insignificant disadvantages of the sharp curvature. Therefore, as a general answer it may be said that the limits, if any, should conform to the general character of the country, and that when it appears possible to obtain a great advantage, such as the reduction of the ruling grade, by an increase in the degree of curvature and even in the degrees of central angle, such increase should be made unless it may be definitely computed

that the disadvantages of the increased curvature would outweigh the advantages of the reduced grade.

### GRADE

**178. Distinction between Minor and Ruling Grades.** The distinction between minor and ruling grades must be very clearly understood before their operating disadvantages may be computed. The cost of running a train one mile is largely independent of whether the train is long or short, heavy or light. The receipts for transporting so many tons of freight is a definite quantity and is unaffected whether it is transported in one train load or two. If it is possible by a reduction in grade to haul in a single train load as much freight as would require two train loads by the old plan, then, since the receipts are constant and the cost of the two light trains will be nearly double that of the one heavy train, it is evident that the low-grade plan will be very profitable and the other plan correspondingly costly and financially ruinous.

Although it is not often practicable to double the weight of the train behind a freight engine, a very material increase in the train load can generally be made by such reduction of the ruling grade as is practicable, and such increase in train load frequently makes all the difference between large dividends and an actual deficit. The ruling grade definitely limits the load that can be hauled by an engine with a given weight on the drivers and its financial effect is very great. On the other hand, a minor grade does not limit the number of cars and its effect on operating expenses is confined chiefly to an increase in the consumption of fuel and other locomotive supplies. While this increase in expense has an importance which is worth computing, it is insignificant compared with the cost of running additional trains to handle a given traffic.

The real cost of minor grades is also less than it might otherwise be considered owing to the fact that each rise has its corresponding fall. Even though several high summits may be crossed, the difference in elevation of the terminals, say 200 feet, or even 500 feet, is insignificant from the standpoint of grade when the distance is perhaps as many miles. And even in the extreme case when the grade is all in one direction, the additional energy required to climb the grades is partly returned in the assistance the grade

gives to trains on the return trip and the consequent saving in motive power.

**179. Laws of Accelerated Motion.** *Application to Movement of Trains.* When a train starts from rest and acquires its normal velocity, say 30 miles per hour, the engine must develop not only the power required for all the ordinary tangent and perhaps curve and grade resistances, but also the "kinetic energy" corresponding to the velocity which has been acquired. This kinetic energy is not wasted; all of it is transformed back into work of some kind. The energy may be consumed and wasted in the brakes, but it may also be spent (and is so spent) in overcoming resistances whenever the velocity of the train is reduced. The amount of this kinetic energy is a definite mathematical quantity. The laws of Mechanics tell us that this energy equals  $W (v^2 \div 2g)$ , in which  $W$  is the weight of the train,  $v$  is its velocity in feet per second, and  $g$  is the acceleration of the force of gravity, which equals 32.16 feet per second in a second.

A better appreciation of this force may be obtained by considering for a moment that if the train could move along the track without any resistance, then, when running at a velocity of  $v$  feet per second, it possesses a kinetic energy which would raise it to a height of  $h$  feet, where  $h = v^2 \div 2g$ . If we consider that the engine is furnishing exactly the power required to overcome the tractive resistances, then the train would run until it had climbed a grade to a height of  $h$  feet, no matter whether it was accomplished in 100 feet, or a mile. By an expansion of the theory it is also shown that when the train has climbed a vertical height of  $h'$  feet (less than  $h$ ), it will have left a velocity  $v' = \sqrt{2g (h - h')}$ .

*Illustrative Example.* Assume that the velocity of a train is 30 miles per hour, or 44 feet per second. It then has a kinetic energy which would raise it a height  $h = \frac{44^2}{2 \times 32.16} = 30.1$  feet. If the engine furnished just enough energy to overcome the tractive resistances, the kinetic energy would carry the train up a grade of 15 feet per mile for a distance of about 2 miles, or up a grade of 60 feet per mile for a distance of about  $\frac{1}{2}$  mile. If the train were moving up a grade of 20 feet per mile and had proceeded half a mile, it would have climbed 10 feet and would still have a kinetic

energy corresponding to 20.1 feet, and its velocity would then be  $v' = \sqrt{2 \times 32.16 \times 20.1} = 35.9$  feet per second, or 24.5 miles per hour.

If the train were a solid mass the above figures would be absolutely correct, but the solution is a little complicated by the fact that an appreciable part of the weight of the train consists of revolving wheels, to which must be imparted the kinetic energy of rotation, in addition to the kinetic energy of translation. The ratio of this rotative kinetic energy to that of translation depends chiefly on the ratio of the weights of the wheels and of the whole car or engine. Evidently this ratio depends on the detailed design of the rolling stock, and more especially on whether the cars are loaded or empty. This consideration shows that no one value will be accurate for all cases, but there will be little error in adopting 5 per cent as an average value for the increase in the kinetic energy.

Table XVII, which will be found very useful in these computations, has therefore been compiled on the following basis:

$$\begin{aligned} \text{"Velocity head"} &= \frac{v^2 \text{ in ft. per sec.}}{2 \times 32.16} = \frac{1.4667 V^2 \text{ in m. per h.}}{64.32} \\ &= 0.03344 V^2 \end{aligned}$$

$$\begin{aligned} \text{and, adding 5 per cent for rotative} \\ \text{kinetic energy of the wheels,} &= 0.00167 V^2 \\ \text{Therefore, corrected velocity head} &= 0.03511 V^2 \end{aligned}$$

Part of the figures of Table XVII were obtained by interpolation, and, therefore, there may be an error of a single unit in the hundredths place in some of the figures, but considering the uncertainties in the problem, the exact value to hundredths is of no practical importance. Examples of the application of this table will be given later.

The tractive force required to produce this acceleration in a given distance may be stated as

$$P = \frac{W}{2gs} (v_2^2 - v_1^2)$$

in which  $v_1$  and  $v_2$  are the lower and higher velocities in feet per second,  $s$  is the distance in feet,  $g$  is the acceleration of gravity (32.16), and  $W$  is the weight in pounds. If we substitute  $W = 2000$  (or one ton),  $g = 32.16$ ,  $v_1 = V_1 \frac{5280}{3600}$ , and  $v_2 = V_2 \frac{5280}{3600}$ , to reduce the



**TABLE XVII**  
**Velocity Head (Proportional to Kinetic Energy) of Trains**  
**Moving at Various Velocities**

VELOCITY (miles per hour) V	* VELOCITY HEAD $V^2 \times 0.03511$									
	0.0	0.1	0.2	0.3	0.4	0.5	0.6	0.7	0.8	0.9
5	0.88	0.91	0.95	0.99	1.02	1.06	1.10	1.14	1.18	1.22
6	1.26	1.31	1.35	1.40	1.44	1.48	1.53	1.58	1.62	1.67
7	1.72	1.77	1.82	1.87	1.92	1.97	2.03	2.08	2.14	2.19
8	2.25	2.30	2.36	2.42	2.48	2.54	2.60	2.66	2.72	2.78
9	2.85	2.91	2.97	3.04	3.10	3.17	3.24	3.30	3.37	3.44
10	3.51	3.58	3.65	3.72	3.79	3.87	3.95	4.02	4.10	4.17
11	4.25	4.33	4.41	4.49	4.57	4.65	4.73	4.81	4.89	4.97
12	5.06	5.15	5.23	5.32	5.41	5.50	5.58	5.67	5.75	5.84
13	5.93	6.02	6.12	6.21	6.31	6.40	6.50	6.59	6.69	6.78
14	6.88	6.98	7.08	7.19	7.29	7.39	7.49	7.60	7.70	7.80
15	7.90	8.00	8.11	8.22	8.33	8.44	8.55	8.66	8.77	8.88
16	8.99	9.10	9.21	9.32	9.43	9.55	9.67	9.79	9.91	10.03
17	10.15	10.27	10.39	10.51	10.63	10.75	10.87	10.99	11.12	11.25
18	11.38	11.50	11.63	11.76	11.89	12.02	12.15	12.28	12.41	12.55
19	12.68	12.81	12.95	13.08	13.22	13.35	13.49	13.63	13.77	13.91
20	14.05	14.19	14.33	14.47	14.61	14.75	14.89	15.04	15.19	15.34
21	15.49	15.64	15.79	15.94	16.09	16.24	16.39	16.54	16.69	16.84
22	17.00	17.15	17.30	17.46	17.62	17.78	17.94	18.10	18.26	18.42
23	18.58	18.74	18.90	19.06	19.22	19.38	19.55	19.72	19.89	20.06
24	20.23	20.40	20.57	20.74	20.91	21.08	21.25	21.42	21.59	21.77
25	21.95	22.12	22.30	22.48	22.66	22.84	23.02	23.20	23.38	23.56
26	23.74	23.92	24.10	24.28	24.46	24.65	24.84	25.03	25.22	25.41
27	25.60	25.79	25.98	26.17	26.36	26.55	26.74	26.93	27.13	27.33
28	27.53	27.73	27.93	28.13	28.33	28.53	28.73	28.93	29.13	29.33
29	29.53	29.73	29.93	30.13	30.34	30.55	30.76	30.97	31.18	31.39
30	31.60	31.81	32.02	32.23	32.44	32.65	32.86	33.08	33.30	33.52
31	33.74	33.96	34.18	34.40	34.62	34.84	35.06	35.28	35.50	35.72
32	35.95	36.17	36.39	36.62	36.85	37.08	37.31	37.54	37.77	38.00
33	38.23	38.46	38.69	38.92	39.15	39.38	39.62	39.86	40.10	40.34
34	40.58	40.82	41.06	41.30	41.54	41.78	42.02	42.26	42.51	42.76
35	43.01	43.26	43.51	43.76	44.01	44.26	44.51	44.76	45.01	45.26
36	45.51	45.76	46.01	46.26	46.52	46.78	47.04	47.30	47.56	47.82
37	48.08	48.34	48.60	48.86	49.12	49.38	49.64	49.91	50.18	50.45
38	50.72	50.99	51.26	51.53	51.80	52.07	52.34	52.61	52.88	53.15
39	53.42	53.69	53.96	54.23	54.51	54.79	55.07	55.35	55.63	55.91
40	56.19	56.47	56.75	57.03	57.31	57.59	57.87	58.16	58.45	58.74
41	59.03	59.32	59.61	59.90	60.19	60.48	60.77	61.06	61.35	61.64
42	61.94	62.23	62.52	62.82	63.12	63.42	63.72	64.02	64.32	64.62
43	64.92	65.22	65.52	65.82	66.12	66.43	66.74	67.05	67.36	67.67
44	67.98	68.29	68.60	68.91	69.22	69.53	69.84	70.15	70.46	70.78

velocities  $v_1$  and  $v_2$  (which are in feet per second) to  $V_1$  and  $V_2$ , the velocities in miles per hour, the equation becomes

$$P = \frac{2000}{2 \times 32.16s} \left( \frac{5280}{3600} \right)^2 (V_2^2 - V_1^2) = \frac{66.89}{s} (V_2^2 - V_1^2)$$

Adding 5 per cent for the kinetic energy of rotation, the coefficient 66.89 becomes 70.23, but, considering that the 5 per cent correction is somewhat approximate and variable, the coefficient is taken at the even figure of 70 and the equation becomes

$$P = \frac{70}{s} (V_2^2 - V_1^2) \quad (104)$$

in which  $P$  is the force in pounds per ton to accelerate a train from a velocity of  $V_1$  miles per hour to  $V_2$  miles per hour in a distance of  $s$  feet. Conversely,  $P$  is the force in pounds per ton which can be utilized in overcoming tractive or grade resistance when the velocity is reduced from  $V_2$  m.p.h. to  $V_1$  m.p.h. in a distance of  $s$  feet.

**180. Virtual Profile.** The following demonstrations are made on the basis that the ordinary tractive resistances and also the tractive force of the locomotive are independent of velocity. Neither of these assumptions is strictly true, especially the latter. The variation of tractive power with velocity will be considered later (article 191). But the approximate results obtained on the basis of these two assumptions are so instructive and useful that the demonstration is given. Assume that Fig. 157 shows the profile of a section of road and that the grade of  $A E$  is 0.40 per cent, which is 21.12 feet per mile. Assume also that a freight engine which is climbing up the grade has been so loaded that when the engine is working *uniformly* at its normal maximum the velocity up such a grade would be uniformly 20 miles per hour. But since the train is moving at 20 miles per hour it has a kinetic energy corresponding to a velocity of 14.05 feet (see Table XVII). At  $A$  it encounters a downgrade of 0.20 per cent, which is 1500 feet long. Although  $A B$  has a downgrade of only 0.2 per cent, its grade with respect to the upgrade of  $A E$  (0.40 per cent) is 0.60 per cent. Therefore  $B$  is 9.00 feet below  $B'$ . Since the work done by the engine would have carried the train up to the point  $B'$  with a velocity of 20 miles per hour, the *virtual* drop of 9 feet will increase the

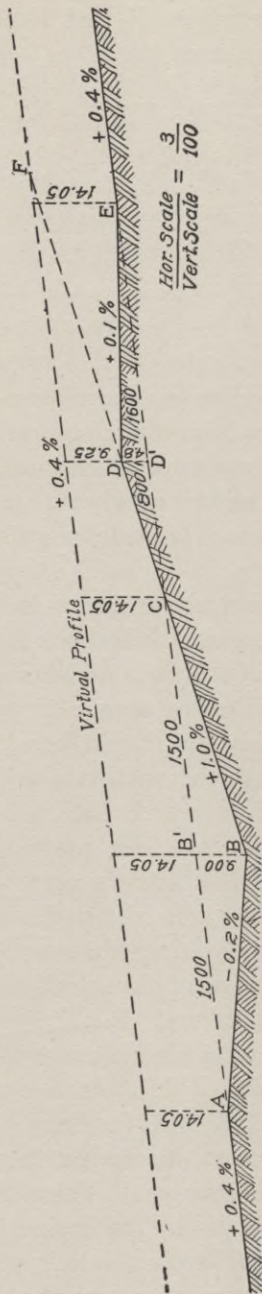

Fig. 157. Typical Profile of Road Section

velocity head from 14.05 feet to 23.05 feet, which corresponds to the velocity of 25.6 miles per hour, and this will actually be the velocity of the train at the point *B*. At *B* the grade changes to a 1.0-per-cent upgrade for a distance of 2300 feet.

The approach of the grade *BC* to the grade *B'C* is at the rate of 1.0–0.4, or 0.6 per cent and therefore the point *C* will be reached in 1500 feet. In the remaining 800 feet the line will climb to *D*, which is 4.8 feet above *D'*. Although at *B* the train is moving at the rate of 25.6 miles per hour and the engine is working at such a rate that it will carry the train up a 0.4-per-cent grade, yet when climbing up a 1.0-per-cent grade it consumes its kinetic energy in overcoming the additional grade. When it reaches *C*, it has lost the additional kinetic energy which it gained from *A* to *B*, and as it continues it loses even more. When it reaches *D*, it has lost 4.8 feet more and its velocity head is reduced to  $14.05 - 4.8 = 9.25$  feet, which corresponds to a velocity of 16.2 miles per hour. At *D* the grade changes to +0.1 per cent.

Here we have the rather surprising condition that, although the grade is actually rising, it is virtually a downgrade under the given conditions, for the engine is working harder than is required to run up merely a 0.1-per-cent grade and hence will gain in velocity. At *E*, a distance of 1600 feet from *D*, it reaches what would have been a uniform 0.4-per-

cent grade from  $A$  to  $E$  and the grade continues at that rate. Although the train has actually climbed 1.6 feet from  $D$  to  $E$ , it has virtually fallen the 4.8 feet between  $D$  and  $D'$ , and the velocity head has increased from its value of 9.25 feet at  $D$  to 14.05 feet, and its velocity is again 20 miles per hour. The upper line represents the "virtual profile", which may always be drawn by measuring off to the proper scale at every point an ordinate which is the velocity head at that point. Since the engine is working uniformly, the virtual profile is in this case a straight line.

Although the variation of resistance and tractive effort with velocity will have some effect on the precision of the above figures, as discussed later, yet the demonstration must not be considered as fanciful and impractical. *Under the given conditions* it is substantially what would take place. If the grade  $BD$  were continued to  $F$ , or until the actual grade intersected the virtual profile, the train would become stalled, for when the engine is loaded for an indefinite haul up a 0.4-per-cent grade, it cannot haul a train indefinitely up a higher grade. Practically the train would stall somewhat short of  $F$ , since the tractive resistance increases as the velocity drops to nearly zero. Under such conditions,  $BD$  is a "momentum grade", which *may be* higher than the ruling grade, and yet it is practically harmless under these conditions, *provided* that a train is never required to stop on that grade.  $ABC$  is technically a "sag" in the grade  $AC$  and would be considered such even if  $AB$  were an upgrade (although less than the grade  $AC$ ). Such a sag is usually harmless unless it is so deep that the train would acquire a dangerously high velocity at the bottom of the sag  $B$ .

In the above numerical case the velocity is only 25.6 miles per hour, which is not at all dangerous even for freight trains in these days of air brakes and automatic couplers. But a much deeper sag might require the use of brakes, which not only consumes some of the energy stored in the train, but also wears out the wheel treads and brake shoes.

Another phase of the question is developed when we consider the action of a train stopping on a grade. Assume, as in Fig. 158, that a train is climbing up the grade  $AB$  at a uniform velocity whose velocity head is measured by  $AA' = BB'$ . At  $B$  it commences to slow up for a stop at  $C$ . Since it is stationary at  $C$ , the

velocity head is zero and the virtual profile  $A'B'$  runs from  $B'$  to  $C$  by a line which may or may not be straight. Assume that the train starts up and the engine exerts such force that at  $D$  it has regained the velocity it had at  $A$  or  $B$ . The ordinate  $DD'$  must equal  $AA'$  and the virtual profile must run from  $C$  to  $D'$ .  $CD'$  therefore represents the virtual grade up which the train must climb. To put it in figures: Assume that  $CD=1300$  feet; the required velocity at  $D$  is 20 miles per hour, and therefore  $DD'=14.05$ ; the grade of  $CD$  is 1.0 per cent and therefore  $DD''=13$  feet, and  $D''D'=27.05$  feet; the virtual grade  $CD'$  is therefore 2.08 per cent instead of the actual 1.0 per cent and these figures represent the actual ratio of the drawbar pulls at the engine.

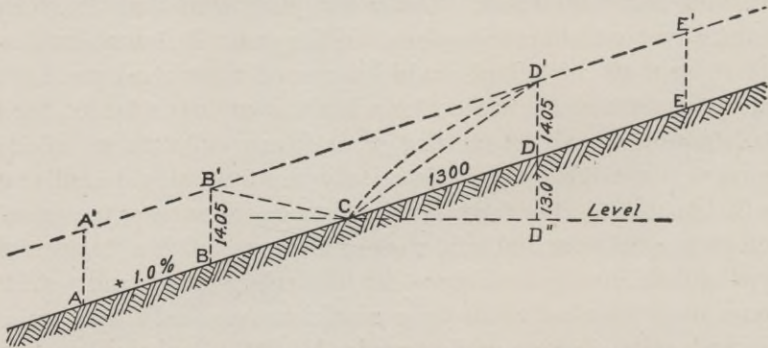

Fig. 158. Diagram Showing Action of Forces on Train Stopping on Grade

To be more precise, the virtual grade  $CD'$  will not be a uniform grade as shown in the figure but will be a curved line which will be steeper at the beginning of the grade on account of the increased resistance to traction when starting. This is somewhat compensated by the fact that the tractive force of the engine is greater at the very low velocities. It requires, however, a little margin for safety.

The fact that the engine can increase its velocity from zero to 20 miles per hour in that distance and on that grade shows that it is capable of doing much more than run its train up the 1.0-per cent grade at a speed of 20 miles per hour. In fact, unless the power is reduced when the train reaches  $D$ , the train will continue to gain velocity. If resistance and tractive power were independent of velocity, the train would continue to gain indefinitely, assuming

that the grade continued uniformly. But practically, when the velocity had increased to a much higher figure, the resistances would increase and the tractive power decrease until there could be no further increase in velocity.

From all the above it may be inferred that

(1) When the velocity is uniform, the virtual profile is parallel with the actual profile.

(2) When the velocity is increasing, the profiles are separating; when it is decreasing, they are approaching each other.

(3) When the velocity is zero the profiles coincide.

(4) The virtual grade at any place is a measure of the work required of the engine beyond that required to overcome merely the tractive resistances. If it is horizontal it shows that the engine is doing nothing besides overcoming the tractive resistances. If it is upward and is uniform, as in Fig. 157, it shows that it is working uniformly and is storing in the train "potential" energy which may be utilized on the return trip if it is not utilized in moving down a succeeding downgrade. If it is downward, as from  $B'$  to  $C$ , Fig. 158, it shows that the train is giving up kinetic energy, probably consuming most of it in brakes, but utilizing some of it to furnish the tractive power to run from  $B$  to  $C$  and also to overcome the grade from  $B$  to  $C$ .

#### 181. Use, Value, and Possible Misuse of Virtual Profiles.

It has been previously shown that, aside from securing the maximum traffic, the most important accomplishment for the locating engineer is to obtain low ruling grades. At the same time the cost for grading must be kept as low as possible without sacrificing the more important elements. The grade  $BD$  in Fig. 157 is an example of the possibility of introducing a grade which is much steeper than the ruling grade, providing it is not so long that the kinetic energy of the train at the bottom of the grade is exhausted before it reaches an easier grade, and also provided that no heavy trains are ever compelled to stop on that grade. Herein lies the danger and the possible misuse of this method.

A grade might be laid out substantially as shown in Fig. 157, with the intention of running all heavy trains up that grade without stopping. Later, another railroad might require and make a grade crossing at or near  $C$ , which would occasionally require that

trains shall stop at the crossing, and such loaded trains would be unable to start against such a grade, especially since the tractive resistance to starting is so much greater than the resistance at ordinary speeds. The chief value of such a method lies in the fact that it enables the engineer to determine the actual demand on the locomotive, as it is affected by the velocity of the train. The "undulatory" profile shown in Fig. 157 will probably be much cheaper to construct than the uniform grade  $A E$  which would involve a fill at  $B$  and a cut at  $D$ . The method of a virtual profile will show at once whether such a profile at that place will be a permissible way of economizing in spite of the fact that it introduces a 1-per-cent grade which is perhaps higher than the ruling grade. Many of the "improvements of old lines" depend on this process for their solution.

For example, a grade which always may have been harmless and unnoticed suddenly becomes important when it becomes desirable or necessary to require all heavy trains to stop at some point on it; such a case is sketched in Fig. 158. The above method indicates how such a problem may be investigated. The grade  $C D'$  of course becomes the critical grade, but under given conditions the virtual profile will show the demand on the locomotive. Examples of this will be given later. Undulatory grades have the advantage of decreasing the cost of construction and of being harmless under given conditions, but there are some dangers.

$C D E$  in Fig. 157 is called a "hump" in the grade. In the numerical case given it is only 4.8 feet and would be harmless under almost any conditions, but if it were considerably more, and if a train when passing  $C$  had a velocity much less than 20 miles per hour, it might become stalled before reaching the summit of the hump. Slippery rails or a strong head wind may so increase the resistances against which a train works that if the computed margin of velocity head at the top of a hump is made too small it may be entirely overcome and the train may be stalled before it is safely over the hump. A velocity of 5 miles per hour, which corresponds to a velocity head of only 0.88 feet is the least margin that should be safely allowed. This is also partly due to the fact that when the velocity becomes less than 5 miles per hour the resistances per ton increase, and as the velocity drops very low they increase



**RAILROAD BUILDING IN THE ANDES MOUNTAINS**

Remarkable bend in the Caeray-Oroya line, Peru

*Photo by American Stereoscopic Company*





very rapidly and the law on which the above calculations are based becomes inoperative.

Another danger is that a sag may be so deep that trains will acquire an excessive velocity when passing through it unless brakes are applied. This of course does not mean that the sag must not be used. It simply means that the sag will cause a waste of energy in brakes, a waste which must afterward be made up by increased work from the locomotive. This, consequently, is one of the cases which requires computation, by methods which follow, to determine whether or to what extent the sag is justifiable so that the two items of increased first cost and increased operating expenses shall be made a minimum. For example, a freight train may approach a sag with a velocity of 20 miles per hour. Its velocity head is therefore 14.05 feet. If the sag at its lowest point is 40 feet lower than the imaginary grade line on which the train could have run without changing its velocity (the grade  $A B'$  in Fig. 157), then the velocity head of the train at the bottom of the sag would be 54.05 feet, which corresponds to a speed of 39.2 miles per hour. Although this is a permissible speed with freight trains which are equipped with air brakes and automatic couplers, it is approaching the limit, and there might be some local conditions which would render even this speed through the sag inadvisable.

**182. Problems.** 1. If a train is running uniformly along a level grade at a speed of 35 miles per hour and reaches a 1.2-percent upgrade, how far up the grade could it run before its speed is reduced to 10 miles per hour?

Velocity head for 35 miles per hour = 43.01 feet

Velocity head for 10 miles per hour = 3.51 feet

Permissible increase in elevation = 39.50 feet

Distance from bottom of grade =  $39.50 \div .012 = 3292$  feet

2. At what speed may a train approach a sag 28 feet below the normal grade line so that its maximum speed at the bottom of the sag shall not exceed 36 miles per hour?

At 36 miles per hour the velocity head = 45.51 feet

Subtracting the depth of the sag = 28.00 feet

The permissible velocity is that due to 17.51 feet or 22.3 miles per hour.

## RESISTANCES

**183. Train Resistance.** The energy of the steam in the locomotive boiler is spent first in overcoming the various internal resistances between the boiler and the rims of the driving wheels. This engine resistance is computed later. Then the resistance due to the truck wheels of engine and tender and the atmospheric resistance together make up the difference (on a level track and at uniform velocity) between the adhesion at the drivers and the draw-bar pull. The draw-bar pull is spent, as discussed herewith, in overcoming the effect of (1) grade, (2) curvature, (3) the normal track resistance on a straight-level track at uniform velocity, (4) the force required to accelerate and (5) the starting resistance.

(1) *Grade Resistance.* Grade resistance is readily determinable with mathematical accuracy and equals 20 pounds per ton (of 2000 pounds) for each per cent of grade. For example, the grade resistance on a 1.2-per-cent grade is  $20 \times 1.2 = 24$  pounds per ton.

(2) *Curvature Resistance.* Curvature resistance is usually considered to be the equivalent of a .035-per-cent grade for each degree of curvature, although the resistance varies somewhat, depending on the velocity, and on the superelevation of the outer rail, the resistance being greater if the velocity is much less than that for which the superelevation was designed. This is the value usually taken in computing the compensation for curvatures (see article 176). Then the resistance in pounds per ton equals  $20 \times .035 = 0.7$  pound for each degree of curvature.

**Examples.** 1. What is the curvature resistance per ton on a 4-degree curve?

*Solution.*  $4 \times 0.7 = 2.8$  pounds per ton

2. What is the combined curvature and grade resistance on a 6-degree curve, located on a 2.2-per-cent grade?

*Solution.* The grade equivalent to the curve  $= 6 \times .035 = 0.21$ , which added to 2.2 = 2.41 per cent, the equivalent grade.  $20 \times 2.41 = 48.2$  pounds per ton, the resistance.

(3) *Normal Track Resistance.* Normal track resistance is a combination of several resistances which are variously affected by changes in conditions. The resistance to the rolling of wheels on the rails is a very small part of the total resistance. Accurate tests of journal friction show that the friction of axles in their bearings is actually less at higher velocities, probably because the resulting higher

temperature reduces the friction. The total varies with the number of cars in the train. The resistance per ton is much lower as the load per wheel increases. The atmospheric resistance of freight trains evidently depends on whether the train is made up of only one type of car (box, flat, or gondola), or of a combination of types, which would increase that resistance. Numerous experiments have been made, by placing a dynamometer between the locomotive and first car, to determine the amount of the tractive force and to discover its variation with velocity and its other laws. Of course it was necessary, when analyzing the results of these tests, to deduct first the effect of grade, curvature, and acceleration or retardation; but even then the results are so far from uniform that no set of numerical values can be uniformly applied to all grades of track. This variation is due to the very evident fact that the resistance would be less on a high-grade, well-kept track, with heavy rails than on a cheap, rough track, with light rails. But there is one very significant and surprising result which may be deduced from each series of tests, and that is, that a formula which makes the resistance equal a constant times the number of tons plus another constant times the number of cars, but with no variation depending on velocity, will satisfy the dynamometer results as closely as any other equally simple law. This statement applies to freight trains between the velocities of 5 miles and 35 miles per hour. When starting the resistance is greater. At higher velocities than 35 m.p.h. the resistance is also greater, but since the economies of reduced resistance apply chiefly to freight trains at usual working velocities, the simplicity of the above law is important. Each set of tests on any given piece of track will give a new pair of constants for the resistance formula. A compilation of the results of many tests gave the following, issued by the American Railway Engineers Association, as an average formula:

$$R = 2.2 T + 121.6 C \quad (105)$$

in which  $R$  is total resistance at uniform velocity on a level tangent;  $T$  is total weight of cars and contents, in tons; and  $C$  is number of freight cars in train.

It should be clearly understood that the formula does not necessarily give the actual resistance for any given case, since the

resistance will depend on the actual condition of the track, but the result will be a good average result and *for comparative purposes* the formula is useful.

The resistance of trains at higher velocities than 35 miles per hour must be considered as depending on velocity. The formula used by the Baldwin Locomotive Works is

$$R = 4.3 + 0.0017 V^2 \quad (106)$$

in which  $R$  is the resistance per ton, and  $V$  is the velocity in miles per hour. The formula is particularly applicable to passenger trains having cars weighing 45 tons and over. For lighter cars, the freight-train formula should be used. The formula should not be used for low velocities, especially those below 10 miles per hour, nor for light-weight cars.

**Example.** Assume that there are 33 freight cars weighing, with contents, 2200 tons. What is the total resistance behind the engine?  
Applying equation (105)

$$R = 2.2 \times 2200 + 121.6 \times 33 = 8853 \text{ pounds}$$

As an illustration of variations in results, depending on variations in track condition, some tests on the Baltimore & Ohio Railroad were reduced to a formula similar to equation (105) but with the constants, 2.78 and 113.9. Using these constants and applying the formula to the above numerical case, the computed value of  $R$  would be 9875, an increase of nearly 12 per cent. This variation shows the uselessness of attempting to apply any definite numerical values and to expect accuracy unless the resistance of the particular track in question has been determined by actual test.

(4) *Accelerative Force.* Accelerative force has been computed theoretically in article 179. The formula for acceleration may also be applied to determine how far the kinetic energy in a train will help to force it up a grade which is greater than that up which the locomotive could haul such a train indefinitely.

(5) *Starting Resistance.* As previously stated, the resistance per ton when starting a train is considerably in excess of the ordinary resistance. When cars have been left standing for several hours, or even days, especially in winter weather, it may take a force of 40 pounds per ton to produce motion. The bearings become "frozen". But such resistance is only momentary and may be

partly overcome by the impact of moving cars or engine striking against the stalled cars. When an engineer reverses his engine, backs it against the cars, and then immediately reverses again so as to go forward, he accomplishes three things: (1) the journals become loosened from the comparatively rigid condition they will assume even during a short stop; (2) the springs of the couplers will become compressed during the small backward motion and their expansion during forward motion will materially assist the forward motion; (3) if the train is very long, the total slack in the couplers is very considerable and the locomotive will have moved several feet before the last car begins to move and the cars are started one by one. Such devices in operation reduce to a variable extent the resistance which would be encountered if all cars were started at the same instant. A series of tests on the Rock Island system gave results with an ordinary range from 10 to 18 pounds per ton and averaging 14.1 pounds. An extreme value of 30 pounds was noted for "frozen bearings" and a low extreme of only 6 pounds extra when the stop was only momentary. Since a juggling of the train can produce virtually the same result as a mere momentary stop, the necessary extra starting resistance for a limiting case will be considered as only 6 pounds per ton in solving some numerical problems in a later article.

**Example.** How much draw-bar pull will be required to haul a freight train of 10 cars, each weighing 70 tons, and a caboose weighing 15 tons, at a uniform velocity of 15 miles per hour up a 0.9-per-cent grade?

*Solution.* The only significance of the 15 m.p.h. in the solution is the fact that it is between 5 and 35 and that equation (105) is applicable. The grade resistance per ton is  $20 \times 0.9 = 18$  pounds, and for the 11 cars weighing 715 tons it is  $715 \times 18 = 12,870$  pounds. The tractive resistance, by equation (105), is

$$R = 2.2 \times 715 + 121.6 \times 11 = 2911 \text{ pounds}$$

Adding the grade resistance, the total resistance would be 15,781 pounds.

The above problem assumed gondola cars weighing 40,000 pounds and each carrying 100,000 pounds and a 15-ton caboose. Suppose that the train consisted of empties, say 35 empties at 20 tons each, or 700 tons, and the 15-ton caboose. The total weight being the same, the grade resistance is the same. But the number of cars being greater, the tractive resistance is greater and

$$R = 2.2 \times 715 + 121.6 \times 36 = 5951 \text{ pounds}$$

which is an increase of 3040 pounds, and the tractive resistance is more than doubled. It should be noted that if there were no grade, the tractive resistance would be only 2911 pounds for the loaded train and 5951 pounds (over twice as much) for the empty train of the same gross weight. On the other hand, on the 0.9-per-cent grade the resistance of the loaded train would be 15,781 pounds and that of the train of empties  $5951 + 12,870 = 18,821$  pounds, which is only 19 per cent greater. The average tractive resistance per ton of the loaded train is  $2911 \div 715 = 4.07$  pounds, while that of the empty train is  $5951 \div 715 = 8.32$  pounds. The grade resistance is constant in either case at 18 pounds per ton. The character of the train load, whether loaded or consisting of a long train of empties of the same gross weight, is thus a matter of great importance on a level or nearly level road and becomes of much less importance on a grade of even 0.9 per cent. On a 2-per-cent grade the tractive resistance is comparatively small and variation in the character of the loading is of still less importance.

**Example.** How much tractive force will be required, using the data of the previous example, to increase the velocity from 15 m.p.h. to 20 m.p.h. in a distance of 500 feet?

*Solution.* Applying equation (104) we have  $V_1 = 15$ ,  $V_2 = 20$ , and  $s = 500$ . Then

$$P = \frac{70}{500}(20^2 - 15^2) = 24.5 \text{ pounds per ton}$$

For the 715-ton train, this will require an extra pull of 17,518 pounds. This is the equivalent of a  $24.5 \div 20 = 1.225$ -per-cent grade. Whether the locomotive has sufficient tractive force to pull 15,781 pounds of tractive force and grade resistance and 17,518 pounds more for acceleration, or a total of 33,299 pounds, is a matter to be studied under "power of the locomotive", article 189. The further question would arise, could the locomotive make steam fast enough to produce this energy? This will be considered in article 189.

**Example.** What is the tractive resistance behind a passenger engine of a load of 4 cars, each weighing 52 tons and traveling at a velocity of 60 miles per hour?

*Solution.* Substituting in equation (106) the value of  $V = 60$ , we obtain  $R = 10.42$  pounds per ton, and for the 208 tons the draw-bar pull would be 2167 pounds.

Irrespective of the resistance of the locomotive itself, considered later, this pull of 2167 pounds at a velocity of 60 m. p. h., or 88 feet per second, is the equivalent of  $88 \times 2167 = 190,696$  foot-pounds per second, or, dividing by 550, equal to 346 horsepower.

#### PULLEY POWER OF LOCOMOTIVES

**184. Rating of Locomotives.** Since it is very important for the economical operation of roads that each locomotive should be loaded to the limit of what it can efficiently haul, and since, as shown in article 183, the hauling power of a locomotive, especially on a flat grade, depends on the number of cars as well as on their gross weight, it is important to determine for each locomotive a loading which will measure its power and which is independent of the number of cars or of the rate of grade. This loading is called its "rating" and by applying to the rating a proper correction, depending on the number of cars and grade, the hauling power or the proper loading of that locomotive for any grade may be readily determined.

Let  $P$  be pulling power of the locomotive, or the tractive power as measured at the rim of the drivers;  $E$  weight of engine and tender, in pounds;  $W$  weight of cars behind tender, in pounds;  $R$  rate of grade, or ratio of vertical to horizontal;  $K$  a constant which, as determined by tests, is the factor 2.2 pounds per ton, in equation (105);  $C$  a constant which, as determined by tests, is the factor 121.6 pounds per ton, in equation (105);  $N$  number of cars in the train; and  $A$  the desired rating. Then

$$P = (E + W)(R + K) + NC$$

transforming,

$$\frac{P}{R + K} - E = W + N \frac{C}{R + K}$$

The right-hand side of this equation is the weight of the train behind the tender plus the number of cars times a quantity made up of two constants and the rate of grade. This right-hand side of the equation is called the rating, or  $A$ . Values of the fraction  $C \div (R + K)$ , in tons per car, which are independent of engine or train characteristics, are tabulated for various rates of grade, as given in Table XVIII. In computing these values, since  $C$  and  $K$  are resistances per ton,  $R$  must be the resistance per ton for the rate of grade considered.



TABLE XVIII

Values of  $C \div (R+K)$  for Various Grades  
(In tons per car)

GRADE $R$ (per cent)	TONS PER CAR $C \div$ $(R+K)$	GRADE $R$ (per cent)	TONS PER CAR $C \div$ $(R+K)$	GRADE $R$ (per cent)	TONS PER CAR $C \div$ $(R+K)$	GRADE $R$ (per cent)	TONS PER CAR $C \div$ $(R+K)$	GRADE $R$ (per cent)	TONS PER CAR $C \div$ $(R+K)$
Level	55	0.5	10.0	1.0	5.5	1.5	3.8	2.0	2.88
0.1	29	0.6	8.5	1.1	5.0	1.6	3.6	2.1	2.75
0.2	20	0.7	7.5	1.2	4.6	1.7	3.4	2.2	2.63
0.3	14	0.8	6.7	1.3	4.3	1.8	3.2	2.3	2.52
0.4	12	0.9	6.0	1.4	4.0	1.9	3.0	2.4	2.42

**Examples.** 1. Assume that the pulling power  $P$  of a locomotive, or the power at the rim of the drivers, computed as in article 190, was estimated to be 33,742 pounds and that the weight  $E$  of the engine and tender was 315,000 pounds. On a 0.5-per-cent grade  $R = .005$  and  $K = 2.2$  pounds per ton or .0011 pound per pound.

*Solution.*

$$A = \frac{P}{R+K} - E = \frac{33,742}{.005 + .0011} - 315,000 = 5,216,000 \text{ pounds} = 2608 \text{ tons}$$

which is the rating for a 0.5-per-cent grade. Similar ratings for that locomotive may be easily computed for all rates of grade. Such a locomotive may haul on any grade a load  $W$  such that  $A = W + N C \div (R+K)$ . From Table XVIII we find that, for a 0.5-per-cent grade,  $C \div (R+K) = 10$ . If there are 40 cars in the train, then

$$\begin{aligned} 2608 &= W + (40 \times 10) \\ W &= 2608 - 400 = 2208 \text{ tons} \end{aligned}$$

which is an average of 55 tons per car. If the cars are of uniform weight (such as empties, weighing say 18 tons) then  $W = 18 N$ , and the equation becomes

$$2608 = 18 N + 10 N = 28 N$$

and

$$N = 93$$

which means that such an engine can haul a load of 93 empties, each averaging 18 tons, up a 0.5-per-cent grade at a uniform velocity. Note that this ignores curvature resistance, which if it exists is assumed to be provided by a compensation of the grade.

2. What would be the rating for the same locomotive on a long 1.6-per-cent grade?

*Solution.*

$$A = \frac{33,742}{.016 + .0011} - 315,000 = 1,658,000 \text{ pounds} = 829 \text{ tons}$$

By Table XVIII, the "adjustment" in tons per car is 3.6. Again considering empties weighing 18 tons, we would have

$$829 = 18 N + 3.6 N = 21.6 N$$

and

$$N = 38$$

If all cars were loaded and had an average weight of 56 tons, we would have

$$829 = 56 N + 3.6 N = 59.6 N$$

$N$  = nearly 14, or say 13 loaded cars and the caboose

In the above examples the pulling power  $P$  is determined on the basis of the locomotive working at the maximum velocity  $M$  at which it can maintain full stroke. See article 190. This represents practically the maximum power of the locomotive. The velocity  $M$  is usually from 4 to 7 miles per hour and is as low as should be allowed on maximum grades, since an attempt to utilize a slightly higher tractive force at a somewhat lower velocity would probably result in stalling the train if an unexpected resistance in the track slightly increased the normal resistance.

**185. Units of Operation.** A large part of the calculations in railroad economics consists of a valuation of changes in alinement or the financial value of a reduction of distance, curvature, rise and fall, and ruling grade. Formerly such calculations were made exclusively on the basis of the cost of an average *train-mile*, especially as this is shown to be surprisingly constant for roads of all characters, long and short, heavy traffic and light traffic. The general method was to take up each item in turn of the average cost of operating trains and to estimate the effect of a change in alinement on the normal average percentage of each item. Some of the items are affected very materially; others are affected very little or not at all. The normal average for each item was then multiplied by the percentage by which that item was estimated to be affected by that unit change in alinement conditions, and then the sum of these products would be the computed percentage by which that unit change of alinement would affect the average cost of a train-mile. Further study has shown that the cost of fuel, for example, for freight trains is disproportionately high. Therefore, when comparing the relative costs of operating freight locomotives on two different grades, it will not do to base the estimate of increased fuel demand on the average cost of fuel for locomotives of all kinds. But it has become increasingly apparent that the effect of grade, for example, on the cost of operating a train is largely dependent on the weight of the train, on the character of the locomotive and its rating. Therefore the effect of grade cannot be measured by any one factor times the number of train miles involved.

Some of the elements of variation of operating expenses are more accurately measured by the number of *ton-miles*. A study of the effect of rolling stock on track maintenance shows that it is largely dependent on train velocity and also on intensity of axle loading. Although exact ratios are not computable, it has been broadly estimated that passenger trains, having a much higher average velocity, are responsible for twice as much track damage as the same tonnage of freight trains; also that locomotives, having heavier axle loads and not being truly counterbalanced, are responsible for twice as much track damage as the cars of the same train, which would mean that the locomotive of a high-speed passenger train would do four times as much damage as the car axles of a slow freight.

The *passenger-mile*, although frequently used in statistics of service rendered by railroads, has little or no relation to the cost of service and therefore is not used in problems of changes in alinement and grade.

The *car-mile* is a useful unit for some special purposes. If a steel passenger car weighs 100,000 pounds and carries even its maximum load of 80 passengers with an average weight of 125 pounds, the total live load (10,000 pounds) is only 10 per cent of the dead load. And when, as is usual, the actual live load is only a part, and perhaps a small part, of the possible load, then it makes but little difference in the tractive force required for hauling, especially on low grades, whether the car is loaded or empty. Other items of expense vary almost directly as the number of car-miles.

The *engine-mile* is similarly a useful unit in estimates in which certain costs vary as the number of engine-miles and nearly or quite regardless of variations in other factors.

Another element of practical cost in the operation of trains over a division is the *total time* required for a run by the slow freight trains. The old methods would invariably indicate that the most economical grades, using locomotives of a certain power, were those which would permit the maximum train load, even at the slowest velocity. But it was later developed that it is actually more economical to run somewhat lighter trains at a higher velocity; and that there is a certain combination of train load and velocity beyond which, if the train load is increased and the time of run increased,

the extra fuel burned, the extra time of the train crews, and the extra blocking of the tracks (especially on a single-track road) more than offset the economy of increased tonnage in one train. A consideration of these various elements and units of operation shows the impracticability of adopting any uniform unit values for one foot (or mile) of distance saved, or of one degree of curvature saved, or for each  $\frac{1}{10}$  per cent of grade lowered, which would be sufficiently accurate for universal applicability, and that the only accurate method of studying the value of a proposed change of alinement for handling an assumed amount of business, with an assumed type of locomotive, is to estimate the power of that locomotive on each of the two grades (or other variations of alinement) and the relative number of trains, with their cost of operation, in order to handle that business. If the problem is a suggested change in an existing road, the investigator has the advantage of an opportunity to study what the locomotive in use can do on the existing alinement and grades, and he has only to compute the effect of the changes. If the problem is a suggested change in a proposed new line, the cost of operation under both conditions must be estimated.

**186. Types of Locomotives.** The variations in locomotive service have developed all conceivable types as to total weight, ratio of total weight to weight on drivers, types of running gear, relation of steaming capacity to tractive power, etc. The method of classification on the basis of the running gear is very simple. The number of wheels on both rails of the pilot truck, if any, is placed as the first of three numbers. If there is no pilot truck, the character 0 is used. This is followed by the number of drivers and then by the number of trailing wheels, if any. For example, a Pacific-type engine has four wheels on the pilot truck, six driving wheels, and two trailing wheels under the rear of the boiler. The wheel base is symbolized as 4-6-2. The most common types of locomotives, with their popular names and wheel-base symbols, are

American	4-4-0	Consolidation	2-8-0
Columbia	2-4-2	Mikado	2-8-2
Atlantic	4-4-2	Mastodon	4-8-0
Mogul	2-6-0	Santa Fe	2-10-2
Ten-wheel	4-6-0	Mallet	A-B-B-A
Pacific	4-6-2	A = truck wheels, usually 2 or 0	
Six-wheel switcher	0-6-0	B = drivers, varying from 4 to 10	

The Interstate Commerce Commission report for 1912 showed 534 locomotives of the "Mallet" type, out of a total of 62,262 in the U. S. This is less than 1 per cent but, considering that the growth in numbers of this type in one year was nearly 23 per cent while the increase in all classes was about  $1\frac{1}{2}$  per cent, or that more than 10 per cent of the net increase was of this type, it deserves special mention. Excluding freak variations, they are always "four-cylinder compounds", one pair of cylinders discharging into the other pair and then exhausting. They have from five to ten driving axles, and have a length of engine wheel-base up to nearly 60 feet. Sometimes the boiler is made "flexible" by a set of accordion-shaped steel rings forming a joint in the boiler shell. The boiler proper is on one side of the joint and the feed-water heater, the reheater, and perhaps the superheater are on the other side. Or, the boiler shell is made rigid, one end is rigidly attached to the frame carrying the high-pressure cylinders and the other end is supported on a bearing on the truck frame which carries the low-pressure cylinders and the drivers operated by them. The low-pressure truck frame swings around a pivot in the fixed frame and this so cuts down the length of rigid wheel-base that these engines are operated successfully on 20-degree curves, and are therefore practicable on any road having reasonable alinement. These locomotives are chiefly used by roads handling large quantities of heavy freight, such as coal, up long stretches of heavy grades, where the demand for tractive power is very great. The tractive power of some of these locomotives is over 110,000 pounds, which is nearly four times as great as that of the average locomotive in the United States.

**187. Oil-Burning Locomotives.** In 1912 over one-sixth of all the locomotives west of the Mississippi River used oil as fuel. Some of the advantages in using oil are as follows: (1) the British thermal units in one pound of oil vary from about 19,000 to 21,000; those in a pound of coal vary from perhaps 14,000 down to 5000 for the poorer grades of lignite found in the western part of the United States and this means a great reduction in the cost of carrying and storing fuel, measured in heat units; (2) the cost of handling fuel is reduced and that of disposing of ashes is eliminated; (3) engine repairs are reduced in many respects although it is said that the increased cost of fire-box repairs, due to the intense heat of the oil

flame, offsets any reduction in other items; (4) the fires can be more easily controlled and waste of heat reduced during stoppages or when drifting down grade; (5) wayside fires due to sparks are altogether eliminated; (6) there is a practical limitation (see article 189) to the amount of coal that one fireman can feed to a fire, but there is no such limitation when using oil; (7) there is an equality in cost of heat units when a 42-gallon barrel of oil, weighing 7.3 pounds per gallon, costs 60 cents and a ton (2000 pounds) of coal, having two-thirds as many heat units per pound, costs \$2.61, or 4.35 times as much. The other items of difference almost invariably favor the oil and might make it more desirable even when the ratio of cost seemed to favor the coal. Oil is used very extensively west of the Mississippi River, where in many places oil is plentiful and cheap and coal is poor in quality and high in price.

#### 188. Relation of Type to Service and to Track Conditions.

Economy in operating conditions requires a thorough co-ordination between the characteristics of the locomotive, the fuel it is to burn, the roadbed and track it is to run on, and the character of service it is to render. It may not even be the best economy to use the same type of locomotive, for a given kind of service, on consecutive divisions of the same road.

*Wheel-Load to Rail-Weight.* Since the support which the rail receives from the ties and ballast is uncertain and variable, any rule for the relation must be empirical and approximate. The rule adopted by the Baldwin Locomotive Works ("300 pounds of wheel per pound of rail per yard") may be used in making a diagram from which the relation between total weight on driving wheels, number of drivers, and weight of rail, may be readily observed, Fig. 159.

For example, if it is desired to use a type of locomotive with 170,000 pounds on the drivers and also 75-pound rails, four pairs of drivers will be needed. By using 95-pound rails the same weight on drivers could be placed on three axles. As another example, a Pacific-type locomotive, with 150,000 pounds on its six drivers, should have a rail with a minimum weight of 83 pounds, or say an 85-pound rail.

**189. Power of Locomotives.** The tractive power of a locomotive, or its "draw-bar pull" is limited by the adhesion of the drivers, and by the capacity of the boiler to make steam. The

adhesion of the drivers is a fairly definite ratio of the weight on the drivers. Under very favorable conditions, with a dry rail and using sand, a ratio of one-third and over can be obtained. As

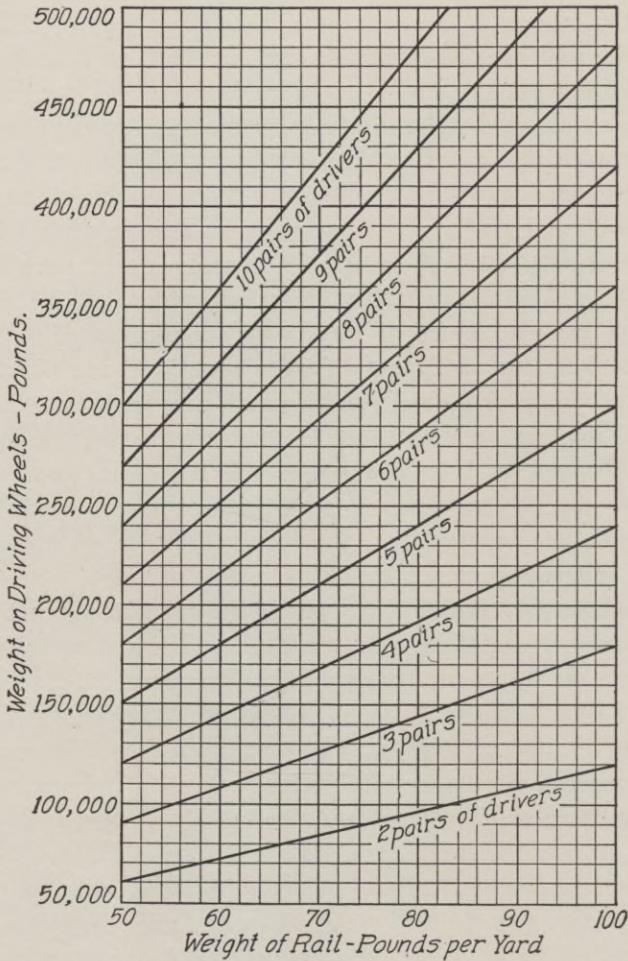

Fig. 159. Curves for Finding the Number of Drivers Needed for Given Weight on Driving Wheels and Weight of Rails

an ordinary value one-fourth ( $\frac{1}{4}$ ), or perhaps nine-fortieths is more usual. Under unfavorable conditions, the ratio reduces to one-fifth ( $\frac{1}{5}$ ), or less. The capacity of the boiler to make steam depends on the grate area, the heating surface, and (in the case of

modern heavy freight locomotives) the capacity of the fireman to shovel coal.

Experience shows that an average fireman, when he must maintain the full power of the locomotive for long periods of time, can handle about 4000 pounds of coal per hour, although individual performances, in special test cases and for short periods of time, have given much higher values. It may occasionally be admissible to estimate on extra work up to 5000 pounds per hour for a short period, provided it is preceded or followed by easier work. The use of automatic stokers can raise this hourly consumption very considerably (say up to 7000 pounds) or up to the capacity of the locomotive to burn coal properly, whatever it may be for the particular type. There is of course no such limitation in the use of oil-burning locomotives, which now include about 7 per cent of the total number in the United States. These are the exceptional cases.

The power developed by any given type of locomotive depends largely on the characteristics of the coal used. A British thermal unit (symbolized as B.t.u.) is the quantity of heat required to raise the temperature of 1 pound of pure water  $1^{\circ}$  Fahrenheit, when the water is at or near its maximum density at  $39.1^{\circ}$  Fahrenheit. When it is said that a certain grade of coal has 14,000 B.t.u. it means that the heat in 1 pound of that coal will raise the temperature of 14,000 pounds of water  $1^{\circ}$ , or, approximately, 100 pounds of water  $140^{\circ}$ . But although it only requires 180.9 heat units to heat water from  $32^{\circ}$  to  $212^{\circ}$ , it requires 965.7 more heat units to change it from water at  $212^{\circ}$  to steam at  $212^{\circ}$ . It requires only 53.6 more heat units to change it from steam at  $212^{\circ}$  to steam at  $387.6^{\circ}$  or with a pressure of 200 pounds per square inch.

A study of locomotive tests made at the St. Louis Exposition resulted in the compilation of Table XIX, which is copied from the Proceedings of the American Railway Engineering Association, and is now included as Table 1, in the Economics section of their Manual. It was found that the steam produced per square foot of heating surface is very nearly proportional to the coal burned per square foot of heating surface. The results are purposely made about 5 per cent below the results obtained in the St. Louis tests to allow for ordinary working conditions.



TABLE XIX

Average Evaporation in Locomotive Boilers Burning Bituminous and Similar Coals of Various Qualities, and for Various Quantities Consumed per Square Foot of Heating Surface per Hour

(Based on feed water at 60° Fahrenheit, and boiler pressure 200 pounds)

COAL PER SQUARE FOOT OF HEATING SURFACE PER HOUR (lb.)	STEAM PER POUND OF COAL OF GIVEN THERMAL VALUE (lb.)					
	15,000 B.t.u.	14,000 B.t.u.	13,000 B.t.u.	12,000 B.t.u.	11,000 B.t.u.	10,000 B.t.u.
0.8	7.86	7.34	6.81	6.29	5.76	5.24
0.9	7.58	7.07	6.57	6.06	5.56	5.05
1.0	7.31	6.82	6.34	5.85	5.36	4.87
1.1	7.06	6.59	6.12	5.65	5.18	4.71
1.2	6.82	6.37	5.91	5.46	5.00	4.55
1.3	6.59	6.15	5.71	5.27	4.83	4.39
1.4	6.37	5.95	5.52	5.10	4.67	4.25
1.5	6.17	5.76	5.35	4.94	4.52	4.11
1.6	5.97	5.57	5.18	4.78	4.38	3.98
1.7	5.79	5.40	5.02	4.63	4.25	3.86
1.8	5.61	5.24	4.86	4.49	4.12	3.74
1.9	5.44	5.08	4.71	4.35	3.99	3.63
2.0	5.27	4.92	4.57	4.22	3.86	3.51
2.1	5.12	4.78	4.44	4.10	3.75	3.41
2.2	4.97	4.64	4.31	3.98	3.64	3.31
2.3	4.83	4.51	4.19	3.86	3.54	3.22
2.4	4.69	4.38	4.07	3.75	3.44	3.13
2.5	4.56	4.26	3.95	3.65	3.34	3.04
2.6	4.44	4.14	3.84	3.55	3.25	2.96
2.7	4.32	4.03	3.74	3.46	3.17	2.88
2.8	4.21	3.93	3.64	3.37	3.09	2.80
2.9	4.10	3.83	3.55	3.28	3.01	2.73
3.0	3.99	3.73	3.46	3.19	2.93	2.66

The quantity of steam evaporated for intermediate quantities or qualities of coal can be found by interpolation.

On bad-water districts deduct the following from tabular quantities:

For each  $\frac{1}{8}$  inch of accumulated scale. . . . . 10 per cent

For each grain per U. S. gallon of foaming salts in the average feed water. . . . . 1 per cent

**190. Power Calculations. Illustrative Example.** Assume that a Mikado locomotive, having a total heating surface of 2565 square feet is fired with coal whose samples test 13,000 B.t.u. On the basis that a fireman can handle 4000 pounds of coal per hour and maintain such work throughout his run, the coal may be fed at the rate



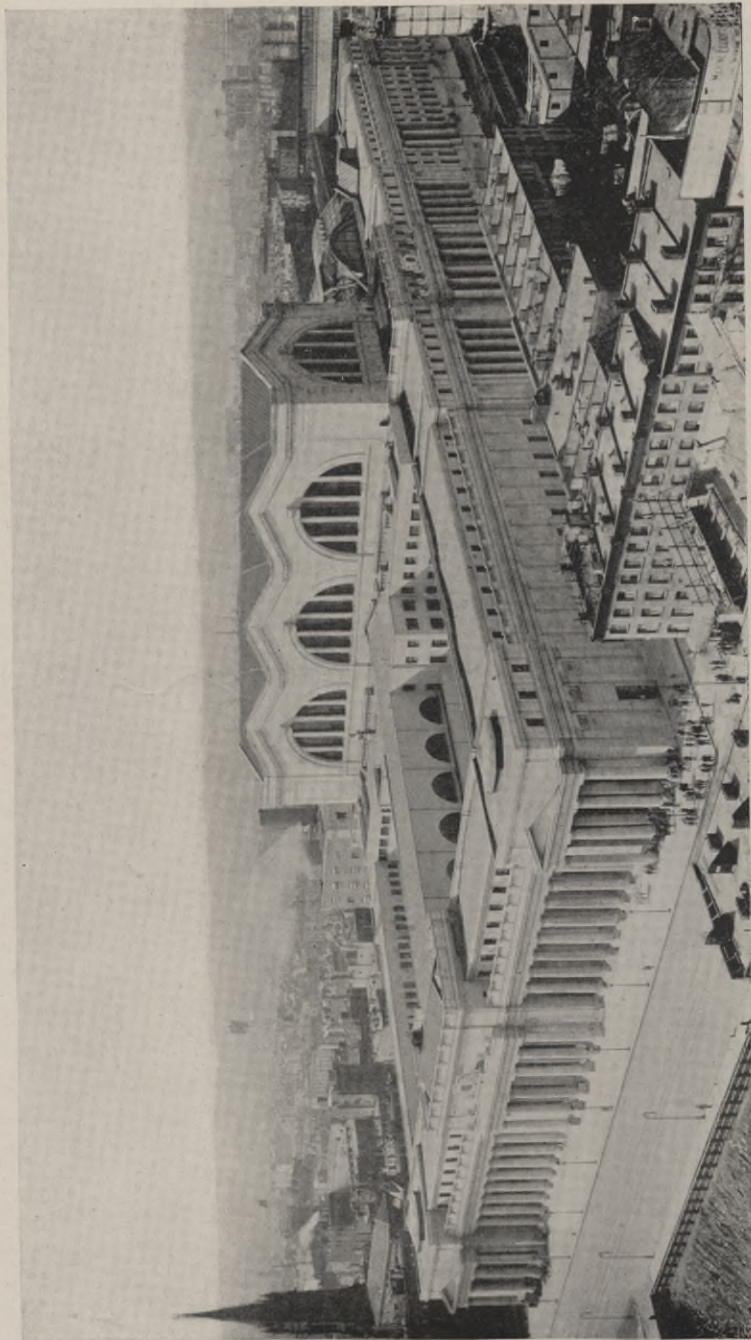

**BIRDSEYE VIEW OF THE WONDERFUL PENNSYLVANIA RAILROAD STATION, NEW YORK CITY**

*Photo by Boston Photo News Company, Boston, Massachusetts*

of  $\frac{4000}{2565} = 1.56$  pounds per hour per square foot of heating surface.

If the air-dried mine samples of the coal tested 13,000 B.t.u., the average run-of-car coal would have about 90 per cent of this, or 11,700 B.t.u. Interpolating in Table XIX for 1.56 and 11,700 we find that the pounds of steam per pound of coal would be 4.72. But since the locomotive is designed for use at 175 pounds gage pressure, instead of 200, as in Table XIX, the amount of steam produced will be about 0.3 per cent more, or say 4.73. The uncertainties of firing are so great that such small corrections may be ignored. But considering that a superheater is used in this locomotive, and that, with the usual superheater proportions and efficiency, 0.85 pound of superheated steam may be considered as having the same volume and pressure as 1 pound of saturated steam, the amount of steam developed by 1 pound of coal is equivalent to  $4.73 \div 0.85 = 5.56$  pounds. Then the equivalent amount of steam developed per hour equals  $5.56 \times 4000 = 22,240$  pounds.

The weight of steam used per stroke may be computed most easily by utilizing Table XX, which is also taken (but somewhat amplified) from the Proceedings of the American Railway Engineering Association, and now included as Table 2 in the Economics section of their Manual. The weight of steam per foot of stroke for 22 inches diameter and 175 pounds gage pressure is 1.106 pounds and for a stroke of 28 inches ( $2\frac{1}{3}$  feet) it is 2.581 pounds. For a complete revolution of the drivers it is  $4 \times 2.581 = 10.324$  pounds. Since the engine can develop the equivalent of 22,240 pounds of steam per hour and will use 10.324 pounds at one revolution, it can run at a speed of  $22,240 \div 10.324 = 2154$  revolutions per hour, or 35.9 revolutions per minute, at full stroke and maintain full boiler pressure. The drivers are 57 inches in diameter and therefore have a circumference of  $(57 \div 12) \times 3.1416 = 14.923$  feet. The maximum engine speed for full stroke is  $35.9 \times 14.923 = 535.7$  feet per minute. Multiplying by 60 and dividing by 5280, or dividing by 88, we have 6.087 miles per hour as the maximum speed at which full stroke can be maintained.

In Table XXI, also taken from the proceedings of the American Railway Engineering Association and now included as Table 4 in the Economics section of the Manual, are given the pounds of steam

TABLE XX

**Weight of Steam Used in One Foot of Stroke in Locomotive  
Cylinders**

(Cylinder diameter is for high-pressure cylinders in compound locomotives)

DIAMETER OF CYLINDER (inches)	WEIGHT OF STEAM PER FOOT OF STROKE FOR VARIOUS GAGE PRESSURES						
	220 Pounds per Square Inch (lb.)	210 Pounds per Square Inch (lb.)	200 Pounds per Square Inch (lb.)	190 Pounds per Square Inch (lb.)	180 Pounds per Square Inch (lb.)	170 Pounds per Square Inch (lb.)	160 Pounds per Square Inch (lb.)
12	0.405	0.389	0.370	0.354	0.337	0.321	0.304
13	0.475	0.456	0.435	0.415	0.396	0.376	0.357
14	0.551	0.529	0.504	0.482	0.459	0.436	0.414
15	0.633	0.607	0.579	0.553	0.527	0.501	0.476
15½	0.675	0.649	0.618	0.590	0.562	0.535	0.508
16	0.720	0.691	0.658	0.629	0.599	0.570	0.541
17	0.812	0.780	0.744	0.710	0.676	0.643	0.611
18	0.911	0.875	0.834	0.796	0.759	0.722	0.685
18½	0.962	0.924	0.881	0.841	0.801	0.762	0.724
19	1.015	0.975	0.928	0.887	0.845	0.804	0.763
19½	1.069	1.027	0.978	0.934	0.890	0.847	0.804
20	1.125	1.080	1.029	0.983	0.936	0.891	0.846
20½	1.181	1.134	1.081	1.032	0.984	0.936	0.888
21	1.240	1.191	1.134	1.083	1.032	0.982	0.932
22	1.361	1.307	1.245	1.189	1.133	1.078	1.023
23	1.487	1.428	1.361	1.300	1.238	1.178	1.118
24	1.620	1.555	1.482	1.416	1.348	1.283	1.218
25	1.758	1.688	1.608	1.536	1.462	1.392	1.322
26	1.901	1.825	1.739	1.661	1.582	1.506	1.430
27	2.050	1.968	1.875	1.792	1.706	1.624	1.542
28	2.204	2.117	2.017	1.926	1.835	1.745	1.657

For weight of steam used per revolution of drivers at full cut-off:

Multiply the tabular quantity by four times the length of stroke in feet for simple and four-cylinder compounds. For two-cylinder compounds multiply by two times the length of stroke.

per indicated-horsepower hour for simple and for compound locomotives for various velocities, which are multiples of  $M$ , the maximum velocity at which the boiler can maintain steam at full pressure. The table is computed on the basis of 200 pounds gage pressure, but factors are given for other pressures. For example, continuing the above numerical problem, the pounds of steam per i.h.p.-hour, for a simple locomotive, at  $M$  velocity, and at 200 pounds pressure, taken from Table XXI, is 38.30; for 175 pounds pressure we must multiply by the factor 101.7, which makes

TABLE XXI

Maximum Cut-Off and Pounds of Steam per I.H.P.-Hour for  
Various Multiples of *M*

(*M* is maximum velocity in miles per hour at full cut-off, with boiler pressure at 200 pounds per square inch)

VELOCITY	CUT-OFF (per cent)	POUNDS STEAM PER I.H.P.-Hour		VELOCITY	CUT-OFF (per cent)	POUNDS STEAM PER I.H.P.-Hour	
		Simple	Compound			Simple	Compound
1.0 <i>M</i>	Full	38.30	25.80	2.9 <i>M</i>	38.5	24.37	21.04
1.1 "	94.4	36.46	24.36	3.0 "	37.0	24.22	21.21
1.2 "	89.1	34.89	23.24	3.2 "	34.2	24.00	21.57
1.3 "	84.3	33.56	22.35	3.4 "	31.8	23.85	21.93
1.4 "	79.7	32.41	21.65	3.6 "	29.8	23.8	22.27
1.5 "	75.4	31.40	21.14	3.8 "	28.0	23.8	22.57
1.6 "	71.4	30.49	20.77	4.0 "	26.4	23.87	22.85
1.7 "	67.7	29.67	20.52	4.25 "	24.7	24.05	23.22
1.8 "	64.3	28.93	20.40	4.50 "	23.3	24.24	23.56
1.9 "	61.0	28.25	20.40	4.75 "	22.1	24.44	23.85
2.0 "	58.0	27.62	20.40	5.00 "	21.1	24.64	24.15
2.1 "	55.2	27.05	20.40	5.5 "	19.5	24.98	24.70
2.2 "	52.6	26.52	20.40	6.0 "	18.4	25.20	
2.3 "	50.1	26.06	20.40	6.5 "	17.6	25.45	
2.4 "	47.8	25.67	20.40	7.0 "	17.1	25.60	
2.5 "	45.7	25.32	20.47	7.5 "	16.7	25.70	
2.6 "	43.7	25.02	20.60	8.0 "	16.4	25.80	
2.7 "	41.8	24.76	20.73	9.0 "	16.1	25.90	
2.8 "	40.1	24.54	20.88				

For steam per i.h.p.-hour for other boiler pressures take the following percentages of values given in table:

160 lb., 103 per cent	180 lb., 101.3 per cent	210 lb., 99.5 per cent
170 lb., 102.1 per cent	190 lb., 100.6 per cent	200 lb., 99.2 per cent

the quantity 38.95. Dividing this into 22,240, the steam produced per hour, we have 571.0, the i.h.p. at *M* velocity. Multiplying this by 33,000, the foot-pounds per minute in one horsepower, and dividing by 535.7 the velocity in feet per minute, we have 35,174, the cylinder tractive power in pounds, when burning 4000 pounds of coal per hour and running at 6.087 m.p.h.

To obtain the draw-bar pull, we must deduct the engine resistances which may be computed as given in Table XXII, also taken from the Proceedings of the American Railway Engineering Association and now included as Table 7 in the Economics section of the Manual.

TABLE XXII  
Locomotive Resistances

Total Locomotive Resistance is  $A+B+C$ , in which  
 $A$  = resistance between cylinders and rims of drivers, and in pounds  
 $= 18.7 T + 80 N$  in which  $T$  = tons weight on drivers and  
 $N$  = number of driving axles.  
 $B$  = resistance of engine and tender trucks, and in pounds  
 $= 2.6 T + 20 N$  in which  $T$  = tons weight on engine and tender trucks  
and  $N$  = number of truck axles.  
 $C$  = head-end or "air" resistance, and in pounds  
 $= .002 V^2 A$  in which  $V$  = velocity in miles per hour, and  
 $A$  = end area of locomotive.

On the basis that the end area averages 125 square feet, the last formula becomes  $C = 0.25 V^2$ . The number of pounds air resistance for various velocities is as given below.

VE- LOC- ITY V	RESIST- ANCE C	VELOC- ITY V	RESIST- ANCE C	VELOC- ITY V	RESIST- ANCE C	VELOC- ITY V	RESIST- ANCE C	VELOC- ITY V	RESIST- ANCE C	VELOC- ITY V	RESIST- ANCE C
1	0.25	8	16.00	15	56	22	121	29	210	36	324
2	1.00	9	20.25	16	64	23	132	30	225	37	342
3	2.25	10	25.00	17	72	24	144	31	240	38	361
4	4.00	11	30	18	81	25	156	32	256	39	380
5	6.25	12	36	19	90	26	169	33	272	40	400
6	9.00	13	42	20	100	27	182	34	289	50	625
7	12.25	14	49	21	110	28	196	35	306	60	900

Draw-bar pull on level tangent equals the cylinder tractive power less the sum of the engine resistances.

At low speeds, the adhesion of the drivers should be considered and available draw-bar pull should never be estimated greater than 30 per cent of weight on drivers at starting with use of sand, or 25 per cent of weight on drivers at running speeds.

Applying Table XXII to the numerical problem, item  $A = (18.7 \times 76.6) + (80 \times 4) = 1432$  lb. The total weight of engine and tender is 315,000 pounds; subtracting 153,200, the weight on the drivers, we have 161,800, or 80.9 tons, the weight carried by the engine and tender trucks. Item  $B = (2.6 \times 80.9) + (20 \times 6) = 330$ . Item  $C$  for velocity  $M$  is almost insignificant, say 9 pounds. The sum of  $A$ ,  $B$ , and  $C$  is 1771 pounds; subtracting this from 35,174 we have 33,403 pounds, the estimated draw-bar pull for that speed and coal consumption.

To note the effect of increasing the rate of coal consumption, the problem may be again worked through on the basis that the rate of coal consumption is increased, even temporarily, from 4000

pounds to 5000 pounds per hour. The steam developed per pound of coal is reduced from 5.56 to 4.93, but the total steam produced per hour is increased from 22,240 to 24,650. The increased capacity comes through a loss in efficiency. The increased steam production raises the velocity at which full stroke may be maintained from 6.087 m.p.h. to 6.746 m.p.h. and the i.h.p. from 571.0 to 632.8. But the computed cylinder tractive power is practically identical, the numerical computation of 35,174 being only changed to 35,175. But these cylinder tractive powers are each computed for the "M" velocities, the maximum velocities at which full stroke can be maintained, and *M* is higher with increased coal consumption. For a real comparison, the figures must be reduced to the same velocity, e.g., the working velocity of 10 m.p.h.  $10 \div 6.087 = 1.643$ , the multiple for the original problem. For 5000 pounds of coal per hour, *M* velocity is 6.746 m.p.h., and the multiple is 1.482. From Table XXIII we find that the percentages of cylinder tractive power for simple engines for these two multiples of *M* are 77.44 and 81.93, respectively. The higher value is 105.7 per cent of the lower, which shows that, in this case, adding 25 per cent to the rate of coal consumption adds only 5.7 per cent to the cylinder tractive power at 10 m.p.h.

As another instructive variation of the same problem, assume that the coal has effective B.t.u. of 13,000, instead of only 11,700. It will be found that steam will be produced more rapidly, the *M* velocity is 6.777 m.p.h. and the horsepower at that velocity is 635.7, but the cylinder power is computed to be 35,177 pounds, which is again almost identical with the previous values although the *M* velocity is still higher. The multiple for 10 m.p.h. is 1.476 and by Table XXIII the per cent of cylinder tractive power is 82.11, which is an increase of 6 per cent over 74.44 per cent, showing that the increase in effective B.t.u. from 11,700 to 13,000 adds 6 per cent to the cylinder tractive power at 10 m.p.h.

These values for cylinder power may again be checked by the simple rule that

$$\text{Tractive force} = \frac{(\text{piston diameter})^2 \times \text{effective steam pressure} \times \text{stroke}}{\text{diameter of driver}}$$

The "effective steam pressure" is generally considered as 85 per cent of the gage pressure, and for the above case would be



TABLE XXIII\*

Per Cent Cylinder Tractive Power for Various Multiples of  $M$ 

( $M$  is maximum velocity in miles per hour at which boiler pressure can be maintained with full cut-off)

VELOCITY	PER CENT (Compound)	PER CENT (Simple)	VELOCITY	PER CENT (Compound)	PER CENT (Simple)	VELOCITY	PER CENT (Compound)	PER CENT (Simple)
Start	135.00	106.00	3.6 $M$	32.40	44.75	6.4 $M$		23.59
0.5 $M$	103.00	103.00	3.7 "	31.25	43.56	6.5 "		23.18
1.0 "	100.00	100.00	3.8 "	30.10	42.39	6.6 "		22.79
1.1 "	96.28	95.57	3.9 "	29.14	41.24	6.7 "		22.42
1.2 "	92.55	91.53	4.0 "	28.24	40.10	6.8 "		22.06
1.3 "	88.83	87.83	4.1 "	27.38	39.00	6.9 "		21.71
1.4 "	85.12	84.46	4.2 "	26.56	37.96	7.0 "		21.38
1.5 "	81.40	81.37	4.3 "	25.77	36.97	7.1 "		21.06
1.6 "	77.68	78.55	4.4 "	25.03	36.03	7.2 "		20.75
1.7 "	73.96	75.97	4.5 "	24.34	35.13	7.3 "		20.45
1.8 "	70.25	73.60	4.6 "	23.69	34.26	7.4 "		20.16
1.9 "	66.54	71.41	4.7 "	23.07	33.41	7.5 "		19.88
2.0 "	63.21	69.37	4.8 "	22.48	32.59	7.6 "		19.61
2.1 "	60.20	67.47	4.9 "	21.92	31.82	7.7 "		19.34
2.2 "	57.48	65.67	5.0 "	21.38	31.11	7.8 "		19.08
2.3 "	54.97	63.94	5.1 "	20.87	30.42	7.9 "		18.82
2.4 "	52.68	62.22	5.2 "	20.37	29.75	8.0 "		18.57
2.5 "	50.42	60.55	5.3 "	19.89	29.10	8.1 "		18.33
2.6 "	48.16	58.92	5.4 "	19.43	28.48	8.2 "		18.09
2.7 "	46.08	57.33	5.5 "	18.99	27.87	8.3 "		17.86
2.8 "	44.10	55.78	5.6 "		27.33	8.4 "		17.64
2.9 "	42.29	54.26	5.7 "		26.81	8.5 "		17.43
3.0 "	40.57	52.78	5.8 "		26.30	8.6 "		17.22
3.1 "	38.95	51.33	5.9 "		25.81	8.7 "		17.01
3.2 "	37.42	49.91	6.0 "		25.34	8.8 "		16.82
3.3 "	35.98	48.55	6.1 "		24.88	8.9 "		16.63
3.4 "	34.66	47.24	6.2 "		24.44	9.0 "		16.45
3.5 "	33.53	45.97	6.3 "		24.01			

\*Table 5 in Economics Section of Manual of American Railway Engineering Association.

.85×175=149 pounds; diameter piston=22 inches; stroke=28 inches; diameter of driver=57 inches. Then the tractive force =35,425 pounds, which is less than 1 per cent in excess of the other values. This rule is more simple as a method of obtaining merely the maximum tractive power at slow velocities, but the previous method, although longer, is preferable, since it computes the critical velocity  $M$ , and also the tractive force at higher velocities.

191. **Tractive Force at Higher Velocities.** At higher velocities than  $M$ , the cylinder power falls off quite rapidly, since the steam

is cut off at part stroke and is used expansively. The proper per cent of cut-off and the number of pounds of steam per i.h.p. are shown in Table XXI. In Table XXI is given the per cent of cylinder tractive power for multiples of  $M$ . The table shows, for example, that, for simple engines, the cylinder tractive power is 69.37 per cent of its value for full stroke when the velocity is  $2M$  and that when the velocity is increased to  $5M$  the tractive power is reduced to 31.11 per cent. Applying this to the above numerical problem, when  $M = 6.087$  m.p.h., the cylinder tractive power is reduced to 31.11 per cent of 35,174, or 10,943 pounds, but, since the velocity is five times as great, the horsepower developed is 31.11 per cent  $\times 5 = 1.55$  times as great. It should be noted that Table XXIII shows a slight excess of tractive power (6 per cent when starting) for the simple engine. This is due to the fact that with very low velocities the cylinder pressure more nearly equals the full boiler pressure and there is not the usual reduction of about 15 per cent. Also, compound locomotives are operated with all the cylinders using full-pressure steam, which increases their effectiveness at starting about 35 per cent, although at some loss in economy of steam due to compounding. But since the starting resistances are so much greater than the resistances above 5 miles per hour, the extra assistance is very timely.

**192. Further Power Calculations. Illustrative Example.** Continuing the investigation of the Mikado locomotive (see article 190), draw a curve representing its cylinder tractive power for all

VELOCITY		CYLINDER TRACTIVE POWER		LOCOMOTIVE RESISTANCE (pounds)	DRAW-BAR PULL (pounds)
(multiples of $M$ )	(miles per hour)	(per cent)	(pounds)		
0.0	0.000	106.00	37,284	1762	35,322
1.0	6.087	100.00	32,174	1771	33,403
1.2	7.304	91.53	32,195	1775	30,420
1.5	9.131	81.37	28,621	1783	26,838
2.0	12.174	69.37	24,400	1799	22,601
3.0	19.261	52.78	18,565	1854	16,711
4.0	24.348	40.10	14,105	1910	12,195
5.0	30.435	31.11	10,943	1993	8,950
6.0	36.522	25.34	8,913	2095	6,828

velocities from 0 to 35 miles per hour. From the numerical example worked out in article 190, we found that the cylinder tractive power for  $M$  velocity (6.087 m.p.h.) was 35,174 pounds. From Table XXIII,

the power at starting is 106 per cent of this, or 37,284 pounds, and the change in power is assumed to vary uniformly in that range. By multiplying 35,174 by the various percentages for the various multiples of  $M$ , we have the tractive power at the several velocities. These values are plotted in Fig. 160. From Table XXII we find that the locomotive resistance is 1762 pounds for the  $A$  and  $B$  resistance at all velocities and that the  $C$  resistance varies from about 9 pounds at  $M$  velocity (6.087 m.p.h.) to about 333 pounds at  $6M$  velocity. Subtracting these resistances from the computed values of cylinder tractive power, we have the "draw-bar pull" for the various velocities, all as shown in the tabular form. These several values for cylinder power and of draw-bar pull are plotted for the correspond-

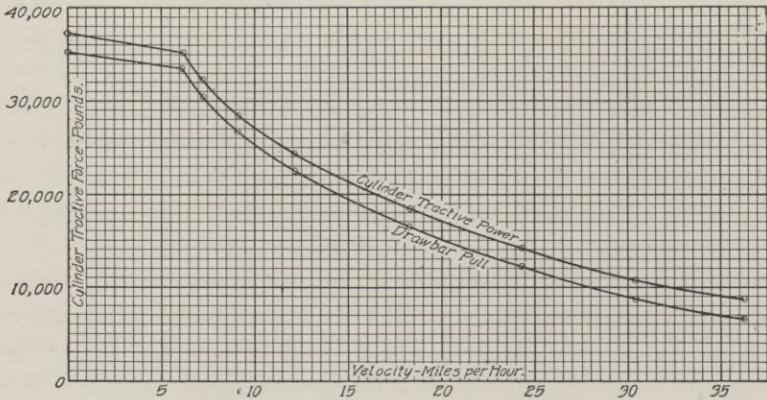

Fig. 160. Tractive Power of Mikado Locomotive at Varying Velocities

ing velocities in Fig. 160, giving the two curves as shown. The rapid decrease in possible draw-bar pull for increase in velocity is well shown. But the student should carefully note that this curve represents the *limitation* of draw-bar pull and not the *actual*, which may be considerably less and which is measured by the resistance.

**193. Relation of Boiler Power to Tractive Power.** The power at high velocities depends on the rapid production of steam, as has been shown, and this depends on the area of the fire box. All of the older styles of locomotives have fire boxes limited to the width which can be properly placed between the drivers. The Wootten fire box was placed over the drivers, which made it incon-

	MOGUL	PRAIRIE
Cylinders, diam. $\times$ stroke	20 in. $\times$ 26 in.	20 in. $\times$ 24 in.
Boiler pressure	200 pounds	200 pounds
Fire box, length $\times$ width	108 in. $\times$ 33 in.	74 in. $\times$ 66 in.
Grate area, square feet	24.70	34.000
Heating surface, sq. ft., fire box and tubes	1952.00	2135.000
Driving wheels, diameter, inches	51.00	51.000
Weight on driving wheels, pounds	137,300.00	122,100.000
Weight of engine alone, pounds	154,000.00	153,300.000
Weight of engine and tender, pounds	254,000.00	253,000.000
Assumed B.t.u. in coal used, 4000 lb. per hr.	12,000.00	12,000.000
Coal per sq. ft. of heating surface per hour	2.05	1.873
Pounds steam per pound coal (Table XIX)	4.16	4.390
Pounds steam per hour (multiply by 4000)	16,640.00	17,560.000
Pounds steam per stroke (Table XX)	2.230	2.058
Pounds steam per revolution (multiply by 4)	8.920	8.232
Revolutions per hour, at $M$ velocity	1865.50	2133.500
Revolutions per minute, at $M$ velocity	31.09	35.560
Circumference of drivers, linear feet	13.35	13.350
Velocity ( $v$ ), feet per minute, $M$ velocity	415.05	474.730
Velocity ( $V$ ), miles per hour, $M$ velocity	4.716	5.394
Horsepower at $M$ velocity (Table XXI)	434.40	458.400
Cylinder tractive power, pounds, at $M$ velocity	31,400.00	31,865.000

veniently high, unless the drivers were objectionably small. Then the plan was devised of placing the fire box over a low pair of trailing wheels and behind the rear pair of drivers. This plan made it possible to double the net width of the fire box. In order to get essential fire-box area in the older styles of locomotives, it is necessary to lengthen the fire box until it is difficult for the fireman to reach and properly clean and tend the fire at the forward end. But by doubling the width, the fire box may be made as large as desired and even shorter than some of the older designs. The

MULTIPLES OF $M$	MOGUL LOCOMOTIVE		PRAIRIE LOCOMOTIVE	
	Velocity (m.p.h.)	Cylinder Tractive Power	Velocity (m.p.h.)	Cylinder Tractive Power
0.0	0.000	33,284	0.000	33,778
1.0	4.716	31,400	5.394	31,865
1.2	5.659	28,740	6.473	29,166
1.5	7.074	25,550	8.091	25,929
2.0	9.432	21,782	10.788	22,105
3.0	14.148	16,573	16.182	16,818
4.0	18.864	12,591	21.576	12,778
5.0	23.580	9,769	26.970	9,913
6.0	28.296	7,957	32.364	8,075
7.0	33.012	6,713		

increased fire-box area justifies a greater heating surface and results in a greater production of steam per pound of coal and a more rapid production of steam, and hence greater power. The value of this change is best shown by a comparison of two locomotives which are very similar in many respects except those due to the difference in fire boxes, etc. The two locomotives are a "Mogul" (2-6-0) and a "Prairie" (2-6-2). The several characteristics, some of which are computed as in article 192, are best shown by tabulating them. (See top of p. 263.)

Knowing the cylinder tractive power at  $M$  velocity ( $M$  being somewhat different for the two locomotives), we can determine the

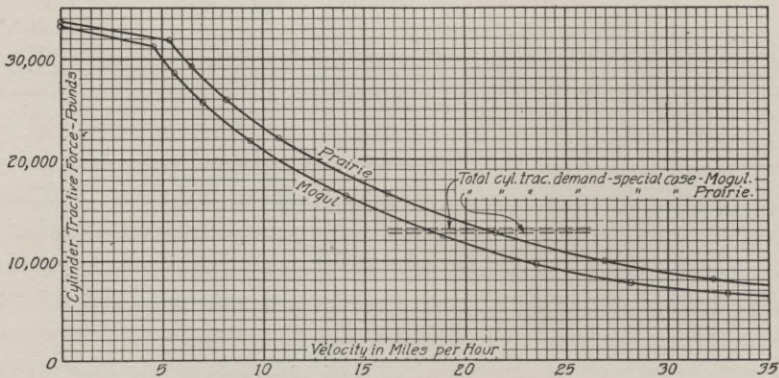

Fig. 161. Comparative Cylinder Tractive Power of Prairie and Mogul Types of Locomotive

cylinder tractive power for various multiples of  $M$ , by means of Table XXIII, by the method already given in detail. The results are tabulated at bottom of p. 263 and are plotted in Fig. 161.

The student should note that the two locomotives are of almost the same weight, have the same driving-wheel diameter, same cylinder diameter, same boiler pressure, and are compared on the basis of using the same quality of coal. The Mogul has 15,200 pounds extra on the drivers, which should apparently give it advantage, but Fig. 161 shows that, even at the start, the Mogul has slightly less tractive power. But the Prairie fire box is wider, although shorter, and has 38 per cent more area. This permits more rapid production of steam. By scaling the *vertical* intervals between the two curves at all points, it is found that for any veloc-

ities between 5.5 and 25 miles per hour the Prairie has about 2000 pounds more cylinder tractive power. Of course, the comparison should be made on the basis of their relative draw-bar pulls, which would be obtained by subtracting the engine resistances, as given in Table XXII. But this shows that the engine resistance of the Mogul is greater than that of the Prairie, which leaves an even greater difference in favor of the Prairie.

The trailing wheels under the fire box also serve the purpose of guiding the driving wheels around curves when the locomotive is running backward and in this respect accomplish what the pilot truck does for forward running.

The comparative power of these two locomotives may be shown by a numerical example. Assume that a train of 16 coal cars, each weighing when fully loaded 70 tons, and a caboose weighing 15 tons, is being hauled up a 0.3-per-cent grade at a uniform velocity of about 20 miles per hour. The resistance, by equation (105), is

$$R = 2.2 \times (16 \times 70 + 15) + 121.6 \times 17 = 4565 \text{ lb.}$$

The grade resistance of the cars is  $20 \times 0.3 \times 1135 = 6810$  pounds. It is assumed that all curve resistance is eliminated by a sufficient reduction of grade where it occurs so that it may be included with the grade resistance. The velocity being assumed uniform, there is no requirement for energy for acceleration. The total car resistance is therefore 11,375 pounds. The engine resistance is a function of the velocity, but considering that the element depending on velocity is relatively small, we will consider it at its average value for 20 miles per hour. The resistances may be computed as 1876 and 1532 for the Mogul and Prairie engines, respectively, which gives 13,251 and 12,907 pounds, respectively, for the total demands on cylinder tractive power. These resistances, being practically independent of velocity, are horizontal lines and are drawn as shown in Fig. 161. This indicates that the limit of velocity of the Mogul locomotive with that train on a 0.3-per-cent grade is less than 18 miles per hour, while the Prairie engine could haul the train at over 21 miles per hour. This gain of 3 miles per hour would have considerable value in the economy of train operation. Or, it may be shown that the Prairie engine could haul 19 loaded cars (an increase of over 18 per cent in revenue load) and a caboose, and

could haul them on the 0.3-per-cent grade at a velocity of 18 miles per hour, the limiting velocity for the Mogul.

The student should remember that, as before intimated, there are several elements of uncertainty (such as the strength and ability of the fireman, and the condition of the track) which might modify the above figures and make them unreliable as a precise measure of the real power of either locomotive, but, on the basis of average conditions, the figures are a measure of the *comparative* value of the two locomotives.

**194. Effect of Grade on Tractive Power.** The effect of grade on tractive power is best shown by some numerical computations whose results are plotted in Fig. 162. The cylinder tractive power was computed for three engines of greatly different total weight and power, but which had driving-axle loads nearly identical (about 50,750 pounds) and therefore, by the rule given in article 188, could all be operated on the same kind of track. Using the Baldwin Locomotive Works rule, as given in article 188,  $\frac{1}{2} \times 50,750 \div 300 = 84.5$ , which means that the rails should weigh at least 85 pounds per yard. Making computations for these locomotives, using 12,000 B.t.u. coal, similar to those already detailed in articles 190 to 193, it was found that, on a level, the cylinder tractive powers of the Pacific, Mikado, and Mallet locomotives were 29,718, 33,575, 49,095 pounds, respectively, when the velocity was uniformly 10 m.p.h. and the locomotives each burned 4000 pounds of coal per hour. The several engine resistances at 10 m.p.h. are easily computed from Table XXII and are tabulated below. The net values, or the draw-bar pulls, are plotted

ENGINE CHARACTERISTICS (At velocity $V = 10$ m.p.h.)	PACIFIC 4-6-2 (lb.)	MIKADO 2-8-2 (lb.)	MALLET 2-8-8-2 (lb.)
Cylinder tractive power on level	29,718	33,575	49,095
Engine resistance on level	2,205	2,648	4,864
Draw-bar pull on level	27,513	30,927	44,231
Draw-bar pull on 3-per-cent grade	15,213	18,207	25,631

on the left-hand vertical line of Fig. 162, and in each case are the left-hand ends of the solid lines which show the tractive powers of the locomotives. On a 3-per-cent grade the grade resistances for the locomotives equal 60 pounds per ton, and are 12,300, 12,720, and 18,600 pounds, respectively. This reduces the effective draw-

bar pull approximately 40 per cent in each case. Since this reduction varies uniformly with the grade, we may plot the three values, 15,213, 18,207, and 25,631, on the 3 per cent vertical line and draw straight lines which represent in each case the tractive power of the locomotive at 10 m.p.h. and on any grade within that range.

Assume trains of cars, all averaging 50 tons per car and varying from 10 cars weighing 500 tons to 50 cars weighing 2500 tons. The resistances at 10 m.p.h. on a level grade are given by equation (105),

and may be plotted on the left-hand vertical line of Fig. 162. Grade adds resistance proportional to the grade. For example, on a 0.7-per-cent grade the grade resistance per ton is 14 pounds and for 2500 tons is 35,000 pounds. Adding this to 11,580, the tractive resistance, we have 46,580 which we plot on the 0.7 per cent vertical line. It is indicated by a small circle. Joining the two points gives the resistance line for 2500 tons hauled at 10 m.p.h. The circles on the other lines indicate similar computations. The intersections of these resistance lines with the lines of

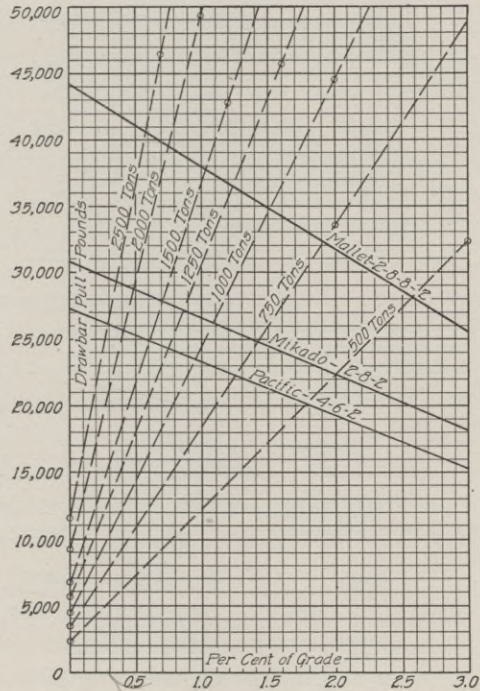

Fig. 162. Curves Showing Effect of Grade on Tractive Power

tractive power indicate the relative power of each locomotive. For example, the 1000-ton train can be hauled by the Pacific locomotive at 10 m.p.h. up a 0.96-per-cent grade, but a Mikado can do the same on a 1.1-per-cent grade, while the Mallet can do it on a 1.52-per-cent grade.

All of these calculations were made on the basis of burning 4000 pounds of coal per hour, which, as before stated, is the



practical limit of what an ordinary fireman can be expected to do for an extended run.

The description of the Mallet locomotive (built by the Baldwin Locomotive Works) stated that its tractive power is 91,000 pounds. A computation of its cylinder tractive power at  $M$  velocity, using 12,000 B.t.u. coal, shows it to be 95,389 pounds. Subtracting the engine resistance (4843 pounds) we would have 90,546 pounds, which is a very fair check, especially as the Baldwin Locomotive Works method of calculation is different.

**195. Acceleration—Speed Curves.** The time required for an engine of given weight and power to haul a train of known weight and resistance over a track with known grades and curvature is an important and necessary matter for an engineer to compute, since the saving in time has such a value as to justify constructive or operating changes which will reduce that time. Fig. 160 shows that the draw-bar pull is very much greater at very low velocities than at the moderate speed of even 15 m.p.h. In spite of the increased resistance at these low velocities the margin of power left for acceleration is also greater and the "speed curve" is really a curve and not a straight line. Its general form may be most easily developed by a numerical example, especially as each case has its own special curve.

*Illustrative Example.* The Mikado locomotive, whose characteristics have already been investigated in article 190 *et seq.*, has draw-bar pulls at various velocities as shown in the tabular form in article 192, to which frequent reference must be made in this demonstration. Assume that this locomotive starts from rest on a 0.4-per-cent upgrade, hauling a train of 14 cars, each weighing 50 tons, and a caboose weighing 10 tons. Then the normal level tractive resistance, by equation (105), equals

$$R = (2.2 \times 710) + (121.6 \times 15) = 3386 \text{ lb.}$$

The grade resistance of the cars will be  $20 \times 0.4 \times 710 = 5680$  pounds. The extra starting resistance will be considered as 6 pounds per ton, or 4260 pounds. These three items total 13,326 pounds. The average draw-bar pull of the locomotive at velocities between zero and  $M$  velocity, which is 6.087 m.p.h., is 34,362 pounds, but this must be diminished in this case by  $20 \times 0.4 \times 157.5 = 1260$

pounds for grade and by  $157.5 \times 6 = 945$  pounds for starting resistance, leaving a net draw-bar pull of 32,157 pounds, excluding the force required for the acceleration of the locomotive. The net force available for acceleration of both the locomotive and the train is  $32,157 - 13,326 = 18,831$  pounds, or prorated, is  $18,831 \div (157.5 + 710) = 21.71$  pounds per ton. Transposing equation (104), with  $V_1 = 0$ ,  $V_2 = 6.087$ , and  $P = 21.71$  pounds, we have  $s = (37.05 - 0) 70 \div 21.71 = 119$  feet, the distance required to attain a velocity of 6.087 m.p.h.

While the velocity is increasing from 1.0  $M$  to 1.2  $M$ , the mean draw-bar pull is  $31,912 - 1260 = 30,652$  pounds, less the accelerative resistance of the locomotive. Subtracting the tractive and grade resistances of the cars, we have  $30,652 - 3386 - 5680 = 21,586$  pounds. Note that there is no longer any starting resistance. The accelerative force in pounds per ton is  $21,586 \div 867.5 = 24.88$ . The distance  $s$  required to increase the velocity from 6.087 m.p.h. to 7.304 m.p.h., is  $(53.35 - 37.05) 70 \div 24.88 = 46$  feet. Similarly the distances required to increase the velocity from 1.2  $M$  to 1.5  $M$ , from 1.5  $M$  to 2  $M$ , etc., are computed as in the accompanying tabular form, p. 270.

. The corresponding distances and velocities have been plotted in Fig. 163. The velocity of 10 m.p.h. is acquired in a little over 300 feet, but it requires nearly 1000 feet to acquire a velocity of 15 m.p.h. and about 2400 feet to raise it to 20 m.p.h. The force, in pounds per ton, available for acceleration is maximum at low velocities, after the extra starting resistance is overcome. As the margin per ton for acceleration becomes less and less, the greater is the distance required to increase the velocity 1 mile per hour—especially through the last increments—up to the velocity at which the net draw-bar pull exactly equals the total car resistance and the velocity becomes uniform. There is an approximation in using *average* draw-bar pulls between the different velocities at which the draw-bar pull has been definitely computed, but the computed distances are practically correct up to 4  $M$  velocity or 24.35 m.p.h. But the computation for the distance required to increase the velocity from 4  $M$  up to 4.58  $M$  is far less accurate if the average draw-bar pull is used. The effective pull at 4  $M$  velocity equals  $12,195 - 1260 = 10,935$ , less the accelerative resist-

VELOCITIES		TRACTIVE FORCES						DISTANCES		TIME	
(Ft. per sec.)	Range (mi. per hr.)	Mean (ft. per sec.)	Mean Drive-Bar Pull, Level (lb.)	Locomotive Resistance Grade Plus Start* (lb.)	Actual Drive-Bar Pull Average (lb.)	Car Resistance Tractive, Grade Plus Start* (lb.)	Difference Available for Acceleration (lb.)	Net Force, per Ton (lb.)	Accelerative (ft.)	Total from Start (ft.)	(Sec.)
0.00	0.00	4.47	34,362	*2,205	32,157	*13,326	18,831	21.71	119	119	27
8.94	6.087	9.75	31,912	1,260	30,652	9,066	21,586	24.88	46	165	5
10.57	7.304	12.00	28,629	1,260	27,369	9,066	18,303	21.10	100	265	8
13.41	9.131	15.63	24,720	1,260	23,460	9,066	14,394	16.59	274	559	18
17.85	12.17	23.05	19,656	1,260	18,396	9,066	9,330	10.76	1,452	1,991	63
28.25	19.26	32.00	14,453	1,260	13,193	9,066	4,127	4.76	3,262	5,253	102
35.76	24.35	38.33	.....	.....	.....	.....	935	.....	11,981	17,234	312

\*The extra starting resistance only applies to the first item.

ance of the locomotive. The tractive and grade resistance of the cars at this velocity is  $3386 + 5680 = 9066$ . This leaves  $10,935 - 9066 = 1865$  pounds available for acceleration of both locomotive and cars. The reduction in tractive force between  $4M$  velocity and  $5M$  velocity (see article 192) is  $12,195 - 8950 = 3245$  pounds. By proportionate interpolation we would then say that the excess force available for acceleration would be exhausted at  $(1869 \div 3245) = .58$  of the interval, or at a velocity of  $4.58M$ , or 27.88 m.p.h. The mean accelerative force is one-half of 1869, or 935 pounds, which is 1.077 pounds per ton of train. The distance, by an inver-

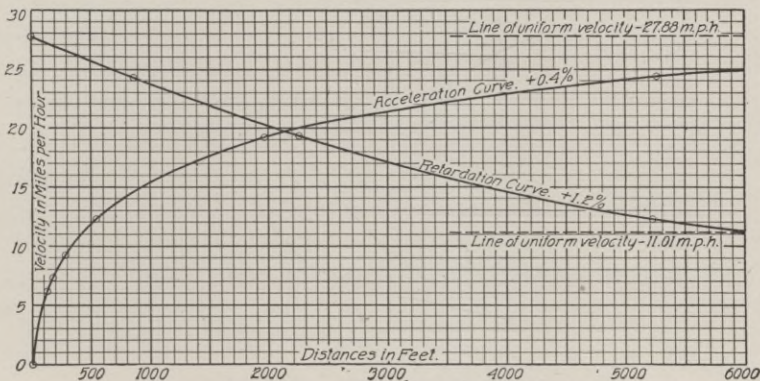

Fig. 163. Time Curves for Mikado Locomotive and Train

sion of equation (104), is computed to be 11,981 feet. Owing to the approximate equality of working force and resistance and the momentary variations in both, the precise point where the acceleration would cease and the velocity would actually become uniform would be very uncertain. Fortunately the inaccuracy is of little or no practical importance and for the purposes of our calculations we may call this last interval 11,981 feet, assuming that the grade is as long as 17,234 feet or 3.2 miles. If the 0.4-per-cent grade continued indefinitely the train would travel at this uniform velocity as long as the locomotive operated on the basis assumed for this problem. Note that Fig. 163 would have to be extended to nearly three times its present length before the time curve would reach and become tangent to the "line of uniform velocity".

DAR  
RADY POLONII  
AMERYKANSKIEJ

VELOCITIES			TRACTION FORCES						DISTANCES		TIME	
(Ft. per sec.)	Range (mi. per hr.)		Mean (ft. per sec.)	Mean Draw-Bar Pull, Level (lb.)	Locomotive Resistance Grade (lb.)	Actual Draw-Bar Pull Average (lb.)	Car Resistance Tractive and Grade (lb.)	Difference Effective for Retardation (lb.)	Net Force per Ton (lb.)	Accelerative (ft.)	Total from Start (ft.)	(Sec.)
40.89	27.88	24.35	38.33	11,260	3,780	7,480	20,426	12,946	14.92	863	863	23
35.76	24.35	19.26	32.00	14,453	3,780	10,673	20,426	9,753	11.24	1,382	2,245	70
28.25	19.26	12.17	23.05	19,656	3,780	15,876	20,426	4,550	5.24	2,975	5,220	129
17.85	12.17	11.01	17.00	.....	.....	.....	.....	1,316	1.517	1,246	6,466	73

**196. Retardation—Speed Curves.** When, on account of grade resistance, the total of tractive and grade resistance is greater than the draw-bar pull, there is retardation.

*Illustrative Example.* Continuing the numerical problem of article 195, assume that, while moving up the 0.4-per-cent grade at a velocity of 4.58 *M*, or 27.88 m.p.h., the train reaches a grade of +1.2 per cent. The grade resistance of the cars will be  $20 \times 1.2 \times 710 = 17,040$  pounds. The tractive resistance will be 3386 pounds, as before, making a total of 20,426 pounds. Interpolating in the tabular form in article 192 for the draw-bar pull at 4.58 *M* velocity, we find 10,326; at 4 *M* it is 12,195, and the mean is 11,260; but from this must be subtracted  $20 \times 1.2 \times 157.5 = 3780$  for grade resistance of the locomotive, leaving 7480 pounds for the net draw-bar pull. The retarding force is  $20,426 - 7480 = 12,946$ ; or in pounds per ton of train, is  $12,946 \div 867.5 = 14.92$ . As before, using an inversion of equation (104),  $s = (777 - 593)70 \div 14.92 = 863$  feet, the distance at which the velocity would reduce to 4 *M*. As before, the other quantities may be computed

and recorded, with less danger of confusion and error, by tabulating them, as given on p. 272.

The mean velocity, when retarding from 4.58  $M$  to 4.0  $M$ , reduced to feet per second, is as before 38.33 feet per second, and dividing this into the distance, 863 feet, gives 23, the time in seconds. The quantities for the reduction in velocity from 4  $M$  to 3  $M$  and from 3  $M$  to 2  $M$  are computed similarly. The level draw-bar pull for 1.5  $M$  is 26,838 (see article 192) and by subtracting 3780, we get 23,058 pounds the actual net pull on the grade. Similarly, the actual pull at 2  $M$  is 18,821 pounds. The increase from 18,821 to 20,426 is  $\frac{1605}{4237} = 38$  per cent of the interval from 18,821 to 23,058 and 38 per cent  $\times .5 = .19$ ; therefore, the actual draw-bar pull just equals the resistance at  $2.0 - .19 = 1.81 M$ , or 11.01 m.p.h. The excess draw-bar pull at 2.0  $M = 23,058 - 20,426 = 2632$  pounds. At 1.81  $M$  the excess is zero and therefore the mean excess is one-half of 2632, or 1316. Dividing this by 867.5, we have 1.517, which is the value of  $P$  in equation (104). Then

$$s = (148.2 - 121.2)70 \div 1.517 = 1246 \text{ ft.}$$

Velocities in miles per hour can be readily converted into velocities in feet per second by multiplying by 1.4667. Averaging the two velocities at the beginning and the end of each period gives the mean velocity; and dividing each of these into the distance for that period gives the time in seconds.

**197. Drifting.** The tractive resistance of the cars of the problem just worked out is 3386 pounds; the locomotive resistance at 20 m.p.h. is 1862 pounds, or a total of 5248 pounds. Variation in velocity will affect this but little. Dividing by 867.5, the total weight in tons, we have 6.05 pounds, the resistance per ton, from which the equivalent rate of grade is  $6.05 \div 20 = .302$  per cent. This means practically that when this train is running *down* a grade which is over .302 per cent it will run by gravity and steam may be shut off. If the grade is much greater than .302 per cent the acceleration on the downgrade may become so great, if the grade is very long, that the velocity may become objectionably high.

*Illustrative Example.* Assume that the limiting safe velocity for freight trains, considering the condition of track and rolling

stock, is 40 m.p.h.; assume that the train we have been considering reaches a 0.4-per-cent downgrade at a velocity of 15 m.p.h. How far down the grade will it run with steam shut off, before the speed reaches 40 m.p.h. and brakes must be applied? There is no question here of variable tractive power since the only motive power is gravity. The resistance is nearly independent of velocity and we will here assume it to be so and utilize Table XVII. At 15 m.p.h. the train has a velocity head of 7.90 feet. At 40 m.p.h. the velocity head is 56.19 feet. The train can therefore drop down the grade a vertical height of  $56.19 - 7.90 = 48.29$  feet before the velocity reaches 40 m.p.h. On a 0.4-per-cent grade the distance required for such a fall is  $48.29 \div .004 = 12,072$  feet. The problem in article 195 assumed that the 0.4-per-cent grade is 17,234 feet or more, and this shows what will happen to the trains moving in the opposite direction.

But it must not be thought that there is no loss of energy during drifting. Even though no steam is used in the cylinders, some is frequently wasted at the safety valve and more is used in operating brakes and in maintaining the brake air reservoir at full pressure. But the greatest loss of heat is that due to radiation, especially in winter, in spite of all the jacketing devices to retain heat. Although the results of the numerous tests which have been made are quite variable, the following approximate averages may be used: the loss due to radiation while standing may be figured as 120 pounds of coal per hour per 1000 square feet of heating surface; while drifting the loss will increase to 220 pounds per hour. The amount of coal used for firing up will be about 510. This is based on the use of 12,000 B.t.u. coal. The better the coal, the less will be used.

*Illustrative Example.* The Mikado locomotive we have been considering has 2565 square feet of heating surface. It will then require about  $2.565 \times 510 = 1308$  pounds of coal to fire up. While drifting down the grade, referred to above, a distance of 12,072 feet, the average velocity is  $\frac{1}{2}(15 + 40) = 27.5$  m.p.h. = 40.3 ft. per sec. and the required time is  $12,072 \div 40.3 = 300$  seconds = 5 minutes = .083 hour. The coal used while drifting down this short run would be

$$220 \times 2.565 \times .083 = 47 \text{ lb.}$$

At this point brakes would need to be applied and the time spent in drifting beyond this point must be computed as an item in the total time spent on the run and also to compute the total amount of coal consumed while drifting. Although this item of 47 pounds is relatively very small, its method of computation is typical of the computation of the several items to make up the total of coal consumed during a trip.

**198. Review of Computed Power of One Locomotive.** It was assumed that it started on a +0.4-per-cent grade with a load of 15 cars weighing 710 tons. After moving 17,234 feet (assuming that the grade was that long) and doing it in 535 seconds, or 8 minutes 55 seconds, the train acquired a velocity of 27.88 m.p.h. and the power of the locomotive would then be sufficient, when burning 4000 pounds of coal per hour, to keep it moving up such a grade indefinitely at that velocity. In case the grade were not as long as 17,234 feet, it would be necessary to compute the velocity where the rate of grade changed and make that the basis for the computation on the succeeding grade. But, assuming that the grade were as long as 17,234 feet, or more, and that the velocity of 27.88 m.p.h. had been acquired, and that the train had run at that speed for some distance—although this does not modify the problem—the train is assumed to reach a still steeper grade, +1.2 per cent. The velocity then begins to decrease and in a total distance of 6466 feet and a total time of 295 seconds, or 4 minutes 55 seconds, the velocity is reduced to 11.01 m.p.h. at which velocity the locomotive is able to make steam fast enough to overcome the higher resistance on the steeper grade. From that point on, assuming that the 1.2-per-cent grade is longer than 6466 feet, the train would continue for the remaining length of that grade at the velocity of 11.01 m.p.h.

As before stated, precision in the above results depends on many factors (such as B.t.u. of coal used, or the actual consumption in pounds per hour) which are somewhat variable. Sometimes the variation of these factors from the values used above is known; sometimes it is unknown and then the accuracy of the results is correspondingly uncertain. But whether accurately known or not, when this method is used, employing the best values for the factors which are obtainable, the method shows a valuable *comparison* of two proposed alinements or grades. In such a com-



parison, any error in the factors will affect both results nearly, if not equally, and the comparative results will still be substantially correct.

**199. Selection of Route.** The preceding articles may be utilized in comparing two routes. If one of the lines is already in operation, the engineer has the great advantage of being able to determine by test exactly what results may be obtained on that line and what factors should be used in computations. It is then only necessary to compute the quantities for the proposed new line. When both lines are "on paper" there is less certainty as to the accuracy of the results, except that the line which is shown to be most advantageous will probably continue to be most advantageous even if the uncertain factors used in the comparison are somewhat changed. Using the methods outlined in articles 195 to 197, there will be computed the behavior of an assumed type of locomotive, hauling one or more types of train load, and passing over tracks having definite grades and lengths. The effect of curves may be disregarded provided that the grades were properly compensated during original construction, and then the rate of grade for the entire length of straight and curved track may be taken as the rate on the straight track. If the rate of grade is actually uniform, even through the curves, then the lengths of curved track must be computed separately and on the basis of a rate of grade equal to the actual rate plus an allowance of .035 per cent for each degree of curve. The behavior of a train from starting to stopping must be computed, making due allowance for each change in condition which will affect the hauling power of the locomotive. The locomotive is assumed to be working at the limit of its steaming capacity, except when drifting with steam shut off on a downgrade, or when brakes are applied, either to prevent objectionably high velocity on a downgrade or to make a stop. The action of brakes during a service stop (as distinguished from an emergency stop) may be considered as a retarding force varying from 10 per cent to 20 per cent of the train weight. Unfortunately brake action is so variable, being directly under the control of the locomotive engineer and varying from zero to the full braking power, that any computation of energy used in operating them or of the effect of the brakes is impracticable except on the basis of arbitrary assumptions such

as the requirement that the brakes are used in such a way that a train will be retarded at a specified rate. The performance of the locomotive over the entire division, the total time required, its velocity in critical places, etc., can be computed. In articles 195 and 196 it was shown that the locomotive considered could haul the particular train considered up a 0.4-per-cent grade at a velocity of 27.88 m.p.h. and maintain such speed indefinitely; also that it could haul the same train up a 1.2-per-cent grade at 11.01 m.p.h. and maintain its velocity indefinitely. This of course means that a much heavier train could be hauled up the 0.4-per-cent grade and that a somewhat heavier train could be hauled up the 1.2-per-cent grade without being stalled, although the velocities in each case would be reduced. There are an infinite number of combinations but there are usually some considerations which narrow the choice. Even after construction is complete these tables may be utilized in a study of the most economical combination of type of locomotive and amount of train load for the track conditions as they may exist.

#### PUSHER GRADES

**200. General Principles of Economy.** It frequently happens that the natural line of a road includes a few grades which are considerably higher than all other grades. These higher grades may be practically hopeless, because a material reduction in them would cost more than it is worth, or more than the general financial condition of the road can afford. A common error is to consider such a grade as the ruling grade and then recklessly permit, at any other place on the road, the adoption of any grade less than this on the ground that it could never limit the operation of trains. But in such cases, it *may* be easily practicable to operate the higher grades with a pusher engine and cut down all lesser grades to such a rate of grade that the "through" engine can haul as many cars on them as two engines can haul on a pusher grade. The economy underlying the method may be seen by a simple illustration which is freed from all details.

Assume that on a division 100 miles long there are two grades of 5 miles each on which pusher engines are to be used; assume that the grades on the other 90 miles are so low that one engine

may haul as many cars on them as two engines can haul on the pusher grades; then by using pusher engines the weight of all heavy trains may be doubled and the heavy freight may be handled in half as many trains. But this economy is effected at the cost of operating the pusher engines. Using single engines for the whole trip, it will require 200 engine-miles to haul a double load. But a single engine can haul the double load over 90 miles of the run, and the same engine with one pusher can haul it up the heavy grades. Each pusher engine will travel 10 miles on each grade, or 20 miles for the two, and the total number of engine-miles for a double load will be 120, instead of 200. And when it is considered that the cost of a pusher engine-mile is far less than that of an ordinary train-mile, as will be shown, the advantages of the method are still more marked.

Of course the full economy of the method is only realized when the maximum *through* grade bears its proper relation to the pusher grade. If the maximum through grade is greater than its proper corresponding value for the pusher grade, then the number of cars is limited by that through grade and the power of the pusher engine is not completely utilized on the pusher grade. Economy of operation requires that an engine should work nearly to the limit of its capacity for as large a portion of the time as possible, and therefore when a heavy engine is compelled to haul a light train over nine-tenths of the route in order that there shall be sufficient power on the other tenth, where alone it is needed, it indicates a lack of economy in the design. It now becomes necessary to develop the proper relation between through and pusher grades.

**201. Balance of Grades for Pusher Service.** *Illustrative Example.* This will be easiest understood by a numerical problem. Suppose that at two or three places on the line it seems impracticable to obtain at a reasonable expense a grade less than 2.10 per cent (nearly 111 feet per mile). But since it seems practicable to make a very much lower grade elsewhere, we will compute the corresponding through grade as the grade to work for. Assume that the through and pusher engines are alike and that, for simplicity in calculation, they are of the Mikado type and of the particular dimensions whose characteristics have already been developed in article 190 *et seq.* The draw-bar pull at  $M$  velocity (6.087

m.p.h.) is 33,403 pounds. But on a 2.10-per-cent grade this must be diminished by  $20 \times 2.10 \times 157.5 = 6615$  pounds, the grade resistance. Two such engines on the 2.10-per-cent grade would have a total net draw-bar pull of 53,576 pounds. Assume that the trains to be hauled are made up entirely of coal cars, fully loaded to 100,000 pounds, and weighing 40,000 pounds, and also a caboose weighing 12 tons. On the basis of equation (105), the tractive resistance of each coal car is 275.6 pounds and that of the caboose 148 pounds. On the 2.10-per-cent grade the total resistance would be 3215.6 pounds for each coal car and 652 pounds for the caboose. The net pull available for coal cars is  $53,576 - 652 = 52,924$  pounds, from which  $52,924 \div 3215.6 = 16+$ , showing that 16 loaded coal cars, besides the caboose, could be hauled up the 2.10-per-cent grade by the two locomotives, and that there would be a considerable margin of tractive power. We must determine the rate of grade on which one locomotive, with a cylinder tractive power of 35,174 pounds at  $M$  velocity (6.087 m.p.h.), can haul a load of 157.5 tons (engine) plus  $16 \times 70$ , or 1120 tons (coal cars) plus 12 tons (caboose), or a total of 1289.5 tons. The tractive resistance of the locomotive (see article 190) is 1771 pounds; for the cars it is  $275.6 \times 16 + 148 = 4558$  pounds, or a total for the whole train of 6329 pounds. The force available for grade is  $35,174 - 6329 = 28,845$  pounds, and  $28,845 \div 1289.5 = 22.4$  pounds per ton, which is the grade resistance on a 1.12-per-cent grade. The net result of the above calculation is that the proposed road may be constructed with 2.10-per-cent grades as pusher grades, provided that the ruling grade for single engines is kept as low as 1.12 per cent.

Sometimes, though rarely, two pusher engines, and even three, may be used on a pusher grade. This might be found desirable on the basis of a combination of grades on each of which the resistance is such that one uniform train load can be handled with the same facility by one engine (or two, or three, or even four). Although the calculations are more complex, they are worked on precisely the same principles as those used above.

**202. Operation of Pusher Engines.** Economy in pusher-engine work demands that the schedule of trains be so arranged that the pusher engine can be kept constantly at work. If there are several short pusher grades separated by several miles of level

track, it means either that a pusher engine must be assigned to each grade, where there may not be enough work to keep it busy, and therefore its daily cost divided by its engine-mileage is abnormally large, or else it must travel uselessly over some intervening stretches of level track in order to be at hand when wanted. Even the time table of the trains must be arranged with reference to the pusher service so that there will not be an accumulation of traffic at the pusher grades at certain hours, with nothing to do at other times. The locating engineer has no concern with the operation of trains, but he should bunch the pusher grades if possible, even spending a little additional money for it if necessary.

On very light-traffic roads, where the trains are so few that the method does not interfere with the schedule, a pusher grade may be operated by a single engine, by taking half of the train up first, leaving it on a switch, and then returning after the other half. This means slow time (which a very poor road can afford); it means a saving of the cost of the extra engine, and also the comparatively costly maintenance of it if the total amount of pusher work is very light. Such a road is probably not blessed with an excess of traffic except during a small part of the year, and the cost and maintenance of a useless pusher for a large part of the year is thereby saved. But it should be noted that even if it is expected to follow this policy, it does not make the slightest difference in the design of the pusher grades or in the ratio of through to pusher grades.

Another possible method of economizing on pusher service, especially on light-traffic roads, where a pusher grade begins or ends near a station yard which is so large that a switching engine is necessary for at least part of the day, is to combine the switching and pusher work. A little ingenuity in planning the schedule will thus enable the pusher engine to utilize its whole time in useful work.

**203. Length of Pusher Grade.** The true length which must be considered in the following calculations is always somewhat in excess of the length of the actual grade as measured on the profile. Although it is sometimes possible, by having the pusher engine approach the train from behind, to accomplish its work without stopping the train either at the top or bottom of the grade, yet

this requires an extra length of track and considerable extra mileage on the part of the pusher engine. For passenger service the assistant engine is always placed in front, and although it is practicable to uncouple the assistant engine at the top of the grade, run it ahead at increased speed, run it on a siding and again clear the main track without stopping the train, it is usually necessary to stop the train at the bottom to couple on. Increased mileage is necessary for this. The stoppage and restarting of a heavy train uses up as much energy as would carry the train several miles on a level track and therefore an increased run by the pusher engine is justifiable if it will save stopping the train. A siding at or near the bottom and top of the grade (and also a telegraph office) is a convenience and almost a necessity for the quick and safe operation of pusher grades, and while they must be clear of the grade it is sometimes more convenient to remove them some distance from the ends of the grade. Each case is a separate problem, but the length to be used in the following calculations must always be the actual run of the pusher engine, which will be somewhat in excess of the actual length of the pusher grade as shown on the profile.

**204. Cost of Pusher-Engine Service.** The cost depends partly on the work done by the engine and partly on mere time. The wages of the enginemen must be paid on a *per diem* basis rather than on a mileage basis, and if the engine does not run many revenue miles, the cost for the miles it does run is increased. In view of the fact that the damage to roadway and track by a locomotive has been estimated to be 2 to 4 times that due to an equal weight of cars, it is evidently approximately true that pusher engines, which are usually of the heavy-freight type, should be charged about the same as the average charge for all trains, for all the items of maintenance of way. According to Table XVI, this should be about 18 per cent of the average cost of a train-mile. Adding the full percentage for engine repairs, fuel, water, lubricants and supplies, signaling and telegraph, but excluding enginemen's wages, we have, according to the figures for 1912, a total of about 40 per cent of the average cost of a train-mile. To this must be added the full *per diem* charge for wages of enginemen and firemen. In 1912, this averaged for the whole United States \$5 per day for enginemen and \$3.02 for firemen, but considering that there has

been an almost uniform increase in these figures from \$3.84 and \$2.20, respectively, since 1902, their values during the next few years are problematical and must be determined for each individual case. There must also be added a charge for the capital cost of the engine. Since the cost of repairs and maintenance has already been included, the initial cost divided by the estimated number of miles in its total mileage life gives a charge per mile which covers the capital cost. If such an engine costs \$20,000 and its mileage life is 800,000 miles, the capital cost per mile is 2.5 cents. But since the pusher engine must run 2 miles for each mile of pusher grade, we must multiply the above computed mileage charge by 2 for each mile of pusher grade.

*Illustrative Example.* A locating engineer may find himself compelled to choose between two policies, which may be illustrated as follows: Resuming the numerical case of article 201, assume that the engineer finds that he can concentrate grading expenditures on certain parts of the line and make a through grade with a maximum of 1.5 per cent, or he can concentrate on other parts of the line and cut down all single-engine grades to 1.12 per cent, leaving two grades of 2.1 per cent whose *effective* pusher-grade lengths (see article 203) are 7 and 8 miles, respectively. Assume that the two methods may be constructed for about equal cost. Which is preferable?

From the calculations of article 201, we find that the drawbar pull at  $M$  velocity on a level is 33,403 pounds and on the 1.5-per-cent grade it is  $20 \times 1.5 \times 157.5 = 4725$  pounds less, or 28,678 pounds. The tractive and grade resistance of the caboose is  $148 + (20 \times 1.5 \times 12) = 508$  pounds, and  $28,678 - 508 = 28,170$  is the force available for the coal cars. The resistance of each car is  $276 + (20 \times 1.5 \times 70) = 2376$  pounds, and  $28,170 \div 2376 = 11.8$ , showing that one such locomotive would be hardly capable, unless by extra forcing, to haul even 12 cars up the ruling 1.5-per-cent grades. The calculations of article 201 show that the revenue train load for the combination of 1.12 per cent through grade and 2.1-per-cent pusher grade is 16 loaded coal cars. Of course the other kinds of traffic should also be considered; but if the passenger traffic were very light and there were only a very few cars per train, it might make no difference, beyond a comparatively harmless reduc-

tion in velocity for a few minutes each and at a few points, whether the grade is 1.5 per cent or 2.1 per cent. For simplicity we will confine the problem to a comparison of these grades on the basis of trains of loaded coal cars. Assume that the division is 100 miles long and that there is a traffic against these grades of 96 carloads of coal per day. For simplicity we ignore all traffic in the other direction. The effect of other details, for or against, must be computed separately and independently. With pusher-engine grades the traffic can be handled in 6 trains; on the 1.5 per cent through grades, it will require 8 trains (or 9). On the 7-mile pusher grade there will be 14 pusher-engine-miles per trip; on the other grade, 16. Then the two pusher engines must run 84 and 96 miles, respectively, per day. Suppose that the average cost of a train-mile on that road is \$1.60 and that we estimate 40 per cent of it, or 64 cents, as the charge per pusher-engine-mile for maintenance of way, engine repairs, fuel, etc. Suppose that the pusher engines cost \$16,000 and that the mileage charge for capital cost is 2 cents. Assume for wages of enginemen, \$5, and for firemen, \$3. Then the daily charge for one engine is

$$84 (0.64+0.02)+5.00+3.00 = \$63.44$$

and for the other engine

$$96 (0.64+0.02)+5.00+3.00 = \$71.36$$

It should be noted that only the charges for wages, repairs, and supplies will be directly apparent. A considerable proportion of the above cost is that due to track maintenance, which is a proper charge but it may be forgotten. The proper mileage cost for through-freight trains, operated at the limit of their capacity, is evidently much greater than that of the *average* train. Assume that the cost of these through-freight trains has been computed as \$2.20 per mile for that road, as against \$1.60 per mile for the average train. Then the comparative costs of the two systems would be:

On 1.5 per cent through grade:	On 1.12 per cent through grade, 2.1
8 trains at \$2.20 per mile, for	per cent pusher grade:
100 miles, per day . . . . . \$1760	6 trains at \$2.20 per mile for
	100 miles, per day . . . . . \$1320
	1 pusher engine (84 miles) . . . . . 63
	1 pusher engine (96 miles) . . . . . 71
	\$1454
\$1760	



If 9 trains, instead of 8, were necessary to haul the traffic, the advantage in favor of the pusher grade would be still greater. On the other hand, each of the 6 trains on the pusher-grade line is heavier than one of the 8 trains of the 1.5 per cent line and therefore we might expect greater injury to the track and that a greater charge for track maintenance or a larger total expense per train-mile would be charged. But, as before stated, the locomotive does the larger part of the damage and the addition of cars makes but little difference. The saving of \$306 per day, or \$95,778 for 313 working days per year, is equivalent, if capitalized at 5 per cent, to a capital expenditure of \$1,915,560. This sum, so far as it is accurate, represents the extra expenditure, if necessary, which would be justified to adopt the pusher-grade plan rather than the other.

#### BALANCE OF GRADES FOR UNEQUAL TRAFFIC

**205. Fundamental Principles.** The volumes or weights of the traffic in each of the two directions on any road are usually quite different and frequently that in one direction is 4 or 5 times that in the other. The number of through engines passing over the road in each direction each day is necessarily equal, and, unless some engines run "light", the number of trains must be the same. The number of passenger cars must be the same, and, in the long run, even the number of freight cars must be the same. But if the weight of the freight is very largely greater in one direction than in the other, the cars will run nearly or quite full in one direction and nearly or quite empty in the other direction. The lightly loaded trains will therefore weigh less, and, with the same through engine, can surmount a steeper grade than the heavily loaded train. It therefore becomes justifiable to introduce a slightly heavier grade against the lighter traffic, if economy of construction is thereby obtained.

There are many roads which are not concerned with this phase of grade. When a branch line runs to some terminus in the mountains so that practically all of the heavy grades are in one direction and there are no opposing grades when running out of the mountains (barring a few harmless sags), there is no limitation of trains by grades except in the one direction, and there is

no necessity or object in computing any balance. But the through-trunk lines, especially those running east and west, find that their east-bound traffic is 3 or 4 times their west-bound traffic.

As a single instance, from 1875 to 1880, the ratio of the east-bound ton-mileage to the west-bound on the Pennsylvania railroad was more than 4.5:1. The difference of elevation of the terminals has little or no importance in this case since it is so small compared with the total length of the line, and since any possible effect which it might have had on the grade is utterly lost in the heavy grades in both directions when crossing the mountains. Admitting the justification of a variation in the ruling grade in opposite directions so as to produce a virtual equality in tractive effort, it now becomes necessary to compute the theoretical balance.

**206. Computation of Theoretical Balance.** In spite of the very evident disparity in the weight of the freight traffic in the two directions, there are some equalizing factors, as will be shown:

(1) The locomotive and passenger-car traffic in the two directions are equal.

(2) The passenger traffic in the two directions will be equal. There is a slight exception to this when a road handles a considerable number of emigrants, but the effect of this is absolutely insignificant, especially in view of the further fact that the ratio of dead load to live load is very high with passenger traffic. Considering that even 50 passengers in a car, assumed to weigh 150 pounds apiece, would only weigh 7500 pounds which is but one-sixth of the 45,000 pounds which the car probably weighs, even a considerable variation in passenger traffic each way would not affect the gross load materially.

(3) Empty cars have a greater resistance per ton than loaded cars. The difference may amount to about 4 pounds per ton. Therefore, although a train of loaded cars will require a greater gross tractive effort than an equal number of empty cars, the ratio will not be in proportion to the gross tonnage.

(4) In spite of the best care and regulations on the part of the traffic department, many freight cars will run in the direction of the heaviest traffic either empty or but partly loaded.

(5) In general it is the freight which has the greatest bulk and weight, such as grain, coal, lumber, ore, etc., which is

run from the rural districts toward the cities and manufacturing districts.

(6) The return traffic, which consists chiefly of manufactured products, and which is worth as much as the other, weighs but a small fraction of the other.

*Illustrative Example.* As a simple numerical illustration, assume that it has been determined that on a given east-and-west line the east-bound traffic is 3 times the west-bound traffic. Utilizing some of the data already worked out in article 201, assume that the ruling grade against east-bound traffic is 1.12 per cent, disregarding the pusher grade, and that, as computed, the Mikado engine can haul 16 loaded cars (50 tons load, 20 tons tare) up this grade. This car loading may also apply to one type of box car. The live load on one train (east-bound) is  $16 \times 50 = 800$  tons. One-third of this (for west-bound traffic) is 267 tons, and adding  $16 \times 20 = 320$  for tare, we have 587 tons as the weight of the revenue cars, west-bound. The tractive resistance on a level of these 16 cars is  $(2.2 \times 587) + (16 \times 121.6) = 3247$  pounds. Adding 148 for the caboose and 1771 for the locomotive, we have 5166 as the total tractive resistance, and subtracting this from 35,174 we have 30,008 pounds available for grade. The total train weight is  $157.5 + 587 + 12 = 756.5$  tons. Dividing this into 30,008 we have 39.6 pounds per ton, which is the equivalent of a 1.98-per-cent grade. On the 3:1 basis, the 1.98-per-cent grade against west-bound traffic corresponds to the 1.12-per-cent grade against east-bound traffic.

**207. Estimation of Relative Traffic.** The estimation of the relative volumes of traffic on a road yet to be constructed is usually a matter of sheer guesswork, except as it might be inferred from existing roads which are similar in character. But this problem often forms one of the features of the plans for the improvement of existing lines and in such a case there is an abundance of existing data. Since it concerns only the ruling grades, it affects only those trains which are affected by the rate of the ruling grade. It is unfortunately true that the fluctuations of traffic are such that a ratio which might have been perfect at the time of its computation may become considerably in error for a long period of time, if not permanently. A change in the development of the country may turn an agricultural region into a

manufacturing region or the discovery of vast deposits of coal or ore may result in a considerable and permanent change in the flow of traffic.

The Interstate Commerce Commission report for 1911-12 gives the following as the chief items of freight tonnage:

Bituminous coal.....	525 million tons
Ores.....	139 million tons
Lumber.....	125 million tons
Anthracite coal.....	119 million tons
Stone, sand, and other like articles.....	103 million tons
Grain.....	71 million tons
Cement, brick, and lime.....	62 million tons
Coke.....	62 million tons
30 other headings.....	580 million tons
Total	<u>1,786 million tons</u>

It will readily be seen that the above items only include the heavy, bulky freight. Such an item of manufacture as agricultural implements only weighed 3,399,214 tons, and household goods and furniture but little more. These figures emphasize the statements made above regarding the relative weights of various classes of traffic.

Perhaps the safest general rule is to say that opposite ruling grades should be made equal unless there is a definite reason for making them unequal. The reconstruction of the great trunk lines, on which so much money is now being spent, invariably aims at a lower grade against east-bound traffic than that allowed against the west-bound. The Canadian Pacific railroad had scarcely been completed before there was a reconstruction with this end in view. While it is one of the most uncertain elements to calculate, its justification under certain conditions is unquestionable.

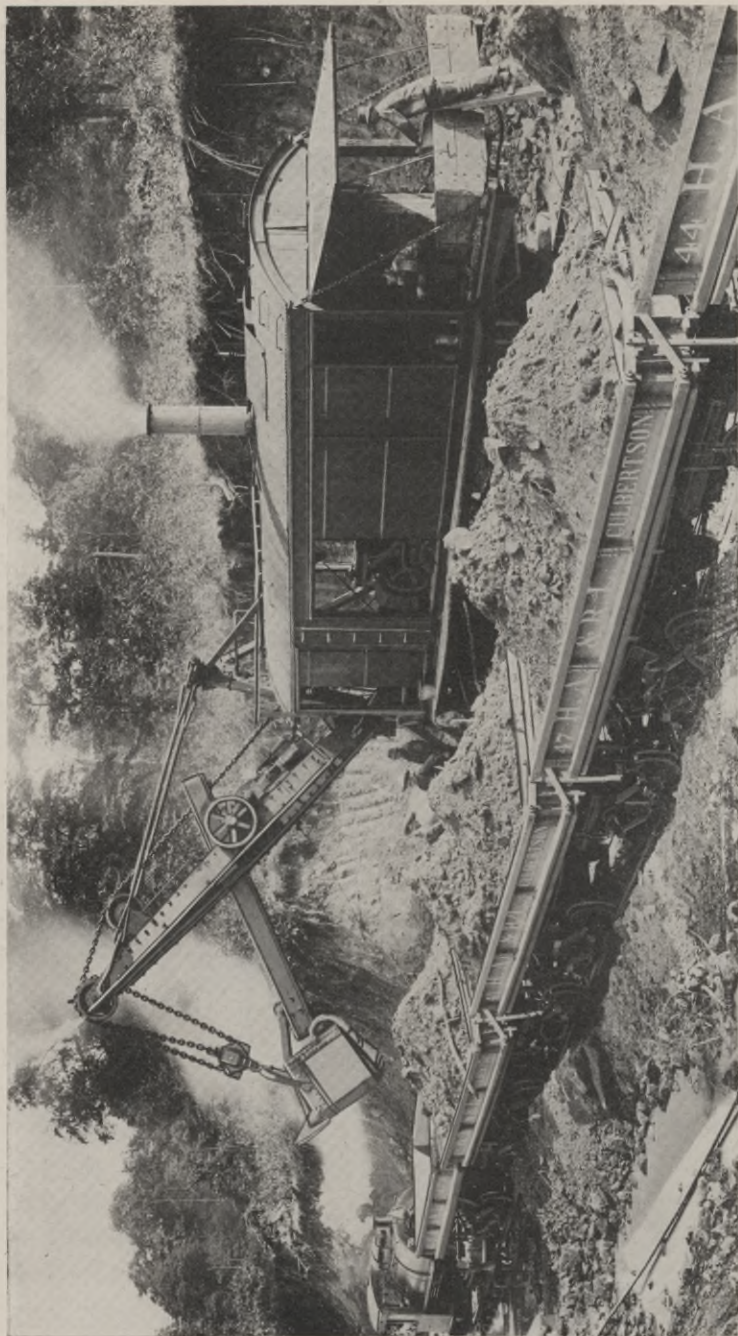

**MAKING A RAILROAD CUT NEAR YOUNGSTOWN, OHIO**  
*Courtesy of Western Wheelbarrow Company, Aurora, Illinois*

# EARTHWORK

## PART I

---

### INTRODUCTION

**Scope of Work.** This article is designed to consider in detail the various kinds of machines employed in excavation and their uses in the construction of highways, railroads, reclamation projects, municipal improvements, etc. Each type of excavator is discussed in sufficient detail to give a clear idea of its construction and field of work. The limitations and cost of operation of each machine for different kinds of excavation under average working conditions are briefly discussed.

This matter, in addition to its uses as a textbook, is serviceable as a brief reference work for engineers, contractors, and others interested in the design and construction of earthwork.

**Fundamental Principle.** Excavation or earthwork is one of the more important factors in nearly all classes of construction work. The fundamental principle of all earthwork is the most efficient use of the best machinery to secure the most satisfactory results, in the least time and at a minimum cost.

**Methods of Excavation.** The proper method to use in any case depends upon several factors: magnitude of work, area over which work extends, nature of soil to be removed, length of haul, cost and availability of fuel, labor, etc., location of work with respect to transportation facilities, etc.

When the job is small, the cost of the installation of the earth-handling plant may be a large proportion of the total cost of the work, and hence it is necessary to use an inexpensive equipment. On a large job, however, the cost of an extensive and expensive equipment can be distributed over a large amount of work, and thus only slightly affect the unit cost. Where the earthwork at any section is small but extends over a considerable area, as in much highway and reclamation work, it is generally most efficiently done with scrapers, graders, or some form of small, portable excavator.

Where the work is of great extent at any section, such as often obtains in the excavation of deep railroad cuts, large waterways, or extensive pits, the use of the larger types of dry-land and floating excavators affords more economical and efficient results.

The light, soft soils do not require any preliminary loosening and can be handled by any form of hand or power tool. Dense, hard soils must first be loosened by plowing or blasting, and the size and weight of the fractured material usually necessitates its removal by some form of power excavator. If the excavated material is to be removed to a considerable distance and used for embankments or other forms of fill, some form of hauling device, such as wagons, trains of cars, or cableway should be used. Where the job is a long distance from a line of transportation, the difficulty and cost of hauling and the scarcity and high cost of fuel, may require the use of small portable types of machinery.

It is evident that the conditions attending earthwork are so variable, and there are usually so many unforeseen circumstances which may affect the progress of a job, that it is impossible to lay down any fixed rules or specify any definite methods.

**General Details of Hand Excavation.** *Loosening.* When the earth is not to be excavated with the larger power machines and is very compact and hard, it must first be loosened. Loam, sand, and soft clay can be excavated with the smaller types of machines without preliminary loosening.

The tools and methods to be used depend upon the magnitude and shape of the work, the character of the soil, the depth of cut, etc. The tools used for loosening are the mattock, the pick, and the plow.

The mattock is a long-handled tool resembling a pickax, but having blades instead of points; the blades being set at right angles to each other. This tool should be used for cleaving, and trimming the surface. The pick is made either with two points or with one point and a chisel-shaped end. Its use is adapted largely to very dense, hard soils such as cemented gravel, hardpan, and loose rock, and in restricted places such as narrow trenches, pits, and corners, which cannot be reached by the plow or power excavators. The amount which can be loosened by a laborer in a 10-hour day varies with the skill and industry of the man, the supervision, character of

the soil, working space, etc., but will average about 12 cubic yards for hardpan and cemented gravel and 20 cubic yards for dense clay.

The plow is the most generally used form of tool for loosening hard, compact soils and is made in several styles for different classes of work. The ordinary mold-board type of plow used on the farm, is adaptable for general use in ordinary soils, but for very hard materials a heavy wedge-pointed plow, known as the pavement plow, should be used. A heavy pavement plow is shown in Fig. 1.

A 2-horse plow with a driver will loosen about 400 cubic yards of average soil per 10-hour day. If the material is a dense clay or gumbo, the daily output with a 4-horse team and three men will be from 150 to 200 cubic yards. If it is assumed that the labor cost for team and plow is \$3.50, and for the plow holder is \$1.50 per 10-

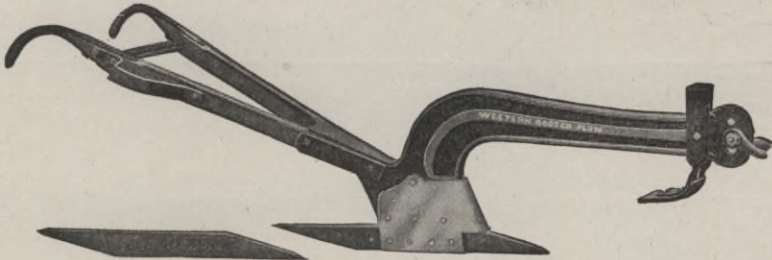

Fig. 1. Typical Hardpan or Rooter Plow  
 Courtesy Western Wheeled Scraper Company, Aurora, Illinois

hour day, the cost of loosening loam and clay will be about  $1\frac{1}{2}$  cents per cubic yard, and for dense, hard clay will be about 4 cents per cubic yard.

*Hand Shoveling.* Shovels are made with either round or square-pointed blades and long or short wooden handles. The round-pointed shovel is more efficient in the removal of stiff, dense soils, and should be used with a short D-handle. The long-handled, round-pointed shovel is the more economical for average soils and should be used where the men are not cramped for working space. A laborer can shovel loose material and elevate it into a wagon or upon a platform at the rate of from 15 cubic yards to 10 cubic yards per 10-hour day for elevations of from 3 feet to 6 feet, respectively. In stiff clay or hard gravel, these quantities will be reduced to from 8 cubic yards to 5 cubic yards, respectively.



## DRAG AND WHEEL SCRAPERS

**Drag Scraper.** The drag, slip, or scoop scraper is a steel scoop or pan with a rounded back and curved bottom. The latter is either provided with runners or reinforced with a thin steel plate,

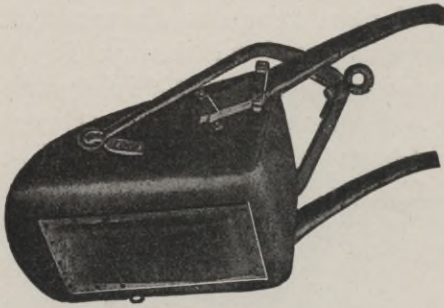

Fig. 2. Drag Scraper  
Courtesy Western Wheeled Scraper Company,  
Aurora, Illinois

known as a "double bottom". Wooden handles are attached to either side near the rear of the pan and are used by the operator in loading and dumping it. A heavy bail with a swivel eye is used for attaching a team of horses. The following tabulation gives the description and cost of the various sizes of ordinary drag scrapers.

Drag Scraper

No.	DESCRIPTION	CAPACITY (cu. ft.)	WEIGHT (lb.)	COST
1	With runners	7	95	\$4.50
2	With runners	5	85	4.25
3	With runners	3½	75	4.00
1	With double bottom	7	100	5.00
2	With double bottom	5	90	4.75

The loading position of a drag scraper is shown in Fig. 2.

The material can be excavated directly with the scraper where the soil is a loose loam, clay, or sand. For harder and more compact soils, the material must first be loosened by a plow. The actual capacities (place measurement) of a scraper will average about one-half the rated capacities given in the tabulation. The pan is rarely filled and the material is loose.

Drag scrapers are efficient for hauls up to 100 feet, and can be satisfactorily used up to 200-foot hauls. A 2-horse team and scraper can move, in a 10-hour working day, the following average quantities of loose material.

## Drag Scraper Service

LENGTH OF HAUL (ft.)	OUTPUT PER DAY (cu. yd.)
25	70
50	60
100	50
150	40
200	35

The following cost of excavation is approximately correct under average working conditions. The figures stated include plowing, loading, hauling, dumping, spreading, supervision, and repairs.

## Cost of Excavation

LENGTH OF HAUL (ft.)	50	100	150	200
Character of Soil:				
Average	\$0.10	\$0.12	\$0.14	\$0.16
Hard	0.13	0.15	0.17	0.19

*Field of Usefulness.* The drag scraper has been used universally in this country during the last quarter of a century in the construction of roads, railroad embankments, and levees. In recent years its field of usefulness has been extended to the construction of broad, shallow canals and ditches, the excavation of foundations for various structures and of areas for reservoirs, borrow pits, etc. The slip scraper is efficient for hauls under 200 feet and for work whose magnitude is approximately less than 50,000 cubic yards.

**Fresno Scraper.** The Fresno or Buck scraper is a long, narrow pan with a rounded back. It is especially adapted to the removal of a wide strip of soil in thin layers, and to spreading it out over a road grade or spoil bank. The following tabulation gives the various sizes, capacities, weights, and costs of a typical make.

## Fresno Scraper

No.	DESCRIPTION	CAPACITY (cu. ft.)	WEIGHT (lb.)	Cost
1	5 -foot cutting edge	18	316	\$27.00
2	4 -foot cutting edge	14	260	25.50
3	3½-foot cutting edge	12	245	22.50

The Fresno scraper is generally operated in groups of from 2 to 10, with a driver for each scraper, and one man to load for the group.

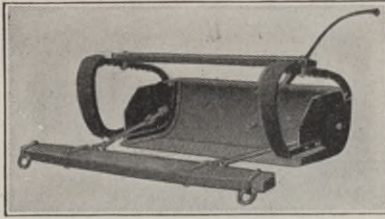

Fig. 3. "Western" Type of Fresno Scraper

The economical haul of this type of scraper is about 300 feet. A 4-horse team is ordinarily used and furnishes a sufficient loading power for ordinary soils. A view of the Fresno scraper in its loading position is shown in Fig. 3.

*Field of Usefulness.* The Fresno scraper is most efficient in the construction of ditches and embankments where the soil is ordinary loam, clay, or sand, and is free from large stones and stumps. For side-hill work this scraper is especially efficient in transporting earth, as it will often push ahead of itself a huge mass of loose material.

In the construction of ditches or canals in a sandy-clay soil under average working conditions, the Fresno scraper will remove 50 to 100 cubic yards with a haul of 70 to 150 feet, during a 10-hour working day, at a cost of from 8 cents to 10 cents per cubic yard.

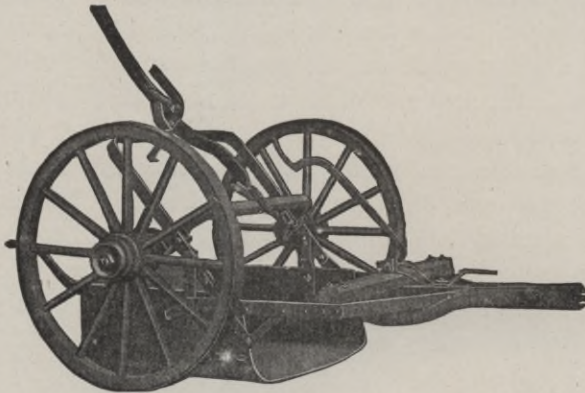

Fig. 4. Typical Wheeled Scraper  
Courtesy Western Wheeled Scraper Company, Aurora, Illinois

**Two-Wheel Scraper.** The wheel scraper consists of a steel box mounted on a single pair of wheels and equipped with levers for the raising, lowering, and dumping of the pan, while the team is in motion. An automatic end gate is sometimes used for the enclosure

of the pan and to prevent loss of material on steep slopes. The following tabulation gives the various sizes, capacities, weights, and costs of a typical make.

Two-Wheel Scraper

No.	CAPACITY (cu. ft.)	WEIGHT (lb.)	COST
1	10	450	\$45.00
2	13	690	52.50
2½	15	700	57.00
3	17	850	60.00

The loading position of a wheel scraper is shown in Fig. 4.

The 2-wheel scraper is an efficient earth mover for hauls up to 800 feet, and more efficient than the drag scraper for hauls over 200 feet. A 2-horse team and scraper can move, in a 10-hour working day, the following average quantities of loose material.

Two-Wheel Scraper Service

LENGTH OF HAUL (ft.)	OUTPUT PER DAY (cu. yd.)
100	60
200	50
300	40
400	30

The following cost of excavation is approximately correct under average working conditions. The figures stated in the tabulation include plowing, loading, hauling, dumping, spreading, supervision, and repairs.

Cost of Excavation

LENGTH OF HAUL (ft.)	100	200	300	400	500	600	700	800
Character of Soil:								
Average	\$0.10	\$0.12	\$0.14	\$0.16	\$0.18	\$0.20	\$0.22	\$0.24
Hard	0.13	0.15	0.17	0.19	0.21	0.23	0.25	0.27

*Field of Usefulness.* The 2-wheel scraper has about the same scope as the drag scraper; being limited to shallow excavation

where the magnitude of the job does not exceed 50,000 cubic yards. The economical operation of the 2-wheel scraper is within hauls of from 200 feet to 800 feet.

Like its prototype, the drag scraper, the wheel scraper is most serviceable in the construction of small railroad embankments and levees, where the continual movement of the teams over the fill is a valuable factor in the compacting of the material. On short hauls of from 200 feet to 400 feet, where the soil is an average loam, clay, or sand, and the cut is shallow, the 2-wheel scraper can be economically used on highway, railroad, and ditch construction, and in the excavation of cellars, reservoirs, pits, etc.

**Four-Wheel Scraper.** This machine is made in two sizes, with pan of  $\frac{1}{2}$ - and 1-yard capacities. The pan of the scraper is hung by chains, on a steel frame which is supported on two 2-wheel trucks. The front wheels are underhung so that short and sharp turns may be made. The pan in the loading position has the cutting edge touching the surface. The pan is operated by 4 levers, which are all within easy reach of the driver or operator who is seated just behind the rear truck, and on the right-hand side of the machine. The motive power is furnished by a team of horses. A snatch team of two or more animals, or a traction engine, is used in loading.

The pan, when filled, is automatically elevated by a sprocket chain while the machine is in motion. The load is dumped through a lever-operated gate in the rear of the pan while the scraper moves over the dump. Fig. 5 shows several 4-wheel scrapers on the construction of reservoir embankments and irrigation canals.

The 4-wheel scraper is about 100 per cent more efficient than the 2-wheel scraper for 200-foot hauls, and this greater efficiency increases with the length of haul. It can be economically used for hauls up to 2000 feet.

*Field of Usefulness.* The 4-wheel scraper is well adapted to highway, railroad, and ditch construction, and in any shallow excavation where the quantity of material to be moved is less than 50,000 cubic yards, and soil conditions do not require the use of a power excavator.

On highway, railroad, and reclamation work, where the cut varies from 1 foot to 3 feet, and the haul is from 400 feet to 1000 feet, 7 to 10 scrapers, loaded by 1 traction engine, can excavate



Fig. 5. View of Four-Wheeled Scrapers on Reclamation Work

from 500 to 800 cubic yards of clay and loam at an average cost of from 10 cents to 15 cents per cubic yard.

## GRADERS

**Two-Wheel Blade Grader.** The simplest form of scraping grader is the 2-wheel grader, which consists of a 2-wheel truck carrying an adjustable blade. The blade is controlled by two levers, which are operated by the driver who is seated at the rear of the machine. The wheels are flanged to prevent lateral slipping of the machine on an inclined surface. The machine weighs 500

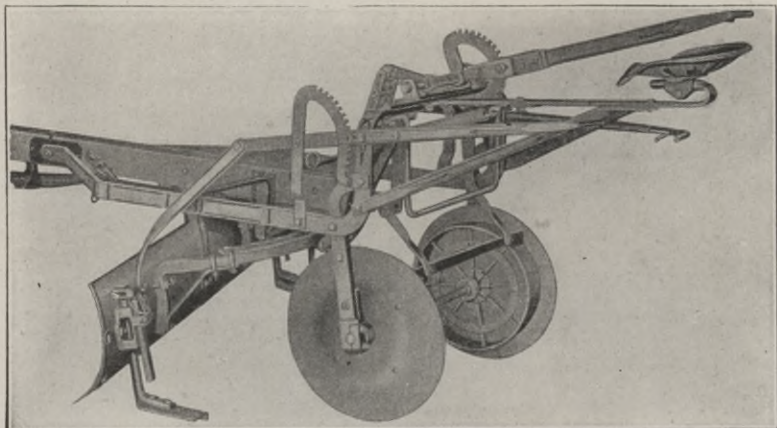

Fig. 6. Two-Wheel Grader  
Courtesy of Baker Manufacturing Company

pounds and costs \$125, f. o. b. factory. A detailed view of a 2-wheel grader is given in Fig. 6.

*Field of Usefulness.* The 2-wheel grader is especially adapted to the excavation of small road and drainage ditches. In soft soil, the average capacity of a machine operated by 2 horses and a driver, is  $\frac{1}{2}$  mile of V-shaped ditch, 24 inches deep, in a 10-hour day.

**Four-Wheel Blade Grader.** The 4-wheel grader consists essentially of an adjustable scraper blade, which is carried by a frame supported on 4 wheels. The blade is controlled by levers, or chains, and can be set at any angle with the direction of draft, raised or lowered to any height or angle, and tilted to the front or rear. The tractive power may be horses or a traction engine; the latter

being more economical in stiff or hard soils. The rear axle is usually made telescoping, so that the frame of the machine may be shifted to either side. This allows one rear wheel to bear against the side of the ditch when making a cut.

The ordinary 4-wheel road grader is made in various forms

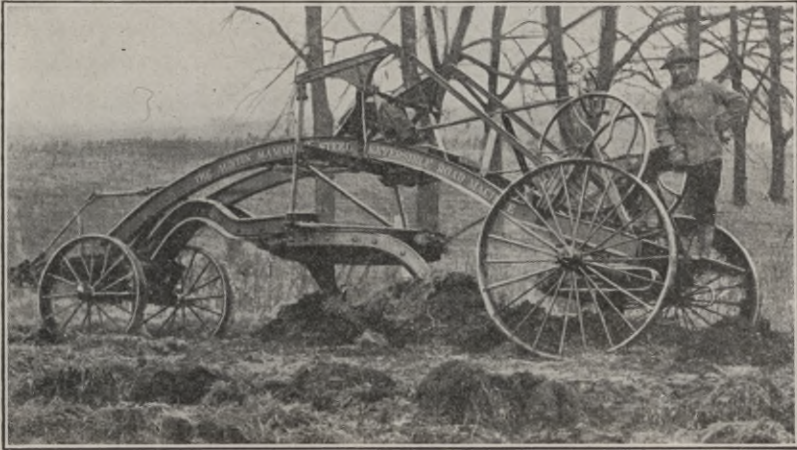

Fig. 7. Large Size Road Grader

*Courtesy of F. C. Austin Drainage Excavator Company, Chicago*

and sizes. The following tabulation gives the sizes, weights, and costs of a typical make.

Four-Wheel Blade Grader

DESCRIPTION	BLADE	WEIGHT (lb.)	COST (f. o. b. factory)
Light	15 in. × 6 ft.	1400	\$135
Standard	15 in. × 7 ft.	2700	225
Large	15 in. × 7 ft.	4000	250
Very large	18 in. × 12 ft.	6100	300

A large-size blade grader on road construction is shown in Fig. 7.

**Reclamation Grader.** A scraping grader, which is especially designed for the construction of ditches is shown in Fig. 8. In this case, 2 graders, drawn by a traction engine, are being used in coördination on road construction. This machine has a much greater latitude in the vertical adjustment of blade and in the lateral or



oblique motion of the wheels of both trucks. The inclined wheels allow for excavation on slopes and offer resistance to the lateral thrust of the earth. This grader is hauled by 12 horses, or by a traction engine, weighs 3800 pounds, and costs \$750, f. o. b. factory.

*Method of Operation.* The 4-wheel blade grader is operated so as to excavate a continuous slice of earth from one side of a cut and move it laterally and gradually by making several trips or rounds of the machine. In road construction, the various steps are



Fig. 8. Scraping Grader Especially Designed for Constructing Ditches

shown in Fig. 9. The grader starts at the side of the road with the blade elevated so that the point will act as a plow. On the second round, with the front and rear wheels in line, the blade is lowered and follows the furrow made on the first round. The third round is made with rear wheels near center of road and the blade more nearly horizontal and swung around so as to push the earth towards the center of the road. The final round is made with the wheels in line and the blade nearly at right angles to the draft and so hung as to level off the material.

*Field of Usefulness.* The road grader can be used efficiently in the construction of roads and ditches. The 2-wheel grader is suitable for the grading up of roads and the excavation of small ditches where the soil is dry and not very hard. The 4-wheel grader is especially serviceable in road construction and the excavation of the upper sections of large ditches or canals. The type of 4-wheel grader known as the "reclamation grader" is especially adapted to side-hill work and the excavation of ditches. The ordinary blade grader of any type is not serviceable in the excavation of wet, soft, or very hard soils.

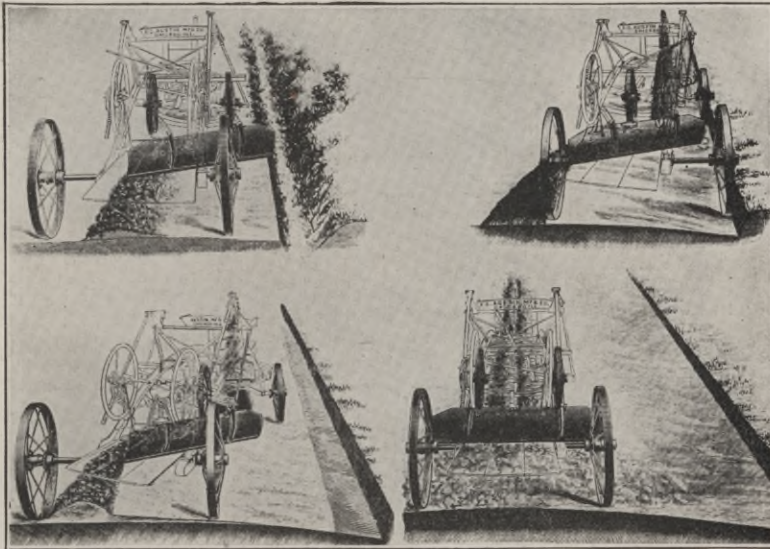

Fig. 9. Diagram Showing Four Stages of Road Construction

The traction engine is the most economical and efficient form of tractive power, and can be used to haul graders in pairs, thus effecting a considerable economy of time and labor, Fig. 8.

*Cost of Operation.* The standard size of 4-wheel blade grader will require the services of 5 horses, or of a traction engine, and of 2 men, at an operating cost of about \$12 per day. In the excavation of ditches and the grading up of roads, for loam and clay, with light grades, the output will average about 1000 cubic yards or about 18,000 square yards of road surface covered during a 10-hour day. The average cost of road construction will vary

from  $1\frac{1}{2}$  cents to  $2\frac{1}{2}$  cents per cubic yard, depending on soil, width of road, size of scraper, depth of cut, etc.

**Elevating Grader.** The elevating grader consists of a frame

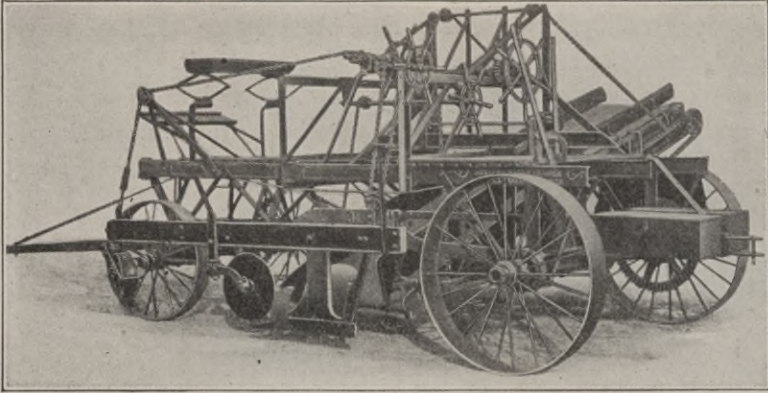

Fig. 10. Elevating Grader Mold-Board Plow  
*Courtesy of Western Wheeled Scraper Company, Aurora, Illinois*

supported on 2 pairs of wheels. From the frame is suspended a plow and a transverse inclined frame, which carries a wide, traveling, endless belt. The plow may be either of the disc or mold-board

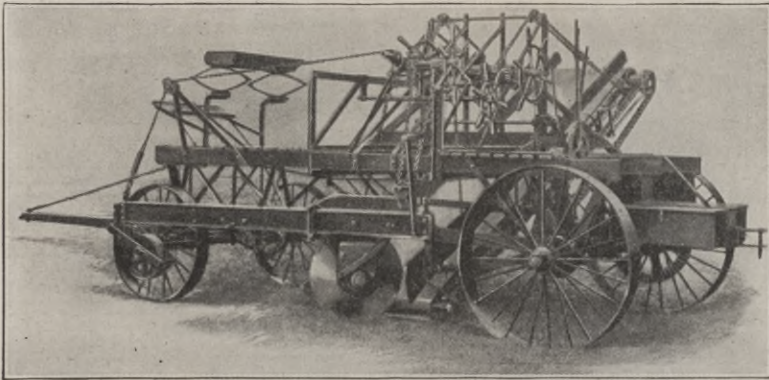
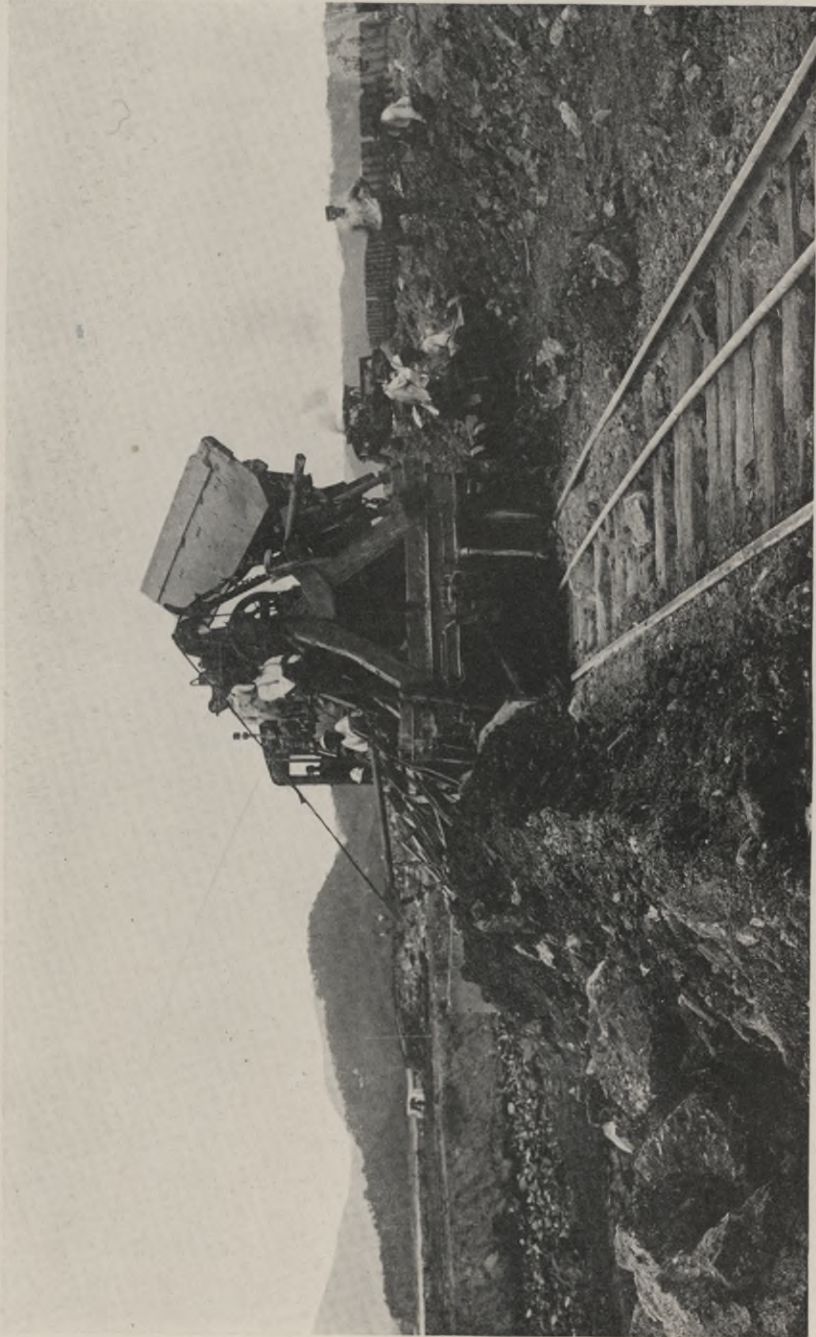

Fig. 11. Elevating Grader with Disc Plow  
*Courtesy of Western Wheeled Scraper Company, Aurora, Illinois*

type. The elevator frame is adjustable both as to length and inclination. The plow is adjustable on an independent frame and loosens the soil which is caught upon the lower end of the inclined



**A SPREADER AT WORK ON THE NAOS ISLAND BREAKWATER**

A wonderfully rapid and efficient method of clearing the dirt and rock away from the tracks to make room for added material or to allow the track to be shifted.

*Courtesy of Panama Canal Commission, United States Government, Washington, D. C.*



elevator. An elevating grader with a moldboard plow is shown in Fig. 10, and one equipped with a disc plow in Fig. 11. The moving belt carries the material to the outer and upper end of the elevator, where it falls upon the spoil bank or into wagons. The elevator side of a grader is shown in Fig. 12.

The elevating grader is generally made in 3 sizes, which are described in the following tabulation.

Elevating Grader

SIZE	CONVEYING RADIUS (ft.)	WEIGHT (lb.)	COST (f. o. b. Factory)
Small	10 to 18	8600	\$ 950
Standard	15 to 21	9400	1000
Large	18 to 30	12000	1400

The motive power is ordinarily furnished by 10 to 16 head of horses or mules, depending on the size of the machine and the char-

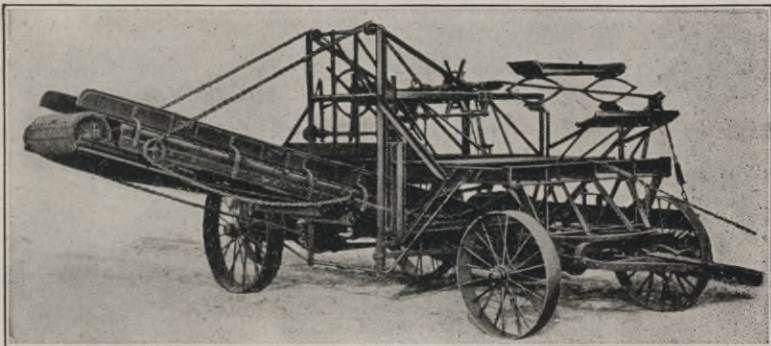

Fig. 12. Elevator Side of Elevating Grader  
Courtesy of Western Wheeled Scraper Company, Aurora, Illinois

acter of the soil. For large jobs and in hard soils, the traction engine is the more economical form of tractive power. In the larger sizes of machines, the elevating belt is often propelled by a 5- to 7-h. p. gasoline engine, mounted on the rear of the frame.

*Cost of Operation.* The standard size of elevating grader will require 12 horses, or a 20-h. p. traction engine, 2 drivers, and an operator, for its efficient operation. The capacity of the machine, working in clay, will average about 800 cubic yards for a 10-hour

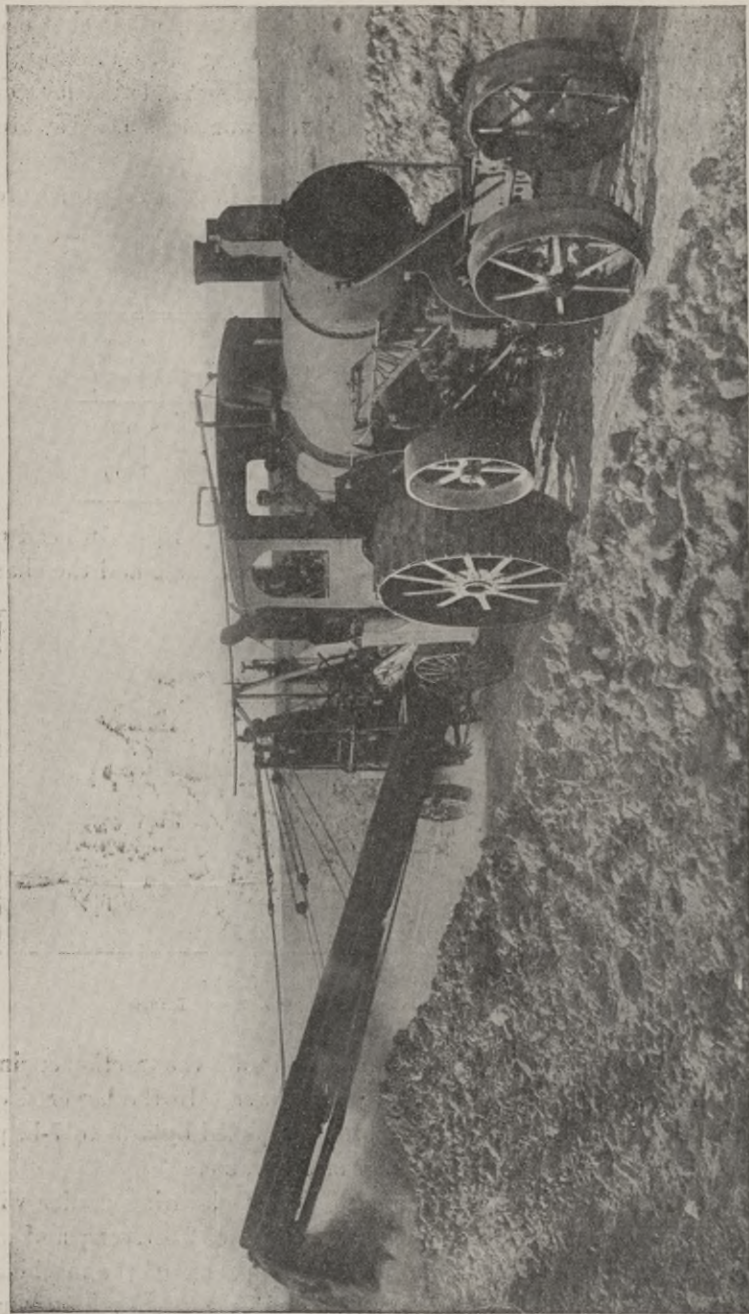

Fig. 13. Elevating Grader Excavating Irrigation Canal

working day. For a haul of about 300 feet, five  $1\frac{1}{2}$ -yard dump wagons will be necessary to keep one grader busy. The cost of operation will vary from 10 cents to 15 cents per cubic yard, depending on soil and labor conditions, the kind of tractive power used, method of disposal of excavated material, etc.

*Field of Usefulness.* The elevating grader is a time-honored and efficient type of excavator in road construction. It is more economical than the blade grader as the excavated material is transported in one operation by the former machine, as compared with several trips required of the latter. The blade grader, however, must be used to finish up the road surface behind the elevating grader. The blade grader must also be used in the grading up of old roads, where the side ditches are narrow or deep.

The soil conditions must be favorable for the efficient operation of the elevating grader. Very loose and light soils cannot be raised by the plow, and wet, sticky soils work with great difficulty. The presence of roots, stumps, boulders, and similar obstructions in the soil render the operation of the grader very unsatisfactory.

In recent years the elevating grader has been used with considerable success in the West, in the excavation of large ditches and canals, especially on irrigation projects. This type of excavator cannot be used to advantage on a ditch having a bottom width of less than 10 feet. A large grader excavating an irrigation canal is shown in Fig. 13.

On railroad work, the grader is not well adapted to the making of cuts. Usually there is not sufficient room in a single-track cut for the operation of the grader with wagons, and unless the width of cut is 35 feet or over there is insufficient space for the wagons to pass the machine, and much of the excavated material has to be rehandled.

## POWER SHOVELS

**Classification.** Power shovels may be classified as to the kind of power used. Formerly all shovels were operated by steam power, but during the last decade, with the universal and economical use of electric power, the electric motor has in many cases replaced the steam engine as the prime mover in their operation. As the steam-operated shovel is the most generally used, that type will be dis-



cussed first. Power shovels may also be classified as to their construction and method of operation as follows:

(1) Those having the machinery mounted on a fixed platform, and the sphere of operation limited to an arc of about 200 degrees about the head of the machine.

(2) Those having the machinery mounted on a revolving platform, and the sphere of operation a complete circle, the center of which is the middle of the machine.

The first class may be divided into three types, according to the manner of supporting the platform: (a) machines mounted on trucks of standard gage, used largely in railroad construction; (b) machines mounted on trucks with wheels centered at other than standard gage, and used in various classes of excavation; (c) machines mounted on trucks with small, broad-tired wheels, and used in railroad, street, basement, and other classes of construction.

The machines of type (a) are generally used for railroad construction. A wooden or steel car body is supported on two 4-wheel trucks of standard make and gage. The crane, which is generally a structural-steel frame, is so arranged that it can be lowered to pass under overhead bridges and through tunnels.

The shovels of type (b) were first built, and are still used on general construction work. They are mounted on a wide wooden or steel framework, or car body, which is supported on 4 small wheels of 7-foot or 8-foot gage. Great stability is thus given to the machine by placing it near the ground with a wide base. This type of shovel can be readily dismantled and transported in sections on cars, wagons, or boats, and is very serviceable for all classes of earthwork on account of its portability and adaptability.

The three types differ principally in their method of support, but otherwise are similar in their details of construction and operation.

### FIXED-PLATFORM TYPES

**Arrangement.** The general arrangement is similar in all makes of steam shovel. On the platform or car body is located the operating machinery and power equipment; the boiler at the rear end, the engines near the center, and the A-frame and crane at the front end, Fig. 14.

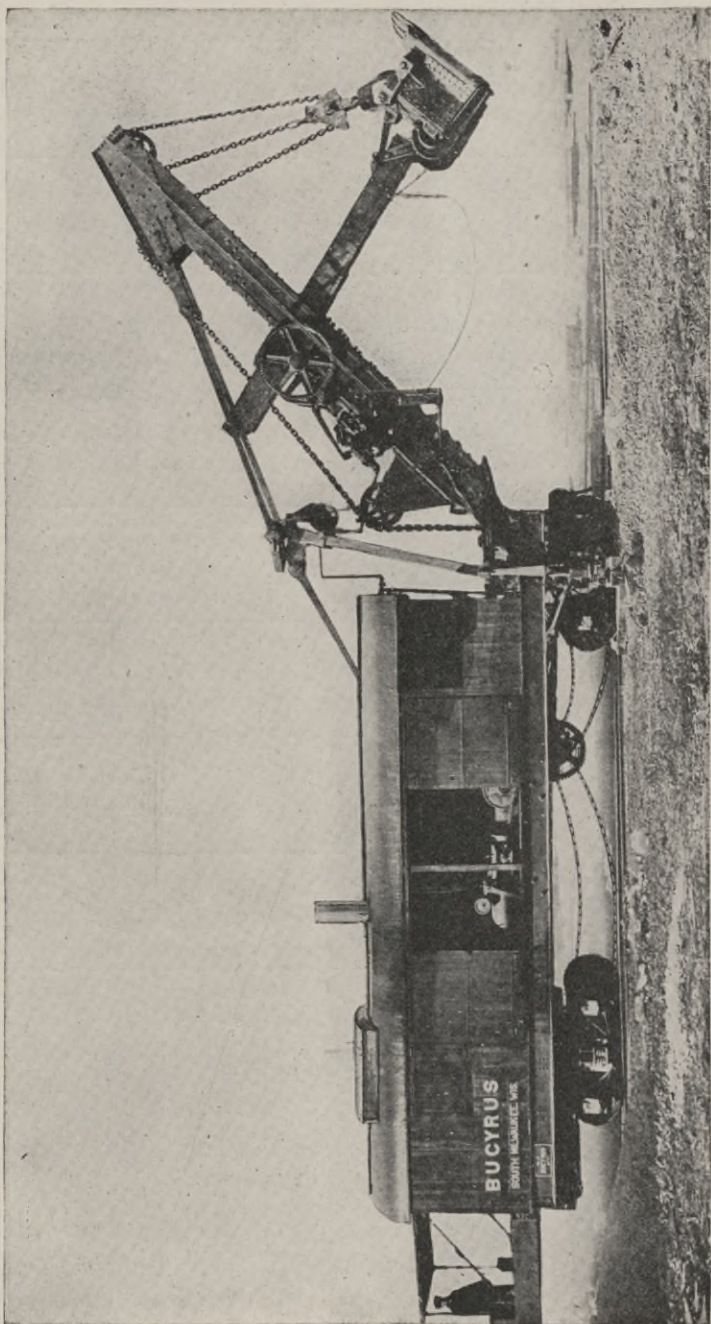

Fig. 14. Typical Fixed Platform Steam Shovel  
Courtesy of The Bucyrus Company, South Milwaukee, Wis.

TABLE I  
 Sizes of a Standard Steam Shovel

TYPE	CHAIN							WIRE-ROPE	
	110 C	100 C	85 C	70 C	60 C	40 R or C	80	45	
Effective Pull on Dipper (lb.)	98,000	91,000	70,000	64,000	56,000	33,000	80,000	45,000	
Capacity of Dipper (cu. yd.)	3½ to 6	3½ to 5	3 to 4	2½ to 3	2½	1½	3 to 5	2½	
Size of Engines (Double-Cylinder)	13"×16" 9"×9" 9"×9"	12½"×16" 8"×8" 8"×8"	12"×15" 8"×8" 8"×8"	10"×14" 7½"×7" 7½"×7"	10"×12" 7½"×7" 7½"×7"	8"×8" 5½"×6" 5½"×6"	12"×12" 9"×9" 9"×9"	10"×10" 7"×8" 7"×8"	
Car Body	44'9" 10'	44'2" 10'	41'4" 10'	36'4" 10'	35' 9'3"	26'3" 7'	42' 10'	36' 10'	
Wheel Base	35'6"	35'10½"	33'5"	30'3½"	28'9"	16'2" 21'1½"	36'	31'	
Width over Traction Wheels						15'			
Height of A-Frame	20'7" 14'6"	19'3" 14'6½"	19' 14'6"	19' 14'6"	18'10" 14'6"	14'1½"	21'8" 15'	19'6" 15'	
Boiler	Loco. 58"×18'3"	Loco. 54"×18'	Loco. 50"×18'	Loco. 44"×18'	Loco. 44"×17'	Loco. 42"×13'6"	Loco. 52"×21'4"	Loco. 46"×20'	
Water Tanks—Total Capacity (gal.)	1800	1600	1600	1500	1500	700	2000	1950	
Weight in Working Order (tons)	120	113	101	87	77	48	101	73	
Shipping Weight	116	101	89	75	65	42	88½	64½	
	121	104	91¾	77¾	67	43	96	71½	

Courtesy of The Bucyrus Company

**Car Body.** The car body consists of a rigid, structural-steel frame, which is often reinforced with durable wooden members to assist the steel shapes in resisting the severe twisting and wrenching strains during operation. On the platform is placed a wooden or light steel frame, which is covered with a sheathing of wood or corrugated steel to form an enclosed car, Fig. 14. Near the front and on each side of the platform are placed jack braces. These are heavy cast-steel brackets, hinged to the platform and carrying screw jacks at their outer ends. During the operation of the shovel, these braces are placed at right angles to the car and prevent the tipping of the front end during the swinging of the crane from side to side.

**Power Equipment.** The power equipment generally consists of a boiler of the horizontal, locomotive type for the larger sizes, or a vertical, submerged-flue boiler for the smaller sizes of shovels, and reversible hoisting, swinging, and thrusting engines. The boiler is fed by a feed pump through an injector, and a working pressure of 125 pounds is used. The older makes of shovel used 1 engine with 3 drums on 1 shaft for the complete operation; but the newer types are equipped with separate, horizontal, reversible, double-cylinder engines for each operation of hoisting, swinging, and thrusting. Chains or wire cables are wound around the drums and attached to the dipper handle and swinging circle and thus transmit the power for the operation of the shovel.

In one well-known type of shovel the engines are mounted directly on the swinging circle and revolve with the crane. This arrangement allows more room on the platform for the boiler, and affords direct transmission of power in hoisting. A diagrammatic view of this type of shovel is shown in Fig. 15.

Table I gives the dimensions, weights, and different capacities of a standard make of steam shovel.

The cost of a steam shovel varies from \$120 to \$165 per ton, the larger the shovel, the less the cost per ton; and the more the total weight, the greater the weight per cubic yard of bucket.

**Excavating Equipment.** The excavating equipment is located at the front end of the car and consists of the boom or crane, dipper handle, and dipper. The crane is made in two sections between which the dipper handle passes, and is generally in the form of a structural-steel frame. The lower end of the boom rests on the

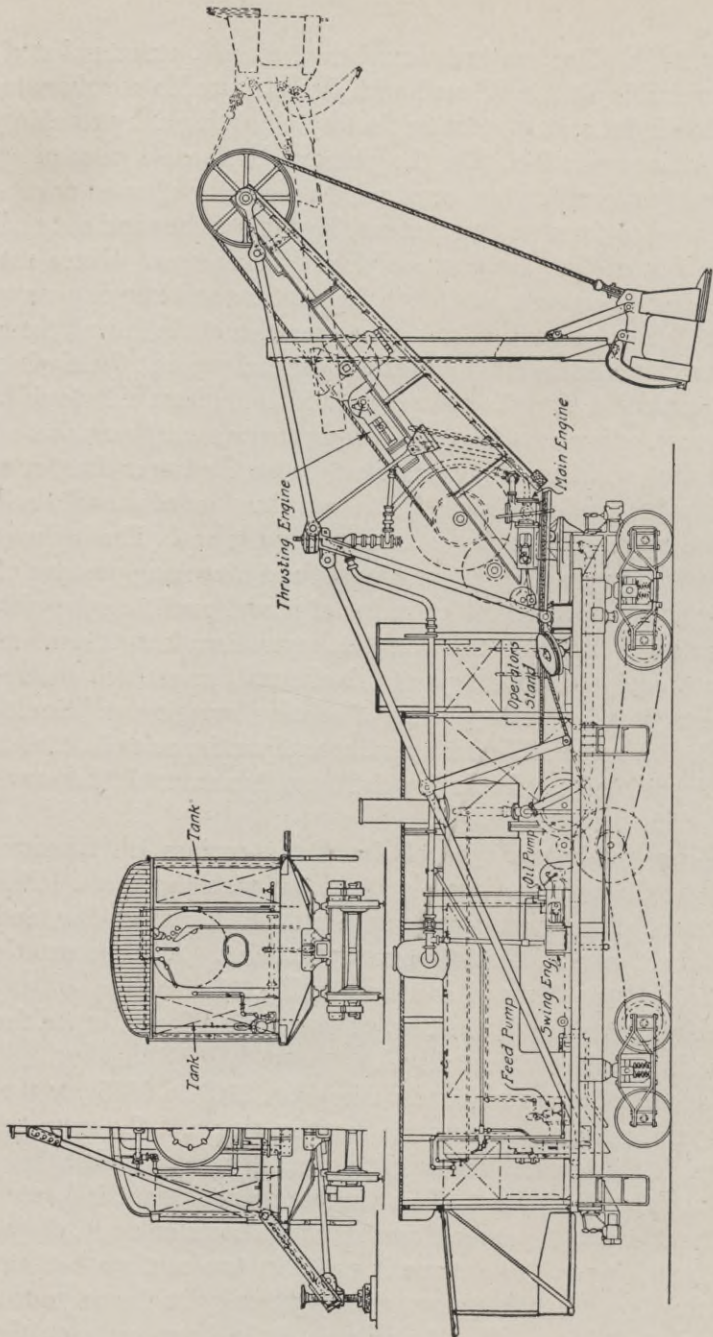

Fig. 15. Diagram of the Atlantic Steam Shovel  
 Courtesy of The Bucyrus Company, South Milwaukee, Wis.

swinging circle which is pivoted to the front end of the platform. The boom revolves with the swinging circle. The upper and outer end of the crane is connected to the top of the A-frame with rods, and has a sheave over which the hoisting cable passes on its course from hoisting drum to dipper handle. The latter carries the dipper at its lower end and moves through the crane and over a pinion which engages a toothed rack on its under side. The dipper handle is usually a single timber of hardwood, reinforced with steel plates or angles. The dipper is made in the form of a scoop with closed sides, open top, and a hinged and latched door at the bottom. It is made of heavy steel plates reinforced at top and bottom with steel bars. The top or front edge is provided with a sharp, heavy-steel cutting edge, or manganese-steel teeth. The bottom of the bucket is of heavy steel, hinged to the rear side and closed by a spring latch on the front side. The operation of the bottom door is controlled by a small line which leads from the door to the side of the boom, where the cranesman stands. Other types of buckets or dippers may be used with the steam shovel, for various classes of excavation, but, as they are largely used for dredging, their construction and use will be described under the section on "Floating Excavators".

**Method of Operation.** A steam shovel of the first class is generally operated by a crew of 7 men; an engineer, a cranesman, a fireman, and 4 laborers. The engineer and cranesman directly control the movements of the machine. The fireman keeps the boiler supplied with fuel and water and sees that the machinery is in good running order. The laborers are generally under the direct control of the cranesman and their duties consist in the breaking down of high banks, assisting in the loading of the dipper, leveling the surface in front of the machine, laying the new track, operating the jack braces, and for general service about the shovel. In rock excavation, from 2 to 6 extra laborers are required for breaking up the rock, mud-capping, etc.

The engineer stands at the set of levers and brakes which are located in front of the machinery. The cranesman stands on a small platform on the right side and near the lower end of the crane. The former controls and directs the raising and lowering of the dipper, the swinging of the crane, and the traction of the whole machine.

The cranesman controls the operation of the dipper, and of the dipper handle, regulating the depth of cut, releasing the dipper from the bank and emptying it into the car, wagon, or spoil bank.

The process of excavation commences with the dipper handle nearly vertical and the dipper resting on the floor of the pit with the cutting edge directed toward the bank. The engineer then moves a lever throwing the hoisting drum into gear and starting the engine. The revolution of the hoisting drum winds up the hoisting line and pulls the dipper upward. Simultaneously, the cranesman starts the thrusting engine and moves the dipper handle forward as the dipper rises. These two motions must be made smoothly and coördinately or the hoisting engine will be stalled and the whole machine tipped suddenly forward. When the shovel has reached the top of the cut or its highest practicable position, the engineer throws the hoisting drum out of gear and sets the friction clutch with a foot brake, thus bringing the dipper to a stop. Immediately, the cranesman releases his brake and slightly reverses the thrusting engine which thus draws back the dipper handle and withdraws the dipper from the face of the excavation.

When the dipper digs clear of the excavation it is unnecessary to release it as described for the last motion. The engineer then starts the swinging engine into operation and moves the crane to the side until the dipper is over the dumping place. With a foot brake he sets the friction clutch controlling the swinging drums and stops the sidewise motion of the crane. The cranesman then pulls the latch rope, which opens the latch and allows the door at the bottom of the dipper to drop and to release the contents. The engineer then releases the friction clutch by the foot brakes and reverses the swinging engine, pulling the crane and dipper back to position for the next cut. As the boom is swung around, the engineer gradually releases the friction clutch of the hoisting drum and allows the dipper to slowly drop toward the bottom of the cut. When near the point of commencing the new cut and as the dipper handle approaches a vertical position, the cranesman releases the friction clutch on the hoisting engine with his foot brake. Thus, as the last part of the drop is made by the dipper, it is also brought into proper position and the length of the dipper arm regulated for the commencement of the new cut. As the dipper drops into place,

TABLE II  
Working Limits of a Fixed-Platform Shovel

TYPE	CHAIN								WIRE-ROPE	
	110 C	100 C	85 C	70 C	60 C	40 R or C	80	45		
Dumping Radius	32'	29'	29'	27'	25'	21'6"	33'	27'		
Height of Dump	17'	17'	16'6"	16'6"	16'	12'	18'6"	16'6"		
Depth of Cut—Shovel Track to Loading Track	10'	10'	9'6"	9'6"	9'	5'	11'6"	9'6"		
Maximum Depth of through Cut	16'	15'6"	15'	14'	13'	7'9"	16'6"	13'6"		
Digging Radius—8-foot Elevation	33'	33'	33'	30'	27'	23'	32'	26'		
Spread of Jack Screws	22'	20'	20'	18'4"	18'	15'	19'	18'		
Height of Boom	33'	28'9"	29'1"	27'0 $\frac{1}{2}$ "	26'9"	21'3 $\frac{1}{2}$ "	33'	27'7"		
Depth of Cut below Rail	6'	5'6"	5'6"	4'6"	4'	2'9"	5'	4'		

Courtesy of The Bucyrus Company



the bottom door closes and latches by its own weight. The time required to make a complete swing depends upon the character of the material and the skill of the operator, but under ordinary conditions this should average between 20 and 40 seconds.

After the entire face of the cut has been removed within reach of the dipper, the shovel is moved ahead. When the shovel moves on a track, a new section of track is laid ahead of the section on which the machine rests. The laborers release the jack screws of the braces, and the engineer throws the propelling gear into place, starts the engine, and the shovel moves ahead 3 to 5 feet. The jack braces are then set into position, the wheels are blocked, and the shovel is

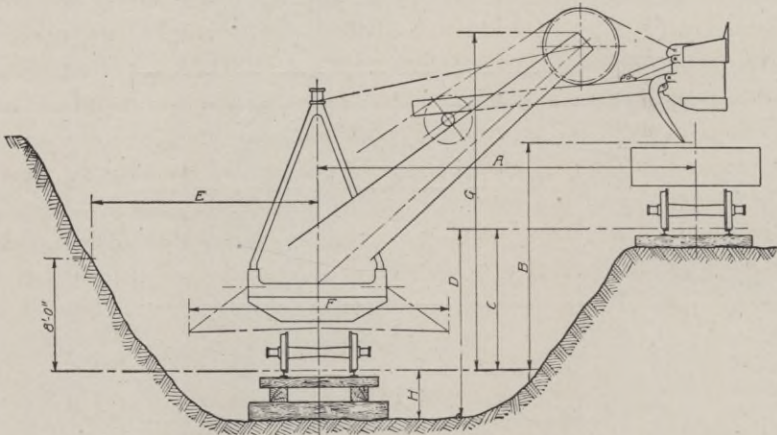

Fig. 16. Diagram of Limitations of Atlantic Steam Shovels

ready for another cut. The maximum width of cut depends upon the size of shovel, length of crane, height of face, etc., and varies from 15 feet to 30 feet. The shovel may cut on a level or slightly descending grade and by working back and forth on different levels may excavate a cut of almost any depth and width.

The steam shovel of the fixed-platform class will excavate any material except solid rock, which must first be blasted down and broken up into pieces small enough for the dipper to handle. The excavated material may be dumped into and carried away by: (1) dump wagons, hauled by teams or by traction engines; (2) dump cars holding from  $1\frac{1}{2}$  to 6 cubic yards, drawn by horses or dinkey locomotives over narrow-gage track; and (3) dump cars of large

size, from 4 to 12 cubic yards, or gondola or flat cars, hauled by large-sized locomotives over standard-gage track.

The dimensions and working limitations of a well-known make of steam shovel of this class are shown in Fig. 16 and Table II.

The values for "Digging Radius at 8-foot Elevation", given in Table II, are theoretical figures which are generally not realized in practice. It would be conservative to use values of from 60 per cent to 80 per cent of those given in the table for actual working conditions.

The output of a steam shovel depends on its size, the character of the material to be excavated, the efficiency of the crew, climatic conditions, location of material with relation to the shovel, relation of shovel to point of dumping, efficiency of wagon or car service, etc. When working under favorable conditions, the maximum working capacity of a shovel will average about one-half of its theoretical capacity as rated by the manufacturers. A shovel is generally in actual operation about 40 per cent of the working time. The remainder of the time is spent in waiting for cars or wagons, and delays for repairs, coaling, watering, oiling, etc. The log of efficient shovel operation under favorable working conditions would be about as follows:

OPERATION	TIME (per cent)
Moving shovel	10
Breaking up rock, mucking, etc.	10
Waiting for cars or wagons	15
Repairs	5
Actual loading	60
Total	100

Table III gives the actual output of about fifty shovels, which were in actual operation for several weeks. These records were collected by Mr. R. T. Dana, of the Construction Service Company of New York.

**Cost of Operation.** The cost of operation of a steam shovel depends upon the class of work, the kind of material to be excavated, the size and efficiency of the machine, the peculiar conditions affecting each job, the facilities for removing the material, etc.

*Illustrative Example.* The type of shovel in general use for heavy excavation is a 70- or 80-ton machine equipped with a  $2\frac{1}{2}$ -yard

TABLE III  
Steam Shovel Service

DIVISION	Shovel Size (tons)	Output (cu. yd.)							SUMMARY
		45	55	65	70	75	90	95	
Iron Ore	Observations				7				9
	Maximum				1512				2728
	Minimum				892				1350
	Average				1095				892
Sand and Gravel	Observations	2			3				5
	Maximum	373			3300				3300
	Minimum	360			1602				360
	Average	366			2365				1566
Earth and Glacial Drift	Observations			1	3				5
	Maximum			1065	1426				1426
	Minimum			1065	569				569
	Average			1065	893				963
Rock	Observations			5	16				26
	Maximum			896	1542				1542
	Minimum			264	168				154
	Average			601	682				704
Clay	Observations		1	2	5				10
	Maximum		320	780	1415				1450
	Minimum		320	474	498				320
	Average		320	627	1064				870
General Summary	Observations	2	1	8	34	1	1	8	55
	Maximum	373	320	1065	3300	820	2728	1350	3300
	Minimum	360	320	264	168	820	2728	154	168
	Average	366	320	665	991	820	2728	972	984

dipper. In making a cut for a railroad or large canal, or in opening up a gravel pit, mine, or quarry, the shovel ordinarily makes a through cut and then returns on a parallel cut, dumping into wagons or cars which move along the previous grade at a higher level. A typical

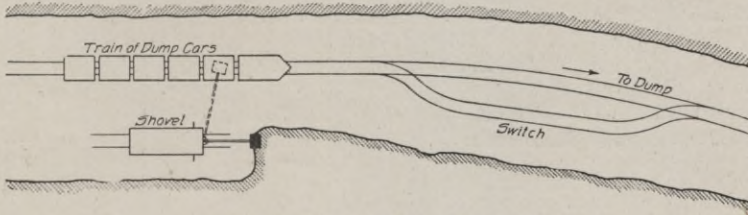

Fig. 17. Diagram of Shovel Operation

arrangement would be as shown in Fig. 17. Under such conditions the cost of operation of a  $2\frac{1}{2}$ -yard steam shovel in the excavation of clay and gravel, for a 10-hour day, would be as follows:

#### Cost of Excavating Clay and Gravel

##### Labor:

1 engineer	\$5.00
1 cranesman	3.50
1 fireman	2.50
$\frac{1}{2}$ watchman, @ \$50 per month	1.00
4 pitmen, @ \$1.75 each	7.00
1 team and driver (hauling coal, water, etc.)	3.50

Total labor, per day \$22.50

##### Fuel and Supplies:

$2\frac{1}{2}$ tons of coal, @ \$4.00	\$10.00
Oil, and waste	1.50
Water	.50

Total fuel cost, etc. \$12.00

##### General and Overhead Expenses:

Repairs	\$5.00
Incidental expenses	2.00
Depreciation (5% of \$12,000)*	3.00
Interest (6% of \$12,000)*	3.60

Total general cost \$13.60

Total Cost of Operation per 10-hour Day \$48.10

Average Daily Excavation (cu. yd.) 1600

Unit Cost of Excavating clay and gravel per cu. yd.,  $\$48.10 \div 1600 =$  00.03

The same steam shovel used in the excavation of a stiff clay or shale would probably require the services of 2 extra laborers at

\*Based on a 20-year life and 200 working days per year.

\$1.75 per day each. The average daily excavation would be 1000 cubic yards, and the cost of operation would be about \$0.05 per cubic yard.

For the excavation of rock which requires blasting, the additional labor and expense would be as follows:

<b>Additional Cost of Excavating Rock</b>	
<i>Labor:</i>	
4 pitmen, @ \$1.75 each	\$7.00
2 laborers, @ \$1.50 each	3.00
	\$10.00
<i>Fuel:</i>	
1 ton of coal, @ \$4.00	\$4.00
<i>Loosening Materials:</i>	
Dynamite, caps, fuse, powder, etc.	\$1.50
	\$15.50
Total Additional Cost of Excavating rock	\$15.50
Total Cost of Operating Shovel in Solid Rock per 10-hour Day	\$63.60
Average Daily Excavation (cu. yd.)	900
Unit Cost of Operation, per cu. yd., $\$63.60 \div 900 =$	00.07

The above statement does not include the cost of transporting the shovel to and from the job, the cost of living and camp expenses, or office and other fixed charges.

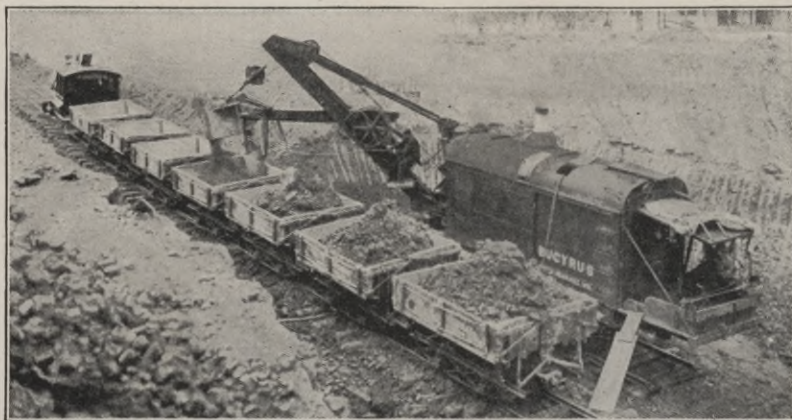
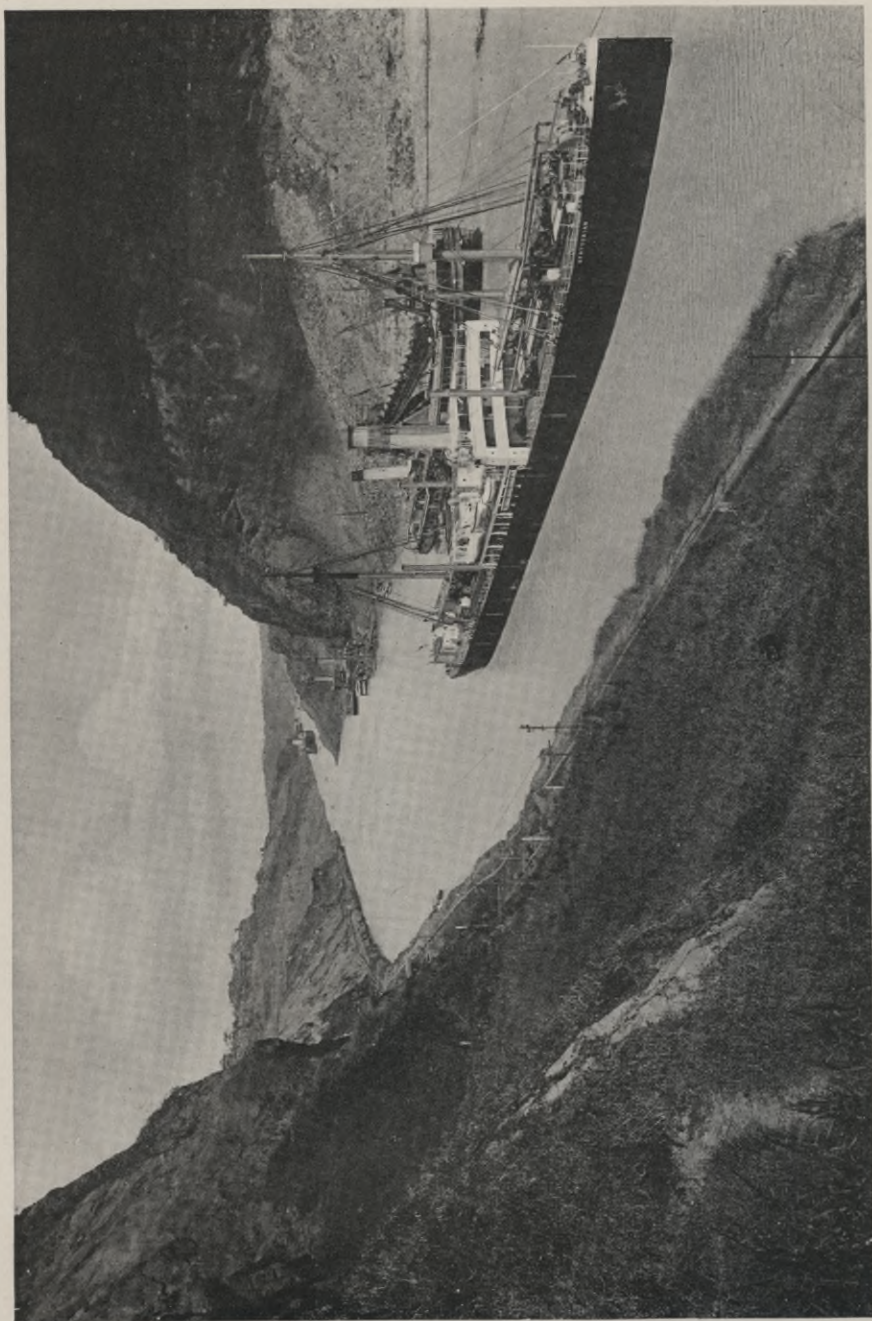

Fig. 18. Bucyrus Shovel Filling Dump Cars with Clay

The cost of the disposal of the excavated material varies from nothing when the material is dumped upon the sides of the excavation (highway or canal construction on a side hill) to 15 or 20 cents





**VIEW OF "CULEBRA" CUT, LOOKING NORTH FROM WEST BANK**  
S. S. "Kentuckian" is passing the Cucaracha Slide. A ladder dredge is at work near the east bank.  
*Courtesy of Panama Canal Commission, United States Government, Washington, D. C.*



Fig. 19. Steam Shovels Loading Dump Cars in Stone Quarry



per cubic yard when the material must be hauled for a long distance and spread. The disposal consists of two operations: the hauling; and the dumping. The cost of hauling depends on the type of conveyance used, number of cars in train, length of haul, etc. The cost varies from 3 to 12 cents per cubic yard. The cost of dumping varies from  $\frac{1}{2}$  cent per cubic yard for wagons to  $1\frac{1}{2}$  cents per cubic yard for cars. Fig. 18 shows a shovel loading a train of side-dump cars with clay. Fig. 19 shows a large size steam shovel loading a train of box cars with limestone in a cement quarry.

### REVOLVING-PLATFORM TYPES

**Arrangement.** There are several makes of revolving shovel which are alike in general arrangement and construction. The

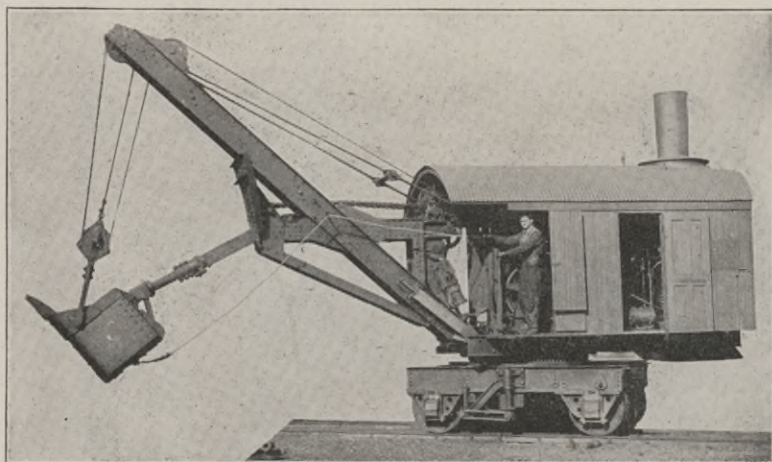

Fig. 20. Type 1 Thew Shovel Mounted upon Car Wheels  
*Courtesy of The Thew Automatic Shovel Company, Lorain, Ohio*

essential features of the revolving shovel are a lower or truck platform and an upper or revolving platform on which are located the operating and excavating equipments. A typical make of revolving shovel is shown in Fig. 20.

**Platforms.** The lower or truck platform is composed of a rectangular structural-steel framework which is strongly braced and riveted. This platform rests on 2 steel axles, the front one pivoted and the rear one fixed in position. On the rear axle is located a

sprocket wheel, which is chain-connected to the engine and thus provides for the traction of the machine under its own power. The turning of the front axle governs the direction of the tractive movement of the shovel. The wheels may be either wide-tired wood or

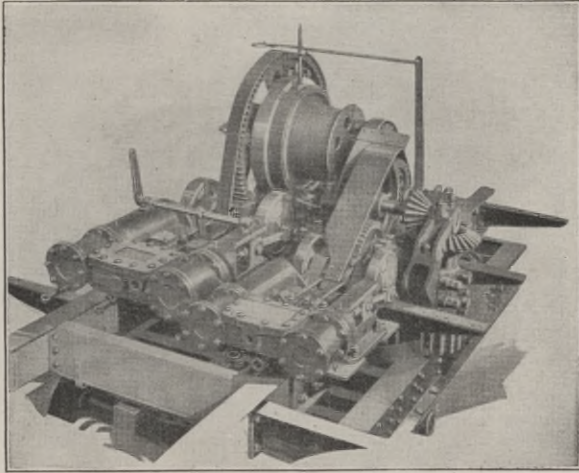

Fig. 21. Details of Thew Hoisting Engine—Horizontal Double Reversing Type

steel, or flanged railroad wheels when the shovel is to operate on a track. Upon the top of the platform is located a large casting which comprises a circular gear, the roller track and the central journal or gudgeon, which supports the upper platform and works.

The upper or revolving frame carries the machinery and lower end of boom and corresponds to the car body of the fixed-platform class of shovel. This platform is a rigid framework of structural-steel members which are strongly braced and riveted. A heavy cast-steel socket is located on the lower side of the platform and rests on the journal of the lower frame. The whole operating mechanism can revolve in a complete circle about the stationary lower frame.

**Power Equipment.** The power equipment of a revolving steam shovel consists of a vertical boiler and independent engines for hoisting, swinging, and thrusting.

The boiler is of the vertical, submerged multi-tubular type, and made to operate under a working pressure of from 100 pounds to 125 pounds. The boiler feed consists of an ejector and a pump,

which can supply water to the boiler while the shovel is in operation. The boiler is located on the rear end of the upper platform.

The engines are all double-cylinder, horizontal, and reversible. The swinging and hoisting engines are located in front of the boiler near the front end of the upper platform. The thrusting engine is located on the upper side of the crane or boom. The hoisting drum is controlled by a friction band which is operated by a foot lever. Fig. 21 shows the swinging and hoisting engines of a well-known make of revolving shovel. The thrusting engine in several makes is of the double, horizontal, reversible type which is used on shovels of the fixed-platform class. One make, the Thew Automatic Shovel, uses a very unique and efficient method of thrusting or crowding the dipper. A carriage or trolley to which is hinged the upper end of the dipper arm, moves horizontally along a track. As the carriage moves forward, the center of rotation of the dipper is changed and produces a prying action. The crowding motion is always in a horizontal direction. The movement of the carriage is controlled by the cranesman, who operates the throttle lever of the crowding engine. The throttle is also connected to a "trip", which automatically shuts off the steam when the carriage reaches either end of the trackway, Fig. 20.

Gasoline power can be used to great economic advantage when coal is high in price and inaccessible. The prime mover is then a gasoline engine which is mounted on the rear of the platform and belt-connected to the operating units.

The upper platform is provided with a housing of wood or corrugated steel for the enclosure and protection of the machinery.

**Excavating Equipment.** The crane or boom is a structural frame of steel, or of steel and wood. The lower end is hinged to the turntable and the upper end is supported by guy rods which extend to the rear corners of the upper frame. The boom is made in two sections and so arranged that the dipper handle may move between them. Upon the upper side of the boom is located the thrusting mechanism.

The dipper handle is of steel, or hardwood reinforced with steel plates. The lower end of the handle is attached to the dipper. Upon the under side of the handle is the steel-toothed rack which engages the pinion of the shipper shaft, which is the gear-operating

mechanism of the thrusting engine. In the Thew shovel, the dipper handle is made of steel and in two sections; the lower member telescopes into the upper section, and the two may be clamped in any position.

The dipper is usually constructed of steel plates and forgings. The cutting edge is usually made of manganese steel and for hard soils is provided with tool-steel teeth which can be removed and replaced when worn out or broken.

**Method of Operation.** A revolving steam shovel is generally operated by a crew of 3 to 5 men; an engineer, a fireman, and 1 to 3 laborers. The engineer controls the operation of the machine. The fireman feeds the boiler with fuel and water and keeps the machinery oiled and greased. The laborers haul coal, assist in the loading of the shovel in hard material, break down the bank, plank the floor of the excavation for the support of the shovel, etc. The engineer stands at the set of levers and brakes which are located near the front end of the upper platform. The method of operation of this type of shovel is similar to that of the fixed-platform class, and the student is referred to the detailed description given under that section. Note, however, that in the case of the revolving shovel, there is no cranesman, and the engineer directly controls the three operating motions of hoisting, swinging, and thrusting.

The revolving shovel will excavate any class of material, except solid rock, which must first be blasted down and broken into pieces of a size which can be handled by the dipper. The excavated material may be dumped into spoil banks along the side of the excavation, or into wagons hauled by horses or traction engines, or into dump cars hauled by dinkey locomotives over a narrow-gage track.

The dimensions and working limitations of an efficient make of revolving steam shovel of the revolving-platform class are given in Fig. 22. In column 1 of the table the class numbers correspond to dipper capacities of  $\frac{5}{8}$ ,  $\frac{7}{8}$ ,  $1\frac{1}{8}$  or  $1\frac{3}{8}$ ,  $\frac{3}{4}$  or 1 (for shale excavation), and  $1\frac{3}{4}$  cubic yards, respectively.

The actual working capacities of revolving shovels depend upon the nature of the material, depth of cut, efficiency of hauling equipment, efficiency of engineer, size, capacity, and efficiency of shovel, etc. In ordinary clay, under average working conditions,

PRINCIPAL DIMENSIONS - THEW SHOVELS - REVISED MAY 1915												
SHOVEL TYPE	A	B	C	D	E	F	G	H	I	J	K	WIDTH OF HOUSE
A-O	5'-0"	13'-6"	21'-0"	15'-0"	10'-0"	18'-9"	18'-6"	9'-4"	3'-3"	12'-3"	2'-8"	7'-0"
O	5'-6"	15'-6"	22'-0"	15'-0"	10'-0"	19'-0"	18'-6"	9'-9"	3'-6"	12'-6"	2'-8"	8'-0"
O-H-L	5'-6"	16'-0"	23'-0"	17'-0"	12'-0"	21'-0"	19'-0"	9'-9"	3'-6"	12'-6"	2'-8"	8'-0"
A-1	6'-0"	18'-0"	24'-0"	17'-0"	11'-0"	21'-0"	19'-6"	9'-11"	3'-10"	13'-6"	4'-0"	8'-10"
A-1-H-L	6'-0"	18'-6"	25'-0"	20'-0"	14'-0"	24'-0"	21'-6"	9'-11"	3'-10"	13'-6"	4'-0"	8'-10"
1	7'-0"	18'-6"	24'-6"	17'-0"	11'-0"	21'-0"	21'-0"	11'-6"	4'-2"	14'-0"	3'-10"	9'-2"
1-H-L	7'-0"	19'-0"	25'-6"	22'-0"	16'-0"	26'-0"	22'-0"	11'-6"	4'-2"	14'-0"	3'-10"	9'-2"
2	8'-6"	19'-0"	21'-6"	15'-0"	10'-0"	19'-0"	18'-0"	11'-6"	4'-7"	14'-0"	3'-10"	9'-9"
3	8'-6"	19'-0"	25'-6"	18'-0"	11'-0"	23'-6"	24'-0"	12'-0"	4'-7"	14'-0"	3'-10"	9'-9"
4	5'-10"	16'-6"	23'-0"	16'-0"	10'-0"	19'-6"	19'-6"	12'-6"	4'-5"	14'-0"	3'-10"	10'-0"

NOTE: TYPES 2-3 AND 4 ARE ALSO BUILT SPECIAL TO MEET CONDITIONS

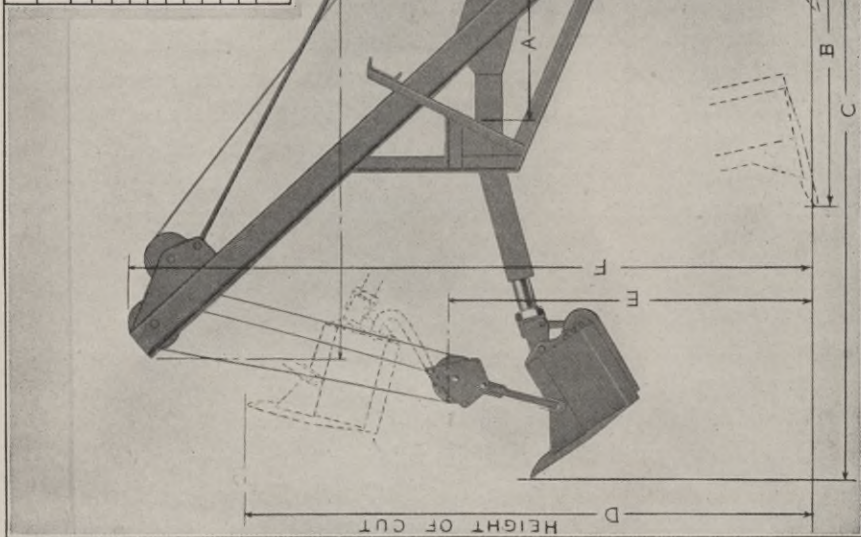

Fig. 22. Diagram Showing Principal Dimensions of Standard Thew Shovels  
 Courtesy of The Thew Automatic Shovel Company, Lorain, Ohio

with a cut of from 5 feet to 10 feet, the output for a 10-hour day should average from about 500 cubic yards, for a  $\frac{5}{8}$ -cubic yard machine, to 1000 cubic yards for a  $1\frac{3}{4}$ -cubic yard machine.

### OPERATING COSTS OF POWER SHOVELS

**Revolving Shovels.** The revolving shovel is one of the most satisfactory and efficient machines for the excavation of dry soils when the required output does not exceed about 1000 cubic yards per day. For light earthwork, where the excavation is widely distributed over a wide area or within narrow boundaries for long

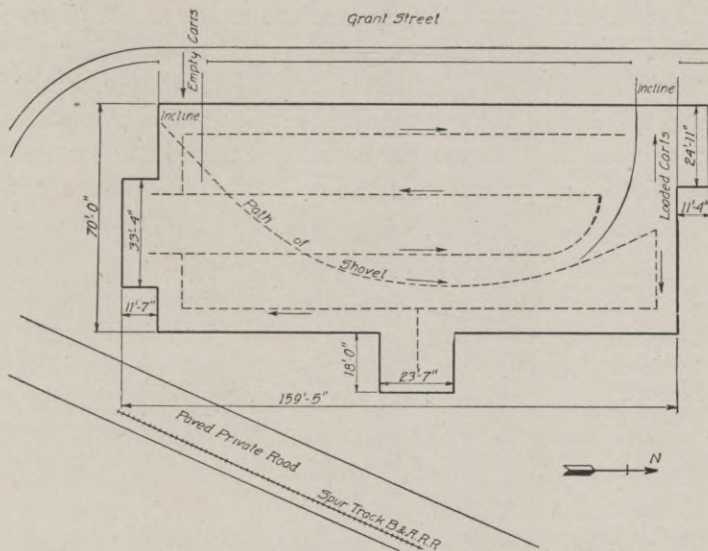

Fig. 23. Excavation Diagram for Reinforced-Concrete Building Showing Location and Path of Shovel

distances, this type of shovel is much more economical than its larger and heavier prototypes of the fixed-platform class. This character of work comprises allotment grading, highway and street grading, railroad construction, cellar and reservoir excavation, sewer trench work, reclamation projects, stripping of quarries, operation of gravel pits, brick yards, etc.

The size of revolving shovel in general use is the  $\frac{3}{4}$ -yard dipper machine equipped with traction wheels. The shovel begins at the surface and works its way down on an easy slope to the final grade.

Then the path of the shovel may be varied to suit the requirements of the job, but usually it assumes the form of a series of parallel lines. At the completion of the work the shovel can pull itself up a temporary incline by means of a cable attached to a "deadman" or anchorage located in the original surface above. The path of a revolving shovel in excavating a cellar for a large reinforced-concrete building is shown in Fig. 23.

*Illustrative Example.* The following example is a typical case of the use of a revolving shovel in quarry, gravel pit, or similar work, where the magnitude of the excavation warrants the installation of a transportation equipment of track and trains of dump cars. The shovel is a  $\frac{3}{4}$ -cubic yard dipper machine mounted on broad-tired wheels which move over heavy planking. The material is a glacial clay fairly free from rock and boulders and varying in depth from nothing to 6 feet. The material is dumped into 6-cubic yard side-dump cars which are hauled by a dinkey engine in trains of 4 cars each. The following cost schedule is based on a 10-hour working day.

#### Cost of Operating a Revolving Shovel

##### Labor:

1 engineer	\$4.00
1 fireman	2.50
1 laborer	2.00

Total labor cost, per day	\$8.50
---------------------------	--------

##### Fuel and Supplies:

$\frac{1}{2}$ ton coal, @ \$4.00	\$2.00
$\frac{1}{8}$ gal. cylinder oil, @ 40c	.07
$\frac{1}{10}$ gallon engine oil, @ 36c	.04
Waste, packing, etc.	.19

Total cost of fuel and supplies	\$2.30
---------------------------------	--------

##### General and Overhead Charges:

Depreciation (based on 20-year life)	\$0.70
Interest, @ 6%	.84
Repairs, and incidentals	1.00

Total fixed charges	\$2.54
---------------------	--------

Total Cost for 10-hour Day	\$13.34
----------------------------	---------

Average Daily Output (cu. yd.)	300
--------------------------------	-----

Unit Cost of Revolving Shovel Operation, per cu. yd.,	
---	--

$\$13.34 \div 300 =$	00.045
----------------------	--------

In cellar and reservoir excavation, where the average cut would be 10 feet and the material loam, clay, and sand, the daily output might be increased to a daily average of 500 cubic yards by the use of sufficient cars or dump wagons to keep the shovel busy during 60 to 70 per cent of its working time. This would make the average operating cost about 3 cents per cubic yard.

In street gradings, where the material is dense and compacted by traffic and the cut shallow or an average of 1 foot, the conditions of successful operation would be more difficult than usual. If the shovel were properly supplied with  $1\frac{1}{2}$ -cubic yard dump wagons, and efficiently operated, the average output for a 10-hour day should be 250 cubic yards. This output would incur an operating cost of about 8 cents per cubic yard.

**Electrically Operated Shovels.** Where electric power is available in large quantities and at a low cost, recent experience has shown the economy of this type of power for the operation of power shovels.

*Advantages of Electric Power.* Where electric power is inexpensive, the cost of operation of an electric shovel is less than that of a steam shovel; with electric power at 3 cents per kilowatt hour, the cost of operation is about one-half that of steam-power machines. Under favorable supply conditions, the use of electric power is desirable and economical for the following reasons: (1) less labor required for operation; eliminates the fireman and the shovel becomes a one-man machine; (2) eliminates the hauling and expense of coal and water; (3) greater economy of power; as power is used only when operating, and steam must be kept up continuously in case of the steam shovel; (4) operation is quieter, steadier, and quicker than that of the steam shovel; (5) eliminates the discomfort of freezing pipes in cold weather and of boiler temperature in hot weather; and (6) eliminates the trouble of banking fires at night and the delay in getting up steam at the commencement of work.

*Electrical Equipment.* The prime mover is the electric motor which may be operated by either direct or alternating-current service. The wound-rotor type of motor is used for direct-current service and the compound-wound motor for alternating-current service. The various sizes of motors for the various capacities of shovels are given in Table IV.



TABLE IV  
 Sizes of Motors for Various Shovel Capacities

WEIGHT OF SHOVEL (TONS)	SIZE OF DIPPER (cu. yd.)	POWER OF MOTORS		
		Hoist (h. p.)	Swing (h. p.)	Thrust (h. p.)
30	1	50	30	30
35	1 $\frac{1}{4}$	50	30	30
35	1 $\frac{3}{4}$	60	30	30
35	1 $\frac{1}{2}$	75	35	35
42	1 $\frac{1}{2}$	75	30	30
65	2	100	35	35
95	3 $\frac{1}{3}$	150	50	50
100	4	200	80	80

The hoist and swing motors are mounted behind their respective engines and are geared to them through reducing gears. The thrust motor is mounted on the upper side of the boom, and geared to the pinions through proper reducing gears.

Shovel service is particularly severe on electric equipment on account of the high power at low speed and the quick starting, stopping, and reversing of the machinery. The sudden stopping of the dipper in the bank, due to cutting too deep, or striking an obstruction, or the sudden stopping of the boom in the act of swinging to one side, tends to stall the motor and burn it out. The use of automatic magnetic controllers and magnet switches has resulted in the efficient control and protection of the motor against such overloads.

On revolving shovels, a single-motor drive has been found to be the more satisfactory on account of the economy in initial cost and the simplicity and flexibility of operation.

The current is taken from trolley wires, or a transformer on a high-power line, and is received through the truck by wire cables. In the case of revolving shovels the current is transmitted to the motor above through copper rings on the truck frame and carbon brushes suspended from the rotating turntable.

*Field of Usefulness.* The electric-power shovel is especially adapted for underground service in mines and tunnels, for plant service in the handling of ores, coal, fertilizers, etc., for excavation in large cities, for electric street-railway construction, and for brick yards, gravel pits, etc. Probably the best field of service for the electric-power shovel at the present time is the use of the electrically operated revolving shovel in the construction of city and inter-

urban electric lines. The track trenching usually requires the shallow excavation of dense, hard material to a uniform grade, and the revolving shovel is the most efficient excavator for this class of work. An electrically operated revolving shovel is shown in Fig. 24.

**Efficiency and Economy of Power Shovels.** The steam shovel is one of the most universally serviceable and efficient of modern excavators. When the soil is sufficiently dry and firm to support



Fig. 24. Electrically Operated Power Shovel

*Courtesy of Westinghouse Electric and Manufacturing Company, Pittsburgh, Pennsylvania*

its weight and the work is of sufficient magnitude to warrant its use, it can be used economically for all classes of earthwork. Hand shoveling has been almost entirely superseded by power-machine shoveling on work where the amount of work will justify the cost of installation of the plant. The relative economy of the two methods may be determined approximately by estimating the cost per cubic yard by hand labor and the same cost by power machine,

including in the total cost by the latter method the items of plant installation, depreciation, interest, and repairs.

A comparison can be made for the excavation of ordinary soil of loam, clay, and sand, under average working conditions, between power-shovel and hand labor. This discussion cannot be exact as there are many indeterminate and variable conditions of soil, labor efficiency, etc., which will affect the results for the peculiar conditions of each case. However, the student is urged to study the method of analysis, as it can easily be applied to the investigation of other methods and of other types of machinery.

*Illustrative Example.* Let us assume a loam and clay soil with few boulders or obstructions; the hauling to be done by 2-yard dump wagons of sufficient number to keep the hand shovelers or power shovel busy; the cut to average 8 feet, and runways to be arranged for the incoming and outgoing teams; the material first to be loosened in the case of hand shoveling.

#### Cost of Shoveling by Hand

##### *Loosening:*

1 plow team, with driver and plow holder;		
Team, plow, and driver	\$3.50	
Plow holder	1.50	
	<hr/>	
Total labor cost, per day		\$5.00
Repairs, depreciation, etc.		1.00
		<hr/>
Total Cost of Loosening		\$6.00
Total Amount of Loosened Material (cu. yd.)	400	
Unit Cost of Loosening Material, per cu. yd., \$6.00 ÷ 400 =		00.015

##### *Shoveling and Loading:*

One man can shovel and load about 20 cubic yards per 10-hour day. Hence the plow should loosen enough material to keep 20 men busy. Loading dump wagons, these men can work efficiently in 4 groups of 5 men each. Each group of 5 men can load on an average 6 wagons per hour or 50 wagons per 10-hour day, allowing for delays.

1 foreman	\$ 3.00	
20 laborers, @ \$1.50 each	30.00	
	<hr/>	
Total labor cost, per day		\$33.00
Repairs, incidentals, etc.		1.00
		<hr/>
Total Cost of Shoveling and Loading		\$34.00
Total Amount of Earth Handled (cu. yd.)	400	
Unit Cost of Shoveling and Loading, per cu. yd., \$34.00 ÷ 400 =		00.085
Total Cost of Hand Shoveling 400 cubic yards		40.00
Unit Cost of Hand Shoveling, per cu. yd., \$40.00 ÷ 400 =		00.10

Assume also a revolving steam shovel equipped with a  $\frac{3}{4}$ -yard dipper and operated by an engineer, fireman, and 2 pitmen. With good wagon service, the average output will be 500 cubic yards per 10-hour day. The shovel will load on an average 30 wagons per hour.

#### Cost of Power Shoveling

##### Labor:

1 engineer	\$5.00	
1 fireman	2.50	
2 pitmen, @ \$1.50 each	3.00	
	<hr/>	
Total labor cost, per day		\$10.50

##### Fuel and Supplies:

$\frac{3}{4}$ ton coal, @ \$4.00	\$3.00	
Oil and supplies	1.00	
	<hr/>	
Total fuel and supplies		\$4.00

##### General and Overhead Charges:

Depreciation*	\$1.00	
Interest†	1.20	
Repairs and Incidentals	1.80	
	<hr/>	
Total fixed charge		\$4.00

Total Cost of Operation per 10-hour Day		\$18.50
Average Daily Output (cu. yd.)	500	
Unit Cost of Power Shovel Operation, per cu. yd.,		
$\$18.50 \div 500 =$		00.037

The above data show that the output is increased by 25 per cent at a reduction in cost of 65 per cent by the use of the steam shovel. The average loading time by hand shoveling was assumed as 10 minutes and for the steam shovel as 2 minutes. This means a saving of about 4 minutes per cubic yard by the use of the steam shovel.

If the teams are paid at the rate of 50 cents per hour for a 10-hour day, the economy in the value of the team time saved, for different shovel outputs, will be as follows:

#### Economy in Team Cost

300 cu. yd. per 10-hr. day, at 3 $\frac{1}{2}$ min.	900 min.	or 15 hrs. @ 50c	\$7.50
400 cu. yd. per 10-hr. day, at 3 $\frac{1}{2}$ min.	1200 min.	or 20 hrs. @ 50c	10.00
500 cu. yd. per 10-hr. day, at 3 $\frac{1}{2}$ min.	1500 min.	or 25 hrs. @ 50c	12.50
600 cu. yd. per 10-hr. day, at 3 $\frac{1}{2}$ min.	1800 min.	or 30 hrs. @ 50c	15.00

\* Based on 5 per cent and 20-year life.

† Based on 6 per cent and 20-year life.

‡ Value of 3 minutes is used as being conservative.

Thus it will be noted that the saving in team time per 10-hour day, on the basis of an efficient shovel operation of 600 cubic yards, is nearly enough to pay for the operating cost of the shovel. Hence it is likewise true that the economy resulting from the efficient use of a power shovel is often equal to the entire cost of shoveling and loading by hand methods. If the job comprised the removal of 45,000 cubic yards and hand shoveling cost 10 cents per cubic yard, the use of a steam revolving shovel would effect a saving sufficient to pay for the cost of the machine.

## DREDGES

### DRY-LAND EXCAVATORS

**Preliminary Discussion.** The steam shovel is not well adapted to earthwork operations on wet or soft soils on account of the concentration of the heavy load of the machine and loaded dipper over a long, narrow area. The crane or boom of the power shovel is short, of heavy construction, and produces great pressure over a small area of base. Hence, for the excavation of soft and wet soils, especially on reclamation projects, it became necessary to devise a machine, similar in construction and operation to the power shovel, but with the load distributed over a wide base and with a long boom for the direct removal of the excavated material to spoil banks adjacent to the excavation. Thus was developed the dredge.

**Classification.** Dredges may be divided into two different classes: dry-land excavators, and floating excavators. The different types of dry-land excavators will be considered in this section and the different types of floating excavators in the following section.

Dry-land excavators are those which move over and operate from the surface of the land. They may be classified as to their construction and method of operation as follows: scraper excavators, templet excavators, wheel excavators, tower excavators, and walking excavators. Scraper excavators may be subdivided into two general classes, as to their method of operation: the stationary dredge with pivoted boom, and the revolving dredge or excavator.

#### STATIONARY SCRAPER EXCAVATOR

During the past decade, the reclamation of thousands of acres of wet land in the Middle West and South, has required the con-

struction of drainage ditches. For this work the stationary dredge, a light portable type of excavator, has been designed particularly for the economical excavation of the smaller sized channels. This machine is stationary only as regards its position during excavation, as it is a traction machine.

**Construction.** The machine consists of a framework of standard structural-steel shapes, supported on two trucks. Each truck comprises a heavy steel axle with two broad-tired steel wheels of 5-foot to 6-foot diameter. Some makes of excavator are supported on caterpillar tractors so as to distribute the load more uniformly

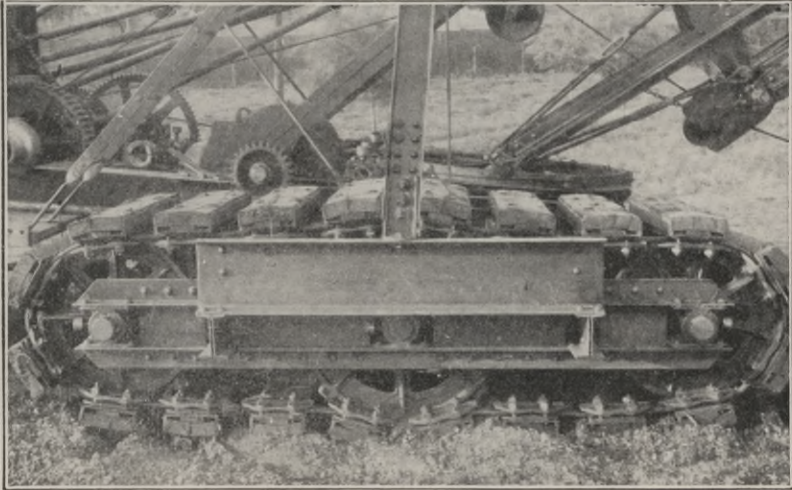

Fig. 25. Caterpillar Tractor

over a larger area of wet soil. As in the view of one of these tractors in Fig. 25, the framework supports the operating and excavating equipment. An excavator loading cars is shown in Fig. 26.

**Operating Equipment.** Near the front end of the platform are placed the operating drums and gears which are belt-connected to a kerosene or gasoline engine mounted near the rear end of the platform. The hoisting and drag-line drums are controlled by friction clutches operated by levers.

These light excavators are operated almost entirely by internal-combustion engines as they are clean, compact, easy to operate, and economical. A 25- to 50-horsepower kerosene or gasoline engine is

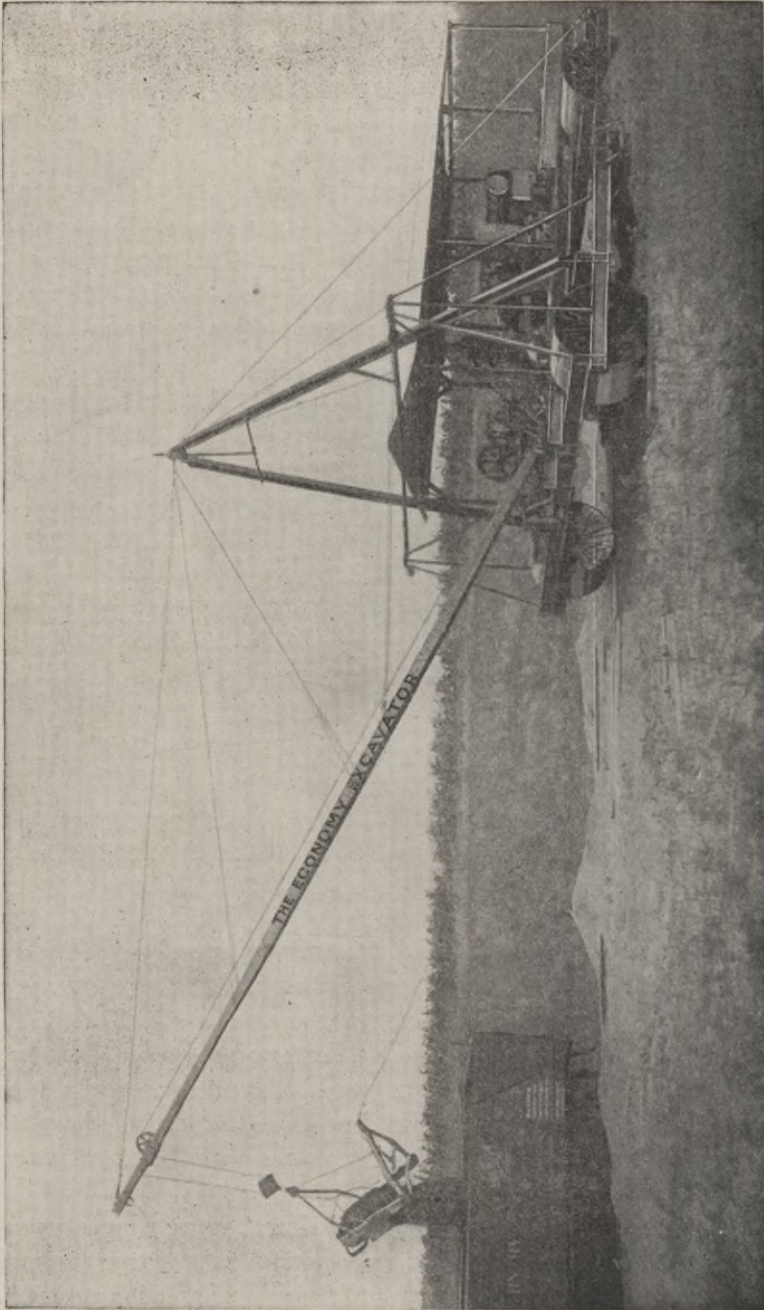
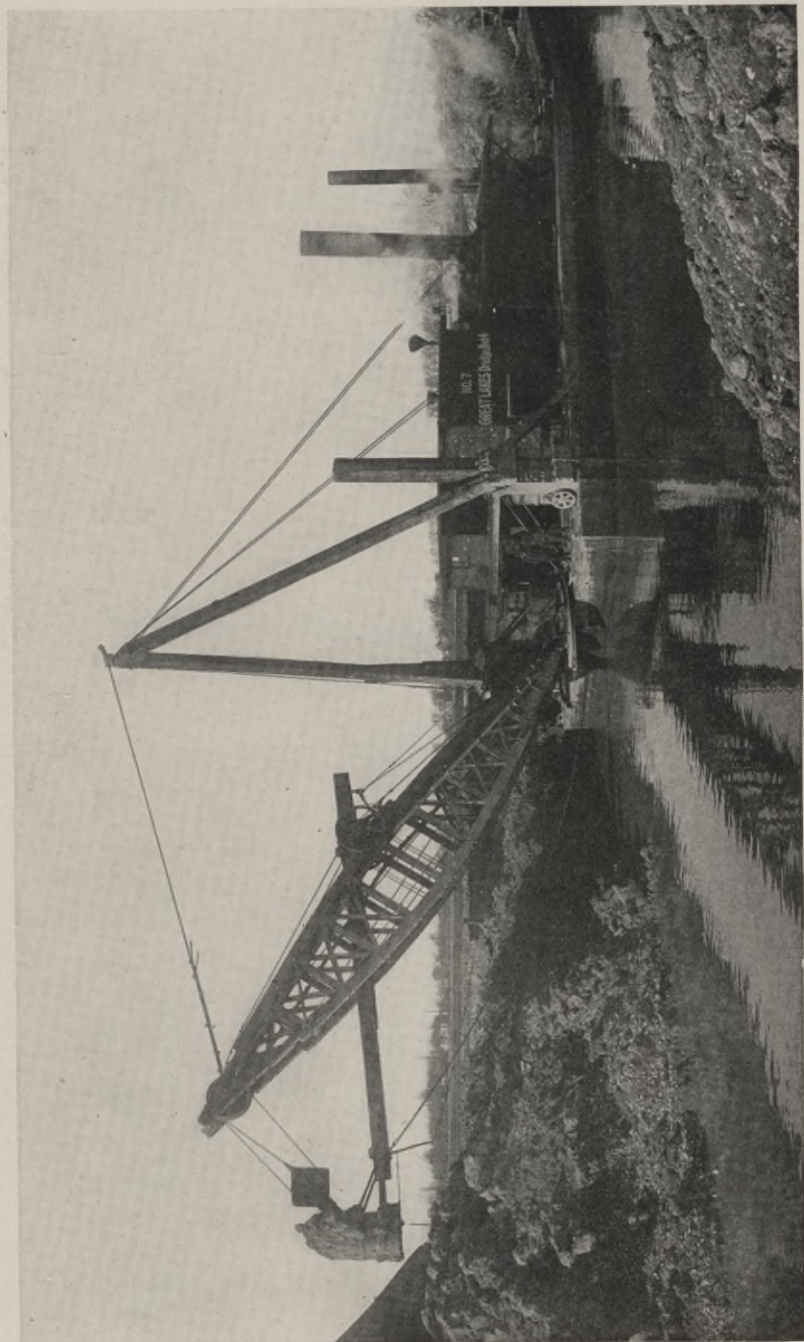

Fig. 26. Light Portable Dry-Land Excavator  
*Courtesy of Economy Excavator Company, Iowa Falls, Iowa*



DIPPER DREDGE AT WORK ON EXTENSION OF CHICAGO RIVER TO EVANSTON DRAINAGE CANAL  
*Courtesy of Great Lakes Dredge and Dock Company, Chicago*





used, depending on size and capacity of machine. With a  $\frac{3}{4}$ -yard bucket and 50-foot boom, a 40-horsepower engine is of sufficient size to furnish the power for the excavation of all classes of soils. The engine is equipped with forced-oil feeder, gear-driven magneto, carbureter, throttle, governor, large oil tank, etc.

**Excavating Equipment.** The excavating equipment consists of the boom, and bucket or scoop. The boom is made of steel channels latticed and braced with truss rods. The lower end rests in a universal joint at the front end of the platform, and the upper end is supported from the A-frame by cables and carries the sheave over which the hoisting cable passes. The bucket is a steel scoop provided with tool-steel teeth for the excavation of dense and hard soils.

**Method of Operation.** One man is required to operate the machine and he stands at the front and controls the machine by a set of levers. The bucket is lowered to the surface by releasing the hoisting line. Then the drag line is hauled in and this pulls the bucket toward the machine, scooping up a thin slice of earth during its progress. When the bucket is near the machine and filled, the boom is swung to one side until the bucket is over the spoil bank, when it is inverted and dumped.

**Field of Usefulness.** The stationary dredge of the light, portable type of construction is rapidly developing a wide field of economic service in earthwork. Being simple and light in construction, the machine can be set up in a short time and can move readily over fairly level ground.

In reclamation work, this excavator is efficient in the excavation of open ditches up to about 40 feet in width. It can be used advantageously for the cleaning out of old ditches which have become silted up. For the excavation and back filling of trenches for drain tile from 24 inches to 42 inches in diameter, the scraper excavator is very efficient.

When highway and railroad work are in wet soils, the light scraper excavator has proved its adaptability in the construction of cuts and embankments. The cuts can be made to any desired side slope and to any depth or width by making one or more trips on the same or different levels. The machine can borrow the material from one or both sides and construct the side ditches in the making of embankments.

The cost of operation will vary from 4 cents to 10 cents per cubic yard for an output of from 1000 to 500 cubic yards per 10-hour day, depending on soil conditions, efficiency of the operator, etc. The machine is generally operated by one man and one or more men are necessary for general service in the pit and about the work.

### REVOLVING EXCAVATOR

**Methods of Mounting.** The most generally used type of dry-land scraper-bucket excavator is the revolving type. These machines may be mounted in three different ways as follows:

(1) On skids and rollers, when the machine travels over the planks laid on the surface. The machine moves ahead by pulling itself up to its bucket, which acts as an anchor.

(2) On trucks, when the machine is mounted on small, steel, 4-wheel trucks. The machine moves ahead as in the case of skids and rollers.

(3) On caterpillar tractors, when the machine is supported on 4 moving platforms which are especially adapted for soft soil conditions and allow the machine to move ahead without the use of planking, tracks, etc.

**Construction.** The essential parts of a scraper-bucket excavator are the substructure, consisting of the upper and lower platforms and turntable; the power equipment; and the excavating equipment. These essential parts are practically the same, as regards their method of operation, for all makes of drag-line excavator. These parts are shown in Fig. 27.

The substructure consists of a lower platform, an intermediate turntable and an upper platform. The lower frame consists of a rectangular framework of structural-steel shapes. The frame is mounted in one of three ways stated above. Upon the upper surface of the lower platform is fastened the track upon which runs the moving circle. In the center is located the lower section of the central pivot.

The turntable consists of a swinging circle, which is a steel frame carrying a series of flanged wheels.

The upper framework or platform consists of steel shapes framed rigidly together. Upon the lower surface of its frame is placed the upper section of the central pivot.

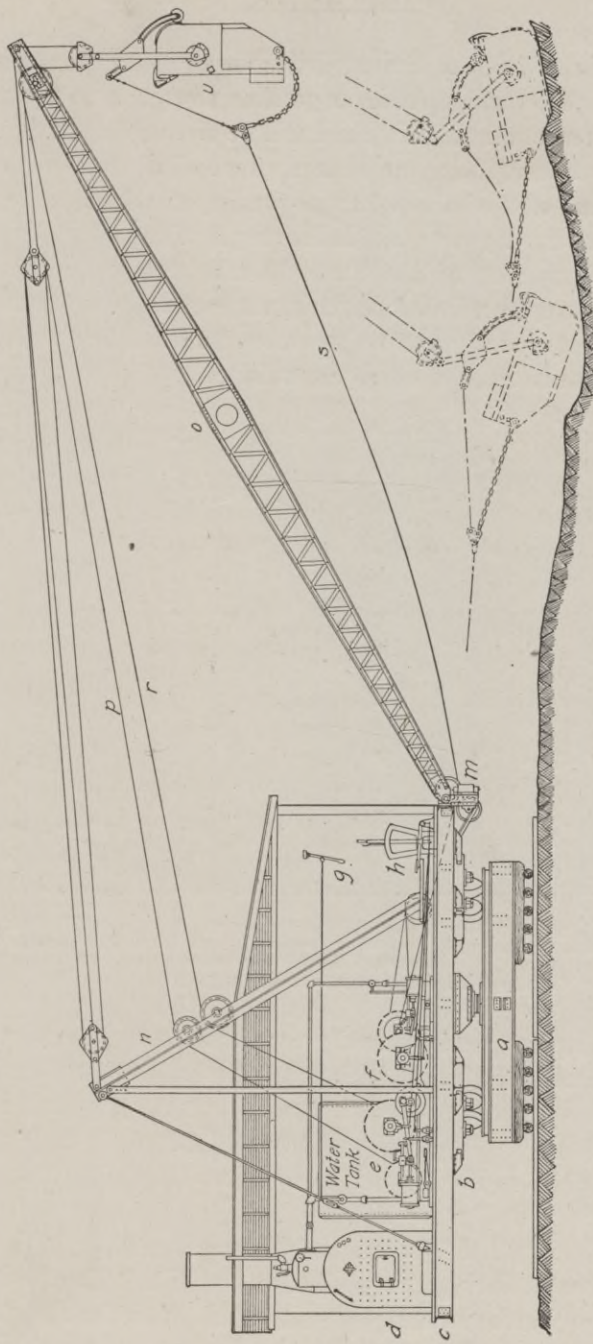

Fig. 27. Detailed View of Scraper Bucket Excavator. *a*, Lower Frame; *b*, Turn Table; *c*, Upper Frame; *d*, Boiler; *e*, Hoisting Engine; *f*, Swinging Engine; *g* and *h*, Operating Levers; *m*, Fair Lead; *n*, A-Frame; *o*, Boom; *p*, Boom Fall Line; *r*, Hoisting Line; *s*, Drag Line; *u*, Bucket.

**Power Equipment.** Scraper-bucket or drag-line excavators may be operated by steam, electric, or gasoline power. The steam equipment is the one generally used and will be discussed first.

*Steam Power.* The power equipment of a steam-power excavator consists of the boiler, steam pump, injector, feed-water heater, main, and swing engines. The boiler may be either of the horizontal, locomotive type or of the vertical, submerged-tube type. The former is the more efficient for hard usage and the latter the more economical of space. A steam pressure of about 125 pounds is ordinarily maintained under average conditions. A steam pump of the

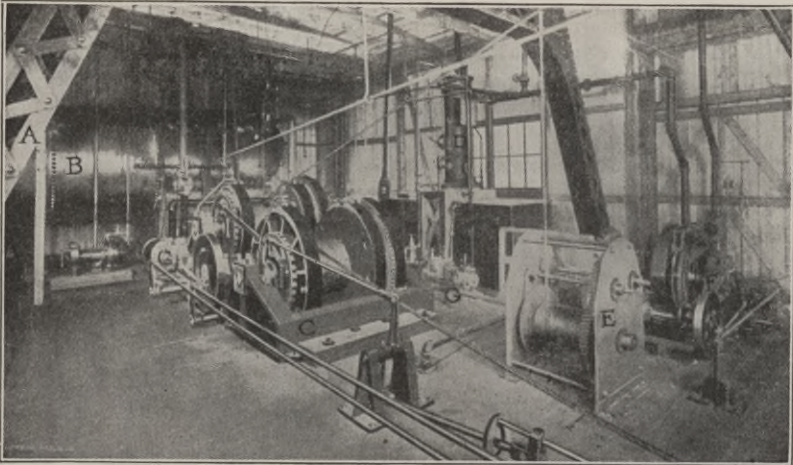

Fig. 28. Interior View of Scraper Bucket Excavator. A, A-Frame; B, Boiler; C, Hoisting Engine; D, Feed-Water Heater; E, Deck Winch; F, Swinging Engine; G, Feed-Water Pump

*Courtesy of Lidgerwood Manufacturing Company, New York City*

standard duplex type is generally connected to a water supply from which the boiler is furnished by an injector. A feed-water heater is often necessary to purify alkali waters before they are admitted to the boiler.

The main or hoisting engines are of the horizontal, double-cylinder, friction-drum type. The swinging engine may be a part of the main engine or a separate mechanism. The latter method is the more satisfactory. The hoisting engine in this case has two drums, one for the hoisting cable and the other for the drag line. These drums are often controlled by double-band outside friction

clutches operated by auxiliary steam rams. The swinging engine is of the steam, reverse type and drives, through a chain of gears, a pinion which operates the large circular rack on the lower frame. The power equipment of a typical drag-line excavator is shown in Fig. 28.

*Electric Power.* Where electric power is available and reasonable in cost, it is advisable to use electric motors, in place of the steam-boiler equipment. Either alternating or direct current may be used. The motors may be gear or belt-connected to the shafts of the hoisting and swinging engines. The drums of these engines are controlled by outside-band friction clutches, which are actuated by pneumatic-thrust cylinders. A small belt-connected air compressor with receiving tank supplies the compressed air for the rams. On a 120-ton machine equipped with a  $2\frac{1}{2}$ -yard dipper, a 115-horsepower, 60-cycle, 3-phase motor for the hoisting engine, and a 50-horsepower, 60-cycle, 3-phase motor for the swinging engine are suitable for the power equipment. The cost of current will vary from  $\frac{1}{4}$  to 1 cent per cubic yard, depending on the market price.

The reliability, cleanliness, and economy of this form of power are strong factors in favor of its use. It has proved very advantageous in reclamation work in the arid regions of the West, where coal and water are scarce and expensive, and electric power is available from near-by transmission lines of water-power plants.

*Gasoline Power.* Gasoline and kerosene engines have been successfully used in the operation of the machinery of the smaller sizes of scraper-bucket excavators. The engine is mounted on a base just to the rear of the drum mechanism to which it is belt-connected. A 50- to 80-horsepower engine is necessary for the efficient operation of hoist and swinging engines. The drums of the hoisting mechanism are provided with outside-band friction clutches, which are controlled by pneumatic-thrust cylinders. Double-cone friction clutches are used to operate the drums of the swinging mechanism. A small air compressor actuated by a belt connection with the engine furnishes compressed air to a receiving tank. The air is supplied to the thrust cylinders, which operate the band friction clutches on the drums. A water tank for supplying water to cool the engine cylinder and a gasoline supply tank are also placed on the upper platform near the engine.

The gasoline engine is the most economical type of prime mover or power producer in localities where coal and water are scarce and expensive, and electric power is not available.

**Excavating Equipment.** The excavating equipment consists of the **A-frame**, boom, and bucket.

The **A-frame** is generally a framework, shaped like the letter **A**, composed of wooden or steel members. This frame is located near the front end of the platform. The top of the boom is connected by cable with the top of the frame which is also guyed back to the two rear corners of the platform. The top of the boom may be raised and lowered by means of a wire cable, which passes from the

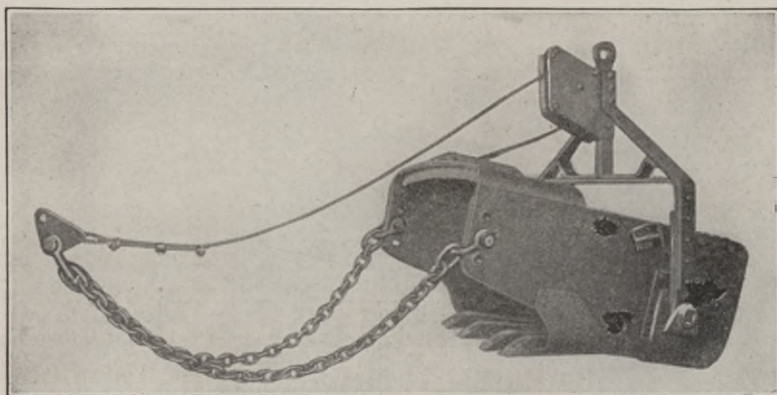

Fig. 29. Page Scraper Bucket

end of the boom over a sheave at the top of the **A-frame** and thence down to the deck winch.

The boom is generally a steel framework which is pivoted to the front end of the platform. The upper end of the boom is framed so as to form a boxing for one or more sheaves over which the hoisting cable passes.

The bucket may be one of three types: the scraper bucket, the clam-shell bucket, and the orange-peel bucket. The last two types will be discussed in the section under "Floating Dipper Dredges", Part II. The scraper bucket is the type generally used with a drag-line excavator. It consists of a box-shaped scoop made of heavily reinforced, shaped steel plates. The lower front edge is the cutting edge and is made of manganese steel and for hard material

is provided with teeth. There are several makes of these buckets, which differ only in their details of construction. The Page bucket is shown in Fig. 29.

**Method of Operation.** A steam-operated machine requires the services of four men: an engineer, a fireman, and two laborers. The engineer stands at the front end of the platform and by means of the levers and brakes controls the entire operation. The fireman keeps the boiler fed with fuel and water and has general supervision of the machinery. The laborers act as pitmen and are of general service about the machine. The fireman can be eliminated in the case of the excavators operated by electric motors or internal-combustion engines.

The operation of excavation commences with the bucket in the first position shown in Fig. 27. The engineer releases the hoisting-line and drag-line drums and allows the bucket to drop to the surface, where it will be in the second position shown in Fig. 27. In descending, the weight of the bucket maintains its vertical position and forces the cutting edge into the soil, giving it an initial bite. With the hoisting line still released, the operator starts up the drag-line drum and pulls the bucket toward the machine. The first pull on the drag line tilts the bucket to the proper position for the penetration of the soil. By a slight manipulation of the hoisting line, the proper angle of the bucket may be kept for a deep cut in soft soils or for a thin cut in hard soils. When the bucket is filled, the drag-line drum is set and the hoisting drum is started, and this automatically raises the front end of the bucket and thereby prevents the spilling of the contents during the swing to the spoil bank. The front end of the bucket is held up by means of the tension of the dumping line which is the upper branch of the drag line. See third position of the bucket in Fig. 27. When the dumping position is reached, the operator releases the drag line and the bucket revolves into a vertical position and dumps. The tension is applied or released by pressure on the brake lever actuating the drag line and hence the operation of dumping is always under the control of the operator.

**Cost of Operation.** The cost of operation of a scraper-bucket excavator depends on the class of work, the kind of material to be handled, the size of the machine, the efficiency of the operator, the character and cost of the power used, etc.



*Illustrative Example.* The type of machine in general use is a steam-power excavator, equipped with a  $2\frac{1}{2}$ -yard bucket. Such a machine, on ditch or railroad construction should excavate about 1200 cubic yards of loam and clay during a 10-hour working day. The following is a typical case of the cost of operation, under such conditions, for a 10-hour day:

#### Operating Cost of Steam-Power Scraper-Bucket Excavator

##### Labor:

1 engineer	\$5.00
1 fireman	3.00
2 laborers, @ \$1.75 each	3.50
1 team and driver (hauling coal, etc.)	3.50
Total labor cost, per day	\$15.00

##### Fuel and Supplies:

2 tons of coal, @ \$4.00	\$8.00
Oil, and waste	1.75
Water	0.35
Total fuel and supplies	\$10.10

##### General and Overhead Expenses:

Repairs	\$4.00
Incidental expenses	2.00
Depreciation (10% of \$10,000)*	5.00
Interest (6% of \$10,000)*	3.00
Total general and overhead expense	\$14.00

Total Cost of Operation for 10-hr. Day \$39.10  
 Average Daily Excavation (cu. yd.) 1200  
 Unit Cost of Scraper-Bucket Excavating, cu. yd.,  $\$39.10 \div 1200 = 00.033$

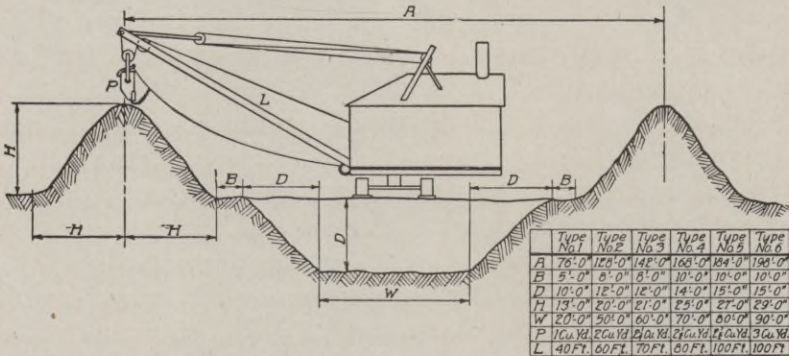

Fig. 30. Diagram of Limitations of Drag-Line Excavators

\* Based on a life of 10 years and 200 working days per year.

**Field of Usefulness.** The field of work of the drag-line excavator has become a wide one since 1910. Its early use was largely in reclamation work, the construction of ditches and dikes on irrigation and drainage projects. Its great length of boom gives this excavator a wide radius of operation and permits of the deposition of material in spoil banks at a sufficient distance from the sides of the cut to prevent caving of the banks. The drag-line principle permits the excavation of material at a considerable depth below the surface and its elevation to a correspondingly high elevation

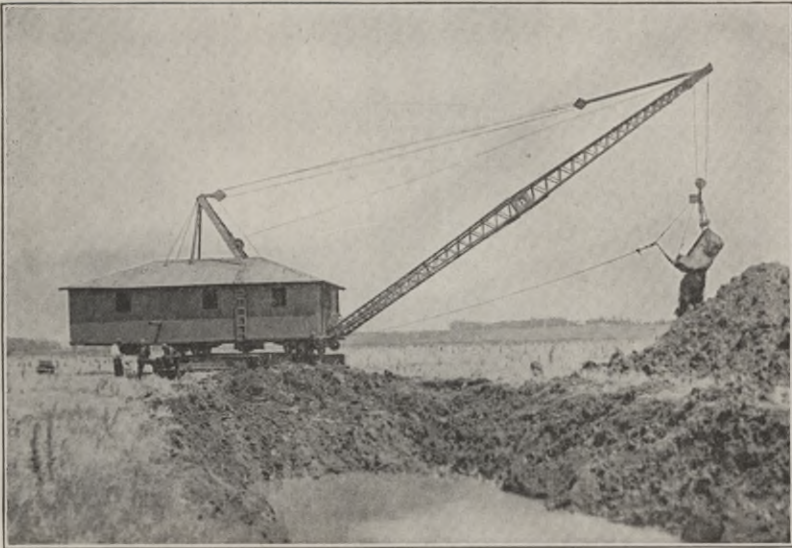

Fig. 31. Revolving Excavator on Caterpillar Tractor Operating on Drainage Work

above the surface. The limitations of the drag-line excavator are shown in Fig. 30.

The use of the caterpillar tractor allows a heavy machine to move over soft, wet soils on drainage work. The machine starts at the lower end of the canal and excavates as it moves upstream, thus allowing the surplus soil water to drain off through the new channel. The careful operation of the bucket will result in the construction of a canal with smooth and uniform bottom and side slopes. An example of this class of earthwork is shown in Fig. 31. Recent experience in the South and West has proved the efficiency of this type of excavator in the construction of dikes and earthen dams on

reclamation projects and embankments on railroad work. The machine moves parallel to the work and borrows the material from one side, or moves ahead of the work and borrows the material from both sides.

Earthen dams and dikes, if of large size, should be made in layers of about 6- to 8-inch depth, and each layer wetted and rolled by a heavy steam roller before the deposition of the material for the next layer. Small dikes and railroad fills can be satisfactorily built without wetting and rolling. The drag-line excavator saves



Fig. 32. Drag-Line Excavator Operating on Placer Mine in Siberia

the haulage equipment necessary in this class of earthwork where either an elevating grader or a power shovel is used.

The scraper-bucket excavator is very efficient in the excavation of gravel pits and in stripping soil from quarries and mines. When the power shovel has become drowned out of a pit which has been flooded, the drag-line machine can work from a higher level and excavate for a considerable distance below the water. Fig. 32 shows a drag-line excavator, equipped with a  $1\frac{1}{2}$ -yard bucket and a 65-foot boom, which operated successfully in 1915 on a large placer mine in eastern Siberia. Such a machine has proved to be very

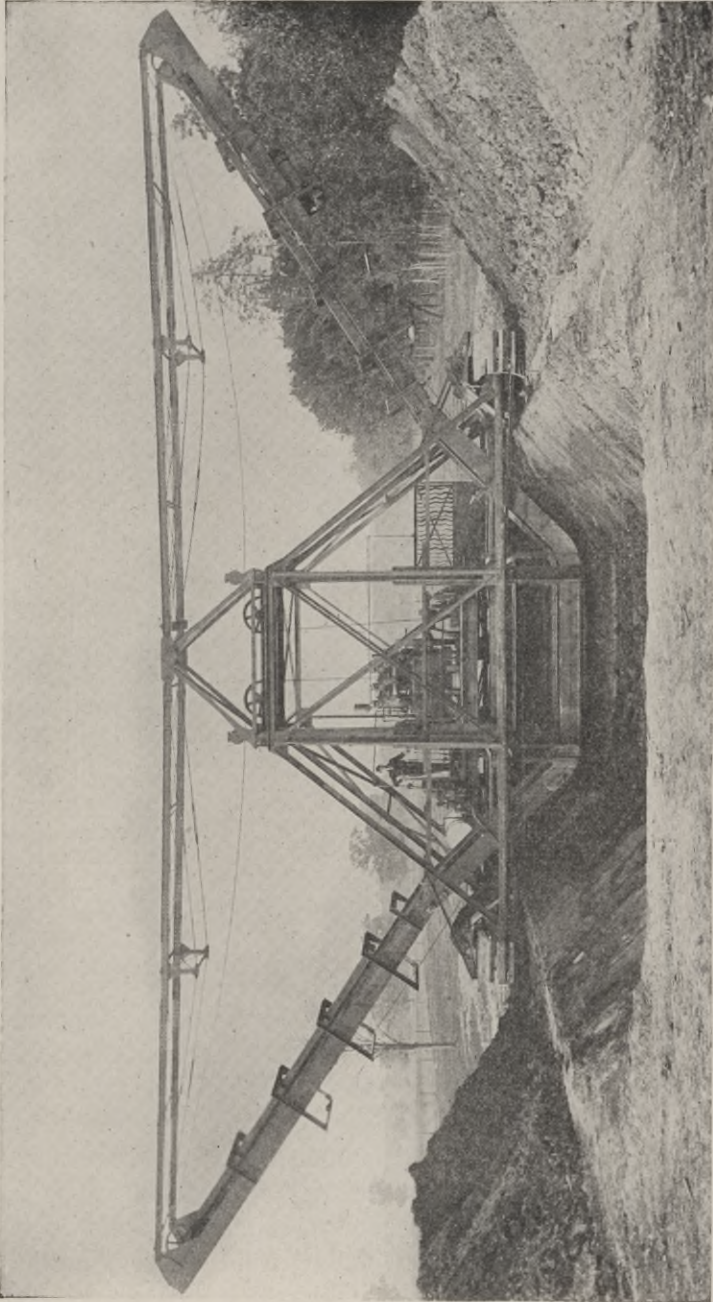

Fig. 33. Wide-Bottom, Templet Excavator  
Courtesy of F. C. Austin Drainage Excavator Company, Chicago

economical where conditions do not warrant or permit the use of a large hydraulic dredge.

#### TEMPLET EXCAVATOR

Considerable difficulty has been experienced in the maintenance of drainage and irrigation channels. This has been caused by their rapid filling up with silt, débris, and vegetable growth. Many forms of dredges construct the channels with rough bottoms, uneven sides, and steep banks, which are subject to subsequent caving. These irregularities in the surfaces of the channels retard the flow of the water and augment the deposition of silt, débris, and other heavy materials carried by the water in suspension. During the decade

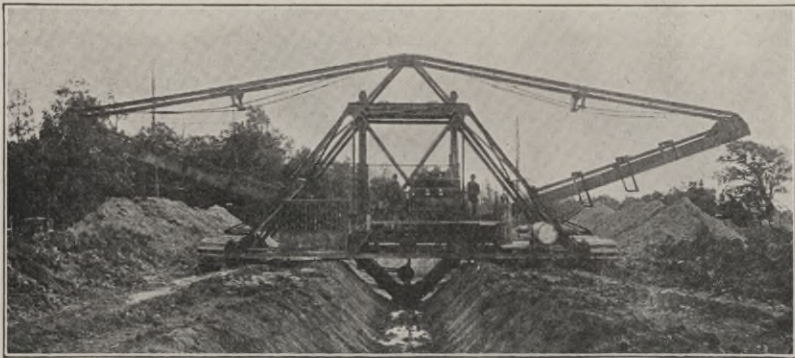

Fig. 34. Narrow-Bottom Templet Excavator  
*Courtesy of F. C. Austin Drainage Excavator Company, Chicago*

1905–1915, a unique type of excavator, called the templet excavator, came into use for the construction of open ditches with true and smooth side slopes and grades.

**Construction.** A double-faced, reversible, positive-cleaning bucket moves along a guide frame, which is shaped at its lower section to the desired cross-section of the ditch. The guide frame is supported on a platform or framework composed of structural-steel members, strongly braced and bolted together. This platform is supported on wheel trucks or caterpillar tractors, which are necessary for soft, wet soils. Templet excavators with wide and with narrow frames are shown in Figs. 33 and 34, respectively.

**Power Equipment.** Power for the operation of the machine may be furnished by a steam-power equipment or by an internal-

combustion engine. The latter type of power equipment has generally been found to give very satisfactory results and to be cleaner, cheaper, and simpler in operation than the ordinary steam plant. If a steam engine and boiler are used, a 25-horsepower to 40-horsepower engine will be required, while a gas engine for the same machine should have from 50 horsepower to 80 horsepower. The power plant is mounted on the central part of the platform and is operated with a set of levers by one man.

**Excavating Equipment.** The excavating equipment consists of the guide frame and the bucket. The guide frame is made up of 2

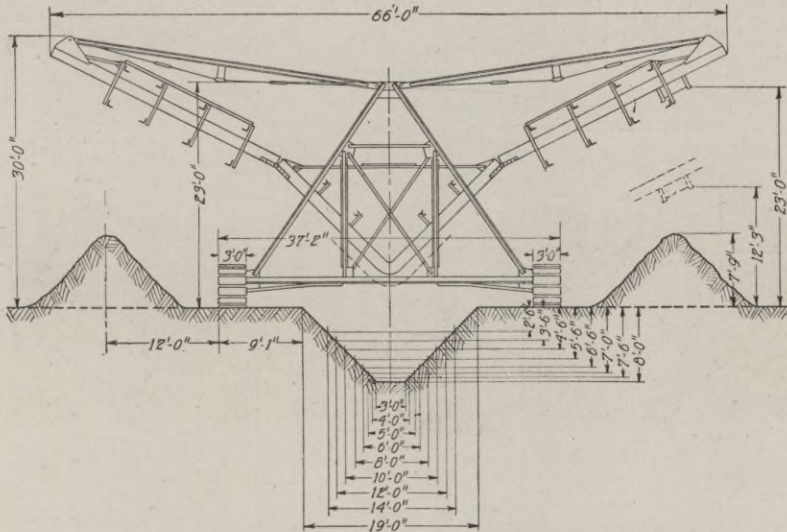

Fig. 35. Limitations of Templet Excavator with Narrow-Bottom Frame  
Courtesy of F. C. Austin Drainage Excavator Company, Chicago

steel members which are placed parallel and form a track over which the bucket moves. This frame is made in two shapes at its bottom section to provide for the excavation of narrow and of wide ditches; the side slopes are nearly 1:1. The frame is well braced by steel-frame members and can be raised and lowered through the platform.

The bucket is a rectangular-shaped box with 2 open ends and cutting edges. A plunger head fits inside the box section.

**Method of Operation.** The guide frame is lowered to the ground surface and the bucket drawn down and along the bottom of the frame. As it moves along it cuts a thin slice of earth which is

carried on to the upper section of the frame. Here trips are located and they push the plunger head through the bucket and thus the contents are discharged into either wagons or cars or upon a spoil bank below. As the bucket moves back and forth along the frame, the latter is lowered so as to gradually feed the bucket into the earth and increase the depth of cut. Thus a section of ditch prism about  $3\frac{1}{2}$  feet in length is made with one position of the machine. The machine then moves ahead and cuts another section of ditch,

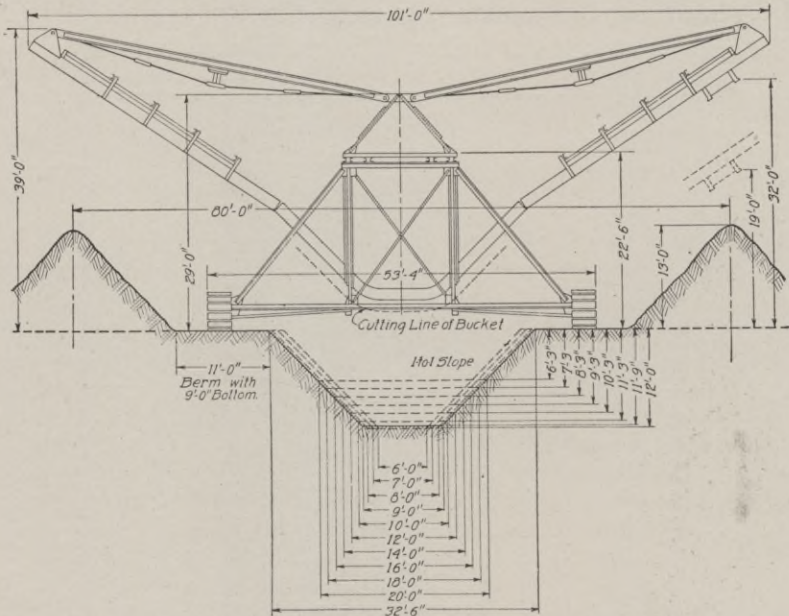

Fig. 36. Limitations of Tement Excavator with Wide-Bottom Frame  
Courtesy of F. C. Austin Drainage Excavator Company, Chicago

and so on. The limitations of the two types of templets—narrow and broad bottoms—are given in Figs. 35 and 36.

**Cost of Operation.** The gasoline-power machine equipped with caterpillar tractors is the type of templet excavator, which is most generally used in the excavation of channels in loose and soft soils. For the operation of this machine a crew of 3 to 4 men would be required; an engineer, an assistant, a laborer, and a teamster. A steam-operated machine, run on a track would require the services of one or two extra men to haul fuel, move track, etc. The engineer operates the bank of levers which control the movement of the

bucket, the raising and lowering of the frame, and the tractive movement of the machine along the surface. The assistant keeps the machinery oiled and in good working order. The laborer provides planking or tracking where necessary, and does general service about the machine. The teamster hauls the gasoline, water, and supplies necessary for the work.

*Illustrative Example.* The cost of operation of a typical machine in the construction of a drainage channel through alluvial soil under favorable conditions would average about as follows for a 10-hour day:

#### Operating Cost of Templet Excavator

*Labor:*

1 engineer	\$4.00	
1 assistant	2.50	
1 laborer	2.00	
1 team and driver	3.50	
Total labor cost, per day		\$12.00

*Fuel and Supplies:*

35 gallons of gasoline, @ 20c	\$7.00	
Oil, waste, etc.	1.00	
Total fuel and supplies		\$8.00

*General and Overhead Expenses:*

Depreciation (12½% of \$12,000)*	\$10.00	
Interest (6% of \$12,000)*	4.80	
Repairs and incidentals	4.20	
Total general and overhead expense		\$19.00

Total Cost of Operation for 10-hour Day		\$39.00
Total Excavation (cu. yd.)	700	
Unit Cost of Templet Excavating, per cu. yd., $\$39.00 \div 700 =$		00.055

**Field of Usefulness.** A water channel, to secure highest efficiency of operation, should have a true grade and uniform and smooth side slopes. On irrigation and drainage projects, the distribution canals and open ditches are peculiarly susceptible to filling up with silt, débris, and vegetable matter during seasons of low flow. In the case of small ditches, this filling up may become so great in a few years as to render the channel practically useless. This means that these artificial waterways must be cleaned out every few years in order to maintain their efficiency and capacity. In order to

\* Based on 150 working days a year and an 8-year life.



reduce this maintenance expense to a minimum, it is advisable to construct the channels as nearly mechanically perfect as possible.

The templet excavator is the best form of excavator for the construction of an open channel, where the soil conditions are favorable. In alluvial soils, such as loam, clay, sandy loam, and marl, the machine does very satisfactory work. But in hard soils, such as hard pan or indurated gravel, and in lands where many obstructions such as stumps, boulders, and roots occur, the progress is slow and difficult and the work expensive.

#### WHEEL EXCAVATOR

The wheel excavator is a machine which has been devised to excavate small open ditches on reclamation work. Most types of



Fig. 37. Wheel Excavator Constructing Small Drainage Ditch

excavators are unfitted on account of size and method of operation to construct the smaller lateral ditches of drainage and irrigation systems, and there has been a great demand, beginning in the decade of 1905-1915, for a small, light, portable machine, which can excavate to a true and uniform cross-section.

**Construction.** The ditcher consists of a frame which supports the power equipment on the front end, and a pivoted framework containing the excavating wheel on the rear end. The platform is supported at the front on an axle which has 2 broad-tired steel wheels, and at the rear by 2 caterpillar tractors, which allow the machine to operate in wet, soft soils. A view of a wheel excavator constructing a small drainage channel is shown in Fig. 37:





**VIEW OF CULEBRA CUT FROM CONTRACTOR'S HILL, SHOWING DREDGES AT WORK ON THE CUCARACHA SLIDE**  
This gives a very clear idea of the nature of the Contractor's problem at this very troublesome point. In the foreground is a ladder dredge and further over a shovel dredge working on the tons of earth which have settled down into the Canal passageway.

*Courtesy of Panama Canal Commission, United States Government, Washington, D. C.*

**Power Equipment.** The power may be supplied either by a steam or internal-combustion engine. The earlier machines were supplied with the former type of engine but the more recent machines are nearly all equipped with gasoline engines. These gasoline engines are generally of the marine type and made with 4-cycle multiple cylinders, ranging from 20 horsepower to 90 horsepower. They are provided with high-tension magneto and dual ignition.

The motive power is transmitted to the wheels either by sprocket chain or bevel-gear drive.

**Excavating Equipment.** The excavating equipment consists of the excavating wheel and belt conveyor. The wheel is an open steel frame, around the periphery of which are attached from 8 to 12

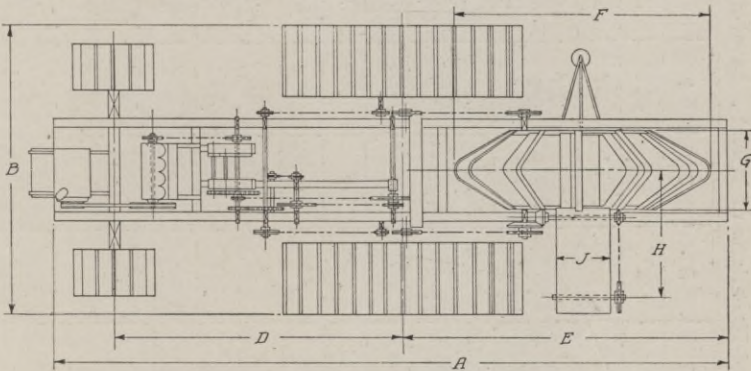

Fig. 38. Diagram of General Dimensions and Specifications of Wheel Excavators

buckets of scoop shape. At the rear and near the upper part of the wheel is placed the belt conveyor, which projects out a considerable distance either side of the machine.

**Method of Operation.** The excavating wheel revolves either on a central axle or anti-friction wheels placed along its rim and each bucket cuts out a thin slice of earth which is deposited on the machine end of the belt conveyor, when the bucket reaches the top of the wheel. The operator gradually feeds the wheel into the ground as the wheel revolves. After one section has been dug to the required depth, the machine moves ahead several feet under its own power and another section is dug, and so on. The sizes, limitations, and capacities of the various sizes of a well-known make of wheel excavator are given in Fig. 38 and Table V.

TABLE V  
General Dimensions of Wheel Excavators

Size Number	1	2	3	4	5	6	7	8	9
Length Over All	A 35'	41'	42'	44'6"	48'	49'6"	53'	55'	55'
Width Over All	B 14'	16'	19'3"	20'	21'	22'6"	24'8"	26'8"	28'8"
Height Over All	C 16'	18'	18'	18'	18'6"	19'	19'	19'6"	19'6"
Wheels Center to Center	D 14'6"	16'	16'	18'6"	20'	21'3"	24'	26'	26'3"
Traction Aprons	$3\frac{1}{2}' \times 10'$	$4' \times 10'$	$5' \times 10'$	$4\frac{3}{4}' \times 12'$	$5\frac{1}{2}' \times 12'$	$6' \times 12'$	$6' \times 14'$	$6\frac{1}{2}' \times 14'$	$7' \times 14'$
Rear Axle to Rear End	E 19'	20'6"	21'	23'	23'6"	24'	24'	24'	24'
Cutting Wheel Diameter	F 14'	15'	17'	18'4"	19'	19'	19'	19'	19'
Cutting Wheel Width	G 2'6"	4'6"	6'	7'	8'	9'	10'	11'	12'
Wheel Cut, Greatest Depth	5'	6'	6'	6'	6'6"	6'6"	6'6"	6'6"	6'6"
Ditch Center to Conveyor End	H 4'6"	7'	9'6"	11'	12'6"	14'	15'6"	16'6"	18'
Conveyor Belt Width	J 24"	30"	30"	30"	36"	36"	36"	36"	36"
Machine Weight, Net	(lb.) 36,000	42,000	50,000	58,000	66,000	75,000	83,000	91,000	100,000
Export Weight (Gross)	(lb.) 42,400	49,500	58,800	68,300	77,700	88,300	97,800	107,200	117,800
Export Weight (Tare)	(lb.) 6,400	7,500	8,800	10,300	11,700	13,300	14,800	16,200	17,800
Export Volume, Knocked Down and Crated	(cu. ft.) 900	1,050	1,250	1,450	1,650	1,875	2,075	2,275	2,500
Cost, F. O. B. Factory	\$4,200	\$6,000	\$7,000	\$8,500	\$9,500	\$11,000	\$11,500	\$12,000	\$13,500

Compliments of Buckeye Traction Ditcher Company, Findlay, Ohio

**Cost of Operation.** The cost of operation depends on the size of the job, the size and make of excavator, the character and condition of the soil, the efficiency of the operator, etc.

*Illustrative Example.* With a machine which digs a ditch with a top width of 4 feet 6 inches, an average depth of 3 feet 6 inches, bottom width rounded to 12 inches, and side slopes of about  $\frac{1}{2}$ :1, the average cost of operation for a 10-hour day would be about as follows:

#### Operating Cost of Wheel Excavator

*Labor:*

1 operator, @ \$125 per month	\$4.00	
1 assistant	2.50	
1 laborer, @ \$2.00	2.00	
1 team and driver	3.50	
Total labor cost, per day		\$12.00

*Fuel and Supplies:*

30 gallons gasoline, @ 20c	\$6.00	
Oil, waste, and supplies	1.00	
Total fuel and supplies		\$7.00

*General and Overhead Charges:*

Depreciation ( $12\frac{1}{2}\%$ of \$6000)*	\$5.00	
Interest (6% of \$6000)*	2.40	
Repairs and incidentals	4.60	
Total general and overhead expense		\$12.00

Total Operating Cost per 10-hour Day		\$31.00
Average Progress per Day (ft.)	2000	
Average Daily Excavation (cu. yd.)	700	
Unit Cost of Wheel Excavating, per cu. yd., $\$31.00 \div 700 =$		00.044

**Field of Usefulness.** The wheel excavator is the most practical form of excavator for small ditches where the soil conditions are favorable. This machine cannot excavate economically very hard, dense soils, or where large quantities of stumps, boulders, and other obstructions are present. In glacial clay, alluvium, marl, and similar soils, this excavator operates very smoothly and satisfactorily.

In irrigation and drainage systems, where the smaller ditches run full only a small part of each year, a large amount of silt, debris, and vegetation gradually accumulates. These obstructions in the course of a few years will gradually fill up and greatly reduce the

\* Based on 150 working days a year and an 8-year life.

carrying capacity of the channels. Hence it is necessary to construct the smaller channels to as near true grade and cross-section as is practicable. In open, porous soils, such as occur often on irrigation projects, it becomes necessary to line the ditches with some

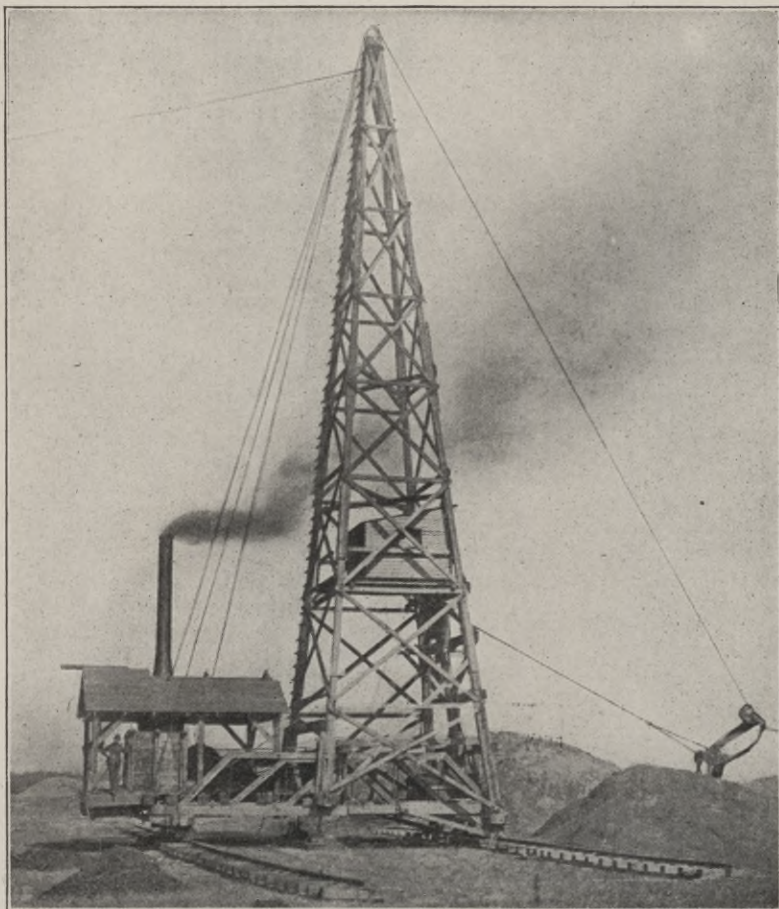

Fig. 39. Tower Excavator Operating on New York State Barge Canal

impervious material such as concrete to prevent large seepage losses. In such cases it is a great advantage to excavate a channel, which is to be subsequently lined, with a true grade and smooth side slopes, so that the form work for the concrete may be set without the extra labor and expense of trimming and shaping the excavation.

## TOWER EXCAVATOR

The tower excavator is a unique type of machine which was developed and used with success several years ago on the Chicago Drainage Canal and recently on the construction of the New York State Barge Canal. As will be seen from Fig. 39, this excavator derives its name from its principal part, which is a movable tower.

**Construction.** The tower is a framed, timber structure, the height of which is determined by the width of the area to be excavated. The tower rests on a platform or car, which is braced by overhead, horizontal-chord, combination trusses. This car is mounted on 4 solid, double-flanged cast-steel wheels generally about 14 inches to 16 inches in diameter and with 4-inch treads. The wheels run on a track, which consists of 80-pound to 90-pound rails, spiked to cross ties, which are bolted to 30-foot planks. The car and tower are moved ahead by a cable which passes over a sheave on the car and thence to a "deadman" or anchorage placed at a suitable point ahead of the car, and then back to a drum on the engine. The tower is braced to the car by cables which extend from the top of the tower to the rear corners of the car.

**Power Equipment.** The power equipment is placed on the rear of the car and consists of a vertical boiler and a double-drum hoisting engine. The engine is usually of the vertical, reversible type, with double, 40-inch by 12-inch cylinders, and equipped with friction-clutch control for the drums.

**Excavating Equipment.** The excavating equipment consists essentially of a 2-line scraper bucket. At the rear of the bucket is a frame carrying 2 sheaves at right angles to the cutting edge, which is strongly reinforced and provided with teeth for the excavation of hard material. On the bottom of the bucket are attached 2 curved shims, or shoes. The front of the bucket is connected to the drag-line drum of the engine by a cable which passes over a sheave suspended on the front side of the tower about  $\frac{1}{4}$  of its height from the base. Another cable extends from the hoisting drum of the engine over a sheave at the top of the tower, then between the sheaves on the bail of the bucket and then to an anchorage at the far side of the excavation.

**Method of Operation.** The bucket is lowered over the hoist line by allowing it to slide down the cable by its own weight, to the



far side of the cut. Then the bucket is loaded by pulling it toward the tower by winding up the drag-line cable. When the spoil bank is reached, the hoisting cable is raised and the bucket is overturned and dumped. The bucket is returned to the excavation by still further tightening the hoisting cable and releasing the drag-line cable, whereby the bucket rises and slides back to the starting point. Where a tower 65 feet in height has been used, a reach of 210 feet from the far side of the excavation to the near side of the spoil bank was attained with efficiency of operation. A bucket, of

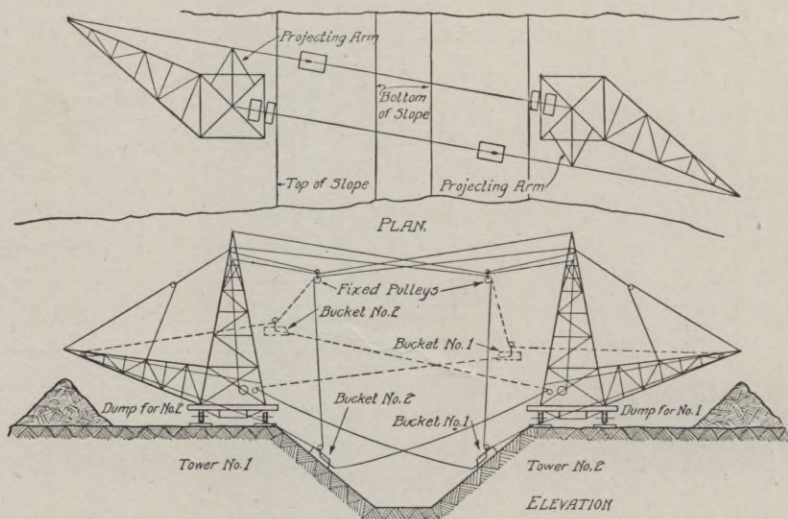

Fig. 40. Diagram of Double-Tower Excavator

2-cubic yard capacity, made an average output of 3 cubic yards and was operated at the rate of 4 cubic yards per minute.

A crew of from 5 to 9 men is required to operate a tower excavator, depending on the magnitude of the job, the character of the material to be excavated, etc. Under average conditions, there will be required an operator, a fireman, a team and driver, and 3 laborers. The operator is stationed on a platform on the rear side of the tower and at about  $\frac{1}{3}$  its height. He controls the machinery by a set of levers and brakes and has an unobstructed view of the work. The fireman keeps the boiler and machinery supplied with fuel, water, and oil, and in proper working condition. The team and

driver haul fuel, water, and supplies to the work. The laborers move the track and perform general service about the work.

**Double-Tower Excavator.** A double-tower excavator was used some years ago on a section of the Chicago Drainage Canal. A diagrammatic view of this excavator is shown in Fig. 40. As will be noted from the plan, the inclined booms were so designed that a straight line from the apex of either tower to the point of the opposite boom, clears the side of the tower. This allowed each bucket to clear the tower and empty directly on the adjacent spoil bank.

A double-drum hoisting engine was located on the side of the platform of each tower. Each bucket was operated by a drag line and a hoisting line. The buckets were loaded, dumped, and returned to the excavation as is described above for the single tower excavator. By changing the location of the suspended sheaves, the position of the bucket in digging was altered so as to reach the entire half width of the canal prism. This machine, in the excavation of a canal section having a bottom width of 26 feet, side slopes of 2:1, and an average depth of 27 feet, through a clay soil, did very satisfactory work.

**Cost of Operation.** *Illustrative Example.* The following may be taken as an estimate of the cost of operation of a single-tower excavator, equipped with a 75-foot tower, controlling a 250-foot width of excavation, a 2-yard scraper bucket, and a 10×12-inch double-drum, vertical hoisting engine. The excavated material would be dumped upon a spoil bank at the tower side of the excavation and into wagons or dump cars by means of a loading platform. A train of four 5-yard dump cars would be loaded in about 15 minutes. An average output of 600 cubic yards would be attained in the excavation of a glacial clay under average working conditions during a 10-hour working day:

#### Operating Cost of Single-Tower Excavator

Labor:

1 engineer	\$4.00	
1 fireman	2.50	
1 team and driver	3.50	
3 laborers, @ \$2.00 each	6.00	
Total labor cost, per day		\$16.00

*Fuel and Supplies:*

$\frac{3}{4}$ ton of coal, @ \$4.00	\$3.50	
Oil, and waste	0.50	
Total fuel and supplies		\$4.00

*General and Overhead Expenses:*

Depreciation, (10% on \$2000)*	\$1.40	
Interest (6% of \$2000)*	0.80	
Repairs, and incidentals	5.50	
Total general expense		\$7.70

Total Cost of Operation for 10-hr. Day		\$27.70
Average Excavation per 10-hr. Day (cu. yd.)	600	
Unit Cost of Single-Tower Excavating, per cu. yd., \$27.70 ÷ 600 =		00.046

**Field of Usefulness.** The tower excavator was originally used in canal excavation where the cross-section was very wide with a comparatively shallow depth. When the top width of a channel is over 80 feet, it becomes necessary to use drag-line excavators in pairs, one along each bank, or a floating dipper dredge which shifts from one side of the channel to the other. The tower excavator can cut the full width of the channel at one set-up and complete the section as it moves along. This type of excavator could not be used satisfactorily in very wet soils, or where rock occurred in great quantity.

The tower excavator is especially efficient in the excavation of large, shallow areas such as reservoirs, athletic fields, and the basements of large buildings. In such cases, it might be advisable to have the tower or towers move over curved tracks; the center of curvature being the point of anchorage of the hoist cable.

Quarries, surface mines, and gravel pits can be economically stripped with a tower excavator, when the area covered is sufficient to warrant the installation of the plant and the soil conditions are favorable to uniform scraper-bucket operation.

**WALKING SCOOP DREDGES**

The walking dredge is rather a novelty in the field of excavating machinery and derives its name from its ability to move over the ground under its own power and to turn short angles or curves without sliding or skidding. The walking scoop type was devised about 1905, and is similar in general construction and operation to the

\*Based on a 10-year life and 150 working days per year.

floating dipper dredge. Another type, placed on the market in 1914, is an adaptation of the "walking" principle to the drag-line excavator and will be discussed later.

**Construction.** The walking scoop dredge consists essentially of a wooden hull supported on 6 legs or feet and supporting the operating machinery and excavating equipment. The hull is constructed of heavy timbers and is braced longitudinally by large, overhead, wooden trusses. It is usually made of sufficient width to straddle the ditch which it is excavating. On the front of the hull is placed the A-frame, which consists of two heavy timbers, bolted to the sides of the hull at their lower ends and joined at the upper ends to a "head" casting. The A-frame sets in nearly a vertical

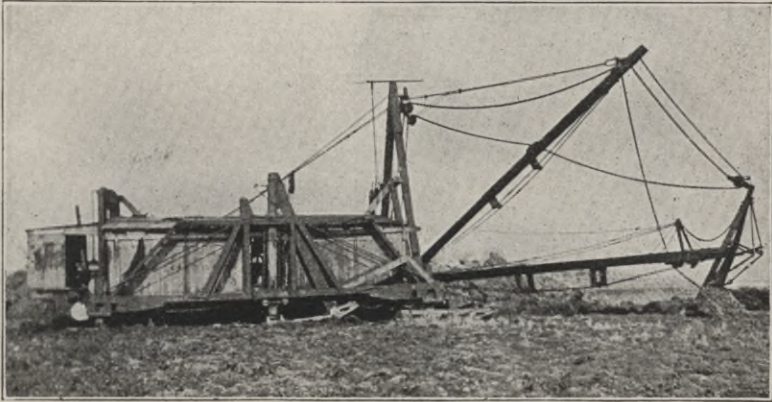

Fig. 41. General View of Walking Scoop Dredge

plane and is braced to the rear corners of the hull by wire cables which extend to the top of the frame.

**Operating Equipment.** The operating equipment for steam power is similar to that used for a floating dipper dredge. The boiler is placed at the rear of the hull, and in front of it are the hoisting and swinging engines. These will be fully discussed in the section entitled "Floating Dipper Dredges".

On several jobs, it has been found to be more economical to use a gasoline engine instead of the steam equipment. Engines of the multiple-cylinder marine type are generally used and vary from 16 horsepower to 50 horsepower, depending on the capacity of the excavator, the size of the ditch, and the character of the soil. A machine

with a 40-foot boom and a  $\frac{3}{4}$ -yard dipper has been satisfactorily operated by a 50-horsepower engine.

**Walking Equipment.** The hull is supported at each of its corners by a timber platform shaped like a large stone boat. Each "foot" is about 6 feet wide, 8 feet long, and 4 inches thick, and has an iron rod bolted across the bottom near the front edge to prevent slipping. Each pair of feet is connected by a timber so that the two feet will move conjointly. Each foot is pivoted to the hull and connected to a drum of the swinging engine by a chain, so that the feet may be turned by the revolution of the drum. In the center



Fig. 42. Dipper and Dipper Handle of Walking Scoop Dredge

of each side or midway between the corner feet is a center foot similar in construction to the corner feet. On the under side of each center foot, a transverse 6-inch by 6-inch timber is bolted to prevent sliding or slewing. A large timber extends from the top of each center foot, between each pair of trusses, where it is pivoted. A chain, one end of which is fastened to the side timbers of the hull, passes over two pulleys attached to the frame on which the foot support is pivoted, and then passes along the hull to the rear corner and across the back end to a drum near the center of the hull.

The movement of the excavator is effected as follows: The drum is revolved and the chain pulls the foot support gradually to a vertical position. This raises the dredge from its corner feet and shoves it ahead about 6 feet. The rear chain is then released and the weight taken off the center feet, which are pulled ahead by a chain attached to a drum, located near the front part of the hull. A general view of a walking scoop dredge is shown in Fig. 41.

**Excavating Equipment.** The excavating equipment consists of the boom, dipper handle, and dipper, all of which are of unusual design in this machine.

The boom is made up of two parts; the upper part is supported

at its lower end on a turntable, similar to those used on a floating dipper dredge. The upper end is supported by a cable from the peak of the A-frame. The lower part of the boom is pivoted at one end to the lower end of the upper section and on its outer end is pivoted an iron-trussed framework shaped like a walking beam. This framework is the dipper handle, to the lower end of which is attached the dipper which is shaped like a slip scraper. The dipper and dipper handle are shown in Fig. 42.

A chain or cable passes from the upper end of the handle to a drum on the hull. By winding up this chain or cable, the top of the frame is pulled back. A chain or cable is also fastened to the lower end of the handle at the back of the scoop. This line passes over sheaves in the outer ends of the booms and thence to a drum on the hull. The method of excavation is as follows: The lower section of the boom is lowered until the tip of the scoop is at the required elevation; the line attached to the upper end of the dipper handle is drawn in by revolving the drum, and the scoop is thus forced into the earth. After the scoop is filled, the lower section of the boom is raised and simultaneously the whole boom is swung to one side until the scoop is over the spoil bank, when the upper line is released and the lower line is drawn in until the scoop is pulled back to the boom and the contents of the scoop are dumped.

The walking scoop dredge can move across fairly level land at the rate of about 1 mile in a 10-hour day. It can make a quarter turn in about 50 feet. It may be operated as a rear or head-on excavator. In the first case, the machine starts at the outlet and works upstream, backing away from the excavation similar to the drag-line excavator, while in the latter case, the machine starts at the upper end of the channel and straddles it as it works downstream.

#### WALKING DRAG-LINE EXCAVATOR

This machine is an adaptation of a walking traction device to the drag-line excavator. The advantages of this method of traction over the ordinary ones of rollers, wheels, or caterpillars, are the production of a direct bearing pressure on the soil and the elimination of track, plankways, skids, and the labor necessary for their manipulation.

**Construction.** The walking drag-line excavator differs from the ordinary drag-line machine principally in its substructure construction. The customary lower frame and truck rollers or caterpillar tractors are replaced by the walking device, which is quite different in design and operation from that described above for the walking scoop dredge.

The superstructure of this excavator is very similar in design and construction to the ordinary drag-line excavator. Three sizes of machine are in regular use: the smallest, equipped with a 40-foot boom, a 1-yard bucket, and operated by a 45-horsepower kerosene

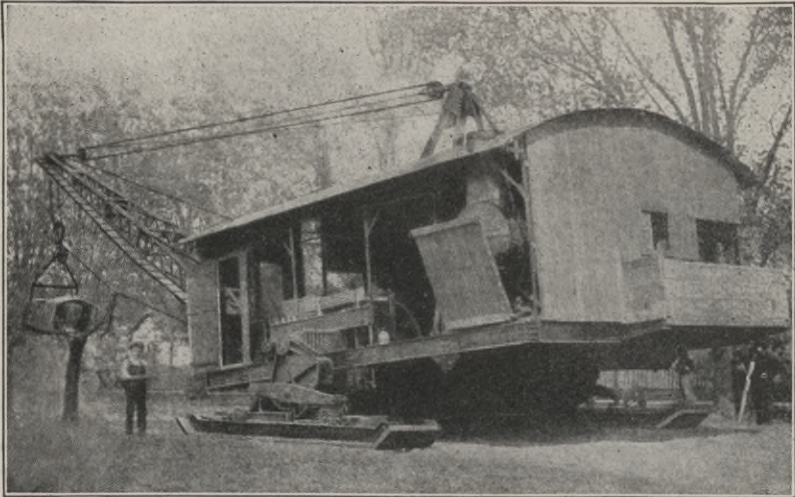

Fig. 43. Walking Drag-Line Excavator  
*Courtesy of Monaghan Machine Company*

engine; the medium, equipped with a 50-foot boom, a 2-yard bucket, and operated by a steam plant; and the largest, provided with a 60-foot boom, a  $2\frac{1}{2}$ -yard or 3-yard bucket, and operated by a steam plant.

**Walking Equipment.** The walking device consists of two large shoes or platforms, one on each side of the central circular support, and two wheel segments or cams, each of which is keyed to the end of a heavy shaft extending across the machine. On the lower end of each cam is pivoted a beam whose ends are chain-connected to the ends of each platform. A view of this mechanism is shown in

Fig. 43. A large gear wheel on the shaft meshes with a pinion on the loading-drum shaft of the main engine. The pinion is controlled by a jaw clutch and brake.

To move the machine, the pinion clutch is thrown in and the engine started. As the shaft revolves, the cams and pivoted beams lift the platforms and swing them forward to a resting place on the ground. As the shaft revolves, the cams move over the upper surfaces of the platforms until they come into contact with the stop blocks, when the motion is stopped, and the machine is moved forward and downward to the surface. When further movement is not desired, the cams are revolved until the beams and platforms are elevated above the ground, and the machine then rests entirely on its circular base, about which it may revolve as a pivot for the purpose of excavating. The pinion is now locked by a brake and the drum clutch released to commence digging.

**Field of Usefulness.** The walking excavator is especially adapted to use on drainage and irrigation projects, where several ditches are to be built in one locality. Ordinarily, when an excavator is through with one job and is ready to commence another channel, it is generally necessary to dismantle the machine, transport the parts to the new site, and reassemble them. This involves a considerable expenditure of time, labor, and money. The walking machine can move over soft, wet, and rough ground and can make sharp turns by revolving about the central support. The machine can be erected at the transportation point where it is unloaded from cars or boats and can walk to the job at the rate of about 3 miles per 10-hour day.

This excavator can be efficiently used in the excavation of wide ditches by moving along the center of the channel and working alternately on opposite sides.

The walking scoop dredge operates at about the same cost as the floating dipper dredge. A machine equipped with a  $1\frac{1}{2}$ -cubic yard dipper, and operated by a 40-horsepower gasoline engine, can handle about 1500 cubic yards of loam and clay per 10-hour day, at an average cost of about 4 cents per cubic yard.





**CULEBRA CUT—THE DEEPEST EXCAVATED PORTION OF THE PANAMA CANAL**

The view shows Gold Hill on the right and Contractor's Hill on the left.

*Courtesy of Panama Canal Commission, United States Government, Washington, D. C.*

# EARTHWORK

## PART II

---

### DREDGES—(Continued)

#### FLOATING EXCAVATORS

**Classification.** The excavators of this division, as the name indicates, move over the water like a boat. They may be classified as to the method of operation as follows: the dipper dredge, the ladder dredge, and the hydraulic dredge.

#### DIPPER DREDGE

Dipper dredges may be classified as to the field of operation as follows: dredges for the excavation of drainage and irrigation channels, dredges with narrow hulls and side floats for digging and maintaining canals, and marine dredges for river and harbor improvements. These three classes comprise many types and sizes of dredges depending upon the service for which the machines are intended. The general arrangement and method of operation of all the types are very similar.

**Construction.** The principal parts of a dipper dredge are the hull, the power equipment, and the excavating equipment. The chief differences in the construction of the different types of dredge are in the design of the machinery, boom operation, and kind of spuds used. Detailed views of dipper dredges equipped with bank spuds and with vertical spuds are shown in Figs. 44 and 45, respectively.

**Hull.** The hull or boat may be constructed of either wood or steel. For marine dredges, where the machine is to be kept in use over long periods of time and where the cost of maintenance is an important item, steel hulls are desirable. For inland operation, as on reclamation work, wooden hulls are preferable on account of availability and economy of material and the ease of assembly and dismantling.

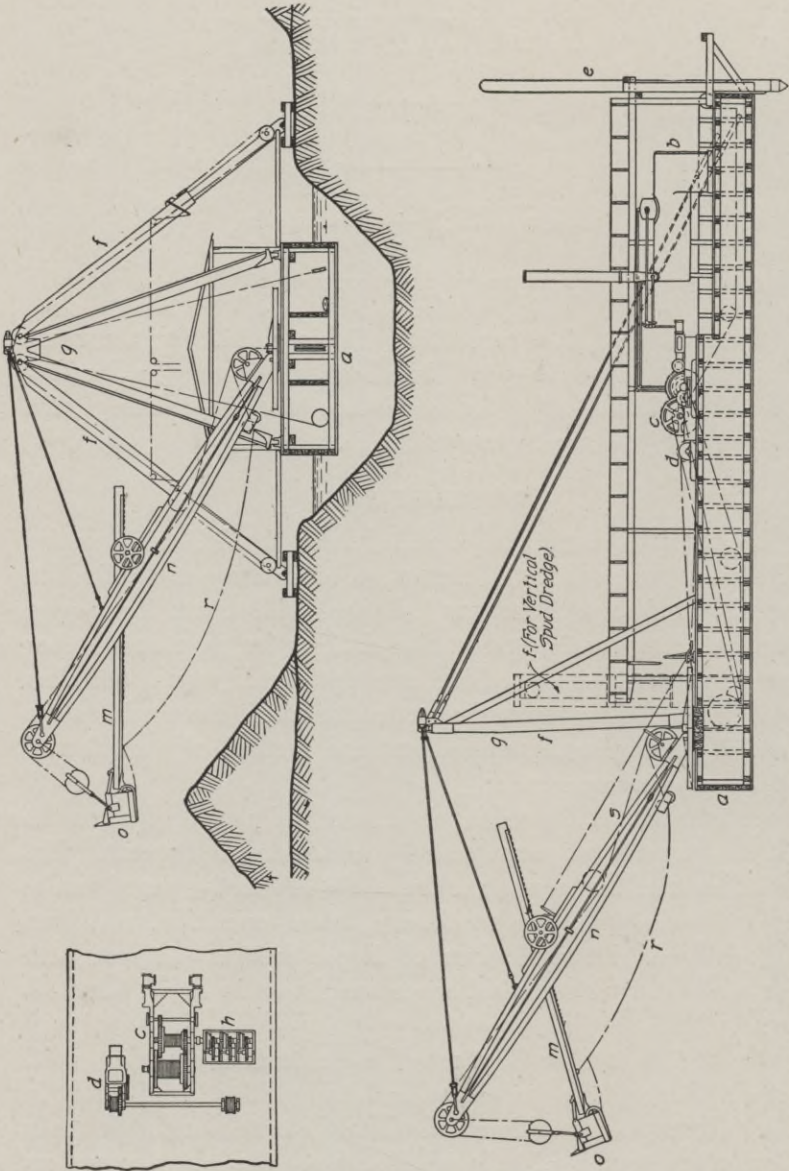

Fig. 44. Diagram of Ditching Dredge with Bank Spuds. a, Hull; b, Boiler; c, Main Engine; d, Swinging Engine; e, Rear Spud; f, Side Spuds; g, A-Frame; h, Spud Hoist; m, Dipper Handle; n, Dipper; o, Dipper; r, Backing Table; s, Hoisting Table

The dimensions of the hull depend upon the size of the machinery, length of boom, capacity of dipper, and width of channel. In the construction of small-sized channels, the width of the hull should be nearly the width of the channel so as to secure the increased stability afforded by the use of bank spuds. The width of the hull should bear some relation to the length of the boom, as the tendency of the dredge to tip sidewise will depend upon the distance of the dipper from the center of the hull. The length of the hull must be sufficient to provide adequate space for the housing of the operating equipment, but principally must be proportioned to balance the weight of the excavating equipment in its various positions. The depth of the hull is governed by the necessary displacement,

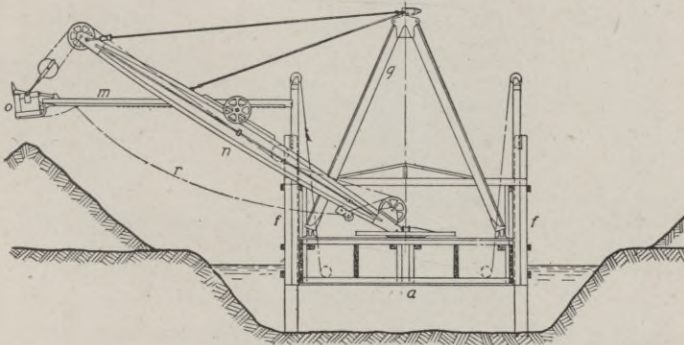

Fig. 45. Ditching Dredge with Vertical Spuds. Letters Have Same Significance as in Fig. 44

but ordinarily should be made with as light draft as possible to provide for shallow excavation.

The wooden hull is generally made up of heavy timbers, strongly braced transversely and longitudinally to form a rigid and strong box. All the outside joints are calked with oakum and tar to make the hull water-tight.

**Operating Equipment.** The operating equipment is of the same general design in all types of dipper dredges. The essential parts are the boiler, the hoisting and backing machinery, the swinging machinery, and the spud machinery. An interior view of a dipper dredge, showing the operating equipment, is given in Fig. 46.

The locomotive type of boiler is generally used on account of its adaptability to various kinds and grades of fuel and its ease

of cleaning. The Scotch marine type is used on the smaller sizes of dredge and under favorable working conditions is perhaps more economical of fuel, more durable, and safer than the locomotive type, but under the usual conditions of poor fuel, hard water, and severe loading, the latter generally renders the more efficient and economical service. A working pressure of 125 pounds is generally used for the operation of the dredge. A feed-water heater should be used to soften and purify the boiler water in localities where hard or alkali water exists. A duplex pump and injector supply

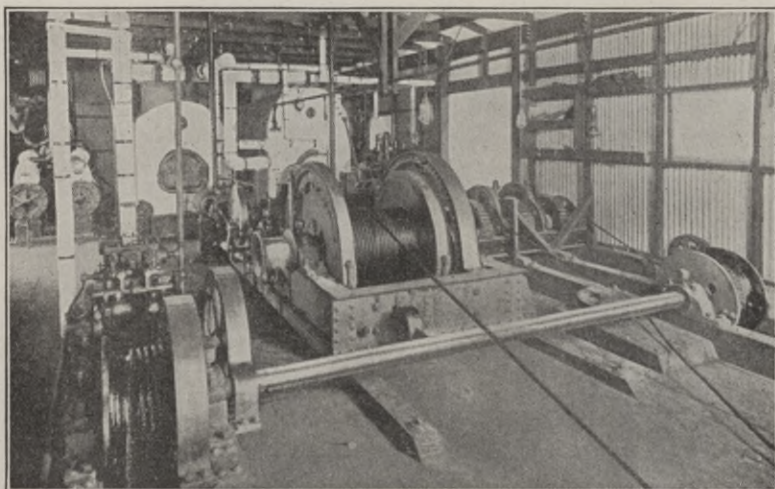

Fig. 46. Interior of Dipper Dredge Showing Operating Equipment

the feed water to the boiler. The water may be pumped directly from the channel or from neighboring wells.

The hoisting and backing machinery are of three different types, depending on the method of transmitting the power: single, double, and triple hitch. These three classes are provided for by the use of a single, a two-part, or a three-part hoisting line. In the first class, the power developed by the engine is compounded through gears, the hoisting rope being connected directly to the dipper handle. In the two latter classes, the power is compounded by means of a sheave attached to the bail of the dipper. The main engine is of the double-cylinder, horizontal, nonreversible type, mounted on a braced structural-steel bed. There are two

drums, one for the hoisting cable and the other for the backing cable. The drums are generally grooved to hold the first layer of cable in place and are controlled by outside friction bands, which are operated by steam-actuated rams attached to the spokes of the large gearwheel.

The swinging machinery usually consists of an independent, double-cylinder, horizontal, reversible engine, which is geared to a shaft carrying a drum at each end for direct leads to the swinging circle. The engine is controlled by a single, balanced throttle

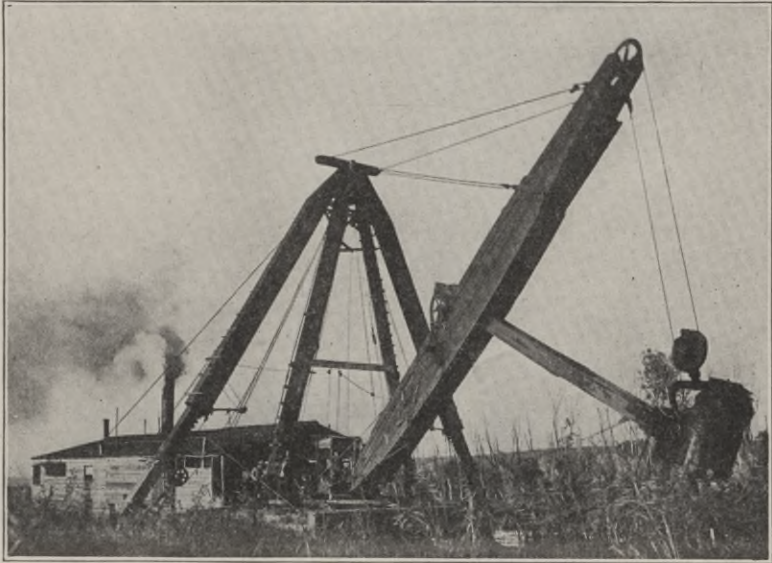

Fig. 47. Dipper Dredge in Operation

valve. On the smaller size dredges, the swinging mechanism consists of friction drums, gear-driven from the main engine.

The spuds are leg braces which are used to provide stability for the dredge during its operation. One is located in the center of the rear end and one on each side near the front of the hull. Inclined bank spuds are used when the channel is narrow and the hull is nearly the full width of the excavation. As will be seen from an inspection of Fig. 47, the upper ends of the spuds are attached to the head block of the A-frame and the lower ends sustain large timber platforms which transmit the pressure directly to the soil.

Short braces connect the lower ends of the spud timbers with the sides of the hull, near the feet of the A-frame. Vertical side spuds are used on the larger sizes of dredge for wide channel and harbor work. In this case, the lower ends of the spuds bear directly on the bed of the stream. The rear spud is always vertical and is used to prevent the hull from swinging about during the operation of the excavating equipment. Each spud is a single, solid timber which moves up and down in an iron or timber box, or guide frame. Teeth on a rack fastened to the lower side of the spud, engage a pinion on the lower side and at the end of the guide frame.

The spuds are raised and lowered by means of cables passing over sheaves and thence to special drums. These drums are generally mounted on a separate base, and their shaft is connected to the end of the backing-drum shaft by a jaw clutch, which is disengaged when the spuds are not being operated. In the larger size dredges an independent engine is placed near each spud and operates the spud by a direct gear connection.

**Excavating Equipment.** The excavating equipment consists of the boom, dipper handle, and dipper.

The boom is generally shaped like a fish-bellied beam and may be made of either steel or wood. It is made in two sections so spaced that the dipper handle may move between them. For long booms, a trussed type is used to secure lightness with the requisite strength. For long booms and dippers of large capacity, a trussed-steel beam is preferable. The boom at its center should have a depth equal to about  $\frac{1}{10}$  of its length. The length of the boom should be about  $1\frac{1}{2}$  times the width of the hull with vertical spuds, and up to about twice the hull width when bank spuds are used. The upper end of the boom is connected to the yoke at the top of the A-frame by wire cables. At the outer end also is the sheave over which the hoisting cable passes on its way from the dipper to the fair-lead sheaves, at the lower end of the boom, and thence to the hoisting drum. The lower end of the boom is pivoted to the swinging circle or upper sections of the base casting.

The swinging circle is a steel circular framework which is located just above the deck or several feet above the deck when it is necessary to secure sufficient swinging power for long booms. The diameter of the circle should be sufficient to give a direct pull from the drums

of the swinging engine and should not be less than  $\frac{1}{6}$  of the horizontal reach of the boom.

The dipper handle is universally made up of a solid timber reinforced with steel plates. Upon the lower side of the handle is placed the steel racking which meshes with the pinion of the shipper shaft located on the upper side of the boom, near its center. The length of the handle should be made about  $\frac{2}{3}$  that of the boom. The dipper is attached to the lower end of the handle by means of a pin connection, so that the pitch of the cutting edge may be changed to suit different classes of materials.

The dipper which is used for the dredging of ordinary soils is of the same type as that used on steam shovels. A reference to Fig. 47 will show the general shape and construction. The front is made of a heavy manganese-steel plate which is riveted to the side plates. The back is a single steel casting which is also riveted to the side plates. The bottom or door is hinged to the back and is provided with a latch which is tripped by a rope extending to the cranesman's platform at the right side of the boom. The size or capacity of the dipper varies from  $\frac{1}{2}$  to 15 cubic yards; but  $1\frac{3}{4}$  yards is the size generally used in work of average magnitude, and  $3\frac{1}{2}$  yards for large channels and work of great magnitude. Large sea-going dredges equipped with dippers of from 5- to 10-yard capacity have been used for several years on harbor improvements, and in 1914 two mammoth dredges, each equipped with 15-yard dippers, were put into operation on the Panama Canal for the removal of the slides.

For the excavation of loose sand and gravel, the clam-shell and orange-peel buckets are very efficient. These are single-line buckets, and the backing cable would not be used. The details and dimensions of a standard make of clam-shell and orange-peel buckets are given in Figs. 48 and 49, respectively.

**Method of Operation.** The method of operation of a dipper dredge is very similar to that of a steam shovel, which has been previously described in the section on Power Shovels. The crew of a dipper dredge consists of an engineer, a cranesman, a fireman, and from 2 to 4 laborers, for each shift. A dipper dredge is ordinarily run on two 11-hour shifts, and hence two complete crews are necessary. The engineer operates the levers and brakes which



control the motions of hoisting, backing, swinging, and moving the dredge. The cranesman stands on a little platform just above the swinging circle on the right side of the boom, and controls the operation of the dipper as to loading and dumping. The fireman supplies the boiler with fuel and has general charge of the oiling and care of the machinery. The laborers supply the dredge with fuel, oil, and supplies, and perform the necessary general work around the machine.

As the dipper and dipper handle slide downward toward the face of the excavation, the bottom of the dipper closes of its own weight and latches. When the dipper reaches the bottom of the channel, the engineer applies the friction clutch to the hoisting drum and throws a lever, starting the drum to wind up the hoist line. This pulls the dipper upward, and the forward motion is regulated by the tension on the backing line. As soon as the dipper is clear of the surface and has completed the cut, the engineer throws the hoisting drum out of gear and sets the friction clutch, thus bringing the dipper to a stop. Then the swinging engine is started and the boom is swung around to one side until the dipper is over the dumping place. With a foot brake, the engineer sets the friction clutch and stops the revolution of the swinging drums. The cranesman then pulls the latch rope, and this opens the latch, releasing the bottom which drops and allows the dipper contents to slide out. The engineer then releases the friction clutch and reverses the swinging engines, pulling the boom and dipper back into position for the next cut. As the boom swings around, the engineer slowly releases the friction clutch of the hoisting and backing drums and simultaneously slightly pulls in the dipper toward the dredge and lowers it into the cut, so as to produce a prying action. As the latter part of the drop is reached, the backing cable is released gradually and the dipper allowed to move forward toward the face of the cut. The time required for a complete cycle of operations depends upon the skill of the operator and the nature of the material excavated. The average time for a complete swing should be about 40 seconds. The most efficient results are secured when the operations are made smoothly and uniformly so as to cause the least amount of lost motion and wear and tear on the machinery.

After the entire face of the cut has been removed within reach

of the dipper, the dipper is raised and the boom slowly swung from side to side to relieve the pressure on the spuds. With the boom remaining in a central position, the spud hoists are put in operation and the spuds raised from their resting places, thus allowing the hull to float ahead toward the face of the cut. With each move,

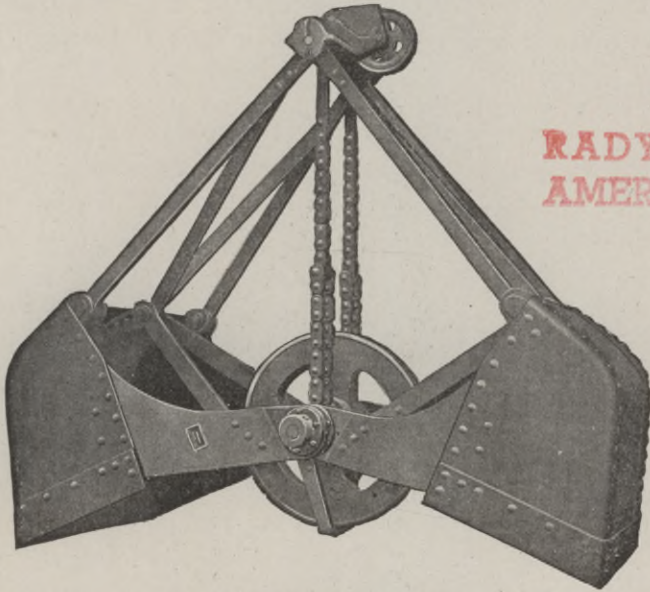

DAR  
RADY POLONII  
AMERYKAŃSKIEJ

Fig. 48. Typical Clam-Shell Bucket  
Courtesy of The Hayward Company, New York City

CAPACITY	APPROX. WEIGHT (lb.)	CLOSED			OPEN	
		Height Ft. In.	Length Ft. In.	Width Ft. In.	Height Ft. In.	Length Ft. In.
1½ cu. yd.	4400	7 8	6 2	4 2	8 8	9 0
1¾ cu. yd.	4800	7 8	6 2	4 6	8 8	9 0
2 cu. yd.	6800	8 6	6 11	4 10	9 6	9 9
2½ cu. yd.	7800	8 9	7 0	5 3	9 9	10 0
3 cu. yd.	9000	8 9	7 0	6 2	9 9	10 0

the dredge makes an advance of about 6 feet. The spuds are then lowered by releasing the drums, or by reversing gears, and the dredge is ready for the next cut.

**Cost of Operation.** The cost of operation of a dipper dredge will depend on the size and type of dredge used, the character and

magnitude of the work, the kind of material to be excavated, the efficiency of the operator, etc.

*Illustrative Example.* As a typical case, the following is a detailed statement of the expense connected with the operation

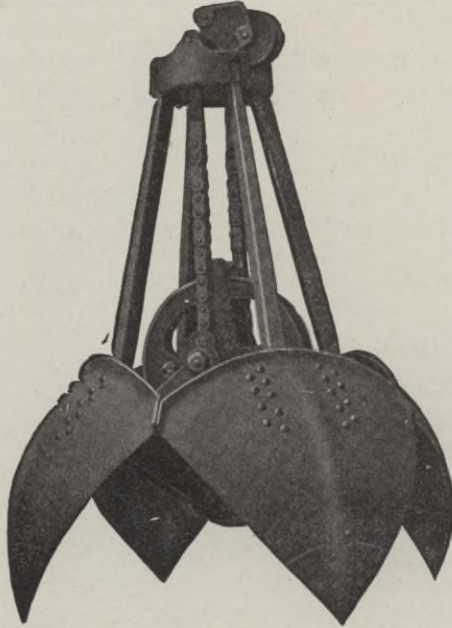

Fig. 49. Typical Orange-Peel Bucket  
Courtesy of The Hayward Company, New York City

CAPACITY (Cu. Ft. and Cu. Yd.)	APPROX. WEIGHT (lb.)	CLOSED		OPEN	
		Diameter Ft. In.	Height Ft. In.	Diameter Ft. In.	Height Ft. In.
4 cu. ft.	950	3 0	4 8	3 9	5 1
5 cu. ft.	1000	3 2	4 9	3 11	5 3
7 cu. ft.	1100	3 6	5 0	4 3	5 7
9 cu. ft.	1200	3 10	5 2	4 7	5 10
12 cu. ft.	2200	4 3	6 2	5 2	6 10
15 cu. ft.	2350	4 7	6 6	5 6	7 2
21 cu. ft.	3800	5 1	7 6	6 3	8 4
1 cu. yd.	4200	5 8	7 10	6 10	8 9
1 $\frac{1}{4}$ cu. yd.	4600	6 0	8 0	7 3	9 0
S 1 $\frac{1}{2}$ cu. yd.	5350	6 4	8 2	7 8	9 4
1 $\frac{1}{2}$ cu. yd.	7750	6 4	9 4	7 10	10 4
2 cu. yd.	8500	7 0	9 10	8 6	11 0
2 $\frac{1}{2}$ cu. yd.	9500	7 8	10 2	9 3	11 6
3 cu. yd.	10500	8 0	10 4	9 7	11 10
S 4 cu. yd.	12500	8 10	10 10	10 6	12 6

of a dipper dredge, equipped with a  $1\frac{1}{4}$ -yard dipper and a 70-foot boom, on the construction of a drainage channel along the bottom lands of a central western river. The soil is loam and clay with no stone and a small amount of stumps to be removed. The channel will be assumed to contain about 2500 cubic yards per station of 100 feet. Two crews work on 11-hour shifts and live on a houseboat, which floats along behind the dredge. The following statement is based on the average output for an 11-hour shift.

#### Operating Cost of Dipper Dredge

*Labor:*

1 engineer,	@ \$100 per month	\$4.00	
1 fireman,	@ \$60 per month	2.40	
1 cranesman,	@ \$75 per month	3.00	
2 laborers,	@ \$50 each per month	4.00	
1 cook,	@ \$40 per month	1.60	
Total labor cost, per day			\$15.00

*Fuel and Supplies:*

2 tons coal,	@ \$6.00	\$12.00	
Oil, waste, grease, etc.		2.00	
Total cost of fuel and supplies			\$14.00

*General and Overhead Expenses:*

Board and lodging for crew of 10 men, per day		\$3.50	
Repairs and incidentals		4.00	
Interest on investment (6% of \$10,000)*		1.50	
Depreciation (10% of \$10,000)*		5.00	
Total general expense			\$14.00

Total Cost of Operation for 11-hour Shift		\$43.00
Average Output (cu. yd.)	1200	
Unit Cost of Dipper Dredging, per cu. yd., $\$43.00 \div 1200 =$		00.036

**Field of Usefulness.** The dipper dredge is the best known and most popular type of excavator used in the construction of drainage channels. Most of this class of work must be done on low, swampy land, where it is difficult for anything but a boat to move about. The dipper dredge with its large bearing area and shallow draft is especially adapted to operating under these conditions. Where the soil is too soft to support the smaller types of dry-land excavators, and a considerable number of large stumps must be removed, the smaller lateral ditches of a drainage system

\* Based on 200 days in a year and a 10-year life.

can be excavated more economically with a small dipper dredge than with any other type of excavator.

In many cases it is cheaper to use one of the smaller sizes of dipper dredge (having a 16-foot width of hull, a 40-foot boom, and a 1-yard dipper), and to excavate a ditch twice the necessary size, than to use a smaller machine of another type to dig a channel the size required. The most economical size of channel for the operation of a dipper dredge is one with a bottom width of 40 feet and an average depth of 10 feet. When the cross-section of the channel becomes greater than this, the cost increases until a channel having a cross-sectional area of about 1200 square feet is reached, when the use of the dipper dredge is no longer efficient or practicable.

The channel which a dipper dredge excavates is rather uneven in cross-section and does not have smooth side slopes and true

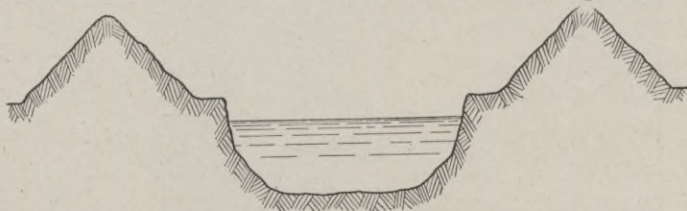

Fig. 50. Section of Ditch Constructed by Floating Dipper Dredge

bottom grades. The form of ditch excavated by this machine is shown in Fig. 50. After several years' use the channel will assume a general semicircular section. In shallow channels, or those where the stream flow is small during a large part of the year, considerable reduction of the cross-section may be caused by the deposition of silt and débris and the growth of vegetation.

The dipper dredge is one of the most versatile of modern excavators as it can excavate all kinds of soil from silt to loose rock, pull stumps, remove boulders, bridges, and other obstructions, drive piling, build earthen dams, and perform many other duties which may arise during the course of operation.

#### LADDER DREDGE

**General Characteristics.** The elevator or ladder dredge has been little used in this country, except in the West and in Alaska for placer mining, but which is very popular and of nearly universal

use in Great Britain and on the continent. Since 1900 the ladder dredge has been used on large waterway construction; notably the Chicago Drainage Canal, the New York State Barge Canal, and the Panama Canal.

**Construction.** The ladder dredge consists of a hull on which is placed the operating machinery and the excavating equipment. The operating machinery includes engines for the operation of the elevator, the belt conveyors, the hydraulic monitor, the spuds, etc. The excavating equipment comprises the ladder frame and ladder, and the means of disposal of the excavated material, con-

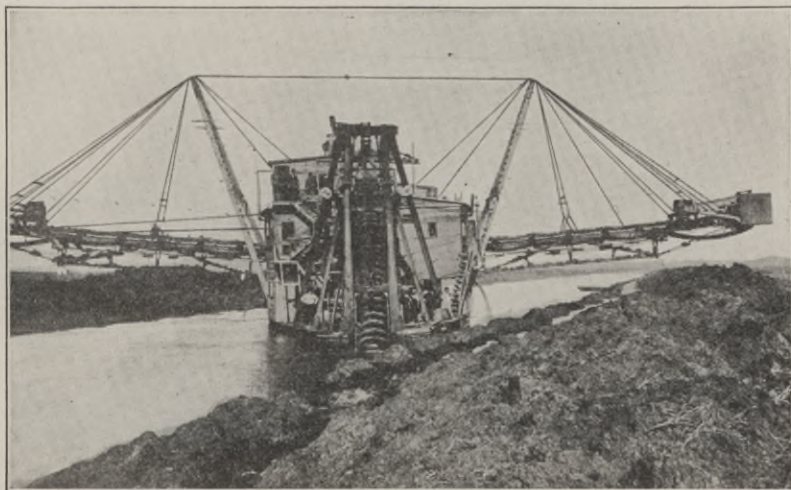

Fig. 51. Elevator Dredge Excavating Large Drainage Ditch

sisting either of a hopper and a discharge channel, or of belt conveyors. The placer dredge is provided with a revolving screen and distributing channels for the separation of the gold from the gravel. A general view of a ladder dredge excavating a large drainage channel is shown in Fig. 51. A detailed view of an electrically operated placer dredge is shown in Fig. 52, and detailed views of a ladder dredge especially designed for canal excavation are given in Fig. 53.

The hull or barge is shaped like a rectangular box and is generally built of heavy timbers. The hull may be built as one structure with a well through the bow for the passage of the ladder,

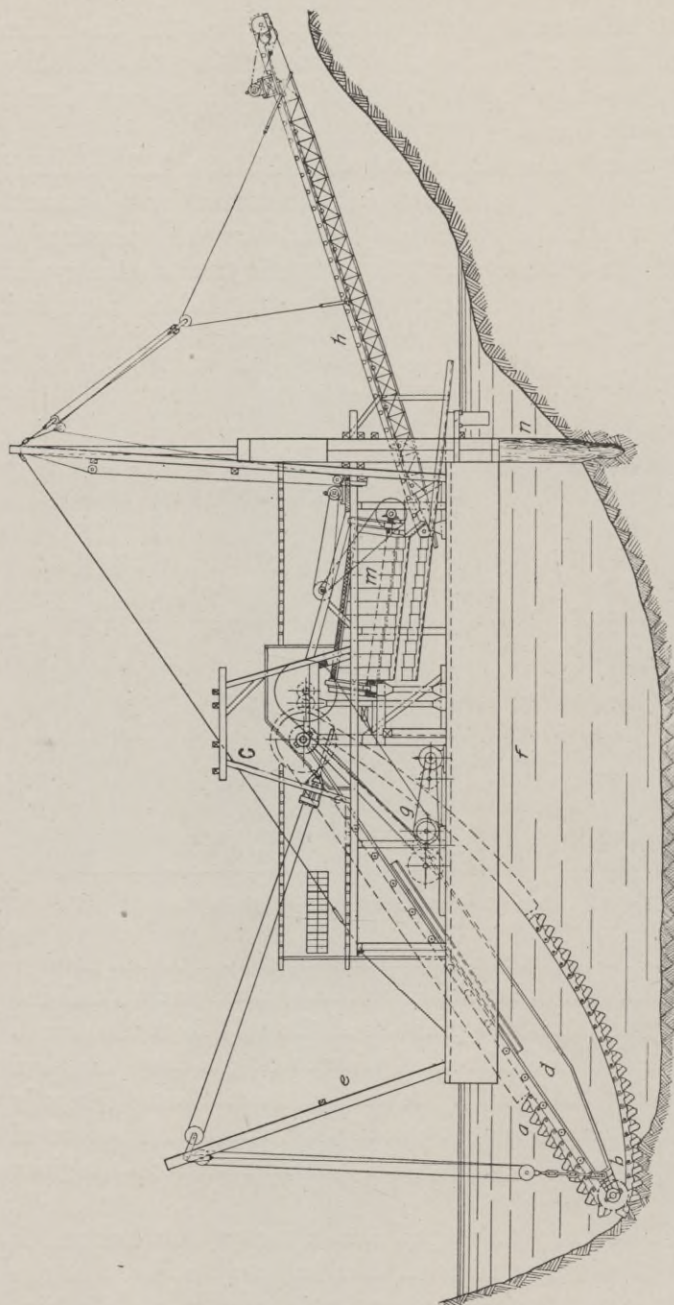

Fig. 52. Sectional View of Electrically Operated Placer Dredge. *a*, Ladder; *b*, Lower Tumbler; *c*, Upper Tumbler; *d*, Ladder Frame; *e*, Ladder Gentry; *f*, Hull; *g*, Ladder and Screen Operating Machinery; *h*, Belt Conveyor; *m*, Screen; *n*, Spud  
*Courtesy of The Bucyrus Company, South Milwaukee, Wisconsin*

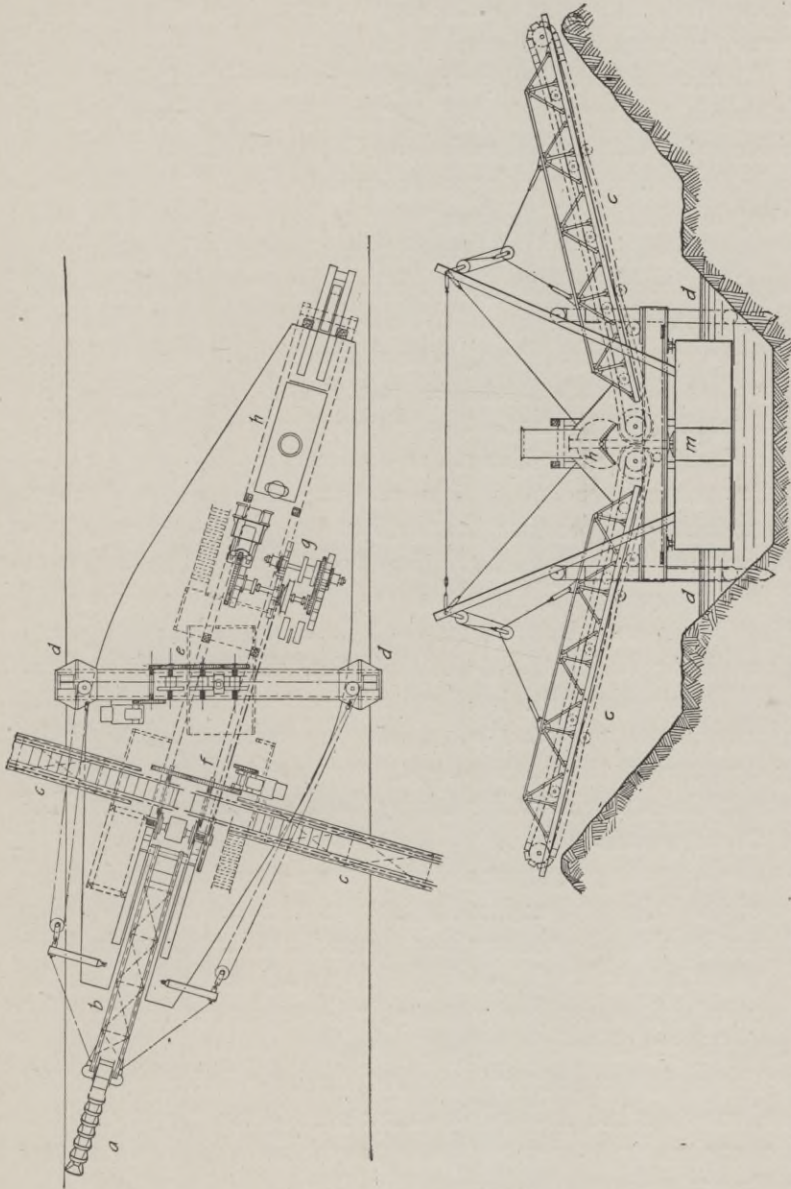

Fig. 53. Elevator Dredge for Canal Excavation. *a*, Ladder; *b*, Ladder Frame; *c*, Belt Conveyors; *d*, Spuds; *e*, Swinging Machinery; *f*, Conveyor Operating Machinery; *g*, Ladder Operating Machinery; *h*, Boiler; *m*, Hull



or as two members with a space between. The latter type is sometimes used so that the excavator may be passed in sections through narrow structures such as canal locks.

The size of the hull depends upon the capacity of the dredge. The length, which varies from 50 feet to 125 feet, is generally about five times the width, which varies from 30 feet to 50 feet. The draft of a ladder dredge in working condition is from 4 feet to 6 feet and the depth of hull should be from 6 feet to 10 feet. The hull should be strongly braced both transversely and longitudinally and made watertight by well-calced joints of the outer planking. A few hulls have been made up of 2 steel-framed pontoons connected by steel cross-frames. For permanent work this type of hull is better than the wooden structure, as it is more rigid and durable.

**Operating Equipment.** The power for the operation of a ladder dredge may be either steam or electricity.

Several independent engines are required for the different performances of operating the ladder, the belt conveyors, the revolving screen, the spuds, swinging the hull, etc. These separate engines are uneconomical in the use of steam and hence it is often advisable to generate electric power by a steam plant and operate each engine by an individual electric motor. When several dredges are working in the same locality, it is most economical to locate a power plant on shore and to transmit the electric current by wires to the motors on the machines. An economy in the use of electric power is the saving of hull room by the elimination of the boiler and steam engines.

The operating equipment for a steam-operated dredge consists of the boiler and engines for the various motions. The boiler is generally of the Scotch marine type and is mounted on the floor of the hull in the rear of the dredge. It should be of more than the theoretical estimated capacity to supply the engines and be operated at a working pressure of about 125 pounds.

The engines are of the horizontal, double-cylinder type, which have been described in detail for steam shovels and dipper dredges. These engines are gear-connected to the drum or winch machinery. The drums are controlled by outside friction clutches actuated by small rams. Independent gear drives for the revolving screen and ladder are often operated from the main engine by belt and pulley

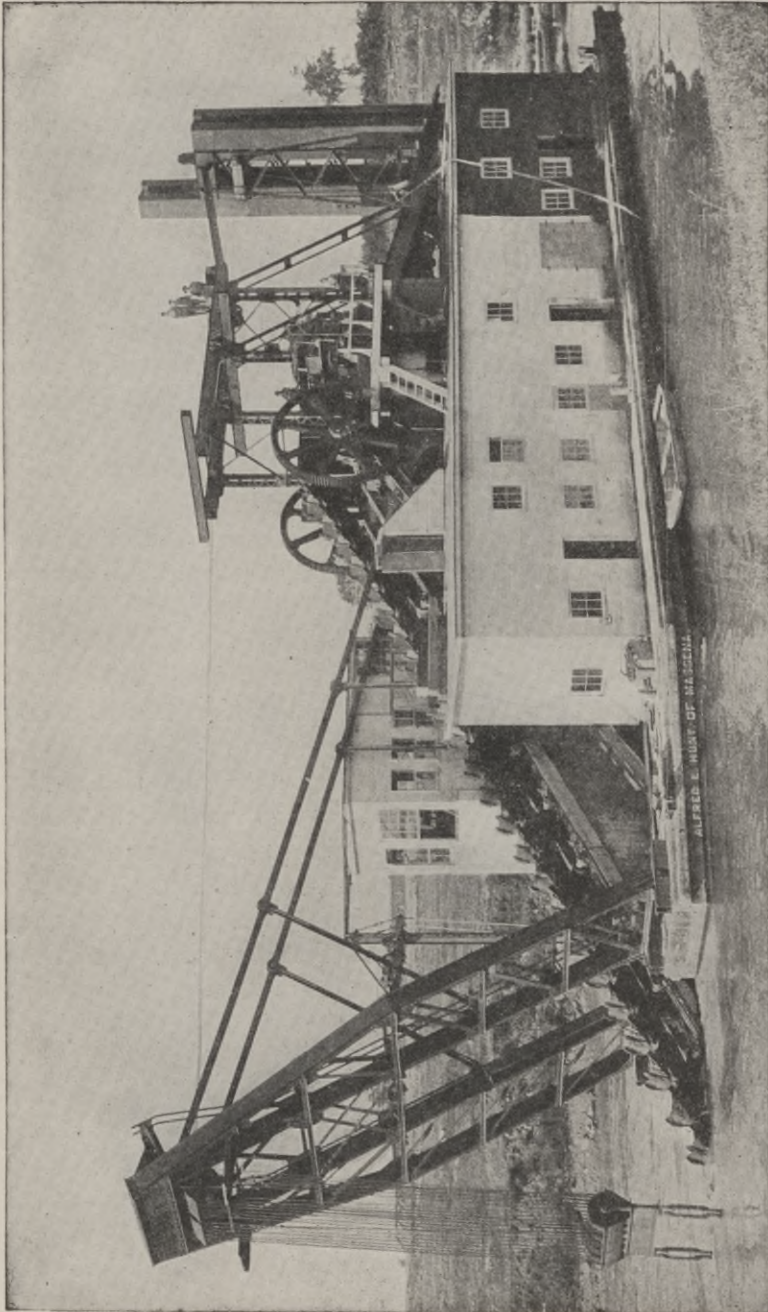

Fig. 54. Ladder Dredge in Operation on Canal Construction

connections. However, separate engines are generally used for the operation of the spoil conveyors and spuds.

A centrifugal pump, driven by a separate engine, is generally used to furnish water for a hydraulic monitor, for the hoppers and revolving screen, and for the perforated pipes which extend along the sides of the belt conveyor for cleansing purposes. Steam pumps of standard type are used to supply the condensers, feed-water heaters, and boilers with necessary water.

When electric power is used, individual motors are generally mounted on the winch drum or drive frame and gear-connected by a pinion. These motors may receive current from a generator operated by a steam plant on the dredge or from a steam or water power plant located on the shore.

**Excavating Equipment.** The excavating equipment consists of the gantry, ladder frame, and chain and buckets.

The gantry is an inclined framework composed of timber or structural-steel members strongly framed together. The frame is placed at the bow of the hull and is held in position by braces extending to the front end of the hull. Sheaves at the top of the frame carry the cables which support the outer and lower end of the ladder frame. The gantry has a height of from 15 feet to 30 feet, Fig. 54.

The ladder frame is generally a structural-steel framework shaped like the boom of a dipper dredge. The length of the frame varies with the size and capacity of the dredge and the depth of the proposed excavation. The upper end of the ladder frame is hinged to the upper tumbler shaft, while the lower end is suspended by heavy tackle from the gantry. The frame carries tumblers or large, hexagonal, steel barrels at its ends. The upper tumbler is revolved by power supplied from the main engine through a shaft, while the lower tumbler is revolved by the friction of the bucket chain.

The chain is composed of a continuous series of buckets, links, and connecting pins. The buckets are cup-shaped and made of three sections, strongly riveted together. They have capacities varying from 3 cubic feet to 13 cubic feet. They are placed in "open" or "close" order—that is, consecutively, or with open links between adjacent buckets—depending upon whether the soil is soft or hard.

The movement of the bucket chains is slow and uniform and is such as to feed from 15 to 20 buckets per minute into the bed of the stream. Fig. 55 shows a section of a chain with "close" order and Fig. 54 shows the buckets provided with teeth for the excavation of dense, hard materials.

One or two spuds are generally placed at the stern of the hull to provide for the stability of the dredge and for its lateral movement. They are usually composed of a single timber with a pointed shoe at the lower end and are operated by separate engines of the type used on the floating dipper dredge.

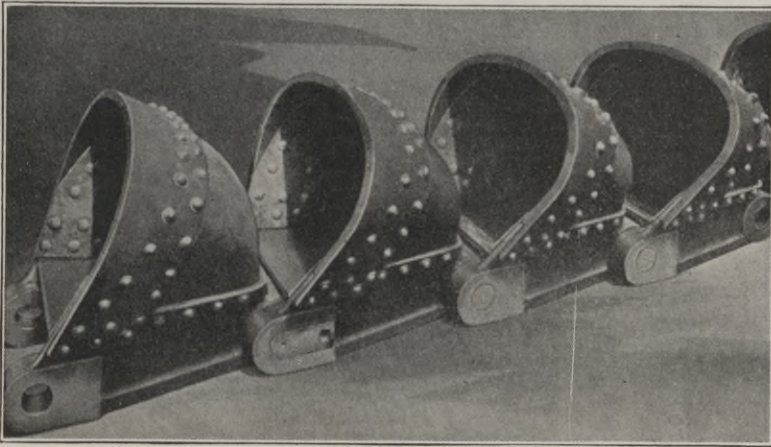

Fig. 55. Section of Chain Used on Ladder Dredge

**Material Distributing Machinery.** The disposition of the excavated material depends upon the character of the work. In placer-mining operations, the dredge is provided with a hopper into which the material falls. Then the material passes through a revolving screen and upon a screen trough where the gold is collected by amalgam plates. In the excavation of canals or stream beds the materials pass from the hopper into a chute or trough which discharges into barges, as shown in Fig. 56, or directly from the bucket chain to belt conveyors which carry it to the spoil banks along either side of the channel, Fig. 51. In some cases, when the material is to be conveyed for some distance, the con-

veyor is placed at the stern of the hull and discharges into a series of other conveyors supported on pontoons.

**Method of Operation.** The outer end of the ladder is lowered until the bucket chain is in contact with the bed of the stream. Each bucket in the revolution of the chain, removes a slice of material as it comes into contact with the soil. At the top of the ladder, the buckets in turning over the upper tumbler, dump their contents into a hopper which discharges into a screen or directly

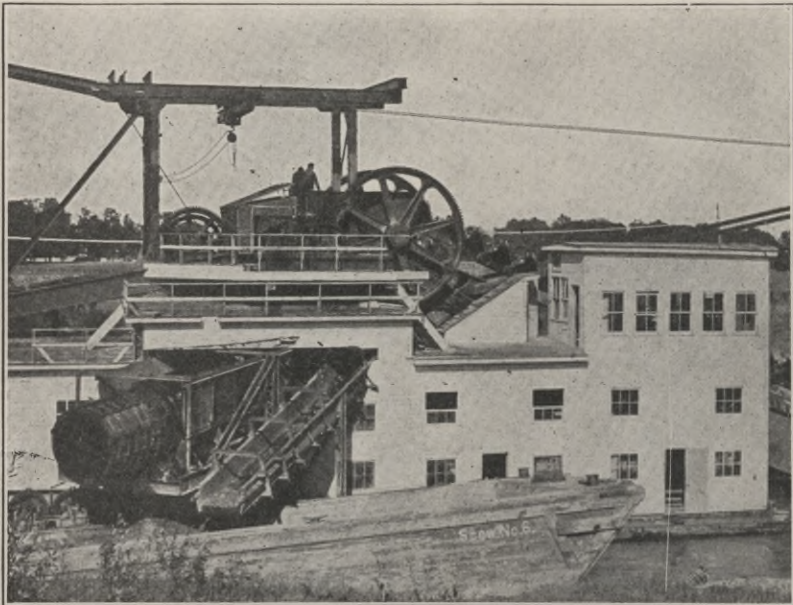

Fig. 56. Ladder Dredge Provided with Trough for Discharging Excavation into Barges

upon a belt conveyor. The ladder is gradually lowered as the excavation proceeds.

The dredge is swung from side to side across the channel by wire cables attached to trees along the shore and to winch drums on the hull. To move the dredge ahead the spuds are alternately raised and lowered as the dredge is swung from one side to the other.

When high banks are to be removed it is customary to use a large hydraulic monitor, which is placed near the ladder frame

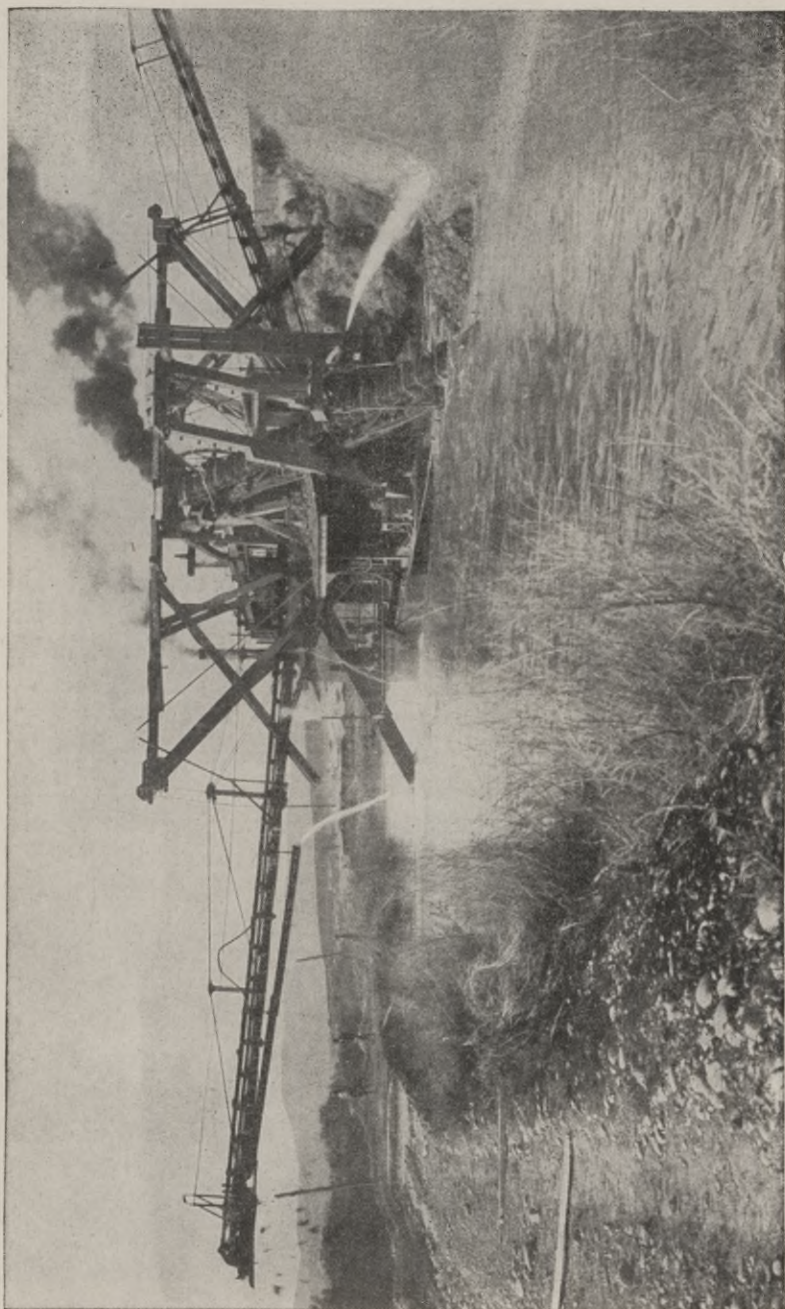

Fig. 57. Elevator Dredge Excavating Large Irrigation Canal

and above the deck of the hull at the bow. Fig. 57 shows an elevator dredge, equipped with a monitor, excavating a large irrigation canal in the West.

The machinery of the dredge is usually controlled by an operator, who is located in a small cabin placed near the bow and above the machinery house. Besides the operator there are required an engineer, who has general charge of the machinery, a fireman who runs the boiler of the steam equipment, an oiler, a deck hand for general service on the dredge, a man who has charge of the operation and control of the conveyors, and one or more men who have charge of the shore conveyors or barges.

Each dredge requires the service of 1 tug and from 4 to 8 scows, depending upon capacity of the dredge, size of channel, character of materials, etc. The scows may be of steel or timber and are generally of the bottom-dumping type with several independent compartments.

**Cost of Operation.** As elevator dredges are generally built to meet special conditions of service, it is difficult to give any accurate statement of the average cost of operation. However, in order to suggest the cost of operation in canal excavation, the following statement of the use of ladder dredges in the construction of an irrigation canal on a Reclamation Service project is given.

*Illustrative Example.* The channel had a total length of about 20 miles and in many places the banks were high on one or both sides. On fills and shallow cuts, bulkheads were built along the right of way on the lower bank to keep the wet material from flowing on to adjacent fields. The material excavated varied from a loose gravel to hard pan, which in places had to be blasted.

The dredge used was a Bucyrus ladder dredge, equipped with steam power and a  $3\frac{1}{2}$ -cubic-foot continuous bucket chain. The hull was built of timber, with a length of 82 feet, a width of 30 feet, a depth of 6 feet 6 inches, and drew 5 feet of water. Steam was furnished by 2 locomotive-type boilers, 44 inches in diameter and 18 feet long, and having a rated capacity of 80 horsepower. The main drive and ladder hoist were driven by an 8×12-inch double horizontal engine of 70 horsepower. The winch machinery for operating the spuds and swinging the dredge was driven by a 2-cylinder, 6×6-inch, double horizontal engine of 20 horsepower.

The belt conveyors were operated by two 7×10-inch, single-cylinder, center-crank, horizontal engines of 18 horsepower. A No. 1 Hendy hydraulic giant was mounted on the bow of the dredge and water was forced through it by a 2-stage, 6-inch, centrifugal pump, belted to a 10×12-inch, single-cylinder, upright engine of 80 horsepower. The giant was used to remove banks above the water level and beyond the reach of the bucket chain. Two belt conveyors, one on each side of the dredge, were used for the disposal of the excavated material. Each conveyor was 72 feet long and consisted of a steel framework supporting a 7-ply, 32-inch, rubber conveying belt. Fig. 57 shows the dredge in operation.

The operating force consisted of 8 men and 4 horses. Following is a schedule of the labor expense per day.

**Expense Schedule of Daily Labor**

LABOR	DAY RATE
Superintendent	\$7.50
Operator	5.00
Engineer	4.67
Spudman	3.83
Fireman	3.33
Oiler	3.00
Deckman	2.50
Man-and-team	4.50

The following tabulation gives the total and unit cost of the work.

**Cost of Work by Ladder Dredge**

(Excavation of 929,723 cu. yd.)

DIVISION	Cost	
	Total	Unit (per cu. yd.)
Labor (dredge)	\$29,960.63	\$0.030
Labor (spoil bank)	31,159.06	0.034
Fuel	33,043.07	0.036
Plant Maintenance	52,327.40	0.057
Plant Depreciation	41,432.53	0.045
Total	\$187,922.69	\$0.202
Engineering and Administration	28,154.41	0.031
Grand Total	\$216,077.10	\$0.233

**Field of Usefulness.** The elevator dredge has been universally used in Europe for harbor and canal excavation and notably on



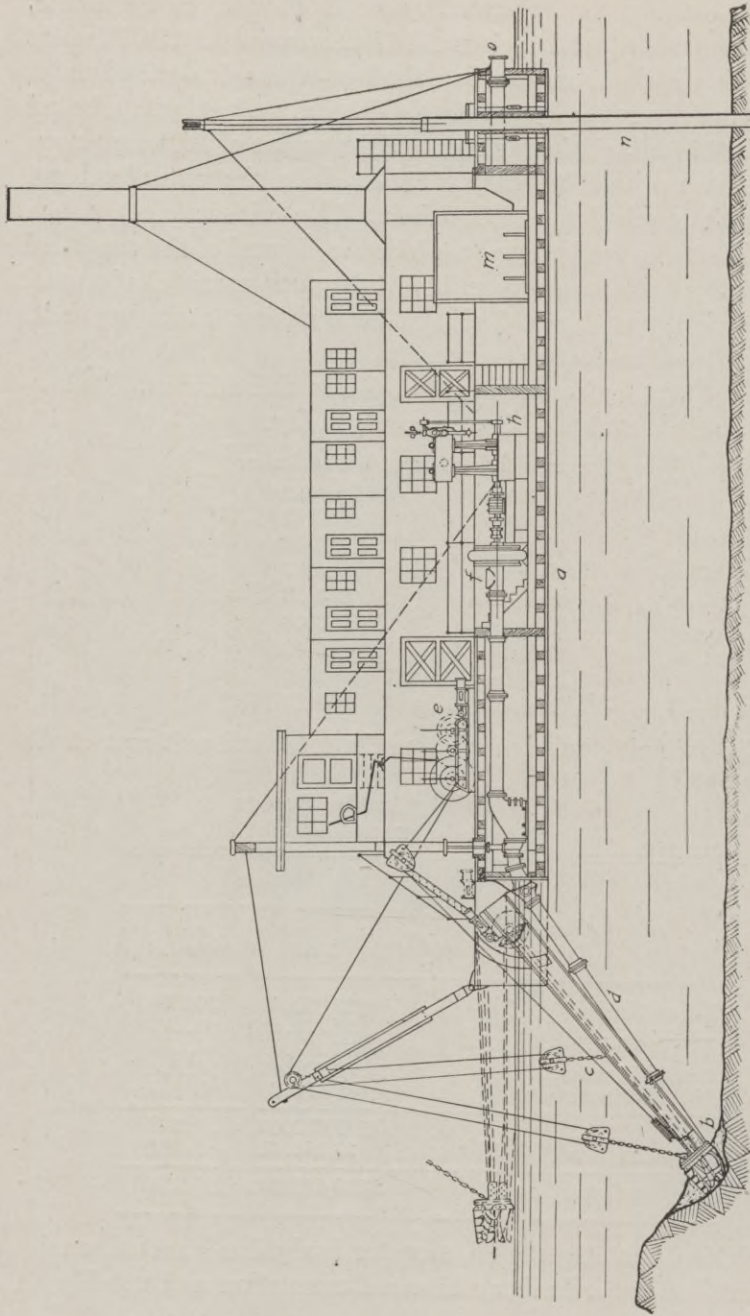

Fig. 58. Sectional View of Hydraulic Dredge. a, Hull; b, Cutter; c, Ladder; d, Suction Pipes; e, Main Engine; f, Discharge Pipe; g, Spuds; h, Pump; i, Boilers; m, Boilers; n, Spuds; o, Cutter  
*Courtesy of the Norbom Manufacturing Company*

the construction of the Suez Canal, the Panama Canal, and the New York State Barge Canal. In this country the ladder dredge has not come into general use on account of the high initial cost of the plant. The average American contractor prefers to use a dipper dredge costing about \$40,000, rather than a ladder dredge requiring an investment of about \$100,000, in order that he may secure immediate results on a less capital charge.

The elevator dredge is efficient in the excavation of all classes of material from silt to hard pan and the softer stratified rocks. This dredge cannot work to advantage in narrow channels, and hence is not adapted to the excavation of small canals and ditches or the dredging out of narrow rivers. In such cases the dipper dredge should be used. When the banks are high, difficulty is experienced in depositing the excavated material. When the banks are low, dikes or bulkheads must be erected to prevent the soft material from flowing back into the channel or over adjacent land. When the sides of the channel are to be sloped, the bucket chain must be gradually raised and lowered as the dredge is swung over to the side. Trouble is often experienced in the operation of the spoil conveyors and water jets are required to keep them clean. The excavated material is generally so wet that the deposition of the material in uniform spoil banks along the shore is a difficult matter.

The proper sphere of usefulness of the ladder dredge is in large canal, river,

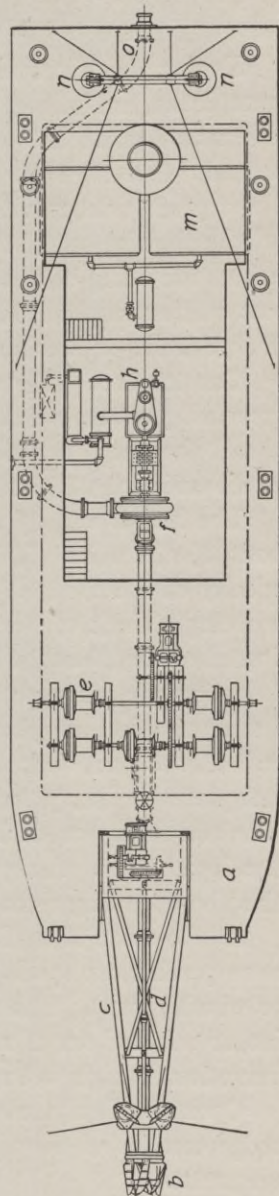

Fig. 59. Plan of Hydraulic Dredge. For significance of letters, see Fig. 58

and harbor work, where there are wide, long reaches and a large amount of dense material to be removed. In such cases, the scow method of removal should generally be used.

#### HYDRAULIC DREDGE

During the last twenty years, the great improvements in the rivers, lakes, and harbors of this country have made a demand for an excavating machine of great power, capacity, and efficiency in the removal of large quantities of the looser soils. The reclamation of the great tidal marshes along the Atlantic and Pacific coasts and the cleaning out of the channels of the larger rivers, canals, and harbors are being continually carried on by the Government. The most efficient and economical excavator for this class of work is the hydraulic or suction dredge.

**Construction.** The essential parts of a hydraulic dredge are a revolving cutter, a centrifugal pump, and the machinery to drive it, and the barge or hull. Detailed views of a hydraulic dredge are shown in Figs. 58 and 59.

The hull is usually rectangular in shape and has a length of about  $3\frac{1}{2}$  times its width. The size of the hull depends on the capacity of the dredge. The depth varies from 6 feet to 15 feet, providing a draft of from 3 feet to 9 feet. Hulls are constructed of wood or steel, but the latter material is the preferable on account of its greater strength, durability, and rigidity. Cross-frames of steel or wood are placed on about 2-foot centers and connect the keelsons and deck beams. This framework is covered with steel plates or heavy wooden planking. The winch machinery is placed on an upper deck while the pumping machinery is placed on a lower deck. A superstructure houses the machinery and contains the operating room and usually living quarters for the crew.

At the stern of the hull is located a vertical frame from which are suspended two spuds by means of sheaves and cables leading to the winch drums. The spuds are generally single timbers of fir, pine, or oak, and are of sufficient length to reach the bottom of the excavation at high water.

**Operating Equipment.** The operating equipment of a hydraulic dredge consists of the winch or hoisting engine and the pumping equipment.

The hoisting engine controls the movement of the barge, the operation of the ladder and of the spuds. It generally consists of 5 drums which are mounted on a single base and operated by a double-cylinder engine. Upon the forward shaft, the drums on each side swing the dredge and the center drum is used for the raising and lowering of the outer end of the ladder. The two rear drums operate the two spuds at the stern of the barge. In some cases a separate engine is used to operate the spuds.

The pumping machinery consists of a centrifugal pump and the engine to operate it. The pump is the most important element in the construction and operation of a hydraulic dredge. The excavated material is drawn up through the suction pipe and discharged through the discharge pipe to scows or to spoil banks on shore. The pump consists of a shell or casing of circular form with two apertures, one on the periphery and the other at the center of one side. Inside this shell revolves a set of vanes mounted on a shaft which extends through the center of the casing and is usually direct-connected to the engine. The vanes are generally made in two sections; the inner section, which is made as a part of the shaft; and the outer sections which are separate pieces bolted to the inner section. The abrasion by the material passing through the pump is largely on the outer sections of the vanes, which can be easily unbolted and replaced. The opening in the center of the side is the admission orifice to which the suction pipe is attached and through which the material enters the casing. The steel suction pipe is ordinarily from 15 to 30 inches in diameter and varies in length from 10 feet to 60 feet. To the periphery of the casing is attached the discharge pipe, which varies in diameter from 6 inches to 48 inches. A 20-inch centrifugal pump is shown in Fig. 60.

The pump is usually direct-connected to a steam engine of the vertical, marine type. For the small sizes and capacities, compound engines are used, but for large capacities, hard service, and high heads, triple-expansion engines are used.

**Excavating Equipment.** The excavating equipment of a hydraulic dredge consists of the gantry, ladder, and cutter. The excavating equipment of a small dredge is shown in Fig. 61.

The gantry is a double, inclined, timber frame which carries

the sheaves over which pass the cables for raising and lowering the outer end of the ladder.

The ladder is a steel-framed girder which is hinged to the bow of the hull at its inner end and suspended by cables at its outer end. On the upper side of the ladder is placed a gear-operated shaft which drives the cutter and the suction pipe.

The cutter is a series of knives which revolve about the hood or circular mouthpiece of the suction pipe. The type of cutter used depends upon the character of the material to be excavated; a heavy, chrome-steel head being used for hard materials and where

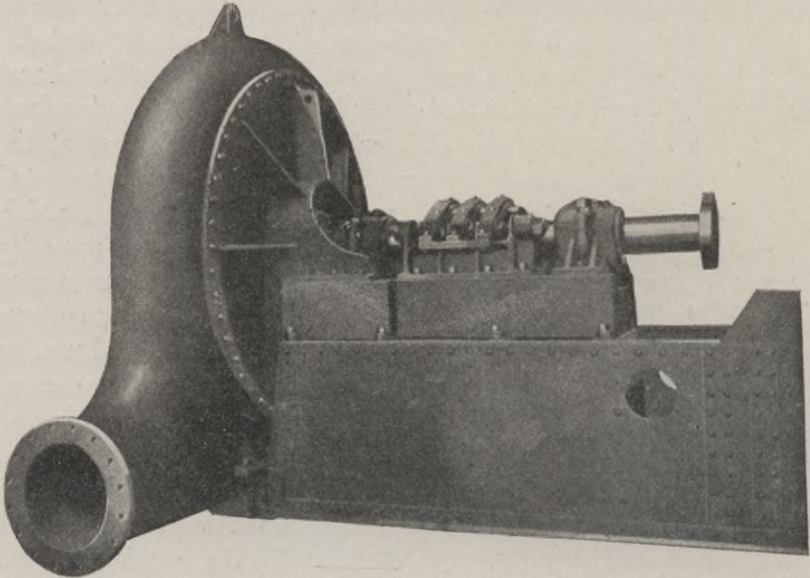

Fig. 60. Centrifugal Pump of Hydraulic Dredge

boulders are prevalent, while a light, open construction is used for soft materials and in places where brush and roots occur.

**Electric Power for Operation.** Dating from about 1910, the prevalence of cheap water power has led to the use of electric power for the operation of hydraulic dredges in several cases. The electrical equipment includes the wound-rotor type of motor to operate the cutter, the hoisting engine, the pump, and the spuds.

On isolated work, where fuel would be expensive on account of high transportation costs, but where water power is available, or in the proximity of large cities where electric power from large

steam plants is obtainable at low rates, it will be found more economical to carry a branch transmission line to the dredge and use an electrical equipment. The advantages of compactness, cleanliness, and efficiency, which have been previously discussed for the ladder dredge, are as applicable in this case.



Fig. 61. Typical Hydraulic Dredge on Canal Construction  
*Courtesy of Great Lakes Dredge and Dock Company, Chicago*

**Method of Operation.** The dredge is held in position by cables which extend from the main or hoisting engine to anchorages on either side of the bow, and by the two spuds in the stern of the hull. By alternately raising a spud and winding up and unwinding the cables, the dredge may be swung from side to side so as to cover a wide area.

The revolving cutter excavates the material, which may vary

from silt to hard pan. The disintegrated material, diluted by water, is sucked up through the suction pipe into the pump and then forced out through the discharge pipe which is carried by pontoons, and discharges into scows or out upon an area which is to be filled in.

**Cost of Operation.** It is impossible to give any accurate statement as to the average cost of excavation with a hydraulic dredge. Such a dredge on work of any magnitude is usually made especially for the particular conditions at hand and the cost of operation may vary within rather wide limits.

*Illustrative Example.* Following is a typical labor schedule for the operation during an 8-hour shift of a hydraulic dredge equipped with a 20-inch centrifugal pump.

#### Labor Expense Schedule

LABOR	MONTHLY RATE
1 operator	\$100.00
1 engineer	100.00
1 engineer	80.00
3 firemen, @ \$70.00 each	210.00
1 spudman	60.00
1 oiler	50.00
4 deck hands, @ \$50.00 each	200.00

The average cost of operation would depend upon the size and capacity of the dredge, the character of the material, efficiency of operation, kind of power used, etc. Records of recent work show a range of from 4 cents to 15 cents per cubic yard for materials varying from sand to indurated gravel.

**Field of Usefulness.** Hydraulic dredges have been in use for the last half century, but their greatest development has been during the last two decades, since 1895. In Europe their use has been largely in the maintenance of channels in the large rivers and in the construction of great canals. In this country they have been used principally in the reclamation of low, wet lands, along rivers, lakes, and harbors, the construction of great artificial waterways, such as the New York State Barge Canal and the Panama Canal, and the maintenance of channels in large inland waterways, such as the Mississippi River.

The earlier types of hydraulic dredge were provided with an agitator and water jets at the mouthpiece end of the suction pipe, and hence they could handle only the softer soils, such as silt, sand,

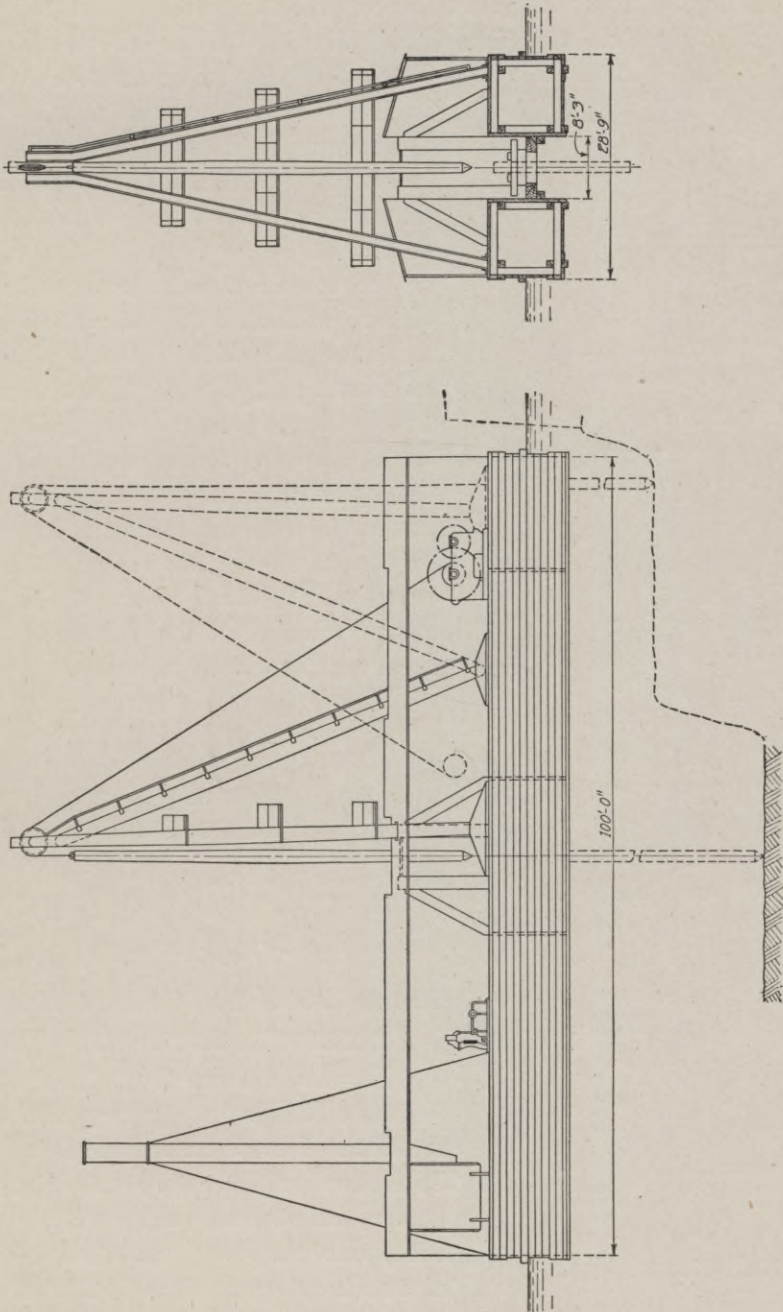

Fig. 62. Side Elevation and Cross-Section of Lobnitz Rock Cutter



and clay. In recent years, however, the cutter head has been developed in different forms, and very hard dense soils can be loosened and broken up sufficiently to be discharged through the pump.

The hydraulic dredge is not an economical type of machine to use in the construction of levees or in canal excavation where the disposition of the excavated material must be made within a confined space. The material as it emerges from the discharge pipe is [in such a [high state of dilution that it will not remain in place unless confined within banks or bulkheads. Some method of removing the surplus water in the discharge pipe may be used effectively; one such method being the installation of overflow strainers placed at intervals in the upper sections of the pipe.

This type of dredge is unique among excavators in its ability to discharge the excavated material in any direction and at a considerable distance from the site of the excavation. This wide range of disposal is of especial value in the filling in of waste lands along waterways.

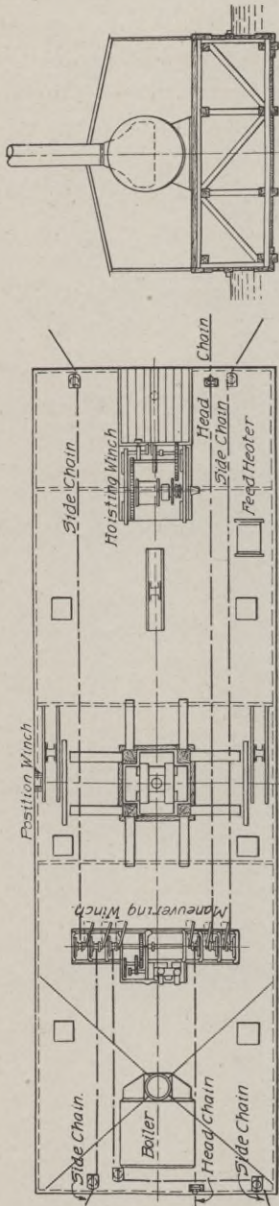

Fig. 63. Plan of Lobnitz Rock Cutter

**SUBAQUEOUS ROCK BREAKERS**

**LOBNITZ ROCK CUTTER**

For use in connection with the beds of channels through very indurated materials or rock which must be broken up before the removal by dredge, there are two radically different types of rock breakers: the Lobnitz rock cutter; and the drill boat.

The Lobnitz rock cutter consists of a heavy chisel of steel, weighing from 4 tons to 15 tons, and equipped with a hardened-steel cutting point. The chisel is raised to a height of from 5 to 10 feet and then dropped upon the surface of the hard material. The impact of the falling point serves to splinter and fracture the material so that it can be removed by the dipper of a floating dipper dredge, or by the buckets of a ladder dredge. The cutter is capable of breaking up the hardest rock, in layers 3 feet thick at a time. The cutter is mounted on a hull composed of two barges, rigidly connected by cross-frames. The details of a Lobnitz rock cutter are shown in Figs. 62 and 63.

In Europe, where this form of rock breaker is in general use, the ladder dredges are often provided with several picks or chisels, located in a well alongside of the ladder. These chisels are placed about 2 feet apart and are operated singly or in unison. The picks are generally made of heavy timbers which are provided with hardened-steel points. The buckets of the ladder dredge are made especially heavy and provided with teeth on the cutting edges. With a 10-pick ladder dredge, an excavation of 43 tons of hard rock per hour has been made.

#### THE DRILL BOAT

**Speed a Characteristic.** The Lobnitz rock cutter has not found favor in this country on account of its slow speed and cumbersome method of operation. Hence, a drill boat has been devised and this machine uses the standard steam-actuated percussion drills, which provide great lifting and striking power combined with a larger number of blows per minute.

The drill boat consists of a barge equipped with a spud at each corner to support it upon the bed of the stream during the drilling. Each of the four spuds is operated by a pair of independent engines geared to a rack on the side of the timber. When the drills are in operation, the spuds are forced down until the boat is raised above the height of normal flotation. The constant elevation of the boat is maintained by the automatic regulation of the steam pressure in the spud engines.

The drills are steam-operated percussion drills, similar in design and operation to the ordinary steam drills used in drilling

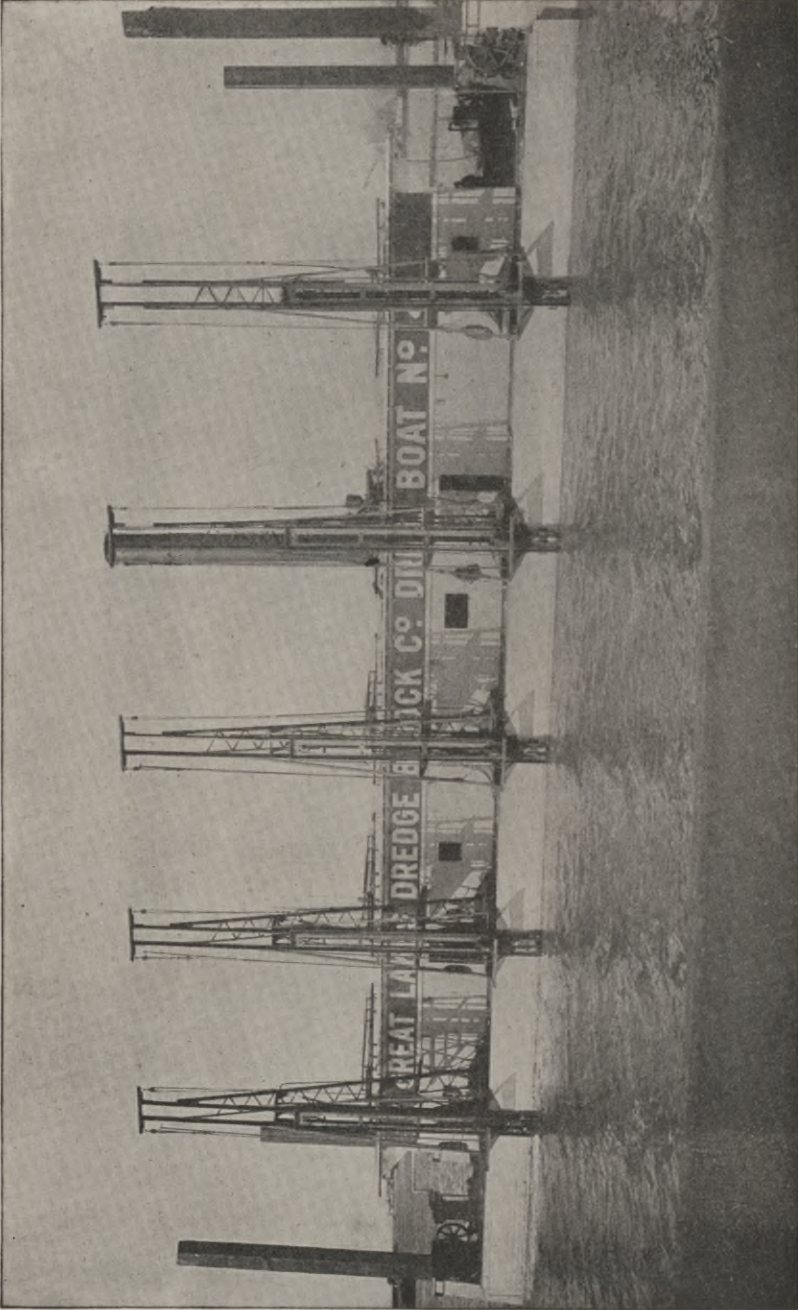

Fig. 64. Drill Boat Operating in a Harbor Channel  
Courtesy of Great Lakes Dredge and Dock Company, Chicago



**KOPPEL DUMP CARS AND BROWN HOIST HANDLING CRUSHED ROCK FOR CONCRETE ROADS**  
*Courtesy of Orenstein-Arthur-Koppel Company, Chicago*



on land. The piston diameter is from  $5\frac{1}{2}$  inches to  $6\frac{1}{2}$  inches, and the drills are mounted on movable steel towers, which run on a track along the side of the barge. The drills may be raised or lowered along vertical guides 15 feet to 30 feet in length. The feed of the drill is controlled by hydraulic plungers having a stroke equaling the length of the guides and moved by long screws which are operated by small engines. The towers are moved along the track by steam or by hydraulic power.

A view of the drill side of a drill boat drilling and blasting bed rock in Boston Harbor channel, is shown in Fig. 64.

**Cost of Operation.** The output and cost of operation of a drill boat depends upon the number and size of drills, the character of the rock, the depth of excavation, etc. It is impossible to state any general rules which may be used in this class of work. The following statement is given as a typical case of the use of a drill boat in channel excavation.

*Illustrative Example.* The work consisted in the excavation of a ship channel, 200 feet wide and 17 feet deep, in a large river. The material was a very hard limestone rock occurring in strata from 20 inches to 30 inches thick. The work was carried on in a stream having a current of from 8 miles to 12 miles an hour, in an area of turbulent water.

The drill boat was equipped with four 5-inch drills, which operated through four slots, each 20 feet long and 18 inches wide, and located in the forward part of the barge. The drill frames carried steel drill spuds with pipe guides for the drill bars, and were arranged to move along tracks the length of the wells. Thus each drill made several holes at each set-up of the barge. Holes were drilled and blasted in groups of four. The rock was drilled below grade to a depth equal to half the hole spacing, which was about 6 feet. The dynamite used was proportioned on a basis of about 1 pound to a cubic yard of rock.

The barge was supported on four 20×20-inch power-controlled spuds. Gear drums operated five  $1\frac{1}{4}$ -inch breasting chains, one leading upstream, and two over each side. Each chain was attached to an anchor weighing about 1 ton.

The monthly cost of operation is as follows:

## Operating Cost of Drill Boat

*Labor:*

1 captain	\$100.00	
4 drillers, @ \$75.00 each	300.00	
4 helpers, @ \$30.00 each	120.00	
1 fireman	30.00	
1 machinist	65.00	
1 blacksmith	70.00	
1 helper	30.00	
1 blaster	60.00	
1 helper	35.00	
1 cook	30.00	
	<hr/>	
Total labor expense, per month		\$840.00

*Board and Lodging:*

16 men, @ \$12.00 each, per month	\$192.00
-----------------------------------	----------

*Fuel and Supplies:*

60 tons coal, @ \$4.00	\$240.00	
Oil, and waste	40.00	
Blacksmith's coal	15.00	
Steel, iron, and supplies	52.00	
	<hr/>	
Total fuel and supplies		\$347.00

Grand total, per month		\$1,379.00
Cost of Drilling, per drill hour		1.105
Cost of Drilling, per foot drilled		0.049
Average Depth of Drilling, per hour (ft.)	2½	
Depth of Drilling (ft.)	0 to 11	

**Field of Usefulness.** The two types of rock breakers are very efficient for subaqueous rock drilling and give results which compare favorably with drilling on land.

The Lobnitz rock cutter works most efficiently in shallow cuttings of stratified rock, which is easily shattered. The drill boat, of the American type, does its most efficient work in hard rock of depths of over 3 feet.

## TRENCH EXCAVATORS

**Classification.** The great amount of trenching necessitated by the construction of sewer, water-supply, and drainage systems has led, in recent years, to the development and use of excavators especially adapted to this class of work. These trench machines are more efficient and economical than hand labor on work of any magnitude.

Trench excavators may be divided into two general classes as follows:

- (1) Sewer and water-pipe trench excavators.
- (2) Drainage-tile trench excavators.

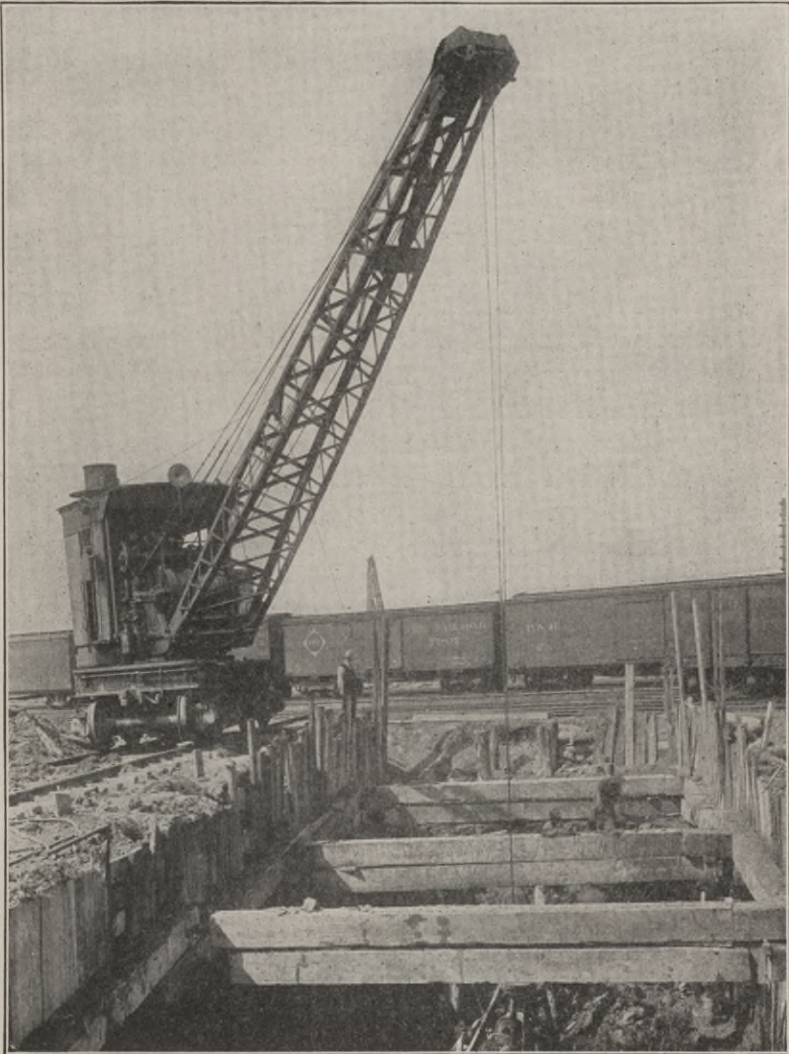

Fig. 65. Traveling Derrick on Trench Excavation Work  
*Courtesy of Brown Hoisting Machinery Company, Cleveland, Ohio*



## PIPE-TRENCH TYPES

This class of excavators embraces five distinct types as follows: the traveling derrick or locomotive crane, the continuous bucket excavator, the trestle-cable excavator, the trestle-track excavator, and the tower cableway.

## TRAVELING DERRICK

The traveling derrick or locomotive crane is a very useful and adaptable type of excavating, hoisting, and conveying machine. It has been serviceable in many lines of construction work as the machine may be used for excavation, transportation of various kinds of materials, loading and unloading wagons, cars, barges, etc. In this discussion, we will consider the machine only as a trench excavator.

**Construction.** The essential parts of a traveling derrick are the car, the hoisting engine, and the derrick. The machines are made in capacities varying from 3 tons to 20 tons. A machine on trench excavation is shown in Fig. 65.

The car is a steel-frame platform which supports directly the cast-iron turntable bed and the counterweights. The platform is mounted on a 4-wheel truck, equipped either with broad-tired wheels for road traction, or with standard railroad wheels for the smaller sizes of crane. The larger sizes, generally above 10-ton capacity, are mounted on two 4-wheel trucks, equipped with standard railroad wheels. The car is provided with drawbars for the 4-wheel type, and couplers, steam brake, grab handles, steps, etc., for the 8-wheel type.

**Operating Equipment.** The power for the cranes may be steam, electric, or that furnished by an internal-combustion engine. Ordinarily steam power is used, but the other kinds would be more economical when the cost of coal or wood is high compared with electric power and gasoline.

The steam equipment consists of a boiler, engine, hoisting mechanism, rotating mechanism, and traveling mechanism. The boiler is of the vertical, tubular type, and should be capable of working at a pressure of 100 pounds with quick-steaming qualities and large steam capacity. The engine is usually of the vertical, double-cylinder type, provided with link-motion reversing gear, wide-

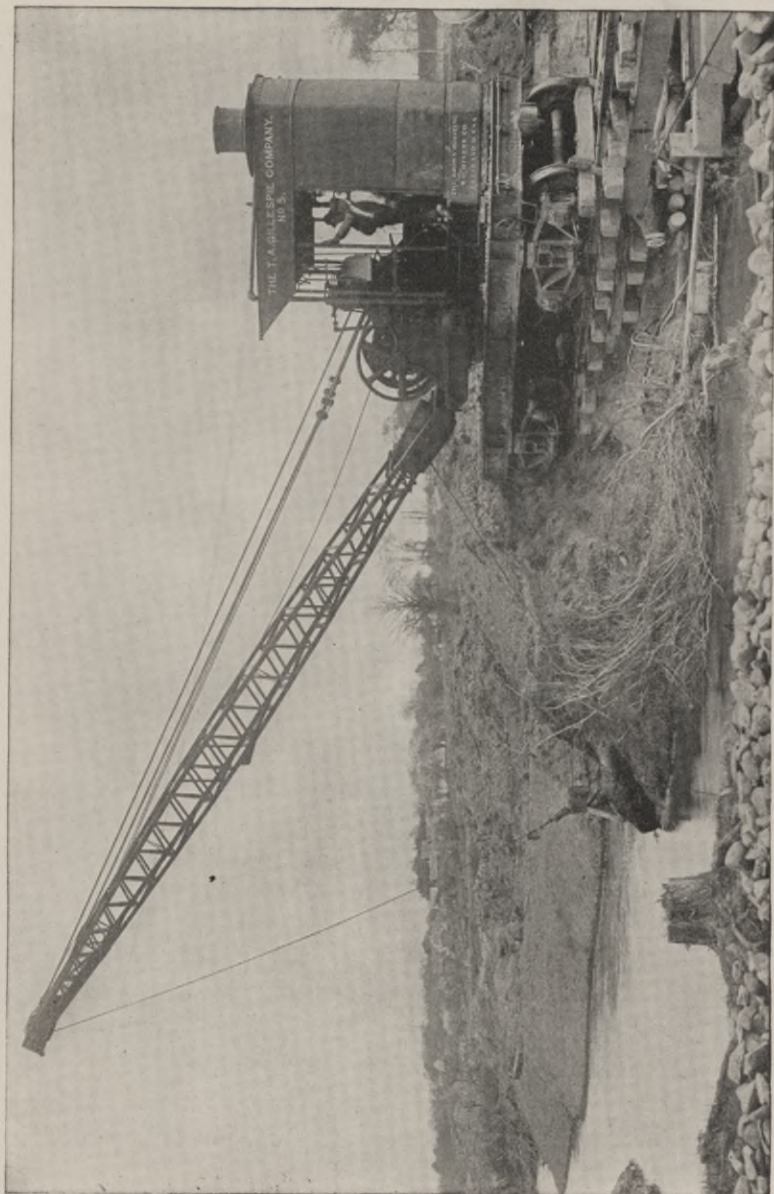

Fig. 66. Traveling Derrick on Canal Construction  
Courtesy of Brown Hoisting Machinery Company, Cleveland, Ohio

ported slide valves, etc. The hoisting mechanism consists of a double-drum winch. The hoist drum is driven from a friction clutch on the main engine shaft. The shell drum is operated from the hoist drum by a slip friction. Both drums are controlled by friction-clutch brakes, lever-operated by one man. The rotating mechanism consists of 2 friction clutches driving a chain of gears. The upper platform, which supports the operating and excavating equipments, can be revolved in either direction through a complete circle. The traveling mechanism consists of a set of gears driven by a friction clutch on a shaft geared to the crank shaft of the engine. The machine may be moved in either direction.

**Excavating Equipment.** The excavating equipment consists of the boom or crane, and the dipper or bucket. The boom is a steel-frame structure, hinged at its lower end to the front of the upper platform, and supported at its outer and upper end by guys extending to the rear corners of the platform. At the outer end of the crane is the sheave over which the hoist line passes on its path from the drum to the bucket.

The bucket or dipper may be a grab bucket, of the orange-peel or clam-shell type, or a drag-line dipper. The former is used for the excavation of softer soils while the latter is more serviceable in the removal of the denser and harder soils. In the latter case, a separate drag-line drum must be provided in the hoisting mechanism. A traveling derrick using a drag-line bucket in canal construction is shown in Fig. 66.

**Method of Operation.** A traveling derrick is operated by a crew of three to ten men, depending on the amount of extra labor necessary. An engineer controls all the operations of excavating, rotating, and traveling, a fireman operates the boiler, a signalman is often necessary for deep-trench work, and one or more laborers are used for general service about the machine and in the excavation. When a skip is used, shovelers are required.

The method of operation is very similar to that of a revolving shovel and the student is referred to that section of the text for a complete discussion of this subject.

On trench excavation, one machine may be used for excavation only, or may excavate and later return to back fill. On large works, it has been found advantageous to use two or more machines

coordinately; one for the rough excavation, one for the finished excavation and for handling pipe and materials, and one for the back filling.

**Cost of Operation.** The cost of operation would vary greatly with the size of the machine, the efficiency of its operation, the character of the material, etc. The following statement is given as an approximate idea of the cost of operation under average conditions.

*Illustrative Example.* A 10-ton machine, equipped with an automatic clam-shell bucket of 1-yard capacity, and moving on a track along the side of the trench, will be considered. The material is clay for a depth of 8 feet, and is underlaid by a substratum of gravel. Following is an estimate of the cost of operation for a 10-hour working day:

<b>Operating Cost of Traveling Derrick</b>		
<i>Labor:</i>		
1 engineer	\$5.00	
1 fireman	2.50	
3 laborers, @ \$2.00 each	6.00	
Total labor cost, per day		\$13.50
<i>Fuel and Supplies:</i>		
1 ton coal	\$4.00	
Oil, waste, and repairs	1.50	
Total fuel and supplies		\$5.50
<i>General and Overhead Expenses:</i>		
Depreciation (5% of \$5000)*	\$1.25	
Interest (6% of \$5000)*	1.50	
Incidental expenses	2.25	
Total general expense		\$5.00
Total Cost of Work for 10-hour Day		\$24.00
Total Excavation for 10-hour Day (cu. yd.)	400	
Unit Cost of Traveling Derrick Excavation, per cu. yd.,		
\$24.00 ÷ 400 =		00.06

**Field of Usefulness.** The traveling derrick is economical for trench excavation when the soil is loam, clay, sand, or gravel, and can be easily handled by a grab bucket, or a drag or scoop bucket. This type is especially adapted for wide trenches, over 5 feet in width, which cannot be readily excavated by other types.

\*Based upon 200 working days in a year and a 20-year life.

This type of excavator is very efficient with good management, as it may be used for excavation, back filling, and pulling sheeting.

### CONTINUOUS BUCKET EXCAVATOR

**Construction.** There are several makes of machine, which are especially devised for the digging of trenches with vertical sides. This type of excavator has been developed in recent years to meet the demand for a machine for municipal work under favorable conditions of soil and for large work.

An analysis of continuous bucket excavators shows the following essential parts: a frame supported on wheel trucks, the operating

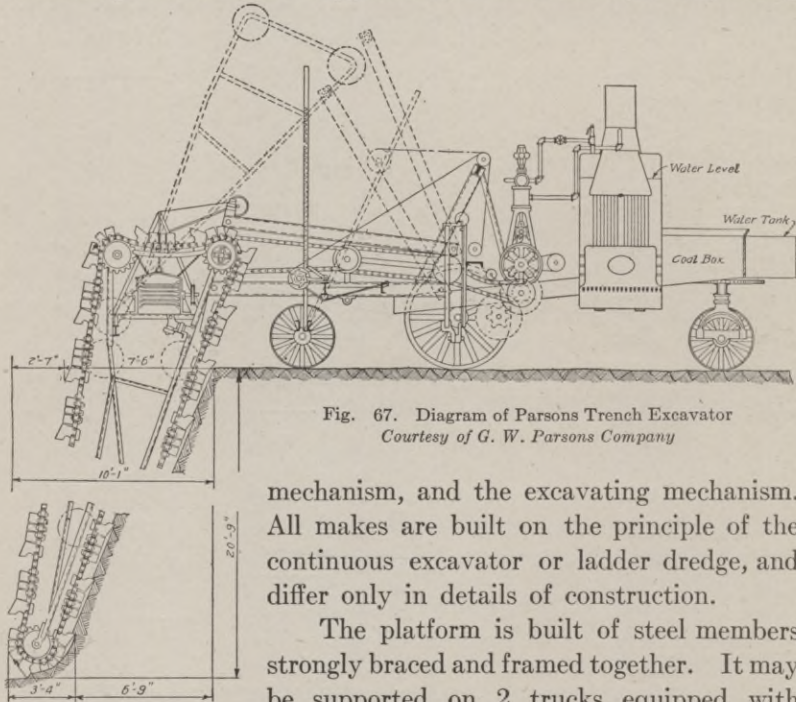

Fig. 67. Diagram of Parsons Trench Excavator  
Courtesy of G. W. Parsons Company

mechanism, and the excavating mechanism. All makes are built on the principle of the continuous excavator or ladder dredge, and differ only in details of construction.

The platform is built of steel members strongly braced and framed together. It may be supported on 2 trucks equipped with broad-tired wheels, or made in two sections and supported on 3 trucks. In the latter case, the rear section which carries the excavating chain is hinged to the main section and is supported on 1 truck. Fig. 67 shows a diagrammatic view of this type, and Fig. 68 shows a view of the single-platform machine.

**Operating Equipment.** A steam or internal-combustion engine may be used. The latter is more economical in sections of the

West where coal is expensive, and is cleaner, more compact, and does away with the use of a fireman and the discomfort of a boiler in warm weather.

A steam-power equipment consists of a boiler, an engine, and the transmission mechanism. The boiler is of the vertical, tubular type and is placed near the front end of the platform. The engine is placed behind the boiler and is of the single-cylinder, vertical type. Power is transmitted to the bucket chain, the disposal conveyor, and the central axle, for traction through gears and sprocket chains.

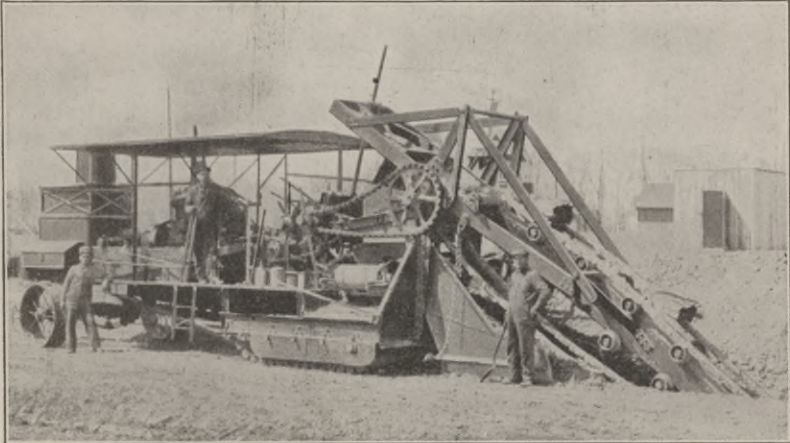

Fig. 68. Chicago Trench Excavator  
 Courtesy of F. C. Austin Drainage Excavator Company, Chicago

**Excavating Equipment.** The excavating equipment consists of the bucket chain, and the disposal conveyor. The bucket chain in one type of machine comprises an endless chain moving over sprocket wheels on the ends of an arm, which is suspended from the rear end of the platform and is adjusted to permit of the excavation to the proper grade regardless of inequalities of the surface over which the machine passes. In the other type of trench machine, a circular wheel is suspended from the rear of the platform and revolves on a central axle.

The buckets are attached to the sprocket chain or to the periphery of the wheel. They are scoop-shaped and provided with cutting edges or teeth, depending upon the nature of the material to be excavated. The width of the trench is governed by the

width of the buckets, which are made in several widths and can be easily removed and changed. In one make of machine, an increased width of trench can be secured by moving the whole bucket chain sideways along the supporting frame. This arrangement provides for the excavation of a trench up to 6 feet in width without changing the buckets and also the excavation of a manhole at any point without delay. Fig. 69 shows a sectional bucket used on the Parsons Trench Excavator.

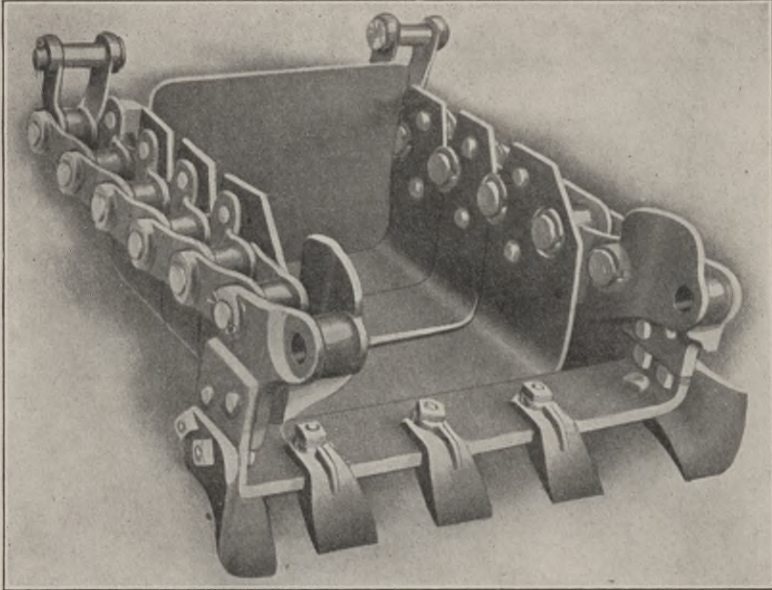

Fig. 69. Sectional Buckets Used on Parsons Trench Excavator

The disposal conveyor consists of a belt conveyor placed at the rear of and transversely to the platform. Its elevation is below the top of the bucket chain. At the top sprocket, the buckets turn over and deposit the material on this moving belt, which conveys it to one side of the trench and deposits it in a spoil bank.

**Method of Operation.** The labor crew necessary to operate a trench excavator depends on the character and magnitude of the work and the kind of power used. With a steam-power equipment, an engineer or operator, a fireman, and one or more helpers

TABLE VI  
Sizes and Capacities

AUSTIN TRENCH EXCAVATORS										
Size No.	Power, Kind	Weight (tons)	EXCAVATION		Digging Speed Maximum (ft. per min)	TRACTION BEARING		DIMENSIONS OVER ALL		
			Depth Maximum (ft.)	Width (in.)		Sizes Each (in. X in.)	Area Total (sq. ft.)	Width (ft.)	Length (ft.)	Wheel Base (ft.)
000	Gasoline	9.	6	12, 15, 18	10	24 X 60	20	8	33	12½
00	Gasoline or Steam	11.3	8	15, 18, 24	9	30 X 60	25	9	36	13
0	Gasoline or Steam	20.	10	18, 24, 30, 36	10	30 X 72	30	10	45	16
1	Gasoline or Steam	24-25	15	24 to 36	6	30 X 108	45	10	44	16
10	Steam	33.	20	24 to 72	3	28½ X 132	52¼	10	57	21½

PARSONS TRENCH EXCAVATORS										
Type	Power	Weight (tons)	EXCAVATION		BUCKETS		Wheels (no.)	Traction Kind	DIMENSIONS OVER ALL	
			Depth (ft.)	Width (in.)	Length (in.)	Width (in.)			Depth (in.)	Width (ft.)
KO	Gasoline or Steam	11	8	22	24	22	2	Caterpillar	9½	42
K	Gasoline or Steam	14	12	22 to 42	24	22	2	Caterpillar	9½	46
E	Gasoline or Steam	24	20	28 to 60	28	28	6	Wheel or Caterpillar	10	35
F	Steam	26	20	28 to 78	28	28	6	Wheel or Caterpillar	10	35

BUCKEYE TRACTION DITCHERS									
Type	Power	Weight (tons)	EXCAVATION		Wheel Base (ft.)	Tread Front Wheels (ft.)	Width Rear Tires (in.)	Cost	
			Depth (ft.)	Width (in.)				Wheel	Caterpillar
5	Gasoline or Steam	15	5½	20, 24, 28	14½	8½	20	\$4200	\$4700
6	Gasoline or Steam	16	6½	20, 24, 28	14½	8½	20	4500	5000
7	Gasoline or Steam	17½	7½	20, 24, 28	17½	7½	20	4700	5200
8	Gasoline or Steam	21	7½	24, 28, 32, 36	17	8½	24	5500	6000
9	Gasoline or Steam	33	10	28, 36	20	8½	28	7300	7900
10	Gasoline or Steam	38	12	28, 36	22	8½	30	8000	8750



will be required. The operator has direct charge of the operations of excavation and traction. The fireman operates the boiler and has general supervision of the engine. The helpers are of general service in furnishing the machine with fuel, water, and supplies, in bracing the trench when necessary, and in general service about the work.

The bucket chain moves downward and inward and removes a thin slice of material as each bucket comes in contact with the soil. The depth of cut is regulated by raising and lowering the free end of the frame. When obstructions, such as cross pipes, large boulders, etc., occur, the chain may be raised over them and fed down into the earth on the other side. The material, from the top of the revolving chain or wheel, falls upon the belt conveyor and is carried to either side of the trench, making a continuous spoil bank.

When one section has been excavated, the machine moves ahead and starts another slice. The excavating chain or wheel can be raised clear of the surface and the machine moved over ordinary roads at a speed of about 1 mile per hour. Table VI gives the dimensions, weights, capacities, and costs of three different makes of trench excavator.

**Cost of Operation.** The following comparison of the cost of excavation of a trench by hand and by machine labor will be of interest to the student, who is urged to make a close study of the method of analysis.

*Illustrative Example.* The soil is clay and loam and the ground surface fairly level and solid enough to support a trench machine. The trench has a width of 28 inches and an average depth of 12 feet. Each laborer will excavate 7 cubic yards per 10-hour day and as the material must be rehandled for the last 3 feet of depth of cut, we will assume 5 extra men for the work and not include their output. A crew of 45 men will dig 350 feet of trench during a 10-hour day and the total excavation will be about 315 cubic yards. The same crew will back fill at a cost of 7 cents per cubic yard. The machine will excavate 250 feet of trench per 10-hour day. The back filling will be done by teams and scrapers.

Following is a detailed statement of the cost of the work for the two methods, based on a 10-hour day.

**Cost of Trench Excavation by Hand**

*Labor:*

1 foreman	\$ 4.00	
1 timberman	3.00	
1 helper	2.50	
1 pipe layer	3.00	
1 helper	2.50	
50 laborers, @ \$2.00 each	100.00	
	<hr/>	
Total labor cost for excavation		\$115.00
Back filling 315 cubic yards, @ 7c		22.00
		<hr/>
Total cost of Hand Work for a 10-hour Day		\$137.00

**Cost of Trench Excavation by Machine**

*Labor:*

1 foreman	\$ 4.00	
1 timberman	3.00	
1 helper	2.50	
1 pipe layer	3.00	
1 helper	2.50	
1 engineer	4.00	
1 fireman	2.50	
3 teams, @ \$4.00 each	12.00	{ 1 hauling for excavator 2 back filling trench
2 laborers, @ \$2.00 each	4.00	
	<hr/>	
Total labor cost, per day		\$37.50

*Fuel and Supplies:*

1 ton coal	\$5.00	
Oil, and waste	1.00	
Water	1.00	
	<hr/>	
Total fuel and supplies		\$7.00

*Overhead and General Expenses:*

Interest (6% of \$6000)*	\$1.80	
Depreciation (10% of \$6000)*	3.00	
Repairs	2.70	
Incidentals	4.50	
	<hr/>	
Total general and overhead expenses		\$12.00

Total Cost of Operation for a 10-hour Day \$56.50

Total cost of excavation of 315 feet of trench, pipe laying, and back filling by hand work, for a 10-hour day, is \$137.00.

Total cost of excavation by machine of 225 feet of trench, pipe laying by hand work, and back filling by scrapers is \$56.50.

\*Based upon 200 working days in a year and a 10-year life.

A comparison of the above results shows that during a 10-hour day, a trench excavator will do about 70 per cent of the amount of trench excavation that can be done by hand labor and at 40 per cent of the cost.

**Field of Usefulness.** The continuous bucket excavator is especially adapted for trench excavation, where the width does not exceed 72 inches and the depth 20 feet, and the soil conditions are favorable. This is especially true through the Middle West, where clay and loam with few obstructions such as boulders, roots, etc., predominate up to shallow depths.

On account of the great weight of the machines, they are not practicable for use in soft, wet soils, unless mounted on caterpillar tractors. For the excavation of hard soils, considerable trouble is often experienced on account of the breaking of the bucket chain. Hence it is desirable to use a machine with a strong, heavy chain for the digging of hardpan, blue clay, and other hard, tough materials.

The trench excavator is efficient and economical for the excavation of trenches 24 inches and over in width and over 6 feet in depth, and one machine can do the work of from 80 to 200 men.

#### TRESTLE CABLE EXCAVATOR

**Construction.** The trestle cable excavator has been in general use, especially in the eastern section of this country, during the past 30 years, for the excavation and back filling of large trenches for waterworks and sewer systems. It has many admirable features and is especially well-adapted to large sewer trench work in hard soils. A trestle cable excavator on sewer-trench construction is shown in Fig. 70.

This type of excavating machine consists of a series of trestles supporting an overhead track. The trestles or bents are connected by rods at the bottom and by the beam track at the top and rest upon a plank or rail track. The operating machinery is carried by a platform located at one end of the structure. The overhead track supports several carriers which carry the buckets or tubs. The whole framework is self-contained and can be moved ahead as a unit from one section of the work to another.

The trestles are made of timber framed together to form square or A-shaped bents. They are from 15 feet to 20 feet in height

and are equipped with castor frames, wheels, etc. These bents are connected together at the bottom by bars of tubular steel of from 1 inch to  $2\frac{1}{2}$  inches in diameter. The bents rest on T-rails which are spiked to sections of planking, and enough track is provided to move the whole machine ahead 100 feet at a time.

The track or support for the travelers or carriers is made up of sections of I-beams or channels which are bolted to or hung from the head blocks of the bents.

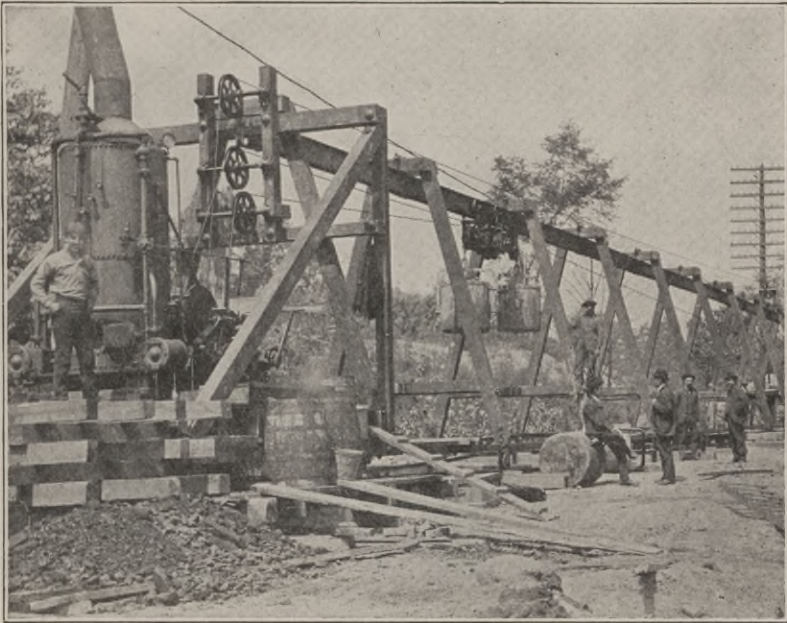

Fig. 70. Trestle Cable Excavator on Sewer Trench Construction  
*Courtesy of Carson Trench Machine Company, Boston, Massachusetts*

**Operating Equipment.** The operating equipment consists of the boiler, engine, and car upon which the machinery is placed.

The boiler is of the vertical, tubular type, and is equipped with all appliances for efficient operation and control. It is usually operated at a steam pressure of about 100 pounds. The engine is a 2-drum, double-cylinder, hoisting machine with reversible link motion. The drums are controlled by friction-clutch brakes; one carries the hoisting rope, and the other carries the endless rope which

operates the carriers and buckets. The drums are independent, and so arranged that they may be operated in unison or separately. The boiler and engine are generally mounted on the same bed plate which is supported by a platform mounted on rollers or wheel trucks. The front end of the car supports the head trestle. A suitable house is usually built, in sections, over the platform and may be used completely or partly, depending on climatic conditions.

**Excavating Equipment.** The excavating equipment consists of the tubs, the carriers, and the cables.

Upon the overhead track run several carriages, travelers, or carriers, which are provided with wheels made to fit the flanges of the structural sections. From each carrier is suspended a tub which is equipped with an automatic catch and is self-dumping and self-righting. The carriers are connected by a continuous rope which is operated by a drum on the engine, and are raised and lowered by hoisting ropes controlled by a rope operated by another drum on the engine.

**Method of Operation.** The labor crew necessary to operate a trestle cable excavator consists of an engineer, a fireman, a latchman, and a tubman. The engineer operates the engine and has general charge of the work. The fireman supplies the boiler with fuel, and oils the machinery. The latchman operates the latches, which release and grip the tub lines for raising and lowering the buckets. The tubman hooks and unhooks the tubs, and has general charge of their filling and emptying.

The machine being set up in position, the engineer operates the hoisting line and releases the jaw clutches on the tub ropes, thus allowing the tubs or buckets to drop into the excavation. The tubs are unhooked and another set of filled tubs hooked on. The loaded tubs are then hoisted up to the locks on the carriers, and the whole set is moved to the disposal place by the operation of the continuous traversing line. Usually one section of the trench is being excavated while another section is being back filled, so that the material removed at the former place can be utilized directly in the latter. It may be necessary at the beginning of the work, or in special cases of crossings, etc., to dump the material into temporary spoil banks, or into carts for removal from the site. As soon as one section is completed, the machine pulls itself ahead





AUSTIN TRENCHING MACHINE WITH CATERPILLAR DRIVE TRAVELING OVER SWAMP  
*Courtesy of Municipal Engineering and Contracting Company, Chicago*

by means of a winch on the engine and a rope passing through a snatch block attached to a deadman set ahead.

Machines may be had with double and single upper tracks. The nominal capacity of a double-track machine is 50 per cent greater than that of a single-track machine, as one set of buckets is being raised loaded, while the other set is being lowered empty. Thus 3 sets of buckets are continually in use, one set being filled, one hoisted and carried to the dump, and the other dumped and returned to be loaded. A double-track machine is more economical for trenches over 5 feet in width.

The average output for a 6-bucket, single-track machine is about 125 cubic yards for a 10-hour day.

**Cost of Operation.** The rental charge of a 6-bucket, single-track machine is about \$200 per month. The cost of transportation, setting up, and dismantling will vary with the distance, length of haul, experience of men, etc., and will range from \$100 to \$500.

About  $\frac{1}{4}$  ton of coal per day will be used, and the cost of oil, waste, supplies, etc., will vary from \$1 to \$5 per day. The net cost of operation of the machine would be about \$25 per day. Assuming an average output of 100 cubic yards, the cost of the work exclusive of sheeting, pumping, loosening of material in trench, etc., would be about 25 cents per cubic yard.

**Field of Usefulness.** The trestle cable excavator is especially adapted to the excavation of trenches for large sewers and water mains in hard soils, and in city streets. The work is restricted to the immediate area of the trench, leaving part of the street unobstructed for traffic. The method of operation is efficient, as the excavated material is generally used directly in back filling. The method of operation is also easy, simple, and safe.

#### TRESTLE TRACK EXCAVATOR

**Construction.** The trestle track excavator is very similar in its method of operation to the trestle cable excavator. The principal difference is the suspension of the carriers from a car or carriage which moves along a track supported on the tops of the trestles.

The construction consists of a series of light, steel-frame trestles, of trapezoidal shape and 6 feet in height, spaced about 10 feet on centers. These trestles are mounted on double-flanged wheels, which



run on rails. The tops of the trestles are connected by steel channels which form a continuous track on which the carriage runs.

**Operating Equipment.** The operating equipment consists of a vertical, tubular boiler, and a double-drum hoisting engine, carried on a car at the forward end of the machine.

**Excavating Equipment.** The excavating equipment consists of a steel-frame car supported on four wheels which run upon the trestle

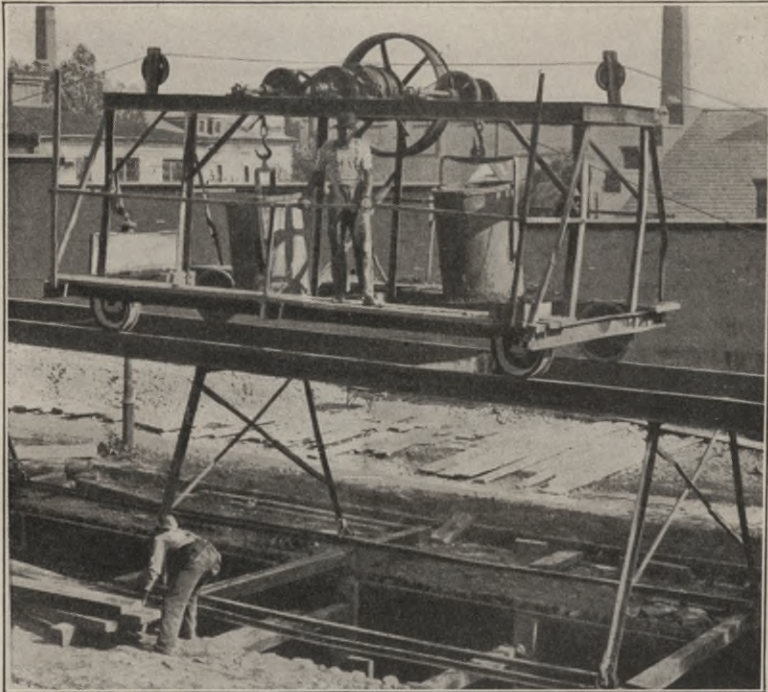

Fig. 71. Trestle Track Excavator  
*Courtesy of Potter Manufacturing Company*

track. The car is operated by cables which connect to the hoisting engine. On the car is a hoist which raises and lowers two steel buckets. The buckets are made in three sizes:  $\frac{1}{3}$ -,  $\frac{2}{3}$ -, and 1-cubic yard capacities. A view of a car in operation is shown in Fig. 71.

**Method of Operation.** The machine requires a crew of 3 men; one to operate the hoisting engine, and two to operate the bucket hoists on the carriage.

The carriage is moved by a cable from the hoisting engine to the place of excavation, where either one or both buckets are lowered into the trench, filled by the laborers in the trench, and raised above the floor of the car. The car is then moved to the place of back fill or dump, where the buckets are lowered and dumped.

**Cost of Operation.** The following statement is given as a typical case of the cost of excavation with a trestle track machine.

*Illustrative Example.* The trench had a width of 21 feet and an average depth of 30 feet. The material excavated consisted of a shallow top layer of loam, then 15 feet of soft blue clay, 6 to 8 feet of stiff blue clay, 1 foot of sandy loam, and then about 2 feet of hard blue clay. The trench machine was equipped with 6 buckets of  $\frac{1}{2}$ -cubic yard capacity, and 4 were filled while the remaining 2 were being removed and dumped. The excavator removed the lower 12 or 14 feet of the trench.

The following gives the cost of operation based on an 8-hour day.

#### Operating Cost of Trestle Track Excavator

*Labor:*

1 foreman	\$ 4.00	
1 engineer	5.00	
1 fireman	2.50	
1 car operator	3.50	
1 car helper	2.00	
20 laborers in trench, @ \$2.00 each	40.00	
1 laborer on dump	2.00	
Total labor cost, per day		\$59.00

*Fuel and Supplies:*

$\frac{1}{2}$ ton coal, @ \$5.00	\$2.50	
Oil, waste, etc.	1.00	
Repairs	1.50	
Total fuel and supplies		\$5.00

*General:*

Rent of machine, @ \$125 per month	\$5.00	
Total Cost of Operation for an 8-hour Day		\$69.00
Average Daily Excavation (cu. yd.)	175	
Unit Cost of Trestle Track Excavating, per cu. yd.,		
$\$69.00 \div 175 =$		00.39

**Field of Usefulness.** The trestle track excavator has the same scope and advantages as the trestle cable excavator. It is especially efficient in trench excavation in congested city streets where the

demands of keeping at least part of the street open to public traffic requires the restriction of the work to as limited an area as possible.

On very wide trenches, it is advisable to use a machine equipped with a double track and 2 cars in order to facilitate the work.

#### TOWER CABLEWAY

**Development.** The tower cableway is an excavating, hoisting, and conveying device devised about 1875 for slate quarries in eastern Pennsylvania. Then for a period of years the cableway was used largely in quarry work and logging operations. In more recent times, this machine has been adapted to the conveying of materials on construction work, the excavation of the lighter and softer soils, the hoisting and conveying of the harder soils excavated by other machinery, etc. This article will deal with the use of the cableway in trench construction only. A double cableway on trench excavation is shown in Fig. 72.

**Construction.** The essential parts of a tower cableway are the towers, the cable, bucket or dipper, carrier, and the power equipment.

The towers are framed timber structures varying in height with the location and character of the work. They are either fixed or anchored in position, or mounted on wheel trucks which run on tracks, thus providing for the movement of one or both ends of the cableway. The tops of the towers are provided with saddles and sheaves for the cables.

**Operating Equipment.** The operating equipment of a tower cableway consists of a boiler and an engine.

The boiler is generally of the vertical, tubular type, and equipped with the necessary accessories for operation at a pressure of 100 pounds.

The engine is a 2-drum, double-cylinder machine, fitted with reversible link motion. The drums are of the friction-brake type; one for the hoisting rope, and the other for the endless, traversing rope or cable. The drums are so arranged as to be operated together or independently. The machinery is placed on a housed-in platform built of timber and supported on 4 car wheels which run on short sections of the track.

**Excavating Equipment.** The excavating equipment comprises a traveler, the tubs, buckets or skips, and the cables.

The main cable is made of crucible steel and of a diameter depending upon the span, load, elevation, etc. It passes over



Fig. 72. Double Cableway on Trench Excavation  
Courtesy of S. Flory Manufacturing Company, Bangor, Pennsylvania

the tops of the towers, is anchored behind them, and is the track over which the carrier passes. The hoisting and traversing ropes

are crucible-steel cables of from  $\frac{5}{8}$  inch to  $\frac{7}{8}$  inch in diameter and extend from their respective drums on the engine over the sheaves at the tops of the towers and thence to the carrier.

The traveler or carrier is a wrought-iron frame which carries the sheaves over which pass the hoisting and traversing cables and the fall block which supports the tub, skip, or bucket. The carrier is provided with 2 or more flanged wheels which run on the main cable. One or more carriers may be used on the same cableway.

The fall block of the carrier supports the tub or skip which is of steel or wood and of widely varying capacity. For trench work tubs are generally used and are made of steel and provided with double bottoms and automatic catches. When the cableway is used for direct excavation, grab buckets or drag-line buckets are used and require special operating equipment.

**Method of Operation.** For trench excavation, a cableway having a length or span of from 200 feet to 400 feet is generally used. The length of excavation will be about 50 feet shorter than the distance between towers.

The labor crew required consists of an engineer, a fireman, a signalman and two or more laborers. The engineer operates the engine and has general charge of the work. The fireman provides the boiler with fuel and water, and looks after the oiling of the machinery. The signalman signals to the engineer for the raising and lowering of the bucket or tub. The laborers are used in filling and in dumping the tub, and in general service about the job.

The bucket is lowered into the trench, filled by the shovelers, and then raised above the excavation by the operating of the hoisting drum, which is thrown out of gear and held by a brake. The traversing line is then operated and the carrier moved in either direction until the bucket is over the place for dumping. Then the bucket is lowered by means of the brake band on the hoisting drum. The material may be used for back fill in a section of trench where the pipe is laid or dumped into a spoil bank or into wagons for removal to a distant place of disposal. A small crane or derrick may be used to advantage, adjacent to the excavation, for the transfer of the buckets from the cableway to the dumping board or hopper.

**Cost of Operation.** A typical case of sewer trench construction will be considered in the following statement of the cost of excavation with a cableway.

*Illustrative Example.* The trench is 12 feet wide and with an average depth of 20 feet. The soil varies from a surface layer of loam of 2-foot depth, through a clay substratum of 8 feet, to a hard gravel deposit. The machine has two 30-foot towers placed 300 feet apart and is equipped with 1-yard tubs or buckets. Bracing and sheeting were carried on at the same time as the excavation, and the sewer construction followed closely to allow for back filling at one end of the section with the material from the other end.

Following is an estimate of the cost of excavation under average working conditions, during a 10-hour day. A crew of 30 men are required to pick and shovel the material into the buckets and the average daily output will be taken as 300 cubic yards.

<b>Operating Cost of Tower Cableway</b>	
<i>Labor:</i>	
1 foreman	\$ 4.00
1 engineer	5.00
1 fireman	2.50
1 signalman	2.50
2 dumpers, @ \$2.00 each	4.00
30 laborers, @ \$2.00 each	60.00
Total labor expense, per day	\$78.00
<i>Fuel and Supplies:</i>	
½ ton coal, @ \$5.00	\$2.50
Oil, waste, etc.	1.00
Repairs	1.50
Total Fuel and Supplies	\$5.00
<i>General and Overhead Expenses:</i>	
Interest (6% of \$8000)*	\$2.40
Depreciation (10% of \$8000)*	4.00
Incidental expenses	2.60
Total general expense	\$9.00
Total Cost of Operation for a 10-hour Day	\$92.00
Total Output for a 10-hour Day (cu. yd.)	300
Unit Cost of Tower Cableway Excavating, per cu. yd. of material handled, \$92.00 ÷ 300 =	00.30
Unit Cost of Hoisting, Conveying, and Dumping (excluding pick and shovel labor), per cu. yd. of material handled, \$29.00 ÷ 300 =	00.097

\*Based upon 200 working days in a year and a 10-year life.

**Field of Usefulness.** The cableway excavator has a wide and important field of usefulness. It is especially efficient in the handling of materials across large waterways, valleys, quarries, pits, etc., where surface transportation would be difficult and very expensive. In the excavation of large quarries, gravel pits, surface mines, dam foundations, reservoirs, etc., the cableway can be used as a tower excavator directly or to convey skips, tubs, or buckets which contain the material previously excavated by other machines. The same cableway can of course be used for the transportation of concrete, stone, timber, and other building materials, as well as tools, men, etc., during the construction work which follows the excavation.

The cableway can be satisfactorily used in trench excavation when the excavation is of large extent; generally over 6 feet in width and 10 feet in depth. With the use of this type of excavator, the weight of the machinery is largely concentrated at the ends of the trench, the cable is at a considerable height above the work and allows space for storage, handling of materials, etc. The principal objection to the use of the cableway on trench work is its lack of lateral control. It is almost impossible to avoid the swinging of the buckets during the raising and lowering, and this is liable to result in some displacement of and damage to the sheeting, forms, etc.

#### TILE-TRENCH TYPES

**General Features.** Preceding the year 1900, trench excavation for drain tile was made largely by hand. With the rapid and extensive development of agricultural drainage through the South and Middle West, came the use of machinery to economically and expeditiously perform the great amount of excavation work required by the construction of drainage systems. At the present time, there are several makes of trench excavators, which are especially adapted to tile-trench excavation.

The essential parts of tile-trench excavators are practically the same as for the water and sewer-pipe trench machines, described under Pipe-Trench Types. There is one make of machine which has been specially devised for the laying of the tile as well as for the excavation of the trench. A description of this machine will follow.

## HOVLAND TILE DITCHER

**Power Equipment.** The Hovland tile ditcher is made in two sections: a front platform which carries the power equipment, and a rear platform which carries the excavating chain. Both platforms are made of a steel framework supported on two large caterpillar tractors. Fig. 73 shows a general view of the Hovland tile ditcher.

It will be noticed that the forward tractor carries the power equipment which consists of a vertical, 3-cylinder gasoline engine. The main shaft of the engine is connected by sprocket chains to the driving shafts of the excavating belt of the tractions, and of the belt conveyor.

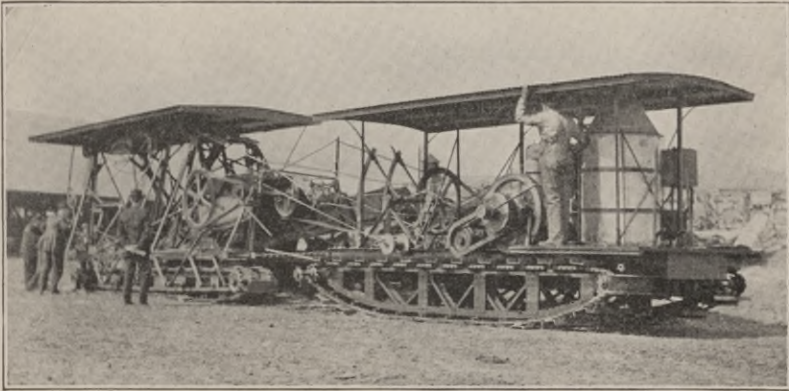

Fig. 73. View of Hovland Tile Ditcher

*Courtesy of St. Paul Machinery Manufacturing Company, St. Paul, Minnesota*

**Excavating Equipment.** The excavating equipment is carried on the rear platform and consists of an excavating chain and its supporting framework.

The excavating chain is made up of two continuous chains which carry an endless set of hinged links. To the vertical sections of these links are bolted the knives or cutters of any width from 5 inches to 30 inches. The links are hinged in such a way that when a cutter strikes a stone or other obstruction in a trench, the chain gives, and the cutter slides over the obstruction without injury. An automatic cleaning device consisting of a projecting arm, is placed above the upper end of the chain and scrapes over



the surface of each bucket as it passes. The excavated material is thus removed from the buckets and falls upon a moving belt conveyor which is located under the excavating chain at its upper end.

The framework which supports the excavating chain is shown in Fig. 74. It comprises a small, upper wheel and a large, lower wheel, or drum, about which the chain revolves. The lower wheel is suspended by chains from the rear of the frame and can be raised and lowered by a gear-operated shaft. The upper wheel is on a shaft which is chain-driven from the engine located on the forward platform.

An adjustable steel-frame curbing can be fastened to the rear of the excavating tractor and drawn along the completed trench.

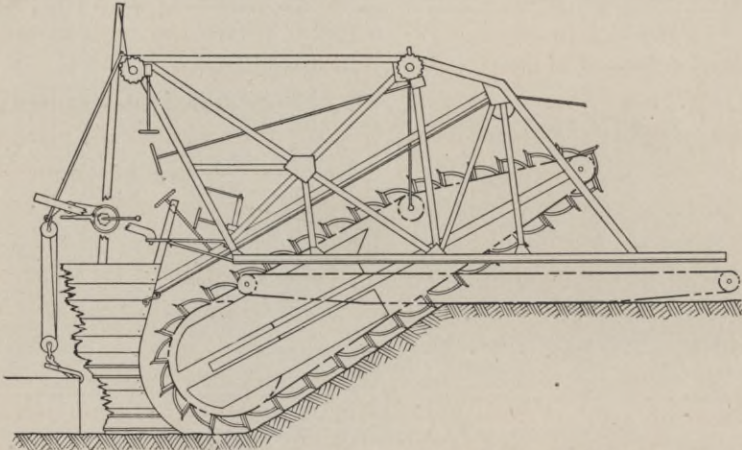

Fig. 74. Excavating Wheel and Frame of Hovland Tile Ditcher  
 Courtesy of St. Paul Machinery Manufacturing Company, St. Paul, Minnesota

This curbing can be adjusted to the width of the trench and made high enough to project above the ground surface. A steel spout is placed on the inner and curved portion and as the machine progresses, a man places a tile in at the top of the spout, which is curved so as to allow the tile to slide out in place along the bottom of the finished trench.

**Method of Operation.** A crew of 3 or more men are necessary to properly operate a tile-trench excavator: an engineer who has charge of the operating equipment, an operator who manipulates the excavating wheel, a tile layer and one or more laborers to supply

fuel, water, and supplies for the machine and for general service about the work.

The revolution of the excavating chain or wheel brings a series of knives or buckets into contact with the soil and each bucket removes a slice of earth, which is dumped upon the belt conveyor and carried to the spoil bank, at the sides of the trench. The operator lowers the wheel or chain into the soil as the excavation proceeds and governs the depth by a sight rod, placed on the machine. As soon as the required depth is reached the engineer sets the tractor chain in motion and the machine moves ahead to the next position.

With the Hovland tile ditcher the drain tile can be laid as the excavation is completed, by placing the tile in the curb which follows directly behind the excavating chain, Fig. 74. It is often necessary to reset the tile after it leaves the curb in order to secure proper alinement and close-fitting joints.

One manufacturer has devised a longitudinal belt conveyor, which carries the excavated material to a point behind the machine and dumps it back into the trench. This device has not been satisfactory because it does not allow enough time after the excavation for the placing of the tile.

**Cost of Operation.** An approximate estimate of the capacity and cost of operation of a tile ditcher will be given in the following statement.

*Illustrative Example.* A trench machine has a gasoline power equipment and an excavating chain or wheel capable of digging a trench  $14\frac{1}{2}$  inches wide and  $4\frac{1}{2}$  feet deep. The soil is loam and clay with gumbo in places. The average depth of cut is  $4\frac{1}{2}$  feet, and the average progress is 1300 feet per 10-hour day.

<b>Operating Cost of Tile Ditcher</b>		
<i>Labor:</i>		
1 operator, @ \$125 per month	\$5.00	
1 fireman	2.00	
1 helper	2.00	
1 team and driver	5.00	
	<hr/>	
Total labor cost, per day		\$14.00
<i>Fuel and Supplies:</i>		
10 gallons gasoline, @ 20c	\$2.00	
Oil, waste, etc.	.50	
	<hr/>	
Total fuel and supply cost		\$2.50

*General and Overhead Expenses:*

Interest (6% of \$5200)*	\$2.00	
Depreciation (12½% of \$5200)*	4.25	
Repairs and incidentals	2.75	
Total general expense		\$9.00
Total Operating Cost per 10-hour Day		\$25.50
Average Progress per Day (ft.)	1300	
Average Daily Excavation (cu. yd.)	260	
Unit Cost of Tile-Trench Excavating	{ per ft. \$25.50 ÷ 1300 { per cu. yd. \$25.50 ÷ 260	00.019 00.098

**Field of Usefulness.** The tile-trench excavator is a very efficient and practicable machine for ordinary soil conditions in fairly level land with few obstructions. Where the soil is low and wet, the machine must be supported on caterpillar tractors to distribute the weight over the soft soil. Where obstructions such as large stones, roots, etc., abound, a large amount of extra hand labor is required.

For work of considerable magnitude, the tile ditcher can excavate a trench at about  $\frac{1}{2}$  the cost of hand labor.

\* Based on 150 days per year and an 8-year life.



## REVIEW QUESTIONS



# REVIEW QUESTIONS

ON THE SUBJECT OF

## RAILROAD ENGINEERING

### PART I

---

1. What are the elements of railroad location which are in general antagonistic? Deduce from the above the chief duties of the locating engineer.

2. What is the chief object to be accomplished by a reconnoissance survey?

3. What are the three elements involved in the survey of any line and what are the methods of determining these elements in reconnoissance surveys?

4. What is the practical value and what are the limitations of barometric leveling?

5. What is the general object to be accomplished by means of a preliminary survey?

6. To what extent should the compass needle be used during preliminary surveys?

7. Why is it that a Locke level with its limited accuracy is a proper instrument for cross-section work?

8. Under what circumstances is the stadia method advantageous for preliminary surveys?

9. What is the justification of making two or more preliminary surveys through difficult portions of the route?

10. How are the tangents and curves for the "location" determined? How is the location survey "tied" to the preliminary survey?

11. How would you select a low-grade line through a difficult piece of mountainous country?

12. How are transit stations and bench marks secured against disturbance during construction of the road?

## RAILROAD ENGINEERING

13. Define the degree of a curve. What is the approximate rule for the radius of a curve of a given degree? What is the percentage of error of this rule for a  $10^\circ$  curve?

14. What is a sub-chord? What will be the excess length of a sub-chord with a nominal length of 45' on a  $5^\circ$  curve?

15. What is the difference between the nominal length of a railroad curve and its true length measured on the arc? What will this amount to in the case of a  $6^\circ$  curve subtending a central angle of  $34^\circ 30'$ ?

16. If two adjacent tangents which make an angle of  $24^\circ 16'$  are connected by a  $3^\circ 30'$  curve, what will be the distance from the vertex to the point of the curve?

17. In the case given above, how far will the curve pass from the vertex?

18. A  $3^\circ 30'$  curve is to begin at Sta. 142+65 and is to have a total central angle of  $28^\circ 30'$ ; compute the deflections from the tangent at the P.C. to each station and to the P.T.

19. In the above case assume that on account of obstructions to sighting it was necessary to set up the instrument at Sta. 147 and sight back to Sta. 144. Applying the rule of section 25, what should be the reading of the horizontal plate when the instrument is sighted at Sta. 144, and what should be the reading when it is sighted ahead at Sta. 148?

20. Assume that a  $3^\circ$  curve having a central angle of  $14^\circ 30'$  is to be located by tangential offsets; make a sketch of this case and compute and mark on the sketch the deflections and distances.

21. After running a  $4^\circ$  curve to some point  $n$  as in Figure 16, the curve is found to be obstructed. It is estimated that the curve would again be clear about 400 feet farther on. Compute the long chord  $nm$  and the angle which  $nm$  would make with a tangent to the curve at  $n$ . What would be the offset from this long chord to the second station beyond  $n$ ?

22. Give detailed solutions of the problems stated in section 30?

23. Give detailed solutions of the problems stated in section 34?

24. What is the essential character of a transition curve and why is it necessary?

# REVIEW QUESTIONS

ON THE SUBJECT OF

## RAILROAD ENGINEERING

### PART II

---

1. What is the chief cause of the deterioration of locomotive boilers due to impure water supply?
2. What are the chief difficulties encountered in the construction of engine houses and how are the difficulties met?
3. What elements must be considered in computing the total cost of any kind of railroad tie?
4. What is the preferable method of locating ties with reference to rail joints?
5. Assuming that an 85-pound rail and a 70-pound rail have similar cross-sections, what is the relative stiffness?
6. What are the elements of a perfect rail joint and why is it impossible to produce a perfect rail joint for steam railroad work?
7. Why are plain smooth spikes preferable to spikes which are jagged?
8. What are the three principles which form the basis of the design of nut locks?
9. Give a brief statement of the general methods of obtaining a pure water supply.
10. What are the elements of an ideal form of ballast? What are the disadvantages of "mud" ballast? What are the advantages of stone ballast?
11. What are the causes, other than mere decay of the wood, which require that ties should be renewed?
12. What are the features of the A. S. C. E. rail section which are constant for all weights of rails and what are the proportions which are constant or nearly constant?
13. What are the advantages and disadvantages in using very long rails?



## RAILROAD ENGINEERING

14. What are the advantages obtained by the use of tie plates?

15. How many track bolts in a mile of single track using six-bolt splice bars and 30-foot rails?

16. How much is allowed for rail expansion and how is this practically provided for?

17. How much gap would you allow at a rail joint when the temperature of the rail at the time of laying is  $45^{\circ}$  F?

18. What should be the middle ordinate of a 30-foot rail bent to a  $40^{\circ}$  curve?

19. What would be the superelevation of the outer rail for a  $60^{\circ}$  curve when the maximum speed is 45 miles per hour?

20. If the maximum speed for trains is assumed at 60 miles per hour, what will be the length of a string or tape which, when stretched as a chord inside the rail, will give a middle ordinate equal to the required superelevation?

21. What is the fundamental advantage of a point switch over a stub switch?

22. Suppose it were required to make to order a frog having a frog angle of  $6^{\circ} 30'$ ; what would be the frog number?

23. Verify the calculations for the length of the lead of a switch from a straight track using a No. 8 frog on the basis, first, of circular lead rails, and second, of straight point rails and straight frog rails, using the values given in Table III.

24. If a No. 8 frog has been used in switching from a straight track, what will be the radius of the connecting curve when the distance between track centers is 13 ft.?

25. What will be the length and radius of the connecting curve running from a switch on the outside of a main track, which is a  $4^{\circ} 30'$  curve, the frog used being No. 9 and the distance between the track centers 13 ft.?

26. Make all the computations for the location of a turnout to the inside of a  $4^{\circ}$  curve using a No. 8 frog.

27. What are the different kinds of tracks making up a freight yard?

28. By what device is engine service economized in planning a freight yard?

# REVIEW QUESTIONS

ON THE SUBJECT OF

## RAILROAD ENGINEERING

### PART III

---

1. Discuss the two classes of financial interests in the ownership of railroads—the security and profits of each.

2. Describe methods of estimating the probable volume of traffic on a proposed road.

3. Discuss the division of the gross revenue and the percentages spent in operating expenses, fixed charges, and dividends.

4. Discuss operating expenses per train-mile; their uniformity for heavy and light traffic roads; the tendency toward variation of the chief items.

5. Discuss the relation of railroad rates to railroad expenses.

6. Explain why a reduction in distance is profitable when handling competitive business, but unprofitable when handling non-competitive business.

7. Discuss curve compensation; the reasons for its use; the values which should be employed.

8. Explain the distinction between minor and ruling grades.

9. What is the meaning of “velocity head”? What is the velocity head of a train when moving at the following velocities in miles per hour: 21; 27.4; 32.25? What velocities correspond to velocity heads of 18.58; 38.92; 49.25?

10. Explain the fundamental principle of a virtual profile, and describe its use and possible misuse.

11. Classify train resistances, with a brief discussion of each class or kind.

12. How much additional tractive force per ton will be necessary to increase the velocity of a train from 8 m.p.h. to 22 m.p.h. in a distance of 800 feet?

## RAILROAD ENGINEERING

13. Assume that an engine weighs 253,000 pounds and that its cylinder tractive power at  $M$  velocity is 33,778 pounds, what is its rating for a 1.1 per cent grade?

14. How many cars (empties) each weighing 17 tons, could be hauled up that grade?

15. On the basis of a Mikado locomotive, with 220,000 pounds on the drivers, weighing 435,000 pounds, including tender, total heating surface 4720 square feet, besides a superheater, boiler pressure 170 pounds, using 4000 pounds of coal per hour, whose effective B.t.u. is 11,500, cylinders 28 inches in diameter and 32 inches stroke, drivers 63 inches diameter:

(a) What is the maximum velocity ( $M$ ) at which full pressure of steam may be maintained?

(b) What will be the cylinder tractive power and the draw-bar pull at  $M$  velocity?

(c) What will be the cylinder tractive power at a velocity of 20 m.p.h.?

(d) Draw the curves for cylinder tractive power and draw-bar pull for all velocities up to 35 miles per hour.

(e) Assuming a train of 20 freight cars averaging 68 tons and a caboose weighing 12 tons, what is the maximum rate of speed which could be maintained on a 0.7 per cent grade?

(f) Draw the speed curve for acceleration from starting to maximum speed for this train and grade.

16. Demonstrate the fundamental principle in the economy of pusher grades.

17. Given a maximum grade of 2.10 per cent, what would be the corresponding through grade if *one* pusher engine is used—the engine being of the type described in Question 15? If *two* pushers were used on the 2.10 per cent grade, what would be the corresponding one-pusher and through grades?

18. Discuss the elements of the cost of the operation of pusher engines.

19. Discuss the fundamental principles of the "balance of grades for unequal traffic".

20. Assume that an investigation showed a 3:1 ratio in east-bound and west-bound traffic. On the basis of a 0.7 per cent grade against east-bound traffic and the use for both through and pusher work of engines of the type described in Question 15, what would be the corresponding grade against west-bound traffic?

# REVIEW QUESTIONS

ON THE SUBJECT OF

## EARTHWORK

### PART I

---

1. State the different classes of power shovels.
2. How would you excavate a canal 200 feet wide and 15 feet deep?
3. Compute the time and cost of excavation with a  $\frac{3}{4}$ -yard revolving shovel of a basement excavation, 200 feet long, 60 feet wide, and 10 feet deep, in a sandy clay soil.
4. How many cubic yards of loam and clay can one laborer loosen from a pit 5 feet deep and shovel into  $1\frac{1}{2}$ -yard dump wagons in a 9-hour day?
5. Compute the cost of operation of a 2-yard drag-line excavator on an irrigation canal in glacial clay and requiring the removal of about 2500 cubic yards per 100 feet.
6. What is the most efficient method of supporting an excavator on soft wet soils?
7. Describe the method of operation of an elevating grader.
8. Give an analytical statement showing the relative economy of hand- and power-shovel excavation.
9. Discuss the factors which determine the method to be used in excavation.
10. Discuss the relative efficiencies of four types of scrapers.
11. State the advantages of electric operation of a power shovel.
12. What is the drag-line principle?
13. Describe a machine which can excavate a canal to a true grade and with smooth side slopes.
14. Describe and illustrate by a diagram the operation of a double-tower excavator.

## EARTHWORK

15. Describe the different tools and methods of loosening earth.
16. Describe the method of grading up an earth road with a blade grader.
17. What are the relative advantages of blade and elevating graders in earth-road construction?
18. Describe the method of operation of a steam shovel of the fixed-platform type.
19. Describe the most economical power equipment to use on a drag-line excavator operating on a canal in the Middle West, twenty miles from a railroad.
20. What are the special fields of usefulness of the small revolving shovels?
21. Describe the various types of hand shovels.
22. What type of dredge would you use on a job where there were several canals to be dug in the same locality?
23. Describe the machine which can be most economically used for the excavation of small ditches in favorable soils.
24. Describe the walking equipment of a walking drag-line excavator.
25. Discuss the relative efficiency of different types of excavators in shallow earth excavation.

# REVIEW QUESTIONS

ON THE SUBJECT OF

## EARTHWORK

### PART II

---

1. What are the principal fields of usefulness of a hydraulic dredge?
2. Compute the cost per foot of trench excavation and tile laying for 12-inch tile at a depth of 5 feet.
3. Can a hydraulic dredge excavate hard materials?
4. What are the different classes of dipper dredges?
5. Describe a ditcher which can excavate a trench and lay tile.
6. Describe the operation of a Lobnitz rock cutter.
7. Describe the most efficient operating equipment of a dipper dredge.
8. Why has the ladder dredge not become a more generally used excavator in this country?
9. Discuss the relative merits of three different makes of continuous bucket excavators.
10. What are the fields of usefulness of the tower cableway?
11. Describe the method of operation of a ladder dredge.
12. What kind of side spuds are the most satisfactory for dredge operation in narrow canals?
13. Describe the continuous bucket excavator.
14. How are high banks excavated with a ladder dredge?
15. Illustrate and describe the section of a ditch which a dipper dredge can excavate.
16. What is the best form of excavator to use in the excavation of large trenches in narrow city streets? Why?
17. Describe three types of buckets.
18. Describe the operating equipment of a hydraulic dredge.

## EARTHWORK

19. What method of subaqueous rock excavation is used in this country?
20. When should electric operation be used on a hydraulic dredge?
21. How would you operate traveling derricks on trench excavation?
22. Describe the method of operation of the trestle track excavator.
23. Compare the relative efficiency and scope of work of the Lobnitz rock cutter and the drill boat.
24. State the different classes of trench excavators.
25. Discuss the field of usefulness of the dipper dredge.

# INDEX





# INDEX

*The page numbers of this volume will be found at the bottom of the pages;  
the numbers at the top refer only to the section.*

	Page		Page
<p>Abutments</p> <p style="margin-left: 100px;">Ballast</p> <p style="margin-left: 100px;">  amount</p> <p style="margin-left: 100px;">  broken stone</p> <p style="margin-left: 100px;">  cinders</p> <p style="margin-left: 100px;">  cost</p> <p style="margin-left: 100px;">  gravel</p> <p style="margin-left: 100px;">  laying</p> <p style="margin-left: 100px;">  mud</p> <p style="margin-left: 100px;">  shells, fine coals, etc.</p> <p style="margin-left: 100px;">  slag</p> <p style="margin-left: 100px;">Cattle guards</p> <p style="margin-left: 100px;">Cattle passes</p> <p style="margin-left: 100px;">Coaling stations</p> <p style="margin-left: 100px;">Compound curves</p> <p style="margin-left: 120px;">  definition</p> <p style="margin-left: 120px;">  location, modifications of</p> <p style="margin-left: 120px;">  two branches, mutual relations of</p> <p style="margin-left: 100px;">Construction, earthwork</p> <p style="margin-left: 100px;">Constructive earthwork</p> <p style="margin-left: 100px;">Continuous bucket excavator</p> <p style="margin-left: 100px;">Corbels</p> <p style="margin-left: 100px;">Crossings</p> <p style="margin-left: 100px;">Culverts</p> <p style="margin-left: 120px;">  cattle passes</p> <p style="margin-left: 120px;">  old-rail</p> <p style="margin-left: 120px;">  pipe</p> <p style="margin-left: 100px;">Curvature</p> <p style="margin-left: 120px;">  compensation</p> <p style="margin-left: 120px;">  limitations</p> <p style="margin-left: 120px;">  operating disadvantages</p> <p style="margin-left: 100px;">Curves</p> <p style="margin-left: 120px;">  compound</p>	<p>A</p> <p>103</p> <p>B.</p> <p>124</p> <p>126</p> <p>125</p> <p>125</p> <p>126</p> <p>125</p> <p>126</p> <p>124</p> <p>125</p> <p>125</p> <p>C</p> <p>121</p> <p>112</p> <p>120</p> <p>39</p> <p>39</p> <p>41</p> <p>40</p> <p>59</p> <p>83</p> <p>418</p> <p>104</p> <p>170, 171</p> <p>110</p> <p>112</p> <p>112</p> <p>110</p> <p>235</p> <p>236</p> <p>239</p> <p>235</p> <p>39</p>	<p>Curves (continued)</p> <p style="margin-left: 20px;">simple</p> <p style="margin-left: 20px;">transition</p> <p style="margin-left: 20px;">vertical</p> <p style="margin-left: 100px;">D</p> <p style="margin-left: 20px;">Dipper dredge</p> <p style="margin-left: 20px;">Distance</p> <p style="margin-left: 40px;">  effect on receipts</p> <p style="margin-left: 40px;">  relation to rates and expenses</p> <p style="margin-left: 20px;">Ditches</p> <p style="margin-left: 20px;">Dredges</p> <p style="margin-left: 40px;">  excavators, dry-land</p> <p style="margin-left: 40px;">  excavators, floating</p> <p style="margin-left: 40px;">  rock breakers, subaqueous</p> <p style="margin-left: 20px;">Dry-land excavators</p> <p style="margin-left: 40px;">  drag-line, walking</p> <p style="margin-left: 40px;">  revolving</p> <p style="margin-left: 40px;">  scoop, walking</p> <p style="margin-left: 40px;">  scraper, stationary</p> <p style="margin-left: 40px;">  templet</p> <p style="margin-left: 40px;">  tower</p> <p style="margin-left: 40px;">  wheel</p> <p style="margin-left: 100px;">E</p> <p style="margin-left: 20px;">Earthwork</p> <p style="margin-left: 40px;">  excavations, methods of</p> <p style="margin-left: 40px;">  principle</p> <p style="margin-left: 40px;">  scope</p> <p style="margin-left: 20px;">Earthwork construction</p> <p style="margin-left: 40px;">  details, constructive</p> <p style="margin-left: 40px;">  roadbed, width of</p> <p style="margin-left: 40px;">  slopes and cross-sections</p> <p style="margin-left: 20px;">Earthwork, constructive</p> <p style="margin-left: 40px;">  blasting</p> <p style="margin-left: 40px;">  classification</p> <p style="margin-left: 40px;">  embankments, formation of</p> <p style="margin-left: 40px;">  excavating</p>	<p></p> <p>26</p> <p>43</p> <p>57</p> <p></p> <p>377</p> <p>231</p> <p>232</p> <p>231</p> <p>61</p> <p>344</p> <p>344</p> <p>377</p> <p>408</p> <p>344</p> <p>373</p> <p>348</p> <p>370</p> <p>344</p> <p>358</p> <p>367</p> <p>362</p> <p></p> <p>301</p> <p>301</p> <p>301</p> <p>301</p> <p>59</p> <p>61</p> <p>61</p> <p>59</p> <p>83</p> <p>83</p> <p>87</p> <p>86</p> <p>83</p>

*Note.—For page numbers see foot of pages.*

	Page		Page
Earthwork—surveys	63	Fresno grader	305
problem, nature of	63	Frogs	149
slope stakes, position of	63		
volume, computing the	66	G	
Economics of railroad engineering	213	Grade	241
curvature	235	accelerated motion, laws of	242
distances	231	minor and ruling, distinction be-	
finances, railroad	213	tween	241
grade	241	profile, virtual	245
location	229	use, value, and possible	
resistances	252	misuse of	249
Economic location	229	Graders	310
economic calculations, reliability		elevating	314
and value of	229	four-wheel blade	310
general principles	229	reclamation	311
Electric shovels	339	two-wheel blade	310
advantages	339		
equipment	339	H	
usefulness	340	Hovland tile ditcher	435
Engine houses	120	Hydraulic dredge	402
Engine yards	178	electric power	404
Excavations in earthwork, methods of	301		
dredges	344	I	
excavators, trench	412	Interlocking	195
graders	310		
hand, details of	302	L	
scrapers, drag and wheel	304	Ladder dredge	388
shovels, power	318	Lobnitz rock cutter	408
		Location surveys	24
F		methods	25
Floating excavators	377	route, selecting a	24
dredge, dipper	377	Locomotives	
dredge, hydraulic	402	acceleration, speed curves	280
dredge, ladder	388	drifting	285
Framed trestles	100	oil-burning	262
abutments	103	power calculations	266, 273, 287
form, general	100	rating of	257
foundations	101	relation of type to service and	
multiple-story	101	to track conditions	263
Freight yards	174	retardation, speed curves	284
accessories	177	route, selection of	288
cranes	178	tractive force at higher velocities	272
scales, track	177	tractive power, effect of grade on	278
connection with main tracks	176	tractive power, relation of boiler	
engine yards	178	power to	274
minor	177	types of	261
principles, general	174		

*Note.—For page numbers see foot of pages.*

# INDEX

3

	Page		Page
Nut locks	138	Railroad finances	213
		capitalization	213
		charges, fixed	222
Old-rail culverts	112	equipment, maintenance of	228
		expenses, operating	223
		classification	225
		expenses, transportation	228
Pile driving	98	monopoly	219
Pile trestles	98	revenue, gross	216
Pipe culverts	110	diversion	220
Pipe-trench excavators	414	revenue, net	222
bucket, continuous	418	stocks and bonds	214
cable, trestle	424	ways and structures, maintenance	
cableway, tower	430	of	225
derrick, traveling	414	Railroad surveys	11
track, trestle	427	interests, conflicting	11
Power shovels	317	principles, general	11
classification	317	Reconnaissance surveys	12
cost, operating	337	elements	13
electric	339	existing maps, utilization of	13
steam, revolving	337	grades, low ruling	17
efficiency and economy	341-344	methods	13
fixed-platform	318	problem, essential	12
revolving-platform	332	Resistances	252
Preliminary surveys	19	grades for unequal traffic, bal-	
cross-section method	19	ance of	296
object, general	19	principles	296
party required	22	relative traffic, estimation of	298
re-surveys	23	theoretical balance, computa-	
stadia method	21	tion of	297
Pusher grades	289	grades, pusher	289
economy, general principles of	289	train	252
engines, operation of	291	locomotives, rating of	257-289
length of	292	locomotives, types of	261
pusher-engine service, cost of	293	operation, units of	259
services, balance of grades for	290	tractive power, effect of	
		grade on	278
		Revolving excavator	348
		S	
Rails	130	Scrapers, drag and wheel	304
length	133	drag	304
weight	131	four-wheel	308
Rail braces	136	Fresno	305
Rail joints	133	two-wheel	306
insulated	135		
Railroad engineering	11		
construction and maintenance,			
work of	11		
economics	213		

*Note.*—For page numbers see foot of pages.

	Page		Page
Signaling	179	Switches	146
systems	179	construction	146
automatic	184	frogs	149
controlled manual	183	guard rails	148
details, mechanical	186	switch stands	148
electro-pneumatic		crossings	170-172
semaphores, electric	194	crossovers	162, 163
simple manual	180	curve connections	159, 160
wires and pipes	191	laying, rules for	167
Simple curves	26	slip	168
deflections, computing	31	turnouts	155, 157
deflections, location of points by	30	Switch stands	148
elements	28		
instrumental work	32	T	
length	28	Tables	
location, modifications of	38	Austin trench excavators, sizes	
location, obstacles to	35	and capacities of	421
location, special methods of	33	cut-off and pounds of steam per	
measurement, method of	26	1 h.p.-hour for various	
1° curve, elements of	29	multiples of $M$	269
sub-chords	27	evaporation in locomotive boil-	
Slip switches	168	ers, average	266
Spikes	136	expenses, operating	224
Stationary scraper excavator	344	expenses of railroads in U. S.,	
Steam shovels		operating	226, 227
fixed-platform	318	fixed-platform shovel, working	
arrangement	318	limits of	325
body, car	321	head velocity of trains	244
equipment, excavating	321	motors for shovel capacities,	
equipment, power	321	sizes of	340
operation, cost of	327	operating a train 1 mile, average	
operation, method of	323	cost of	225
revolving-platform	332	resistance, locomotive	270
arrangement	332	standard steam shovel, sizes of	320
equipment, excavating	334	steam shovel service	328
equipment, power	333	steam used locomotive cylinders,	
operation, method of	335	weight of	268
platforms	332	various grades, values of $C \div (R +$	
Stringers	103	$K)$	258
Subaqueous rock breakers	408	various multiples of $M$ , cylinder	
boat, drill	409	tractive power of	272
Lobnitz	408	wheel excavators, dimensions of	364
Surveys		Templet excavator	358
location	24	Ties	127
preliminary	19	cost	129
railroad	11	cutting	129
reconnaissance	12	dimensions	128

*Note.*—For page numbers see foot of pages.

	Page		Page
Ties (continued)		Trench excavators (continued)	
laying and reviewing	129	pipe-trench	414
spacing	128	tile-trench	434
wood	127	Trestles	97
Tile-trench excavators	434	floor systems	103
ditcher, Hoveland tile	435	framed	100
Tower excavator	430	pile	97
Tower excavator	367	Trestle cable excavator	424
Track and track work materials	124	Trestle floor systems	103
ballast	124	corbels	104
bolts, track	138	fire, protection against	108
braces, rail	136	guard rails	105
joints, rail	133	stringers	103
nut locks	138	super-elevation of outer rail on	
rails	130	curves	106
spikes	136	ties, trestle	106
ties	127	timber, choice of	109
tie plates	135	Tunnel construction	95
Track bolts	138	general principles	95
Track laying	140	methods	96
ballast	140	Tunnel design	92
outer rail on curves, super-eleva-		cross-sections	92
tion of	144	grade	92
practical rules	145	lining	93
rails	141	portals	94
surfacing	144	Tunnels, surveying	88
surveying	140	character of	88
ties	140	distance	89
Track maintenance	197	down shafts	91
ballast	205	levels	89
ditching	202	underground	90
labor, or organization of	209	surface	89
rails, distributing	204	Turnouts	155, 157
ties, distributing	203	Turntables	118
tools	197		
trestle filling	207	V	
work trains	201	Vertical curves	57
Track trestle excavator	427	geometrical form	58
Transition curves	43	use	57
compound curves, use with	53	Volume of earthwork, computing	66
deflections	46	borrow pits	77
field work	56	center of gravity, eccentricity of	79
spirals in old track, inspection of	50	correction, prismoidal	75
symbols	46	curvature, correction for	78
systems	43	irregular ground, volume in	75
Traveling derrick excavator	414	methods, common	66
Trench excavators	412	prismoid, volume of	68

*Note.*—For page numbers see foot of pages.

	Page		Page
Volume of earthwork, computing		Water-supply	115
(continued)		pumping	116
products, computation of	72	tanks	117
sections, equivalent	67	track tanks	117
sections, irregular	73	Wheel excavator	362
sections, level	66		
sections, three-level	69	Y	
side-hill section, eccentricity of		Yards and terminals	173
center of gravity of	82	freight-yard with main tracks,	
side-hill work	77	connection of	176
W		proper design, value of	146
Walking drag-line excavator	373	yards, engine	178
Walking scoop dredges	370	yards, freight	174

*Note.*—For page numbers see foot of pages.





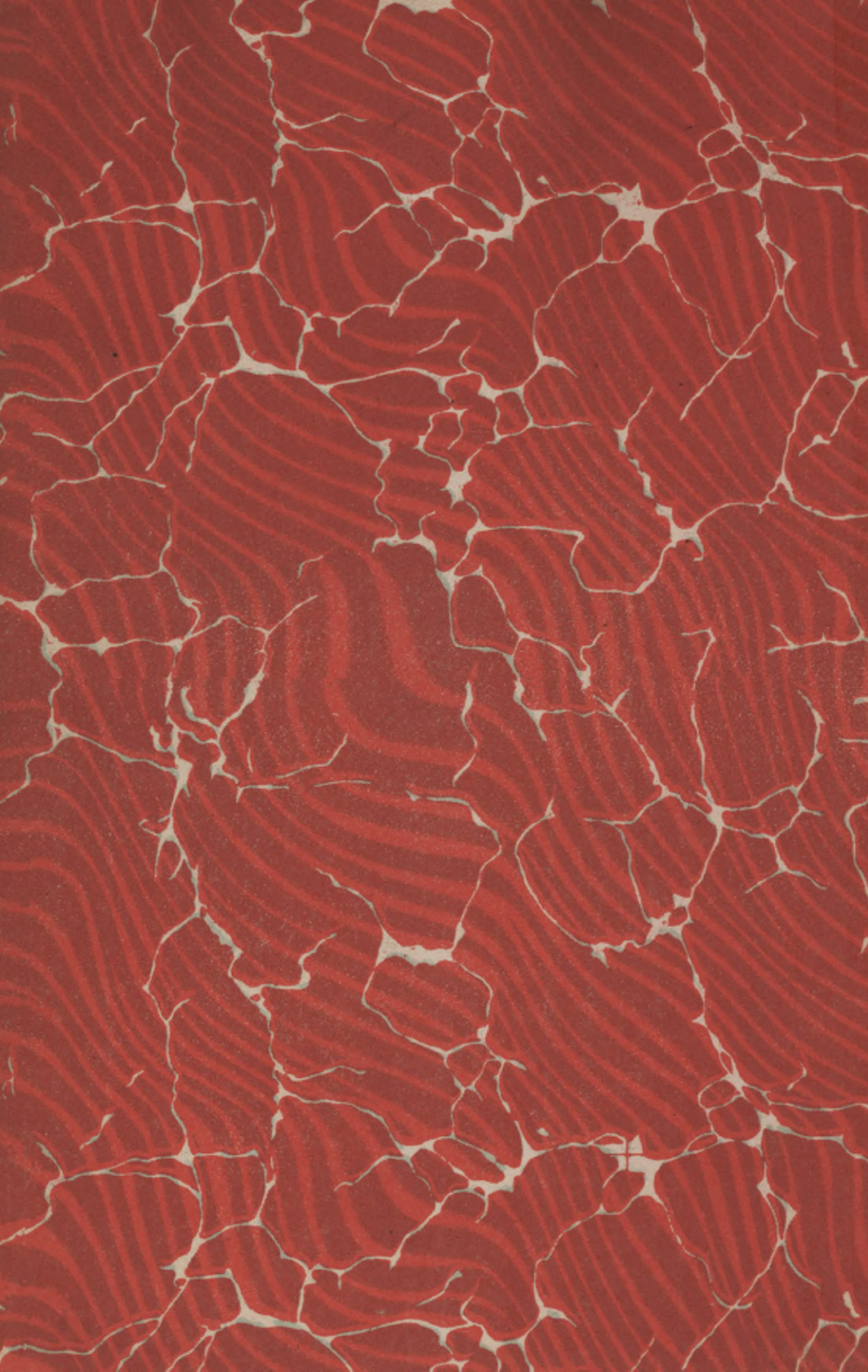

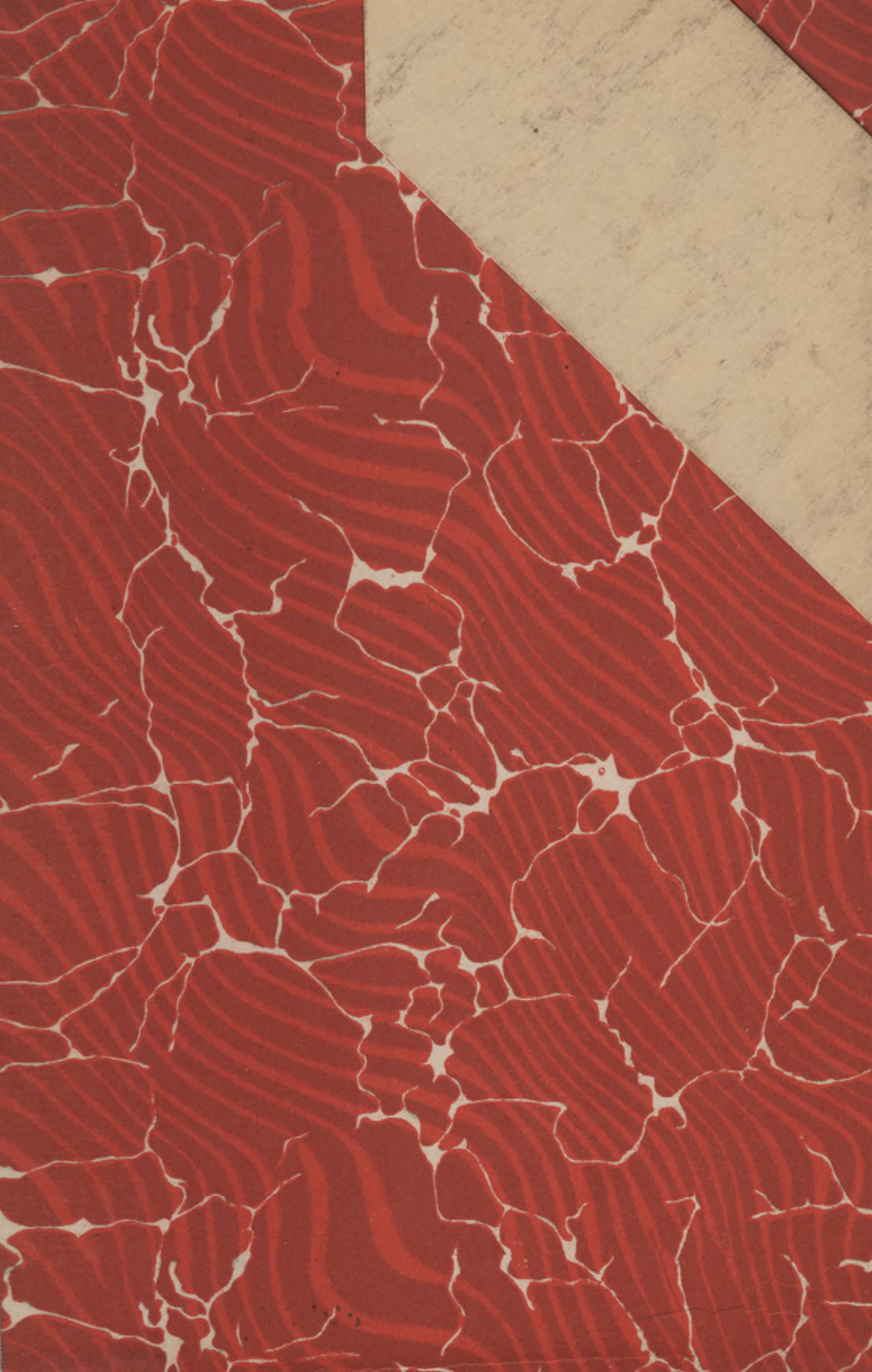

Biblioteka Politechniki Krakowskiej



10000298996